



**INSTALLATION INSTRUCTIONS FOR FLOAT SWITCH KIT (16B29)  
USED WITH ELA SERIES UNITS**

**Shipping and Packing List**

Package 1 of 1 contains:

- 1 – Overflow (float) switch (S149)
- 1 – Relay (K220)
- 2 – Brackets
- 4 – Screws #8-32 x 1/2"
- 1 – Wiring harness
- 3 – Wire nuts
- 15 – Wire ties
- 1 – Wiring diagram

**⚠ WARNING**

Improper installation, adjustment, alteration, service or maintenance can cause property damage, personal injury or loss of life. Installation and service must be performed by a licensed professional HVAC installer or equivalent, service agency, or the gas supplier.

**⚠ CAUTION**

As with any mechanical equipment, contact with sharp sheet metal edges can result in personal injury. Take care while handling this equipment and wear gloves and protective clothing.

**⚠ WARNING**



Electric Shock Hazard! – Disconnect all power supplies before servicing. Replace all parts and panels before operating. Failure to do so can result in death or electrical shock.

**⚠ WARNING**

This product contains a chemical known to the State of California to cause cancer, birth defects, or other reproductive harm.

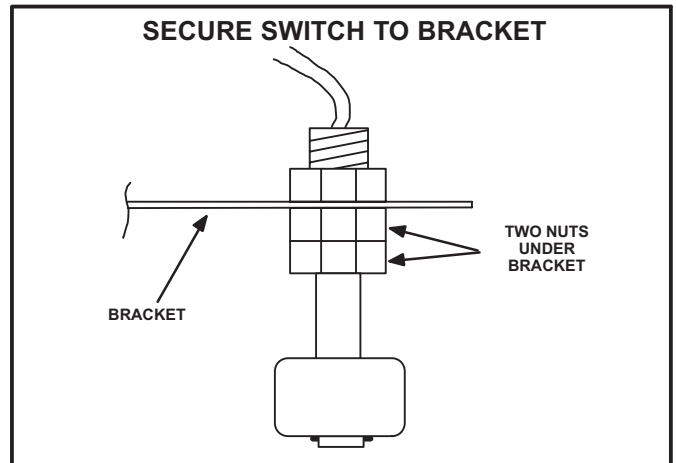
**Application**

The float switch, catalog number 16B29 (part number 602799-07) prevents overflow from occurring after the drain pan has reached capacity. When excessive condensate begins to accumulate in the drain pan, the float switch energizes the K220 relay, causing the contacts to open, which de-energizes the 24V circuit.

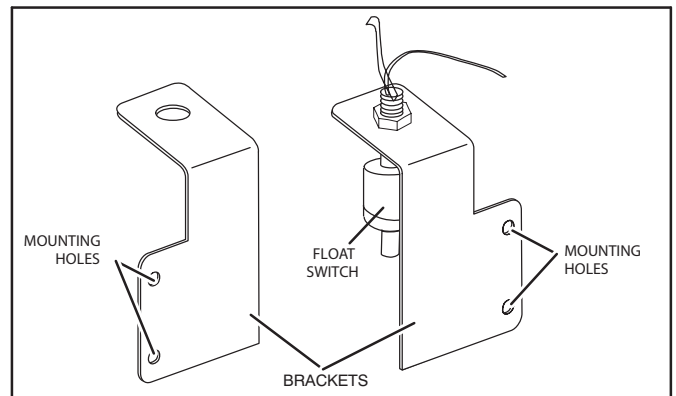
This de-energizes the system by shutting off the compressor and blower circuits. When the water level drops below the set point, the switch opens, de-energizing the relay which closes the circuit. This causes the 24V circuit to re-energize and the system becomes operational again.

**Float Switch Assembly**

- 1 - Disconnect all power to the unit and remove panel to gain access to the control box.
- 2 - Two L-shaped brackets are included in the kit. Use only the bracket with the hole pattern that allows installation as illustrated in figure 3. Secure float switch assembly to proper bracket using the two nuts as illustrated in figures 1 and 2.

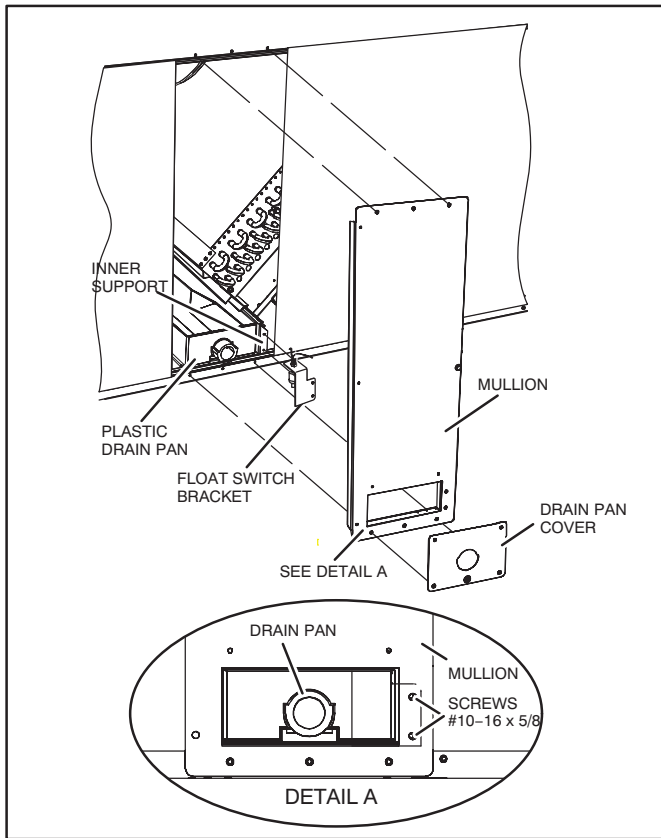


**FIGURE 1. Float Switch Configuration**



**FIGURE 2. Float Switch Mounting**

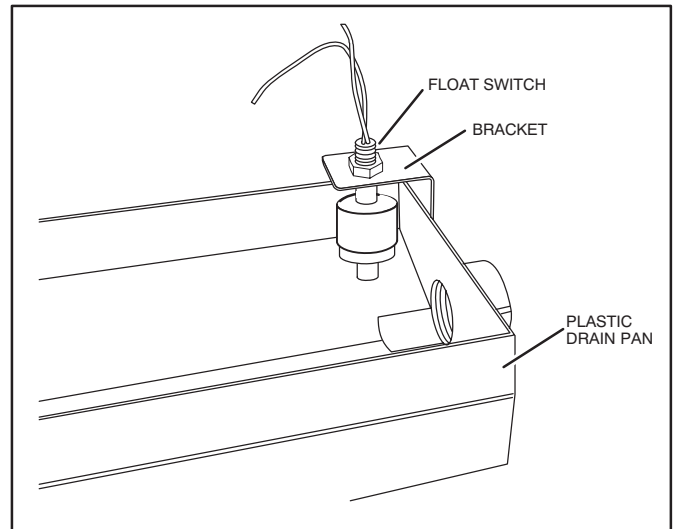




**FIGURE 3. Accessing Mounting Location**

### Hardware Installation

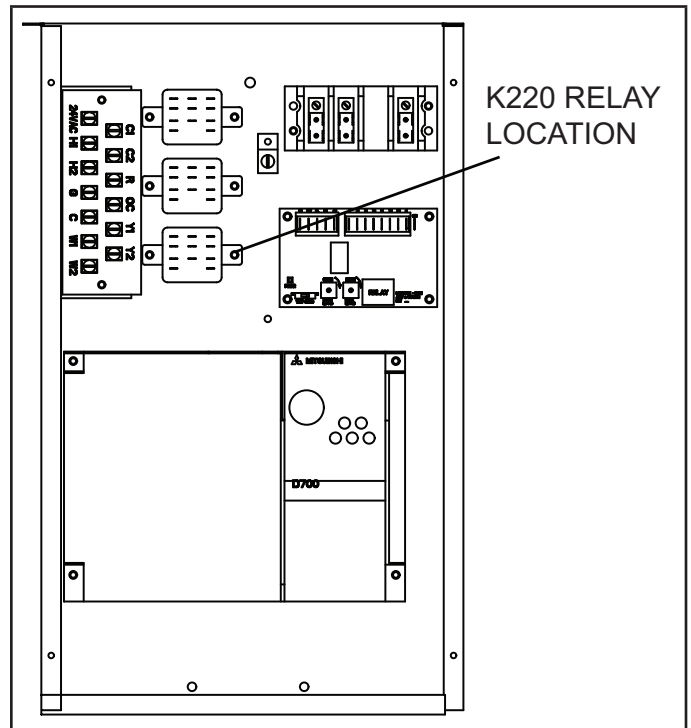
- 1 - Remove the drain pan cover panel at the condensate drain connection as shown in figure 3.
- 2 - Remove the two screws adjacent to the drain pan that fasten the mullion to the inner support as shown in figure 3, detail A.
- 3 - Install the drain pan switch assembly as illustrated in figure 4. The portion of the bracket with the two holes is positioned between the mullion and the inner support. Be certain that the holes in the bracket align with those of the mullion and inner support.
- 4 - Reinstall the two screws removed in step 2.



**FIGURE 4. Float Switch Bracket Installation**

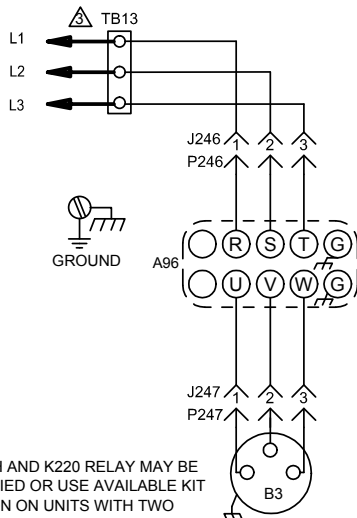
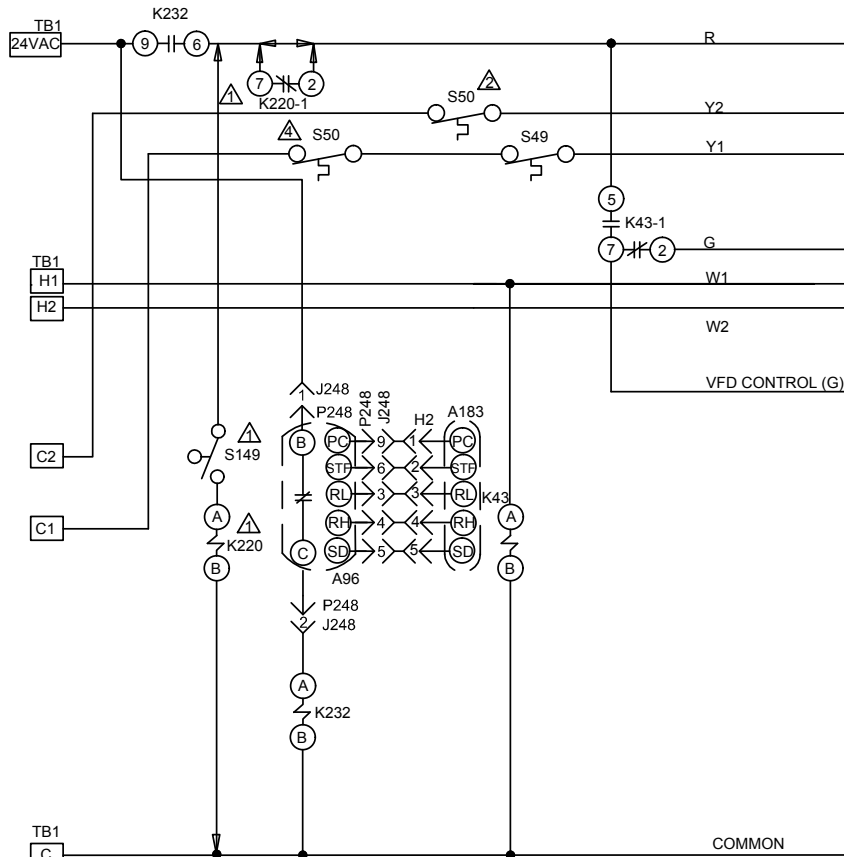
### Electrical Installation

- 1 - Disconnect all power to the unit.
- 2 - Mount the K220 relay provided on the ELA control box using the screws provided.



**FIGURE 5. K220 Relay Location in ELA Control Box**

- 3 - Disconnect the wire from terminal K232-6 and plug it in at terminal K220-2.
- 4 - Use the wire nuts provided to connect one end of the float switch (S149) to the harness terminals K220-A/S149.
- 5 - Connect the other end of the harness terminal marked K220A/ S149 to terminal A on the K220 relay.
- 6 - Connect one end of harness terminal marked TB1-C/ K220-B to terminal B on the K220 relay and the other end to the TB-1 C line.
- 7 - Plug in the harness terminal for K232-6 on terminal 6 of the relay. Plug in one wire from the other end to terminal 7 on the K220 relay and connect the remaining wire to the float switch (S149). See figure 6 wiring diagram for reference.
- 8 - Use wire ties to bundle wiring and keep it away from sharp edges.
- 9 - Reinstall control box and drain pan panels.
- 10 - Restore power to the unit.



KEY	COMPONENT
A96	CONTROL, INVERTER
A183	CONTROL, VFD BOARD
J/P246	JACK/PLUG POWER TO VFD
J/P247	JACK/PLUG VFD TO MTR
J/P248	JACK/PLUG VFD CONTROL
B3	MOTOR-BLOWER
K43-1	RELAY-ECONOMIZER BLOWER
K220-1	RELAY-OVERFLOW
K232-1	RELAY-INVERTER PROTECTION
S49	SWITCH-FREEZESTAT COMPRESSOR 1
S50	SWITCH-FREEZESTAT COMPRESSOR 2
S149	SWITCH-OVERFLOW
TB1	TERMINAL STRIP-CLASS II VOLT
TB13	TERMINAL BLOCK, POWER DISTRIBUTOR

IF ANY WIRE IN THIS APPLIANCE IS REPLACED, IT MUST BE REPLACED WITH WIRE OF LIKE SIZE, RATING, INSULATION THICKNESS AND TERMINATION

WARNING-ELECTRIC SHOCK HAZARD, CAN CAUSE INJURY OR DEATH. UNIT MUST BE GROUNDED IN ACCORDANCE WITH NATIONAL AND LOCAL CODES

DISCONNECT ALL POWER BEFORE SERVICING  
 ← DENOTES OPTIONAL COMPONENTS

- ⚠ S149 SWITCH AND K220 RELAY MAY BE FIELD SUPPLIED OR USE AVAILABLE KIT
- ⚠ S50 LOCATION ON UNITS WITH TWO SINGLE SPEED COMPRESSORS
- ⚠ FOR USE WITH COPPER CONDUCTORS ONLY
- ⚠ S50 LOCATION ON UNITS WITH ONE DUAL SPEED COMPRESSOR

10/17		WIRING DIAGRAM	10/17
		537900-01	
BLOWER			
ELA 072-240 - G,J,Y WITH VFD ID BLOWER			
SECTION B1		REV 0	
Supersedes		New Form No. 537900-01	

© 2012

Lennox Commercial

FIGURE 6. Wiring Diagram