



©2017 Lennox Industries Inc.
Dallas, Texas, USA

COMMERCIAL SPLIT SYSTEM KITS AND ACCESSORIES

507747-01
9/2021
Supersedes 8/2017

AIR FILTER RACK

ASSEMBLY AND INSTALLATION INSTRUCTIONS FOR 4" FILTER RACK USED WITH ELA 072-090, ELA 120-150 AND ELA 180-240 UNITS

Shipping and Packing List

Package 1 of 1 contains:

- 2 – Top / bottom panels
- 2 – Filter channels
- 1 – Front panel
- 1 – Rear panel
- 1 – Door
- 1 – Filter spring
- 1 – Rear panel filler
- 40 – 50-#10 screws
- 1 – Roll gasket material
- 1 – Installation instructions

WARNING

Improper installation, adjustment, alteration, service or maintenance can cause property damage, personal injury or loss of life. Installation and service must be performed by a licensed professional HVAC installer or equivalent, service agency, or the gas supplier.

CAUTION

As with any mechanical equipment, contact with sharp sheet metal edges can result in personal injury. Take care while handling this equipment and wear gloves and protective clothing.

WARNING

This product contains a chemical known to the State of California to cause cancer, birth defects, or other reproductive harm.

WARNING



Electric Shock Hazard! – Disconnect all power supplies before servicing.
Replace all parts and panels before operating.
Failure to do so can result in death or electrical shock.

General

The filter rack is shipped compact, and requires minimal assembly. It is installed on the return air opening on the horizontal flow or upflow unit depending on the application. The cabinet is designed to house 4" MERV 8 or MERV 13 filters, purchased separately.

Required Tools

- Electric drill
- Screwdriver
- Gloves for sharp-edge protection
- Foil tape

Unpacking

The cabinet must be unpacked, separated and assembled prior to use.

- 1 - Remove all protective packing material from the cabinet components.
- 2 - All packing materials should be disposed of properly.
- 3 - Separate all the attached panels before beginning assembly of cabinet.



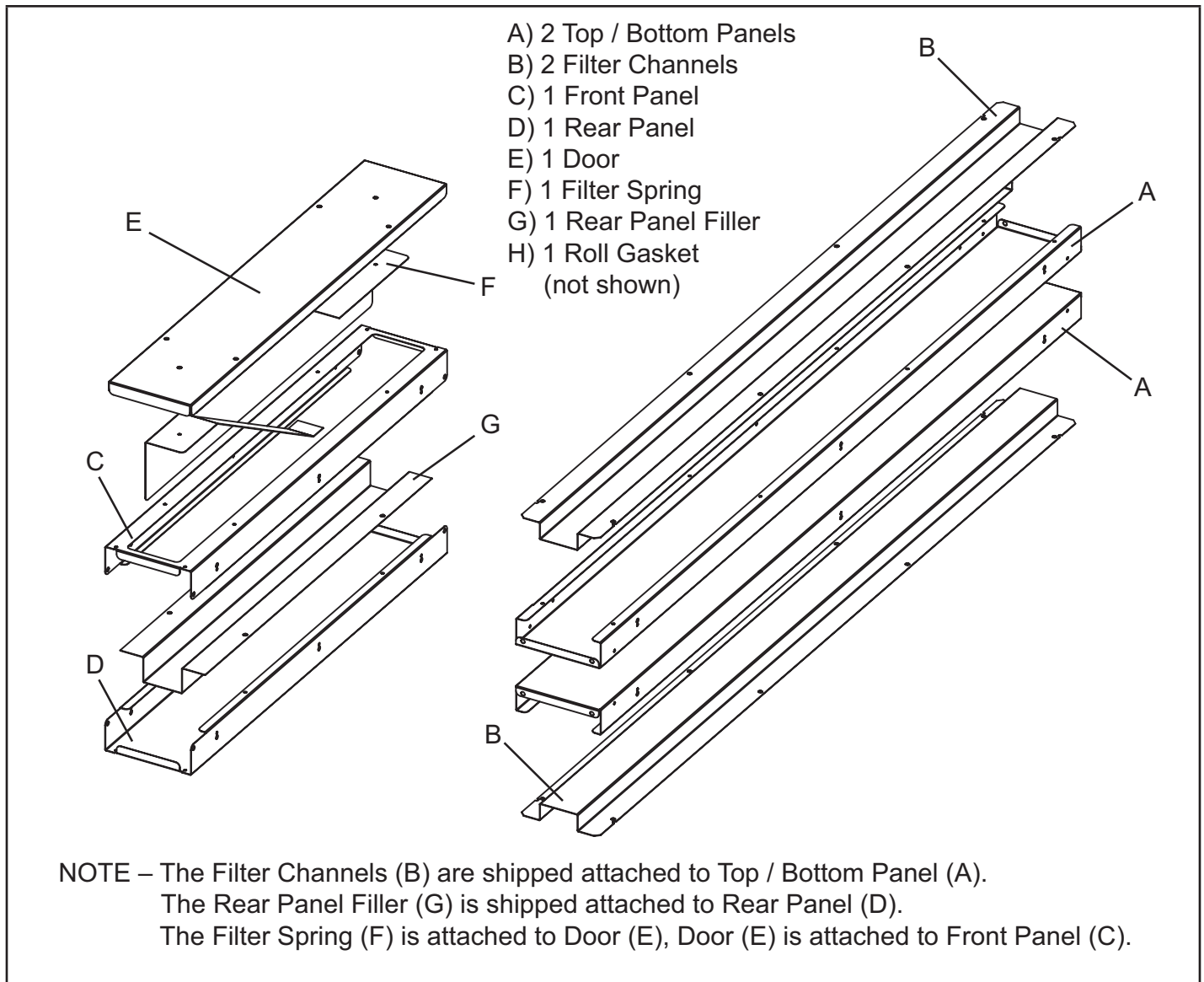

FIGURE 1. Cabinet Components

Filter Cabinet Assembly

The cabinet sections are designed to be attached together. Align the edges as shown in figure 2.

NOTE – The screws provided to attach the filter rack are used only on one side. While mounting filter rack on unit, make sure that the side without screws is flush with the unit.

- 1 - Place one Top / Bottom Panel A on a firm surface. Align front panel C into one end of side panel A (see figure 2). Attach Panel C to Panel A as shown in figure 2 using provided screws.

- 2 - Align and attach rear panel D into Top / Bottom Panel A (see figure 3).
- 3 - Align and attach remaining Top / Bottom Panel A into front panel C and rear panel D. Verify that all screws are tight before attaching filter rack to unit.

NOTE – The Filter Channels and Rear Panel Filler are attached to the cabinet after the cabinet is installed on the unit.

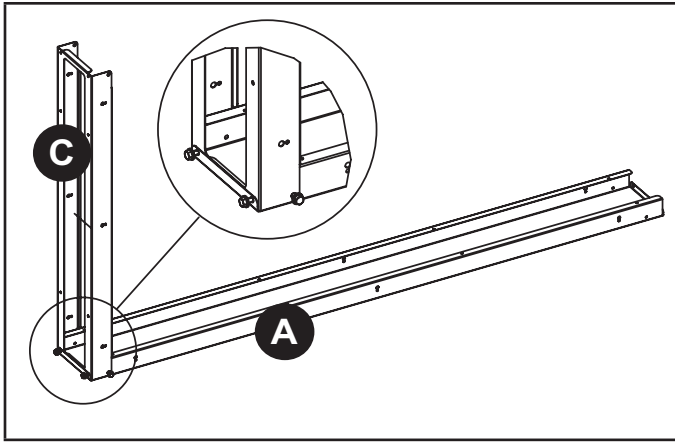

FIGURE 2. Assemble Front Panel (C) to Bottom Panel (A)

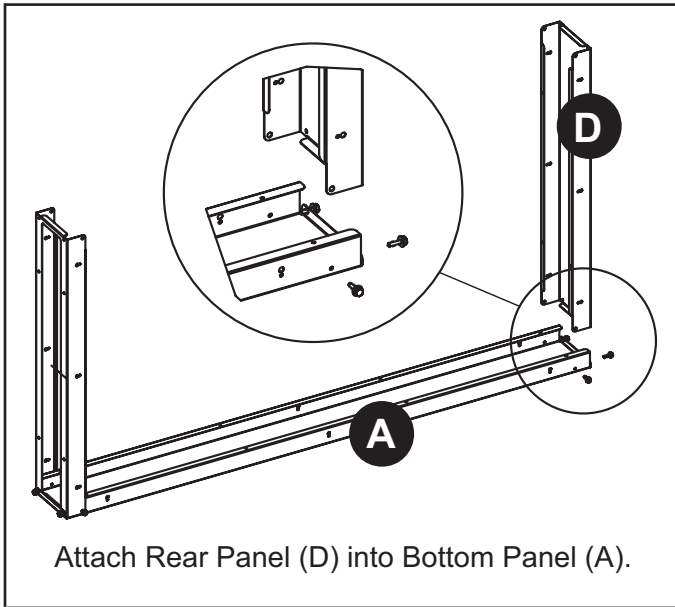
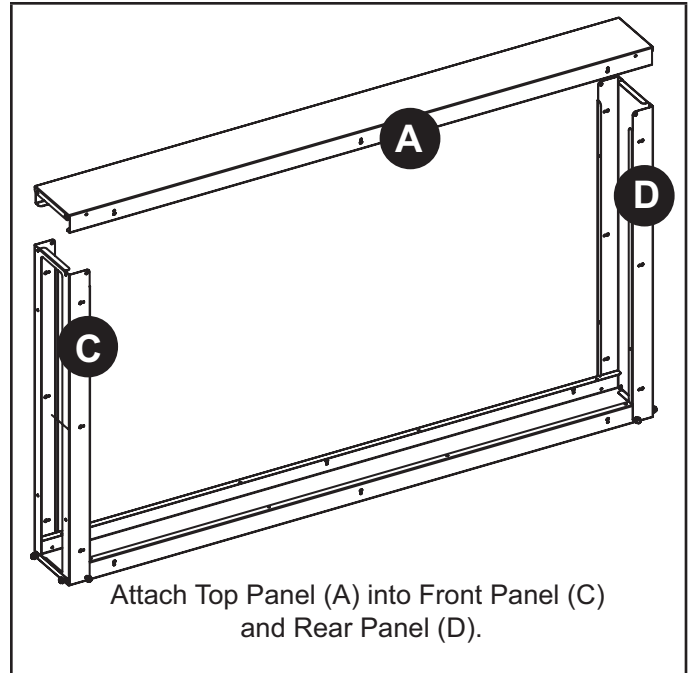

FIGURE 3. Assemble Rear Panel (D) to Bottom Panel (A)



Attach Top Panel (A) into Front Panel (C) and Rear Panel (D).

FIGURE 4. Install Top Panel (A)

Filter Cabinet Installation

- 1 - Turn off the unit completely.
- 2 - Detach the return air duct attached to the 2 inch filter rack. Remove the 2 inch filter rack attached to the return air opening of the indoor unit.
- 3 - Align the 4 inch cabinet with the return air opening on the air handler with the access door opening facing outward.
- 4 - Secure the cabinet to the unit using the screws provided.
- 5 - Insert Filter Channel (B) into the cabinet and use the provided screws to secure them to the cabinet at both the top and bottom. Insert the Rear Panel Filler (G) and attached it to the Rear Panel with the screws provided.
- 6 - Attach the duct to the filter cabinet. Use foil tape to seal all duct joints to prevent dust from entering the air stream.
- 7 - Slide the 4 inch filters (ordered separately) into the filter channel.
- 8 - Attach the filter spring to the cabinet door and secure the door to the front panel.
- 9 - Install provided gasket material on all sides of filter access door and install door.
- 10 - Restart the unit and check for proper operation.