

# INSTALLATION INSTRUCTIONS

## Twinning Kit 16W72

For Single and Two Stage Gas-Fired Furnaces with Constant Torque Blower Motors

This manual must be left with the homeowner for future reference.



This is a safety alert symbol and should never be ignored. When you see this symbol on labels or in manuals, be alert to the potential for personal injury or death.

### ⚠ WARNING

Improper installation, adjustment, service, or maintenance can cause property damage, personal injury, or death. Consult a qualified installer, service agency, or the gas supplier for information or assistance.

### ⚠ WARNING



Risk of electrical shock. Disconnect all remote power supplies before installing or servicing any portion of the system. Failure to disconnect power supplies can result in property damage, personal injury, or death.

### ⚠ CAUTION

Label all wires prior to disconnection when servicing controls. Wiring errors can cause improper and dangerous operation.

### Parts List

Quantity	Part
5	DPST Relay
30	.250 Quick Disconnect Terminal
10	Self-Tapping Screws
1	Installation Instructions

### Application

This accessory kit is used to operate two gas-fired furnaces that are intended to be “twinned together,” meaning connected in a shared duct system controlled by a single thermostat.

- Do not twin more than two furnaces at a time.
- Must be installed and wired in accordance with local codes.
- Used for single-stage heating/single-stage cooling with a single-stage thermostat.
- Used for two-stage heating/single-stage cooling with either a single-stage or two-stage thermostat.



(P) 507827-01

Save these instructions for future reference

## System Operation

With this twinning accessory kit, it is important to understand upon a call for heat from a single thermostat, that both circulation air blowers will come on and go off at the same time. In addition, the induced draft blowers of both furnaces will be energized, the pressure switch of each furnace will close, the gas valve of each furnace will open (either high or low fire depending on furnaces), and the burners of each furnace will ignite. Thirty seconds later, both circulation air blowers will be energized.

When the heat demand is satisfied, the heating relays of each furnace are de-energized and close each furnace's gas valve. Both furnace circulation air blowers will continue to run until the blower off fan period has been met.

- Single-stage furnaces twinned together with a single-stage thermostat will operate each furnace at the same time.
- Two-stage furnaces twinned together with a two-stage thermostat will operate each furnace such that first stage heat of each furnace operates at the same time. When second stage heat demand is needed, both furnaces will transition to high heat at the same time.
- Two-stage furnaces twinned together with a single-stage thermostat will utilize control boards 7.5/10 min. stage transition. Each furnace **must be** set to same setting.

## Installation

To twin two gas-fired furnaces, follow these directions along with the appropriate application section and wiring schematic.

### Single-Stage Heating and Cooling with Single-Stage Thermostat

1. Mount DPST relay(s) (supplied with kit) next to the blower control board of Furnace 1. Use kit supplied self-tapping screws to mount DPST relay(s) to the control bracket.
2. Connect the thermostat with Furnace 1, Furnace 2, and the DPST relay as shown in Figure 1 through Figure 3. Use the female quick connect terminals supplied in kit and the proper length of 18 gauge wire (field supplied) to complete wiring.
3. After wiring is complete, cycle both heating and cooling modes to verify both are working properly.

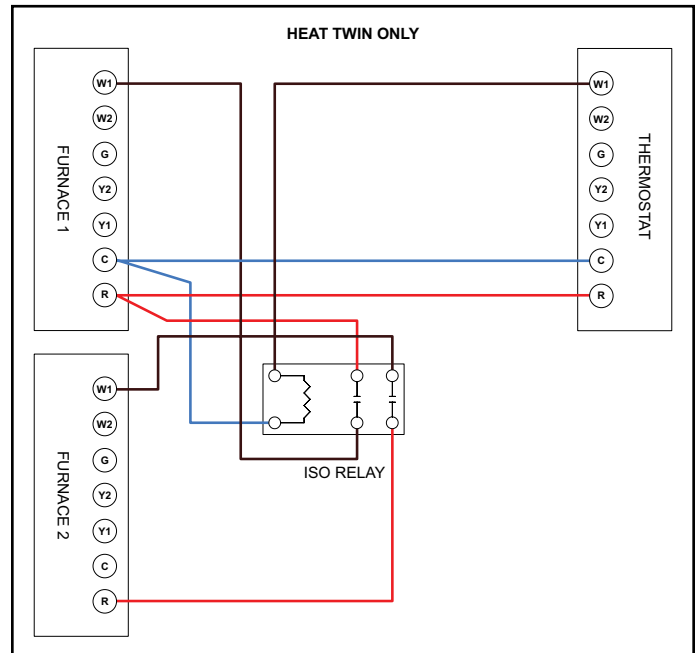

Figure 1.

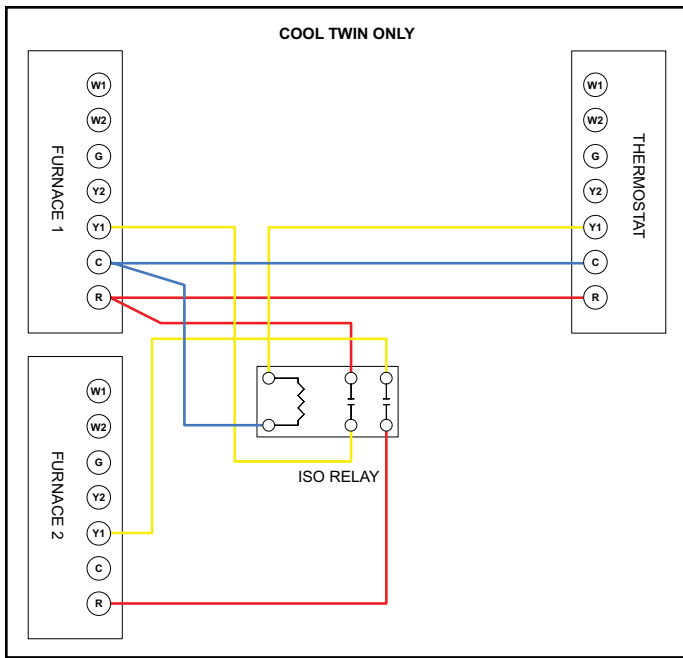

Figure 2.

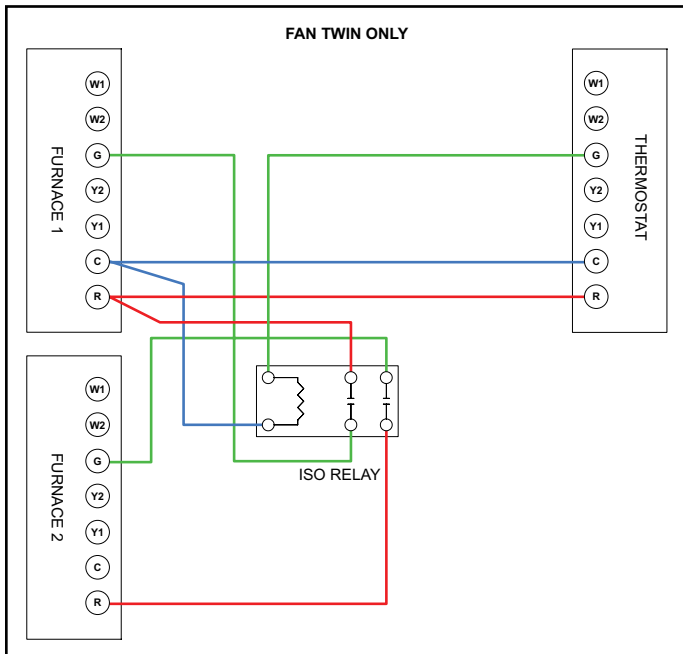

Figure 3.

### Two-Stage Heating and Single-Stage Cooling with Single-Stage Thermostat

1. Mount DPST relay(s) (supplied with kit) next to the blower control board of Furnace 1. Use kit supplied self-tapping screws to mount DPST relay(s) to the control bracket.
2. Connect the thermostat with Furnace 1, Furnace 2, and the DPST relays as shown in Figure 1 through Figure 3. Use the female quick connect terminals supplied in kit and the proper length of 18 gauge wire (field supplied) to complete wiring.
3. Set DIP switches of Furnace 1 and Furnace 2 control boards to same furnace mode DIP switch setting for single stage thermostat, 2nd stage timing setting and blower off setting. See the furnaces' installation instructions for additional detail.  
**NOTE:** Units are factory shipped with DIP switch settings for two-stage thermostat operation.
4. After wiring is complete, cycle both high and low heating modes and cooling modes to verify both are working properly.

**Two-Stage Heating and Single-Stage Cooling with Two-Stage Thermostat**

1. Mount DPST relay(s) (supplied with kit) next to the blower control board of Furnace 1. Use kit supplied self-tapping screws to mount DPST relay(s) to the control bracket.
2. Connect the thermostat with Furnace 1, Furnace 2, and the DPST relays as shown in Figure 4 through Figure 6. Use the female quick connect terminals supplied in kit and the proper length of 18 gauge wire (field supplied) to complete wiring.
3. After wiring is complete, cycle both high and low heating modes and cooling modes to verify both are working properly.

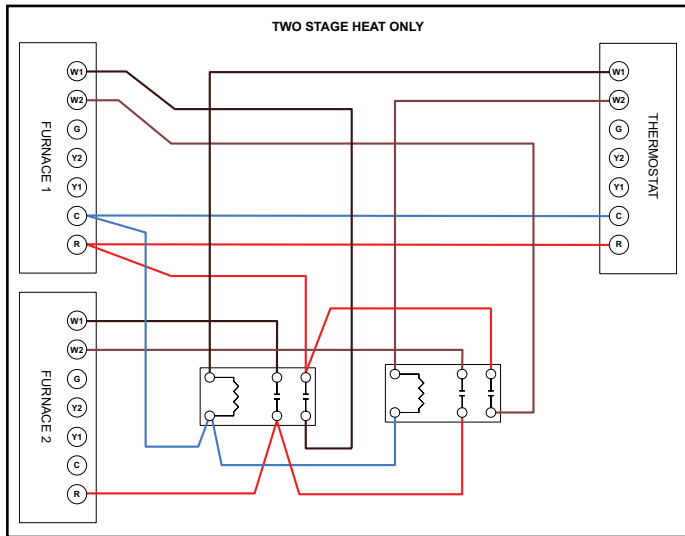

**Figure 4.**

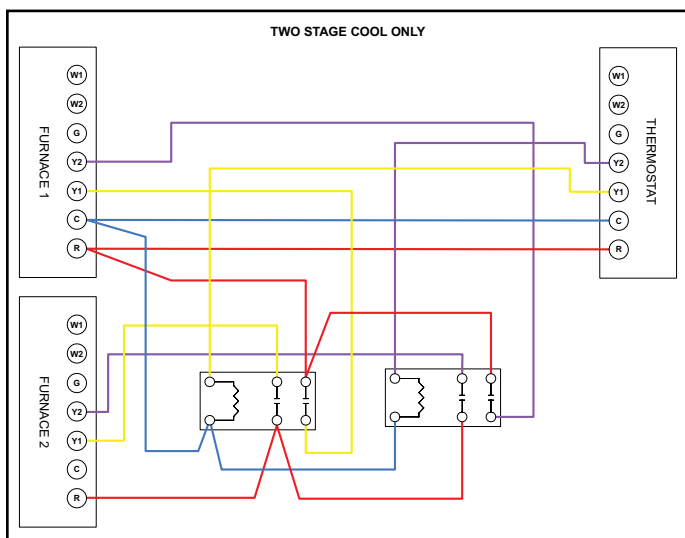

**Figure 5.**

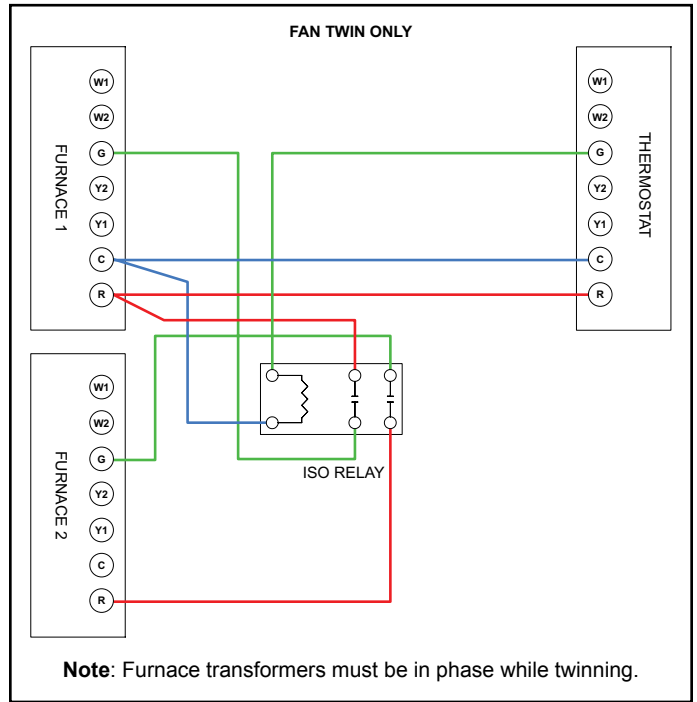

**Figure 6.**