

# GAS UNITS KITS & ACCESSORIES

507856-01  
06/ 2018

## BRASS FITTING KIT

### INSTALLATION INSTRUCTIONS FOR REPLACEMENT BRASS FITTING 16L96 USED WITH LP/PROPANE AND HIGH ALTITUDE LP/PROPANE CONVERSION KITS

#### **⚠ WARNING**

This conversion kit is to be installed by a licensed professional service technician (or equivalent) or other qualified agency in accordance with the manufacturer's instructions, all codes and requirements of the authority having jurisdiction in the USA, and the requirements of the CSA-B149 installation codes in Canada. If the information in these instructions is not followed exactly, a fire or explosion may result causing property damage, personal injury or loss of life. The qualified agency performing this work assumes responsibility for this conversion.

#### Shipping and Packing List

##### Package 1 of 1 contains:

- 1 - Bag Assembly containing :
  - 1 - Gas valve inlet brass fitting

#### Application

This fitting is intended for use in LP/Propane conversion kits 11K44, 11K45, 11K46, 11K47, 11K48, 11K49, 11K50 and 11K51.

#### Installation

#### **⚠ CAUTION**

As with any mechanical equipment, contact with sharp sheet metal edges can result in personal injury. Take care while handling this equipment and wear gloves and protective clothing.

- 1 - Thread provided brass fitting to gas valve inlet until hand tight. Using properly sized wrench, tighten fitting 2 to 3 full turns being careful to position the side port to allow clearance for the pressure switch and harness. See figure 1.

**NOTE** - Never use channel lock pliers or a pipe wrench on the brass fitting.

**NOTE** - Some installations may require the pressure switch and fitting assembly to be positioned differently than shown in figure 1.

- 2 - Thread the gas supply to the brass fitting until hand tight. Using properly sized wrench to support brass fitting, tighten supply line into fitting for a leak free joint. Do not over tighten. Maximum 3 full turns past hand tight for ½" NPT per ASME B1-2013.
- 3 - Thread pressure switch (S145) to brass fitting 2 to 3 turns past hand tight. Re-install pressure switch wiring terminals (if removed).
- 4 - Inspect all sides of the assembly. Turn gas supply on. Immediately check the entire fitting surface and assembly for gas leaks.

#### **⚠ IMPORTANT**

Carefully check all piping connection for gas leaks. DO NOT use matches, candles, open flames or other means of ignition to check for gas leaks. Use a soap solution or other preferred means.

#### **⚠ CAUTION**

Some soaps used for leak detection are corrosive to certain metals. Carefully rinse piping thoroughly after leak test has been completed. Do not use matches, candles, flame or other sources of ignition to check for gas leaks.

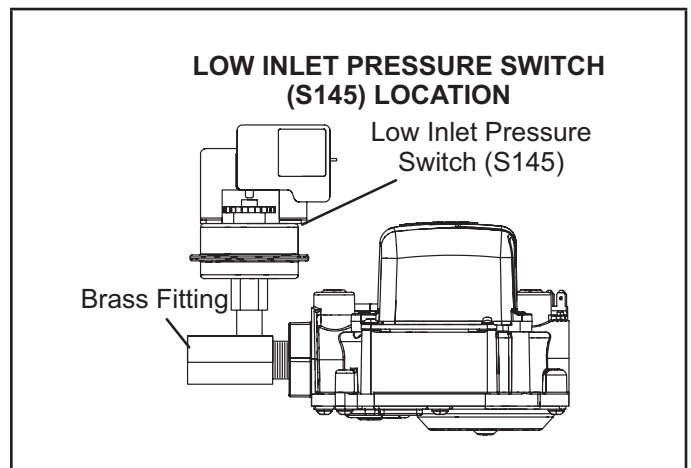

Figure 1