



## THIS MANUAL MUST BE LEFT WITH THE OWNER FOR FUTURE REFERENCE

These instructions are intended as a general guide and do not supersede local codes in any way. Consult authorities having jurisdiction before installation.

### WARNING

Improper installation, adjustment, alteration, service or maintenance can cause property damage, personal injury or loss of life.

Installation and service must be performed by a licensed professional HVAC installer, service agency or the gas supplier.

Failure to follow safety warnings and these instructions exactly could result in property damage, dangerous operation, serious injury, or death.

Any additions, changes, or conversions required in order for the appliance to satisfactorily meet the application needs must be made by a licensed professional HVAC installer (or equivalent) using factory-specified parts.

Do not use this system if any part has been under water. A flood-damaged appliance is extremely dangerous. Immediately call a licensed professional HVAC service technician (or equivalent) to inspect the system and to replace all controls and electrical parts that have been wet, or to replace the system, if deemed necessary.

### CAUTION

As with any mechanical equipment, contact with sharp sheet metal edges can result in personal injury. Take care while handling this equipment and wear gloves and protective clothing.

To ensure proper system performance and reliability, Lennox does not recommend operation of VRF systems during any phase of construction. Construction debris, low temperatures, harmful vapors, and operation of the unit with misplaced filters can damage the units. Failure to follow these guidelines will result in the warranty being voided.

# INSTALLATION INSTRUCTION

## V33B 360° Cassette Units

VRF SYSTEMS -- Indoor Units  
507890-02  
01/2019

### IMPORTANT

The Clean Air Act of 1990 bans the intentional venting of refrigerant (CFCs, HCFCs and HFCs) as of July 1, 1992. Approved methods of recovery, recycling or reclaiming must be followed. Fines and/or incarceration may be levied for noncompliance. These units must be installed as a part of a matched system as specified in the Product Specifications (EHB) bulletin.

### General

The V33B 360° cassette indoor units are matched with an outdoor heat recovery or heat pump unit to create a VRF (variable refrigerant flow) system that uses HFC-410A refrigerant. V33B indoor units are designed for indoor installation only.

Refer to the Product Specification bulletin (EHB) for the proper use of these indoor units with specific heat pumps, heat recovery units, mode switching devices, branch pipes, line sets and controls.

These instructions are intended as a general guide and do not supersede local or national codes in any way. Authorities having jurisdiction should be consulted before installation.

### Shipping and Packing List

Check the components for shipping damage. If you find any damage, immediately contact the last carrier.

Package 1 of 1 contains the following:

- 1 - Assembled indoor cassette unit base
- 8 - Nuts
- 8 - Washers
- 4 - Cover panel screws
- 5 - Wire ties
- 1 - Condensate drain flexible pipe
- 1 - Condensate drain insulation sleeve
- 1 - Clasp
- 1 - Cable
- 2 - Refrigerant pipe insulation
- 2 - Brass flare nuts
- 1 - Template
- 1 - Installation manual

**NOTE** - Assembled indoor unit cover panel is required for complete installation and must be ordered separately.

## Safety Requirements

### WARNING

#### ELECTRICAL SHOCK, FIRE, OR EXPLOSION HAZARD.

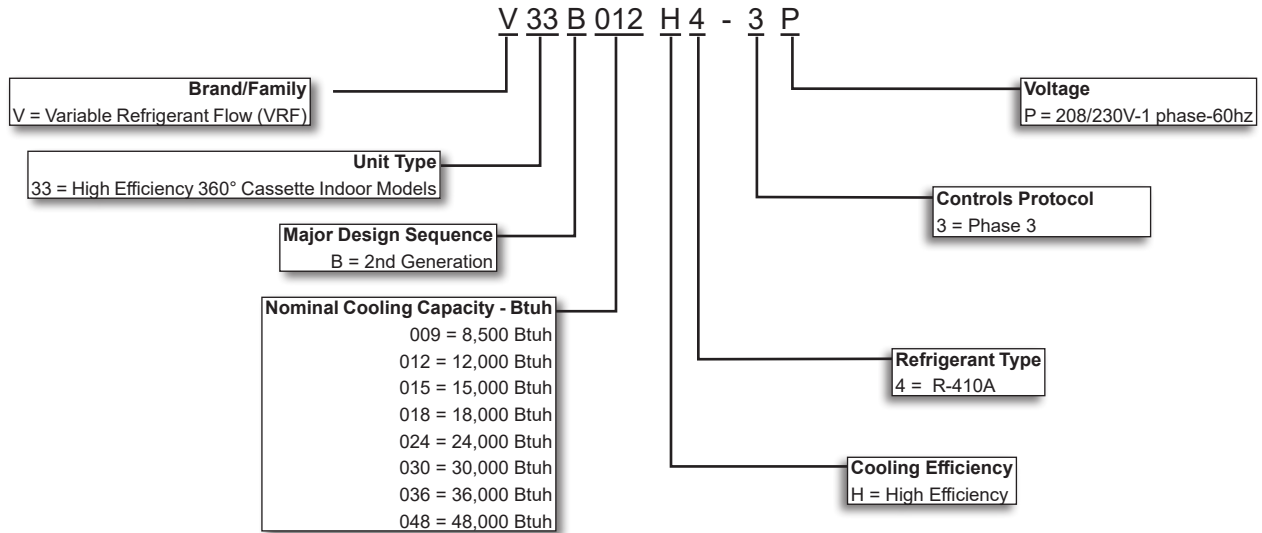
Do not touch the unit or the controller if your hands are wet.

DO NOT spray water on the indoor unit for any reason.

Do not replace a fuse with a fuse of a different rating. Do not use a jumper wire to replace a fuse. Do not insert your hands, tools or any other item into the air intake or air outlet at either the indoor or outdoor unit.

Do not allow children to operate the system.

## Model Number Identification



**NOTE** - Only Lennox VRF indoor units will work with Lennox VRF outdoor units and associated mechanical equipment. Lennox Mini Split indoor units are similar in appearance but must not be connected to a Lennox VRF refrigerant circuit. Please refer to model numbers to confirm compatibility. Model numbers for Lennox VRF units start with a "V" and model numbers for Lennox Mini-Splits start with a "M".

## System Piping

### Caution

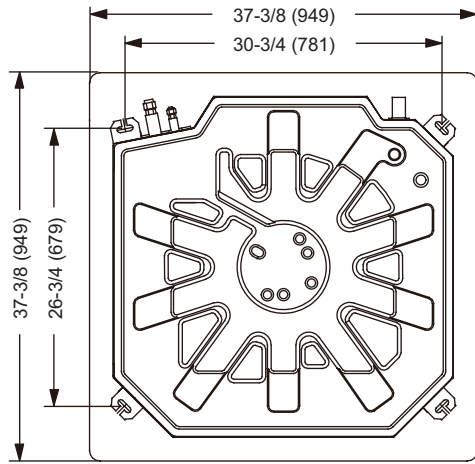
VRF system piping is customized for each installation. The Lennox VRF Selection Software (LVSS) piping report is an engineered design that must be followed. The piping diagram or diagrams included within the LVSS report have been prepared based on the information provided to the Lennox VRF applications department.

When the indicated lengths change from the figures stated within the report, it is imperative that prior to the commencement of the refrigerant pipe work installation, Lennox VRF applications department are informed of these proposed changes.

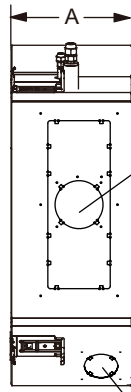
Upon receipt of this new information the Lennox VRF applications department will confirm any changes that may be applicable to this installation. If changes are required, a new piping diagram will be produced and will supersede all other previously provided documents.

Failure to provide this information regarding changes to the original design may lead to insufficient capacity, equipment failure, warranty being made void and the refusal to commission the system.

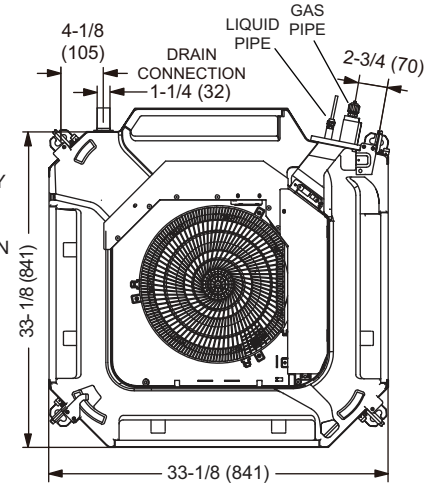
**Unit Dimensions - inches (mm)**



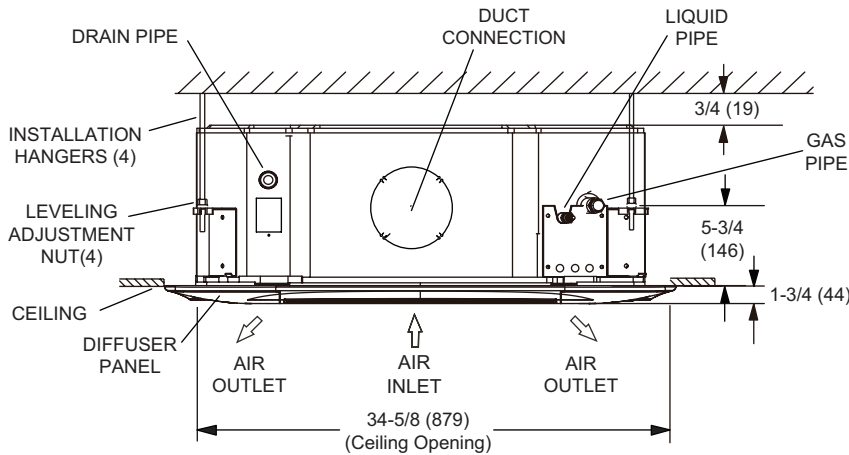
**TOP VIEW**



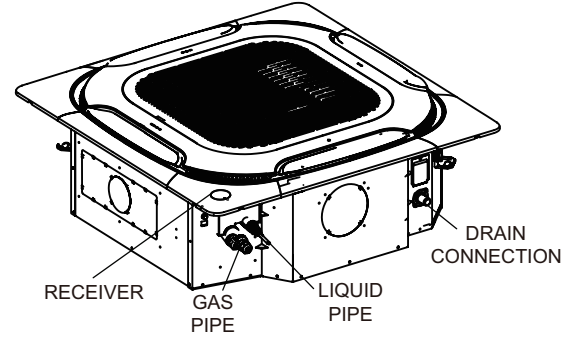
2-3/4 (70) dia. FRESH AIR INTAKE



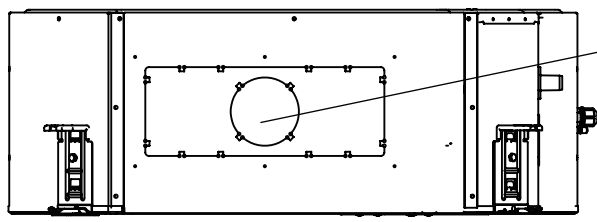
**BOTTOM VIEW**



**SIDE VIEW**



**BOTTOM (PANEL) VIEW**

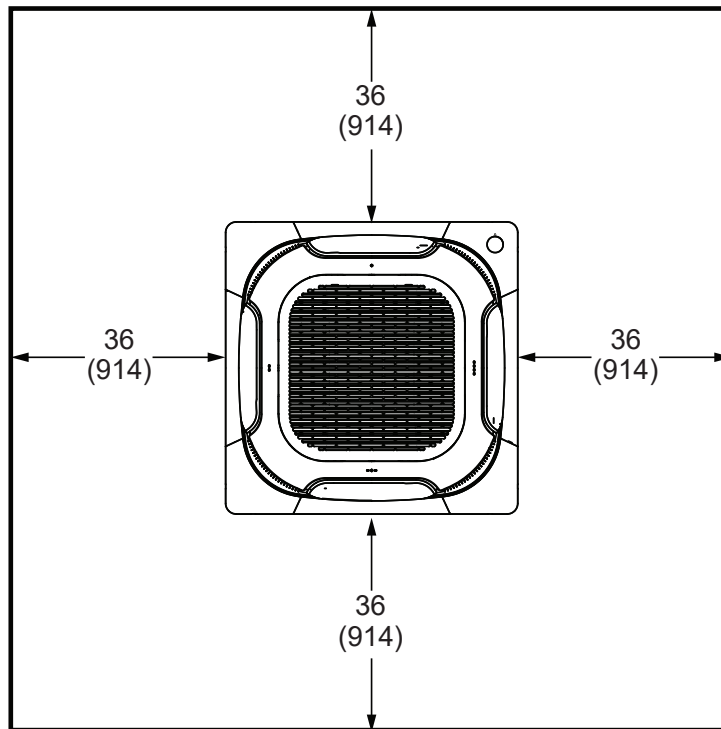


**SIDE VIEW**

Size	A	
	in.	mm
009, 012	9	229
015, 018, 024, 030, 036, 048	11-7/8	302

**NOTE - Horizontal installation only.**

## Clearances



### Minimum Vertical Clearances:

Minimum Clearance from Structural Ceiling to Drop Ceiling:

10-1/4 inches (260 mm) - 007, 009, 012, 015 models

13 inches (330 mm) - 015, 018, 024, 030, 036, 048 models

Minimum Clearance to Floor: 90 inches (2286 mm)

Maximum Clearance to Floor: 160 inches (4064 mm)

Minimum Service Clearance for refrigerant and drain lines - 24 inches (610 mm)

Typical cassette body shown, actual unit may vary.

### **WARNING**

Do not install the unit in an area where flammable materials are present due to risk of explosion resulting in serious injury or death.

Check suitability of structure to which the unit support mechanism will be fixed to. If structure is not capable of carrying the weight of the unit, unit may fall causing personal injury or equipment damage.

Use the provided and specified components when installing equipment. Failure to do so may result in unit falling, water leaking or electrical shocks, causing personal injury or equipment or property damage.

Consider the possibility of earthquakes in your area when installing the equipment. If the unit is not correctly secured, it may fall, causing personal injury or equipment damage.

Safely dispose of packing materials, which include nails, wood and other sharp objects, as well as plastic wrapping. Children playing with plastic wrap or bags risk the danger of suffocation.

### **CAUTION**

Do not place items which may be damaged by water under or around the unit.

The unit should be installed between 90 in. (2286 mm) and 156 in. (3962 mm) above the floor to ensure maximum performance.

### **AVOID**

Do not install the unit in the following locations:

- Areas exposed to salt or other corrosive materials or caustic gases
- Areas exposed to extreme voltage variations (such as factories)
- Tightly enclosed areas that may impede service of the unit.
- Areas exposed to strong electromagnetic forces
- Areas exposed to acids or alkaline detergents (laundry rooms)

DO:

- Locate the unit so that it is central to the area being conditioned.
- Locate the unit so that it is not exposed to direct sunlight.
- Locate the indoor unit so that the room can be uniformly cooled. Install unit at least 90 inches (2286 mm) above the floor, if possible, for best performance.
- Select a structural location that can support the suspended weight of the unit's chassis.
- Select a location where condensate line will have the shortest run to a suitable drain per local codes.
- Allow sufficient space around unit for proper operation and maintenance (filter must be able to be removed from the bottom of the unit).
- Install the indoor unit a minimum of 3 feet away from any antenna, power cord (line), radio, telephone, security system, or intercom. Electrical interference and radio frequencies from any of these sources may affect operation.

## Cassette Base Installation

It is important to locate the cassette unit in the center of the area that is being conditioned. This will provide the best air distribution.

1. If the unit is to be installed in an application that includes a drop-down tile ceiling, remove the ceiling tiles necessary to accommodate installation of the four-way cassette. Before removing the drop ceiling support grid, use a plumb line or laser device to identify the center point of the structural ceiling. **Make sure that the ceiling is supported before removing any of the support grid. It may be necessary to add extra support to maintain the structural integrity of the drop ceiling.**
2. If the unit is to be installed in an application that includes a sheet rock (plasterboard) ceiling, the installation site must be carefully measured and the sheet rock must be cut to accommodate the cassette unit. First, identify the center point of the installed cassette. Use a plumb line to transfer the center mark to the floor for future use. Use the provided template to mark the area of the required opening. Carefully cut the required opening. **Make sure that the removal of the required ceiling support does not affect the structural integrity of the ceiling. It may be necessary to add extra support.**
3. Use the unit as a template or use the provided paper template to mark the location of the hanging brackets on the floor. Use a plumb line or a laser to transfer the bracket positions to the main structural ceiling.
4. **Make sure that structure within ceiling void such as a sub-floor or crawl space is able to support the weight of the cassette unit. It may be necessary to add extra support.** If the structural support is constructed of concrete, install anchors to accept four  $\frac{3}{8}$ " threaded rods to suspend the cassette base. If the structural support includes wooden joists, use angle iron or a Unistrut channel fixed securely in place to accept the  $\frac{3}{8}$ " threaded rods. **NOTE - Threaded rod (requirement of Lennox warranty program) is the ONLY acceptable method of suspending the unit; do not use chains or straps.** See Figure 1.
5. Use either a mechanical lifting device or a minimum of two people to raise the unit and insert the threaded rods into the suspension brackets on the cassette base. Slide a washer and then a nut onto each rod below each suspension bracket. Use the leveling nut (beneath suspension bracket) to adjust the cassette base to the correct height. Remove the electrical tape holding the upper washers and nuts in place and tighten each of the four nuts above the brackets down onto the brackets. This will ensure that the unit remains level.

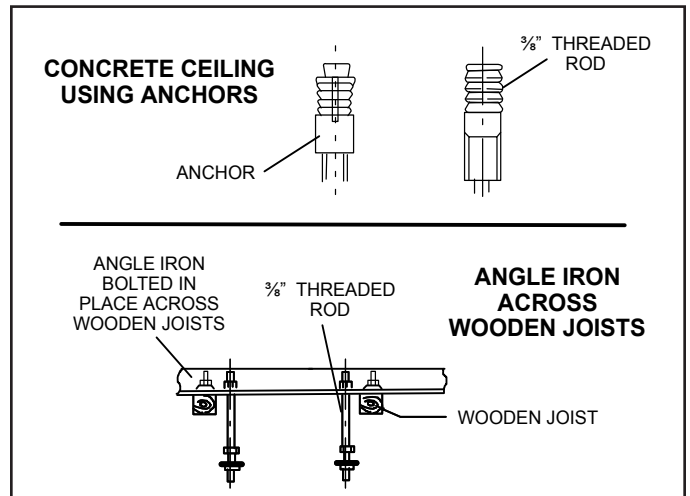


Figure 1. Suspending Methods

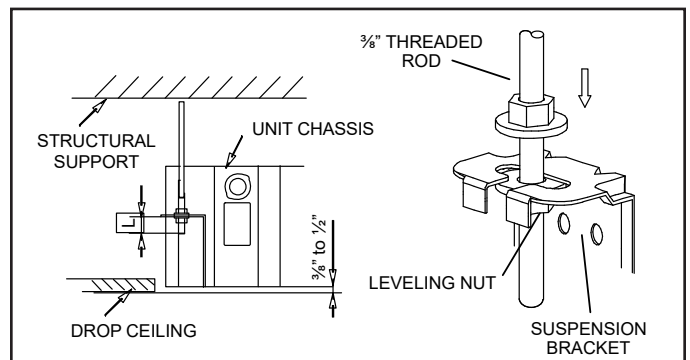


Figure 2. Suspension Hardware

6. If the unit is being installed in an application that includes a sheet rock (plasterboard) ceiling, it is required that an access panel be installed in a suitable location. This will also allow access for future maintenance (requirement of Lennox warranty program).
7. Access is required during the commissioning process to test the condensate disposal system (See Figure 9), to check the electronic expansion valve and associated flare nuts (See Figure 3), and to check the local disconnect. Ceiling framing should not restrict access.

## Refrigerant Piping Connections

### ⚠ WARNING

Refrigerant leaks are unlikely; however, if a refrigerant leak occurs, open a door or windows to dilute the refrigerant in the room. Turn off the unit and all other appliances that may cause a spark. Call a licensed professional HVAC technician (or equivalent) to repair the leak.

Use only R410A refrigerant to charge this system. Use of other refrigerant or gas will damage the equipment.

Do not allow air or other contaminants to enter system during installation of refrigerant piping. Contaminants will result in lower system capacity and abnormally high operating pressures and may result in system failure or explosion.

Insulate all refrigerant piping.

Refrigerant pipes may be very hot during unit operation. Do not allow contact between wiring and bare copper pipes.

After refrigerant piping connections have been completed, check the system for leaks per commissioning instructions.

Field piping consists of two copper lines connected to the indoor unit. Table 1 lists the connection sizes at the indoor unit. The connections are made using the provided brass flare nuts at the end of the refrigerant piping connections.

#### Both lines must be individually insulated.

1. The seal on the unit refrigerant piping connections should remain in place until the last possible moment. This will prevent dust or water from getting into the refrigerant piping before it is connected.
2. Slowly loosen one of the flare nuts to release the factory nitrogen charge.
3. Remove the flare nuts from the connections on the unit and discard the seal from each of the piping connections.
4. Slide the flare nuts onto the ends of the field-provided refrigerant piping **before** using a suitable flaring tool to flare the end of the copper pipe.
5. Apply recommended HFC-410A refrigerant lubricant to the outside of the flared refrigerant lines (Figure 3-A).
6. Align the threaded connections with the flared refrigerant lines. Tighten the flare nuts lightly at first to obtain a smooth match (Figure 3-B).
7. Once snug, continue another half-turn on each nut which should create a leak-free joint. A torque wrench may be used to tighten flare nuts using Table 2 recommendations. See Figure 4. **Do not over-tighten a flared joint. Flared connections should always be accessible and must be insulated to prevent condensation.**

8. After refrigerant piping has been installed and checked for leaks, apply insulation over all flared joints ensuring an air tight seal has been made between unit connections and field supplied insulated piping. All field piping connections shall be insulated and air tight to prevent unwanted condensation build-up. Figure 5.

### ⚠ IMPORTANT!

The compressor in this unit contains PVE oil (Polyvinylether). PVE oil is formulated for hydrofluorocarbon (HFC) refrigerants, such as R-410a, which this system contains. While it may have some miscibility properties with mineral-based oil and POE oil (Polyolester), it is not recommended to mix PVE oil with any other type of refrigerant oil.

Table 1. Refrigerant Piping Connections

Nominal Capacity (Btuh)	Liquid Line in.	Vapor Line in.
9000		
12000	1/4	1/2
15000		
18000		
24000		
30000	3/8	5/8
36000		
48000		

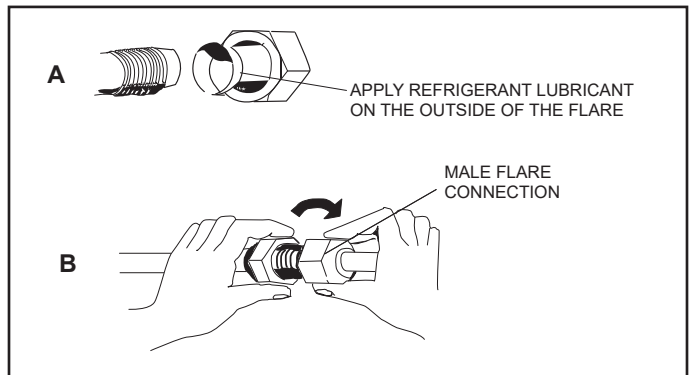


Figure 3. Making Connections  
(Male to Female Connection)

**! IMPORTANT!**

Always use two wrenches when tightening flare nuts to avoid twisting refrigerant piping. DO NOT over-tighten flare nuts.

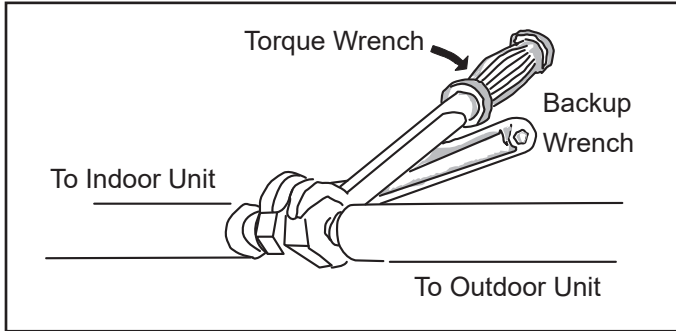


Figure 4. Tighten Flare Nut

Table 2. Flare Nut Torque Recommendations

Outside Diameter	Recommended Torque	No torque wrench available Finger tighten and use an appropriately sized wrench to turn an additional:
Inches	U.S.	
1/4"	15 ft.-lb.	1/4 turn
3/8"	26 ft.-lb.	1/2 turn
1/2"	41 ft.-lb.	7/8 turn
5/8"	48 ft.-lb.	1 full turn

**! IMPORTANT**

Flared connections should always be accessible and must be insulated to prevent condensation. See Figure 5.

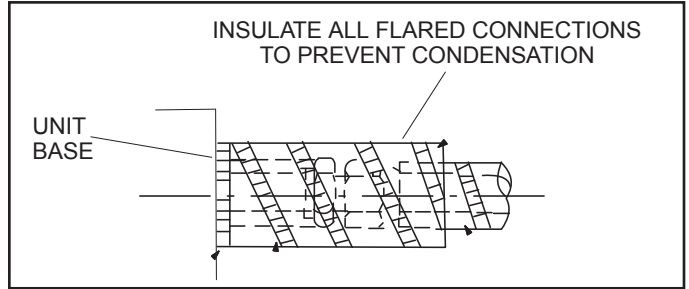


Figure 5. Insulate Flared Connections

**! IMPORTANT**

Support ALL piping within 12 in. (305 mm) of any mechanical fitting such as a flared connection.



## Condensate Piping Connections

### ⚠ CAUTION

Make sure that drain piping is properly routed and insulated in order to prevent both leaks and condensation.

1. Use the provided hose clamp to secure the provided flexible condensate drain connector to the drain line stub on the side of the cassette base. Wrap the flexible connector with the provided insulation. **NOTE - Take care not to over-tighten the hose clamp as this may damage the drain line stub.**
2. Make a water-tight connection between the field-provided condensate drain line and the flexible condensate connector. Use 1-1/4" OD PVC pipe for the drain line.
3. See Figure 6 for applications including a single unit and a single drain. In this case, ensure that the drain line is properly sloped (no less than 1/4 inch per foot) and condensate lines are routed to ensure moisture is drained away from the indoor unit.
4. See Figure 7 for applications including multiple units using the internal pump to provide lift into a single, correctly sized main drain. In this case, ensure that the main drain line is properly sloped (no less than 1/4 inch per foot) and that each individual drain is connected to the main drain exactly as shown.
5. Drain should be as short as possible and should not have any droops or kinks that would restrict condensate flow and shall be approved resistant pipe.

6. After system installation is complete, the condensate drain line must be checked for leaks and the condensate pumps must be checked to ensure proper operation. This check is part of the commissioning sequence. Pour water into the evaporator drain pan to ensure proper condensate drainage. See Figure 8. If a leak is found, shut down power to the unit at once and do not restore power to the unit until the problem has been resolved.

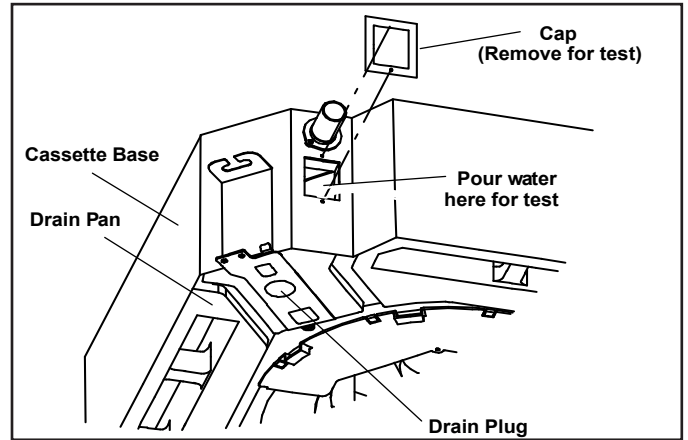


Figure 8. Test Condensate Drain

### ⚠ IMPORTANT!

Drain should have a slope of at least 1/4 inch per foot and should be approved corrosion-resistant pipe. You must confirm operation of every drain and pump in the system as part of the commissioning procedure.

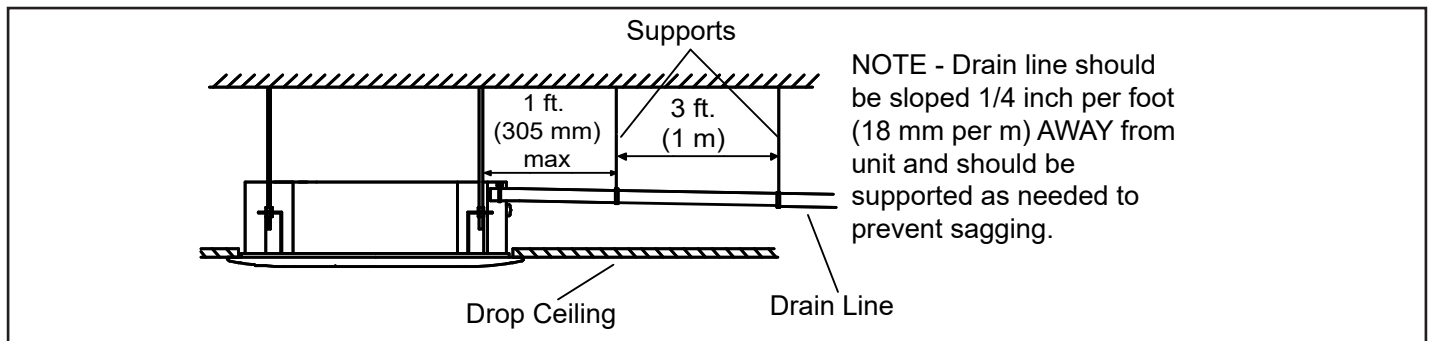


Figure 6. Sloped Condensate Drain -- Single Unit

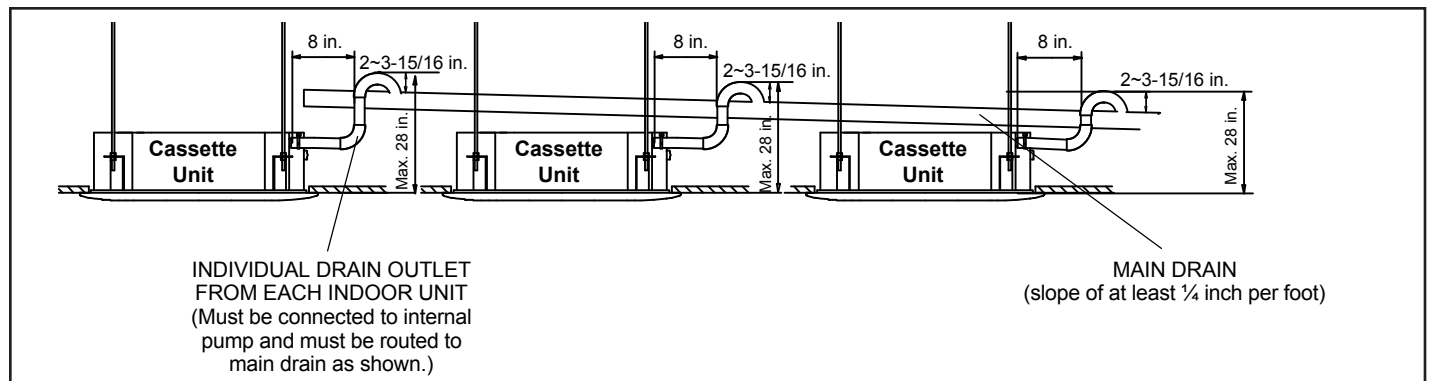


Figure 7. Using a Main Drain to Serve Multiple Indoor Units

## Wiring Connections

### ⚠ WARNING

Isolate the power supply before accessing unit electrical terminals.

Install unit so that unit disconnect is accessible.

Follow all local and national codes, as well as this installation instruction, during installation. Do NOT overload electrical circuit, as this may lead to failure and possible fire.

Use specified wiring and cable to make electrical connections. Clamp cables securely and make sure that connections are tight to avoid strain on wiring. Insecure wiring connections may result in equipment failure and risk of fire.

Wiring must be installed so that all cover plates can be securely closed.

In the U.S.A., wiring must conform with current local codes and the current National Electric Code (NEC). In Canada, wiring must conform with current local codes and the current Canadian Electrical Code (CEC).

Refer to unit nameplate for minimum circuit ampacity and maximum overcurrent protection size.

1. Remove the screws that secure the control box cover. Remove the cover and place it to the side where it will not be damaged.

### ⚠ CAUTION

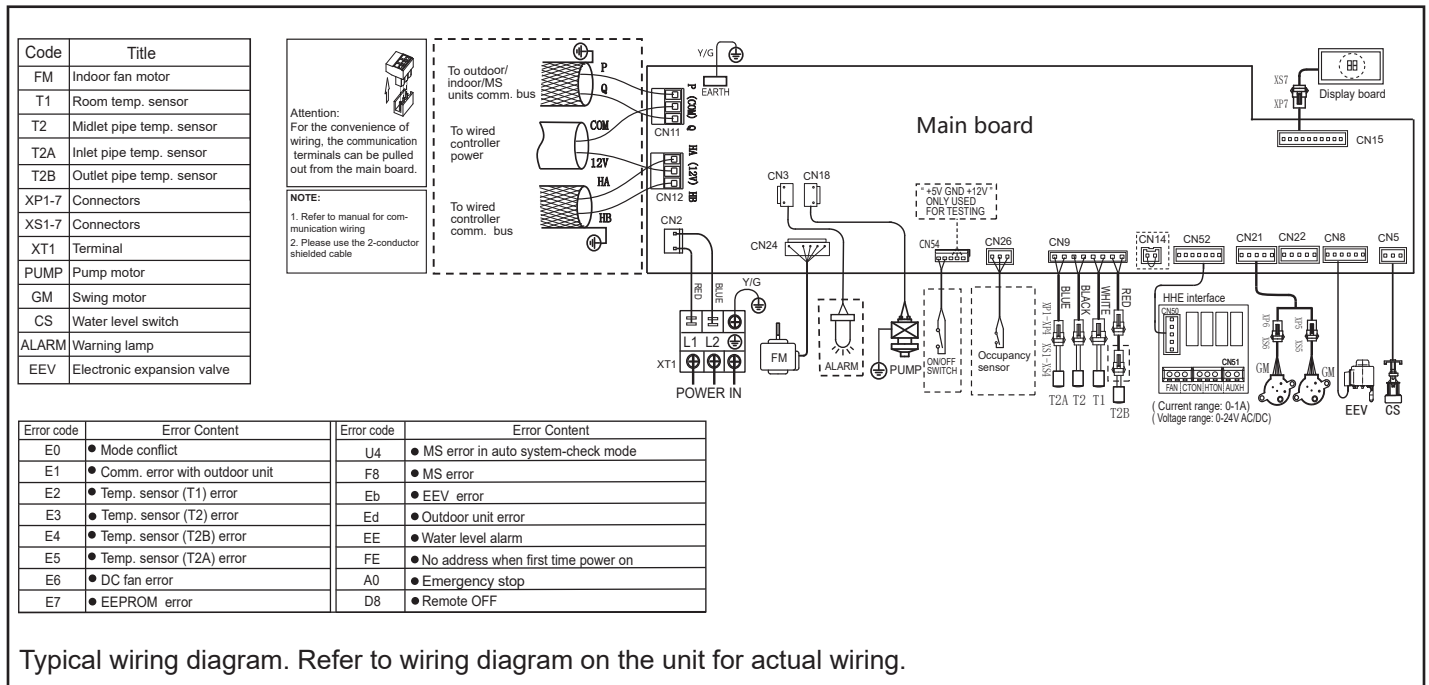
This unit must be properly grounded and protected by a circuit breaker. The ground wire for the unit must not be connected to a gas or water pipe, a lightning conductor or a telephone ground wire.

Do not connect power wires to the outdoor unit until all other wiring and piping connections have been completed.

Install all wiring at least 3 feet away from televisions, radios or other electronic devices in order to avoid the possibility of interference with the unit operation.

Do not install the unit near a lighting appliance that includes a ballast. The ballast may affect remote control operation.

2. Locate the terminal strip in the control box. Connect the power wiring (sized per NEC/CEC and local codes) and communications cable (per Figures 10, 11 and 12. Refer to unit nameplate for rated voltage.

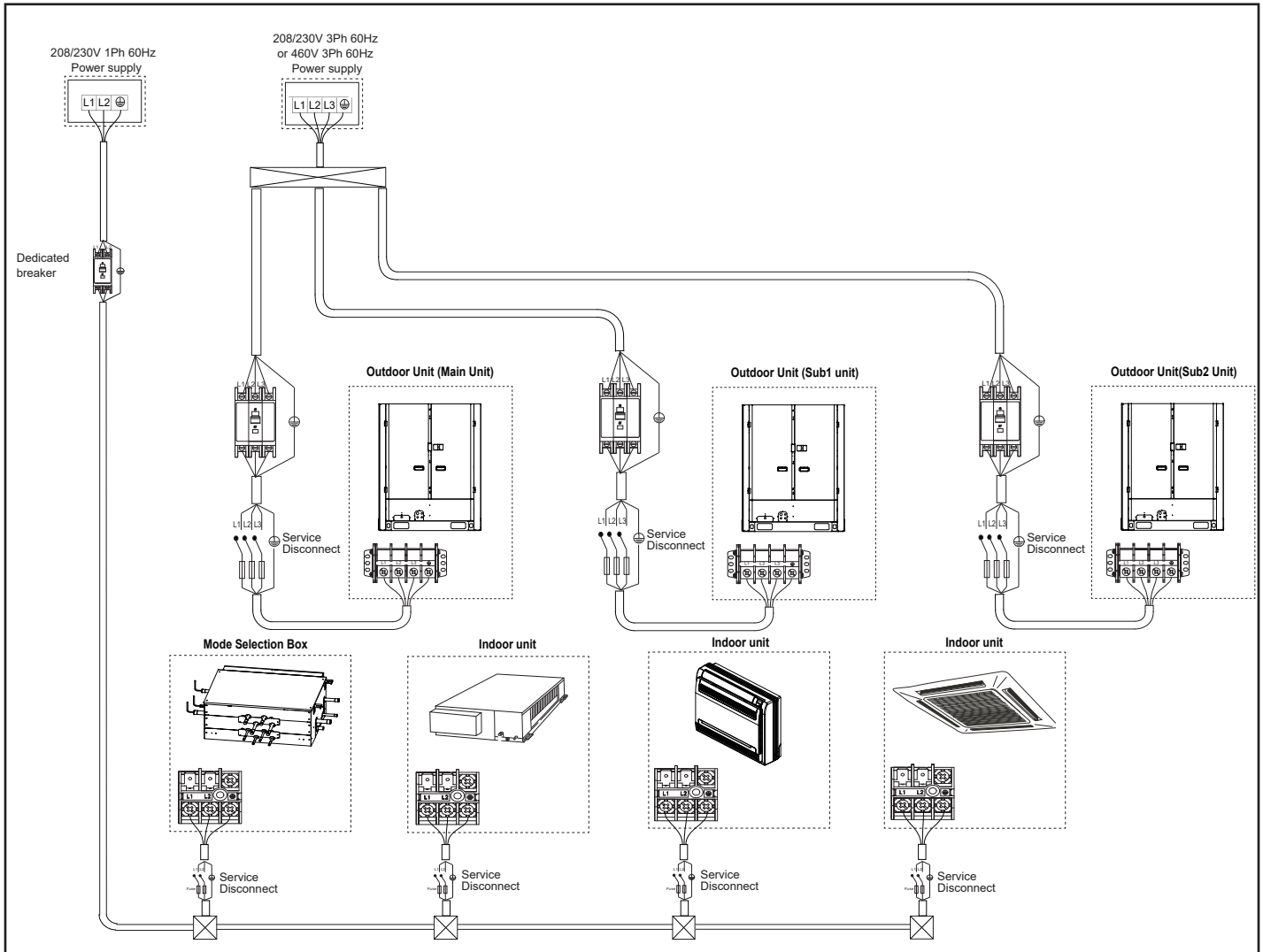


Typical wiring diagram. Refer to wiring diagram on the unit for actual wiring.

Figure 9. Typical Wiring Diagram V33B Wiring Diagram

Indoor units and mode selection boxes on the same refrigeration circuit should have a common power supply but must have an independent disconnect switch installed adjacent to each item of equipment for servicing and maintenance purposes.

Indoor unit and mode selection box power supply MUST not be taken from the outdoor unit. Always follow NEC/CEC and Local Codes.



**Figure 10. Typical Power Wiring Diagram (VRF Heat Recovery System Shown)**

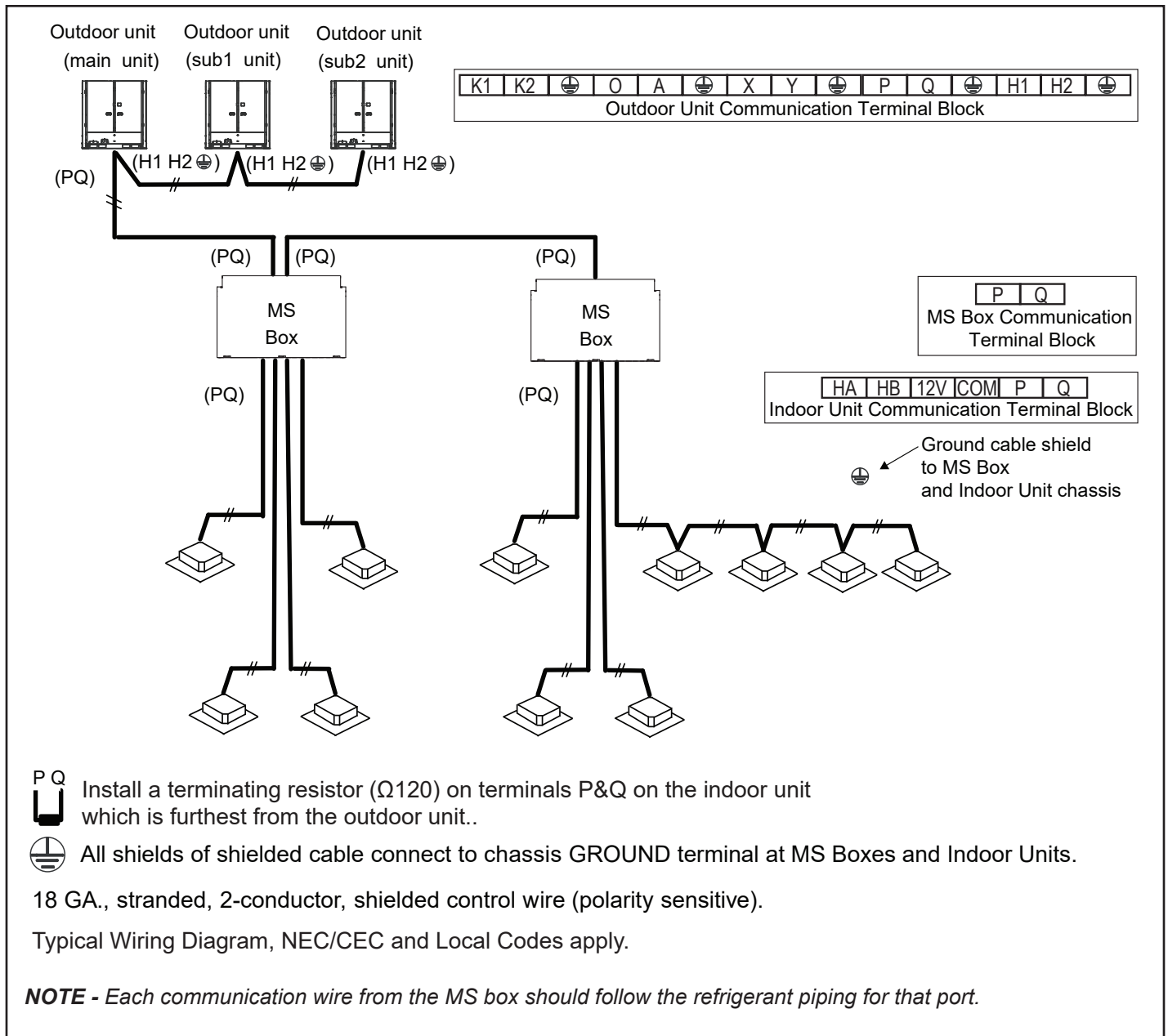


Figure 11. Typical Communication Wiring Diagram (VRF Heat Recovery System)

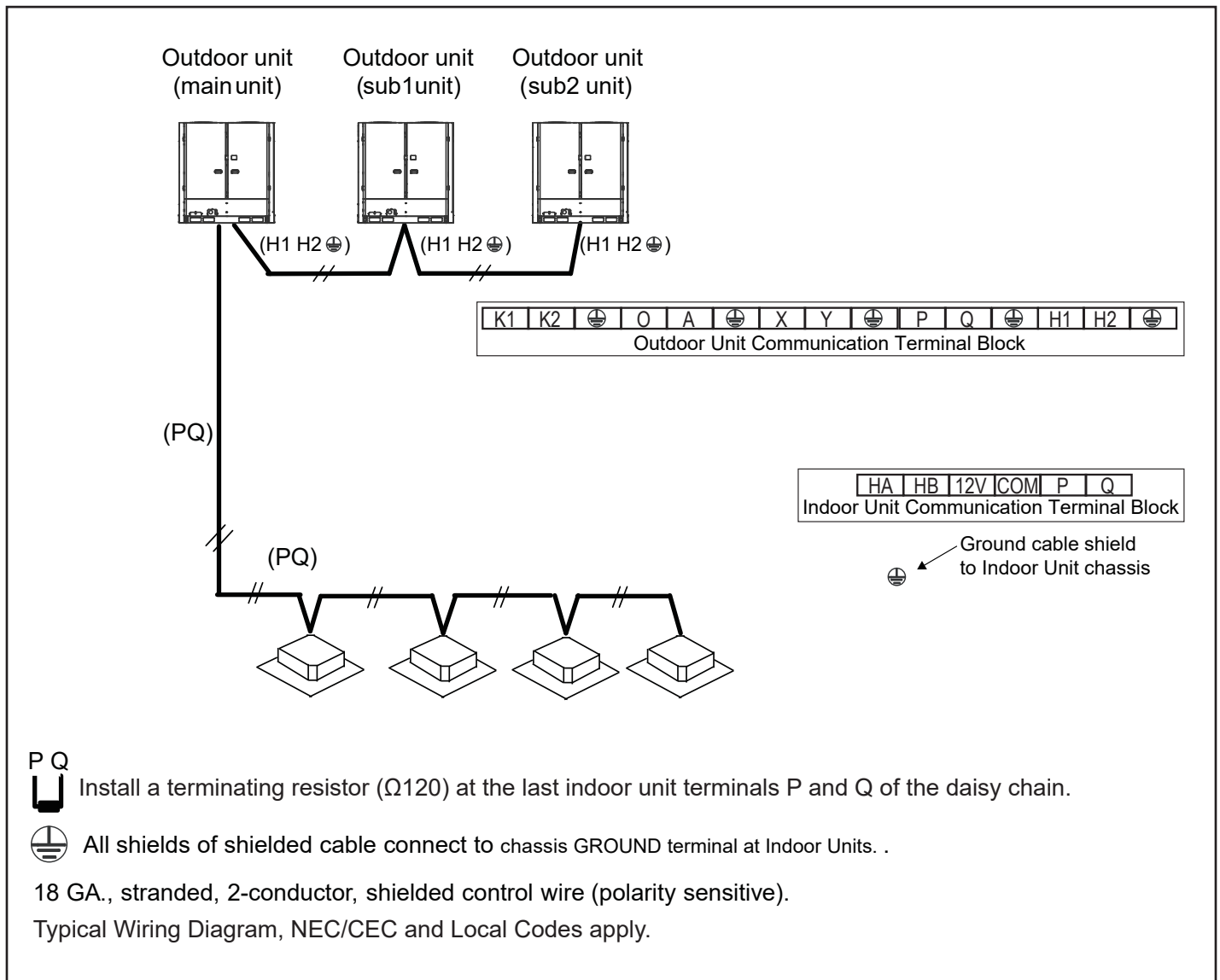


Figure 12. Typical Communication Wiring Diagram (VRF Heat Pump System)

### Tightening torque for the terminal screws

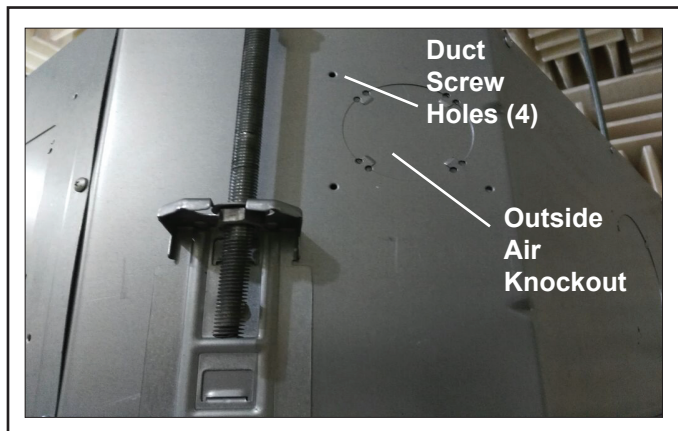
- Use the correct screwdriver for fighting the terminal screws. If the screwdriver blade is too small, the head of the screw might be damaged, and the screw will not be properly tightened.
- If the terminal screws are over tightened, screws might be damaged.
- Refer to the table below for the tightening torque of the terminal screws.
- After wiring, confirm all connections are correct; Then turn on power supply to the unit.

Table 3. Terminal Screw Tightening Torque

	Tightening torque (lb-ft)
Terminal base of remote controller/Signal transmission wire (X2M)	0.58-0.72
Terminal base of power supply (X1M)	0.87-1.06
Grounding terminal (M4)	1.06-1.43

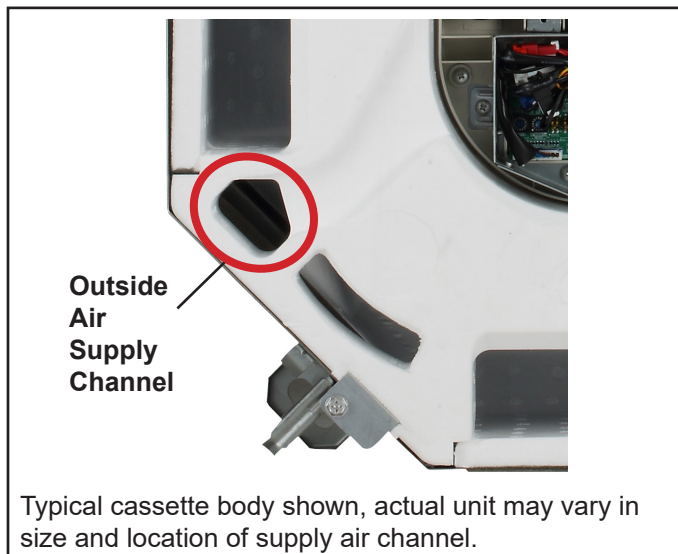
## Outside Air Connection

A limited amount of filtered outside air can be brought into the cassette unit [through the 3 inch (76 mm)] outside air knockout to be conditioned and mixed into the supply air.



**Figure 13. Typical Outside Air Knockout**

1. Knock out the outside air supply opening. See Figure 13.
2. Remove any insulation.
3. Make sure the outside air supply channel is clear of styrofoam and debris. See Figure 14.
4. Connect the outside air duct to cassette body using the four screw holes shown in Figure 13.



**Figure 14. Typical Outside Air Supply Channel**

5. Relocate the indoor unit's return air sensor to either the controller (electronically) or physically by using the remote sensor accessory.
6. The outside air supply duct length must be 10 feet or less.
7. Use a field-supplied booster fan to increase static pressure.

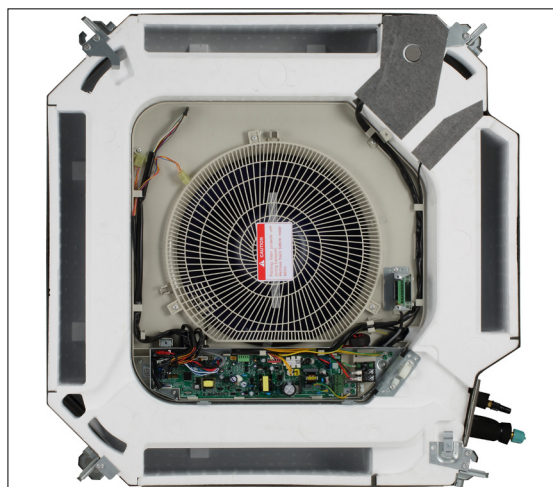
## Supply Air Configurations

Supply air is typically provided from all four sides of the cassette unit. See Figure 15.

If needed for the application, one or two sides of the cassette supply air can be blanked off to prevent air flow from that side. See Figures 16 and 17 for possible air flow configurations.

Use field-provided blocking and sealing materials. Materials must be listed ANSI/UL and ASTM E 84 approved.

**NOTE** - A maximum of two sides can be blanked off.



Typical cassette body shown, actual unit may vary in size and location of supply air openings.

**Figure 15. Typical Supply Air Configuration**

1. Remove the decorative cover panel if installed.
2. Identify and measure the supply air opening that will be blanked off. See Figure 15.
3. Prepare the blocking material. Cut a piece of styrofoam or other non-conductive material to fit the supply air opening.
4. Insert the blocking material into the supply air opening.
5. Prepare the sealing material. Cut a piece of tape or other non-conductive sealing material to cover and secure the blocking material.
6. Seal the supply air opening using the sealing material.
7. Install the decorative cover panel.

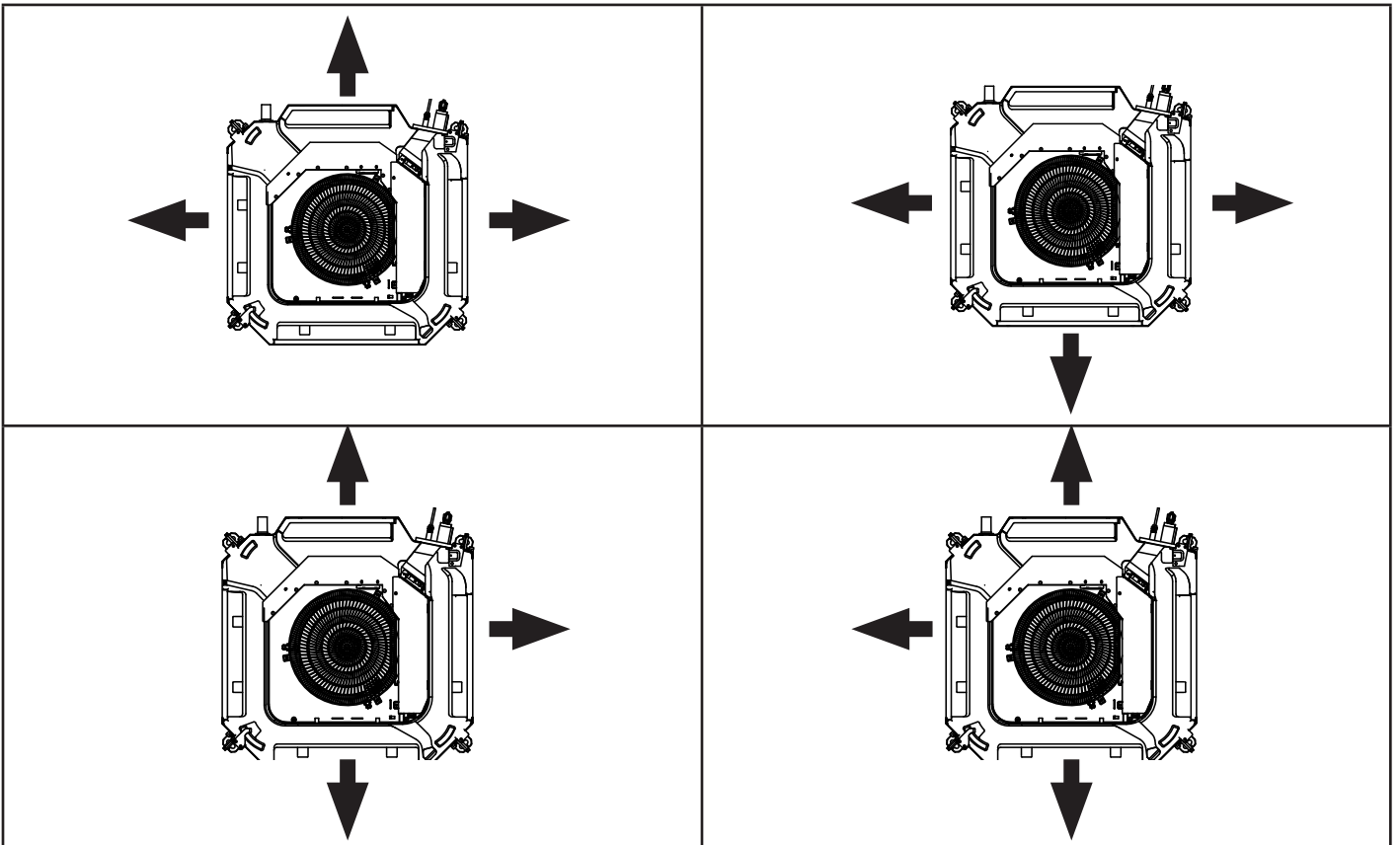
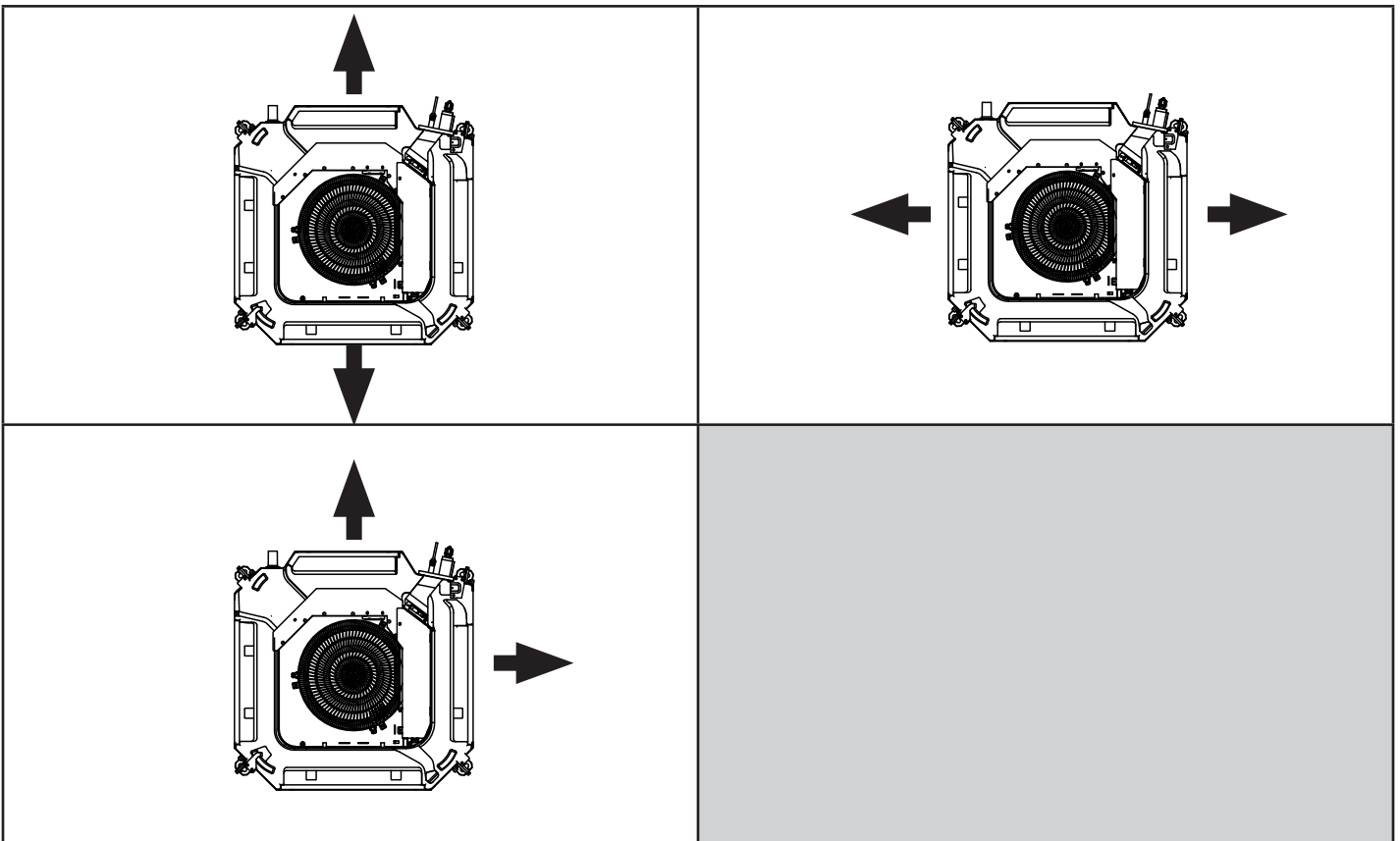


Figure 16. Three-way Outlet Possible Flow Patterns



Typical cassette body shown, actual unit may vary.

Figure 17. Two-way Outlet Possible Flow Patterns

## Installation of Secondary Supply Duct

A limited amount of conditioned air can be diverted through a small duct to a location outside of the zone. For example, a common application is for the cassette unit to serve an office that has a small attached bathroom. Air can be supplied to the bathroom from the cassette unit by following these instructions.

**NOTE** - Secondary supply duct knockouts are located on all four sides of the V33B cassette body. If the knock out is used, the supply air opening of the same side should be blocked and sealed.

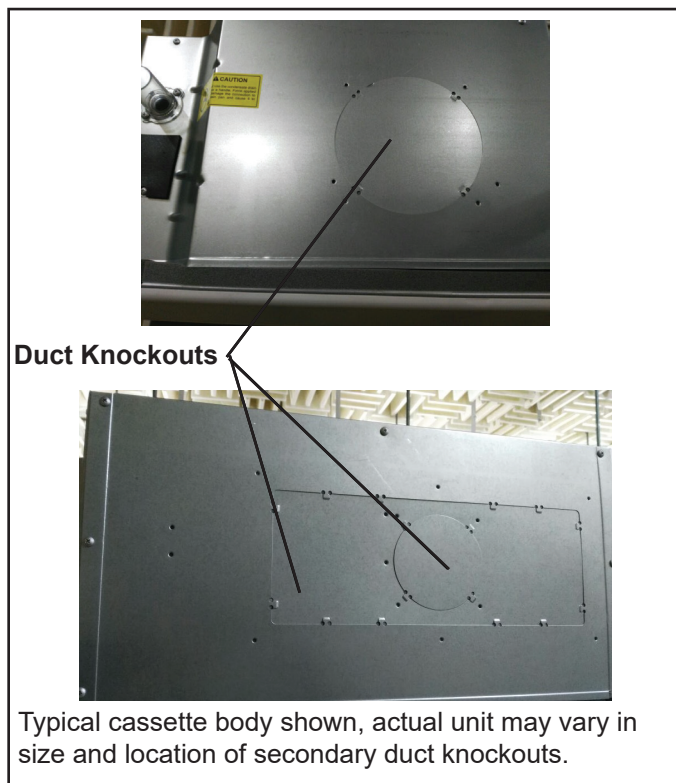


Figure 18. Typical Duct Knockout

1. Decide which side of the cassette body will be ducted.
2. Seal the supply air outlet on the side to which the duct will be attached. See the Supply Air Configurations section for detailed instructions.
3. Knockout the secondary supply duct opening. See Figure 18.
4. Remove any insulation.
5. Connect the secondary supply duct to the cassette body using the eight screw holes shown in figure 18.
6. A field-supplied duct transition may be required. Be sure there is an air-tight seal between the transition and the cassette body and between the transition and the secondary supply duct.
7. The secondary supply duct must be 4 or 6 inches in diameter and 10 feet or less in length (including transitions).

**NOTE** - A field-supplied volume control damper can be used to control the amount of air supplied to the space, however, the area being conditioned by the secondary supply duct will not have control over the temperature of the air being supplied.

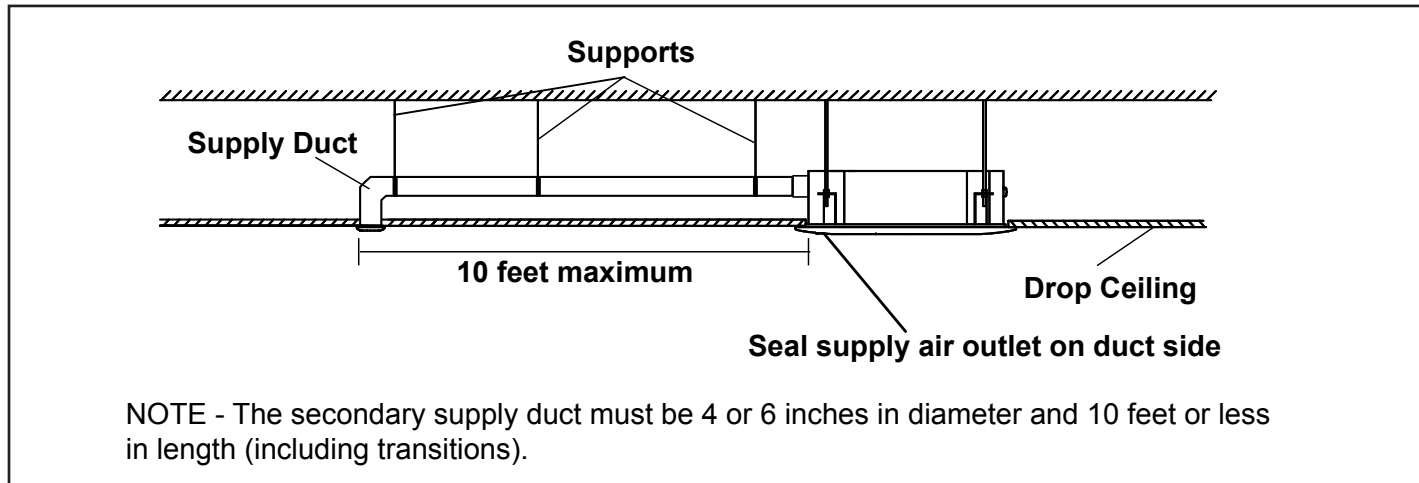


Figure 19. Supply Duct Maximum Length



## Cassette Cover Panel Installation

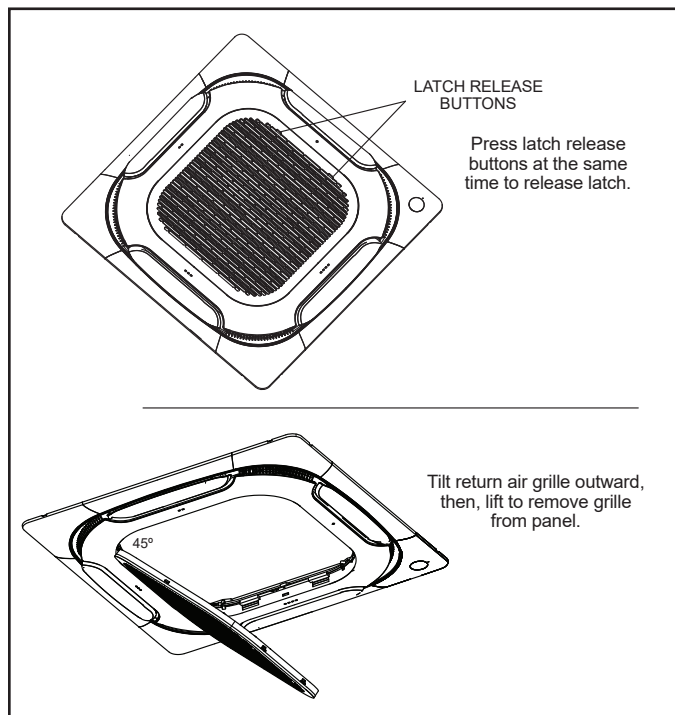
**NOTE** - Cover panel must be ordered as a separate accessory.

1. Carefully remove the cassette cover panel from its protective packaging and place the panel diffuser-side-out on a clean, level surface.

### CAUTION

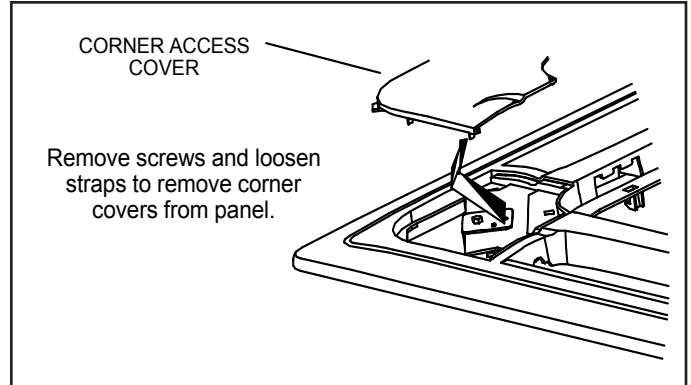
Do not place the cover panel with the diffusers face down on the floor or other surface. Louvers will be damaged if pressure is applied to them.

2. Press the two grille latch release buttons at the same time to release the grille. See Figure 20. Tilt the return air grille outward at a 45° angle and lift the grille away from the panel. Carefully place the return air grille off to the side.



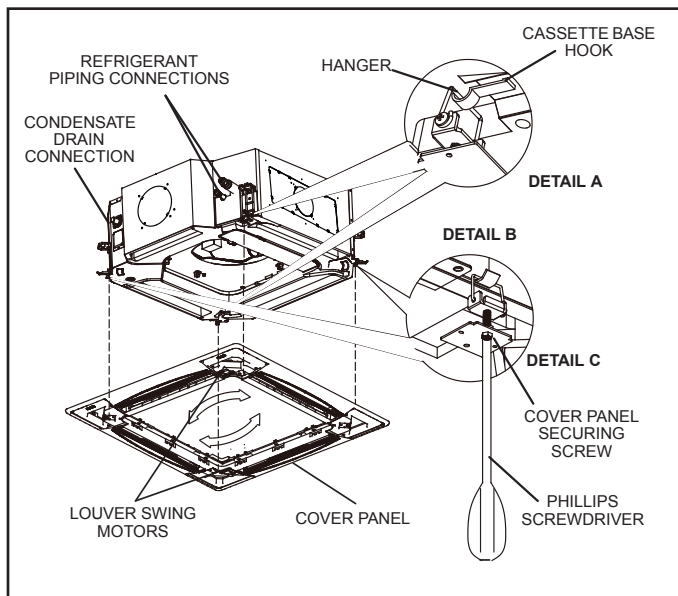
**Figure 20. Remove Return Air Grille**

3. Remove access covers from each corner of the panel. See Figure 21.



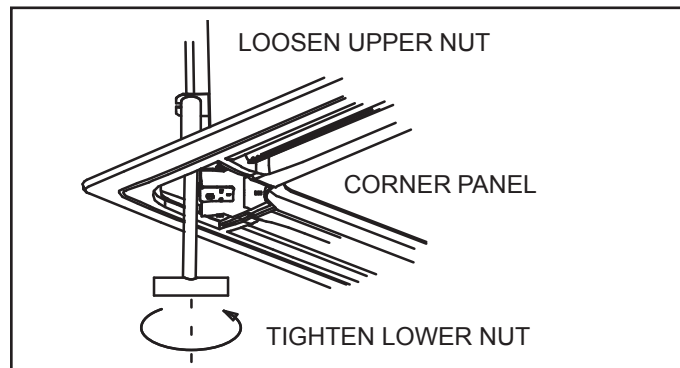
**Figure 21. Remove Corner Covers**

4. Position the ceiling panel so that the arrow on the panel is aligned with the arrow sticker on the cassette base (both arrow stickers should be on the same side of the cassette base). **NOTE** - If the panel and the base are not properly aligned, the airflow will be blocked and the harness plugs from the panel to the cassette base will not be long enough to plug together.
5. Locate the cover panel hangers on the two corners with the louver swing motors. Place these two hangers on the corresponding hooks on the corners of the cassette base. See detail A in Figure 22. Then, place the other hangers from the other two corners over their corresponding hooks on the cassette base as shown in detail B in Figure 22.
6. Connect the six-pin harness plugs from each of the two swing motors to the matching six-pin plugs from the control box in the cassette base.
7. Connect the black harness from the display on the cover panel to the corresponding black plug from the control box in the cassette base.

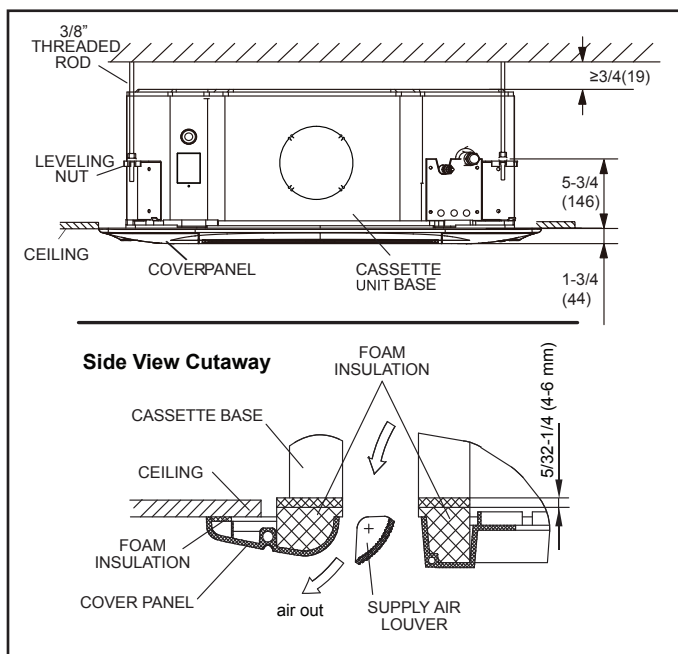


**Figure 22. Install Cover Panel**

8. Tighten the provided screws in the bracket in the cover panel immediately below each panel hanger. See detail C in Figure 22. Adjust the cover panel by turning slightly clockwise, if necessary, to make sure that the panel is properly aligned with the cassette base.



**Figure 24. Adjust Unit Height Through Corner Panel**



**Figure 23. Cover Panel in Place**

9. Continue to tighten the cover panel securing screws until the insulation between the cover panel and the cassette base has been compressed to approximately  $\frac{1}{4}$ ". The cover panel must form a seal with the ceiling and the cassette base around the entire perimeter of the unit. See Figure 23.
10. If it is necessary to adjust the cassette height after the cover panel has been installed, access the leveling nut through the removable access cover on each corner. See Figure 24.
11. The return air grille must be reinstalled on the cover panel. Align the four tabs on the grille with the four slots in the cover panel. Tilt the panel back into place. Press the opposite side of the cover gently until the latches engage.

## Network Address and Commissioning

After the system has been installed, each indoor unit must be assigned an address as part of the commissioning procedure.

## Spot Check Instructions

Use the Spot Check Performance tables below and the Manual button on the unit receiver to view diagnostic information the indoor unit.

**Table 4. Spot Check Performance Identification Table**

No.	Content	Recorded Value/Date
0	Normal display	
1	Communication address of indoor unit	
2	Indoor unit capacity (horsepower)	
3	Network address of indoor unit	
4	The actual setpoint temperature	
5	The actual indoor temperature T1	
6	The middle coil temperature T2	
7	The coil inlet temperature T2A	
8	The coil outlet temperature T2B	
9	The actual superheat temperature	
10	The actual subcool temperature	
11	Error Code	
12	Indoor software version	
13	End (--)	

This Spot Check Performance table is located on the unit service panel.

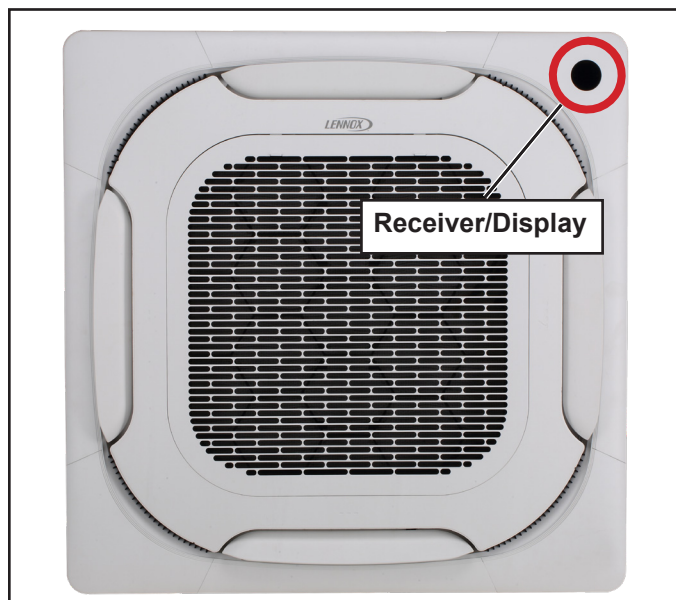
The diagnostic information can also be obtained using the wired remote controller.

## Troubleshooting

### Digital Display

The indoor unit is equipped with a receiver that has a digital display that provides an error code. Refer to the table below to view the error codes. The error code will replace the temperature setting displayed on the receiver. If more than one error has occurred, the codes will alternate so that all codes are shown.

Make note of the code (E1, EE, etc.), then reset the display by pressing the ON/OFF button on the unit controller. Press the ON/OFF button a second time to reapply power to unit. If the code is still displayed, disconnect and restore power at the unit disconnect switch or circuit breaker. If the problem was temporary, the code will not reappear. If the error code reappears after power has been broken and restored at the disconnect switch or circuit breaker, call VRF Technical Support 1-844-438-8731.



**Figure 25. Cover Panel**

**Table 7. Fault Code Display on Indoor Unit Receiver**

Error Code	Description
FE	No address
E0	Mode conflict
E1	Communication error between indoor and main outdoor unit
E2	T1 (Room temperature sensor) malfunction
E3	T2 (Middle of evaporator sensor) malfunction
E4	T2B (Outlet of evaporator sensor) malfunction
E5	T2A (Inlet of evaporator sensor) malfunction
E6	DC fan motor error
E7	EEPROM failure
Eb	EXV malfunction
Ed	Outdoor unit Fault
EE	High Water Alarm
A0	Emergency stop
D8	Remote off
U4	MS self-inspection error
F8	MS error

**Table 8. Fault Code Display on Controller**

Error Code	Description
F0	Communication/Address error between indoor units and wired controller
F1	Communication/Wiring error between indoor units and wired controller
E2	Controller temperature sensor error

**Technical Support**

1-844-GET-VRF1

(1-844-438-8731)

vrftechsupport@lennoxind.com

www.LennoxVRF.com

Download the app  
from the Apple App Store or the Google Play store.

