

ROOFTOP UNIT KITS AND ACCESSORIES

507990-01
10/2019

BLOWER HOUSING REPLACEMENT KIT

INSTALLATION INSTRUCTIONS FOR BLOWER HOUSING REPLACEMENT KIT (19H49 & 19H50; 621156-05 & 06) USED WITH SGH/SCH036 & 060 UNITS

Shipping and Packing List

Package 1 of 1 contains:

- 1- Blower housing

⚠ WARNING

Improper installation, adjustment, alteration, service or maintenance can cause property damage, personal injury or loss of life. Installation and service must be performed by a licensed professional HVAC installer or equivalent, service agency, or the gas supplier

⚠ CAUTION

As with any mechanical equipment, contact with sharp sheet metal edges can result in personal injury. Take care while handling this equipment and wear gloves and protective clothing.

Application

The blower housing replacement kit is used on SGH/SCH036 & 060 unit direct drive blowers. 19H49 (621156-05) does not have corrosion protection. 19H50 (621156-06) has corrosion protection.

Remove Housing

- 1- Disconnect electrical power to unit. Wait five minutes before continuing service procedures to avoid electrical shock. This will allow internal capacitors time to fully discharge.
- 2- Open access panels as shown in figure 1.
- 3- Disconnect J48 from P48 and J335 from P335 in the controls area. See figure 2.

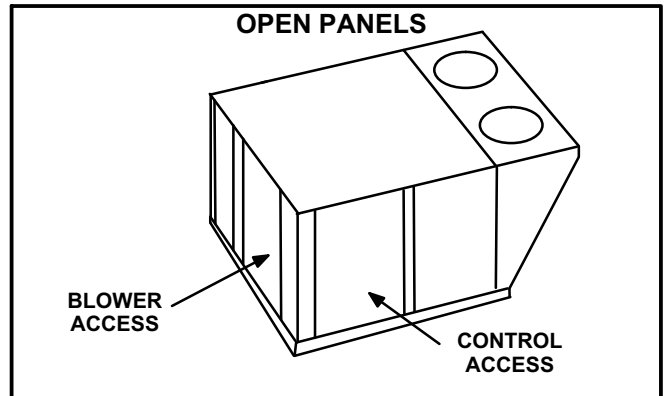

FIGURE 1

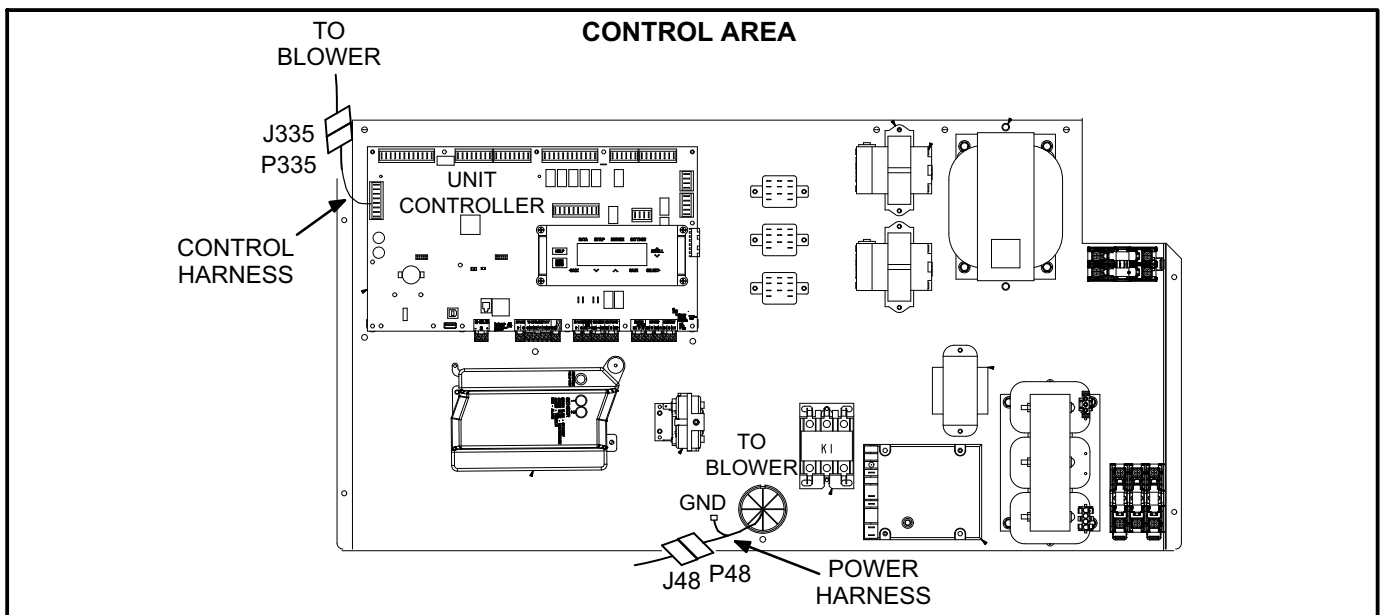

FIGURE 2

- 4- Cut wire ties where necessary and pull P48 and J335 wiring harnesses from control area into blower section. The top panel may need to be raised to pull the control harness through the convoluted tubing in between the blower and controls section.
 - 5- Remove four screws securing blower assembly to unit. See figure 3.
 - 6- If unit was equipped with an optional blower proving switch, remove switch from existing blower housing.
 - 7- Use the handle on the blower assembly to slide the assembly out of unit.
 - 8- Turn the blower assembly upside down. See figure 4.
 - 9- Remove the inlet grill, orifice and the side of the housing shown in figure 5.
 - 10- Remove the motor / impeller secured to the existing housing. See figures 4 and 5.
 - 11- Discard existing housing.
- 2- Install existing motor / impeller on replacement blower housing in the same manner the motor / impeller was removed from the discarded housing. Secure with 6 bolts provided in this kit. Tighten to 21.7 ft.-lbs.
 - 3- Replace the blower housing side, orifice and inlet grill which was previously disassembled. Tighten orifice screws to 10.8 ft.-lbs. Tighten inlet grill screws to 3.7 ft.-lbs.
 - 4- If previously removed, attach the optional blower proving switch to replacement housing in the same manner it was removed.
 - 5- Install blower assembly flanges into rails on the blower deck in the same manner the discarded housing was removed. Secure into place using four screws shown in figure 3.
 - 6- Route P48 and J335 end of harnesses through unit to control area in the same manner as they were removed.
 - 7- Connect P48 and J335 to J48 and P335 as shown in figure 2.
 - 8- Bundle harnesses and use wire ties to secure kit harnesses to unit harnesses in the same manner they were removed.

Install Replacement Housing

- 1- Remove one side of the replacement housing. See figures 4 and 5.

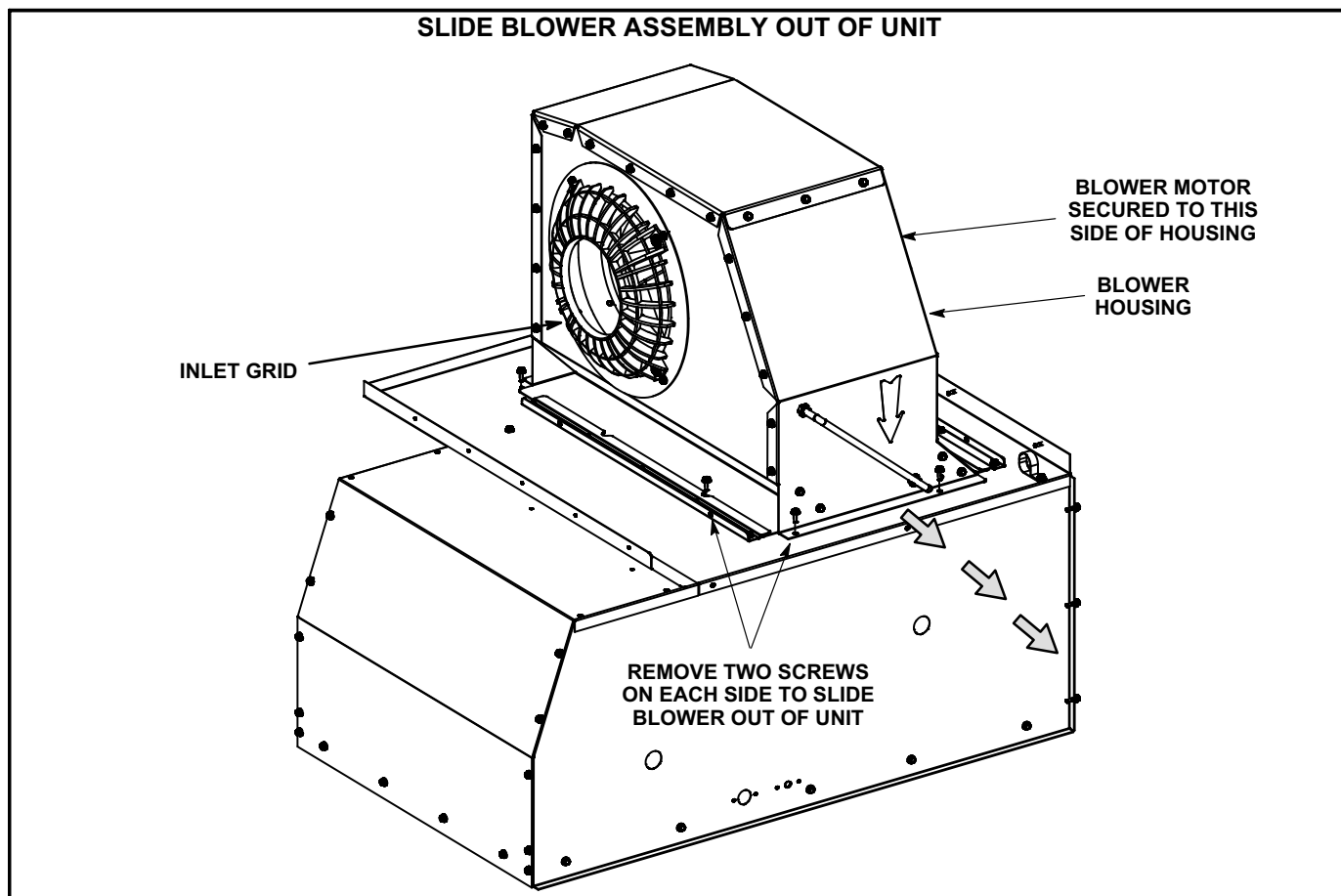

FIGURE 3

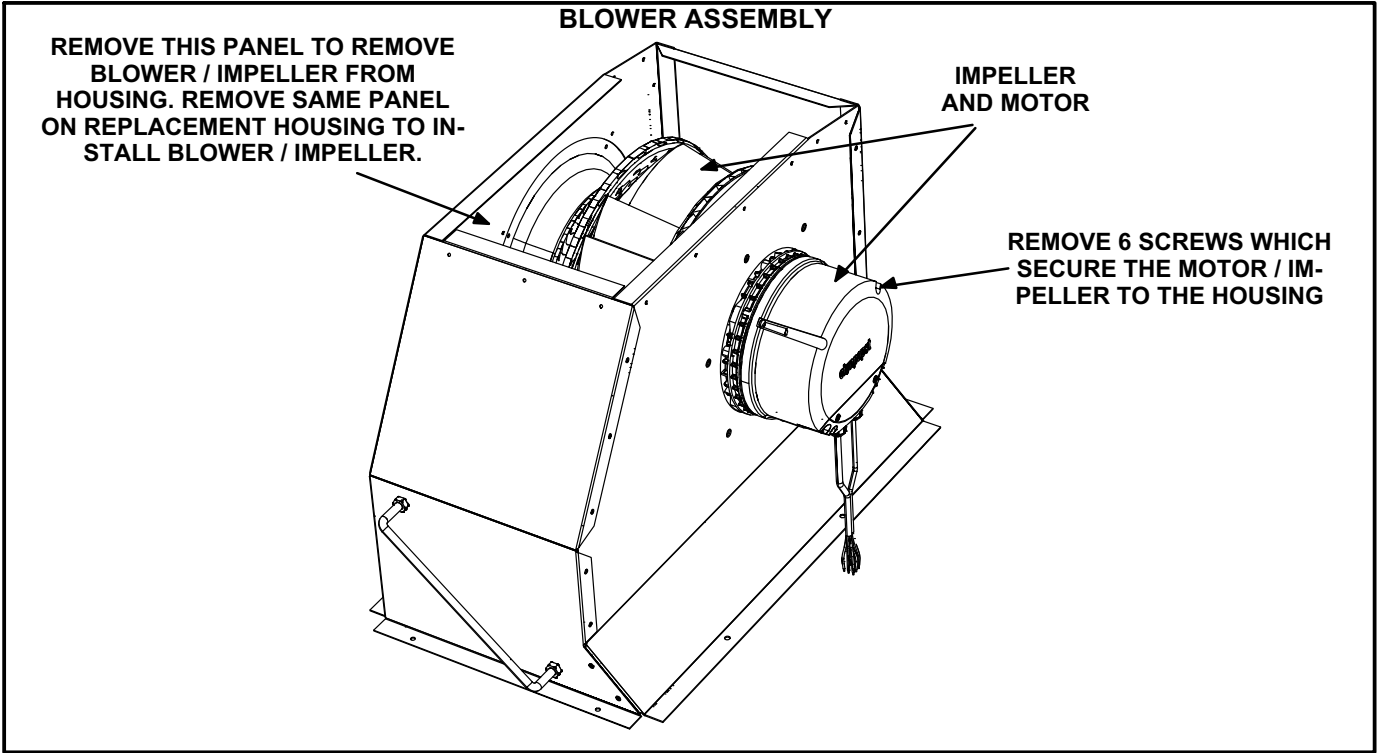

FIGURE 4

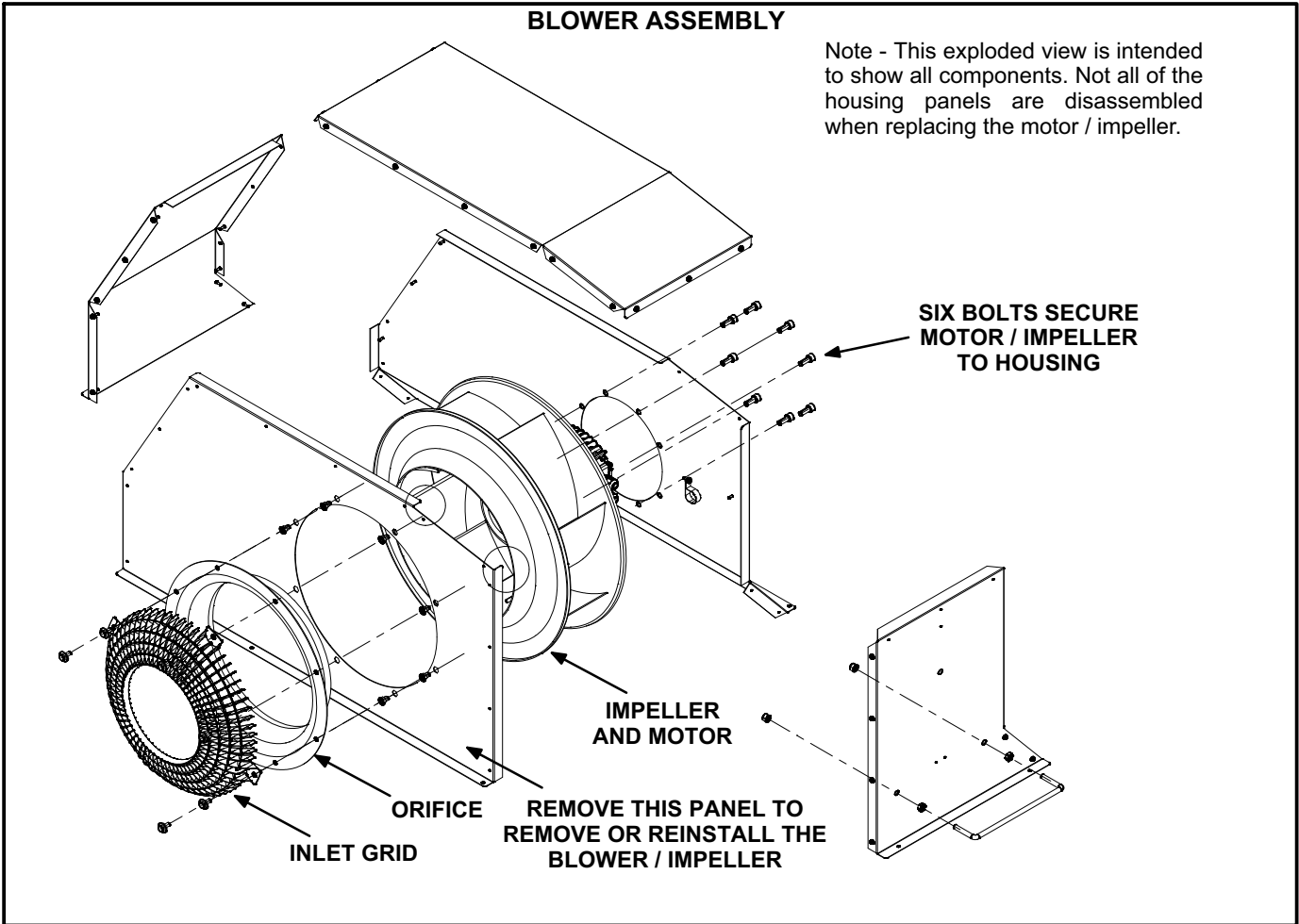

FIGURE 5