



©2021

GAS UNITS KITS & ACCESSORIES

508014-03
07/2021
Supersedes 508014-02

GAS CHANGEOVER KIT

INSTALLATION INSTRUCTIONS FOR NATURAL TO REGULATED LP/PROPANE GAS CHANGEOVER KIT (20P40 & 20P41) USED WITH EL180NE & SL280NV 80% EFFICIENCY ULTRA LOW NOX UNITS

⚠ WARNING

This conversion kit is to be installed by a licensed professional service technician (or equivalent) or other qualified agency in accordance with the manufacturer's instructions, all codes and requirements of the authority having jurisdiction in the USA. If the information in these instructions is not followed exactly, a fire or explosion may result causing property damage, personal injury or loss of life. The qualified agency performing this work assumes responsibility for this conversion.

⚠ CAUTION

As with any mechanical equipment, contact with sharp sheet metal edges can result in personal injury. Take care while handling this equipment and wear gloves and protective clothing.

Shipping and Packing List

Package 1 of 1 contains:

- 1 - Main gas orifice
- 1 - Gas converter sticker
- 1 - Nameplate conversion sticker
- 1 - Low gas inlet pressure switch (S145)
- 1 - Gas valve fitting
- 1 - Wire harness
- 1 - Air orifice
- 1 - 350°F high temperature limit (EL180UH080NE48B)
- 1 - 250°F high temperature limit (SL280UH080NV48B)

Application

Use natural to LP/Propane gas conversion kit 20P40 and 20P41 to convert EL180NE and SL280NV units from natural gas to regulated LP/propane gas. These kits are applicable for the -060 and -080 capacity units only.

TABLE 1

Unit Capacity	Gas Orifice	Air Orifice	Kit Number
-060	0.0469	0.906	20P40
-080	0.0550	1.062	20P41

Installation Figure 1

⚠ WARNING

Danger of explosion.

There are circumstances in which odorant used with LP/propane gas can lose its scent. In case of a leak, LP/propane gas will settle close to the floor and may be difficult to smell. An LP/propane leak detector should be installed in all LP applications.

- 1 - Set the thermostat to the lowest setting. Shut off the gas supply to the furnace, then turn off the electrical power at the unit disconnect switch.
- 2 - Remove the access panel. Move the automatic gas valve switch to the OFF position.
- 3 - Disconnect the gas supply from the gas valve. Disconnect the two-wire plug at the gas valve.
- 4 - Remove the four screws that hold the gas-air elbow to the gas-air collector hot box.

Single-Stage-EL180UH080NE48B

- a - Remove high temperature limit from the middle of the vestibule panel.
- b - Install 350° high temperature limit in the middle of the vest panel. See figure 2.

NOTE - The 250° limit is not needed.

Two-Stage-SL280UH080NV48B

- a - Remove high temperature limit from the middle of the vestibule panel.
- b - Install 250° high temperature limit in the middle of the vest panel. See figure 2.

NOTE - The 350° limit is not needed.

- 5 - Loosen the clamp attaching the intake to the gas-air elbow. Remove the intake from the gas-air elbow.
- 6 - Use a socket wrench to remove the gas orifice from inside of the manifold pipe. Replace with provided gas orifice. DO NOT USE sealant on orifice.



- 7 - Install the provided LP air orifice. Re-attach the intake to the gas-air elbow and tighten the clamp. Re-install the gas-air elbow to the collector box.
- 8 - Thread provided fitting to gas valve inlet until hand tight. Using properly sized wrench, tighten fitting 2 to 3 full turns being careful to position the side port to allow clearance for the pressure switch and harness. See FIGURE 3 or 4.

NOTE - Never use channel lock pliers or a pipe wrench on the brass fitting.

NOTE - Some installations may require the pressure switch and fitting assembly to be positioned differently than shown in FIGURE 3 and 4.

- 9 - Thread the gas supply to the fitting until hand tight. A field provided coupling may be needed. See figure 4. Using properly sized wrench to support fitting, tighten supply line into fitting 2 to 3 full turns to achieve leak free joint.

NOTE - Do not over tighten. Maximum 3 full turns past hand tight for 1/2" NPT per ASME B1.20.1-2013

- 10 - Thread pressure switch (S145) to fitting 2 to 3 turns past hand tight, then wire as shown in FIGURE 5.
- 11 - Reconnect two-wire plug to the gas valve.
- 12 - Reconnect electrical power to the unit.
- 13 - Inspect all sides of assembly. Turn on gas supply. **Immediately check the entire fitting surface and assembly joints for gas leaks.**
- 14 - Mark the appropriate information then affix nameplate conversion sticker next to unit nameplate.
- 15 - Complete the information required on the gas converter sticker: date, name, and address. Affix sticker to the exterior of the unit in a visible area.
- 16 - Follow the steps given in the start-up and adjustment section.

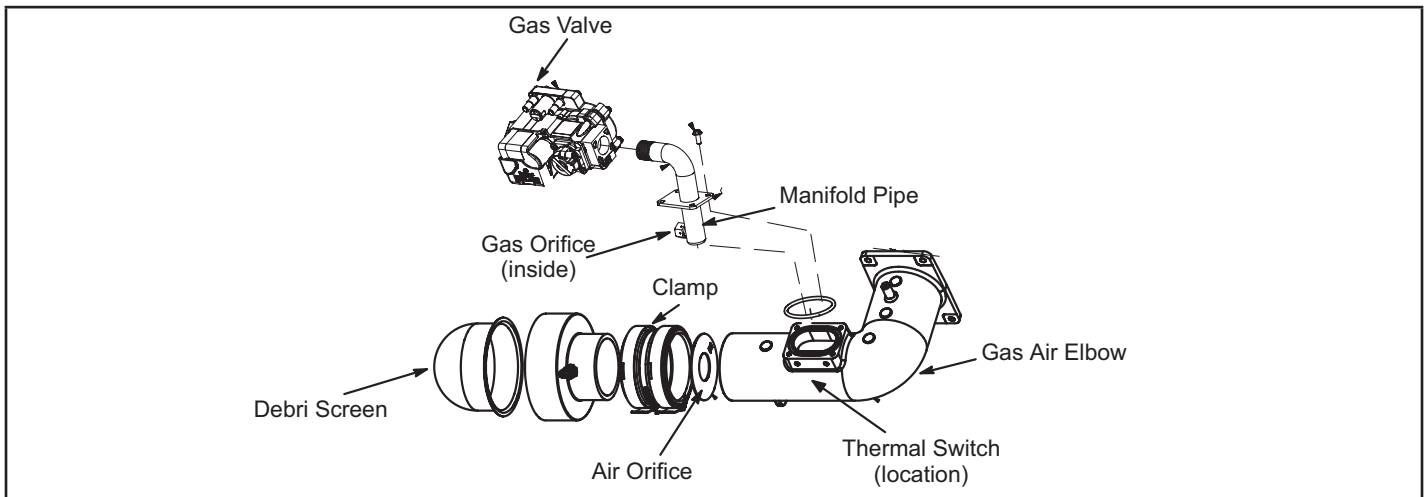

FIGURE 1

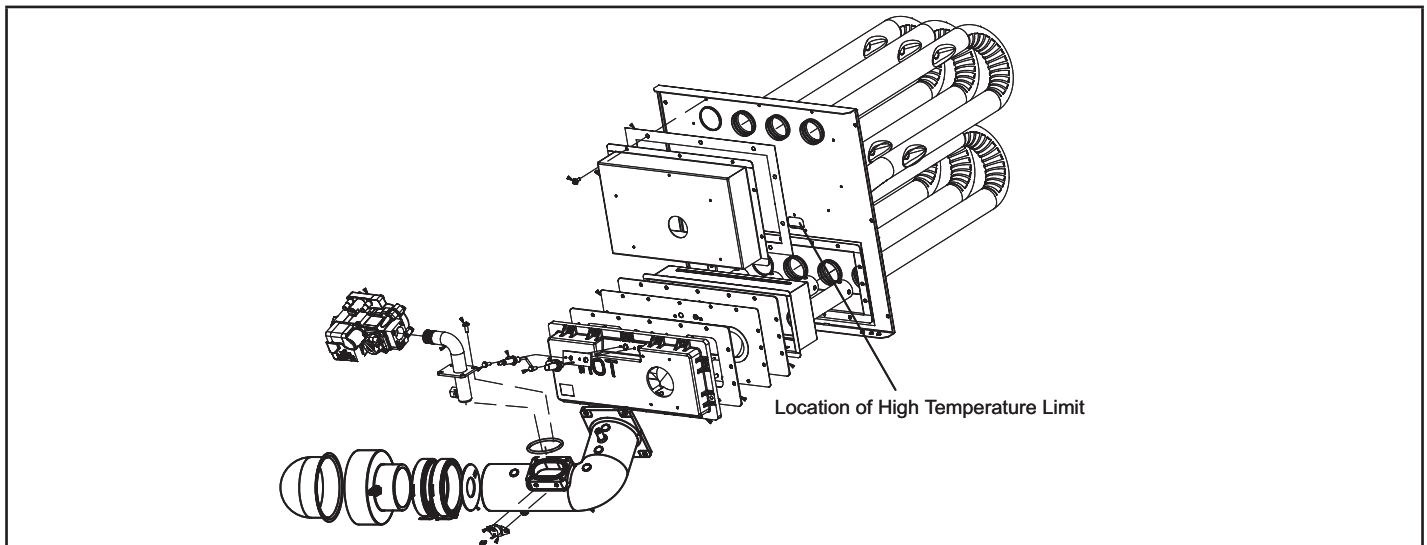

FIGURE 2

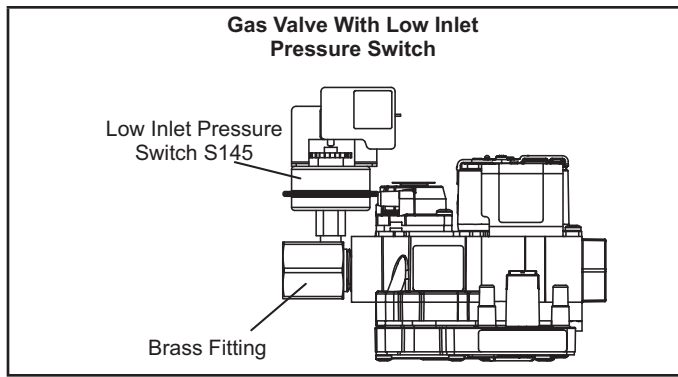

FIGURE 3

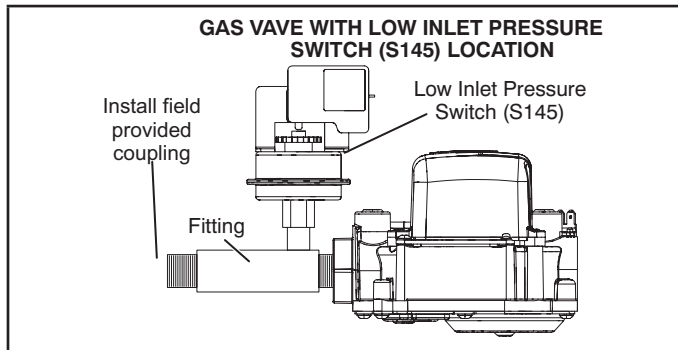

FIGURE 4

Start-Up & Adjustment

BEFORE PLACING THE UNIT INTO OPERATION -

Smell all around the appliance area for gas. Be sure to smell next to the floor because LP/Propane gas is heavier than air and will settle on the floor.

Use only your hand to move the gas control switch. Never use tools. If the switch will not move by hand, do not try to repair it. Force or attempted repair may result in a fire or explosion.

A - Placing the Unit into Operation

Follow the lighting instructions provided on the unit. If lighting instructions are not available, refer to the following section.

Units are equipped with an integrated ignition system. The integrated ignition control automatically lights the burners each time the thermostat calls for heat.

- 1 - **STOP!** Read the safety information at the beginning of this section.
- 2 - Set the thermostat to its lowest setting.
- 3 - Turn off all electrical power to the furnace.
- 4 - Do not try to light the burners by hand.
- 5 - Remove the unit access panel.
- 6 - Move the switch on the gas valve to OFF. Do not force the switch. See figure 6.
- 7 - Wait five (5) minutes for any gas to clear out. If you then smell gas, **STOP!** Immediately call your gas supplier from a neighbor's phone. Follow the gas supplier's instructions. If you do not smell gas, go to the next step.

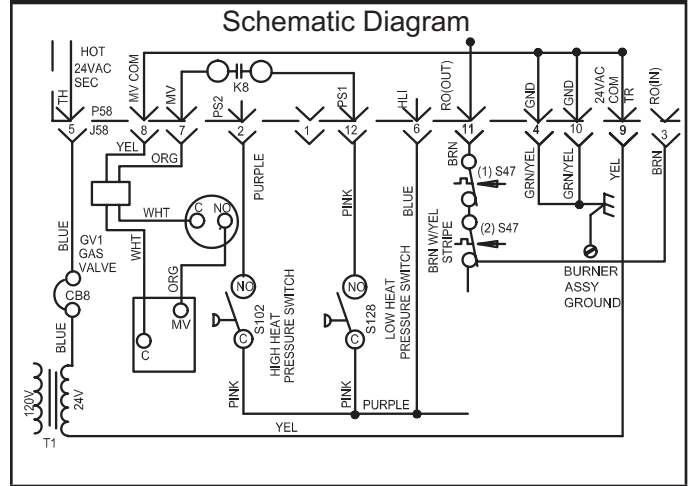
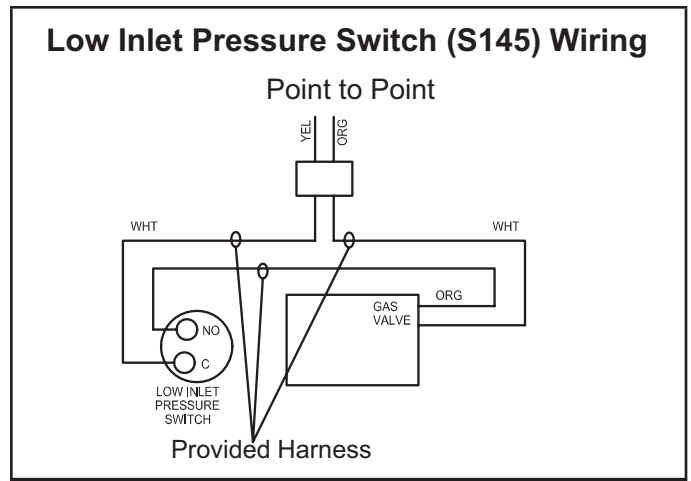

FIGURE 5

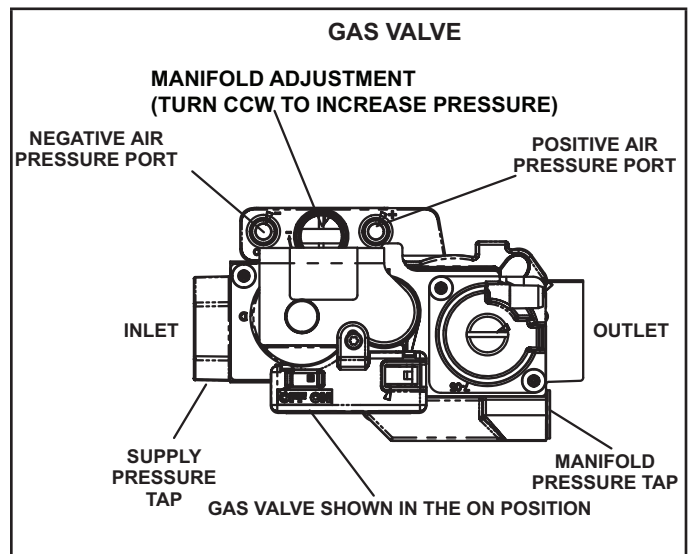

FIGURE 6

- 8 - Move the switch on the gas valve to ON.
- 9 - Replace the unit compartment access panel.
- 10 - Turn on all electrical power to the unit.
- 11 - Set the thermostat to desired setting.
- 12 - If the furnace will not operate, see section E- "Turning Gas Off to the Unit" and call the gas supplier.

Gas Pressure Measurement

A - Gas Flow (Approximate)

NOTE - To obtain accurate reading, shut off all other gas appliances connected to meter.

Furnace should operate at least 5 minutes before checking gas flow. Determine time in seconds for **two** revolutions of gas through the meter. (Two revolutions assures a more accurate time.) **Divide by two** and compare to time in table 2 below. If manifold pressure matches table 3 and rate is incorrect, check gas orifices for proper size and restriction. Remove temporary gas meter if installed.

TABLE 2

GAS METER CLOCKING CHART		
Unit Capacity	Seconds for One Revolution	
	1 cu ft Dial	2 cu ft Dial
-060	150	300
-080	112	224
2500 btu/cu ft		

B - Measuring Manifold Pressure

The gas valve is factory set and should not require adjustment. All gas valves are factory regulated. To correctly measure manifold pressure, follow the steps below:

- 1 - Remove the threaded plug from the outlet side of the gas valve and install a field-provided barbed fitting. Connect measuring device "+" connection to barbed fitting to measure manifold pressure.
- 2 - Start unit on low heat (two stage furnace) and allow 5 minutes for unit to reach steady state.
- 3 - After allowing unit to stabilize for 5 minutes, record manifold pressure and compare to value given in table 3 or table 4.
- 4 - Repeat on high heat (two stage furnace)
- 5 - Shut unit off and remove manometer as soon as an accurate reading has been obtained. Take care to remove barbed fitting and replace threaded plug.
- 6 - Start unit and perform leak check. Seal leaks if found.

C - Supply Pressure Measurement

A threaded plug on the inlet side of the gas valve provides access to the supply pressure tap. Remove the threaded plug, install a field-provided barbed fitting and connect a manometer to measure supply pressure. See table 3. Replace the threaded plug after measurements have been taken.

D- Proper Combustion

Furnace should operate minimum 15 minutes with correct manifold pressure and gas flow rate before checking combustion. Take combustion sample beyond the flue outlet. See table 5 for correct combustion. **The maximum carbon monoxide reading should not exceed 100 ppm.**

NOTE - Shut unit off and remove manometer as soon as supply line pressure, manifold pressure and combustion sample have been obtained. Take care to replace pressure tap plug.

TABLE 3
Two-Stage Furnace

Capacity	Manifold Pressure in.wg.		Supply Line Pressure in.wg.	
	Low Fire	High Fire	Min	Max
060/080	1.7	3.6	11.0	13.0

TABLE 4
Single-Stage Furnace

Capacity	Manifold Pressure in.wg.	Supply Line Pressure in.wg.
060/080	3.6	11.0 - 13.0

TABLE 5

Model	CO ₂ %	
	Low Fire	Hig Fire
SL280NV-060, -080	7.5 - 9.0	7.5 - 9.0
EL180NE-060, -080	7.5 - 9.0	

E - Turning Off Gas To the Unit

- 1 - Set the thermostat to its lowest setting.
- 2 - Turn off all the electrical power to the unit.
- 3 - Remove the unit access panel.
- 4 - Move the switch on the gas valve to **OFF**. Do not force the switch.