

⚠ WARNING

Improper installation, adjustment, alteration, service or maintenance can cause property damage, personal injury or loss of life. Installation and service must be performed by a licensed professional installer (or equivalent), service agency or the gas supplier.

⚠ CAUTION

As with any mechanical equipment, personal injury can result from contact with sharp sheet metal edges. Be careful when you handle this equipment.

INSTALLATION INSTRUCTIONS

LS25

30,000 to 400,000 Btuh Series

SEPARATED COMBUSTION UNIT HEATERS

508064-02

1/2022

Replaces 5/2021

Note - Unit heaters are designed for indoor use only.

Table Of Contents

Shipping and Packing List.....	2	Unit Start-Up	25
30/105 Compact Unit Dimensions.....	3	To Turn Off Gas to Unit	26
30/105 Compact Unit Parts Arrangement.....	4	Heating Sequence of Operations	26
125/200 Unit Dimensions Single Fan	5	Ignition Control LED	27
250/400 Unit Dimensions Dual Fan.....	6	High Altitude Adjustments	27
Unit Parts Arrangement	7	Gas Flow	27
Optional Accessory.....	8	Supply Gas Pressure Adjustments	27
Requirements in USA.....	8	Supply Pressure Measurement	27
Requirements in Canada.....	8	Manifold Pressure Measurement.....	28
Additional Requirements	9	Limit Control Switch.....	28
Unit Heater Installation	9	Louver Vane Adjustment	28
Combustion and Ventilation Air.....	13	Combustion Air Pressure Switch	28
Venting.....	13	Flame Roll-out Switch	28
Electrical Connections	19	Service.....	28
Gas Connection	24	Start-Up and Performance Checklist	28
Leak Check	25		

RETAIN THESE INSTRUCTIONS FOR FUTURE REFERENCE





⚠ WARNING

FIRE OR EXPLOSION HAZARD.

Failure to follow safety warnings exactly could result in serious injury, death, or property damage.



Be sure to read and understand the installation, operation and service instructions in this manual.

Improper installation, adjustment, alteration, service or maintenance can cause serious injury, death or property damage.

Do not store or use gasoline or other flammable vapors and liquids in the vicinity of this or any other appliance.

Installation and service must be performed by a qualified installer, service agency or the gas supplier.

WHAT TO DO IF YOU SMELL GAS:

- Do not try to light any appliance.
- Do not touch any electrical switch; do not use any phone in your building.
- Leave the building immediately.
- Immediately call your gas supplier from a neighbor's phone. Follow the gas supplier's instructions.
- If you cannot reach your gas supplier, call the fire department.

Shipping and Packing List

30-105 Units

Package 1 of 1 contains:

- 1-Unit Heater
- 2-Hanging brackets
(4" Flue transition is factory-installed)
- Bag assembly containing:
 - 1-Warranty card
 - 1-Brand logo badge
 - 8-#10-16 X 5/8" SDST screws
 - 1-3/8" Snap bushing
 - 3-Wire ties

The heater is shipped completely assembled. Check the unit for shipping damage. The receiving party should contact the last carrier immediately if any shipping damage is found.

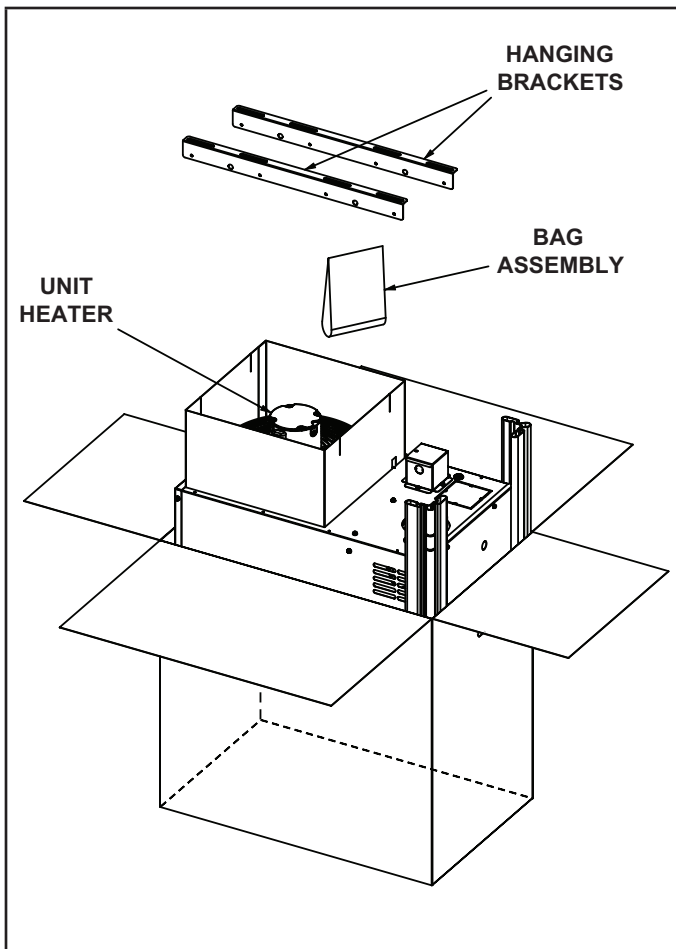

Shipping and Packing List

125-400 Units

Package 1 of 1 contains:

- 1-Unit Heater
- 1-Combustion air box (shipped between combustion air blower and fan motors)
- 1-Rectangular to round flue transition
 - 5" diameter on 125-300 (provided and field-installed)
 - 6" diameter on 350-400 (provided and field-installed)
- Bag assembly containing:
 - 1-Warranty card
 - 1-Brand logo badge
 - 8-#10-16 X 5/8" SDST screws
 - 2-Wire ties

The heater is shipped completely assembled. Check the unit for shipping damage. The receiving party should contact the last carrier immediately if any shipping damage is found.

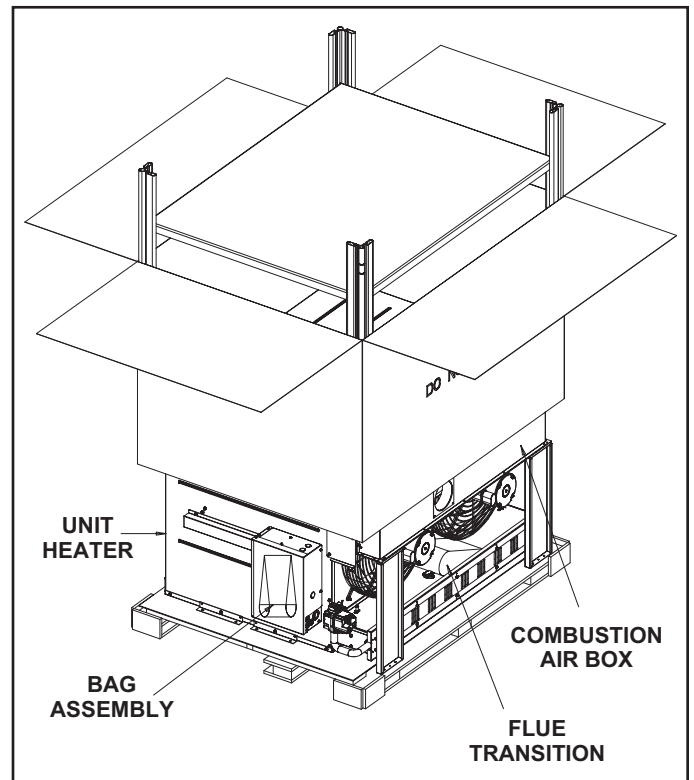

LS25-030 / 105 DIMENSIONS - Inches (mm)

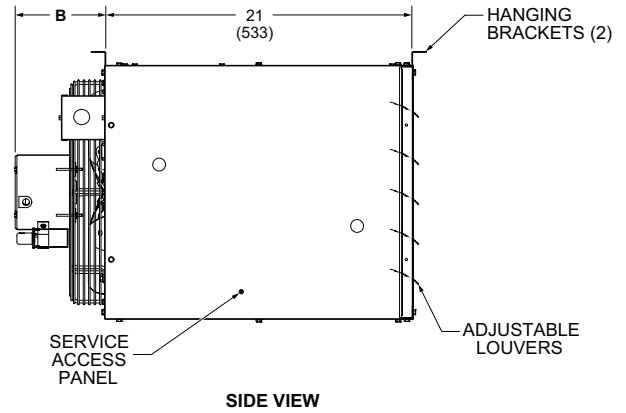
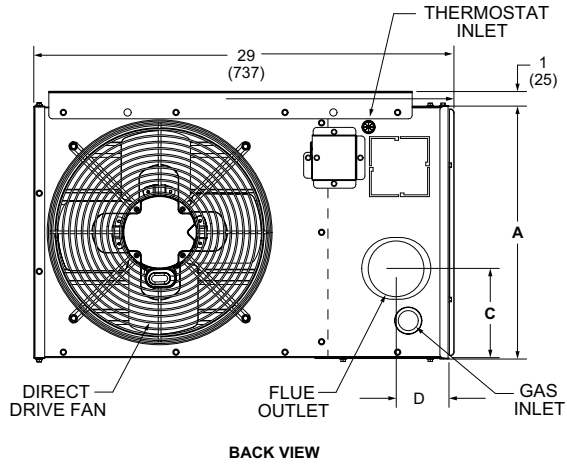
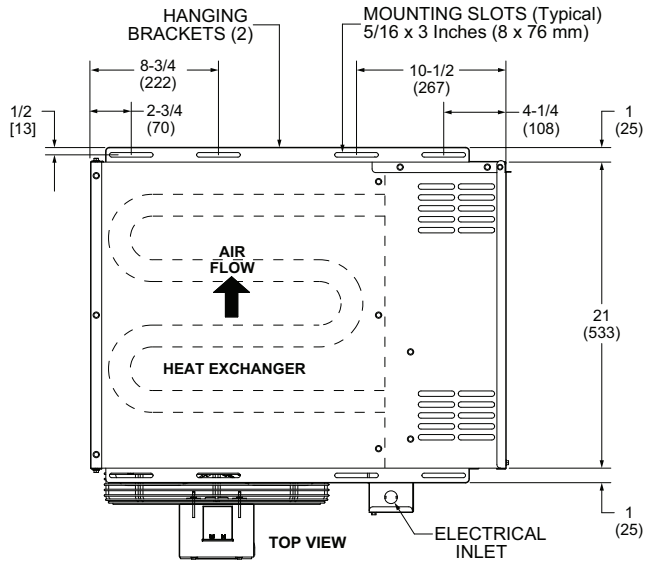

Model No.	A		B		C		D	
	in.	mm	in.	mm	in.	mm	in.	mm
LS25-030A LS25-045A	12-3/8	314	6-1/2	165	4	102	6	152
LS25-060A LS25-075A	17-1/2	445	6-1/4	159	6-1/8	156	3-5/8	92
LS25-090A LS25-105A	23	584	7-7/8	200	9-1/8	232	3-5/8	92

PARTS ARRANGEMENT 030K THRU 105K BTUH

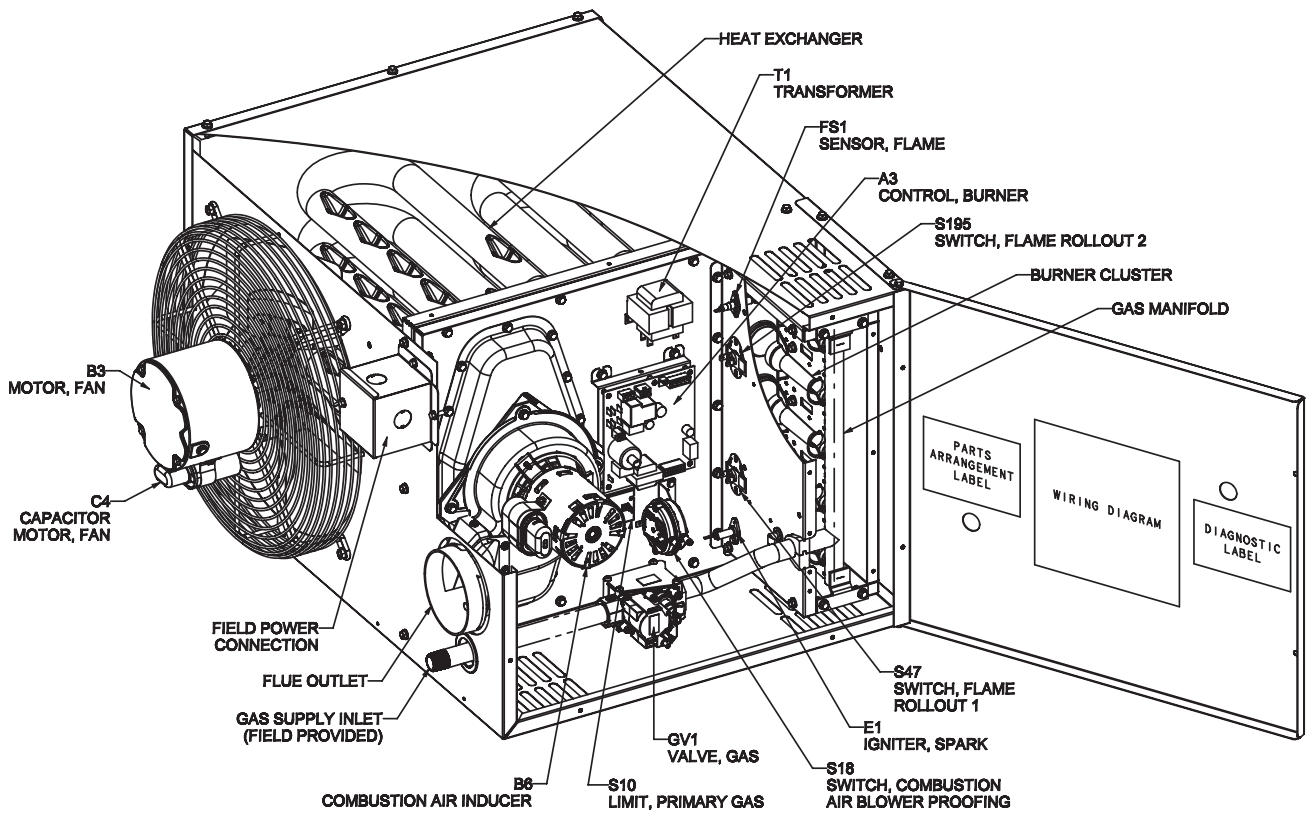

**LS25-125-150-175-200 (SINGLE FAN)
DIMENSIONS - Inches (mm)**

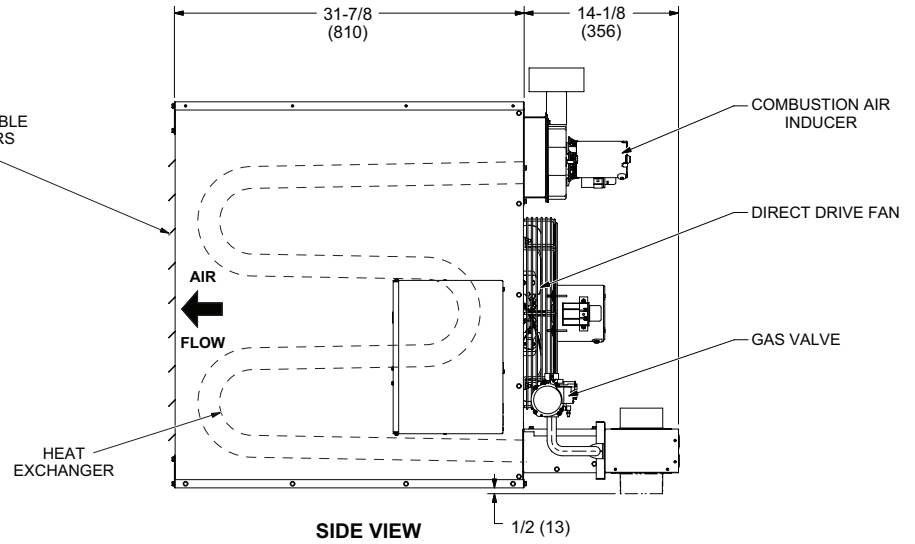
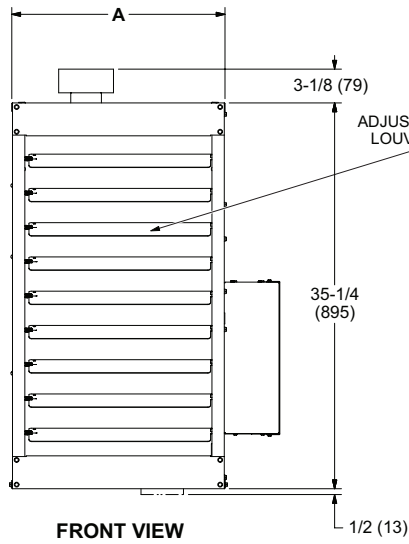
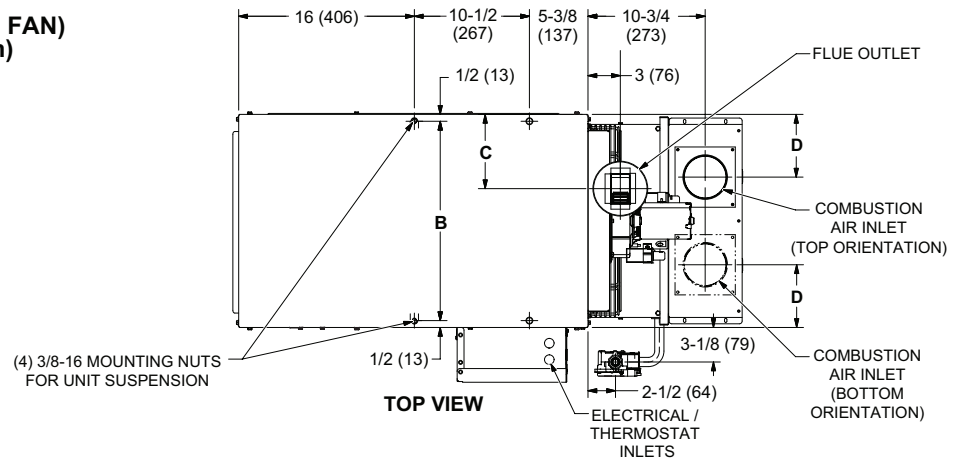

Model No.	A		B		C		D	
	in.	mm	in.	mm	in.	mm	in.	mm
LS25-125 LS25-150	19-1/2	495	18-1/2	470	6-3/4	171	5-3/4	146
LS25-175 LS25-200	25	635	23-3/4	603	9-1/2	241	6-1/8	156

**LS25-250-300-350-400 (DUAL FANS)
DIMENSIONS - Inches (mm)**

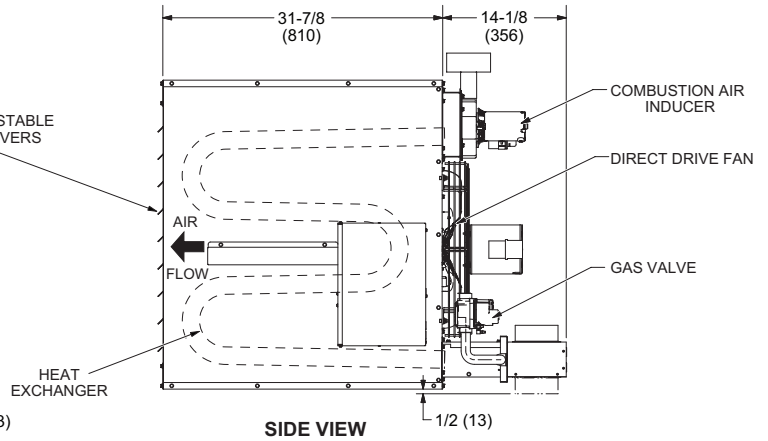
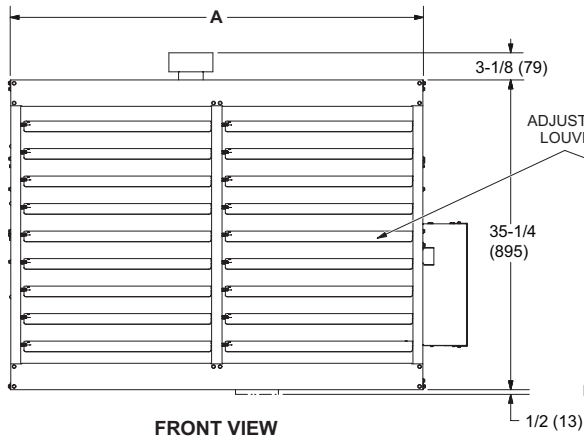
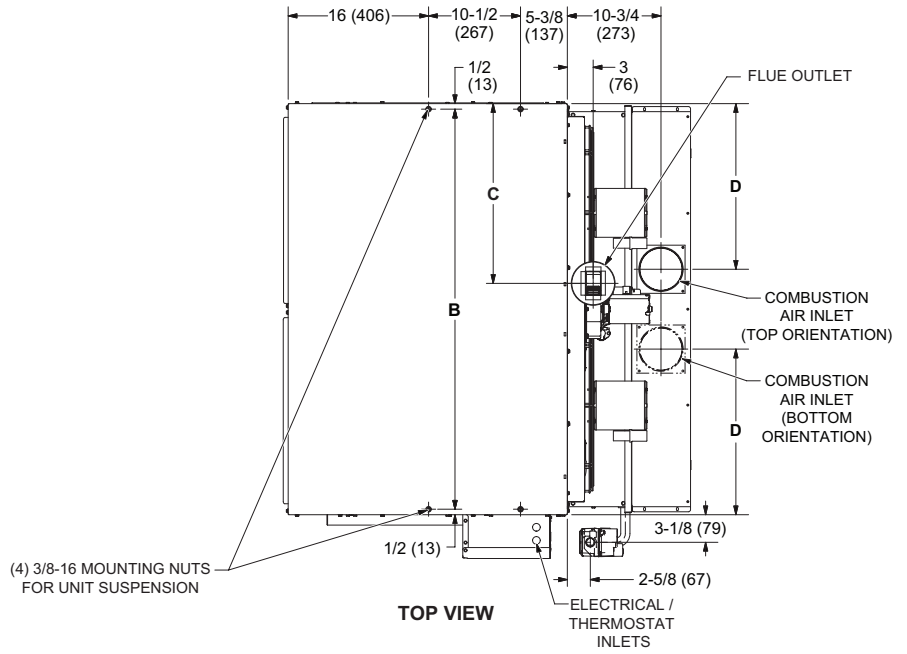

Model No.	A		B		C		D	
	in.	mm	in.	mm	in.	mm	in.	mm
LS25-250 LS25-300	37-5/8	956	36-1/2	927	15-7/8	403	12-1/2	318
LS25-350 LS25-400	47	1194	45-3/4	1162	20-1/2	521	18-7/8	479

**PARTS ARRANGEMENT
125K THRU 400K BTUH**

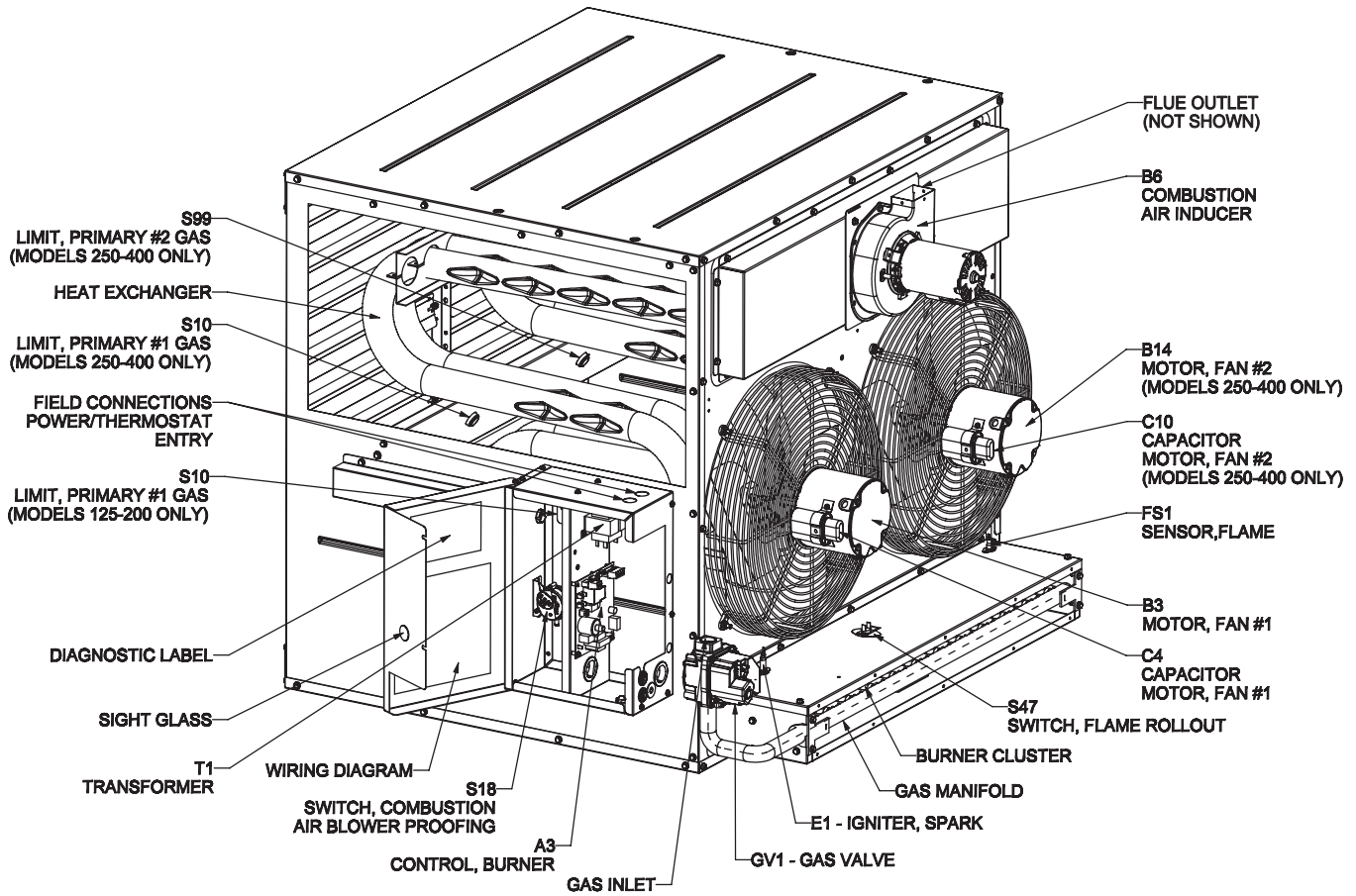

Optional Accessory

Units require a conversion kit when the unit is to be used with LP/propane gas. The kit is ordered separately. See Engineering Handbook.

Requirements in USA

Installation of gas unit heaters must conform with local building codes or, in the absence of local codes, with the current edition of ANSI Z223.1, National Fuel Gas Code. Installation in aircraft hangers must be in accordance with the current edition of ANSI/NFPA No. 409, Standard for Aircraft Hangers.

Installation in parking structures must be in accordance with the current edition of ANSI/NFPA No. 88A, Standard for Parking Structures.

Installation in repair garages must be in accordance with the current edition of ANSI/NFPA No. 88B, Standard for Repair Garages.

These units are approved for residential garage or non-confined living space applications. For installation in a residential garage or non-confined living space, unit must be installed so that burners and ignition source are located no less than 18" (457mm) above floor. Heater must be located or protected to avoid physical damage by vehicles. Refer to the current edition of ANSI Z223.1, National Fuel Gas Code.

Authorities having jurisdiction should be consulted before installation. Air for combustion and ventilation must conform to the methods outlined in the current edition of ANSI Z223.1, Section 5.3, Air for Combustion and Ventilation, or applicable provisions of local building codes.

The National Fuel Gas Code (ANSI Z223.1) is available from:

American National Standard Institute Inc.

11 West 42nd Street

New York, NY 10036

These unit heaters are CSA International design-certified. These unit heaters are certified for installation to combustible material as listed in table 1 and on unit rating plate.

Accessibility and service clearances must be observed in addition to fire protection clearances.

All electrical wiring and grounding for unit must be in accordance with the regulations of the current edition of ANSI/NFPA No. 70, National Electric Code.

The National Electric Code is available from:

National Fire Protection Association

1 Batterymarch Park

PO Box 9101

Quincy, MA 02269-9101

Requirements in Canada

These instructions are intended only as a general guide and do not supersede local codes in any way. Authorities having jurisdiction should be consulted before installation. The installation must conform with local building codes or, in the absence of local codes, with the current edition of CSA-B149 installation compliance codes. All electrical wiring and grounding for the unit must also comply with the current edition of CSA C22.1, Canadian Electrical Code. These unit heaters are CSA-certified for the installation clearances listed on the rating plate and in table 1.

Adequate clearance must be provided around the appliance and around air openings into the combustion chamber. Provision shall be made for service accessibility.

NOTE - Fire protection clearances may be exceeded to provide additional space for service and accessibility.

GARAGE / WAREHOUSE INSTALLATIONS

- 1 - In a storage area, clearance from heaters to combustible materials must be such that the combustible material must not attain a temperature above 160°F (71°C) by continuous operation of the unit.

WARNING

Combustible materials that are affected by exposure to temperatures LESS than 160°F or 71°C (plastics, plastic wrap, styrofoam, cardboard, etc.) must be stored well away from this heater. Discharge air temperatures for these units can approach 250°F or 121°C.

- 2 - Maintain an 8-foot (2m) minimum clearance from the floor to the bottom of the heater. Refer to the current edition of CSA-B149 for installation compliance codes.

AIRCRAFT HANGER

- 1 - In an area where aircraft are housed or serviced, a 10-foot (3m) minimum clearance from the highest surface of the aircraft to bottom of the heater must be maintained.
- 2 - In other areas, an 8-foot (2m) minimum clearance from the floor to bottom of heater must be maintained.
- 3 - Heaters should be located so that they are protected from damage from aircraft or other appliances needed for servicing of aircraft. Refer to requirements of the enforcing authorities.

RESIDENTIAL

These units are approved for residential garage or non-confined living space applications. For installation in a residential garage or non-confined living space, unit must be installed so that burners and ignition source are located no less than 18" (457mm) above floor. Heater must be located or protected to avoid physical damage by vehicles. Refer to the current edition of CSA-B149 for installation compliance codes. In a confined area, the heater must be installed in accordance with the current edition of CSA-B149 installation compliance codes. Be sure to check with local codes and ordinances for additional requirements.

TABLE 1

UNIT CLEARANCES TO COMBUSTIBLE MATERIALS

Unit	Top		Side**		Bottom		Back		Flue	
	in	mm	in	mm	in	mm	in	mm	in	mm
030/105	1	25	1	25	1	25	18	457	6*	152
125/400	6	152	18	457	1	25	18	457	6	152

*6" is for single wall. Double wall B-vent clearance will be in accordance with the manufacturer's listing.

**Access panel or control box side of unit should have 24" (610mm) clearance.

Additional Requirements

The Commonwealth of Massachusetts stipulates the following additional requirements:

- 1 - Gas furnaces shall be installed by a licensed plumber or gas fitter only.
- 2 - The gas cock must be "T handle" type.

Unit Heater Installation

LS25-125/400

The appliance shall not be installed downstream from evaporator coils or cooling units.

Install the unit in the desired location as governed by clearances, vent connection, air direction, gas supply, electrical supply and service accessibility.

Unit is shipped ready for installation.

⚠ CAUTION

Do not install unit heaters in close proximity to fire sprinklers. Unit heater normal operating temperatures could result in fire sprinkler activation.

Four mounting nuts are furnished. Refer to dimension illustration. Mounting nuts will accommodate 3/8" x 16 threaded rods.

- 1 - Push each louver to the left to depress spring and release locking tab on the other end (locking tab keeps the louver in place for shipping).
- 2 - Rotate louvers to direct airflow as desired.
- 3- Cut threaded rods to desired length and slide a 3/8" nut onto the rod.

TABLE 2

MAXIMUM MOUNTING HEIGHTS

Unit	Feet (Meters)
030/075	10 (3.0)
090/105	12 (3.7)
125/150	16 (4.9)
175/200	20 (6.1)
250/400	30 (9.1)

- 4 - Slide a flat washer onto the threaded rod AFTER the nut (7/16" inside diameter X 1" outside diameter X 1/16" thick washer).
- 5 - Screw the rods (four) into the mounting nuts on the unit. See figure 1.
- 6 - Tighten nuts to secure unit to rods.
- 7 - Install the 3D brand badge provided with the unit.
- 8 - Remove and discard the shipping brackets. Replace four screws on each side as shown in figure 2.
- 9 - Install the combustion air intake box. See figure 3 for top entry and figure 4 for bottom entry.
- 10-Install the flue transition, provided with the unit, onto the combustion air blower flue outlet. If needed, loosen the upper right two or three screws securing the combustion air blower. Slide the transition into place and secure loosened screws.

NOTE - The combustion air intake connector is shipped with the flange facing the inside of the combustion air intake box. Remove and reinstall connector with the flange facing the outside of the combustion air box (in a position to accept the field-provided air intake pipe).

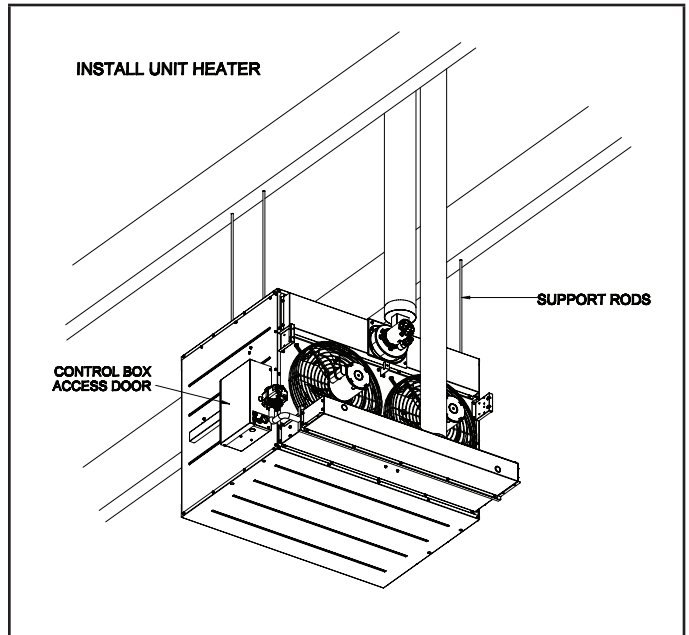

FIGURE 1

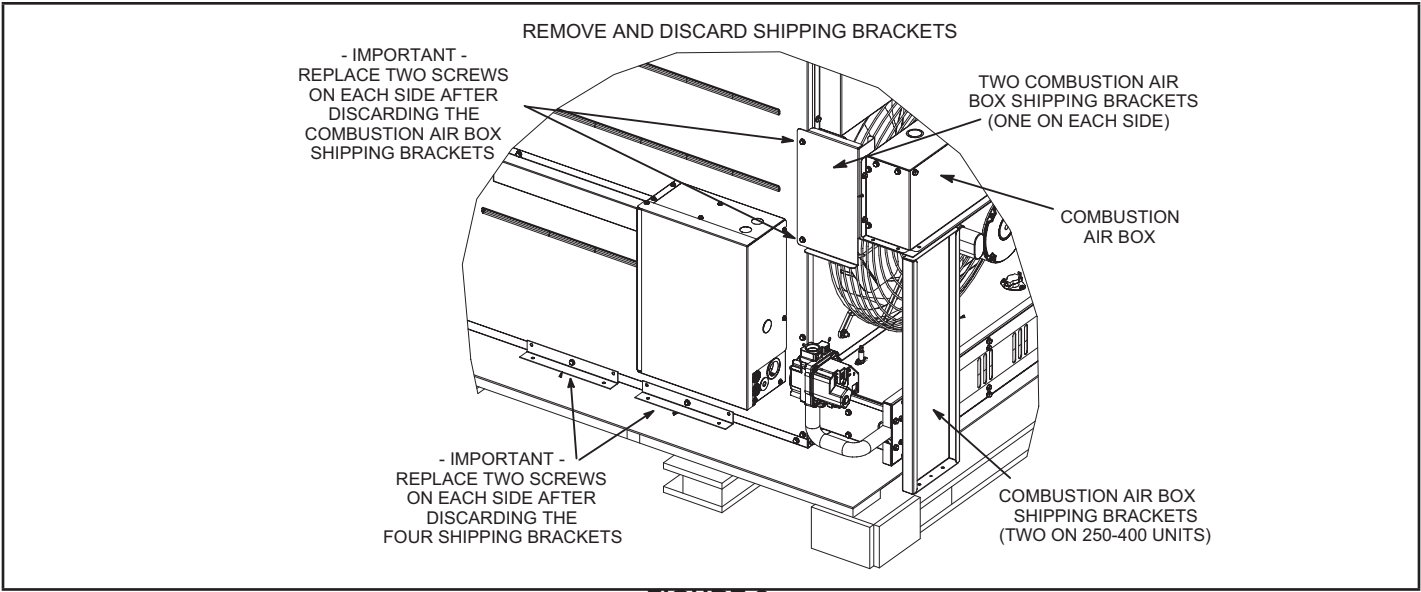

FIGURE 2

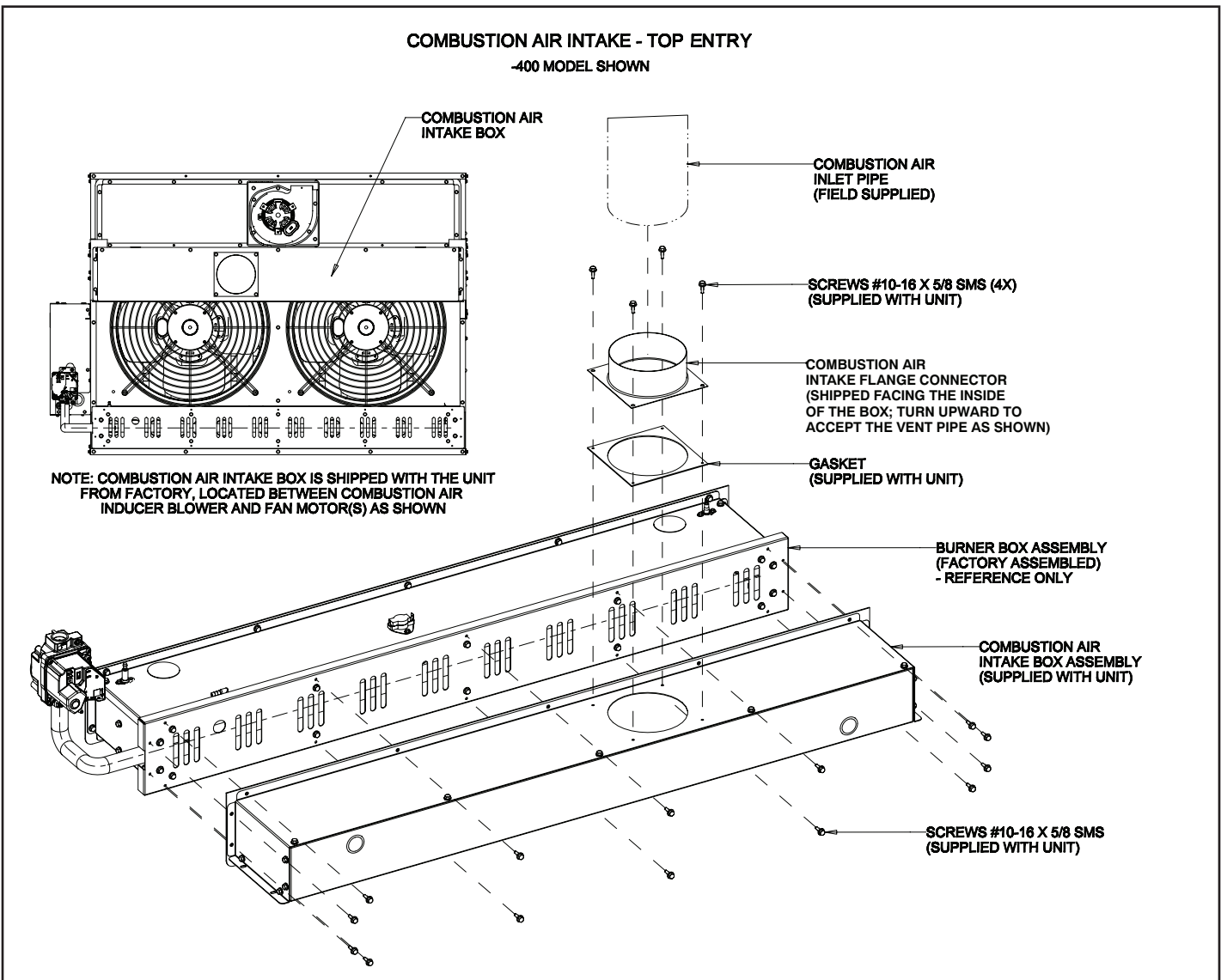

FIGURE 3

COMBUSTION AIR INTAKE - BOTTOM ENTRY
-400 MODEL SHOWN

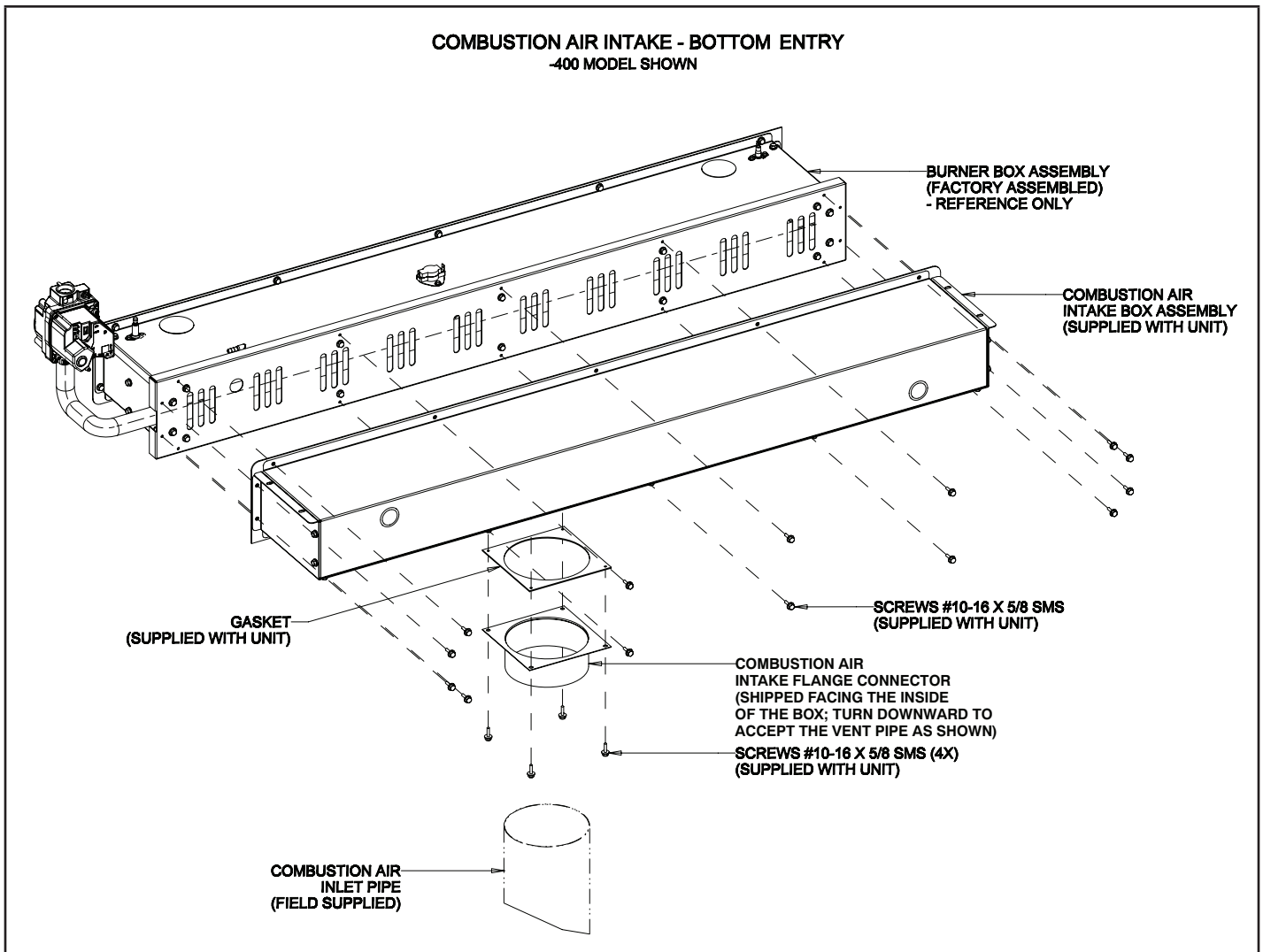

FIGURE 4

LS25-030/105

Unit may be installed as shown in figure 5 or rotated 180°.

- 1 - Push each louver to the right to depress spring and release locking tab on the other end (locking tab keeps the louver in place for shipping).
- 2 - If installing unit in a rotated position - release locking tabs in the same manner as previous step. Rotate each louver 180° and reinstall. Remove and retain screws securing access panel. Rotate access panel 180° and re-secure using retained screws.
- 3 - Rotate louvers to direct airflow as desired.
- 4 - Choose location for mounting brackets.
- 5 - Align mounting brackets with pilot holes on the top or bottom (when rotating) edge of the unit. Secure with screws provided in bag assembly.
- 6 - To support unit, secure mounting bracket to ceiling joist or truss. Unit may also be supported using support rods as shown in figure 5.
- 7 - Install the 3D brand badge provided with the unit.
- 8 - Remove the combustion air piping access cutout. See figure 6.

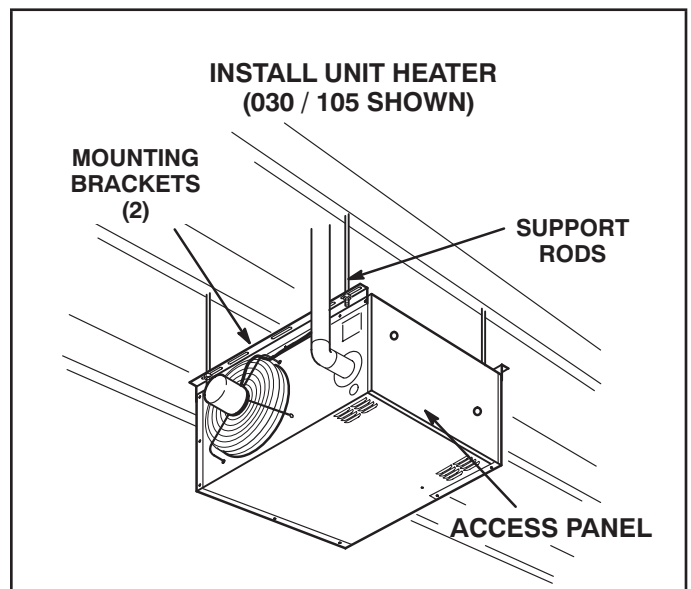

FIGURE 5

- 9 - Insert the combustion air inlet pipe through the access cutout.
- 10 - Connect the pipe to the combustion air intake flange connector

COMBUSTION AIR INTAKE PIPING -075 MODEL SHOWN

** LENNOX RECOMMENDS USING A SHORT PIECE OF PIPE TO CONNECT BETWEEN THE UNIT AND COMBUSTION AIR FIELD-PIPING FOR EASE OF SERVICE. INSTALL THE COMBUSTION AIR PIPE AFTER THE UNIT WIRING IS COMPLETE.

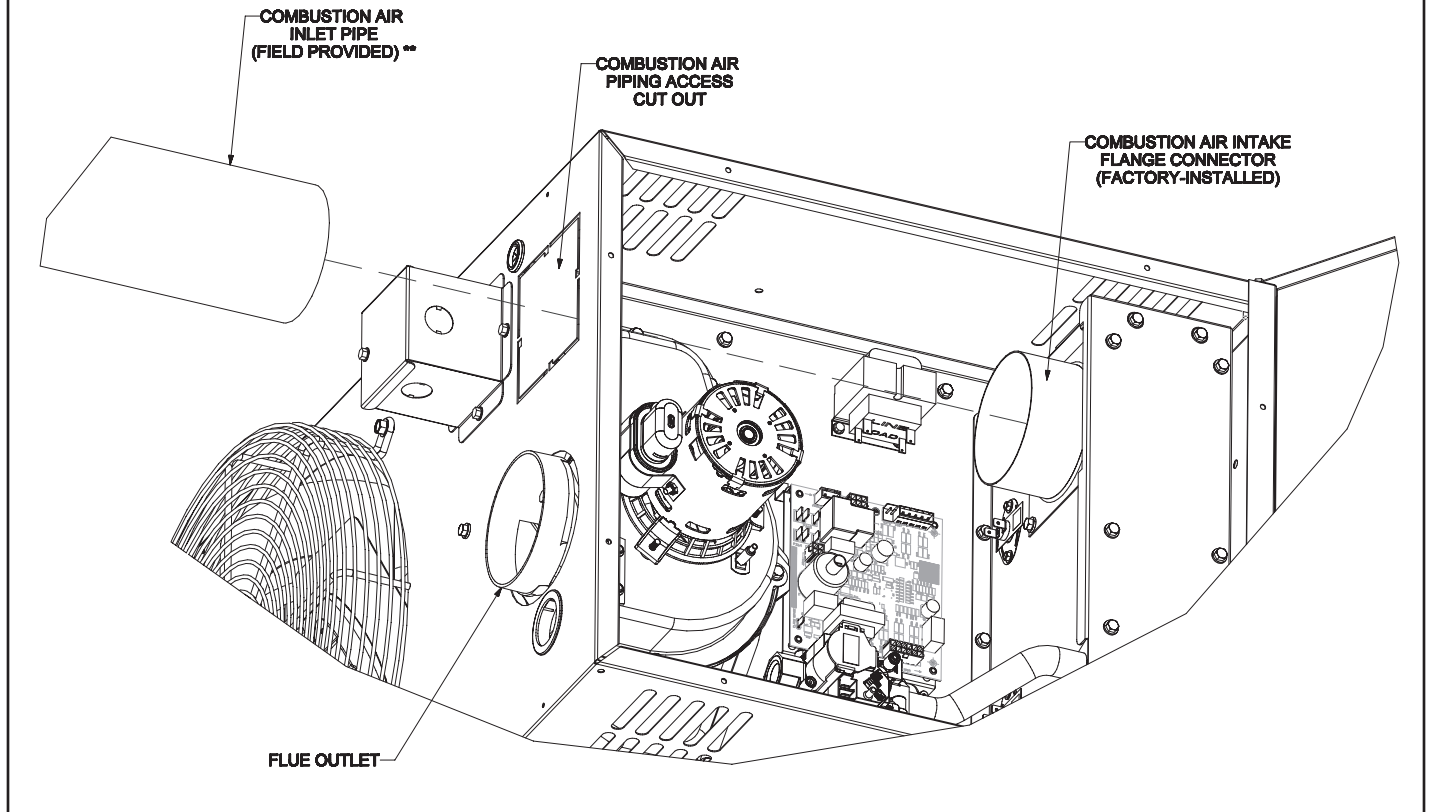

FIGURE 6

Combustion and Ventilation Air

Adequate facilities for supplying air for combustion and ventilation must be provided in accordance with the current edition of ANSI Z223.1, section 5.3 and CSA-B149 installation compliance codes, or applicable provisions of local building codes.

All gas-fired appliances require air to be used for combustion. In many buildings today, there is a negative indoor air pressure caused by exhaust fans, etc. If sufficient quantities of combustion air are not available, the heater or another appliance will operate in an inefficient manner, resulting in incomplete combustion which can result in the production of excessive carbon monoxide.

WARNING

Insufficient combustion air can cause headaches, nausea, dizziness or asphyxiation. It will also cause excess water in the heat exchanger resulting in rusting and premature heat exchanger failure. Excessive exposure to contaminated combustion air will result in safety and performance related problems. Avoid exposure to the following substances in the combustion air supply:

- Permanent wave solutions
- Chlorinated waxes and cleaners
- Chlorine base swimming pool chemicals
- Water softening chemicals
- De-icing salts or chemicals
- Carbon tetrachloride
- Halogen type refrigerants
- Cleaning solvents (such as perchloroethylene)
- Printing inks, paint removers, varnishes, etc.
- Hydrochloric acid
- Cements and glues
- Antistatic fabric softeners for clothes dryers
- Masonry acid washing materials

This unit must be provided with a combustion air pipe that is connected to the outside atmosphere. Outdoor air must be free of the following substances or the life of the heat exchanger will be adversely affected: chlorine, carbon tetrachloride, cleaning solvent, halogen refrigerants, acids, cements and glues, printing inks, fluorides, paint removers, varnishes, or any other corrosives.

Venting

NOTE - The gas vent is a passageway, vertical or nearly so, used to convey flue gases from an appliance, or its vent connector, to the outside atmosphere. The vent connector is the pipe or duct that connects a fuel-gas-burning appliance to a gas vent or chimney.

NOTE - Local codes may supersede any of these provisions.

GENERAL RECOMMENDATIONS AND REQUIREMENTS

Unit heaters must be vented in compliance with the latest edition of the National Fuel Gas Code (NFPA 54 / ANSI Z223.1) in the USA and with CSA-B149.1 codes in Canada, as well as applicable provisions of local building codes, and the following instructions.

030-105 Units - A flue transition is factory-installed on the combustion air blower flue outlet.

125-400 Units - A sheet metal transition is supplied with this certified unit. It must not be modified or altered and must be installed on the flue outlet of the combustion air inducer assembly before installing the vent connector. Failure to comply with this requirement will void the certification of the unit by the approval agencies.

Combustion Air Connector - The factory provided combustion air inlet connector shall be used without modification or alteration.

For Residential and Commercial applications, metal vent pipe is recommended for use as the Combustion Air Pipe whether vented horizontally or vertically.

Use manufacturer specified gas vent sizes for Combustion Air Inlet and Flue Outlet for each model (refer to table 3).

Concentric venting is not approved for use in either vertical or horizontal vent applications.

Note - Different manufacturers have different joint systems and adhesives. Do not mix pipe, fittings or joining methods from different manufacturers.

A single-wall metal vent pipe used as a vent connector in residential or commercial applications, or as a vertical gas vent in commercial applications, must have all seams and joints sealed with pressure-sensitive aluminum tape or silicone rubber sealant. The aluminum tape must have a temperature rating of at least 400°F (204°C), i.e., 3M 433 or equivalent. Silicone rubber sealant must have a temperature rating of 482°F (250°C), i.e., Dow Corning RTV-736 or equivalent. All joints must be secured with at least two corrosion-resistant screws. All joints must be checked for gas tightness after installation.

VERTICAL VENTS - COMMERCIAL AND RESIDENTIAL INSTALLATIONS

These unit heaters are listed as Category 1 appliances for vertical gas vent installations.

- 1 - These unit heaters are to be used with NFPA- or ANSI-approved chimneys or U.L.-listed type B-1 gas vents, or listed chimney lining systems for gas venting where applicable, as well as the modifications and limitations listed in figure 7 or 8. Seal single-wall metal pipe according to **General Recommendations and Requirements** section.
- 2 - A single-wall metal pipe may be used as a vent connector between the unit heater and the vertical gas vent in all applications; however, **single-wall metal pipe cannot be used for vertical gas vent in residential applications.**
- 3 - Keep the vent connector runs as short as possible with a minimum number of elbows. Refer to the current edition of ANSI Z223.1 or CSA-B149 installation compliance codes for maximum vent and vent connector lengths.
- 4 - The entire length of a single-wall metal vent connector shall be readily accessible for inspection, cleaning and replacement.
- 5 - Single-wall metal pipe used as vertical gas vent in commercial applications must not pass through any attic, interior wall, concealed space, or floor.
- 6 - The unit may be vented vertically as a single appliance or in a common vent with other gas-fired appliances. In common venting situations, vent connectors for other appliances must maintain a 4" (102mm) vertical separation between the vent connectors. Refer to common venting tables in the current editions of ANSI Z223.1 or CSA-B149 installation compliance codes for proper vent size.
- 7 - Gas vent clearance to combustible material is 6" (152mm) for single-wall metal pipe except where a listed clearance thimble is used. Clearance to combustible material for type B-1 vent or factory-built chimney is per manufacturer's instructions.

8 - The vent connector shall be supported without any dips or sags. Vertical gas vents shall be supported in accordance with their listing and manufacturers' instructions. Any horizontal sections of vent connector runs shall have a slope up to the vertical vent of at least 1/4" (6mm) per foot (305mm).

9 - All vertical type B-1 vents, vertical single-wall metal pipe (commercial applications), or listed chimney lining systems must be terminated with a UL-listed (or other equivalent agency) vent cap or listed roof assembly.

10 - The gas vent must extend at least 2 feet (0.6m) above the highest point where it passes through a roof of a building unless otherwise specified by ANSI Z223.1 or CSA-B149 installation compliance codes. The gas vent must also extend at least 2 feet (0.6m) higher than any part of a building within a horizontal distance of 10 feet (3.0m). The gas vent must extend at least 5 feet (1.5m) above the highest connected equipment flue collar.

TABLE 3

LS25-030/400 CONNECTION PIPE SIZES

Model	Combustion Air Inlet in. (mm)	Flue Outlet in. (mm)
030, 045	3 (76)	4 (102) ¹
060, 075, 090, 105	4 (102)	4 (102)
125, 150, 175, 200, 250, 300	4 (102)	5 (127)
350, 400	5 (127)	6 (152)

¹Unit flue connection is 4 in. diameter. 30 and 45 size units are approved for use with 3 in. venting. A 4 in. X 3 in. diameter transition must be field-provided for 3 in. venting.

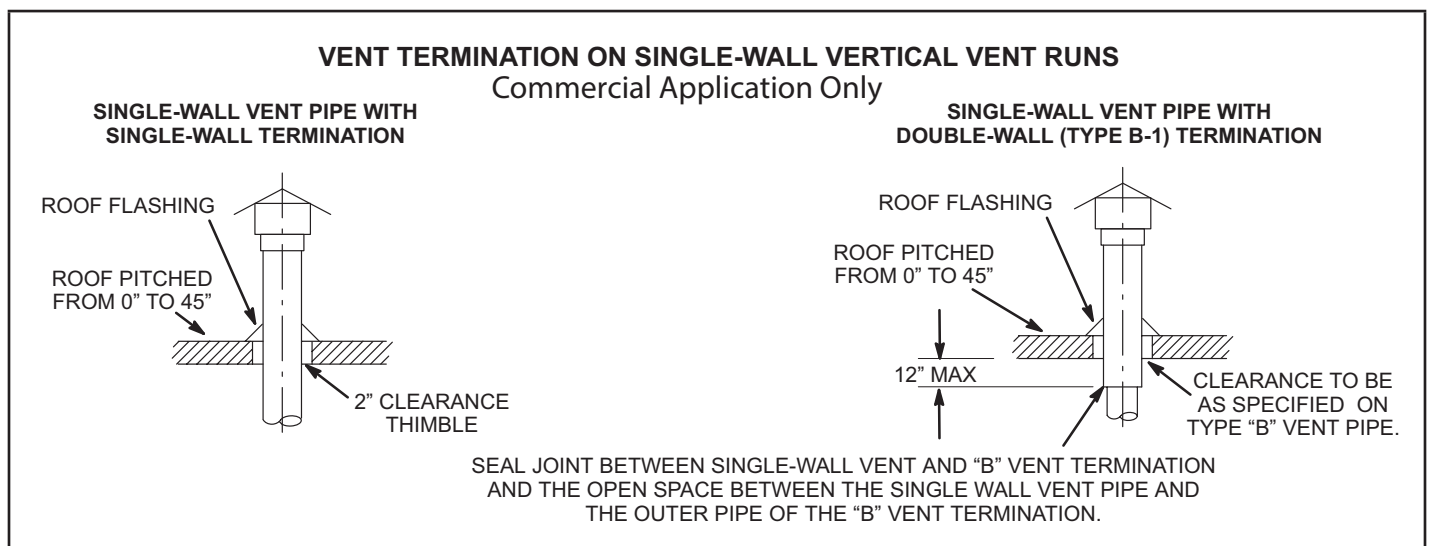
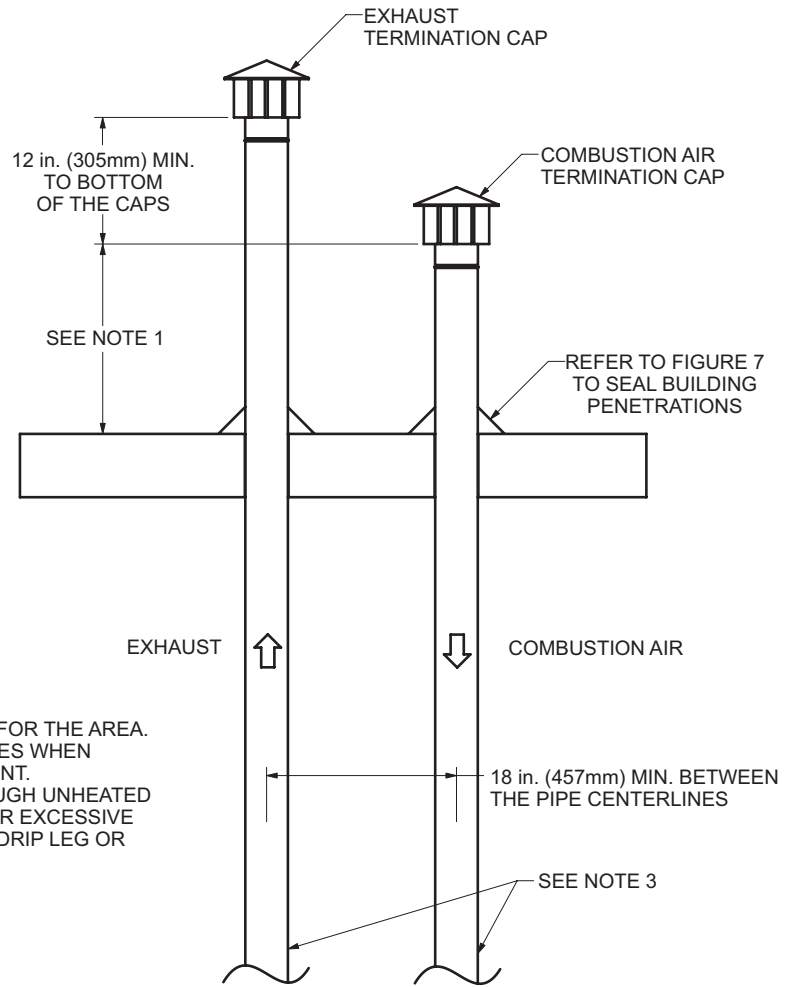

FIGURE 7

**VERTICAL VENTING - SEPARATED COMBUSTION UNIT HEATERS
030K - 400K BTUH**



NOTES:

1. 24 in. (610mm) MIN. + SNOW DEPTH (MAX) FOR THE AREA.
2. REFER TO CLEARANCES TO COMBUSTIBLES WHEN DETERMINING THE VENTING ARRANGEMENT.
3. INSULATE ANY SECTIONS PASSING THROUGH UNHEATED SPACES TO MINIMIZE CONDENSATION. FOR EXCESSIVE CONDENSATION PROBLEM, A TEE WITH A DRIP LEG OR CLEAN-OUT MAY BE REQUIRED.

FIGURE 8

HORIZONTAL VENTING

NOTE - Common venting is not allowed when horizontally venting the unit heater.

NOTE - Precautions must be taken to prevent degradation of building materials by flue products.

These unit heaters are a Category III appliance when vented horizontally.

- 1 - In residential applications, horizontal gas vent piping must be in compliance with UL 1738 for installations in the United States, and ULC S636 for installations in Canada. Refer to venting sections for vent termination clearance requirements.
- 2 - The minimum horizontal vent length is 5 feet(1.5m).
- 3 - Refer to table 4 for maximum horizontal vent lengths.
- 4 - If possible, do not terminate the horizontal vent through a wall that is exposed to prevailing wind. Exposure to excessive winds can affect unit performance. If such a termination is necessary, use a wind block to protect the vent termination from direct winds.
- 5 - Vent terminations must be free from obstructions and at least 12”(305mm) above grade level and maximum snow height.
- 6 - Do not install a horizontal vent termination directly below roof eaves or above a public walkway, or any other area where condensate dripping may be troublesome and may cause some staining. Avoid windows where steam may cause fogging or ice buildup.
- 7 - Minimum clearance for horizontal vent termination from any door, window, non-mechanical air supply inlet is 4 feet(1.2m) below or to the side of opening; 1 foot(0.3m) above opening horizontally for United States installations. In Canada, minimum clearance for horizontal vent termination from any door, window, non-mechanical air supply inlet or the combustion air inlet to any other appliance is 12 inches(305mm) for appliances >10,000 to 100,000 Btuh, and 36 inches(914mm) for appliance >100,000 Btuh.
- 8 - Vent terminal clearance to each side of a centerline extended above a meter/regulator assembly and service regulator vent outlet must be in accordance with local installation codes and the requirements of the gas supplier for installations in the United States. In Canada the clearance to each side of a centerline extended above meter/regulator assembly and service regulator vent outlet must be 3 feet(1m) within a height 15 feet(4.5m) above the meter/regulator assembly and 3 feet(1m) to a service regulator vent.
- 9 - Vent termination clearance to an unvented soffit or within 2 feet(0.6m) horizontally of a ventilated soffit must be in accordance with local installation codes and the requirements of the gas supplier.

- 10 - When a vent termination is inside a corner formed by two exterior walls the clearance must be in accordance with local installation codes and the requirements of the gas supplier.
- 11 - Vent termination must be a minimum of 3 feet (1m) above any forced air inlet (includes fresh air inlet for other appliance, such as a dryer) if within 10 feet(3m) horizontally for United States installations. In Canada, vent termination must have 6 feet(2m) minimum clearance to a mechanical air-supply inlet of any building.
- 12 - When termination is routed through combustible wall, vent termination must be supported using a firestop to maintain clearances specified on unit rating plate. Inside edge of vent termination must be at least 16” (406mm) from outside wall
- 13 - All horizontal vents which use special vent pipe for use with Category III appliances must terminate with a listed termination tee. Termination must be installed in accordance with manufacturer's instructions.
- 14 - For horizontal venting, the vent pipe shall be supported with hangers no more than 3 feet (1m) apart to prevent movement after installation.
- 15 - Select a wall termination point that will maintain either a 1/4” (6mm) per foot (305mm) rise (upward slope) or a 1/4” (6mm) per foot fall (downward slope) of horizontal run of vent pipe.
- 16 - For upward sloped vent, a condensate tee and drain must be installed within the first 5 feet(1.5m) from the unit heater to protect the appliance (see figure 9). If a flexible condensate drain line is used, the drain line must include a loop filled with water to prevent combustion products from entering the structure. If the unit is shut down for an extended period of time and will be exposed to sub-freezing temperatures, the condensate may freeze.
- 17 -For downward sloped vent, condensate drainage can be collected in a tee pipe section (figure 10) with drain loop similar to one used for upward slope vent, or allowed to drip through the vent termination, if permitted by authorities (figure 11).

TABLE 4
MAXIMUM HORIZONTAL VENT CONNECTOR AND HORIZONTAL VENT PIPE LENGTHS

No. of Elbows	30, 45, 60, 75, 90, 105, 125, 125, 150, 175, 200, 350, 400		250 & 300	
	ft	m	ft	m
1	25	7.6	35	10.7
2	20	6.1	30	9.1
3	15	4.6	25	7.6
4	10	3.0	20	6.1
5	5	1.5	15	4.6
6	-	-	10	3.0
7	-	-	5	1.5

CONDENSATE DRAIN THROUGH TEE PIPE AND DRAIN LOOP

UPWARD SLOPE ON HORIZONTAL VENT

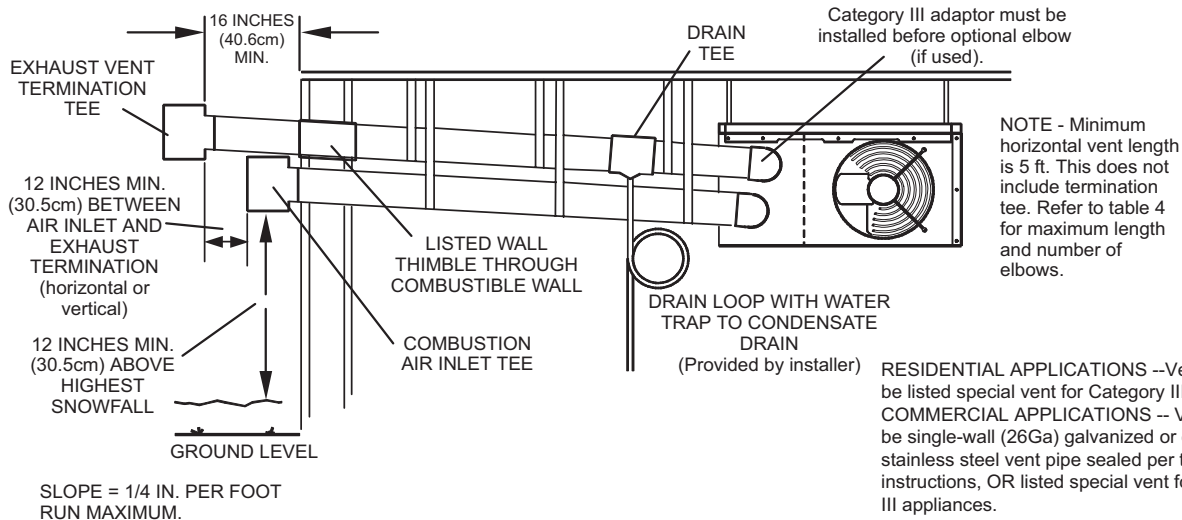

COMMON VENTING NOT ALLOWED WHEN HORIZONTALLY VENTING THE UNIT HEATER.

FIGURE 9

CONDENSATE DRAIN THROUGH TEE PIPE AND DRAIN LOOP

DOWNWARD SLOPE ON HORIZONTAL VENT

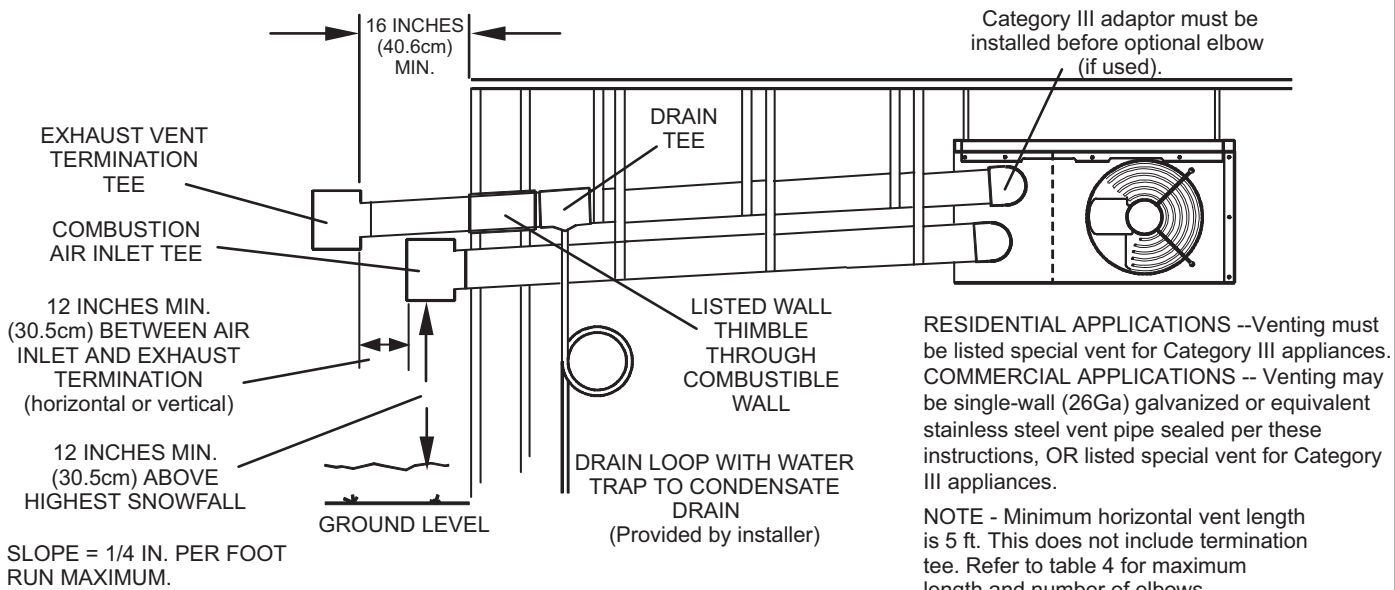

COMMON VENTING NOT ALLOWED WHEN HORIZONTALLY VENTING THE UNIT HEATER.

FIGURE 10

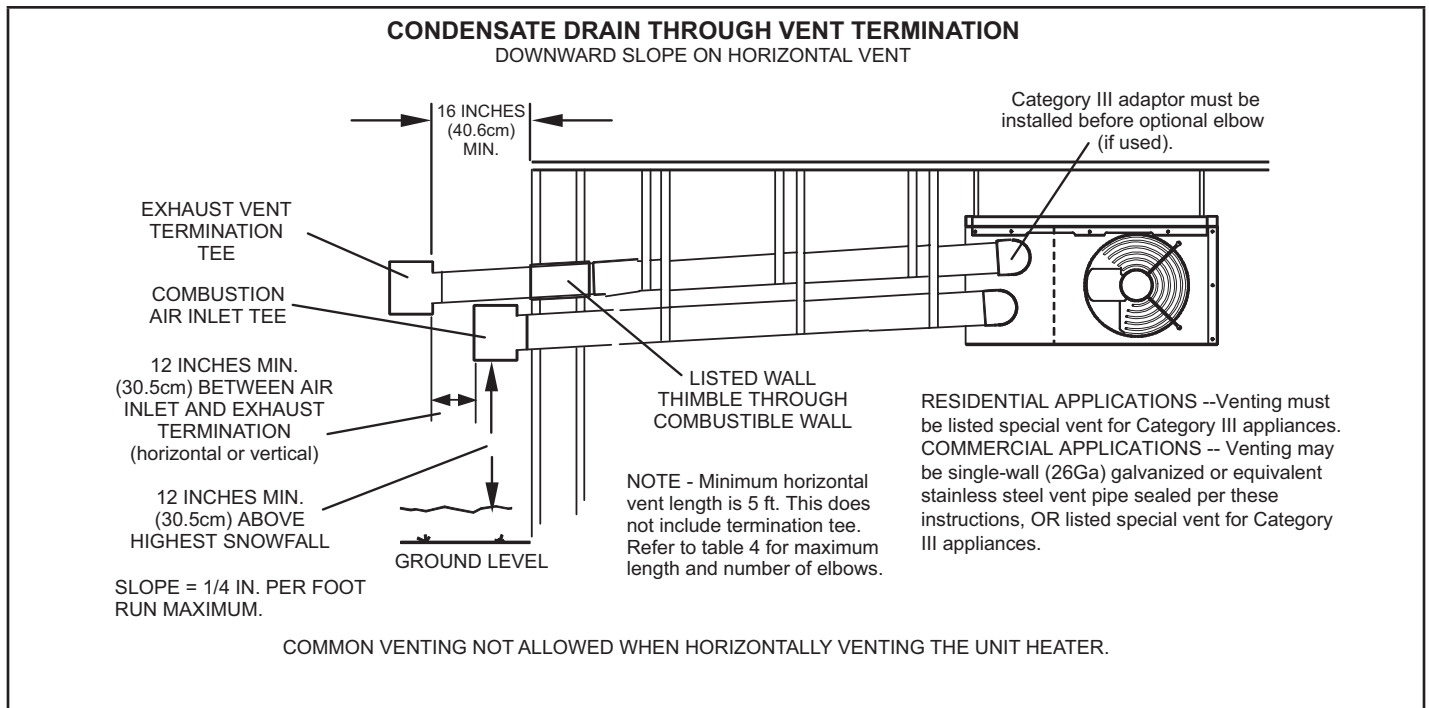

FIGURE 11

VENTING USING A MASONRY CHIMNEY

The following additional requirements apply when a lined masonry chimney is being used to vent the compact unit heater.

⚠ IMPORTANT

Single appliance venting of a fan-assisted unit heater into a tile lined masonry chimney (interior or outside wall) is prohibited. The chimney must first be lined with either type "B-1" vent or an insulated single-wall flexible vent lining system, sized in accordance with venting tables in the ANSI Z223.1, or CSA-B149 installation compliance codes.

1 - Masonry chimneys used to vent Category I units heaters must be either tile-lined or lined with a listed metal lining system or dedicated gas vent. Unlined masonry chimneys are prohibited. A category I appliance must never be connected to a chimney that is servicing a solid fuel appliance. If a fireplace chimney flue is used to vent this appliance, the fireplace opening must be permanently sealed.

2 - A fan-assisted unit heater may be commonly vented into an existing lined masonry chimney provided:

- a. The chimney is currently serving at least one draft-hood equipped appliance.
- b. The vent connector and chimney are sized in accordance with venting tables.

3 - A "B1" double-wall vent or masonry chimney liner shall terminate above the roof surface with a listed cap or a listed roof assembly in accordance with the terms of their respective listings and the vent manufacturer's instructions.

4 - Do not install a manual damper, barometric draft regulator, or flue restrictor between the unit heater and the chimney.

5 - If type "B1" double-wall vent is used inside a chimney, no other appliance can be vented into the chimney. Outer wall of type "B" vent pipe must not be exposed to flue products.

6 - Insulation for the flexible vent pipe must be an encapsulated fiberglass sleeve recommended by the flexible vent pipe manufacturer.

7 - The space between liner and chimney wall should NOT be insulated with puffed mica or any other loose granular insulating material.

- 8 - If B-1 vent or an insulated flexible vent pipe cannot be used as liners, the chimney must be rebuilt to accommodate one of these methods or some alternate approved method must be found to vent the appliance. When inspection reveals that an existing chimney is not safe for the intended purpose, it shall be rebuilt to conform to nationally recognized standards, lined or relined with suitable materials or replaced with a gas vent or chimney suitable for venting unit heaters. The chimney passageway must be checked periodically to ensure that it is clear and free of obstructions.

REMOVAL OF UNIT FROM COMMON VENT

In the event that an existing unit heater is removed from a venting system commonly run with separate gas appliances, the venting system is likely to be too large to properly vent the remaining attached appliances. The following test should be conducted while each appliance is in operation and the other appliances are not in operation, yet remain connected to the common venting system. If the venting system has been installed improperly, the system must be corrected.

- 1 - Seal any unused openings in the common venting system.
- 2 - Visually inspect the venting system for proper size and horizontal pitch. Determine there is no blockage or restriction, leakage, corrosion, or other deficiencies which could cause an unsafe condition.
- 3 - In so far as is practical, close all building doors and windows and all doors between the space in which the appliances remaining connected to the common venting system are located and other spaces of the building. Turn on clothes dryers and any appliances not connected to the common venting system. Turn on any exhaust fans, such as range hoods and bathroom exhausts, so they will operate at maximum speed. Do not operate a summer exhaust fan. Close fireplace dampers.
- 4 - Follow the lighting instructions. Place the appliance being inspected in operation. Adjust thermostat so appliance will operate continuously.
- 5 - Test for spillage at the draft hood relief opening after five minutes of main burner operation. Use the flame of a match or candle, or smoke from a cigarette, cigar, or pipe.
- 6 - After it has been determined that each appliance remaining connected to the common venting system properly vents when tested as outlined above, return doors, windows, exhaust fans, fireplace dampers and any other gas-burning appliance to their previous condition of use.
- 7 - If improper venting is observed during any of the above tests, the common venting system must be corrected. The common venting system should be resized to approach the minimum size as determined by using the appropriate tables in Appendix G in the current editions of the ANSI Z223-1, or the appropriate Category I Natural Gas and Propane appliances venting sizing tables in the current standards of the CSA-B149 for installation compliance codes.

Electrical Connections

NOTE - Local codes may supersede any of the provisions outlined in this instruction.

THERMOSTAT WIRING

Unit heaters use a direct spark ignition system. There is no pilot necessary as the spark lights the main burner when the gas valve is turned on. The direct spark ignition control board (A3) emits radio noise as the sparking process is under way. The level of energy may be sufficient to disturb a logic circuit in a microprocessor controlled thermostat. It is recommended that an isolation relay be used when connecting the unit heaters to a microprocessor controlled thermostat.

250-400 Units Only: Units are shipped from the factory in two-stage heating mode. When using a single-stage thermostat or control, jumper W1 & W2 terminals on P367 5-pin thermostat plug.

Install the thermostat according to instructions provided. Route thermostat wiring into the unit heater using the thermostat inlet(s) shown in the Unit Heater dimensions in the front of this instruction. Use 18 gauge wire or larger for thermostat connections.

Connect thermostat wires to 5-pin P367 thermostat plug located on the A3 ignition control board. See figure 12. For ease of installation, disconnect P367 plug from J367, make wire connections, and replace P367. Refer to diagram on unit and appropriate diagram in this instruction.

An additional thermostat wire must be run to terminal "G" on heater when continuous blower is desired.

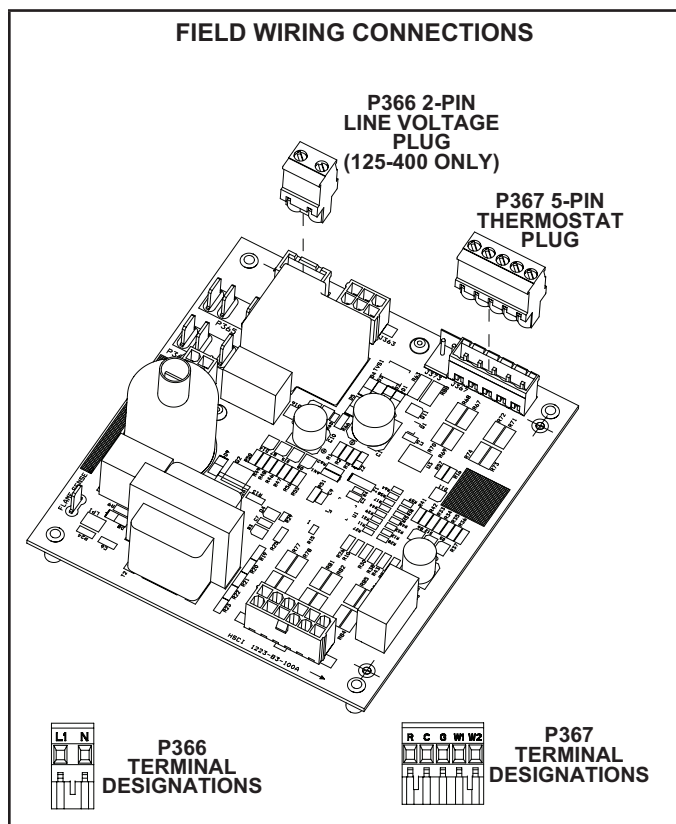

FIGURE 12

LINE VOLTAGE WIRING

- 1 - Install a separate fused disconnect switch with the fuse sized according to the blower motor size.

NOTE - Electrically ground unit in accordance with local codes or, in the absence of local codes, in accordance with the current editions of the ANSI/NFPA No. 70, National Electrical Code or CSA C22.1, Canadian Electrical Code, Part 1.

NOTE - Uninsulated ground wires must be wrapped in electrical tape to avoid damage to the electrical system.

- 2 - Make line voltage connections as shown in figure 13. Connect wires to 2-pin P366 plug located on the A3 ignition control board. For ease of installation, disconnect P366 plug from J366, make wire connections, and replace P366. Refer to wiring diagram on unit and the appropriate typical diagram in this manual.

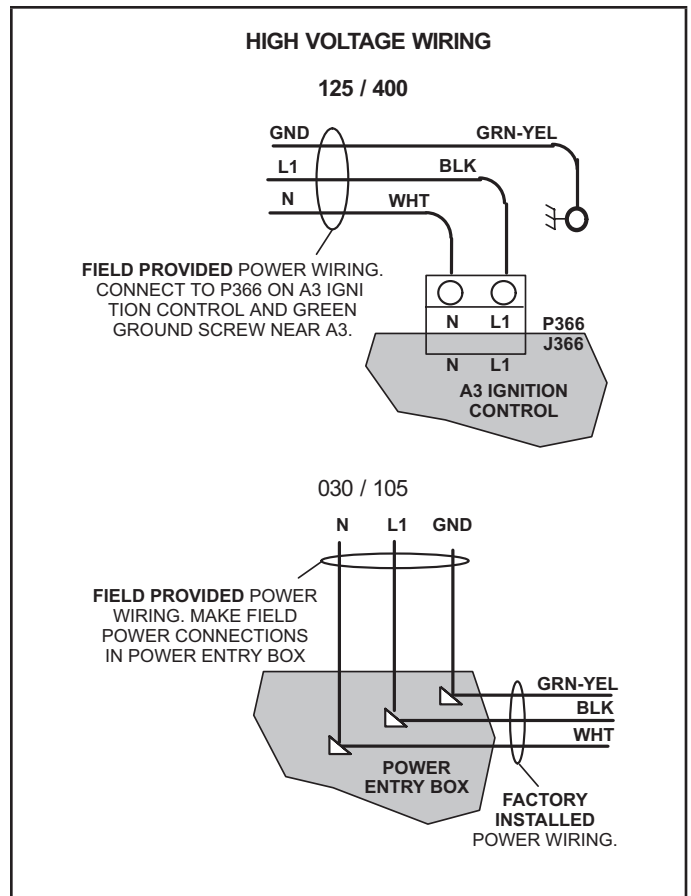

FIGURE 13



1.0

537992-02

01

HIGH VOLTAGE POWER CONNECTIONS



02

FIELD PROVIDED POWER WIRING. MAKE FIELD POWER CONNECTIONS IN POWER ENTRY BOX.
FACTORY INSTALLED POWER WIRING.

03



EQUIPMENT GROUND

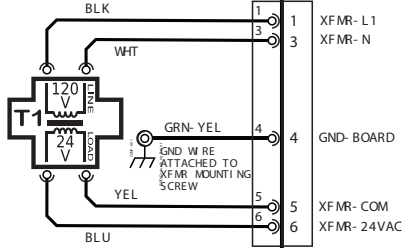

04

LOW VOLTAGE THERMOSTAT CONNECTIONS

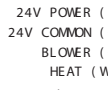

FIELD PROVIDED CLASS II 24VAC THERMOSTAT WIRING

05

SET THERMOSTAT HEAT ANTICIPATION AS FOLLOWS
HONEYWELL VALVE: .7
WHITE ROGERS VALVE: .5

WARNING

DISCONNECT ALL POWER BEFORE SERVICING. ELECTRIC SHOCK HAZARD. CAN CAUSE INJURY OR DEATH. UNIT MUST BE GROUNDED IN ACCORDANCE WITH NATIONAL AND LOCAL CODES.

06

FOR USE WITH COPPER CONDUCTORS ONLY. REFER TO UNIT RATING PLATE FOR MINIMUM CIRCUIT AMPACITY AND MAXIMUM OVERCURRENT PROTECTION SIZE.

IF ANY WIRE IN THIS APPLIANCE IS REPLACED, IT MUST BE REPLACED WITH WIRE OF LIKE SIZE, RATING AND INSULATION THICKNESS.

07

NOTES		⚠
MAXIMUM LOAD NOT TO EXCEED 20VA AT 24VAC, CLASS 2.		1
S43 MAY BE FIELD OR FACTORY INSTALLED ON LP GAS UNITS ONLY.		2

08

Model:	LF25 Unit Heater; LS25 Separated Combustion Unit Heater				
	Heat Input - 030k-105k BTUH				
Voltage:	120/60/1				
Supersedes:	537992-01	Form No:	537992-02	Rev:	1.0

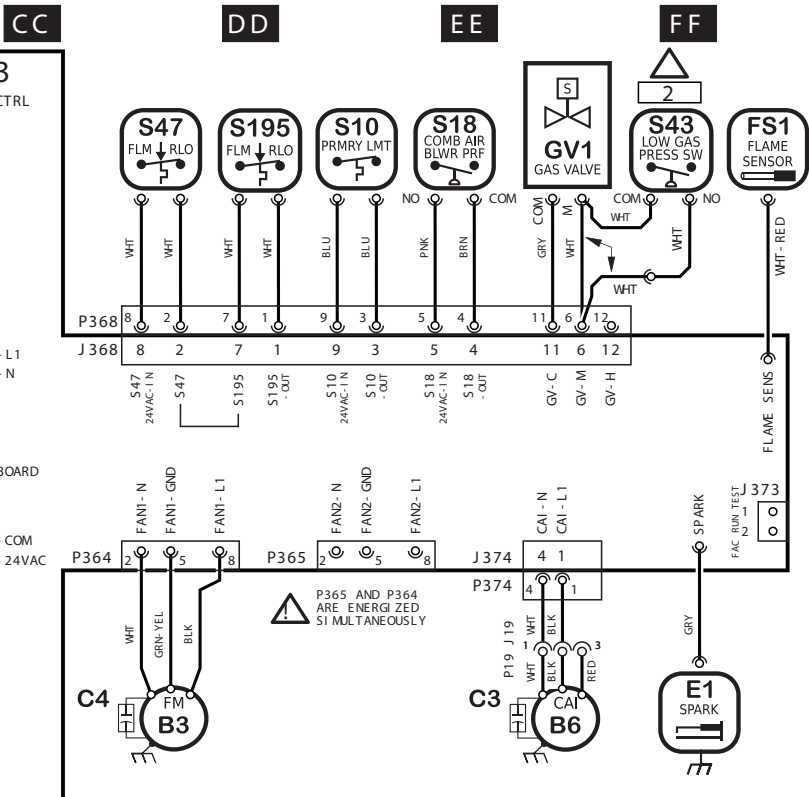

KEY LIST		
LOCATION	COMPONENT TAG	COMPONENT DESCRIPTION
CONTROL		
CC01	A3	IGN CTRL CONTROL, BURNER
POWER		
BB03	T1	TRANSFORMER, CONTROL
INPUT		
FF01	FS1	FLAME SENSOR SENSOR, FLAME
DD01	S10	PRMRY LMT LIMIT, PRIMARY, GAS
EE01	S18	COMB AIR BLWR PRF SWITCH, COMBUSTION AIR BLOWER PROOFING
DD01	S47	FLM RLO SWITCH, FLAME ROLLOUT 1, BURNER 1
DD01	S195	FLM RLO SWITCH, FLAME ROLLOUT 2, BURNER 1
OUTPUT		
DD04	B3	FM MOTOR, FAN
EE04	B6	CAI MOTOR, COMBUSTION AIR, INDUCER
EE04	C3	-- CAPACITOR, MOTOR, CAI
DD04	C4	-- CAPACITOR, MOTOR, FAN
FF04	E1	SPARK IGNITER, SPARK
FF01	GV1	GAS VALVE VALVE, GAS
FF01	S43	LOW GAS PRESS SW LOW GAS PRESSURE SWITCH, GV1



2.0

538025-02

01

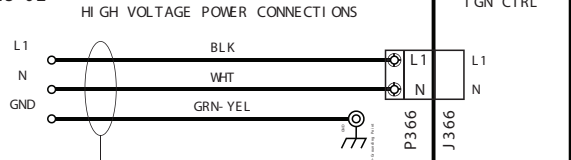

02

FIELD PROVIDED POWER WIRING. CONNECT TO P366 AND GREEN GROUND SCREW LOCATED INSIDE UNIT.

03

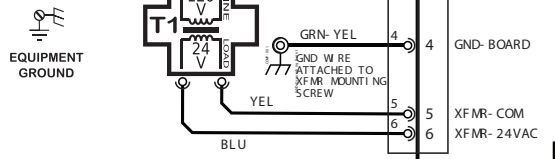

04

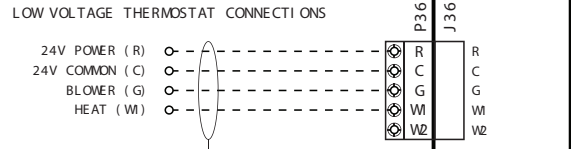

05

FIELD PROVIDED CLASS II 24VAC THERMOSTAT WIRING

SET THERMOSTAT HEAT ANTICIPATION AS FOLLOWS
HONEYWELL VALVE: .7
WHITE ROGERS VALVE: .5

WARNING

06

DISCONNECT ALL POWER BEFORE SERVICING. ELECTRIC SHOCK HAZARD, CAN CAUSE INJURY OR DEATH. UNIT MUST BE GROUNDED IN ACCORDANCE WITH NATIONAL AND LOCAL CODES.

FOR USE WITH COPPER CONDUCTORS ONLY. REFER TO UNIT RATING PLATE FOR MINIMUM CIRCUIT AMPACITY AND MAXIMUM OVERCURRENT PROTECTION SIZE.

IF ANY WIRE IN THIS APPLIANCE IS REPLACED, IT MUST BE REPLACED WITH WIRE OF LIKE SIZE, RATING AND INSULATION THICKNESS.

07

NOTES	
MAXIMUM LOAD NOT TO EXCEED 20VA AT 24VAC, CLASS 2.	1

08

Model:	LF25 Unit Heater; LS25 Separated Combustion Unit Heater
	Heat Input - 125k-200k BTUH
Voltage:	120/60/1
Supersedes:	538025-01 Form No: 538025-02 Rev: 2.0

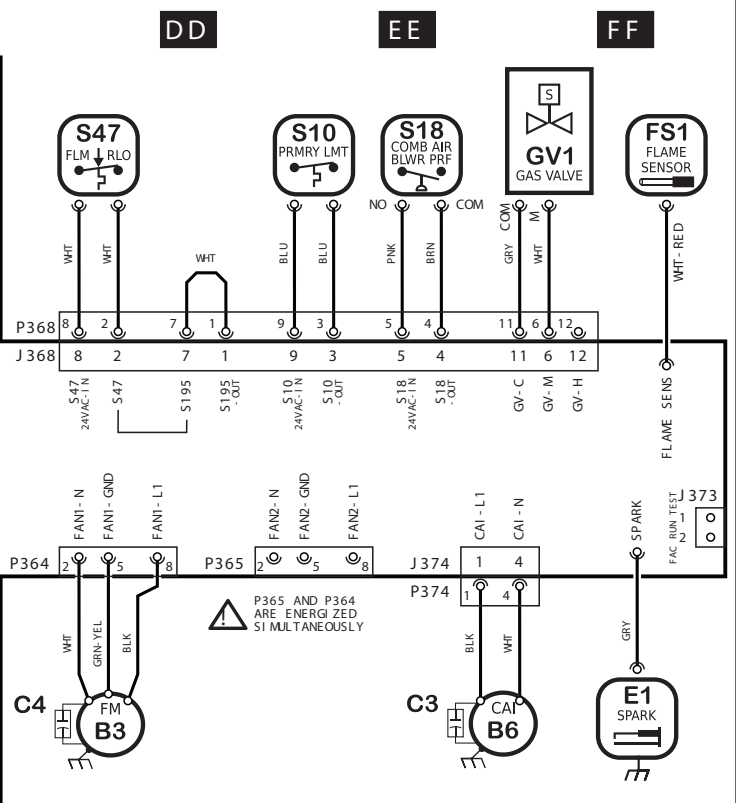

KEY LIST		
LOCATION	COMPONENT TAG	COMPONENT DESCRIPTION
CONTROL		
CC01	A3	IGN CTRL CONTROL, BURNER
POWER		
BB03	T1	TRANSFORMER, CONTROL
INPUT		
FF01	FS1	FLAME SENSOR SENSOR, FLAME
DD01	S10	PRMRY LMT LIMIT, PRIMARY, GAS
EE01	S18	COMB AIR BLWR PRF SWITCH, COMBUSTION AIR BLOWER PROOFING
DD01	S47	FLM RLO SWITCH, FLAME ROLLOUT
OUTPUT		
DD04	B3	FM MOTOR, FAN
EE04	B6	CAI MOTOR, COMBUSTION AIR, INDUCER
EE04	C3	CAPACITOR, MOTOR, CAI
DD04	C4	CAPACITOR, MOTOR, FAN
FF04	E1	SPARK IGNITER, SPARK
FF01	GV1	GAS VALVE VALVE, GAS



538024-02

01

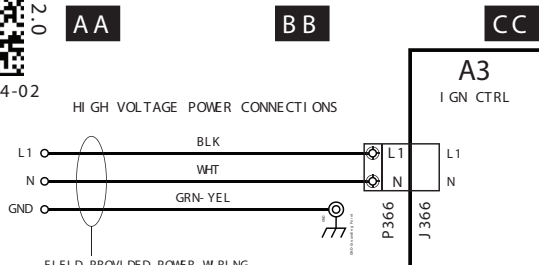

02

FIELD PROVIDED POWER WIRING. CONNECT TO P366 AND GREEN GROUND SCREW LOCATED INSIDE UNIT.

03

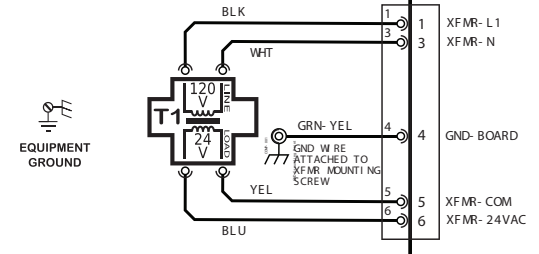

04

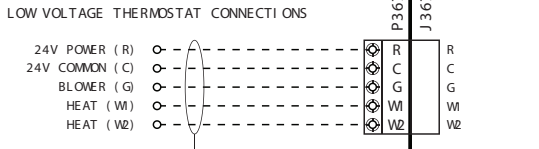

05



SET THERMOSTAT HEAT ANTICIPATION AS FOLLOWS
 HONEYWELL VALVE: .7
 WHITE ROGERS VALVE: .5

WARNING

06

DISCONNECT ALL POWER BEFORE SERVICING. ELECTRIC SHOCK HAZARD, CAN CAUSE INJURY OR DEATH. UNIT MUST BE GROUNDED IN ACCORDANCE WITH NATIONAL AND LOCAL CODES.

FOR USE WITH COPPER CONDUCTORS ONLY. REFER TO UNIT RATING PLATE FOR MINIMUM CIRCUIT AMPACITY AND MAXIMUM OVERCURRENT PROTECTION SIZE.

07

IF ANY WIRE IN THIS APPLIANCE IS REPLACED, IT MUST BE REPLACED WITH WIRE OF LIKE SIZE, RATING AND INSULATION THICKNESS.

NOTES	
MAXIMUM LOAD NOT TO EXCEED 20VA AT 24VAC, CLASS 2.	1

08

Model:	LF25 Unit Heater; LS25 Separated Combustion Unit Heater		
	Heat Input - 250k-400k BTUH		
Voltage:	120/60/1		
Supersedes:	538024-01	Form No:	538024-02
		Rev:	2.0

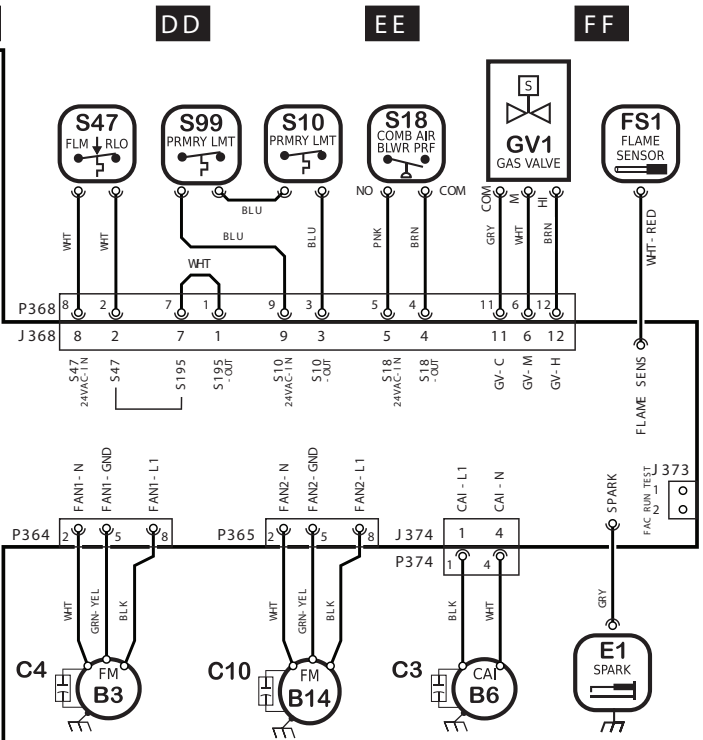

KEY LIST

LOCATION	COMPONENT TAG	COMPONENT DESCRIPTION
CONTROL		
CC01	A3	IGN CTRL CONTROL, BURNER
POWER		
BB03	T1	TRANSFORMER, CONTROL
INPUT		
FF01	FS1	FLAME SENSOR SENSOR, FLAME
DD01	S10	PRMRY LMT LIMIT, PRIMARY 1, GAS
EE01	S18	COMB AIR BLWR PRF SWITCH, COMBUSTION AIR BLOWER PROOFING
DD01	S47	FLM RLO SWITCH, FLAME ROLLOUT
DD01	S99	PRMRY LMT LIMIT, PRIMARY 2, GAS
OUTPUT		
DD04	B3	FM MOTOR, FAN 1
EE04	B6	CAI MOTOR, COMBUSTION AIR, INDUCER
DD04	B14	FM MOTOR, FAN 2
EE04	C3	CAPACITOR, MOTOR, CAI
DD04	C4	CAPACITOR, MOTOR, FAN 1
DD04	C10	CAPACITOR, MOTOR, FAN 2
FF04	E1	SPARK IGNITER, SPARK
FF01	GV1	GAS VALVE VALVE, GAS

Gas Connection

When connecting gas supply, the length of the run from the meter must be considered in determining the pipe size to avoid excessive pressure drop. A line pressure of 7" w.g. (178mm w.g.) for natural gas should be maintained when sizing piping. For correct sizing of piping, consult the utility having jurisdiction.

A drip leg should be installed in the vertical pipe run to the unit. In some localities, codes may require that a manual main shutoff valve and union (furnished by installer) be installed external to the unit. Union must be of the ground joint type. A drip leg should be readily accessible to permit cleaning and emptying. See figure 14.

NOTE - If a switch box is mounted over electrical knock-outs on back of unit, leave a minimum of 4" (102mm) clearance between switch box and drip leg.

A 1/8" NPT plugged tap shall be installed immediately upstream of the gas supply connection to the heater.

NOTE - Compounds used on threaded joints of gas piping must be resistant to the actions of liquefied petroleum gases.

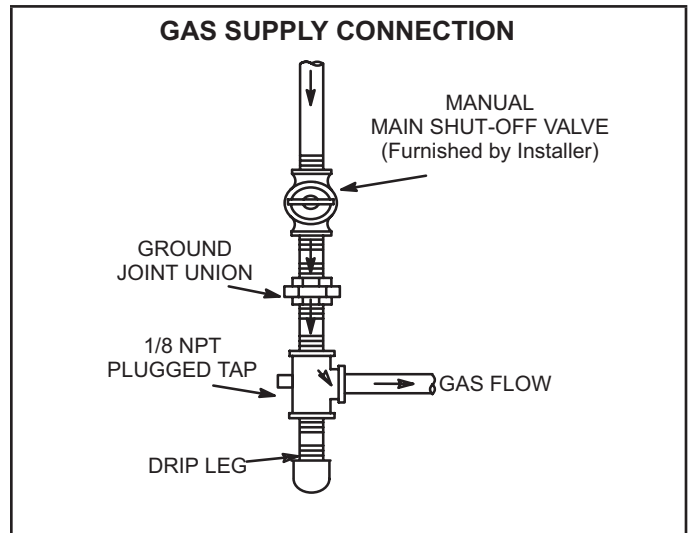

FIGURE 14

Leak Check

After gas piping is completed, carefully check all piping connections, (field and factory), for gas leaks. Use a soap solution or other preferred means.

CAUTION

DO NOT use matches, candles, flame or other sources of ignition to check for gas leaks.

The appliance must be isolated from the gas supply piping system by closing its individual manual gas shutoff valve during any pressure testing of the gas supply system at test pressures equal to or greater than 1/2 psig (3.45kPa).

IMPORTANT

The heater and its individual shut off valve must be disconnected from the gas supply piping system during any pressure testing of that system at test pressures in excess of 1/2 psig (3.45kPa). See figure 14.

NOTE - In case emergency shutdown is required, shut down main gas valve and disconnect main power to unit. These devices should be properly labeled by the installer.

Unit Start-Up

FOR YOUR SAFETY READ BEFORE LIGHTING

WARNING



Electric shock hazard. Can cause injury or death. Do not use this unit if any part has been under water. Immediately call a qualified service technician to inspect the unit and to replace any part of the control system and any gas control which has been under water.

WARNING

Install, operate and maintain unit in accordance with manufacturer's instructions to avoid exposure to fuel substances or substances from incomplete combustion which can cause death or serious illness.

WARNING



Danger of explosion. Can cause injury or product or property damage. If overheating occurs or if gas supply fails to shut off, shut off the manual gas valve to the appliance before shutting off electrical supply.

Oil residues, from manufacturing of the heat exchanger, may cause the unit to produce smoke when first started; there is no health hazard associated with this. As a precaution, open doors and windows and alert people in the building there may be smoke on start-up.

Return Air Temperature Requirements:

The following return air temperatures must be maintained for optimum unit operation and extended life of the heat exchanger. Failure to comply with the conditions will void the warranty.

Minimum return air temperature for units built with aluminized steel heat exchanger: 55°F

Minimum return air temperature for units built with stainless steel heat exchanger: 45°F

Maximum return air temperature: 85°F

WARNING



Electric shock hazard. Can cause injury or death. Before attempting to perform any service or maintenance, turn the electrical power to unit OFF at disconnect switch(es). Unit may have multiple power supplies.

WARNING



Danger of explosion. Can cause injury or product or property damage. You must follow these instructions exactly.

BEFORE LIGHTING smell all around the appliance area for gas. Be sure to smell next to the floor because some gas is heavier than air and will settle on the floor.

Use only your hand to move the switch. Never use tools. If the switch will not move by hand, do not try to repair it, call a qualified service technician. Force or attempted repair may result in a fire or explosion.

OPERATION OF WHITE RODGERS 36H SERIES VALVE (FIGURE 15) AND WHITE RODGERS 36G SERIES GAS VALVE (FIGURE 16)

NOTE - STOP! Read the safety information at the beginning of this section.

- 1 - Set thermostat to lowest setting.
- 2 - Turn off all electrical power to appliance.
- 3 - This appliance is equipped with an ignition device which automatically lights burners. **DO NOT attempt to light the burners manually.**
- 4 - Move switch to OFF.
- 5 - Wait five minutes to clear out any gas. If you then smell gas, **STOP!** Immediately call your gas supplier from a neighbor's phone. Follow the gas supplier's instructions. If you do not smell gas, go to next step.
- 6 - Move switch to **ON**.
- 7 - Turn on all electric power to unit.
- 8 - Set thermostat to desired setting.
- 9 - If appliance still will not operate, follow the instructions **"To Turn Off Gas to Unit"** and call your service technician or gas supplier.

To Turn Off Gas to Unit

- 1 - Set thermostat to lowest level.
- 2 - Turn off all electrical power to unit if service is to be performed.
- 3 - Move switch to OFF

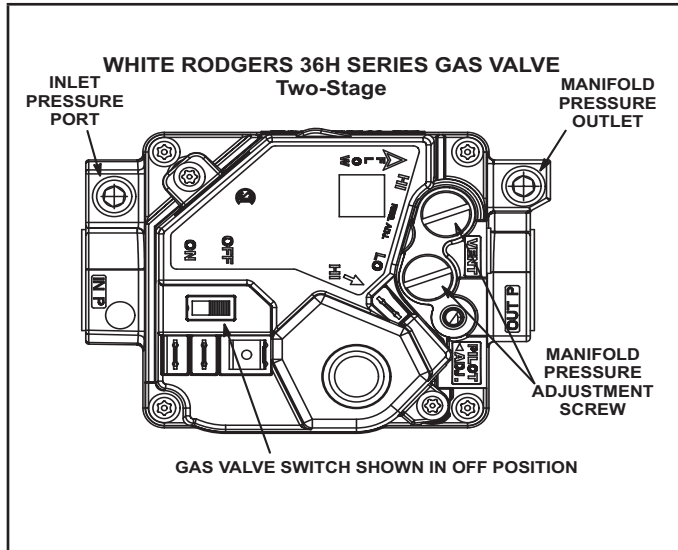

FIGURE 15

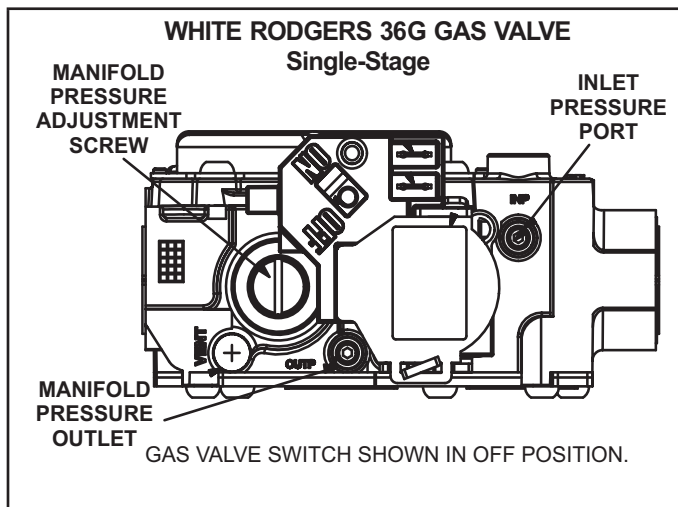

FIGURE 16

Heating Sequence of Operation

- 1 - When the thermostat calls for heat, the combustion air inducer starts immediately.
- 2 - Combustion air pressure switch proves inducer operation before allowing ignition sequence to start. This switch is factory set and no adjustment is necessary.
- 3 - After pre-purge of approximately 30 seconds, the spark ignition is energized and the solenoid valves open in the gas valve.
- 4 - The spark then ignites the gas, the ignition sensor proves the flame and the combustion process continues.
- 5 - In the event that the flame is not detected after the first 10-second trial for ignition, the controller will repeat steps 3 and 4 an additional two times before locking out the gas valve. Ignition control will then automatically repeat steps 3, 4, and 5 after 60 minutes.

NOTE - To interrupt the 60-minute lockout period, move thermostat from "Heat" to "OFF" then back to "Heat." Heating sequence then restarts at step 1.

- 6 - The burners must light without noticeable crossover delay. There must be no flame lifting from the burner heads, flashback or burning within the burner. The flames should be predominantly blue in color and should be approximately centered in the tubes with no apparent impingement taking place.
- 7 - The ignition control will energize the fan approximately 30 seconds after ignition is established.
- 8 - After the thermostat demand is satisfied the gas valve is closed. Thirty seconds after the demand is satisfied, the combustion air inducer is shut off.
- 9 - The ignition control will shut off the system fan approximately 150 seconds after the gas valve is de-energize.

Ignition Control LED

The ignition control contains a red LED which indicates the following:

**TABLE 5
IGNITION CONTROL LED**

LED	UNIT OPERATION
Slow Flash*	Normal Operation - No call for heat
Fast Flash	Normal Operation - Call for heat
2 Flashes	System lockout - failed to detect or sustain flame
3 Flashes	Pressure switch failed closed before CAI is energized or failed open after CAI is energized
4 Flashes	High limit (S10) switch open
5 Flashes	Flame sensed and gas valve (GV1) not energized
6 Flashes	On-board microprocessor fault.
7 Flashes	Pressure switch (S18) closed with inducer off.
8 Flashes	Rollout switch (S47/S195) open. Cycle-power to reset.
Steady On	Control board (A3) failure
Steady Off	Internal control board (A3) failure or not power.

High Altitude Adjustments

In Canada, certification for installation at altitudes over 4500 feet (1372m) above sea level is the jurisdiction of local authorities. Lennox recommends derating 4%/1000 feet above 4,500 feet. Refer to table 6 for natural gas manifold pressures and the Engineering Handbook for high altitude kit part numbers.

Units may be fired at full input up to 2000 feet. (610m) above sea level. Above 2000 feet (610m), manifold pressure must be adjusted. Adjust pressure regulator to pressure shown in table 6.

**TABLE 5
CANADA - NATURAL GAS MANIFOLD PRESSURES
[inch w.g. (kPa)]**

Unit	Altitude in Feet (Meters)					
	0-2000 (0-610)	2001-4500 (610-1372)	4501-5500 (1372-1676)	5501-6500 (1677-2012)	6501-7500 (2012-2286)	7501-9500 (2286-2896)
125, 150, 175, 200	3.5 (0.87)	3.1 (0.77)	2.8 (0.70)	2.6 (0.65)	See Kit Instruction	
250, 300, 350, 400	3.7 (0.92)	3.2 (0.80)	2.9 (0.72)	2.8 (0.70)	2.6 (0.65)	See Kit Instruction
250, 300, 350	3.7* (0.92)	3.3* (0.82)	2.9* (0.72)	2.8* (0.70)	2.6* (0.65)	See Kit Instruction
	1.6** (0.40)					
400	1.7** (0.42)					

* High Fire **Low Fire

NOTE - A natural to LP/propane gas changeover kit is required to convert the unit in the field. Refer to the installation instructions supplied with the changeover kit for conversion procedure.

In the US, units may be fired at full input up to 2000 feet (610m) above sea level. Above 2000 feet (610m), unit must be de-rated by four percent per 1000 feet for installation above 2000 feet. The de-rate may be accomplished by adjusting the manifold pressure. Refer to table 7 for natural gas manifold pressures and the Engineering Handbook for high altitude kit part numbers.

**TABLE 6
US - NATURAL GAS MANIFOLD PRESSURES
[inch w.g. (kPa)]**

Unit	Altitude in Feet (Meters)				
	0-2000 (0-610)	2001-3000 (610-914)	3001-4000 (915-1219)	4001-5000 (1220-1524)	5001-10000 (1524-3048)
125, 150, 175, 200	3.5 (0.87)	2.9 (0.72)	2.7 (0.67)	See Kit Instruction	
250, 300, 350, 400	3.7 (0.92)	3.1 (0.77)	2.8 (0.70)	2.6 (0.65)	See Kit Instruction
250, 300, 350	3.7* (0.92)	3.1* (0.77)	2.8* (0.70)	2.6* (0.65)	See Kit Instruction
	1.6** (0.40)				
400	1.7** (0.42)				

* High Fire **Low Fire

In some cases, it is necessary to change the pressure switch to ensure proper operation at higher altitudes. See EHB for high altitude pressure switch kits.

The combustion air inducer proving switch is factory set. No adjustment is necessary.

Gas Flow

To check for proper gas flow to the combustion chamber, determine the Btu input from the appliance rating plate. Divide this input rating by the Btu per cubic feet of available gas. Result is the required number of cubic feet per hour. Determine the flow of gas through the gas meter for two minutes and multiply by 30 to get the hourly flow of gas.

Supply Gas Pressure Adjustment

Supply pressure should be checked with unit firing at maximum rate. For Natural Gas, supply pressure should be maintained in accordance with the specified minimum and maximum supply pressures on the unit rating plate.

A natural gas to LP/propane gas changeover kit is required to convert the unit in the field. Refer to installation instructions provided with changeover kit for conversion procedure along with propane minimum and maximum supply pressures.

Supply Pressure Measurement

- 1 - Shut off the manual main supply valve (field furnished) when installing or removing the measuring device (Steps 2 and 6).
- 2 - Connect the measuring device based upon type of gas valve.

For White Rodgers 36G valve (Figure 16), an inlet post located on the gas valve provides access to the supply pressure. Open the inlet port by backing out the 3/32" hex screw one turn. Connect a piece of tubing over the inlet post and route to a measuring device to measure supply pressure.

For White Rodgers 36H valve (Figure 15), supply pressure is accessed by removing 1/8" hex screw. Remove the 1/8" hex screw and install a 1/8" fitting with hose barb. Connect tubing from the barbed fitting and route to measuring device to measure supply pressure.

- 3 – Open manual main supply valve.
- 4 - Ignite unit and let run for 5 minutes to allow for steady state conditions.
- 5 - After allowing unit to stabilize for 5 minutes, record supply pressure.

NOTE - On multiple unit installations, each unit should be checked separately, with and without other units operating. Supply pressures on both single and multiple unit installations must fall within range listed on the rating plate.

- 6 – Shut unit off and remove measuring device, tubing, or fittings, as soon as, an accurate reading has been obtained.

For White Rodgers 36G valves (Figure 16), turn the manifold 3/32" hex screw one revolution back into the gas valve.

For White Rodgers 36H valves (Figure 15), remove manifold barbed fitting and reinstall the 1/8" hex screw.

Manifold Pressure Measurement

NOTE - Pressure test adapter kit (21U27) is available from Lennox to facilitate manifold pressure measurement.

To correctly measure total manifold pressure, the pressure between the positive gas manifold and the negative burner box must be considered.

NOTE- Total manifold pressure is the sum of the positive "+" and negative "-" sides of the manifold pressure.

- 1 - Connect the test gauge positive side "+" to manifold pressure tap on gas valve as noted below for the specific gas valve.

For White Rodgers 36G valves (Figure 16) manifold pressure, back out the 3/32" hex screw one turn, connect a piece of 5/16" tubing and connect to the "+" side of the measuring device.

For White Rodgers 36H valves (Figure 15) manifold pressure, remove the 1/8" hex screw, install 1/8" fitting with hose barb, connect hose from barb to "+" side of measuring device.

- 2 - Tee into the gas valve regulator vent hose and connect to test gauge negative "-".
- 3 - Ignite unit and let run for 5 minutes to allow for steady state conditions. If unit has 2 heating inputs, start on higher input.
- 4 - After allowing unit to stabilize for 5 minutes, record manifold pressure. For natural gas, compare to value given in tables 7 or 8.
- 5 - If necessary, make adjustments. Figure 15 and 16 show adjustment screw(s) locations.
- 6 - Repeat steps 3, 4 and 5 on lower input.
- 7 - Shut unit off and remove measuring device as soon as an accurate reading has been obtained.

For White Rodgers 36G valves (Figure 16), turn the manifold 3/32" hex screw one revolution back into the gas valve.

For White Rodgers 36H valves (Figure 15), remove 1/8" fitting with hose barb and reinstall 1/8" hex screw.

- 8 - Start unit and perform leak check. Seal leaks if found.

Limit Control Switch

The limit control switch(es) is factory-set and is not field-adjustable.

Louver Vane Adjustment

Rotate louver vanes to direct airflow upward, downward, straight, or any combination of these directions.

Combustion Air Pressure Switch

This pressure switch checks for proper combustion air inducer operation before allowing an ignition trial. The switch is factory-set. No field adjustment is necessary. For high altitude applications, see the Engineering Handbook.

Flame Rollout Switch

This normally closed switch opens on a temperature rise. See the parts arrangement for location. These switches are not adjustable.

Service

CAUTION

Turn off gas and electrical power to unit before performing any maintenance or service operations on this unit. Remember to follow lighting instructions when putting unit back into operation after service or maintenance.

The unit heater and vent system shall be inspected once a year by a licensed professional service technician, or equivalent.

BURNERS

- 1 - Periodically examine burner flames for proper appearance during the heating season.
- 2 - Before each heating season examine the burners for any deposits or blockage that may have occurred.
- 3 - Clean burners as follows:
 - a. Turn off both electrical and gas supplies to unit.
 - b. Disconnect gas supply piping, high tension and sensor leads. Remove gas manifold. Remove burner box top. Remove burner cluster assembly.
 - c. Clean burners as necessary. Make sure that burner heads line up properly to ensure flame crossover. Check spark gap on electrode and adjust if required. The gap should be between 0.110" and 0.140" (3mm to 4mm). The gap may be checked with appropriately sized twist drills or feeler gauges.
 - d. Reinstall burner cluster assembly, burner box top, gas manifold, high tension and sensor leads. Reconnect gas supply piping.
 - e. Restore electrical power and gas supply. Follow lighting instructions to light unit. Check burner flame.

FLUE PASSAGEWAY AND FLUE BOX

The flue passages and flue box should be inspected and cleaned prior to each heating season. The sequence of operation should be as follows:

- 1 - Turn off both electrical and gas supply to unit.
- 2 - Disconnect combustion air inducer wiring.
- 3 - Remove combustion air inducer assembly. Remove flue box. If necessary, remove inducer assembly from flue box. Clean flue box with wire brush.
- 4 - Remove burners as described in "Burners" section.
- 5 - Clean tubes with a wire brush.
- 6 - Reassemble unit. The combustion air and flue box gaskets should also be replaced during reassembly.
- 7 - Restore electrical power and gas supply. Follow lighting instructions to light unit. Check operation of unit.

COMBUSTION AIR INDUCER

Under normal operating conditions, the combustion air inducer should be checked and cleaned prior to the heating season with the power supply disconnected. Use a small brush to clean inducer wheel.

ELECTRICAL

- 1 - Check all wiring for loose connections.
- 2 - Check for correct voltage at unit (unit operating).
- 3 - Check amperage draw.

FLUE AND CHIMNEY

Check all vent and vent connector joints for tightness. Ensure that connections are sealed and that there are no blockages.

REPAIR PARTS

When ordering repair parts, include the complete unit model number listed on the unit rating plate. For example: LS25-125A-1. Contact the installing dealer, or visit www.lennox.com or call 1-800-9LENNOX for a list of the Lennox dealers in the area. Include manufacturer's or distributor's name and address. It is a requirement in the Z83.8 standard.

FAILURE TO OPERATE

If unit fails to operate check the following:

- 1 - Is thermostat calling for heat?
- 2 - Is main disconnect closed?
- 3 - Is there a breaker tripped or a fuse blown?
- 4 - Is gas turned on at meter?
- 5 - Is manual shutoff valve open?
- 6 - Is unit ignition system in lock out? If unit locks out again, call service technician to inspect unit.
- 7 - Is pressure switch closed? Obstructed flue will cause unit to shut off at pressure switch. Check flue passage and outlet.

SAFETY SHUT-OFF VALVE TEST

The safety shut-off valve test procedure is as follows:

- 1 - Turn off the manual gas valve.
- 2 - Set the thermostat to call for heat.
- 3 - System begins normal sequence of operation.
- 4 - After approximately 30 seconds (pre purge period) the LED will fast flash indicating the gas valve is powered.
- 5 - After 10 seconds, the gas valve closes and steps 4 and 5 will repeat two additional times before locking out the gas valve, which will be indicated by two flashes on the LED.
- 6 - To restart the system, de-energize the thermostat call for heat and follow the operating instructions under "Unit Start-Up and Operation."

START-UP AND PERFORMANCE CHECKLIST

Job Name: _____ Job No.: _____ Date: _____

Job Location: _____ City: _____ State/Province: _____

Installer: _____ City: _____ State/Province: _____

Unit Model No.: _____ Serial No.: _____ Service Technician: _____

Electrical Connections Tight? _____ Air Shutters Properly Adjusted (If Installed)? _____

Supply Voltage _____ Flue Connections Tight? _____

Blower Motor Lubrication O.K.? _____ Fan Timer Operation Checked? _____

Gas Piping Connections Tight & Leak-Tested? _____

Blower Motor Amps _____

Furnace Btu Input _____

Line Pressure _____

Manifold Pressure _____ w.c.

THERMOSTAT

Calibrated? _____

Heat Anticipator Properly Set? _____

Level? _____