

INSTALLATION INSTRUCTIONS

⚠️ WARNING

Improper installation, adjustment, alteration, service or maintenance can cause property damage, personal injury or loss of life. Installation and service must be performed by a licensed professional HVAC installer or equivalent, service agency, or the gas supplier

Table Of Contents

Dimensions	Page 2
Parts Arrangements	Page 3
Shipping and Packing List	Page 4
General	Page 4
Safety	Page 4
Unit Support	Page 5
Duct Connection	Page 6
Rigging Unit For Lifting	Page 6
Condensate Drains	Page 6
Gas Piping	Page 8
Pressure Test Gas Piping	Page 9
High Altitude Derate	Page 10
Download Mobile Service App	Page 10
Electrical Connections - Power Supply	Page 10
Electrical Connections - Control Wiring	Page 10
Blower Operation and Adjustments	Page 13
Direct Drive Start-Up	Page 15
Cooling Start-Up	Page 18
Gas Heat Start-Up	Page 24

- LGM092U, LCM092U** (7.5 Ton)
- LGM102U, LCM102U** (8.5 Ton)
- LGM120U, LCM120U** (10 Ton)
- LGM150U, LCM150U** (12.5 Ton)

PACKAGED UNITS
508116-01
1/2021

Prognostic & Diagnostic Sensors	Page 20
Heating Operation and Adjustments	Page 25
Electric Heat Start-Up	Page 25
Cooling Operation	Page 26
Modulating Hot Gas Reheat	Page 27
Service	Page 29
Field-Installed Accessories	Page 35
Unit Controller Parameter Settings	Page 35

⚠️ CAUTION

As with any mechanical equipment, contact with sharp sheet metal edges can result in personal injury. Take care while handling this equipment and wear gloves and protective clothing.

Attention!

Use this QR code to download the mobile service app. Follow the prompts to pair the app with the unit control system and configure the unit. Refer to the “Download Mobile App” section in this manual and the Setup Guide provided with this unit. The QR code is also available in the unit control area.



The app can be downloaded from the appropriate iOS or Android store. Look for the following icon.



LGM/LCM092, 102, 120, & 150 DIMENSIONS - GAS HEAT SECTION SHOWN

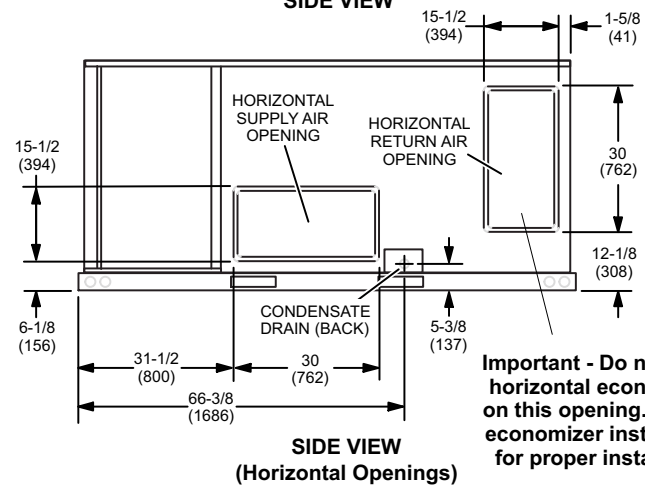
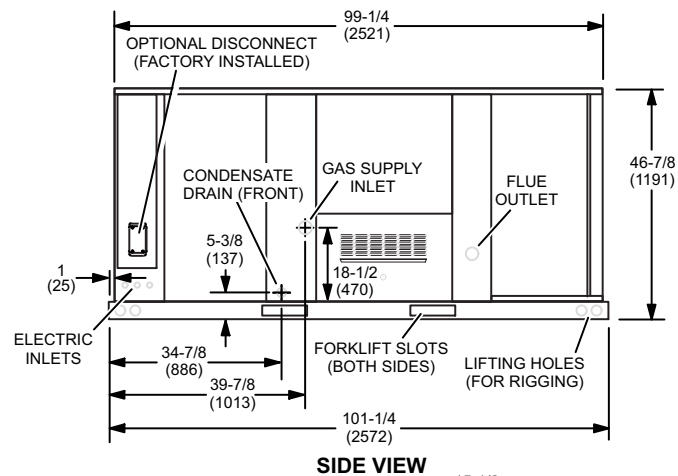
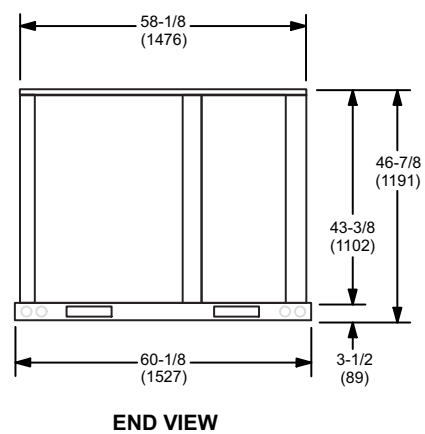
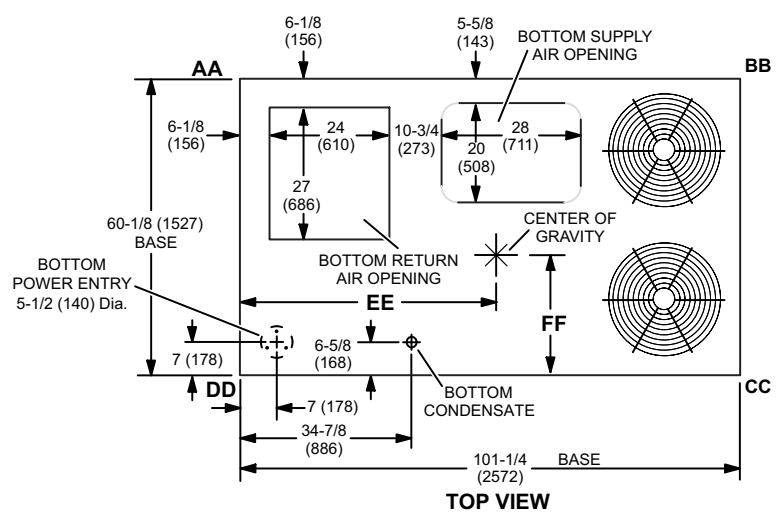

Important - Do not install horizontal economizers on this opening. Refer to economizer instructions for proper installation.

LGM092, 102, 120, 150 PARTS ARRANGEMENT

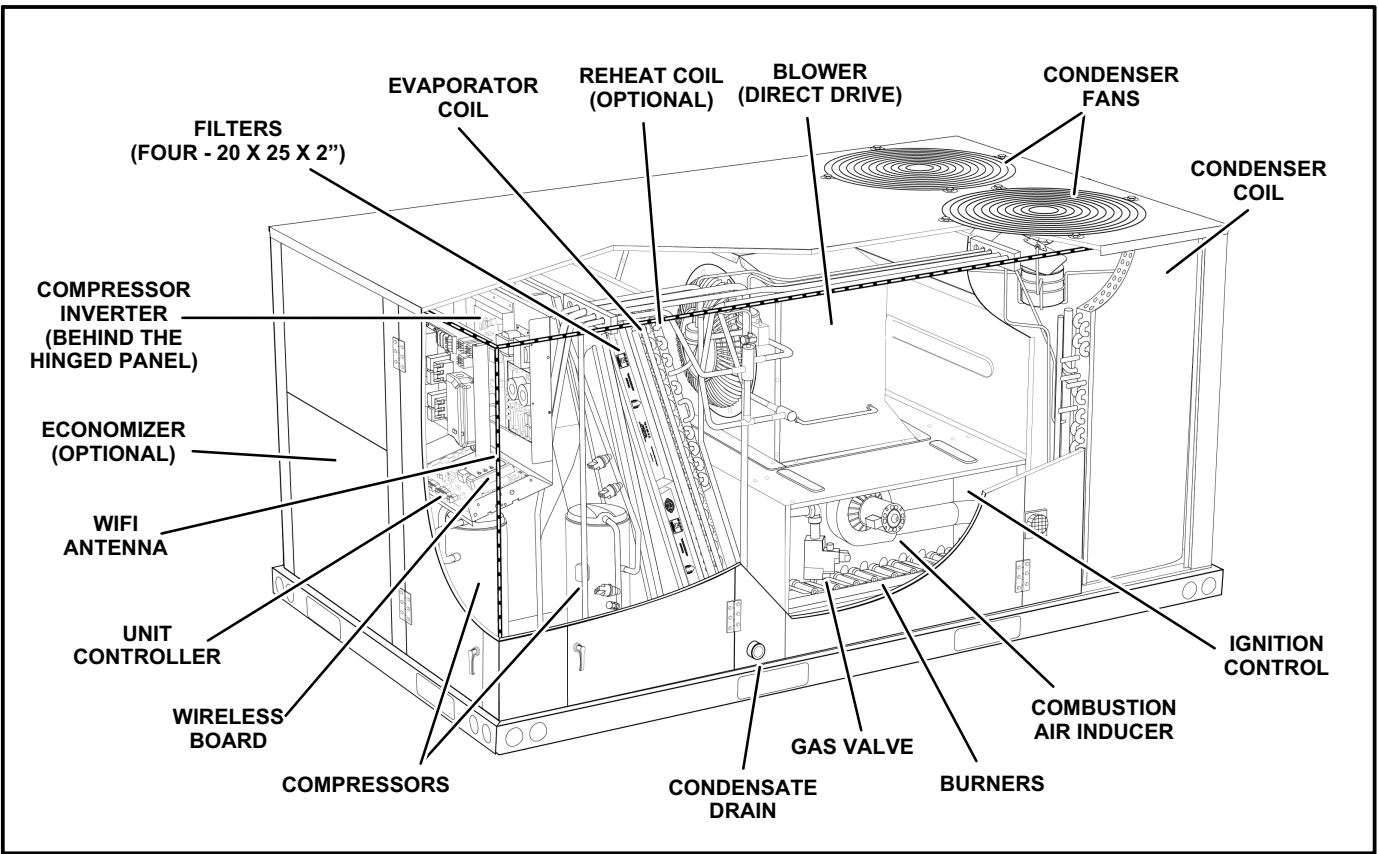

LCM092, 102, 120, 150 PARTS ARRANGEMENT

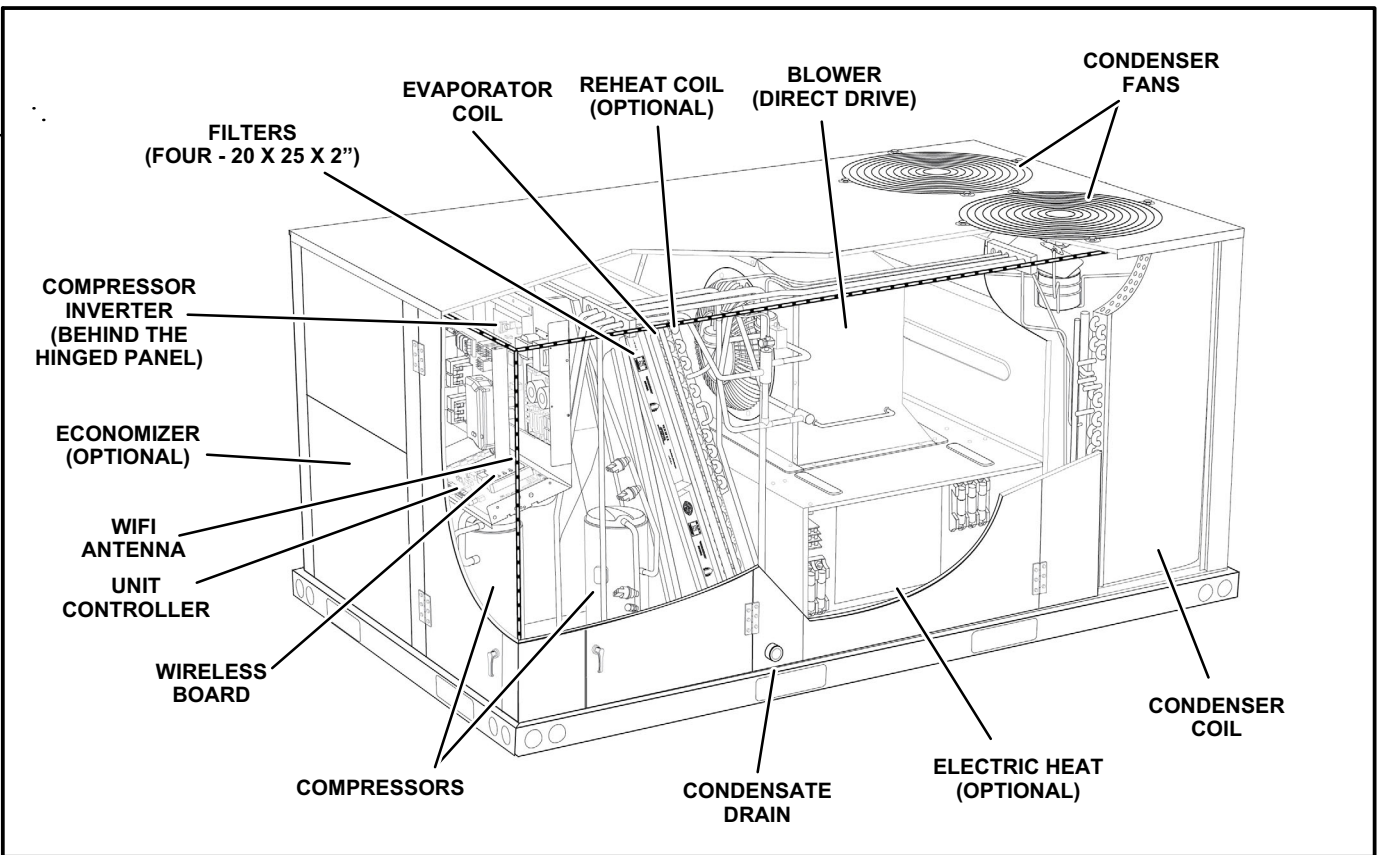

Shipping and Packing List

Package 1 of 1 contains:

1- Assembled unit

Check unit for shipping damage. Receiving party should contact last carrier immediately if shipping damage is found.

General

These instructions are intended as a general guide and do not supersede local codes in any way. Authorities having jurisdiction should be consulted before installation.

The LGM092, 102, 120, & 150 gas/electric packaged rooftop unit is available in 130,000, 180,000, or 240,000 Btuh heating inputs. The LCM092, 102, 120, & 150 cooling packaged rooftop unit is the same basic design as the LGM unit except for the heating section. Optional electric heat is factory- or field-installed in LCM units.

Units are equipped with fin/tube condenser coils.

Units are available with an optional hot gas reheat coil which provides dehumidifying modes of operation. Refer to Reheat Operation section.

Units are equipped with direct drive blowers. The blower will operate at lower speeds when demand is low and increase to higher speeds when demand is high. Refer to the Direct Drive Start-Up section.

The following examples show the model numbers of ten ton units with blower options.

LGM/LCM120U4E Single Zone VAV Direct Drive
 LGM/LCM120U4P VAV Direct Drive

All units are available using R410A, an ozone-friendly HFC refrigerant. Refer to the Cooling Start-Up section for precautions when installing unit.

Safety

See table 1 for unit clearances.

⚠ WARNING



Electric shock hazard and danger of explosion. Can cause injury, death or product or property damage. Turn off gas and electrical power to unit before performing any maintenance or servicing operations on the unit. Follow lighting instructions attached to unit when putting unit back into operation and after service or maintenance.

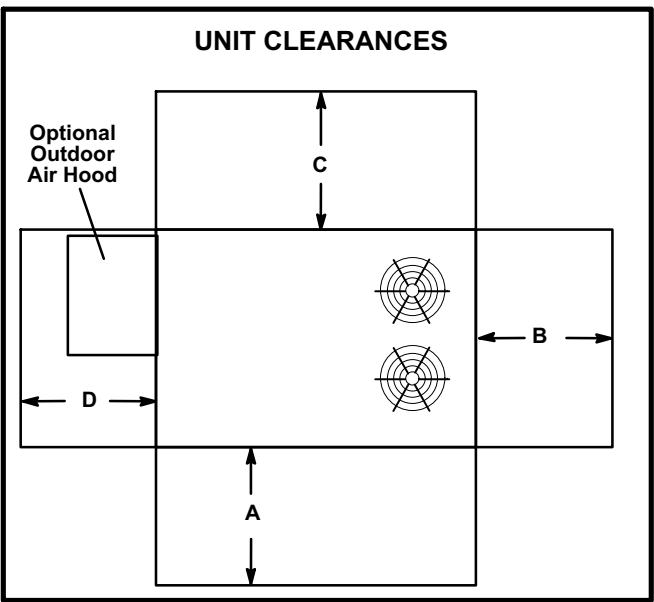

FIGURE 1

TABLE 1
UNIT CLEARANCES

¹ Unit Clearance	A in.(mm)	B in.(mm)	C in.(mm)	D in.(mm)	Top Clearance
Service Clearance	60 (1524)	36 (914)	36 (914)	60 (1524)	Unob- structed
Clearance to Combustibles	36 (914)	1 (25)	1 (25)	1 (25)	Unob- structed
Minimum Operation Clearance	36 (914)	36 (914)	36 (914)	36 (914)	Unob- structed

Note - Entire perimeter of unit base requires support when elevated above mounting surface.

¹ **Service Clearance** - Required for removal of serviceable parts.
Clearance to Combustibles - Required clearance to combustible material (gas units).
Minimum Operation Clearance - Required clearance for proper unit operation.

⚠ NOTICE

Roof Damage!
 This system contains both refrigerant and oil. Some rubber roofing material may absorb oil, causing the rubber to swell. Bubbles in the rubber roofing material can cause leaks. Protect the roof surface to avoid exposure to refrigerant and oil during service and installation. Failure to follow this notice could result in damage to roof surface.

⚠ IMPORTANT

The Clean Air Act of 1990 bans the intentional venting of refrigerant (CFC's and HCFC's) as of July 1, 1992. Approved methods of recovery, recycling or reclaiming must be followed. Fines and/or incarceration may be levied for non-compliance.

Use of this unit as a construction heater or air conditioner is not recommended during any phase of construction. Very low return air temperatures, harmful vapors and operation of the unit with clogged or misplaced filters will damage the unit.

If this unit has been used for heating or cooling of buildings or structures under construction, the following conditions must be met or the warranty will be void:

- A room thermostat or zone air temperature sensor must control the unit. The use of fixed jumpers that will provide continuous heating or cooling is not allowed.
- A pre-filter must be installed at the entry to the return air duct.
- The return air duct must be provided and sealed to the unit.
- Return air temperature range between 55°F (13°C) and 80°F (27°C) must be maintained.
- Air filters must be replaced and pre-filters must be removed upon construction completion.
- The input rate and temperature rise must be set per the unit rating plate.
- The heat exchanger, components, duct system, air filters and evaporator coil must be thoroughly cleaned following final construction clean-up.
- The unit operating conditions (including airflow, cooling operation, ignition, input rate, temperature rise and venting) must be verified according to these installation instructions.

Unit Support

In downflow discharge installations, install the unit on a non-combustible surface only. Unit may be installed on combustible surfaces when used in horizontal discharge applications or in downflow discharge applications when installed on an C1CURB7*B roof mounting frame.

NOTE - Securely fasten roof frame to roof per local codes.

<p>⚠ CAUTION</p> <p>To reduce the likelihood of supply / return air bypass and promote a proper seal with the RTU, duct work / duct drops / diffuser assemblies must be supported independently to the building structure.</p>
--

A-Downflow Discharge Application

Roof Mounting with C1CURB7*B

- 1- The C1CURB7*B roof mounting frame must be installed, flashed and sealed in accordance with the instructions provided with the frame.
- 2- The C1CURB7*B roof mounting frame should be square and level to 1/16" per linear foot (5mm per linear meter) in any direction.
- 3- Duct must be attached to the roof mounting frame and not to the unit; supply and return plenums must be installed before setting the unit.

Installer's Roof Mounting Frame

Many types of roof frames can be used to install the unit depending upon different roof structures. Items to keep in mind when using the building frame or supports are:

- 1- The base is fully enclosed and insulated, so an enclosed frame is not required.
- 2- The frames or supports must be constructed with non-combustible materials and should be square and level to 1/16" per linear foot (5mm per linear meter) in any direction.
- 3- Frame or supports must be high enough to prevent any form of moisture from entering unit. Recommended minimum frame height is 14" (356mm).
- 4- Duct must be attached to the roof mounting frame and not to the unit. Supply and return plenums must be installed before setting the unit.
- 5- Units require support along all four sides of unit base. Supports must be constructed of steel or suitably treated wood materials.

*NOTE-When installing a unit on a combustible surface for downflow discharge applications, an C1CURB7*B roof mounting frame is required.*

B-Horizontal Discharge Applications

- 1- Units installed in horizontal airflow applications must use a horizontal conversion kit K1HECK00.
- 2- Specified installation clearances must be maintained when installing units. Refer to figure 1.
- 3- Top of support slab should be approximately 4" (102mm) above the finished grade and located so no run-off water from higher ground can collect around the unit.
- 4- Units require support along all four sides of unit base. Supports must be constructed of steel or suitably treated wood materials.

Duct Connection

All exterior ducts, joints and openings in roof or building walls must be insulated and weather-proofed with flashing and sealing compounds in accordance with applicable codes. Any duct passing through an unconditioned space must be insulated.

CAUTION

In downflow applications, do not drill or punch holes in base of unit. Leaking in roof may occur if unit base is punctured.

Rigging Unit For Lifting

Rig unit for lifting by attaching four cables to holes in unit base rail. See figure 2.

- 1- Detach wooden base protection before rigging.
Note - Remove all 7 (5 brackets on units with three outdoor fans) base protection brackets before setting unit.
- 2- Connect rigging to the unit base using both holes in each corner.
- 3- All panels must be in place for rigging.
- 4- Place field-provided H-style pick in place just above top edge of unit. Frame must be of adequate strength and length. (H-style pick prevents damage to unit.)

Condensate Drains

Make drain connection to the 1" N.P.T. drain coupling provided on unit.

Note - The drain pan is made with a glass reinforced engineered plastic capable of withstanding typical joint torque but can be damaged with excessive force. Tighten pipe nipple hand tight and turn an additional quarter turn.

A trap must be installed between drain connection and an open vent for proper condensate removal. See figure 3 or 4. It is sometimes acceptable to drain condensate onto the roof or grade; however, a tee should be fitted to the trap to direct condensate downward. The condensate line must be vented. Check local codes concerning condensate disposal. Refer to pages 1 and 2 for condensate drain location.

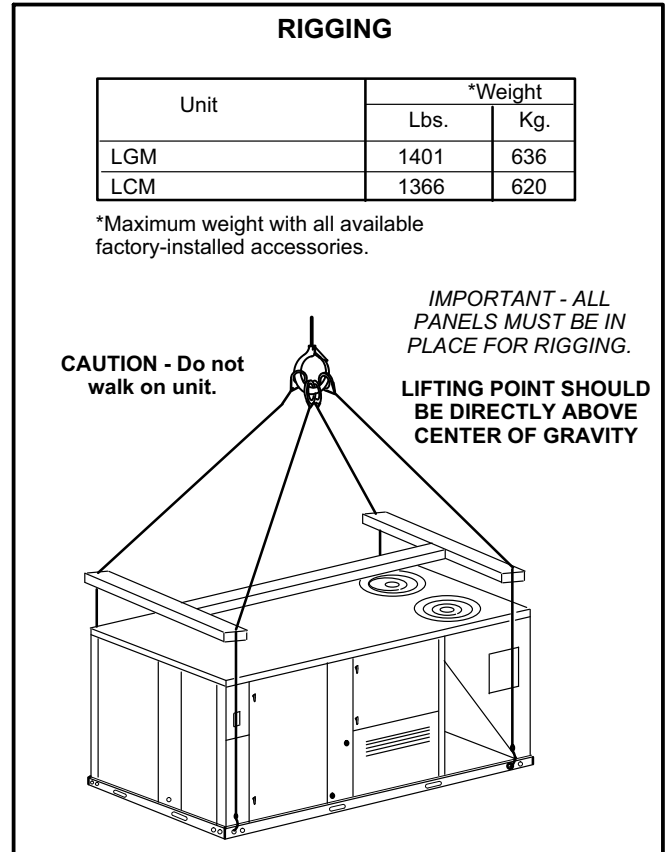

FIGURE 2

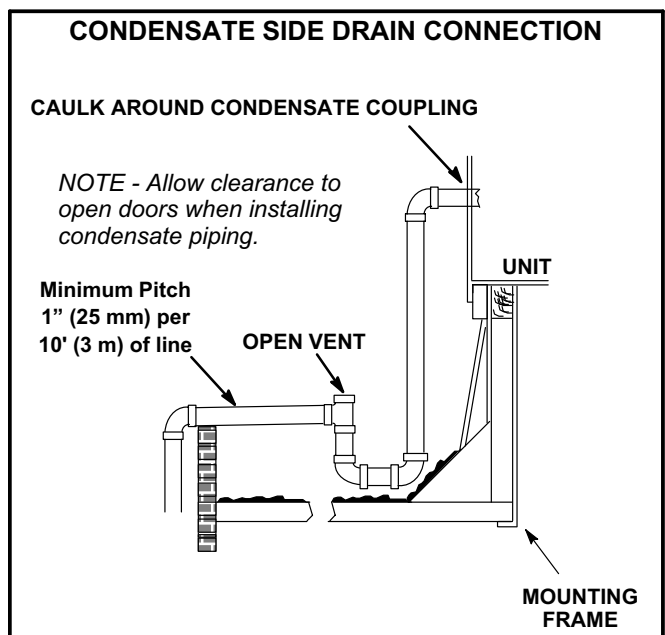

FIGURE 3

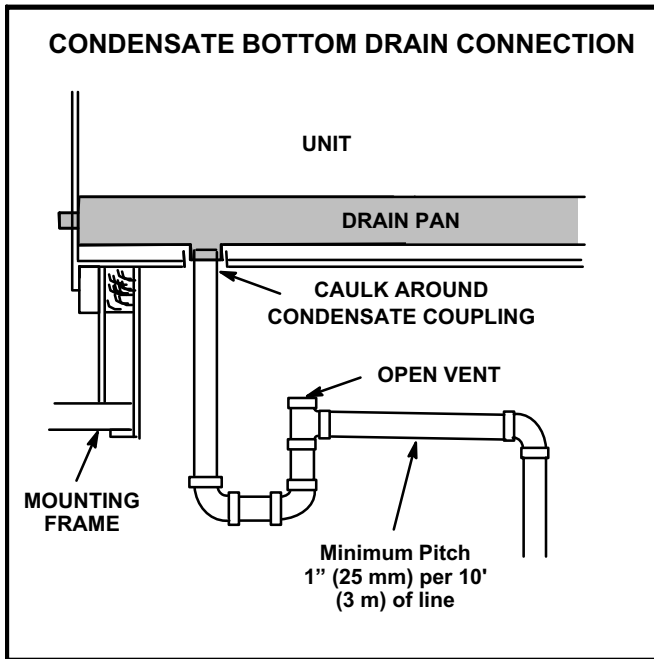

FIGURE 4

Units are shipped with the drain coupling facing the front of the unit. Condensate can be drained from the back or bottom of the unit with the following modifications. The unit can be installed in either downflow or horizontal air discharge regardless of condensate drain location.

Rear Drain Connection

1- Open blower and heat access doors. See figure 5.

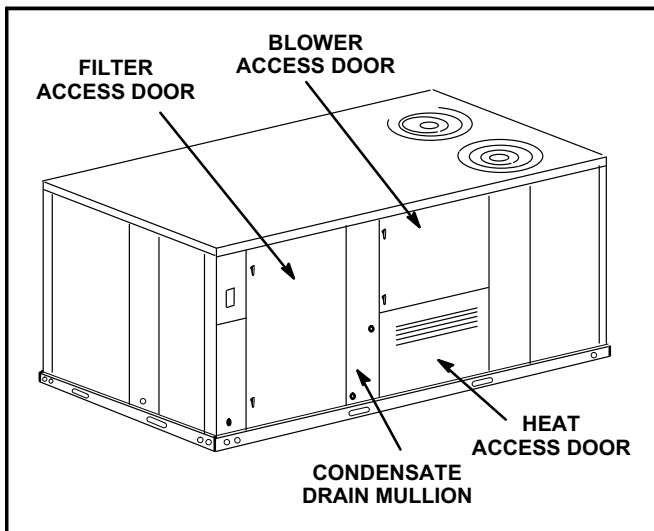

FIGURE 5

2- Remove six screws from filter access door. Refer to figure 6.

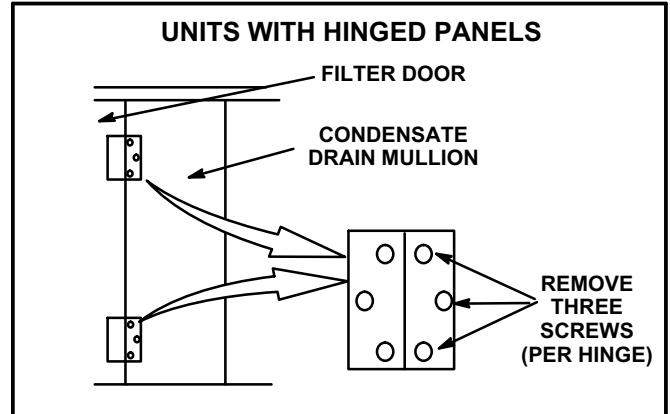

FIGURE 6

- 3- Open filter access door hinges and carefully remove door.
- 4- Remove eight screws holding condensate drain mullion and remove mullion.
- 5- Lift front edge of the drain pan (to clear bottom drain plug) and slide drain pan out of unit. See figure 7.

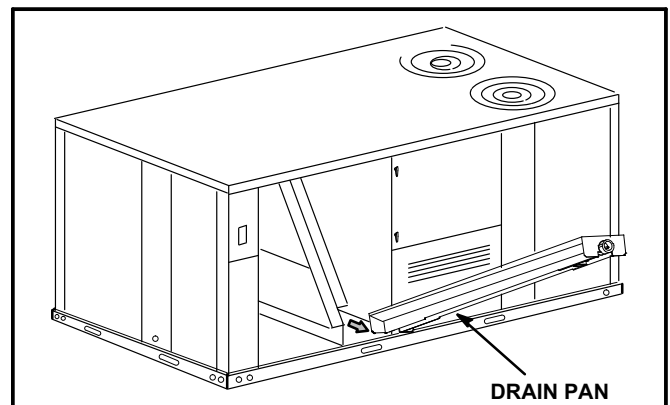

FIGURE 7

- 6- Make sure the cap over the unit bottom drain hole is secure.
- 7- Rotate the drain pan until the downward slope is toward the back of the unit. Slide the drain pan back into the unit. Be careful not to dislodge the cap over the bottom drain hole.
- 8- From the back side of the unit, pull the drain pan coupling through the rear condensate opening.
- 9- Replace the condensate drain mullion and reinstall eight screws.
- 10- Reinstall filter door on hinges.

Bottom Drain Connection

- 1- Open blower and heat access doors. See figure 5.
- 2- Remove six screws from filter access door. Refer to figure 6.
- 3- Open filter access door hinges and carefully remove door.
- 4- Remove eight screws holding condensate drain mullion and remove mullion.
- 5- Lift front edge of the drain pan (to clear bottom drain plug) and slide drain pan out of unit. See figure 7.
- 6- Turn the drain pan upside down and drill a pilot hole through the bottom of the drain pan in the center of the coupling. See figure 8.

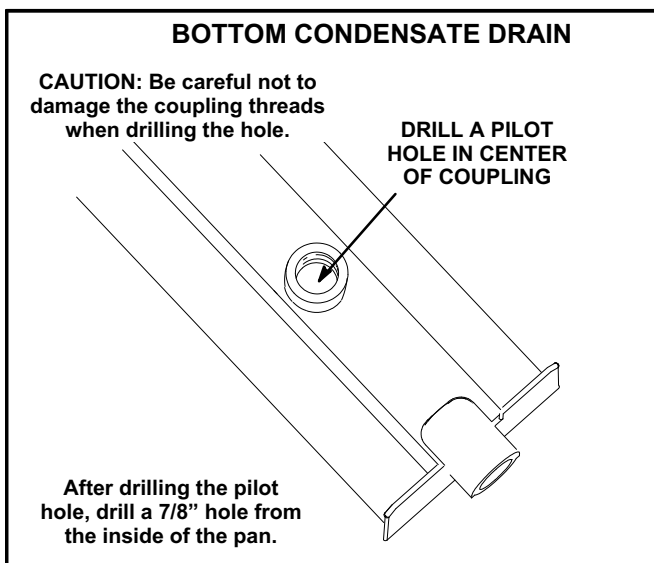

FIGURE 8

- 7- From the inside of the pan, use a Vari-Bit® bit to enlarge the hole to 7/8". Do not damage coupling threads.
- 8- Remove the cap over the unit bottom drain hole.
- 9- Slide the drain pan back into the unit.
- 10- From the back side of the unit, pull the drain pan coupling through the rear condensate opening.
- 11- From the front side of the unit, move the drain pan until the bottom coupling settles into the unit bottom drain opening. Once in place, check to make sure the coupling is still positioned through the rear condensate drain hole.
- 12- Use a field-provided 1" plug to seal side drain connection.
- 13- Replace the condensate drain mullion and reinstall eight screws.
- 14- Reinstall filter door on hinges.

Connect Gas Piping (Gas Units)

Before connecting piping, check with gas company or authorities having jurisdiction for local code requirements. When installing gas supply piping, length of run from gas meter must be considered in determining pipe size for 0.5" w.c. (.12kPa) maximum pressure drop. Do not use supply pipe smaller than unit gas connection. For natural gas units, operating pressure at the unit gas connection must be a minimum of 4.7" w.c. (1.17kPa) and a maximum of 10.5" (2.60kPa) w.c. For LP/propane gas units, operating pressure at the unit gas connection must be a minimum of 10.5" w.c. (2.61kPa) and a maximum of 13.0" w.c. (3.23kPa).

When making piping connections a drip leg should be installed on vertical pipe runs to serve as a trap for sediment or condensate. A 1/8" N.P.T. plugged tap is located on gas valve for test gauge connection. Refer to Heating Start-Up section for tap location. Install a ground joint union between the gas control manifold and the main manual shut-off valve. See figure 9 for gas supply piping entering outside the unit. Figure 10 shows bottom gas entry piping through the curb. Figure 11 shows bottom gas entry piping through the unit.

Compounds used on threaded joints of gas piping shall be resistant to the action of liquified petroleum gases.

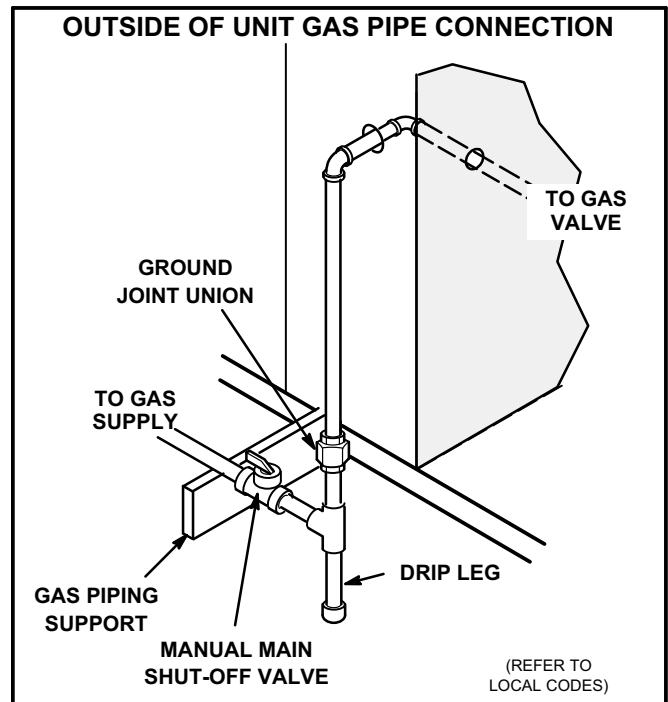

FIGURE 9

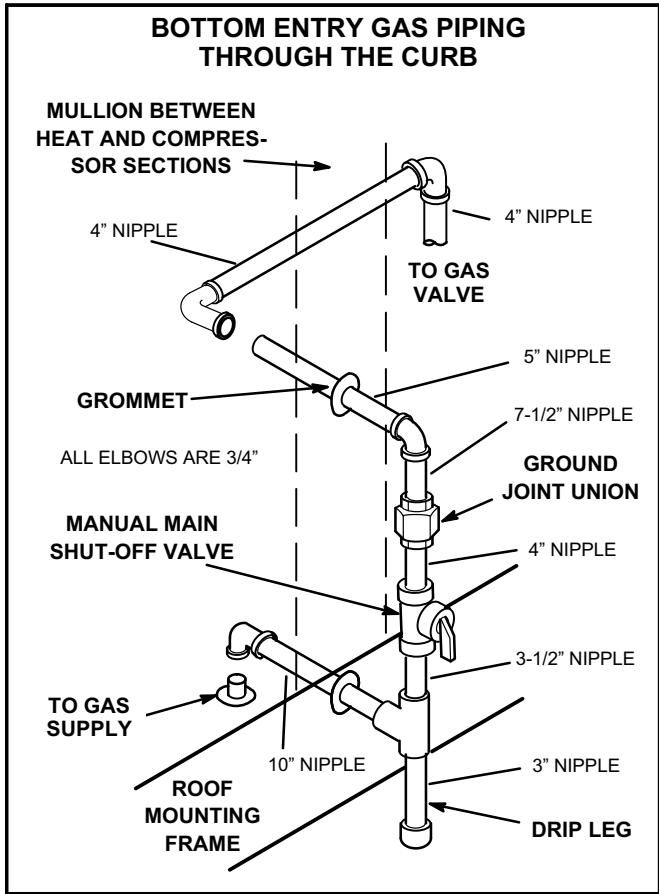

FIGURE 10

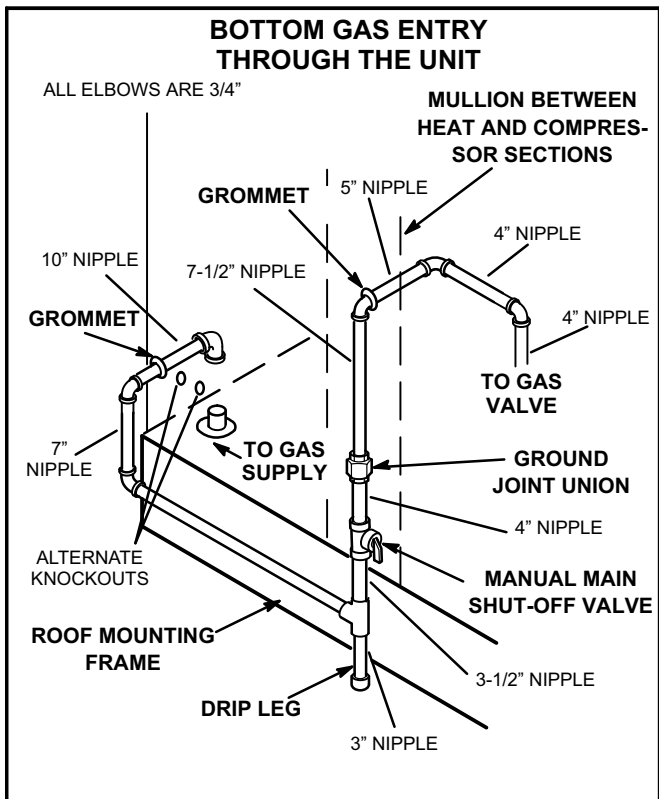

FIGURE 11

Pressure Test Gas Piping (Gas Units)

When pressure testing gas lines, the gas valve must be disconnected and isolated. Gas valves can be damaged if subjected to more than 0.5 psig (3.48kPa). See figure 12.

NOTE-Codes may require that manual main shut-off valve and union (furnished by installer) be installed in gas line external to unit. Union must be of the ground joint type.

After all connections have been made, check all piping connections for gas leaks. Also check existing unit gas connections up to the gas valve; loosening may occur during installation. Use a leak detection solution or other preferred means. Do not use matches candles or other sources of ignition to check for gas leaks.

NOTE-In case emergency shut down is required, turn off the main manual shut-off valve and disconnect main power to unit. These devices should be properly labeled by the installer.

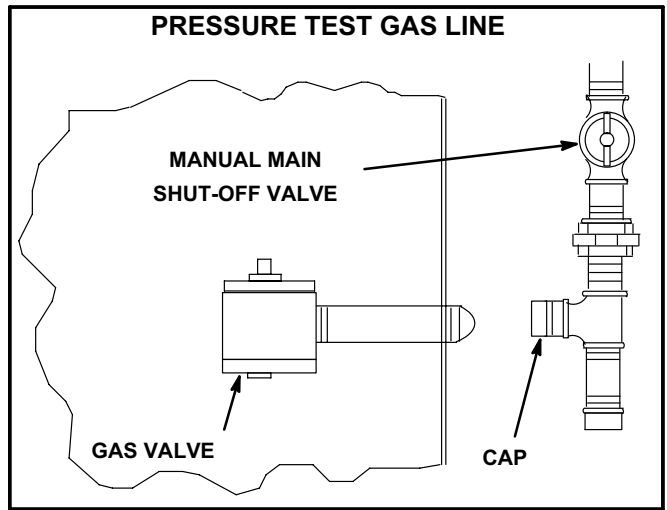

FIGURE 12

⚠ CAUTION

Some soaps used for leak detection are corrosive to certain metals. Carefully rinse piping thoroughly after leak test has been completed. Do not use matches, candles, flame or other sources of ignition to check for gas leaks.

⚠ WARNING



Danger of explosion. Can cause injury or product or property damage. Do not use matches, candles, flame or other sources of ignition to check for leaks.

High Altitude Derate

Locate the high altitude conversion sticker in the unit literature bag. Fill out the conversion sticker and affix next to the unit nameplate.

Refer to table 2 for high altitude adjustments.

**TABLE 2
HIGH ALTITUDE DERATE**

Altitude Ft.*	Gas Manifold Pressure
2000-4500	See Unit Nameplate
4500 And Above	Derate 2% / 1000 Ft. Above Sea Level

*Units installed at 0-2000 feet do not need to be modified.

NOTE - This is the only permissible derate for these units.

Download Mobile Service App

A-Mobile Device Requirements

- Android hardware requires 2GB RAM and a 2Ghz core processor. Tablets are supported.
- Minimum Android 6.0 (Marshmallow) or higher. Recommend Android 10 and Apple products require iOS version 11 or higher.

B-New Installations

Once the app is downloaded, refer to the Setup Guide provided with this unit to pair the app to the unit control system. Follow the setup wizard prompts to configure the unit. See figure 13 for the app menu overview. If a mobile device is unavailable or not pairing, refer to the Unit Controller Setup Guide for start-up instructions.

Electrical Connections - Power Supply

Route field wiring in conduit between bottom power entry disconnect. See figure 14. This does not supersede local codes or authorities having jurisdiction.

Do not apply power or close disconnect switch until installation is complete. Refer to start-up directions. Refer closely to unit wiring diagram.

Refer to unit nameplate for minimum circuit ampacity and maximum fuse size.

- 1- 230/460 volt units are factory wired. **For 208V supply**, disconnect the orange wire (230V) at all control power transformer(s). Reconnect the red wire (208V). Tape the exposed end of the 230V orange wire.
- 2- Route power through the bottom power entry area. On gas units or units with electric heat, connect power wiring to TB2. On cooling only units, connect power to F4. If unit contains an optional factory-installed circuit breaker or disconnect switch, connect line voltage to CB10 or S48. See unit wiring diagram.

- 3- Connect separate 120v wiring to optional GFCI outlet. Route field wiring in conduit between bottom power entry and GFCI. See figure 14.

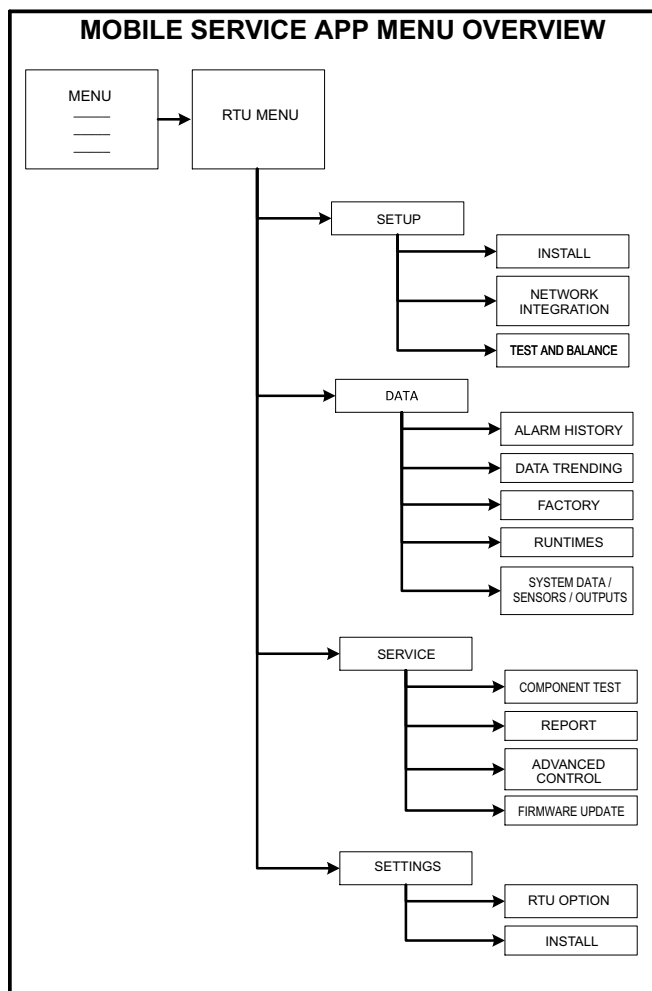

FIGURE 13

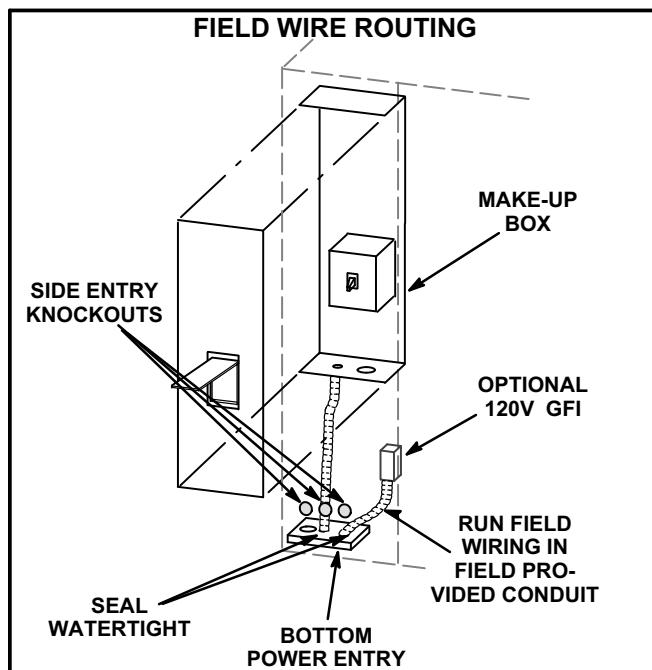

FIGURE 14

Electrical Connections - Control Wiring

NOTE - Optional wireless sensors are available for use with this unit. Refer to the instructions provided with each sensor.

⚠ CAUTION

Electrostatic discharge can affect electronic components. Take precautions during unit installation and service to protect the electronic controls. Precautions will help to avoid control exposure to electrostatic discharge by putting the unit, the control and the technician at the same electrostatic potential. Neutralize electrostatic charge by touching hands and all tools on an unpainted unit surface, such as the gas valve or blower deck, before performing any service procedure.

A-Thermostat Location

Applied to units in default thermostat control mode only. Room thermostat mounts vertically on a standard 2" X 4" handy box or on any non-conductive flat surface.

Locate thermostat approximately 5 feet (1524mm) above the floor in an area with good air circulation at average temperature. Avoid locating the room thermostat where it might be affected by:

- drafts or dead spots behind doors and in corners
- hot or cold air from ducts
- radiant heat from sun or appliances
- concealed pipes and chimneys

B-Control Wiring

The Unit Controller will operate the unit from a thermostat or zone sensor based on the System Mode. The default System Mode is the thermostat mode. Refer to the Unit Controller Setup Guide to change the System Mode. Use the mobile service app menu and select *Settings > Install*.

Thermostat Mode

- 1- Route thermostat cable or wires from subbase to control area above compressor (refer to unit dimensions to locate bottom and side power entry).

IMPORTANT - Unless field thermostat wires are rated for maximum unit voltage, they must be routed away from line voltage wiring. Use wire ties located near the lower left corner of the controls mounting panel to secure thermostat cable.

Use 18 AWG wire for all applications using remotely installed electro-mechanical and electronic thermostats.

- 2- Install thermostat assembly in accordance with instructions provided with thermostat.

- 3- Connect thermostat wiring to Unit Controller on the lower side of the controls hat section.
- 4- Wire as shown in figure 15 for electro-mechanical and electronic thermostats. If using other temperature control devices or energy management systems see instructions and wiring diagram provided by manufacturer.

IMPORTANT - Terminal connections at the Unit Controller must be made securely. Loose control wire connections may allow unit to operate but not with proper response to room demand.

Zone Sensor Mode

The Unit Controller will operate heating and cooling based on the Unit Controller internal setpoints and the temperature from the A2 room sensor. An optional Network Control Panel (NCP) can also be used to provide setpoints. A thermostat or return air sensor can be used as a back-up mode. Make room sensor wiring connections as shown in figure 16.

C-Hot Gas Reheat Units Only -

- 1- Install humidity sensor in accordance with instructions provided with sensor. A DDC input may be used to initiate dehumidification instead of a sensor.
- 2- Make wiring connections as shown in figure 15 for Thermostat Mode or figure 16 for Zone Sensor Mode. In addition, connect either a humidity sensor or a dehumidification input. See figure 18 or 19 for humidity sensor wiring or figure 17 for dehumidification input wiring.

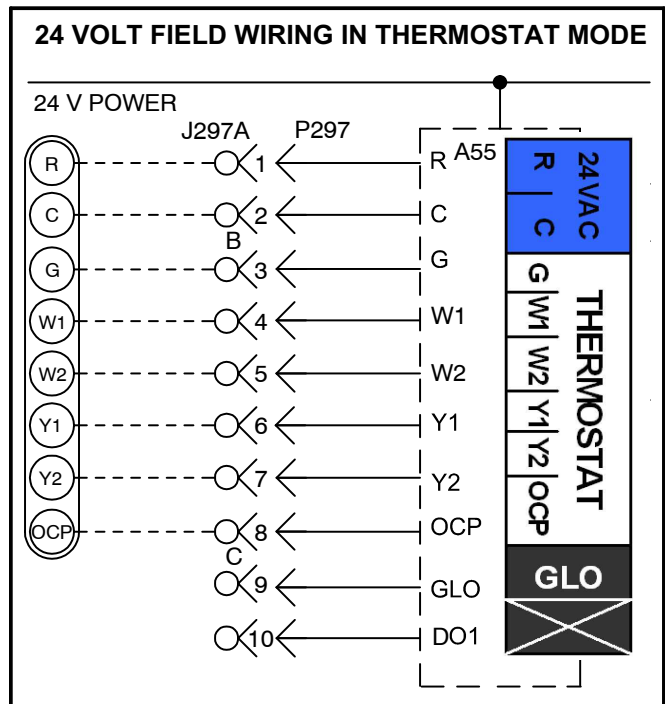

FIGURE 15

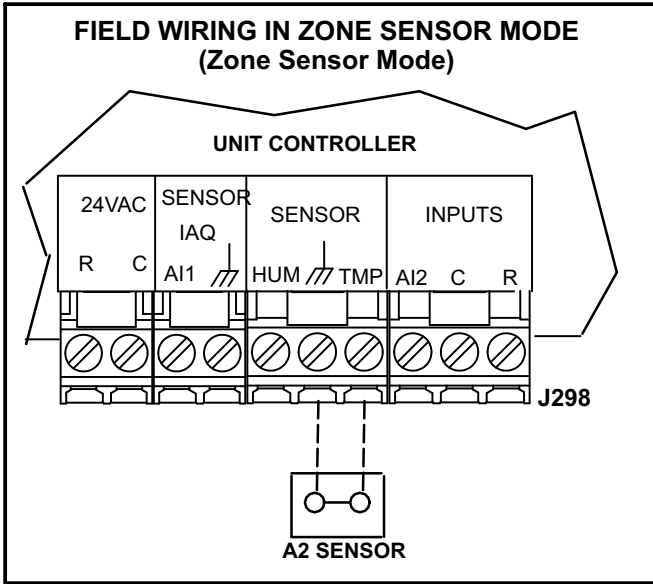

FIGURE 16

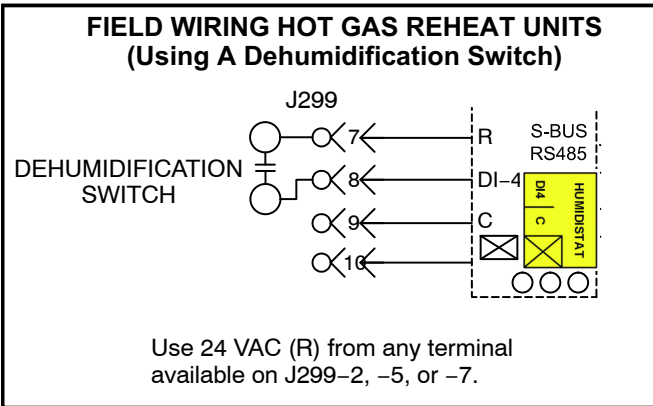

FIGURE 17

Humidity Sensor Cable Applications:

Wire runs of 50 feet (mm) or less:

Use two separate shielded cables containing 20AWG minimum, twisted pair conductors with overall shield. Belden type 8762 or 88760 (plenum) or equivalent. Connect both cable shield drain wires to the Unit Controller as shown in figure 18.

Wire runs of 150 feet (mm) or less:

Use two separate shielded cables containing 18AWG minimum, twisted pair conductors with overall shield. Belden type 8760 or 88760 (plenum) or equivalent. Connect both cable shield drain wires to the Unit Controller as shown in figure 18.

Wire runs over 150 feet (mm):

Use a local, isolated 24VAC transformer such as Lennox cat #18M13 (20VA minimum) to supply power to RH sensor as shown in figure 19. Use two shielded cables containing 20AWG minimum, twisted pair conductors with overall shield. Belden type 8762 or 88760 (plenum) or equivalent.

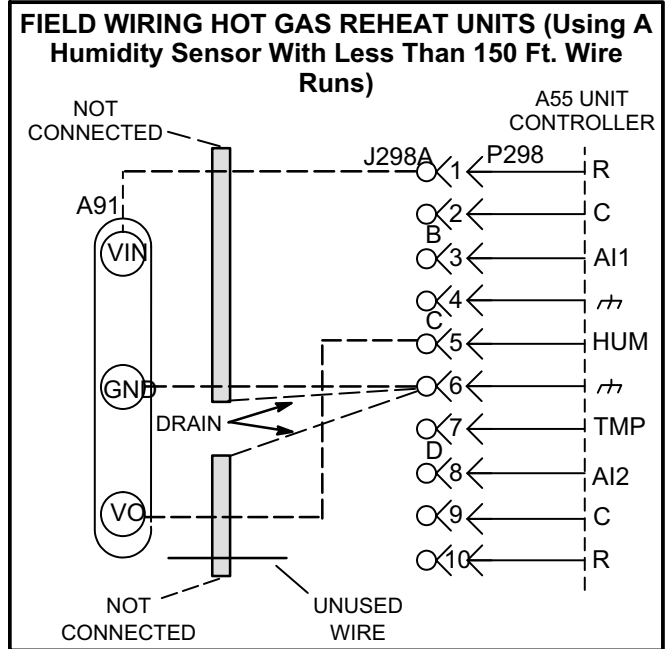

FIGURE 18

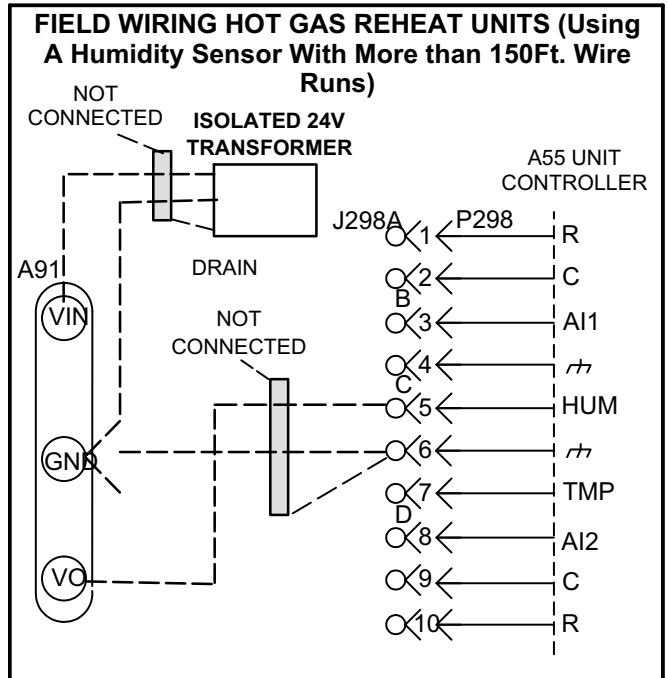

FIGURE 19

Blower Operation

Units are equipped with variable speed, direct drive blowers. The installer is able to enter the design-specified supply air CFM into the Unit Controller for optimal efficiency. The Unit Controller calibrates the supply air volume which eliminates the need to manually take duct static measurements. Refer to *C-Adjusting Unit CFM - Ultra High Efficiency Direct Drive Blowers*.

⚠ IMPORTANT

Compressor two is the only component that must be checked to ensure proper phasing. Follow "COOLING START-UP" section of installation instructions to ensure proper compressor and blower operation.

The Unit Controller checks the incoming power during start-up. If the voltage or phase is incorrect, the Unit Controller will display an alarm and the unit will not start.

A-Blower Operation

Refer to the Unit Controller Setup Guide to energize blower. Use the mobile service app menu; see *SERVICE > TEST*.

In thermostat control mode, the Unit Controller will stage the blower between low and high speed. In zone sensor control mode, the Unit Controller will vary (VAV) the blower between low and high speed.

⚠ WARNING

1-Make sure that unit is installed in accordance with the installation instructions and applicable codes.

2-Inspect all electrical wiring, both field- and factory-installed, for loose connections. Tighten as required.

3-Check to ensure that refrigerant lines do not rub against the cabinet or against other refrigerant lines.

4-Check voltage at disconnect switch. Voltage must be within range listed on nameplate. If not, consult power company and have voltage condition corrected before starting unit.

5-Make sure filters are new and in place before start-up.

Initiate blower only (G) demand at thermostat according to instructions provided with thermostat. Unit will cycle on thermostat demand. The following steps apply to applications using a typical electro-mechanical thermostat.

- 1- Blower operation is manually set at the thermostat subbase fan switch. With fan switch in **ON** position, blowers will operate continuously.
- 2- With fan switch in **AUTO** position, the blowers will cycle with demand. Blowers and entire unit will be off when system switch is in **OFF** position.

NOTE - Blower operation mode can also be initiated by the mobile service app.

B-Blower Access

The blower assembly is secured to a sliding frame which allows the blower assembly to be pulled out of the unit. See figure 21.

- 1- Loosen the reusable wire tie which secures the controls and high voltage blower wiring to the blower housing. Disconnect the pressure sensor low voltage wire harness.
- 2- Remove and retain screws on either side (and on the front for direct drive) of sliding frame. Use the metal handle to pull frame toward outside of unit.
- 3- Slide frame back into original position when finished servicing. Reattach the blower wiring in the previous location using the wire tie. Reconnect pressure sensor low voltage wire harness.
- 4- Replace retained screws.

LOCATION OF STATIC PRESSURE READINGS

INSTALLATIONS WITH DUCTWORK

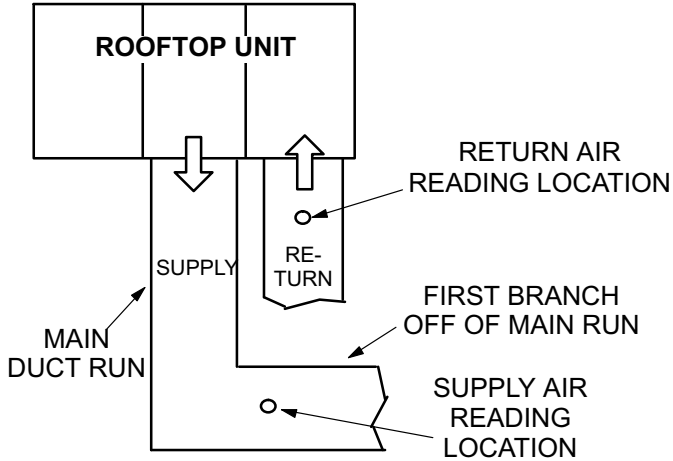

INSTALLATIONS WITH CEILING DIFFUSERS

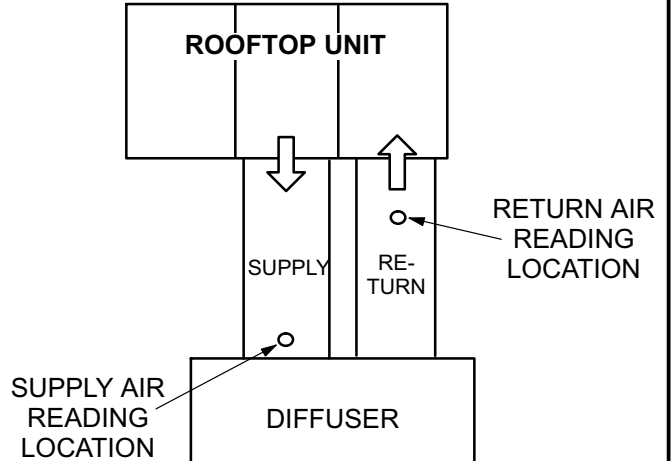

FIGURE 20

DIRECT DRIVE BLOWER ASSEMBLY

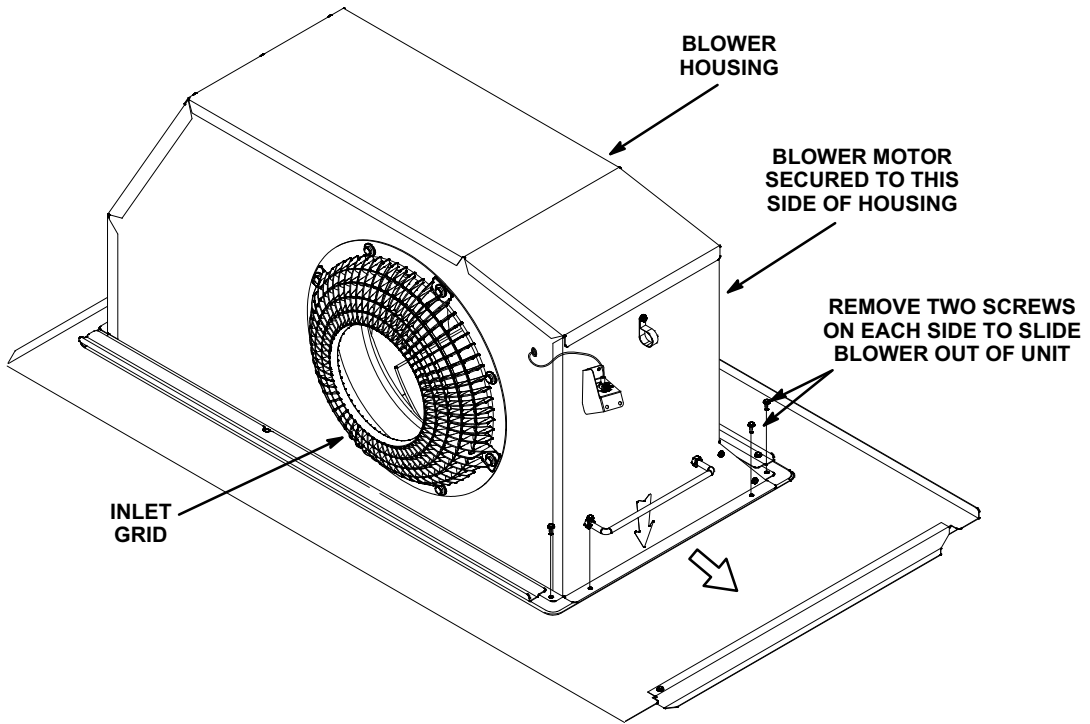

FIGURE 21

Direct Drive Blower Start-Up

The supply CFM can be adjusted by changing Unit Controller settings. Refer to table 3 for menu paths and default settings. Record any CFM changes on the parameter settings label located on the inside of the compressor access panel.

CAUTION

The BLOWER CALIBRATION process starts the indoor blower at operational speeds and moves the economizer damper blades. Before starting this process, replace any access panels and close all unit doors except compressor compartment door.

Blower calibration is required only on units that are newly installed or if there is a change in the duct work or air filters after installation. Use the mobile service app to navigate to the SETUP>TEST & BALANCE>BLOWER menu. After the new CFM values are entered, select START CALIBRATION. The blower calibration status is displayed as a % complete. Upon successful completion, the mobile service app will display CALIBRATION SUCCESS and go back to the blower calibration screen.

IMPORTANT - The default value for Cooling Low CFM is lower than a traditional single- or two-speed unit. If operating the unit with a 2- or 3-stage controller (2- or 3-stage thermostat, DDC controller, etc.), it is recommended to increase the Cooling Low CFM default value to a suitable level for part load cooling (typically 60% of full load CFM).

**TABLE 3
DIRECT DRIVE PARAMETER SETTINGS**

Parameter	Factory Setting				Field Setting	Description
	092	102	120	150		
Note: Any changes to Smoke CFM setting must be adjusted before the other CFM settings. Use SETTINGS > RTU OPTIONS > EDIT PARAMETERS = 12						
BLOWER SMOKE CFM	3000	3400	4000	5000	CFM	Smoke blower speed
SETUP > TEST & BALANCE > BLOWER						
BLOWER HEATING HIGH CFM	3000	3400	4000	5000	CFM	Heating blower speed
BLOWER COOLING HIGH CFM	2625	2975	3500	4375	CFM	High cooling blower speed
BLOWER COOLING LOW CFM	800	800	875	1100	CFM	Low cooling blower speed
BLOWER VENTILATION CFM	800	800	875	1100	CFM	Ventilation blower speed
SETUP > TEST & BALANCE > DAMPER						
BLOWER HIGH CFM DAMPER POS %	0%	0%	0%	0%	%	Minimum damper position for high speed blower operation.
BLOWER LOW CFM DAMPER POS %	0%	0%	0%	0%	%	Minimum damper position for low speed blower operation.
POWER EXHAUST DAMPER POS %	50%	50%	50%	50%	%	Minimum damper position for power exhaust operation.
SETTINGS > RTU OPTIONS > EDIT PARAMETERS = 216						
POWER EXHAUST DEADBAND %	10%	10%	10%	10%	%	Deadband % for power exhaust operation.
SETTINGS > RTU OPTIONS > EDIT PARAMETER = 10 (Applies to Thermostat Mode ONLY)						
FREE COOLING STAGE-UP DELAY	300 sec.	300 sec.	300 sec.	300 sec.	sec	Number of seconds to hold indoor blower at low speed before switching to indoor blower at high speed.

Installer: Circle applicable unit model number and record any parameter changes under "Field Setting" column. Settings need to be recorded by installer for use when Unit Controller is replaced or reprogrammed.

BLOWER DATA

BLOWER TABLE INCLUDES RESISTANCE FOR BASE UNIT ONLY (NO HEAT SECTION) WITH DRY INDOOR COIL AND AIR FILTERS IN PLACE.

FOR ALL UNITS ADD:

- 1 – Wet indoor coil air resistance of selected unit.
 - 2 – Any factory installed options air resistance (heat section, Economizer, etc.)
 - 3 – Any field installed accessories air resistance (duct resistance, diffuser, etc.)
- See page 17 for wet coil and option/accessory air resistance data.

MAXIMUM STATIC PRESSURE WITH GAS HEAT - 2.0 in. w.g.

MINIMUM AIR VOLUME REQUIRED FOR USE WITH OPTIONAL ELECTRIC HEAT (Maximum Static Pressure - 2.0 in. w.g.)

092, 102 Models - 7.5 kW - 1750 cfm

All Models - 15 kW, 22.5 kW, 30 kW, 45 kW - 2750 cfm

120, 150 Models - 60 kW - 3500 cfm

Total Air Volume cfm	Total Static Pressure - in. w.g.													
	0.2		0.4		0.6		0.8		1.0		1.2		1.4	
	RPM	Watts	RPM	Watts	RPM	Watts	RPM	Watts	RPM	Watts	RPM	Watts	RPM	Watts
1750	711	188	771	279	836	366	905	453	975	544	1044	640	1109	737
2000	752	242	812	332	876	420	944	510	1011	606	1075	709	1138	812
2250	799	300	860	389	923	479	988	575	1052	678	1113	787	1171	896
2500	853	362	914	453	976	548	1038	650	1097	761	1154	877	1209	990
2750	914	434	974	529	1033	629	1091	739	1146	858	1199	979	1250	1098
3000	980	513	1037	614	1092	720	1146	837	1198	961	1247	1088	1295	1215
3250	1048	598	1101	705	1153	819	1203	941	1251	1071	1298	1206	1343	1343
3500	1116	693	1166	809	1214	931	1261	1060	1307	1198	1351	1341	1395	1489
3750	1185	806	1232	931	1277	1063	1322	1201	1365	1348	1407	1499	1448	1657
4000	1254	937	1299	1072	1341	1214	1383	1363	1424	1518	1464	1679	1503	1844
4250	1324	1089	1366	1234	1406	1386	1445	1545	1484	1708	1522	1876	1559	2046
4500	1395	1262	1433	1417	1471	1579	1508	1745	1544	1913	1581	2084	1616	2256
4750	1465	1455	1501	1619	1536	1787	1571	1957	1606	2128	1641	2299	1675	2470
5000	1534	1666	1568	1834	1602	2004	1635	2174	1668	2345	1701	2514	1735	2682
5250	1603	1887	1635	2055	1667	2224	1699	2392	1731	2559	1763	2724	---	---
5500	1671	2110	1702	2275	1733	2441	1764	2605	---	---	---	---	---	---
5750	1738	2325	1768	2488	---	---	---	---	---	---	---	---	---	---

Total Air Volume cfm	Total Static Pressure - in. w.g.											
	1.6		1.8		2.0		2.2		2.4		2.6	
	RPM	Watts	RPM	Watts	RPM	Watts	RPM	Watts	RPM	Watts	RPM	Watts
1750	1172	833	1231	932	1287	1039	1340	1156	1391	1283	1442	1426
2000	1197	913	1253	1019	1306	1135	1357	1261	1407	1398	1457	1547
2250	1227	1003	1280	1117	1330	1242	1379	1378	1428	1525	1477	1680
2500	1261	1103	1311	1226	1360	1361	1407	1507	1454	1663	1501	1826
2750	1299	1219	1347	1350	1394	1494	1440	1649	1485	1813	1530	1982
3000	1342	1346	1388	1487	1432	1640	1476	1803	1520	1973	1563	2146
3250	1388	1485	1432	1638	1475	1800	1517	1969	1558	2143	1600	2319
3500	1437	1643	1479	1805	1519	1975	1560	2148	1600	2325	1640	2502
3750	1489	1821	1528	1990	1567	2164	1605	2340	1645	2517	1685	2693
4000	1541	2014	1579	2187	1616	2364	1654	2540	1693	2715	1732	2887
4250	1596	2218	1632	2393	1668	2569	1705	2742	1743	2913	---	---
4500	1652	2429	1687	2603	1722	2775	1759	2944	---	---	---	---
4750	1709	2641	1743	2811	1778	2979	---	---	---	---	---	---
5000	1768	2850	---	---	---	---	---	---	---	---	---	---
5250	---	---	---	---	---	---	---	---	---	---	---	---
5500	---	---	---	---	---	---	---	---	---	---	---	---
5750	---	---	---	---	---	---	---	---	---	---	---	---

BLOWER DATA

POWER EXHAUST FAN PERFORMANCE

Return Air System Static Pressure	Air Volume Exhausted
in. w.g.	cfm
0	3175
0.05	2955
0.10	2685
0.15	2410
0.20	2165
0.25	1920
0.30	1420
0.35	1200

FACTORY INSTALLED OPTIONS/FIELD INSTALLED ACCESSORY AIR RESISTANCE - in. w.g.

Air Volume cfm	Wet Indoor Coil	Gas Heat Exchanger			Electric Heat	Econo- mizer	Humiditrol + Condenser Reheat Coil	Filters			Return Air Adaptor Plate
		Standard Heat	Medium Heat	High Heat				MERV 8	MERV 13	MERV 16	
1750	0.04	0.06	0.02	0.02	0.03	0.05	0.02	0.01	0.03	0.05	0.00
2000	0.05	0.07	0.05	0.06	0.03	0.06	0.02	0.01	0.03	0.06	0.00
2250	0.06	0.07	0.07	0.08	0.04	0.08	0.02	0.01	0.04	0.07	0.00
2500	0.07	0.09	0.10	0.11	0.04	0.11	0.03	0.01	0.05	0.08	0.00
2750	0.08	0.09	0.11	0.12	0.05	0.12	0.03	0.02	0.05	0.09	0.00
3000	0.09	0.11	0.12	0.13	0.06	0.13	0.03	0.02	0.06	0.10	0.02
3250	0.10	0.12	0.15	0.16	0.06	0.15	0.04	0.02	0.06	0.11	0.02
3500	0.11	0.12	0.16	0.17	0.09	0.15	0.04	0.03	0.07	0.12	0.04
3750	0.13	0.14	0.19	0.20	0.09	0.15	0.05	0.03	0.08	0.13	0.07
4000	0.14	0.14	0.21	0.22	0.09	0.19	0.05	0.04	0.08	0.14	0.09
4250	0.15	0.14	0.24	0.28	0.13	0.19	0.06	0.04	0.09	0.15	0.11
4500	0.17	0.15	0.26	0.32	0.14	0.22	0.07	0.04	0.09	0.17	0.12
4750	0.18	0.16	0.29	0.37	0.17	0.25	0.07	0.05	0.10	0.18	0.16
5000	0.20	0.16	0.34	0.43	0.20	0.29	0.08	0.06	0.10	0.19	0.18
5250	0.22	0.16	0.37	0.47	0.22	0.32	0.08	0.06	0.11	0.20	0.19
5500	0.23	0.18	0.44	0.54	0.25	0.34	0.09	0.07	0.12	0.22	0.22
5750	0.25	0.19	0.49	0.59	0.31	0.45	0.10	0.07	0.12	0.23	0.25
6000	0.27	0.20	0.54	0.64	0.33	0.52	0.10	0.08	0.13	0.24	0.27

Cooling Start-Up

IMPORTANT-The crankcase heater must be energized for 24 hours before attempting to start compressor. Set thermostat so there is no demand to prevent compressors from cycling. Apply power to unit.

A-Start-Up

- 1- Initiate full load cooling operation using the following mobile service app menu path:
RTU MENU > SERVICE > COMPONENT TEST > COOLING > COOL 4
- 2- Refer to Cooling Operation section for cooling start-up.
- 3- Units have two refrigerant circuits. See figure 22.
- 4- Each refrigerant circuit is charged with R410A refrigerant. See unit rating plate for correct amount of charge.
- 5- Refer to Refrigerant Check and Charge section for proper method to check refrigerant charge.

B-R410A Refrigerant

Units charged with R410A refrigerant operate at much higher pressures than R22. The expansion valve and liquid line drier provided with the unit are approved for use with R410A. Do not replace them with components designed for use with R22.

R410A refrigerant is stored in a pink cylinder.

Manifold gauge sets used with systems charged with R410A refrigerant must be capable of handling the higher system operating pressures. The gauges should be rated for use with pressures of 0-800 on the high side and a low side of 30" vacuum to 250 psi with dampened speed to 500 psi. Gauge hoses must be rated for use at up to 800 psi of pressure with a 4000 psi burst rating.

▲ IMPORTANT

Mineral oils are not compatible with R410A. If oil must be added, it must be a polyol ester oil.

C-Refrigerant Charge and Check

WARNING-Do not exceed nameplate charge under any condition.

This unit is factory charged and should require no further adjustment. If the system requires additional refrigerant, reclaim the charge, evacuate the system, and add required nameplate charge.

NOTE - System charging is not recommended below 60°F (15°C). In temperatures below 60°F (15°C), the charge **must** be weighed into the system.

If weighing facilities are not available, or to check the charge, use the following procedure:

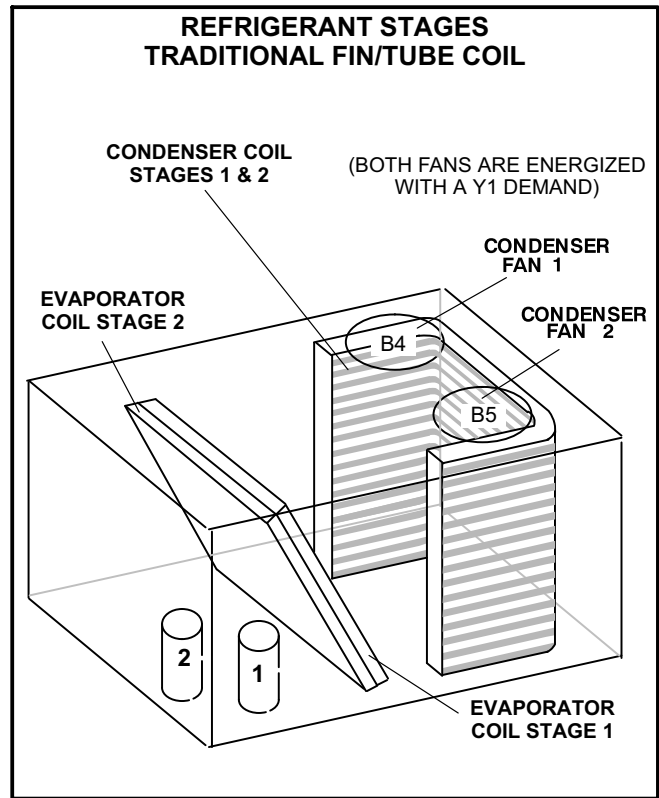

FIGURE 22

- 1- Attach gauge manifolds to discharge and suction lines. With the economizer disabled, operate the unit in **cooling mode at high speed** using the following mobile service app menu path:
SERVICE > COMPONENT TEST > COOLING > COOL 4
- 2- Use a thermometer to accurately measure the outdoor ambient temperature.
- 3- Apply the outdoor temperature to tables 4 through 11 to determine normal operating pressures. Pressures are listed for sea level applications at 80°F dry bulb and 67°F wet bulb return air.
- 4- Compare the normal operating pressures to the pressures obtained from the gauges. Minor variations in these pressures may be expected due to differences in installations. Significant differences could mean that the system is not properly charged or that a problem exists with some component in the system. **Correct any system problems before proceeding.**
- 5- If discharge pressure is high, remove refrigerant from the system. If discharge pressure is low, add refrigerant to the system.
 - Add or remove charge in increments.
 - Allow the system to stabilize each time refrigerant is added or removed.
- 6- Use the following subcooling method along with the normal operating pressures to confirm readings.

**TABLE 4 581027-01
LGM/LCM092U No Reheat**

Outdoor Coil Entering Air Temp	CIRCUIT 1		CIRCUIT 2	
	Dis-charge ±10 psig	Suction ±5 psig	Dis-charge ±10 psig	Suction ±5 psig
65° F	252	140	269	137
75° F	293	143	311	139
85° F	335	146	354	142
95° F	382	148	403	144
105° F	434	150	454	147
115° F	490	153	508	150

**TABLE 5 581028-01
LGM/LCM092U Reheat**

Outdoor Coil Entering Air Temp	Circuit 1		Circuit 2	
	Dis-charge ±10 psig	Suction ±5 psig	Dis-charge ±10 psig	Suction ±5 psig
65° F	258	140	269	136
75° F	301	139	308	137
85° F	344	141	349	139
95° F	392	143	398	142
105° F	445	145	447	144
115° F	504	148	501	147

**TABLE 6 581029-01
LGM/LCM102U No Reheat**

Outdoor Coil Entering Air Temp	Circuit 1		Circuit 2	
	Dis-charge ±10 psig	Suction ±5 psig	Dis-charge ±10 psig	Suction ±5 psig
65° F	256	140	259	139
75° F	294	143	300	141
85° F	333	147	341	143
95° F	381	149	388	146
105° F	433	151	438	149
115° F	487	155	491	153

**TABLE 7 581030-01
LGM/LCM102U Reheat**

Outdoor Coil Entering Air Temp	Circuit 1		Circuit 2	
	Dis-charge ±10 psig	Suction ±5 psig	Dis-charge ±10 psig	Suction ±5 psig
65° F	264	140	266	137
75° F	301	139	300	139
85° F	349	141	341	141
95° F	399	144	390	144
105° F	450	146	440	147
115° F	508	149	494	150

**TABLE 8 581031-01
LGM/LCM120U No Reheat**

Outdoor Coil Entering Air Temp	Circuit 1		Circuit 2	
	Dis-charge ±10 psig	Suction ±5 psig	Dis-charge ±10 psig	Suction ±5 psig
65° F	258	132	263	131
75° F	296	137	302	133
85° F	337	139	344	135
95° F	383	141	389	137
105° F	439	142	438	140
115° F	490	145	494	143

**TABLE 9 581032-01
LGM/LCM120U Reheat**

Outdoor Coil Entering Air Temp	Circuit 1		Circuit 2	
	Dis-charge ±10 psig	Suction ±5 psig	Dis-charge ±10 psig	Suction ±5 psig
65° F	272	131	255	133
75° F	309	135	294	135
85° F	350	138	335	137
95° F	396	139	381	139
105° F	452	141	430	142
115° F	503	144	485	145

**TABLE 10 581033-01
LGM/LCM150U No Reheat**

Outdoor Coil Entering Air Temp	Circuit 1		Circuit 2	
	Dis-charge ±10 psig	Suction ±5 psig	Dis-charge ±10 psig	Suction ±5 psig
65° F	267	122	270	113
75° F	308	128	313	120
85° F	355	133	363	127
95° F	399	136	407	130
105° F	448	139	456	132
115° F	503	142	510	136

**TABLE 11 581034-01
LGM/LCM150U Reheat**

Outdoor Coil Entering Air Temp	CIRCUIT 1		CIRCUIT 2	
	Dis-charge ±10 psig	Suction ±5 psig	Dis-charge ±10 psig	Suction ±5 psig
65° F	313	123	259	113
75° F	353	129	302	121
85° F	401	134	351	127
95° F	445	137	396	130
105° F	493	140	445	133
115° F	548	143	499	137

Charge Verification - Subcooling Method - AHRI Testing

1- Attach gauge manifolds to discharge and suction lines. With the economizer disabled, operate the unit in **cooling mode at high speed** using the following mobile service app menu path:

RTU MENU > SERVICE > COMPONENT TEST > COOLING > COOL 4

- 2- Use the liquid line pressure and a PT chart to determine the saturated liquid temperature.
- 3- Measure the liquid line temperature at the condenser outlet.

$$\text{Subcooling Temperature} = \text{Liquid Saturated Temperature} - \text{Liquid Temperature.}$$

4- Refer to table 12 for subcooling temperatures. A subcooling temperature greater than this value indicates an overcharge. A subcooling temperature less than this value indicates an undercharge.

**TABLE 12
SUBCOOLING TEMPERATURE**

Unit	Liquid Temp. Minus Ambient Temp.	
	1st Stage	2nd Stage
092	12°F ± 1 (6.7°C ± 0.5)	15°F ± 1 (8.3°C ± 0.5)
092 Reheat	17°F ± 1 (9.4°C ± 0.5)	15°F ± 1 (8.3°C ± 0.5)
102	11°F ± 1 (6.1°C ± 0.5)	14°F ± 1 (7.7°C ± 0.5)
102 Reheat	19°F ± 1 (6.7°C ± 0.5)	14°F ± 1 (7.7°C ± 0.5)
120	9°F ± 1 (5.0°C ± 0.5)	13°F ± 1 (7.2°C ± 0.5)
120 Reheat	15°F ± 1 (8.3°C ± 0.5)	8°F ± 1 (4.4°C ± 0.5)
150	10°F ± 1 (5.6°C ± 0.5)	11°F ± 1 (6.1°C ± 0.5)
150 Reheat	22°F ± 1 (12°C ± 0.5)	8°F ± 1 (4.4°C ± 0.5)

F-Compressor Controls

See unit wiring diagram to determine which controls are used on each unit.

- 1- High Pressure Switch (S4)
The compressor circuit is protected by a high pressure switch which opens at 640 psig ± 10 psig (4413 kPa ± 70 kPa) and automatically resets at 475 psig ± 20 psig (3275kPa ± 138 kPa).

- 2- Low Pressure Switch (S87, S88)
The compressor circuit is protected by a loss of charge switch. Switch opens at 40 psig ± 5 psig (276 ± 34 kPa) and automatically resets at 90 psig ± 5 psig (621 kPa ± 34 kPa).
- 3- Crankcase Heater (HR1, HR2)
Compressors have belly band compressor oil heaters which must be on 24 hours before running compressors. Energize by setting thermostat so that there is no cooling demand, to prevent compressor from cycling, and apply power to unit.
- 4- Thermal Protector (S5)
The compressors are thermally protected with automatic temperature switches.
- 5- Prognostics and Diagnostics Sensors (RT42-RT49)
Eight thermistors are located on specific points in the refrigeration circuit. The thermistors provide constant temperature feedback to the Unit Controller to protect the compressor. Thermistors take the place of the freezestat and low ambient pressure switch.

Prognostic & Diagnostic Sensors

Units are equipped with eight factory-installed thermistors (RT42 - RT49) located on different points on the refrigerant circuit.

The thermistors provide the Unit Controller with constant temperature readings of four specific locations on the refrigeration circuit. These temperatures are used as feedback in certain modes of unit operation. In addition, the Unit Controller uses these temperatures to initiate alarms such as loss of condenser or evaporator airflow and loss of charge.

Each thermistor must be specifically placed for proper unit operation and to initiate valid alarms. See table 13 for proper locations.

**TABLE 13
THERMISTOR LOCATION**

RT42, 43, 46, 47	RT44 & RT45	RT48 & 49
Figure 23	Figure 24	Figure 25

**THERMISTOR LOCATION RT42, 43, 46, 47
(EVAPORATOR COIL VIEW FROM FRONT SIDE OF UNIT)**

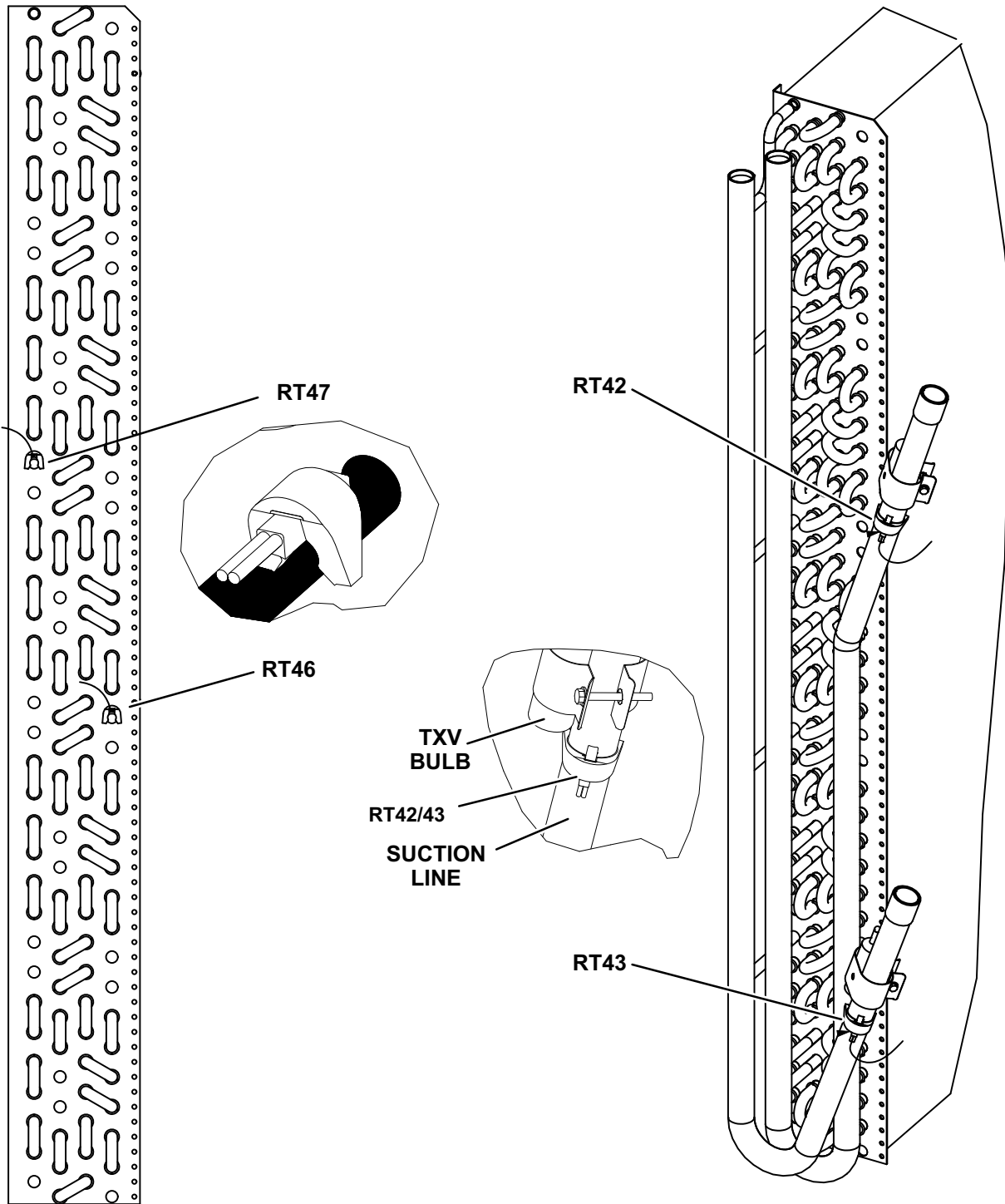

FIGURE 23

**THERMISTOR LOCATION RT44 & 45
(VIEW FROM FRONT SIDE OF UNIT)**

092, 102 CONDENSER COIL

120, 150 CONDENSER COIL

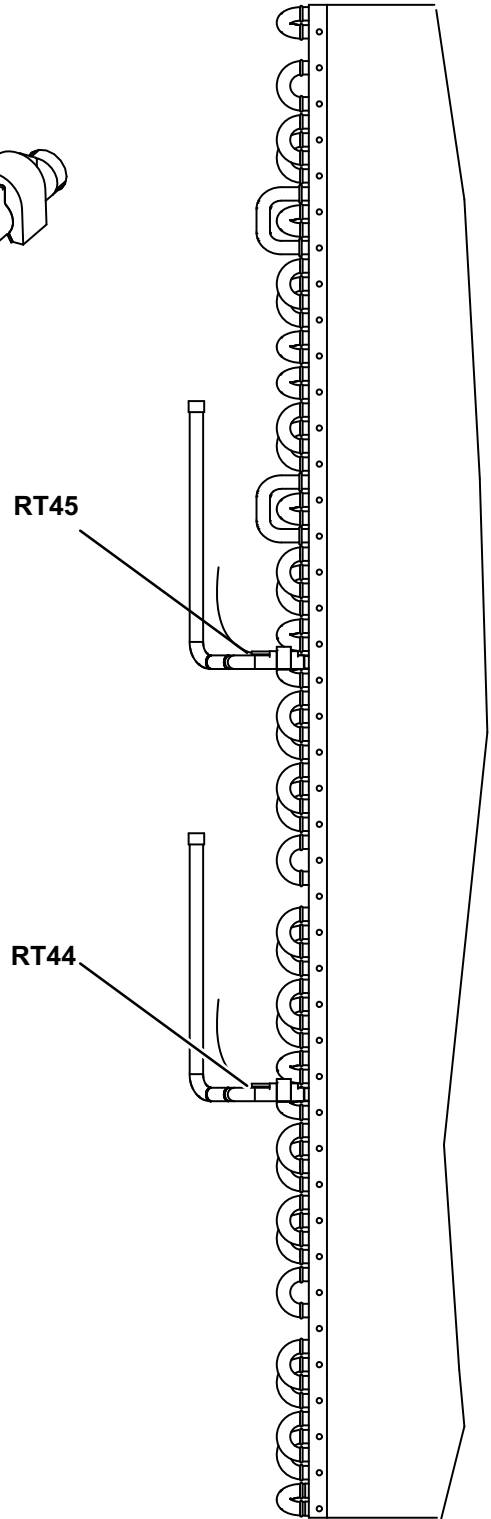
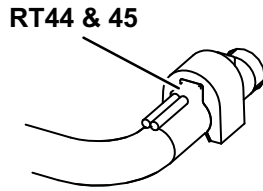
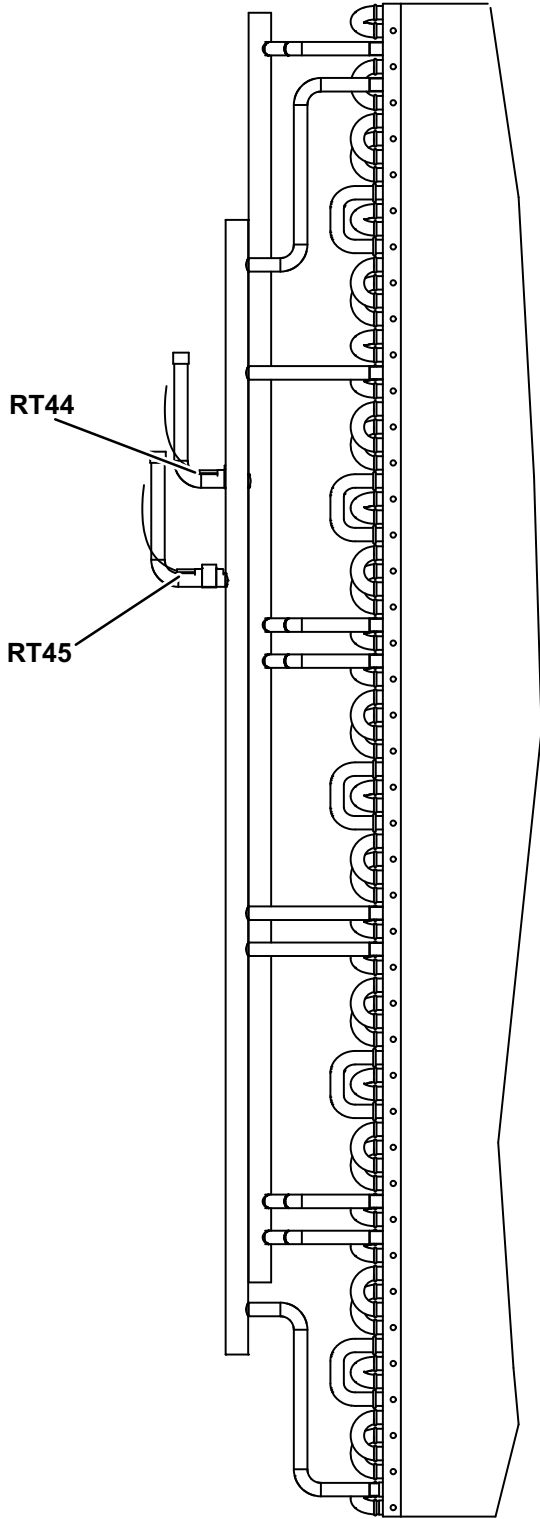

FIGURE 24

**THERMISTOR LOCATION RT48 & 49
(VIEW FROM FRONT SIDE OF UNIT)**

092, 102 CONDENSER COIL

120, 150 CONDENSER COIL

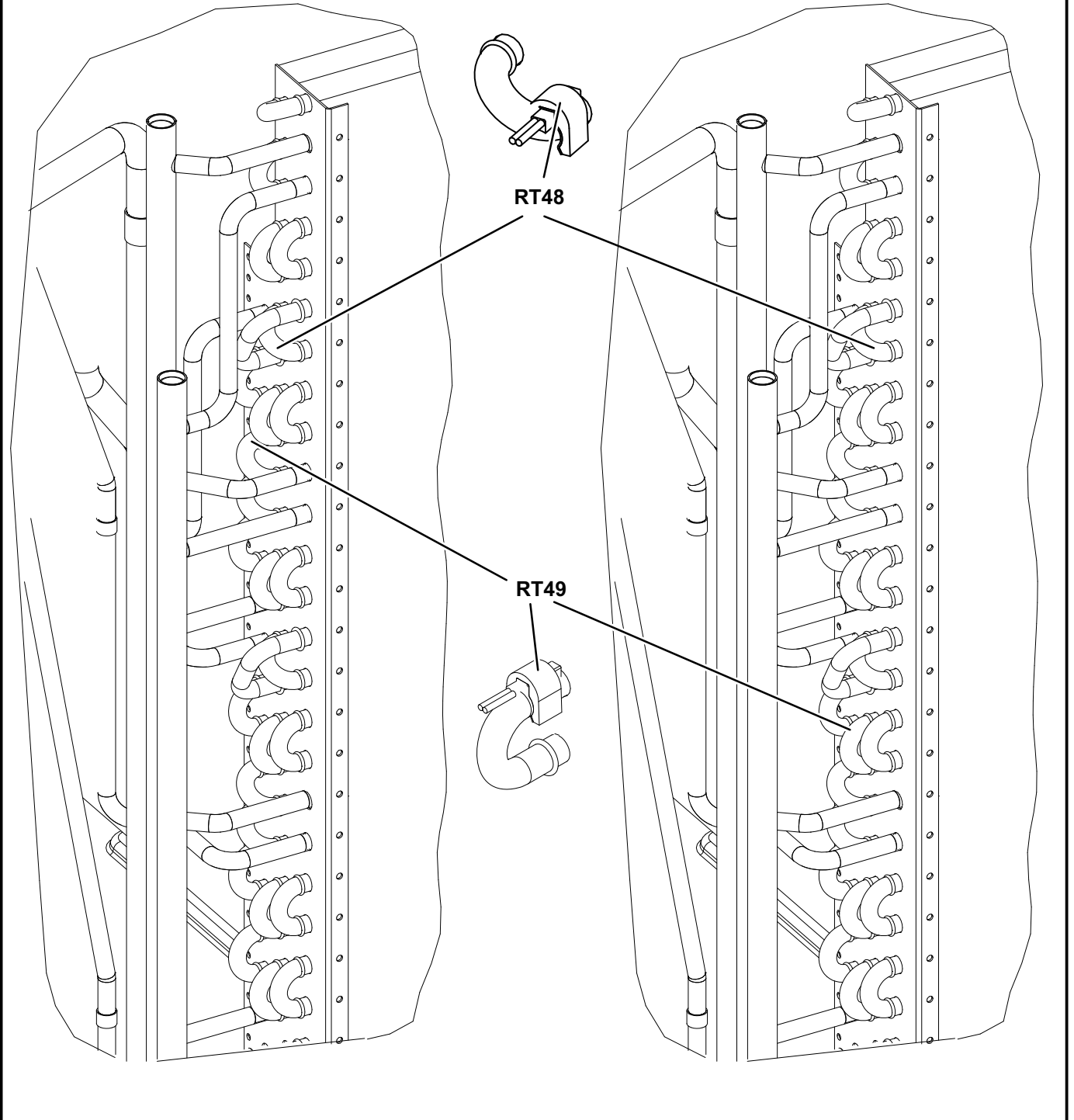

FIGURE 25

Gas Heat Start-Up (Gas Units)

FOR YOUR SAFETY READ BEFORE LIGHTING

⚠ WARNING



Electric shock hazard. Can cause injury or death. Do not use this unit if any part has been under water. Immediately call a qualified service technician to inspect the unit and to replace any part of the control system and any gas control which has been under water.

⚠ WARNING



Danger of explosion. Can cause injury or product or property damage. If overheating occurs or if gas supply fails to shut off, shut off the manual gas valve to the appliance before shutting off electrical supply.

⚠ WARNING



Electric shock hazard. Can cause injury or death. Before attempting to perform any service or maintenance, turn the electrical power to unit OFF at disconnect switch(es). Unit may have multiple power supplies.

⚠ WARNING

SMOKE POTENTIAL

The heat exchanger in this unit could be a source of smoke on initial firing. Take precautions with respect to building occupants and property. Vent initial supply air outside when possible.

BEFORE LIGHTING smell all around the appliance area for gas. Be sure to smell next to the floor because some gas is heavier than air and will settle on the floor.

Use only your hand to push in or turn the gas control knob. Never use tools. If the knob will not push in or turn by hand, do not try to repair it, call a qualified service technician. Force or attempted repair may result in a fire or explosion.

⚠ WARNING



Danger of explosion. Can cause injury or death. Do not attempt to light manually. Unit has a direct spark ignition system.

This unit is equipped with an automatic spark ignition system. There is no pilot. In case of a safety shutdown, move thermostat switch to **OFF** and return the thermostat switch to **HEAT** to reset ignition control.

A-Placing Unit In Operation

⚠ WARNING



Danger of explosion and fire. Can cause injury or product or property damage. You must follow these instructions exactly.

Gas Valve Operation for Honeywell VR8205Q/VR8305Q and White Rodgers 36H54 (figure 26 and 27).

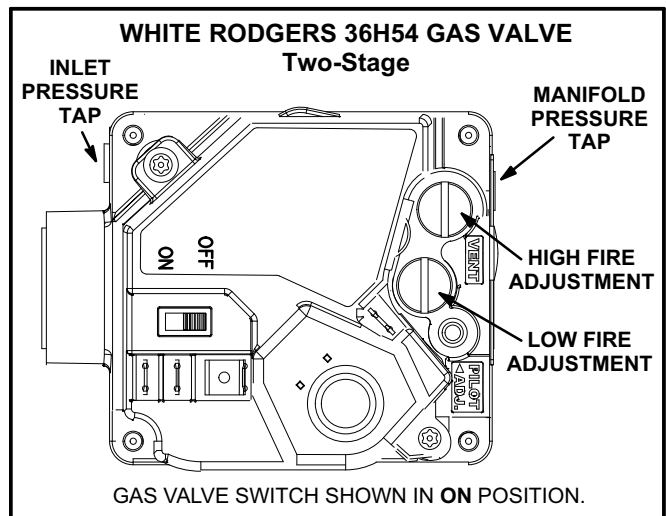

FIGURE 26

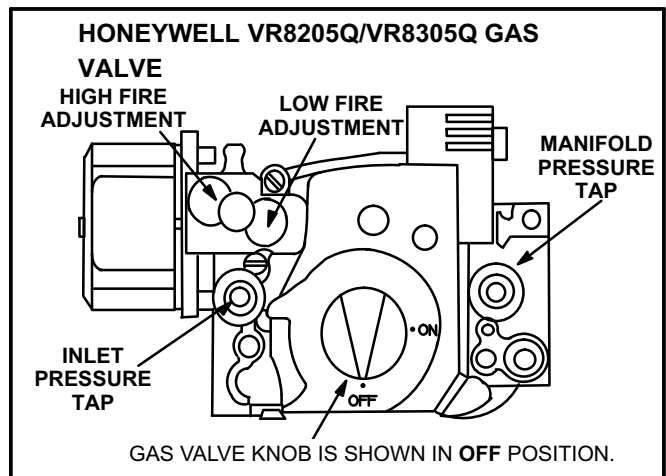





FIGURE 27

- 1- Set thermostat to lowest setting.
- 2- Turn off all electrical power to appliance.
- 3- This appliance is equipped with an ignition device which automatically lights the burner. Do **not** try to light the burner by hand.
- 4- Open or remove the heat section access panel.

- 5- Turn gas valve switch to **OFF**. See figure 26. On Honeywell VR8305Q gas valves, turn the knob on the gas valve clockwise  to “OFF”. Do not force. See figure 27.
- 6- Wait five (5) minutes to clear out any gas. If you then smell gas, **STOP!** Immediately call your gas supplier from a neighbor's phone. Follow the gas supplier's instructions. If you do not smell gas, go to the next step.
- 7- Turn gas valve switch to **ON**. See figure 26. On Honeywell VR8305Q gas valves, turn the knob on the gas valve counterclockwise  to “ON”. Do not force. See figure 27.
- 8- Close or replace the heat section access panel.
- 9- Turn on all electrical power to appliance.
- 10- Set thermostat to desired setting.
- 11- The ignition sequence will start.
- 12- If the appliance does not light the first time (gas line not fully purged), it will attempt up to two more ignitions before locking out.
- 13- If lockout occurs, repeat steps 1 through 10.
- 14- If the appliance will not operate, follow the instructions “Turning Off Gas to Appliance” and call your service technician or gas supplier.

Turning Off Gas to Unit

- 1- If using an electromechanical thermostat, set to the lowest setting.
- 2- Before performing any service, turn off all electrical power to the appliance.
- 3- Open or remove the heat section access panel.
- 4- Turn gas valve switch to **OFF**. On Honeywell VR8305Q gas valves, turn the knob on the gas valve clockwise  to “OFF”. Do not force.
- 5- Close or replace the heat section access panel.

WARNING



Danger of explosion. Can cause injury or death. Do not attempt to light manually. Unit has a direct spark ignition system.

Heating Operation and Adjustments

(Gas Units)

A-Heating Sequence of Operation

- 1- On a heating demand the combustion air inducer starts immediately.
- 2- Combustion air pressure switch proves inducer operation. After a 30-second pre-purge, power is allowed to ignition control. Switch is factory set and requires no adjustment.

- 3- Spark ignitor energizes and gas valve solenoid opens.
- 4- Spark ignites gas, ignition sensor proves the flame and combustion continues.
- 5- If flame is not detected after first ignition trial, ignition control will repeat steps 3 and 4 two more times before locking out the gas valve.
- 6- For troubleshooting purposes, an ignition attempt after lock out may be re-established manually. Move thermostat to “OFF” and return thermostat switch to “HEAT” position.

B-Limit Controls

Limit controls are factory-set and are not adjustable. The primary limit is located on the blower deck to the right of the blower housing.

C-Heating Adjustment

Main burners are factory-set and do not require adjustment.

The following manifold pressures are listed on the gas valve.

Natural Gas Units - Low Fire - 1.6” w.c. (not adjustable)

Natural Gas Units - High Fire - 3.7” w.c.

LP Gas Units - Low Fire - 5.5” w.c. (not adjustable)

LP Gas Units - High Fire - 10.5” w.c.

Electric Heat Start-Up (Cooling Units)

Factory- or Field-Installed Option

Electric heat will stage on and cycle with thermostat demand. Number of stages of electric heat will vary depending on electric heat assembly. See electric heat wiring diagram on unit for sequence of operation.

SCR Electric Heat Controller (LCM Units)

Optional factory-installed SCR (A38) will provide small amounts of power to the electric heat elements to efficiently maintain warm duct air temperatures when there is no heating demand. The SCR maintains duct air temperature based on input from a field-provided and installed thermostat (A104) and duct sensor (RT20). SCR is located in the electric heat compartment in front of the elements. Use only with a thermostat.

Use the instructions provided with the thermostat to set DIP switches as follows: S1 On, S2 Off, S3 Off. Use the instructions provided with the duct sensor to install sensor away from electric element radiant heat and in a location where discharge air is a mixed average temperature.

Once power is supplied to unit, zero SCR as follows:

- 1- Adjust thermostat (A104) to minimum position.
- 2- Use a small screwdriver to slowly turn the ZERO potentiometer on the SCR until the LED turns solid red.
- 3- Very slowly adjust the potentiometer the opposite direction until the LED turns off.

Cooling Operation

This is a summary of cooling operation. Refer to the sequence of operation provided in the Engineering Handbook or Service Manual for more detail.

Note - Free cooling is locked-out during reheat operation. Refer to hot gas reheat start-up and operation section for details.

A-Two-Stage Thermostat

1-Economizer With Outdoor Air Suitable

Y1 Demand -

- Compressors Off
- Blower Cooling Low
- Dampers modulate

Note - If dampers are at maximum open for five minutes, compressors are energized and blower stays on cooling high.

Y2 Demand -

- Compressors Modulate
- Blower Cooling High
- Dampers Maximum Open

2-No Economizer or Outdoor Air Not Suitable

Y1 Demand -

- Compressors Modulate
- Blower Cooling Low
- Dampers Minimum Position

Y2 Demand -

- Compressors Modulate
- Blower Cooling High
- Dampers Minimum Position

B-Three-Stage Thermostat

1-Economizer With Outdoor Air Suitable

Y1 Demand -

- Compressors Off
- Blower Cooling Low
- Dampers Modulate

Note - If dampers are at maximum open for five minutes, compressors are energized and blower stays on cooling high.

Y2 Demand -

- Compressors Modulate
- Blower Cooling Intermediate
- Dampers Maximum Open

Y3 Demand -

- Compressors Modulate
- Blower Cooling High
- Dampers Maximum Open

C-Room Sensor

1-Economizer With Outdoor Air Suitable

- Compressors Off
- Blower Modulates
- Dampers modulate

Note - If dampers are at maximum open for five minutes, compressors are energized and the blower modulates.

2-No Economizer or Outdoor Air Not Suitable

- Compressors Modulate
- Blower Modulates
- Dampers Minimum Position

Modulating Hot Gas Reheat Start-Up And Operation

General

Hot gas reheat units provide a dehumidifying mode of operation. These units contain a reheat coil adjacent to and downstream of the evaporator coil. Reheat coil solenoid valve, L14, routes hot discharge gas from the compressor to the reheat coil. Return air pulled across the evaporator coil is cooled and dehumidified; the reheat coil adds heat to supply air. See figure 28 for reheat refrigerant routing and figure 29 for standard refrigerant routing.

L14 Reheat Coil Solenoid Valve

When Unit Controller input (Unit Controller J298-5 or J299-8) indicates room conditions require dehumidification, L14 reheat valve is energized (Unit Controller J394-1) and refrigerant is routed to the reheat coil.

Reheat Setpoint

Reheat is factory-set to energize when indoor relative humidity rises above 60% (default).

The reheat setpoint can be adjusted by changing mobile service app Settings - Control menu. A setting of 100% will operate reheat from an energy management system digital output.

The reheat setpoint can also be adjusted using an optional Network Control Panel (NCP). Reheat will terminate when the indoor relative humidity falls 3% (57% default) or the digital output de-energizes. The reheat deadband can be adjusted at Settings - Control menu.

Check-Out

Test hot gas reheat operation using the following procedure.

- 1- Make sure reheat is wired as shown in wiring section.
- 2- Make sure unit is in local thermostat mode.
- 3- Select:

RTU MENU > SERVICE > COMPONENT TEST >
DEHUMIDIFICATION

The blower and compressor 1 (reheat) should be operating. DEHUMIDIFIER 1 ON will appear.

- 4- Press STOP to discontinue the testing mode.

Compressor 1 (reheat) and blower should de-energize.

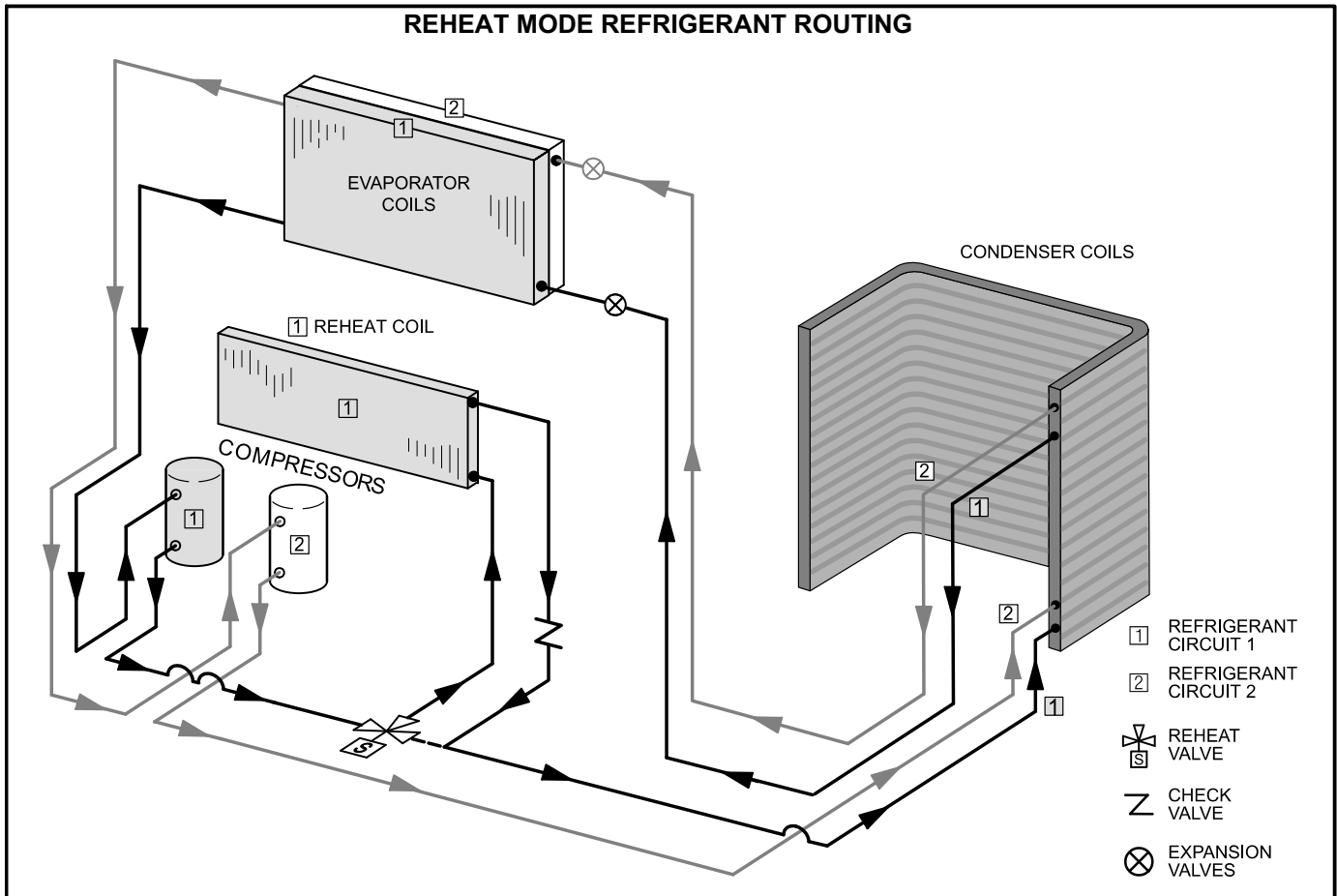

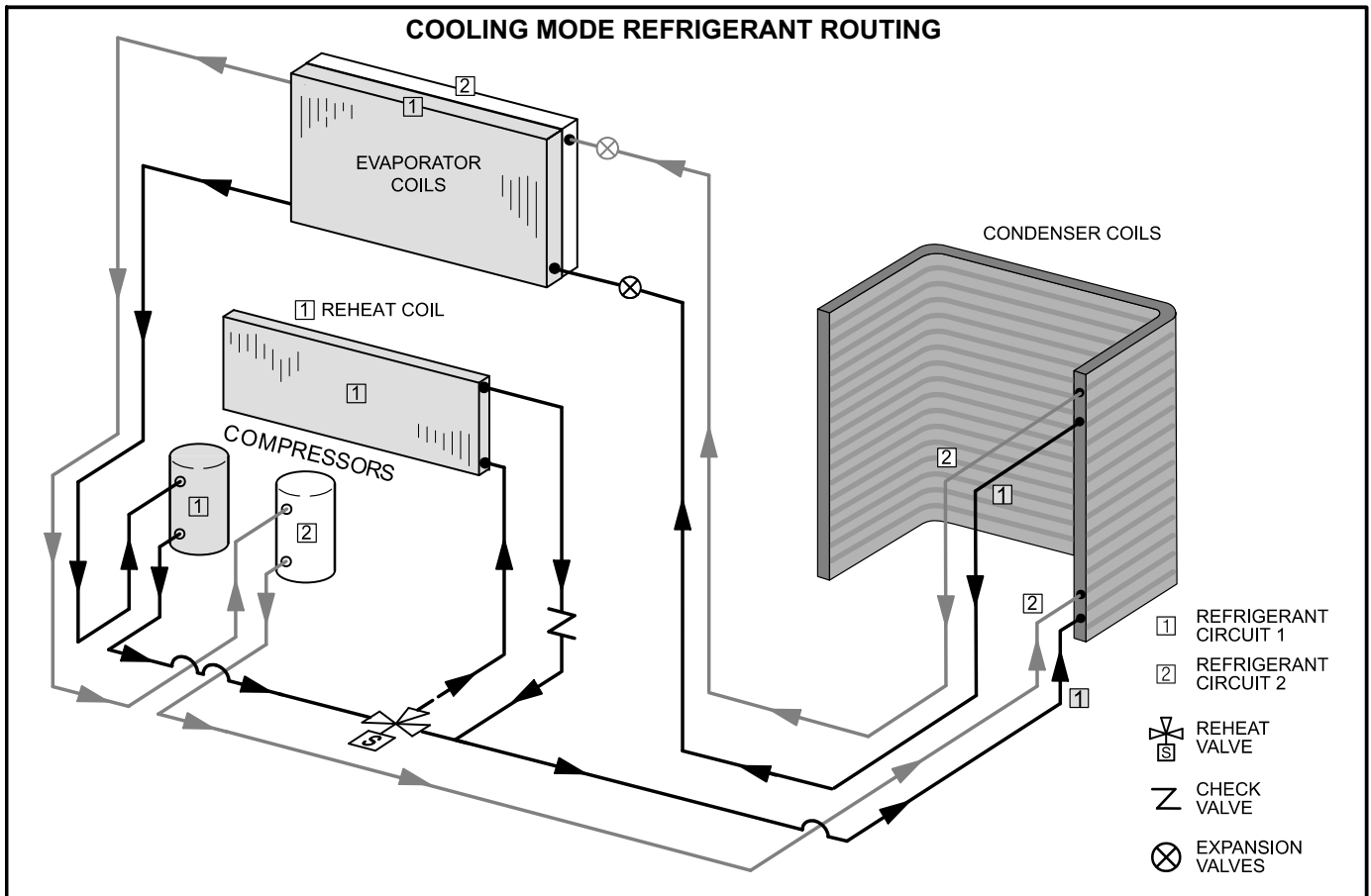

FIGURE 29

Default Reheat Operation

TABLE 14
Reheat Operation - Two Cooling Stages - Default

T'stat and Humidity Demands	Operation
Reheat Only	Compressor 1 Reheat
Reheat & Y1	Compressor 1 & 2 Enhanced Dehumidification at Low CFM
Reheat & Y1 & Y2	Compressor 1 & 2 Enhanced Dehumidification at High CFM

*If there is no reheat demand and outdoor air is suitable, free cooling will operate.

**If there is no reheat demand and outdoor air is suitable, free cooling and compressor 1 will operate.

Service

The unit should be inspected once a year by a qualified service technician.

⚠ CAUTION

Label all wires prior to disconnection when servicing controls. Wiring errors can cause improper and dangerous operation. Verify proper operation after servicing.

A-Filters

Units are equipped with four 20 X 25 X 2" filters. Filters should be checked monthly and replaced when necessary with filters of like kind and size. Take note of air flow direction marking on filter frame when reinstalling filters. See figure 30.

NOTE-Filters must be U.L.C. certified or equivalent for use in Canada.

B-Lubrication

All motors are lubricated at the factory. No further lubrication is required.

C-Burners (Gas Units)

Periodically examine burner flames for proper appearance during the heating season. Before each heating season examine the burners for any deposits or blockage which may have occurred.

Clean burners as follows:

- 1- Turn off both electrical power and gas supply to unit.
- 2- Remove burner compartment access panel.

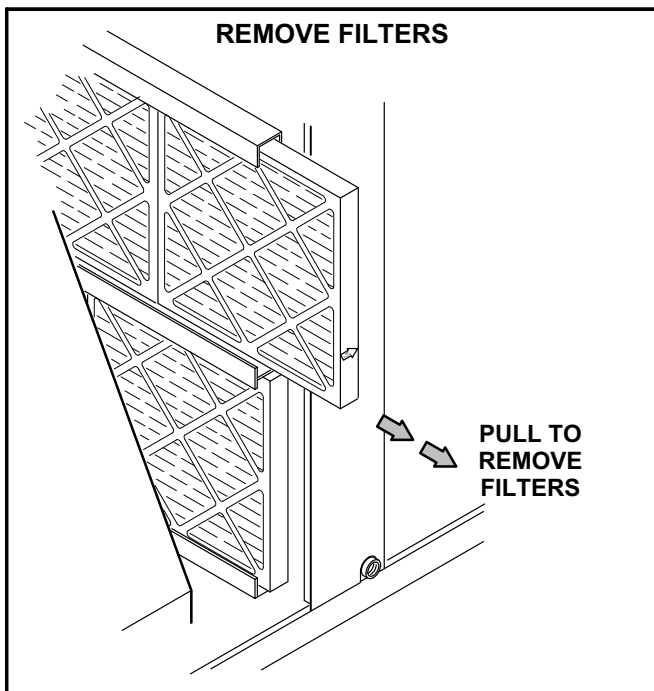

FIGURE 30

- 3- Remove screws securing burner assembly to burner support and remove assembly. See figure 31. Clean as necessary.
- 4- Locate the ignitor under the left burners. Check ignitor spark gap with appropriately sized twist drills or feeler gauges. See figure 32.
- 5- Check the alignment of the ignitor and the sensor as shown in figure 33 and table 15.
- 6- Replace burners and screws securing burner.
- 7- Replace access panel.
- 8- Restore electrical power and gas supply. Follow lighting instructions attached to unit and use inspection port in access panel to check flame.

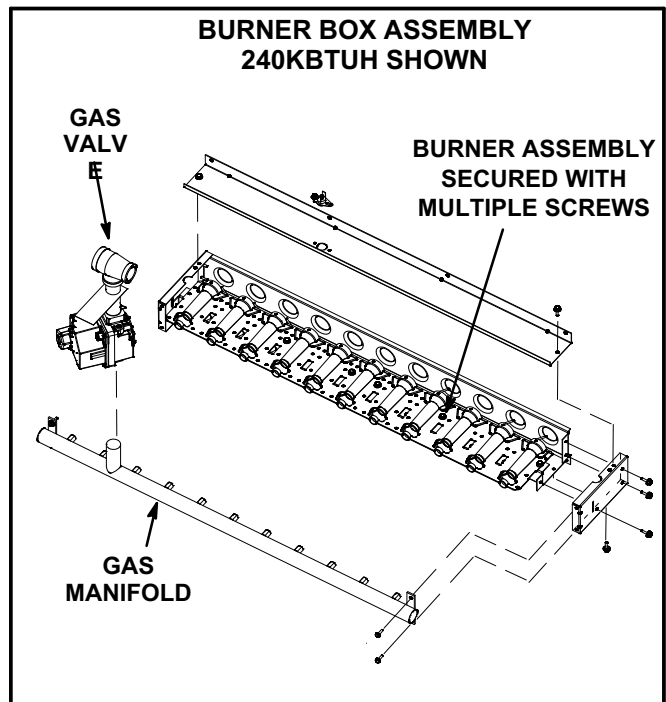

FIGURE 31

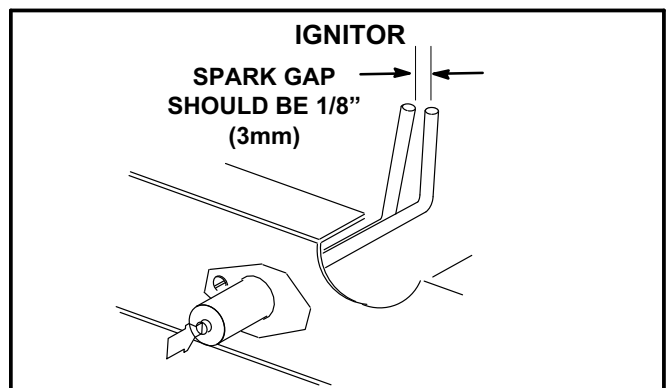

FIGURE 32

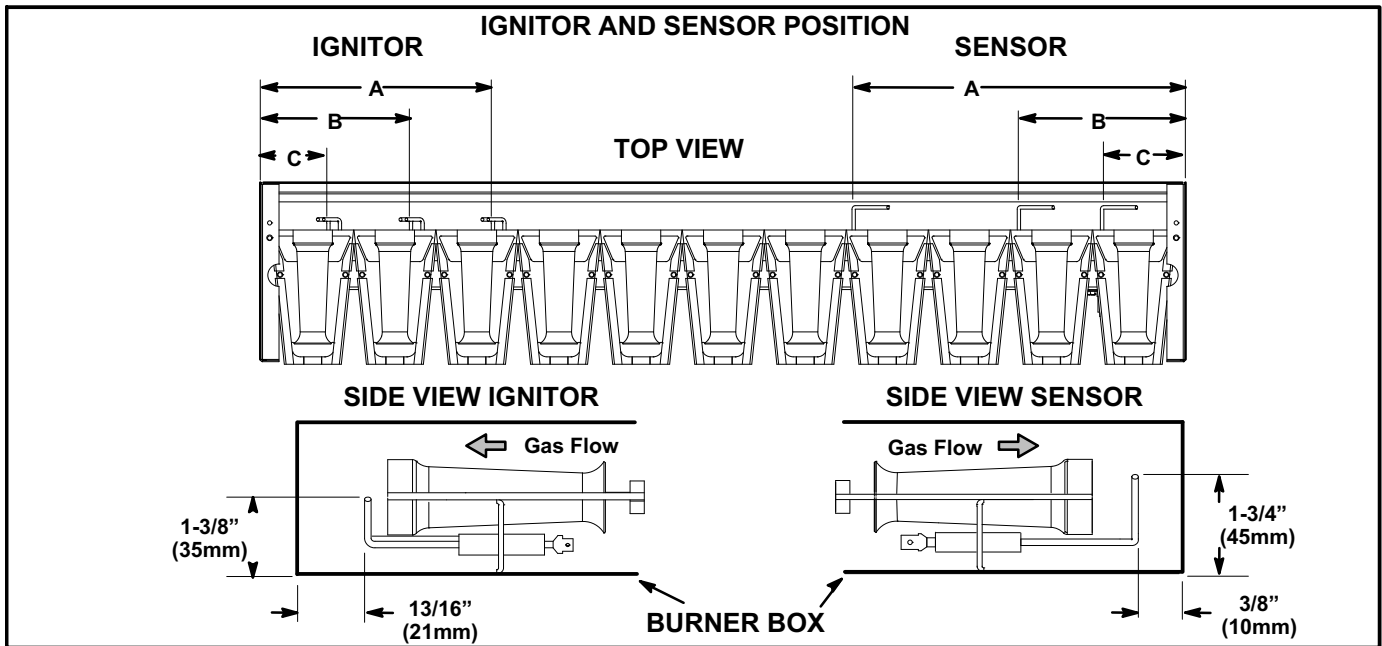

FIGURE 33

TABLE 15

Dimension	Unit Btuh Input	Length - in. (mm)	
		Ignitor	Sensor
A	130K	7-3/4 (197)	11 (279)
B	180K	5 (127)	5-1/2 (140)
C	240K	2-1/4 (57)	2-3/4 (70)

D-Combustion Air Inducer (Gas Units)

A combustion air proving switch checks combustion air inducer operation before allowing power to the gas controller. Gas controller will not operate if inducer is obstructed.

⚠ WARNING

Danger of explosion. Can cause injury or death. Do not overtighten main burner mounting screws. Snug tighten only.

Under normal operating conditions, the combustion air inducer wheel should be checked and cleaned prior to the heating season. However, it should be examined periodically during the heating season to establish an ideal cleaning schedule. With power supply disconnected, the condition of the inducer wheel can be determined by looking through the vent opening.

Clean combustion air inducer as follows:

- 1- Shut off power supply and gas to unit.
- 2- Disconnect pressure switch air tubing from combustion air inducer port.

- 3- Remove and retain screws securing combustion air inducer to flue box. Remove vent connector. See figure 34.
- 4- Clean inducer wheel blades with a small brush and wipe off any dust from housing. Clean accumulated dust from front of flue box cover.
- 5- Return combustion air inducer motor and vent connector to original location and secure with retained screws. It is recommended that the combustion air inducer gasket be replaced during reassembly.
- 6- Clean combustion air inlet louvers on heat access panel using a small brush.

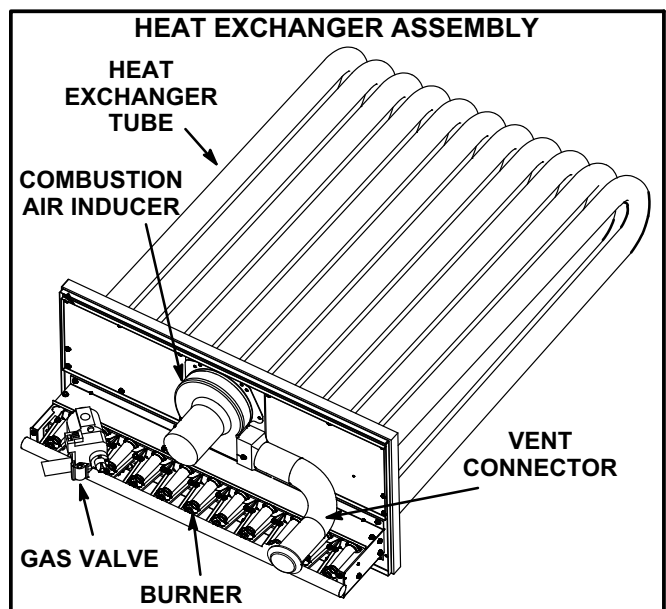

FIGURE 34

E-Flue Passageway and Flue Box (Gas Units)

- 1- Remove combustion air inducer assembly as described in section D.
- 2- Remove flue box cover. Clean with a wire brush as required.
- 3- Remove inserts if installed. See figure 36.
- 4- Clean tubes with a wire brush.
- 5- Reassemble the unit. The flue box cover gasket and combustion air inducer gasket should also be replaced during reassembly.

F-Gas Heat Exchanger Inserts

- 1- Inserts are installed on standard (130,000Btuh) and high (240,000Btuh) heat exchangers. Medium heat exchangers do not require inserts. See figure 36.

G-Evaporator Coil

Inspect and clean coil at beginning of each cooling season. Clean using mild detergent or commercial coil cleaner. Flush coil and condensate drain with water taking care not to get insulation, filters and return air ducts wet.

H-Supply Air Blower Wheel

Annually inspect supply air blower wheel for accumulated dirt or dust. Turn off power before attempting to remove access panel or to clean blower wheel.

J-Condenser Coil

Clean condenser coil annually with detergent or commercial coil cleaner and inspect monthly during the cooling season. Access panels are provided on front and back of condenser section.

K-Needlepoint Bipolar Ionizer

The ionizer was designed for low maintenance. The device should be checked semi-annually to confirm the brushes are clean for maximum output. The ionizer is located on the blower deck. See figure 35.

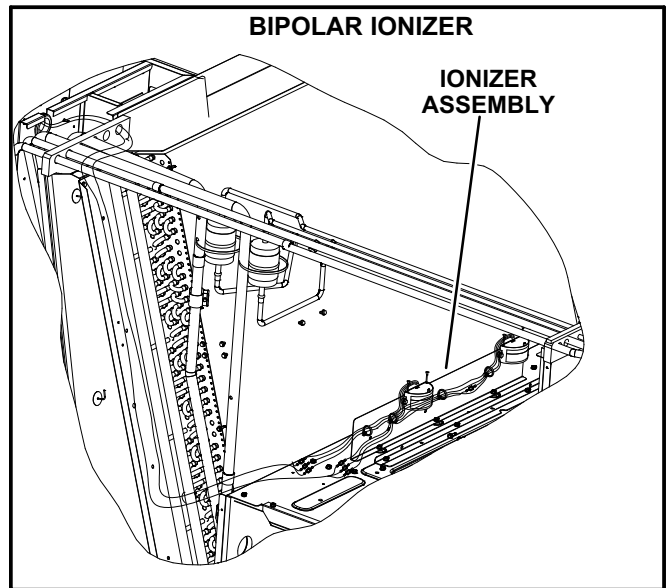

FIGURE 35

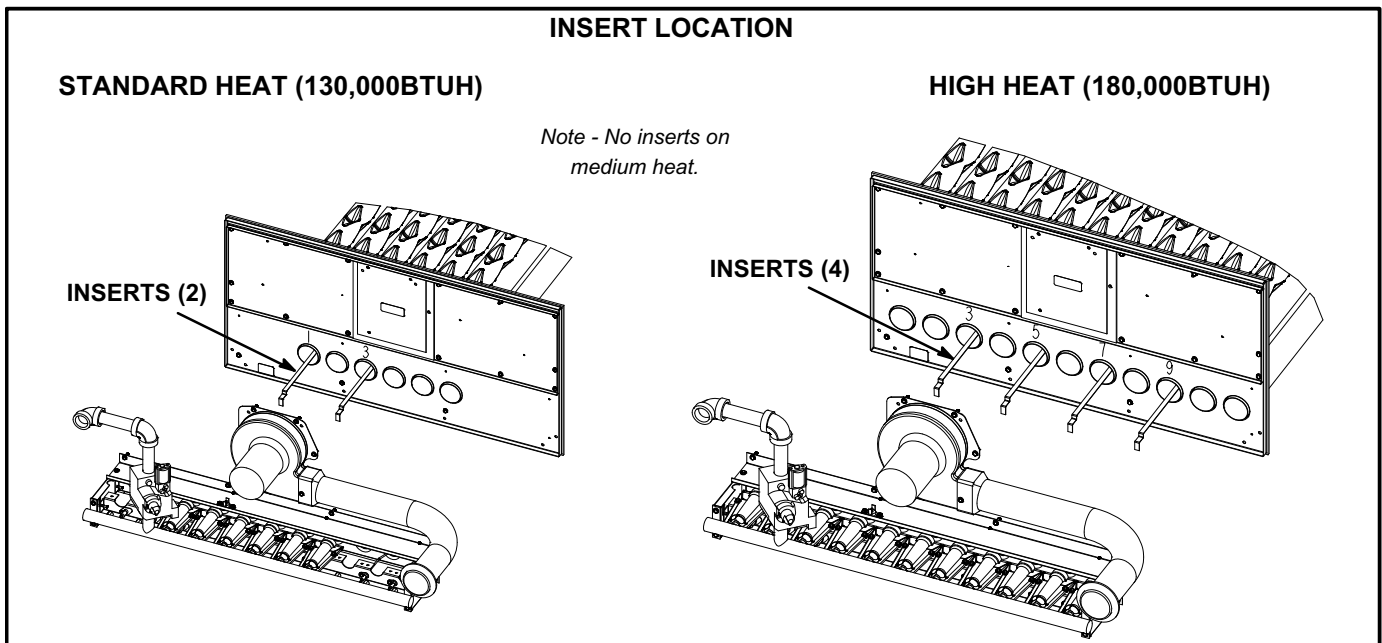

FIGURE 36

L-UVC Light

Factory-Installed UVC Light

When the UVC light is factory installed, the lamp is shipped in a foam sleeve. The lamp is attached to the UVC light assembly on the blower deck. See figure 38. Remove the lamp and install into the UVC light assembly as shown in steps 2 through 11.

Annual Lamp Replacement

⚠ WARNING

Personal Burn Hazard.

Personal injury may result from hot lamps. During replacement, allow lamp to cool for 10 minutes before removing lamp from fixture.

The lamp should be replaced every 12 months, as UVC energy production diminishes over time.

- 1- Obtain the correct replacement lamp for your germicidal light model.
- 2- Disconnect power to the rooftop unit before servicing the UVC kit.
- 3- Open the blower access door.
- 4- Remove the screw in wire tie from the UVC assembly and disconnect the 4-pin connector from the lamp end.
- 5- Remove and retain the (3) screws securing the UVC assembly. Carefully slide the complete UVC assembly out through the blower access door. See figure 38.
- 6- Allow 10 minutes before touching the lamps. Then, carefully remove the old lamp from the lamp holder clips.
- 7- Wear cotton gloves or use a cotton cloth when handling the new lamp. Place the new lamp in the holder clips of the UVC assembly. Verify that the lamp flange at the connector end is sandwiched between the lamp holder clip and the sheet-metal end stop (see figure 37).
- 8- Carefully place the UVC assembly on the blower deck. Line up the mounting holes on the UVC assembly with the mounting holes on the blower deck. See figure 38. Use the retained screws provided to attach the UVC assembly in place.
- 9- Close the blower access door.
- 10- Reconnect power to the rooftop unit.
- 11- Open the filter access door and look through the view port in the triangular sheet-metal panel to verify that the UVC light is on.

If UVC lamp does not come on:

- 1- Check Power Wiring: Disconnect 1/4" QC (quick connects) of the UVC cable near the UVC assembly. With Power ON, use multimeter to test 110-230V at the 1/4"QC quick connects from the control panel.

- 2- Check Lamp: Carefully remove the UVC assembly out of the rooftop unit. Use multimeter to test for continuity across each pair of pins at each end of the lamp.

- 3- Check Lamp Installation: Make sure that lamp's pins snap properly into the lamp holder.

LED(s) not illuminated

Power status LED not lit—Check that the lamp unit is connected to the proper power source and is wired correctly.

Lamp status LED(s) not lit—

- 1- Check that lamp 4-pin connectors are properly engaged.
- 2- Ohm-check across the lamp pins to check for continuity of lamp filaments (see figure 40).

Troubleshooting charts are provided to aid in determining the cause of any problems encountered (figures 39 and 40).

Lamp Disposal

Hg-LAMP Contains Mercury.—Manage in accordance with local, state and federal disposal laws. Refer to www.lamprecycle.org or call 800-953-6669.

Proper Clean-up Technique in Case of Lamp Breakage

Wear protective gloves, eye wear and mask.

Sweep the broken glass and debris into a plastic bag, seal the bag, and dispose of properly. Contact your local waste management office for proper disposal.

Do not use a vacuum cleaner. Do not incinerate.

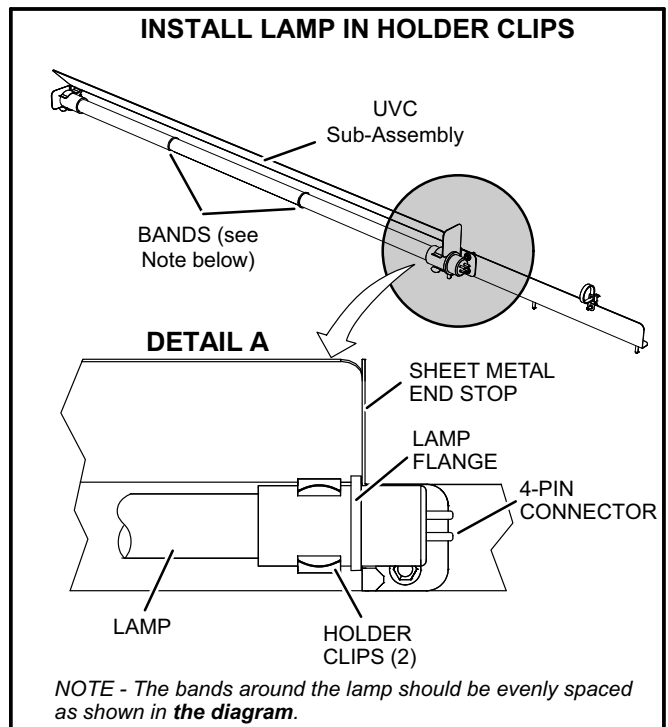

FIGURE 37

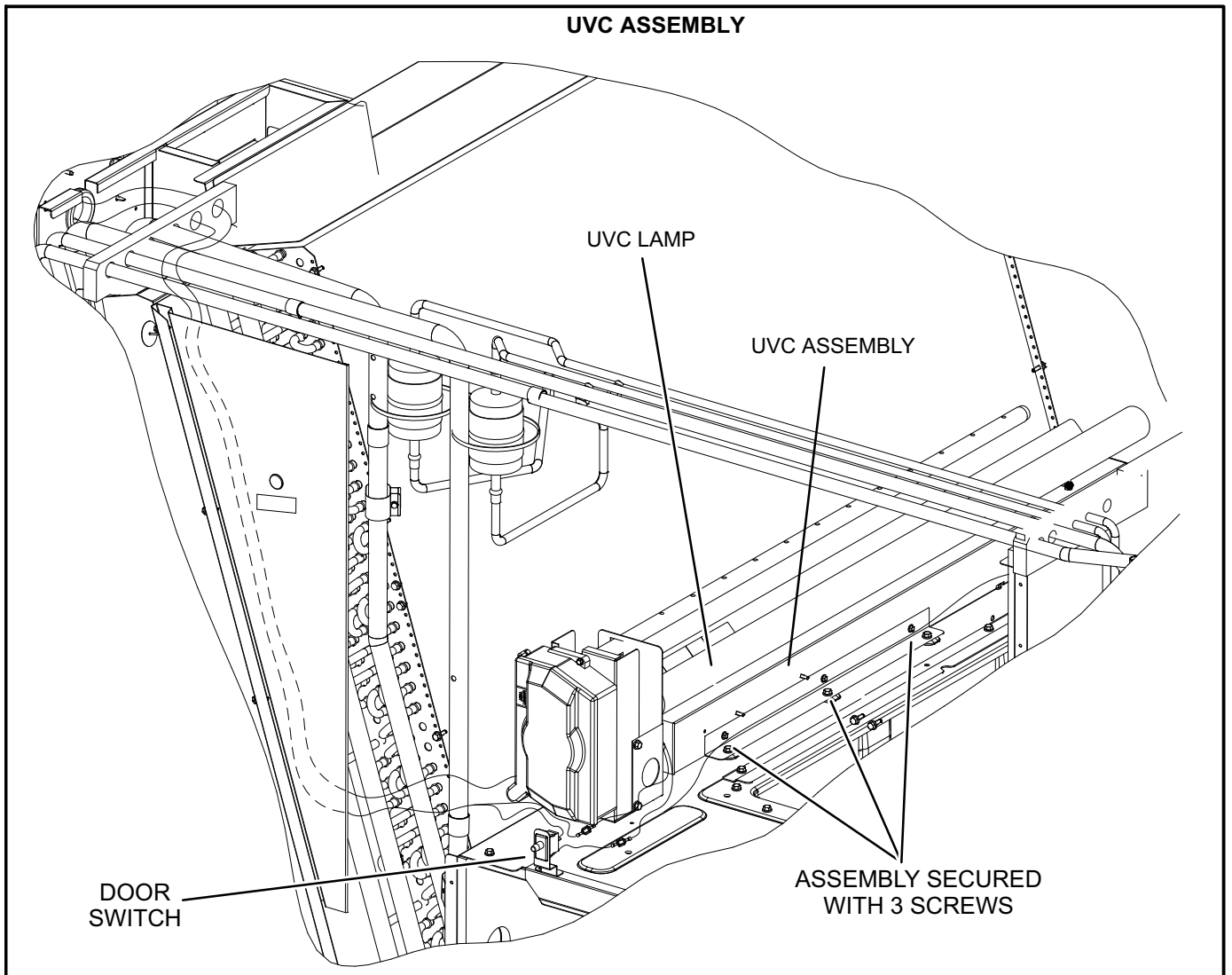

FIGURE 38

⚠ DANGER

Ultraviolet (UVC) Radiation hazard.

Any exposure will cause significant eye damage and may cause skin damage.

DO NOT look into UVC light source.

Access panels must be in place during appliance operation.

UVC LIGHT TROUBLESHOOTING - POWER

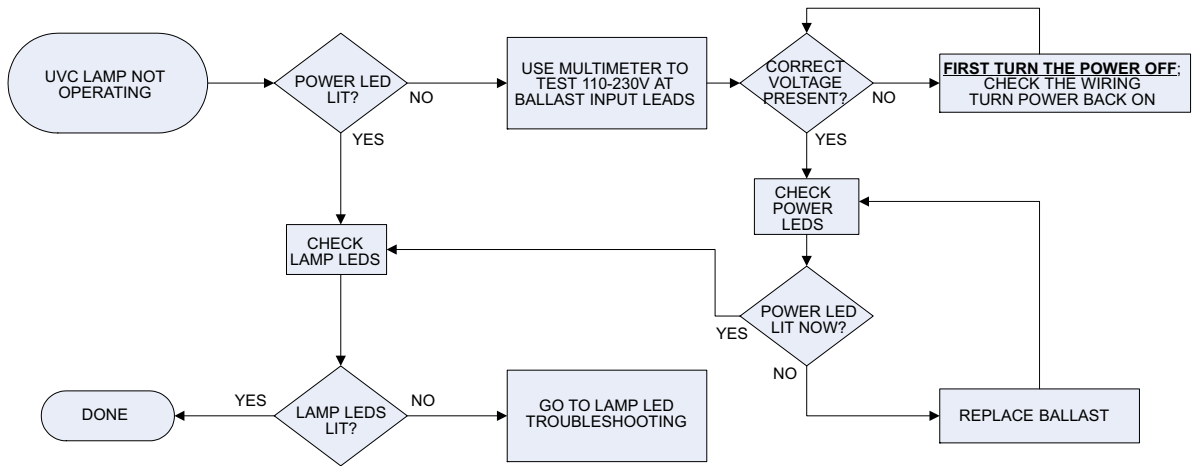

FIGURE 39

UVC LIGHT TROUBLESHOOTING - LAMP

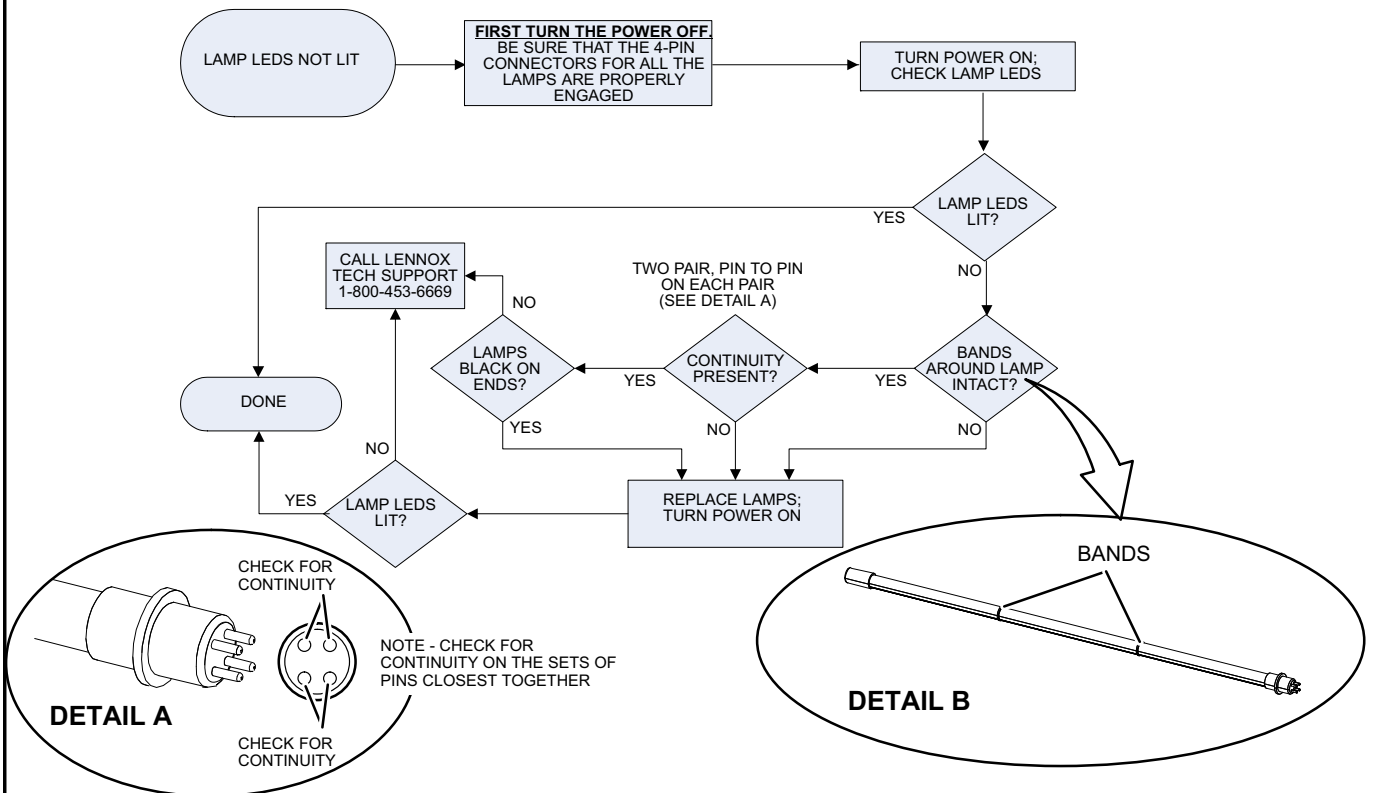

FIGURE 40

Field-Installed Accessories

When field-installing the following accessories, refer to the latest online installation instruction.

TABLE 16

Accessory	Instruction #
Economizer	507227-XX
Outdoor Air Damper	506340-XX
Electric Heat	507250-XX
Smoke Detector	506437-XX

Factory Unit Controller Settings

Use the Unit Controller to adjust parameters; menu paths are shown in each table. Refer to the Unit Controller manual provided with each unit.

Tables 17 through 23 show factory settings (in degrees, % of fan CFM, etc.). Record adjusted settings on the label located inside the compressor access panel.

When field installing optional kits and accessories, the Unit Controller must be configured to identify the option before it will function. Refer to figures 41 and 42 to determine whether the Unit Controller configuration I.D. must change. To configure the option, use RTU MENU > SETUP > INSTALL menu path. Press NEXT until CONFIGURATION ID 1 or 2 appears depending on the option installed. Change the appropriate character in the configuration I.D. For example, when an economizer is installed using a single enthalpy sensor, change configuration I.D. 1, the second character, to "S".

TABLE 17
581038-01

Units With BACnet Settings	
RTU Menu > Network Integration > Network Setup Wizard > BACnet MS/TP > See BACnet MAC Address	
BACNET MAC ADDRESS:	
Units With Room Sensor, CPC/LSE Gateway Settings	
RTU Menu > Network Integration > Network Setup Wizard > SBUS > Set SBUS Address	
LCONN ADDRESS:	

TABLE 18
580683

LGM/LCM 092U4E (2-Compressor) Staged Direct Drive			
Parameter	Factory Setting	Field Setting	Description
Note: Any changes to Smoke CFM setting must be adjusted before the other CFM settings. Use SETTINGS > RTU OPTIONS > EDIT PARAMETERS			
12	3000 CFM	CFM	Blower CFM during smoke detection.
SETUP > TEST & BALANCE (can also use SETTINGS > RTU OPTIONS > BLOWER > SPEEDS)			
	3000 CFM	CFM	Blower CFM during heating.
	2625 CFM	CFM	Blower CFM during high speed cooling (2 compressor) operation.
	800 CFM	CFM	Blower CFM during low speed cooling (1 compressor) operation.
	800 CFM	CFM	Blower CFM during ventilation.
	1195 RPM	RPM*	Adjust RPM based on unit static and blower tables to reach target CFM.
<i>*Once all four blower settings are entered, the target (highest of the heating and cooling settings) CFM will be displayed. Once the RPM is saved for the target CFM, all other blower RPM values are set by the Unit Controller according to the field CFM setting..</i>			
SETUP > TEST & BALANCE (can also use SETTINGS > RTU OPTIONS > DAMPER)			
	0%	%	Damper min. position during LOW blower operation.
	0%	%	Damper min. position during HIGH blower operation.
	50%	%	Min. Damper % for stage 1 power exhaust operation.
SETTINGS > RTU OPTIONS > EDIT PARAMETERS			
29	101%	%Open	Damper minimum position during G blower operation. (Setting parameter 29 to "101" disables parameter 29 and passes control to parameter 9 or 132)
216	10%	%	Deadband % for stage 1 power exhaust operation.
SETTINGS > RTU OPTIONS > EDIT PARAMETER			
85	0°F	°F	Compressor 1 low temp lockout. Settings lower than 0°F could void warranty.
86	0°F	°F	Compressor 2 low temp lockout. Settings lower than 0°F could void warranty.

TABLE 19
581053-01

LGM/LCM102U4E (2-Compressor) Staged Direct Drive			
Parameter	Factory Setting	Field Setting	Description
Note: Any changes to Smoke CFM setting must be adjusted before the other CFM settings. Use SETTINGS > RTU OPTIONS > EDIT PARAMETERS			
12	3400 CFM	CFM	Blower CFM during smoke detection.
SETUP > TEST & BALANCE (can also use SETTINGS > RTU OPTIONS > BLOWER > SPEEDS)			
	3400 CFM	CFM	Blower CFM during heating.
	2975 CFM	CFM	Blower CFM during high speed cooling (2 compressor) operation.
	800 CFM	CFM	Blower CFM during low speed cooling (1 compressor) operation.
	800 CFM	CFM	Blower CFM during ventilation.
	1285 RPM	RPM*	Adjust RPM based on unit static and blower tables to reach target CFM.
<i>*Once all four blower settings are entered, the target (highest of the heating and cooling settings) CFM will be displayed. Once the RPM is saved for the target CFM, all other blower RPM values are set by the Unit Controller according to the field CFM setting..</i>			
SETUP > TEST & BALANCE (can also use SETTINGS > RTU OPTIONS > DAMPER)			
	0%	%	Damper min. position during LOW blower operation.
	0%	%	Damper min. position during HIGH blower operation.
	50%	%	Min. Damper % for stage 1 power exhaust operation.
SETTINGS > RTU OPTIONS > EDIT PARAMETERS			
29	101%	%Open	Damper minimum position during G blower operation. (Setting parameter 29 to "101" disables parameter 29 and passes control to parameter 9 or 132)
216	10%	%	Deadband % for stage 1 power exhaust operation.
SETTINGS > RTU OPTIONS > EDIT PARAMETER			
85	0°F	°F	Compressor 1 low temp lockout. Settings lower than 0°F could void warranty.
86	0°F	°F	Compressor 2 low temp lockout. Settings lower than 0°F could void warranty.

TABLE 20
580684

LGM/LCM 120U4E (2-Compressor) Staged Direct Drive			
Parameter	Factory Setting	Field Setting	Description
Note: Any changes to Smoke CFM setting must be adjusted before the other CFM settings. Use SETTINGS > RTU OPTIONS > EDIT PARAMETERS			
12	4000 CFM	CFM	Blower CFM during smoke detection.
SETUP > TEST & BALANCE (can also use SETTINGS > RTU OPTIONS > BLOWER > SPEEDS)			
	4000 CFM	CFM	Blower CFM during heating.
	3500 CFM	CFM	Blower CFM during high speed cooling (2 compressor) operation.
	875 CFM	CFM	Blower CFM during low speed cooling (1 compressor) operation.
	875 CFM	CFM	Blower CFM during ventilation.
	1425 RPM	RPM*	Adjust RPM based on unit static and blower tables to reach target CFM.
<i>*Once all four blower settings are entered, the target (highest of the heating and cooling settings) CFM will be displayed. Once the RPM is saved for the target CFM, all other blower RPM values are set by the Unit Controller according to the field CFM setting..</i>			
SETUP > TEST & BALANCE (can also use SETTINGS > RTU OPTIONS > DAMPER)			
	0%	%	Damper min. position during LOW blower operation.
	0%	%	Damper min. position during HIGH blower operation.
	50%	%	Min. damper % for stage 1 power exhaust operation.
SETTINGS > RTU OPTIONS > EDIT PARAMETERS			
29	101%	%Open	Damper minimum position during G blower operation. (Setting parameter 29 to "101" disables parameter 29 and passes control to parameter 9 or 132)
216	10%	%	Deadband % for stage 1 power exhaust operation.
SETTINGS > RTU OPTIONS > EDIT PARAMETER			
85	0°F	°F	Compressor 1 low temp lockout. Settings lower than 0°F could void warranty.
86	0°F	°F	Compressor 2 low temp lockout. Settings lower than 0°F could void warranty.

TABLE 21
580685

LGM/LCM 150U4E (2-Compressor) Staged Direct Drive			
Parameter	Factory Setting	Field Setting	Description
Note: Any changes to Smoke CFM setting must be adjusted before the other CFM settings. Use SETTINGS > RTU OPTIONS > EDIT PARAMETERS			
12	5000 CFM	CFM	Blower CFM during smoke detection.
SETUP > TEST & BALANCE (can also use SETTINGS > RTU OPTIONS > BLOWER > SPEEDS)			
	5000 CFM	CFM	Blower CFM during heating.
	4375 CFM	CFM	Blower CFM during high speed cooling (2 compressor) operation.
	1100 CFM	CFM	Blower CFM during low speed cooling (1 compressor) operation.
	1100 CFM	CFM	Blower CFM during ventilation.
	1655 RPM	RPM*	Adjust RPM based on unit static and blower tables to reach target CFM.
<i>*Once all four blower settings are entered, the target (highest of the heating and cooling settings) CFM will be displayed. Once the RPM is saved for the target CFM, all other blower RPM values are set by the Unit Controller according to the field CFM setting..</i>			
SETUP > TEST & BALANCE (can also use SETTINGS > RTU OPTIONS > DAMPER)			
	0%	%	Damper min. position during LOW blower operation.
	0%	%	Damper min. position during HIGH blower operation.
	50%	%	Min. damper % for stage 1 power exhaust operation.
SETTINGS > RTU OPTIONS > EDIT PARAMETERS			
29	101%	%Open	Damper minimum position during G blower operation. (Setting parameter 29 to "101" disables parameter 29 and passes control to parameter 9 or 132)
216	10%	%	Deadband % for stage 1 power exhaust operation.
SETTINGS > RTU OPTIONS > EDIT PARAMETER			
85	0°F	°F	Compressor 1 low temp lockout. Settings lower than 0°F could void warranty.
86	0°F	°F	Compressor 2 low temp lockout. Settings lower than 0°F could void warranty.

TABLE 22
581024-01

Units With Hot Gas Reheat			
RTU Menu > Settings "RTU Options" > Dehumidifier			
Parameter	Factory Setting	Field Setting	Description
105	7		Factory Setting 7: Reheat mode enabled without prerequisite conditions. Controlled by RH sensor (A91) connected to input A55_P298_5 and set point set at parameter 106 (default 60%).

TABLE 23
581037-01

Units With LonTalk Settings
Use menu RTU Menu > Network Integration > Network Setup Wizard > Set "LONTALK"

Configuration ID 1

1 2 3 4 5 6 7 8

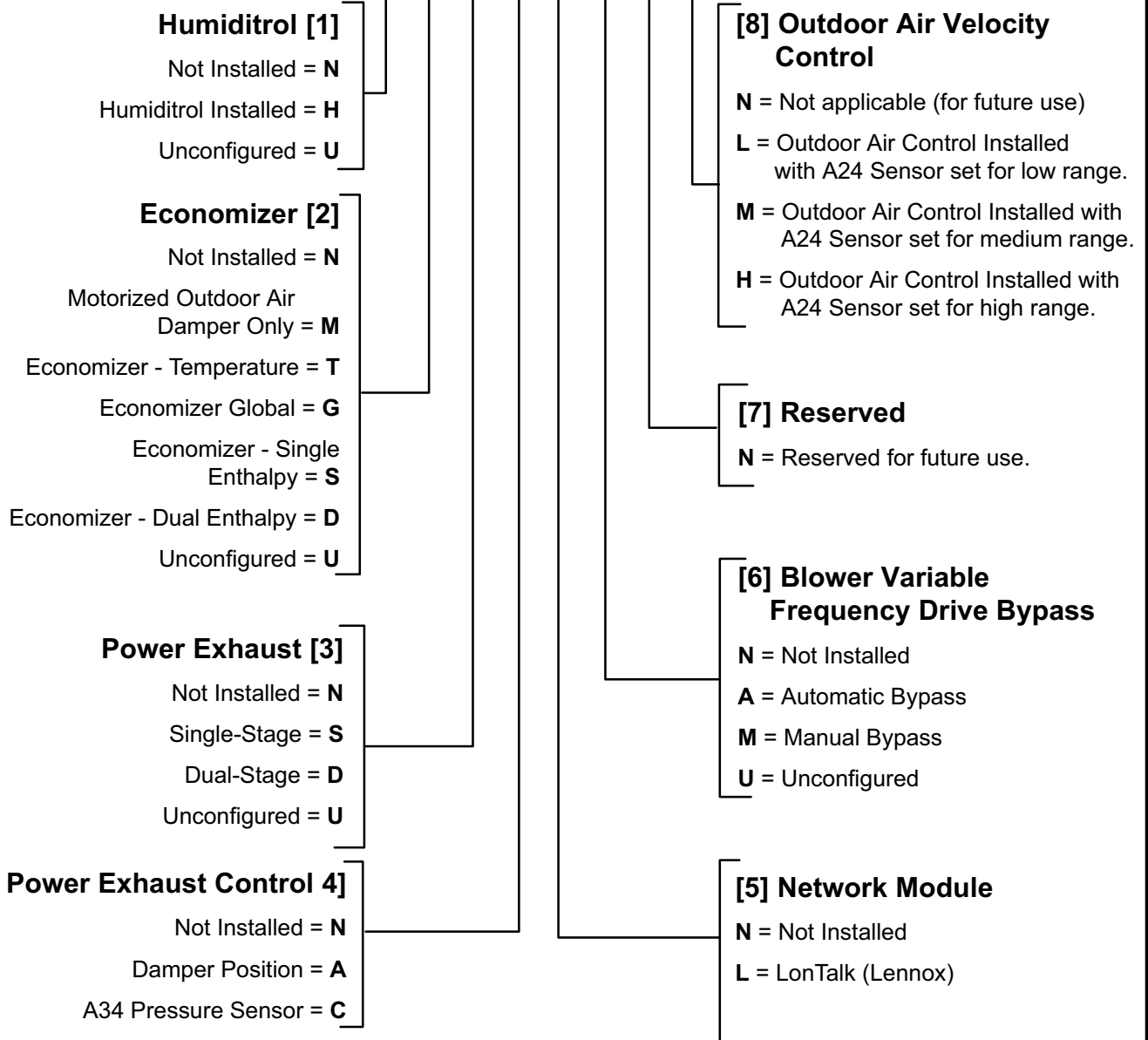
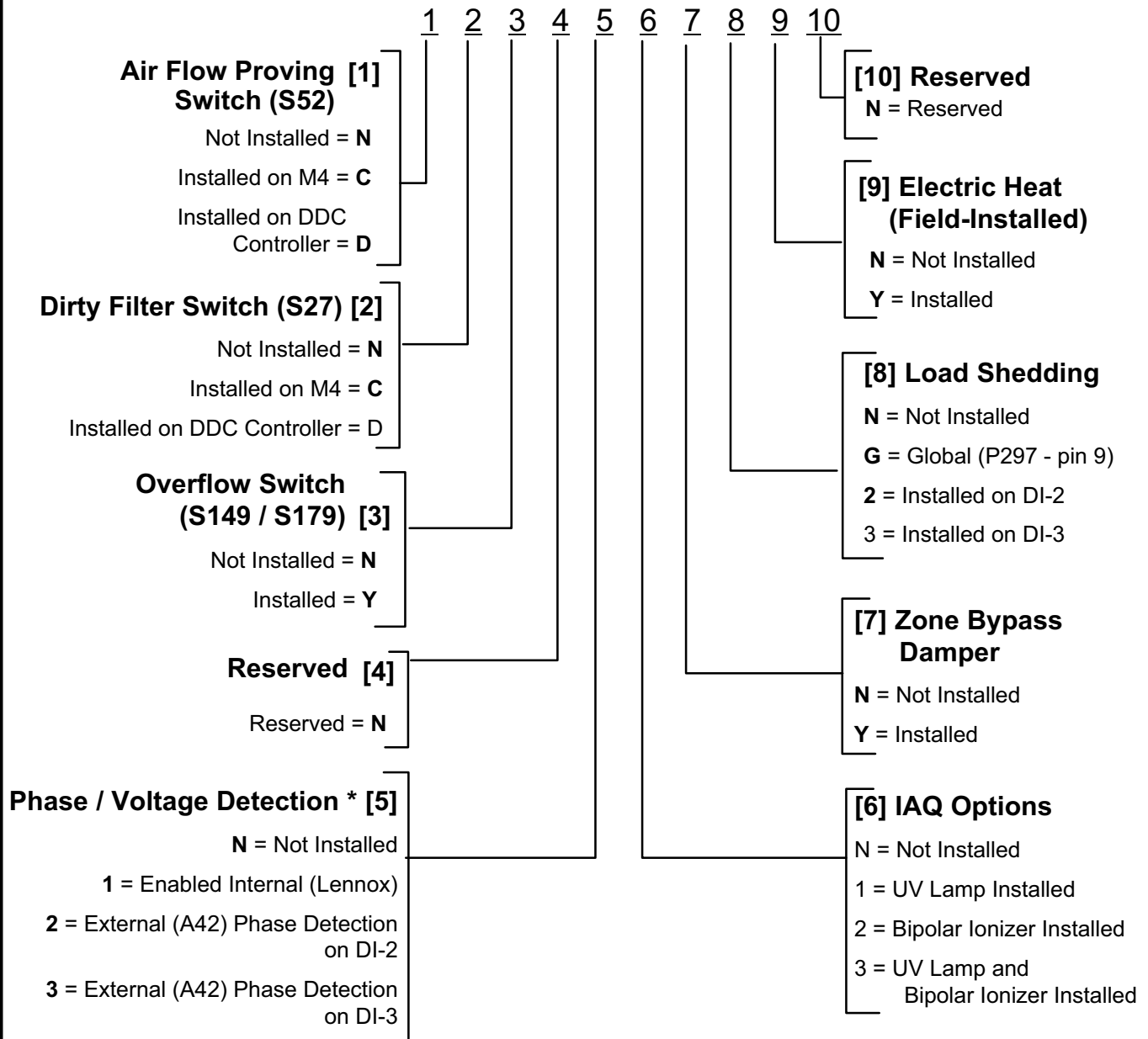

FIGURE 41

Configuration ID 2



* When phase detection and voltage monitoring is enabled and wired incorrectly, the system will go into demand hold status and restart after six minutes.

FIGURE 42

START-UP REPORT

Job Name: _____
 Store No. _____ Start-Up Date: _____
 Address: _____
 City: _____ State: _____
 Start-Up Contractor: _____
 Technician: _____
 Model No.: _____
 Serial No.: _____
 RTU No.: _____ Catalog No.: _____

Inspections and Checks			
Damage?	Yes	No	R22 <input type="checkbox"/> R410A <input type="checkbox"/>
If yes, reported to: _____			
Verify factory and field-installed accessories.			
Check electrical connections. Tighten if necessary.			
Supply voltage: L1-L2 _____ L1-L3 _____ L2-L3 _____			
If unit contains a 208-230/240 volt transformer:			
Check primary transformer tap <input type="checkbox"/>			
Transformer secondary voltage: _____			

Cooling Checks												
Compressor Rotation <input type="checkbox"/> Ambient Temp. _____ Return Air Temp. _____ Supply Air Temp. _____												
	Compressor Amps			Compressor Volts			Pressures		Condenser Fan Amps			CC Heater Amps
	L1	L2	L3	L1-L2	L1-L3	L2-L3	Disch.	Suct.	L1	L2	L3	L1
1												
2												
3												
4												

Blower Checks			
Pulley/Belt Alignment <input type="checkbox"/>	Blower Rotation <input type="checkbox"/>		
Set Screws Tight <input type="checkbox"/>	Belt Tension <input type="checkbox"/>		
Nameplate Amps: _____ Volts: _____			
Motor	Amps	Volts	
	L1 _____	L1-L2 _____	
	L2 _____	L1-L3 _____	
	L3 _____	L2-L3 _____	

Heating Checks - Electric							
Return Air Temp.: _____ Supply Air Temp.: _____							
Limits Operate: <input type="checkbox"/>							
	Amps						
	L1	L2	L3		L1	L2	L3
1				10			
2				11			
3				12			
4				13			
5				14			
6				15			
7				16			
8				17			
9				18			

Heating Checks - Gas		
Fuel type: Nat. <input type="checkbox"/> LP <input type="checkbox"/> Inlet Pressure: _____ in. w.c.		
Return Air Temp.: _____ Supply Air Temp.: _____		
Altitude: _____ Primary Limits Operate: <input type="checkbox"/>		
CO2%: _____		
Gas Valve	Manifold Pressure	
	Low Fire	High Fire
GV1		
GV2		

Control Type

Accessory Checks	
Power Exhaust Amps	
1 _____	2 _____ None <input type="checkbox"/>
Economizer Operation	
Min. Pos. <input type="checkbox"/>	Motor travel full open/close <input type="checkbox"/>