

**COMBUSTION AIR INDUCER  
REPLACEMENT KIT**

**INSTALLATION INSTRUCTIONS FOR COMBUSTION AIR INDUCER REPLACEMENT KIT  
(22F08; LB-112090E) USED ON KG/SG/ZG/LGH024-090 GAS PACKAGED UNITS**

**Shipping and Packing List**

**Package 1 of 1 contains:**

- 1- Combustion air inducer assembly
- 1- Transformer

**Bag assembly containing:**

- 1-Gasket
- 7- #10 Sheet metal screws
- 2- 1/4" QC Piggy-back terminals
- 1- 1/4" QC Terminal
- 3- Wiring diagrams

**Application**

This kit is used to replace 460V, 2-speed combustion air inducers with 230V inducers. A transformer is required for proper operation.

**⚠ WARNING**

**Improper installation, adjustment, alteration, service or maintenance can cause property damage, personal injury or loss of life. Installation and service must be performed by a licensed professional HVAC installer or equivalent, service agency, or the gas supplier**

**Install and Wire T3 Transformer**

1. Disconnect all power and shut off gas supply to unit.
2. Open the control and heat section access panels. See figure 1, 2, or 3.
3. Install the supplied T3 transformer as shown in figure 4, 5, 6, or 7.
4. Connect wiring as shown in each figure. If no space is available on K1 contactor, re-terminate the transformer leads using the supplied piggy-back terminals.

**⚠ CAUTION**

**As with any mechanical equipment, contact with sharp sheet metal edges can result in personal injury. Take care while handling this equipment and wear gloves and protective clothing.**

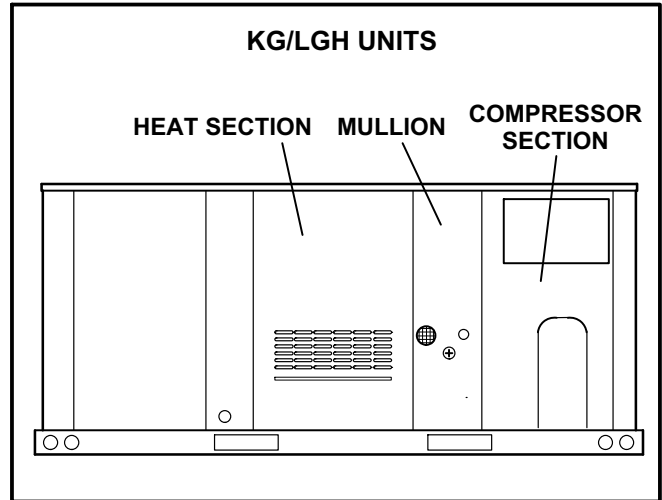


FIGURE 1

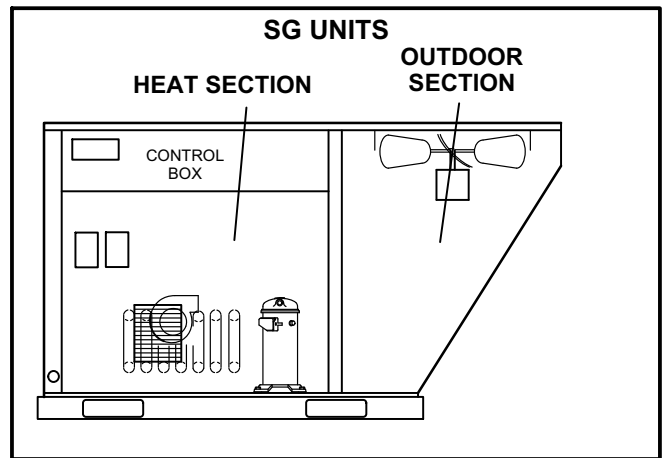


FIGURE 2

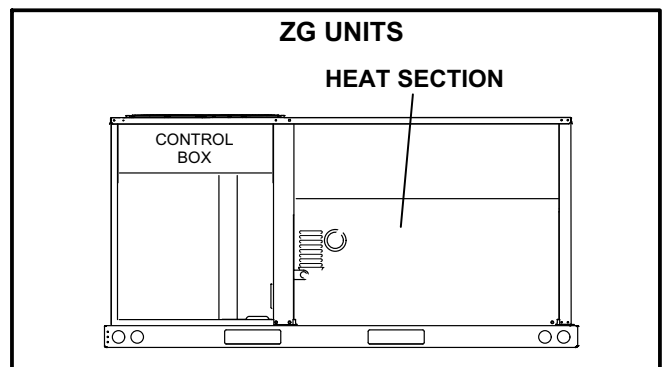
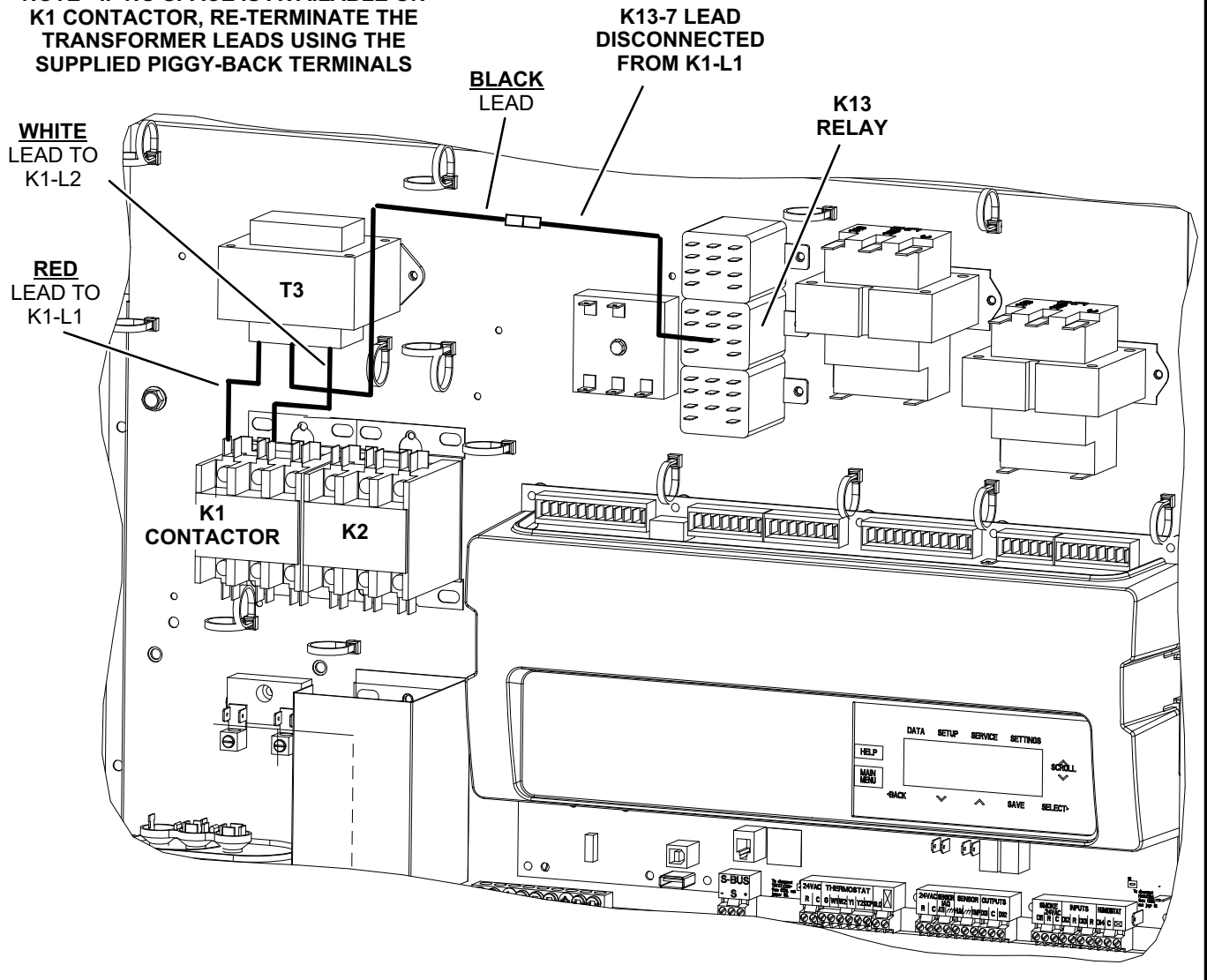


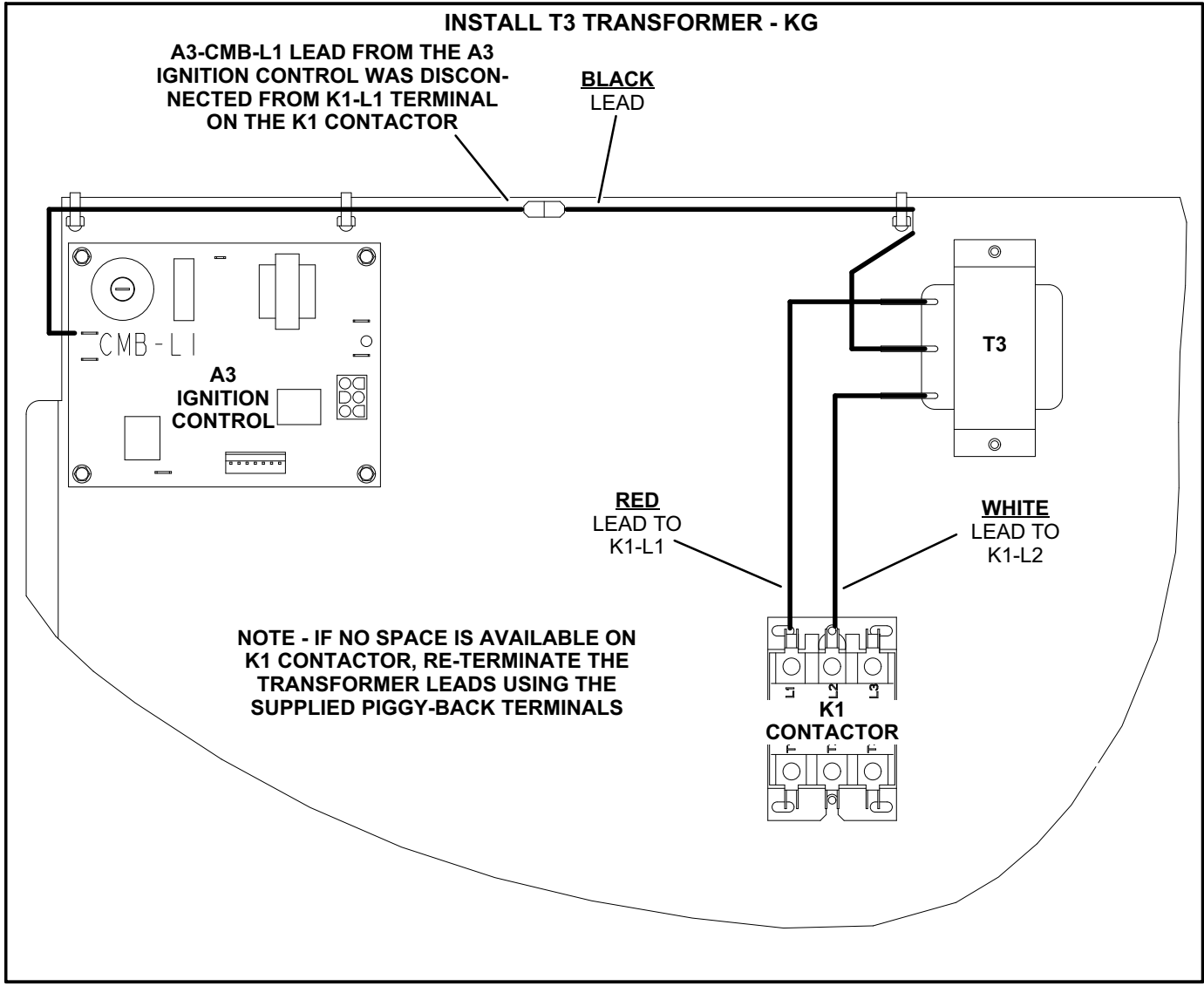
FIGURE 3

### INSTALL T3 TRANSFORMER - LGH

**NOTE - IF NO SPACE IS AVAILABLE ON K1 CONTACTOR, RE-TERMINATE THE TRANSFORMER LEADS USING THE SUPPLIED PIGGY-BACK TERMINALS**



**FIGURE 4**

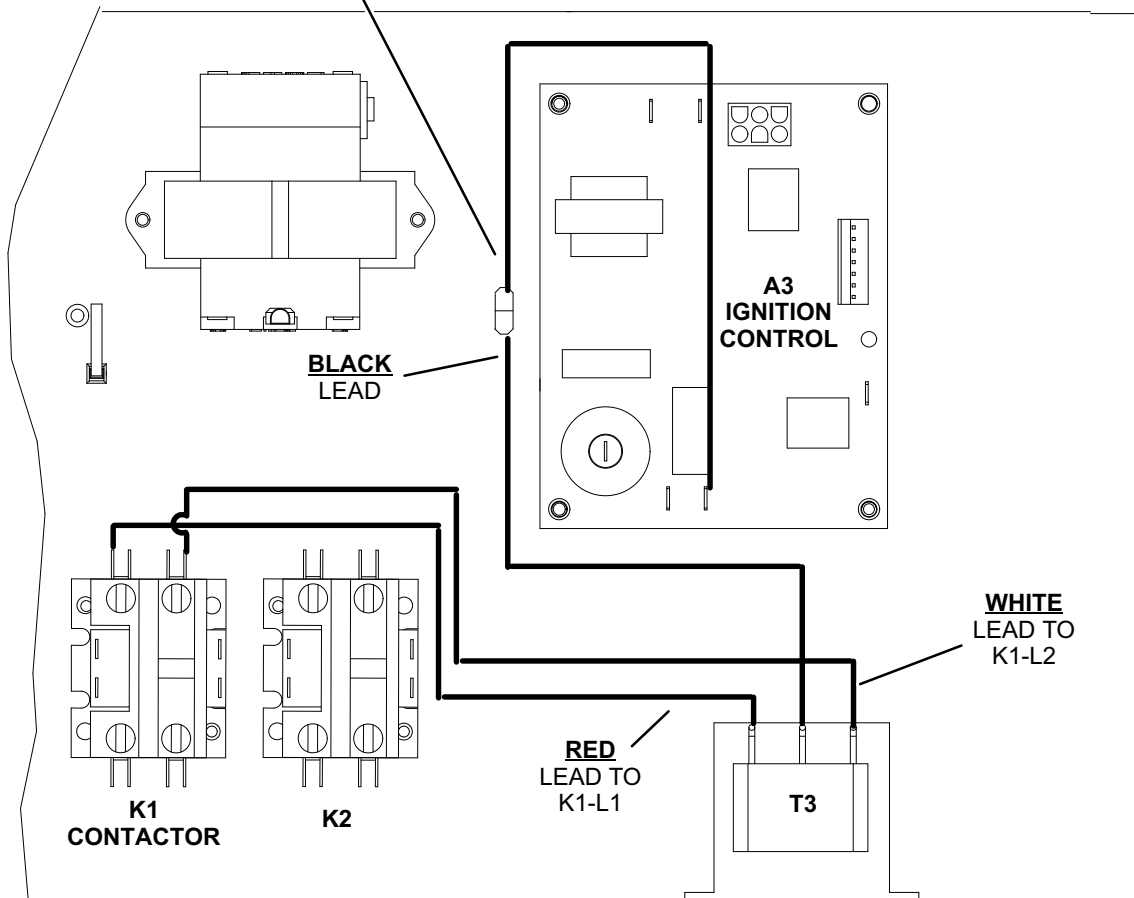


**FIGURE 5**

**INSTALL T3 TRANSFORMER - ZG**

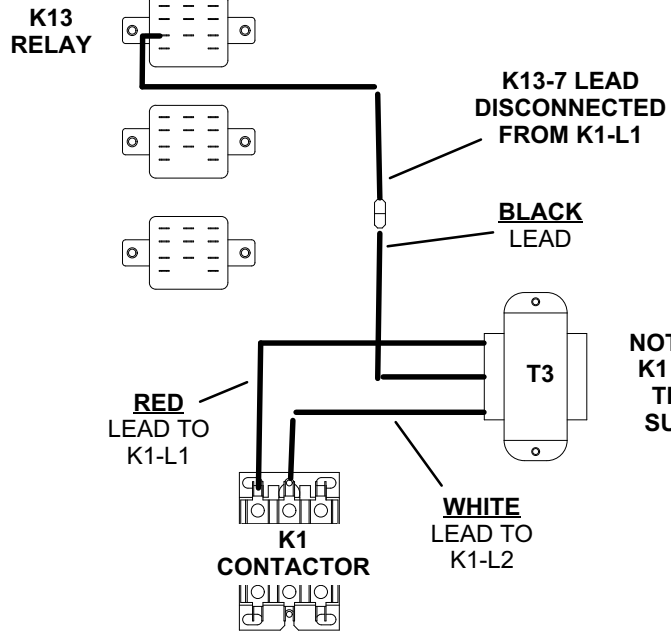
**A3-CMB-L1 LEAD FROM THE A3  
IGNITION CONTROL WAS DISCON-  
NECTED FROM K1-L1 TERMINAL  
ON THE K1 CONTACTOR**

**NOTE - IF NO SPACE IS AVAILABLE ON  
K1 CONTACTOR, RE-TERMINATE THE  
TRANSFORMER LEADS USING THE  
SUPPLIED PIGGY-BACK TERMINALS**

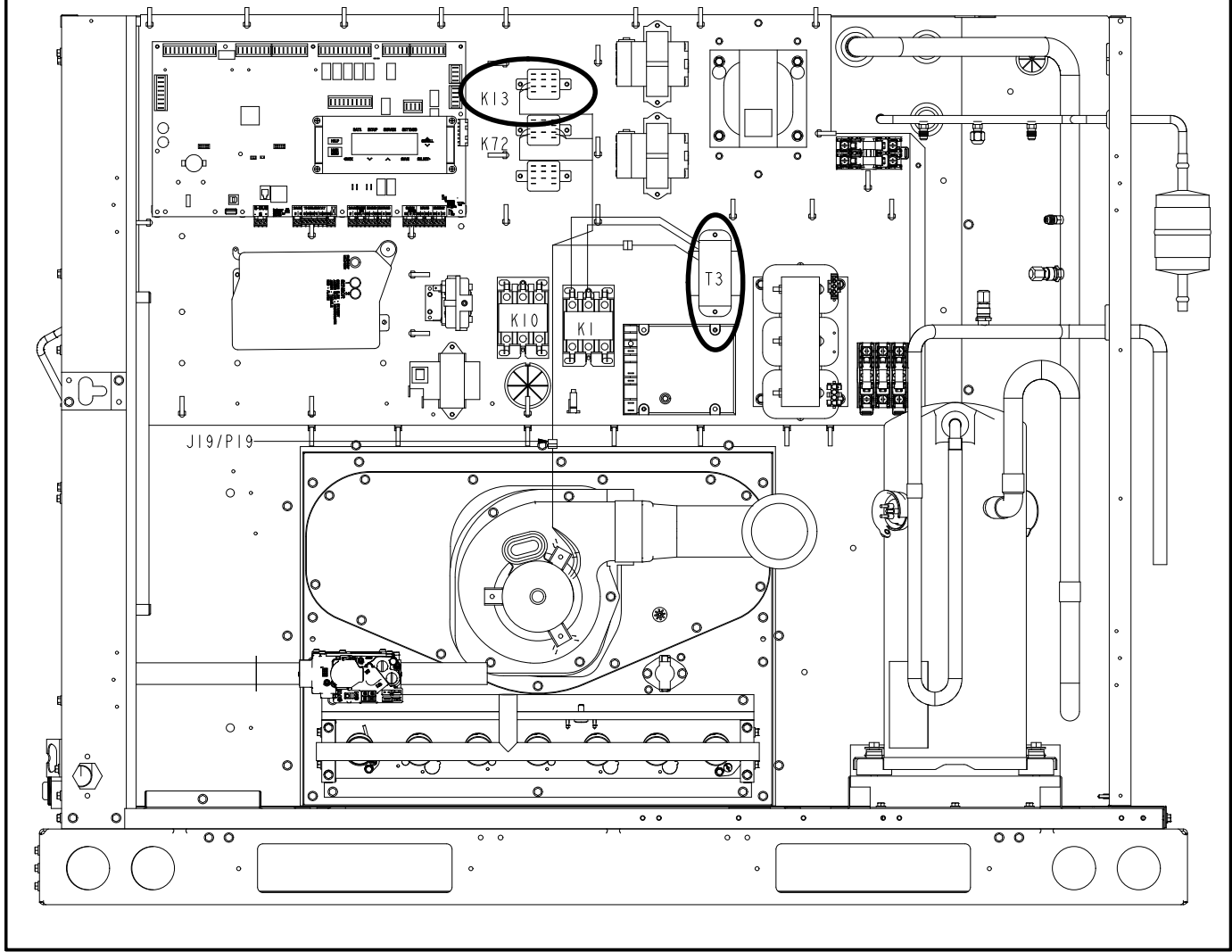


**FIGURE 6**

### INSTALL T3 TRANSFORMER - SG



**NOTE - IF NO SPACE IS AVAILABLE ON K1 CONTACTOR, RE-TERMINATE THE TRANSFORMER LEADS USING THE SUPPLIED PIGGY-BACK TERMINALS**



**FIGURE 7**

## Install Combustion Air Inducer

- 1- Disconnect jack/plug from harness routed to combustion air inducer.
- 2- Remove screws securing combustion air inducer to flue box. Remove combustion air inducer. See figure 9.
- 3- Remove flue elbow from combustion air inducer and set aside.
- 4- Fit flue elbow onto replacement combustion air inducer.
- 5- Install replacement combustion air inducer and gasket. See figure 8. Secure with screws provided in kit.

- 6- Connect jack/plug to combustion air inducer.
- 7- Replace heat access panel and connect power and gas. Start unit as shown in unit installation instructions.

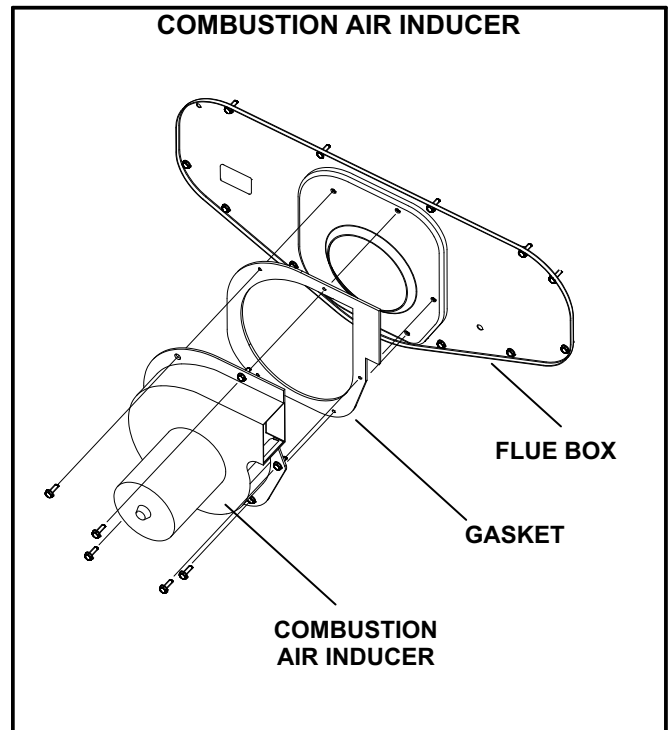


FIGURE 8

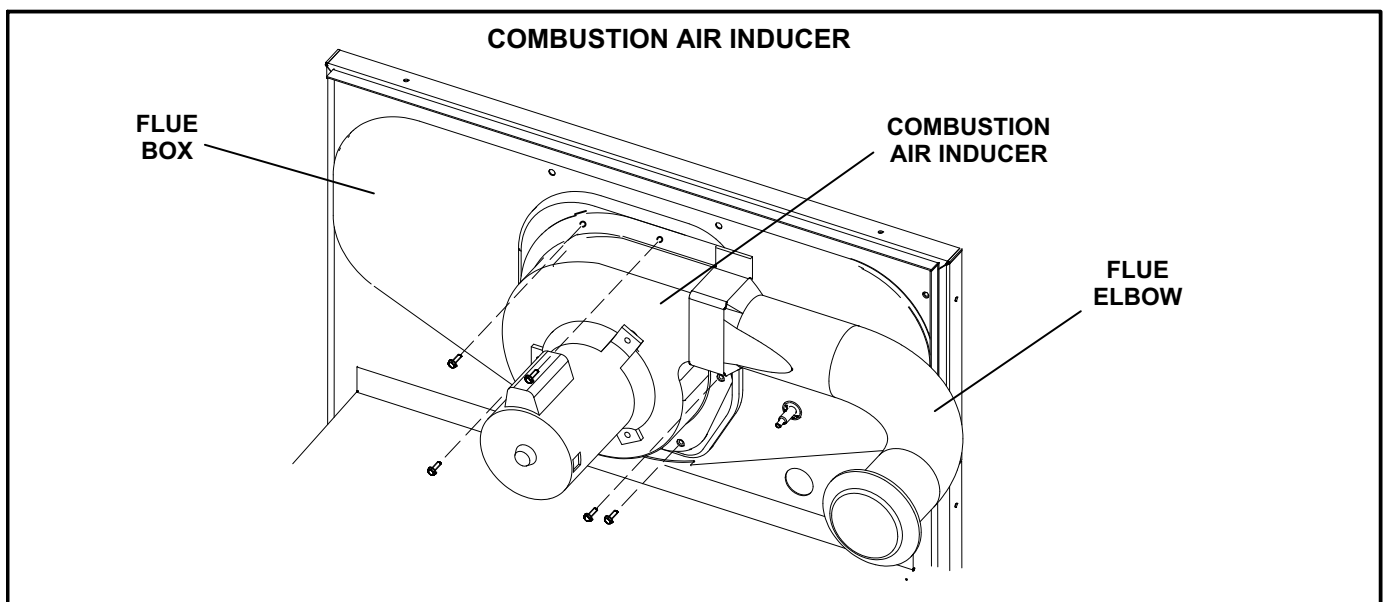


FIGURE 9