

# GAS UNITS KITS & ACCESSORIES

508204-01  
07/2021

## REPLACEMENT HEAT EXCHANGER

### INSTALLATION INSTRUCTIONS FOR REPLACEMENT HEAT EXCHANGER KITS FOR USE WITH 80% EFFICIENCY DOWNFLOW ULTRA-LOW NOX FURNACES

#### **⚠ WARNING**

Improper installation, adjustment, alteration, service or maintenance can cause property damage, personal injury or loss of life. Installation and service must be performed by a licensed professional HVAC installer (or equivalent), service agency or the gas supplier.

#### **⚠ WARNING**

Disconnect power before servicing unit.

#### **⚠ CAUTION**

As with any mechanical equipment, contact with sharp sheet metal edges can result in personal injury. Take care while handling this equipment and wear gloves and protective clothing.

#### Shipping and Packing List

**Package 1 of 1 contains the following:**

- 1 - Heat exchanger assembly

#### Application

See tables 1 for unit capacities, cabinet width and corresponding replacement kits.

**TABLE 1**  
**Two-Stage Furnaces**

Unit Capacities	Cabinet Width	Replacement Kit No.	Replacement Catalog No.
060	B - 17-1/2"	615544-17	22H88
080	C - 21"	615544-18	22H89

#### Installation

Refer to figure 2 as you disassemble the the unit. Place papers or protective covering in front of the furnace before removing the heat exchanger assembly.

- 1 - Turn off both electrical and gas power supplies to furnace.
- 2 - Remove flue pipe and top cap if necessary from the unit.
- 3 - Label the wires from gas valve, rollout switch, primary limit switch and make-up box then disconnect them.
- 4 - Remove the screws that secure the combustion air inducer to the collector box.
- 5 - Disconnect gas supply piping. Remove the air fuel / intake assembly.
- 6 - Remove screws from both sides, top and bottom of vestibule panel.
- 7 - Remove heat exchanger. It may be necessary to spread cabinet side to allow more room. If so, remove five screws from the left side or right side of cabinet. See figure 1.

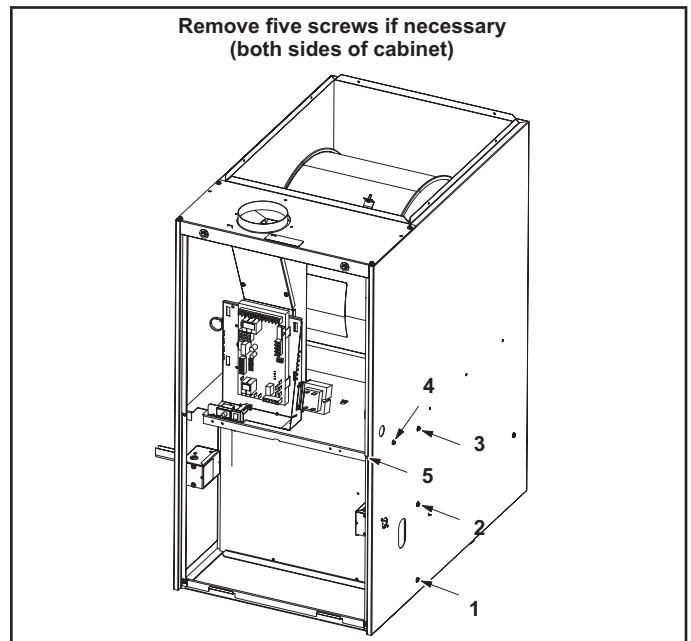

**FIGURE 1**

**HEAT EXCHANGER REMOVAL**  
(Two-Stage Shown)

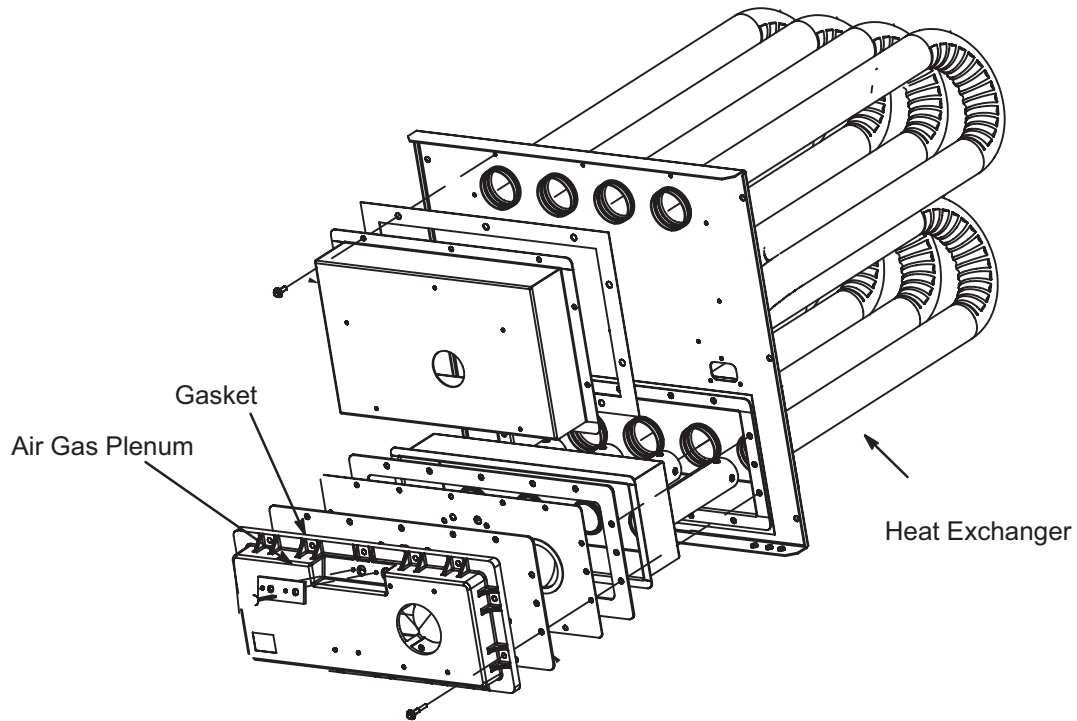

**FIGURE 2**

- 8 - Vinspect the combustion air inducer. If the assembly is clean move to the next step. If necessary, use a wire brush to clean. Use compressed air to clean off debris and any rust.
- 9 - Reinstall heat exchanger in vestibule. (Replace the five screws in the cabinet from step 7 (if removed).
- 10 - Re-install the air / fuel assembly.
- 11 - Reconnect all wires.
- 12 - Reconnect top cap and vent pipe to combustion air inducer outlet.
- 13 - Reconnect gas supply piping.
- 14 - Turn on power and gas supply to unit.
- 15 - Set thermostat and check form proper operation.

**⚠ CAUTION**

Some soaps used for leak detection are corrosive to certain metals. Carefully rinse piping thoroughly after leak test has been completed. Do not use matches, candles, flame or other sources of ignition to check for gas leaks.

- 16 - Check all piping connections, factory and field, for gas leaks. Use leak detector solution or other preferred means.
- 17 - If a leak is detected, shut gas and electricity off and repair leak. Repeat until no leaks are detected.
- 18 - Replace access panel.