



©2022 Lennox Industries Inc.
Dallas, Texas, USA

CARBON DIOXIDE (CO₂) SENSOR KIT



INSTALLATION INSTRUCTIONS FOR CARBON DIOXIDE (CO₂) SENSOR (23V86 and 23V87)

! IMPORTANT

Improper installation, adjustment, alteration, service or maintenance can cause personal injury, loss of life, or damage to property.

Installation and service must be performed by a licensed professional installer (or equivalent) or a service agency.

Shipping and Packing List

Check contents for shipping damage. Receiving party should contact the last carrier immediately if shipping damage is found.

Package list for either catalog number contains the following:

Description	Quantity
CO ₂ Sensor: Circuit Board and Backplate	1
Cover	1
Mounting Screws	2
Set Screws	2
Installation Instruction (wiring diagrams included)	1

Options

CO₂ Wall Mount, White Case, No Display (23V86)

CO₂ Duct Mount, Black Case, No Display (23V87)

! IMPORTANT

These instructions are intended as a general guide and do not supersede local codes in any way. Authorities having jurisdiction should be consulted before installation.

Installation

MOUNTING BRACKET AND SENSOR

1. Make the appropriate wiring preparations.
2. Use the mounting bracket as a template to mark mounting holes or mount to a junction box.
3. Run the wiring through the backplate and make necessary wire connections.
4. Mount the cover on the sensor. Secure the cover to the sensor backplate with the two provided set screws using a 1/16" hex driver.

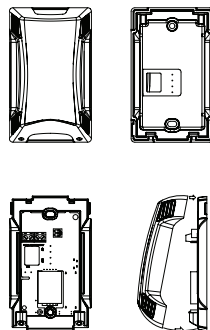

WIRING INSTRUCTIONS

The location and connections to the Lennox rooftop units with the unit controller are shown in figures 1 and 2. Wire from sensor terminal **COM** should be spliced to provide ground and signal common.

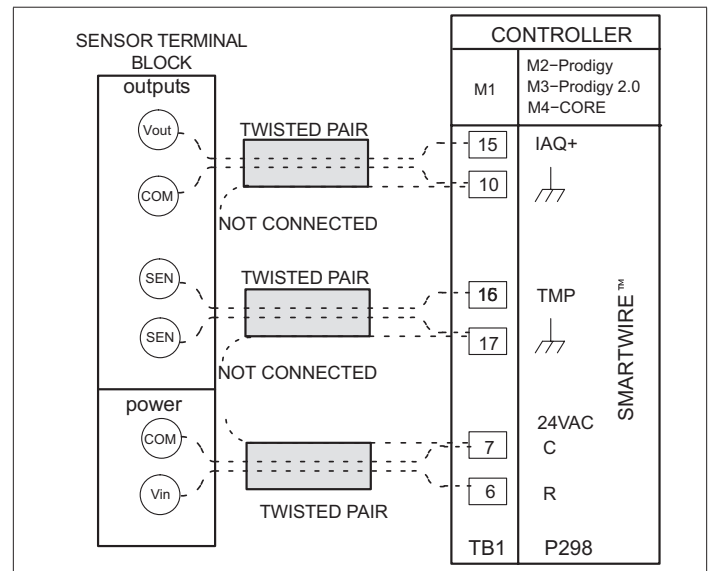

Figure 1. Field Wiring - 150' (46m) or Shorter Runs

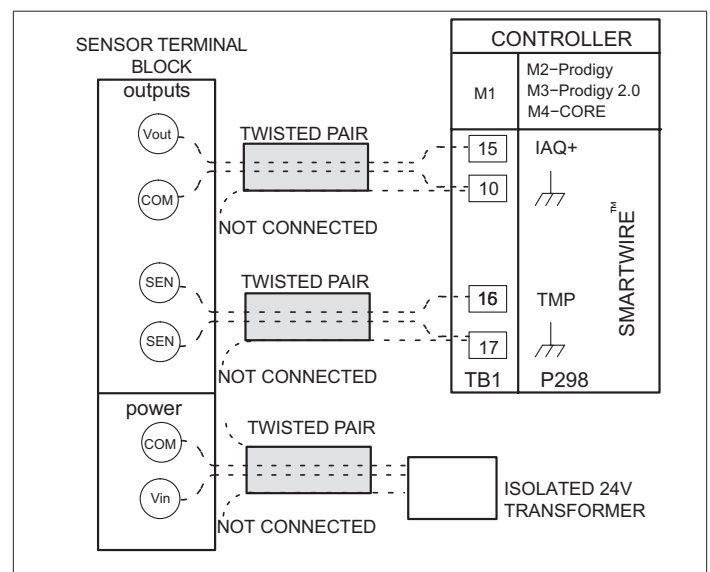

Figure 2. Field Wiring - 150' (46m) or Longer Runs

The connections to the Lennox rooftop units without the unit controller are shown in figure 3.

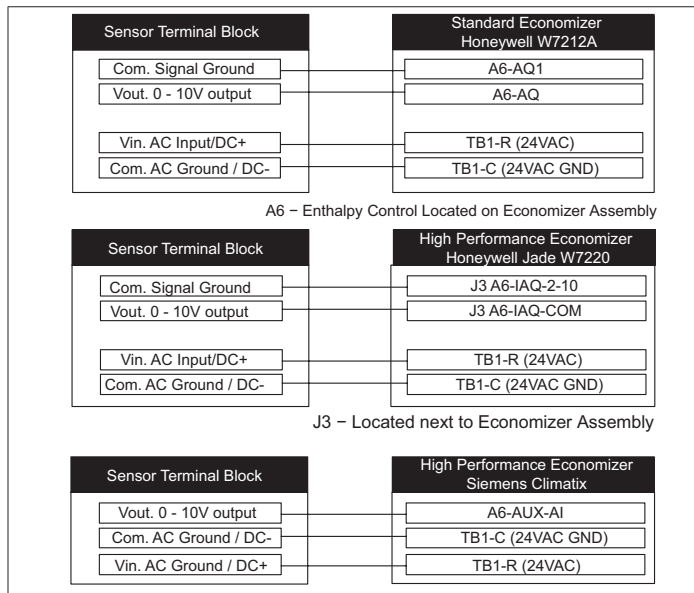

Figure 3. Field Wiring for KC/KG/KH, ZC/ZG/ZH and ELA units without Unit Controller

For applications that require the Lennox CO₂ sensor interface to a non-Lennox controller, please refer to controller manufacturer's instructions.

- Use 18 AWG copper wire.
- Data Logging: If data logging is desired, the output terminal (4–20 mA) may be used with a field-provided data logging device.

ABC LOGIC™ SELF CALIBRATION SYSTEM

This feature allows the sensor to continually recalibrate itself when the indoor CO₂ concentrations drop to outside levels while the building is unoccupied. A building must be unoccupied for 4 hours or more for this self-calibration system to operate properly. Under these conditions, ABC Logic should maintain sensor calibration over the lifetime of the sensor. The ABC Logic should be turned OFF where a building is continuously occupied 24 hours per day, or where there could be significant sources of non-occupant related CO₂ such as greenhouses, breweries and other industrial and food processing applications.

Specifications

Table 1. Specifications

Specification	Description
Sensing Method	Non-dispersive infrared (NDIR) absorption and ABC Logic self calibration algorithm
Measurement Range	0–2000 ppm (0 ppm = 0V, 4mA)
Accuracy	± 40 ppm and ± 3% of reading (@ 15–35°C; 20–70% RH and 101.3 kPa)
Stability	< 2% of FS over life of sensor (15 yr typical)
Warm-up Time	< 1 minutes (operational) 15 minutes (max accuracy)
Operating Conditions	0 – 50°C (32 – 122°F) 0 – 95% RH, non-condensing.
Storage Conditions	–40 – 158°F (–40 – 70°C)
Output (Analog)	0 – 10V (resistive load greater than 5000 ohms) & 4 – 20 mA (RL max 500 ohms) available simultaneously
Power Supply Requirements	24 VAC +/-20%, 50/60 Hz
Temperature Dependence	+/- 0.2% FS/°C (+/- 0.1% FS/°F)
Pressure Dependence	+ 1.6% reading per kPa (deviation from standard pressure 101.3 kPa)
Certifications	EMC Directive 2014/30/EC RoHS Directive 2011/65/EU
Signal Update	Every 2 seconds.
Flammability Classification	UL94-HB
Thermistor Type	NTC 10 K ohm thermistor with 1.3 K ohm resistor in series.
Power Consumption	3 VA for 24 VAC, 3W for 24 VDC (peak); <0.9W (average)

This product is covered by one or more of the following patents:

5,650,624 / 5,721,430 / 5,444,249 / 5,747,808 / 5,834,777 / 5,163,332 / 5,340,986 / 5,502,308 / 6,344,798 / 6,023,069 / 5,370,114 / 5,601,079 / 5,691,704 / 5,767,776 / 5,966,077 / 6,107,925 / 5,798,700 / 5,945,924 / 5,592,147 / 6,255,653 / 6,250,133 / 6,285,290