



L SERIES™

090, 102, 120 AND 150 MODELS
"LCA" PACKAGED COOLING & ELECTRIC HEAT
"LGA" PACKAGED COOLING & GAS HEAT
"LHA" PACKAGED HEAT PUMP

LCA/LGA/LHA
LCA/LGA - 8.5, 10.0 & 12.0 Ton
(29.9, 35.2 & 42.2 kW)
LHA - 7.5 & 10.0 Ton
(26.4 & 35.2 kW)

*Net Cooling Capacity - 96 500 to 132 900 Btuh (28.3 to 38.9 kW) (24 300 to 33 500 kcal)
Gas Output Heating Capacity - 92 300 and 166 900 Btuh (27.0 and 48.9 kW) (23 300 and 42 100 kcal)
*Heat Pump Heating Capacity 81 400 to 107 600 Btuh (23.8 to 31.5 kW) (20 500 to 27 100 kcal)
Optional Electric Heat - 19 600 to 156 600 Btuh (5.0 to 50.0 kW) (4900 to 39 500 kcal)

Bulletin #490073
May 1996

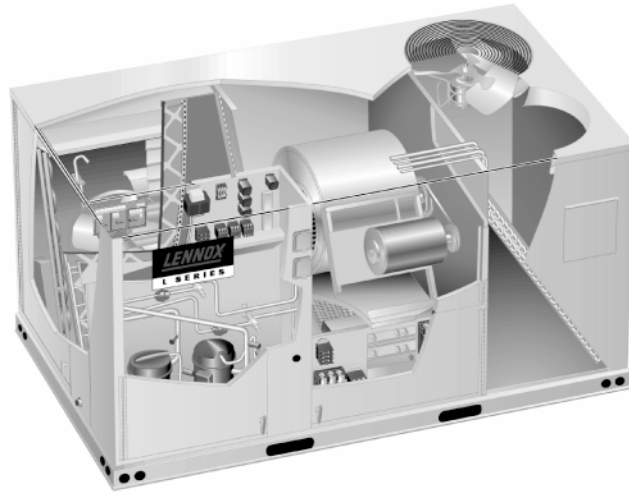

LCA120
(Cooling & Electric Heat)



LGA120
(Cooling & Gas Heat)

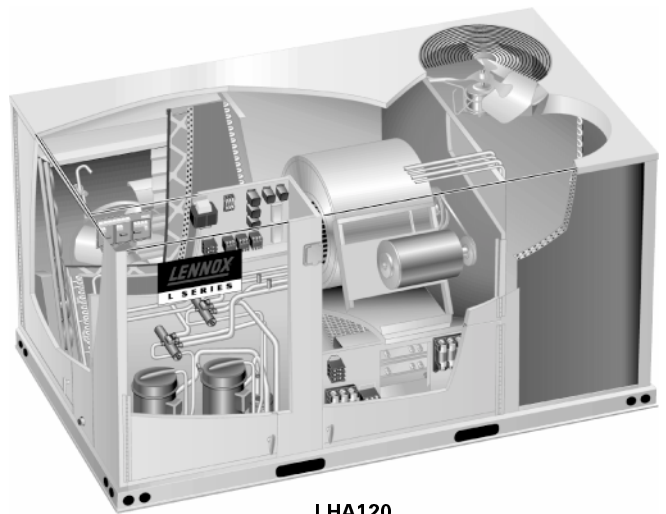

LHA120
(Heat Pump)

Table of Contents

Features	Page 2-3	Field Wiring	Page 15
Factory Installed Only Options	Page 4	Electric Heat Data - LCA102	Page 16
Field Installed Only Accessories	Page 4	Electric Heat Data - LCA120	Page 16
Factory or Field Installed Accessories	Page 5	Electric Heat Data - LCA150	Page 16
Temperature Control Systems	Page 6	Electric Heat Data - LHA090	Page 17
Temperature Control Selection Flowcharts	Page 7	Electric Heat Data - LHA120	Page 17
Model Number Identification	Page 8	Cooling Ratings - LCA/LGA Models	Page 18-19
High Altitude Derate - LGA Models	Page 8	Cooling & Heating Ratings - LHA Models	Page 20-21
Specifications - LCA/LGA102 & 120	Page 9	Blower Data	Page 22-23
Specifications - LCA/LGA150	Page 10	Guide Specifications - LCA Models	Page 24
Specifications - LHA090 & 120	Page 11	Guide Specifications - LGA Models	Page 25
Optional Field Installed Accessories	Page 12	Guide Specifications - LHA Models	Page 26
Weight Data	Page 13	Dimensions - LCA Models	Page 27
Optional Electric Heat Accessories	Page 13	Dimensions - LGA Models	Page 28
Electrical Data - LCA/LGA102 & 120	Page 14	Dimensions - LHA Models	Page 29
Electrical Data - LCA/LGA150	Page 14	Dimensions - Accessories	Page 30-31
Electrical Data - LHA090 & 120	Page 14	Installation Clearances	Page 32

NOTE — Due to Lennox' ongoing commitment to quality, Specifications, Ratings and Dimensions subject to change without notice and without incurring liability.

FEATURES

ALL MODELS

Item	LHA 090	LCA/LGA 102	LCA/LGA/LHA 120	LCA/LGA 150
Air Flow Choice — Bottom (down-flow) or *horizontal (side) supply and return air	Standard	Standard	Standard	Standard
Bottom Power Entry — For electrical and gas lines	Standard	Standard	Standard	Standard
Cabinet — Heavy gauge galvanized steel, fully insulated, powdered enamel paint finish, large removeable access panels, electrical inlets in cabinet base and electric heat end panel (LCA/LHA only), easy access control area with factory installed controls, low voltage terminal strip, unit lifting holes in base rail	Standard	Standard	Standard	Standard
Cabinet Access Panels (Hinged) — 2 compressor/controls/heating area access panels, 1 blower access panel and 1 air filter/economizer access panel hinged with tool-less access handles, gaskets on all edges for tight seal, access panels have steel panel inner liner with insulation sandwiched in-between	Standard	Standard	Standard	Standard
Coil Construction — Copper tube construction, ripple-edged enhanced aluminum fins, flared shoulder tubing connections, silver soldered construction, factory tested, evaporator coil face split with separate circuits, indoor coil drain connection extends outside of unit cabinet	Standard	Standard	Standard	Standard
Compressor Crankcase Heaters	Standard	Standard	Standard	Standard
Filters — Disposable 2 inch (51 mm) pleated commercial grade	Standard	Standard	Standard	Standard
Filter Access — Hinged filter door with tool-less access handles	Standard	Standard	Standard	Standard
Integrated Modular Control (IMC) — Solid-state board contains all controls and control relays to operate unit Built-in Functions Include: <ul style="list-style-type: none"> - Blower On/Off Delay - Built-in Control Parameter Defaults, ensure proper unit operation when power is restored after power failure - Service Relay Output - Defrost Control - Dirty Filter Switch Input - Economizer Control, four modes of operation (outdoor enthalpy, differential enthalpy, temperature and global) - Electric Heat Staging, regulates electric heat during building warm-up - ETM Compatible, various modules (see factory or field installed accessories) - Extensive Unit Diagnostics, (80 diagnostic codes) - Permanent Diagnostic Code Storage - Field Changeable Control Parameters, (65 different parameters) - Gas Valve Delay Between First and Second Stage - Indoor Air Quality Input, monitors CO₂ levels, adjusts economizer dampers as needed (four modes of operation), requires optional field installed Indoor Air Quality (CO₂) Sensor - Low Ambient Controls — Allows unit cooling operation down to 0°F (-17.8°C) - Minimum Run Time - Night Setback Mode, adjusts setpoint, closes outdoor air dampers and operates blower on demand, may be customized for special requirements - Smoke Alarm Mode, (four modes of operation) - “Strike Three” Low Pressure Control, protects system from low suction pressure while eliminating nuisance faults - Thermostat Bounce Delay - Three Digit Display, (Displays: outdoor temperature, supply air temperature, return air temperature, economizer damper position, Indoor Air Quality, control parameters) - Two Stage Thermostat Compatible - Warm-up Mode, (four modes of operation) 	Standard	Standard	Standard	Standard
Outdoor Coil Fans — Polyvinyl Chloride (PVC) coated fan guards furnished	Standard	Standard	Standard	Standard
Outdoor Coil Fan Motors — Overload protected, permanently lubricated, equipped with ball bearings, shaft up, wire basket mount	Standard	Standard	Standard	Standard
Supply Air Blower — Belt drive, forward curved blades with double inlet, blower wheel statically and dynamically balanced, ball bearings, grease fittings furnished, adjustable pulley (allows speed change), blower assembly slides out of unit for servicing	Standard	Standard	Standard	Standard
Supply Air Motor (High Efficiency) — Overload protected, equipped with ball bearings	Standard	Standard	Standard	Standard

*Requires Optional Horizontal Conversion Kit.

FEATURES	LCA MODELS		
Item	LCA102	LCA120	LCA150
Compressors — Reciprocating type	“S” Models	“S” Models	“S” Models
Outdoor Coil Construction — Slab type	Standard	Standard	Standard
Ratings — Rated test conditions are those included in Air Conditioning and Refrigeration Institute (ARI) Standard 210/240-95 while operating at rated voltage and air volumes. Sound rating number rated at test conditions included in Air Conditioning and Refrigeration Institute (ARI) Standard 270-96.	Standard	Standard	Standard
ISO 9002 Quality Standard — Developed in accordance with International Standards Organization (ISO) 9002 quality standards	Standard	Standard	Standard
Refrigeration System — Consists of: compressors, condenser coils and direct drive fans, evaporator coil and belt drive blowers, expansion valves, high capacity driers, high pressure switches, low pressure switches, full refrigerant charge, crankcase heaters, freezestats (prevent coil freeze-up during low ambient operation or loss of air), independent refrigerant circuits (allows staging)	Standard	Standard	Standard

FEATURES	LGA MODELS		
Item	LGA102	LGA120	LGA150
Compressors — Reciprocating type	“S” Models	“S” Models	“S” Models
Outdoor Coil Construction — Slab type	Standard	Standard	Standard
Fan and Limit Controls — Factory installed, 90 second fan “on” time delay, dual limit controls (primary and secondary) with fixed temperature setting	Standard	Standard	Standard
Heat Exchanger — Tubular construction, aluminized steel, life cycle tested	Standard	Standard	Standard
Heating System — Aluminized steel inshot burners, direct spark ignition, electronic flame sensor, redundant automatic dual gas valve with manual shut-off, induced draft blower, flame rollout switch	Standard	Standard	Standard
Ratings — Rated test conditions are those included in Air Conditioning and Refrigeration Institute (ARI) Standard 210/240-95 while operating at rated voltage and air volumes. Sound rating number rated at test conditions included in Air Conditioning and Refrigeration Institute (ARI) Standard 270-96.	Standard	Standard	Standard
ISO 9002 Quality Standard — Developed in accordance with International Standards Organization (ISO) 9002 quality standards	Standard	Standard	Standard
Refrigeration System — Consists of: compressors, condenser coil and direct drive fans, evaporator coil and belt drive blowers, expansion valves, high capacity driers, high pressure switches, low pressure switches, full refrigerant charge, crankcase heaters, freezestats (prevent coil freeze-up during low ambient operation or loss of air) independent refrigerant circuits (allows staging)	Standard	Standard	Standard

FEATURES	LHA MODELS	
Item	LHA090H	LHA120H
Compressors — Copeland® Compliant Scroll™	Standard	Standard
Defrost Control — Furnished on Integrated Modular Control, defrost control provides a defrost cycle, if needed, every 30 or 60 or 90 minutes (adjustable) of compressor “on” time at outdoor coil temperature below 32 °F (0 °C). Pressure switch mounted on outdoor coil vapor line terminates defrost cycle.	Standard	Standard
Outdoor Coil Construction — Formed	Standard	Standard
Ratings — Rated test conditions are those included in Air Conditioning and Refrigeration Institute (ARI) Standard 210/240-95 while operating at rated voltage and air volumes. Sound rating number rated at test conditions included in Air Conditioning and Refrigeration Institute (ARI) Standard 270-96.	Standard	Standard
ISO 9002 Quality Standard — Developed in accordance with International Standards Organization (ISO) 9002 quality standards	Standard	Standard
Refrigeration System — Consists of: compressors, outdoor coils and direct drive fans, indoor coil and belt drive blowers, check and expansion valves (indoor and outdoor), high capacity driers, high pressure switches, low pressure switches, reversing valves, defrost control, full refrigerant charge, crankcase heaters, freezestats (prevent coil freeze-up during low ambient operation or loss of air), independent refrigerant circuits (allows staging)	Standard	Standard

FACTORY INSTALLED ONLY OPTIONS **ALL MODELS**

Item	LHA 090	LCA/LGA 102	LCA/LGA/LHA 120	LCA/LGA 150
Corrosion Protection — Phenolic epoxy coating, applied to condenser coils (with painted base section) and evaporator coils (with painted evaporator base section and painted blower housings), factory applied to either section or both sections	Factory	Factory	Factory	Factory
Dirty Filter Switch — Pressure switch indicates dirty filter, relays information to Integrated Modular Control (furnished with unit)	Factory	Factory	Factory	Factory
*Service Valves — Fully serviceable brass valves installed in discharge and liquid lines	NA	Factory	*Factory	Factory
Smoke Detector — Photoelectric type, factory installed in supply air section or return air section or both sections	Factory	Factory	Factory	Factory

*Not available for LHA heat pump models.

FACTORY INSTALLED ONLY OPTIONS **LGA**

Item	LGA102	LGA120	LGA150
Standard Heat Gas Input — Factory installed (low fire/high fire) 84 500 and 114 000 Btuh (24.8 and 33.4 kW) input two stage heating capacity	Factory	Factory	Factory
High Heat Gas Input — Factory installed (low fire/high fire) 152 500 and 206 000 Btuh (44.7 and 60.4 kW) input two stage heating capacity	Factory	Factory	Factory

FIELD INSTALLED ONLY ACCESSORIES **ALL MODELS**

Item	LHA 090	LCA/LGA 102	LCA/LGA/LHA 120	LCA/LGA 150
Control System — Electro-mechanical Thermostat	Optional	Optional	Optional	Optional
Control System — Electronic Thermostat	Optional	Optional	Optional	Optional
Control System — Honeywell T7300 Thermostat	Optional	Optional	Optional	Optional
DDC Control System — Novar ETM-2050	Optional	Optional	Optional	Optional
Diffusers (Step-Down) — Aluminum grilles, double deflection louvers, large center grille, insulated diffuser box with flanges, hanging rings furnished, interior transition (even air flow), internally sealed (prevents recirculation), adapts to T-bar ceiling grids or plaster ceilings	RTD11-135	RTD11-135	RTD11-135	RTD11-185
Diffusers (Flush) — Aluminum grilles, fixed blade louvers, large center grille, insulated diffuser box with flanges, hanging rings furnished, interior transition (even air flow), internally sealed (prevents recirculation), adapts to T-bar ceiling grids or plaster ceilings	FD11-135	FD11-135	FD11-135	FD11-185
Horizontal Conversion Kit — Two piece duct cover in kit blocks off unit down-flow supply air opening, horizontal return air opening panel (on unit) is moved to block off down-flow return air opening for horizontal applications			56K53	
Horizontal Gravity Exhaust Dampers — Aluminum blade dampers prevent blow back and outdoor air infiltration during off cycle, field installed in return air duct, bird screen furnished			LAGEDH10/15	
Indoor Air Quality (CO₂) Sensor — Monitors CO ₂ levels, reports to Integrated Modular Control (IMC) board which adjusts economizer dampers as needed			18K51	
Transitions (Supply and Return) — Used with diffusers, installs in roof mounting frame, galvanized steel construction, flanges furnished for duct connection, fully insulated	LASRT10/12	LASRT10/12	LASRT10/12	LASRT15
Roof Mounting Frame — Nailer strip furnished, mates to unit, U.S. National Roofing Contractors Approved, shipped knocked down			LARMF10/15-14 — 14 inch (356 mm) height or LARMF10/15-24 — 24 inch (610 mm) height	

FIELD INSTALLED ONLY ACCESSORIES **LGA**

Item	LGA102	LGA120	LGA150
LPG/Propane Kits	Optional	Optional	Optional

FACTORY OR FIELD INSTALLED ACCESSORIES

ALL MODELS

Item	LHA 090	LCA/LGA 102	LCA/LGA/LHA 120	LCA/LGA 150
Blower Proving Switch — Monitors blower operation, locks out unit in case of blower failure	Optional	Optional	Optional	Optional
Economizer — Opposing gear driven recirculated air and outdoor air dampers, plug-in connections to unit, nylon bearings, neoprene seals, 24 volt fully modulating spring return motor, adjustable minimum damper position, damper assembly slides in unit, outdoor air hood must be ordered separately (see below), optional down-flow gravity exhaust dampers available (see below), choice of economizer controls (see below)			LAREMD10/15	
Economizer Control Choice —				
Sensible Control — Furnished on IMC board in unit, uses outdoor air sensor furnished with unit to measure outdoor air temperature and control damper position	Furnished with unit	Furnished with unit	Furnished with unit	Furnished with unit
Outdoor Enthalpy Control — Adjustable enthalpy sensor, senses outdoor air enthalpy for economizer control, 0 to 100% outdoor air, adjustable minimum positioner	Optional	Optional	Optional	Optional
Differential Enthalpy Control — Two solid-state enthalpy sensors allow selection between outdoor air and return air (whichever has lowest enthalpy)	Optional	Optional	Optional	Optional
Global Control — Furnished on IMC board in unit, used with Direct Digital Control (DDC) systems, uses global air sensor to control damper position, determines when to use outdoor air for cooling or set damper at minimum position	Furnished with unit	Furnished with unit	Furnished with unit	Furnished with unit
Down-Flow Gravity Exhaust Dampers — Aluminum blade dampers prevent blow back and outdoor air infiltration during off cycle, bird screen furnished			LAGED10/15	
Outdoor Air Damper Section (Automatic Operation) — Linked mechanical dampers, 0 to 25% outdoor air adjustable, fully modulating spring return damper motor, plug-in connection, installs in unit for down-flow applications, outdoor air hood must be ordered separately (see below)			LAOADM10/15	
Outdoor Air Damper Section (Manual Operation) — Linked mechanical dampers, 0 to 25% (fixed) outdoor air adjustable, installs in unit for down-flow applications, outdoor air hood must be ordered separately (see below)			LAOAD10/15	
Outdoor Air Hood — Required with LAREMD10/15 Economizer, LAOAD10/15 and LAOADM10/15 Outdoor Air Damper Sections, two cleanable aluminum mesh fresh air filters furnished			LAOAH10/15	
Power Exhaust Fans — Install in unit for down-flow applications only with economizer option, provide exhaust air pressure relief, interlocked to run when return air dampers are closed and supply air blower is operating, fan runs when outdoor air dampers are 50% open (adjustable), overload protected, requires optional down-flow gravity exhaust dampers (see above)			LAPEF10/15	

FACTORY OR FIELD INSTALLED ACCESSORIES

LCA/LHA

Item	LHA090	LCA102	LCA/LHA120	LCA150
Electric Heat — Factory or field installed, helix wound nichrome elements, time delay for element staging, individual element limit controls, wiring harness, may be two-stage controlled, requires optional Fuse Block and Terminal Block	Optional	Optional	Optional	Optional
Electric Heat Fuse Block — Mounting screws furnished	Required	Required	Required	Required
Electric Heat LTB2 Terminal Block — Required with electric heat, see Optional Electric Heat Accessories Table	Required	Required	Required	Required

FACTORY OPTIONS OR FIELD INSTALLED ACCESSORIES

LGA

Item	LGA102	LGA120	LGA150
Cold Weather Kit — Electric heater automatically controls minimum temperature in gas burner compartment when temperature is below -40 °F (-40 °C). Allows unit operation of unit down to -60 °F (-50 °C)	Optional	Optional	Optional

OPTIONAL DDC TEMPERATURE CONTROL SYSTEM (Field Installed)**ALL MODELS**

System and Component Description	Catalog No.
NOVAR ETM-2050 KIT	—
Control Module/Blower Proving Switch/Return Air Sensor/Discharge Air Sensor/Wiring Harness — Control module monitors unit operation from different sensors installed in unit, has outputs for 2 stage heat/2 stage cool, automatic or continuous blower operation, economizer damper operation and night setback, features: day/occupied mode with low enthalpy (outdoor air damper open), high enthalpy (outdoor air damper closed) or night/unoccupied mode (outdoor air damper closed), network communication (RS-485, shielded pair twisted wire), local override (1 to 255 minutes), watchdog function, failsafe operation, ETM allows units to be "daisy chained" together (up to 31 units) to be operated from one central location with an "executive" type control processor (onsite or offsite), built-in time delays, built-in unit operating defaults, diagnostic LED's indicate various operating functions, surge suppression protects ETM against lightning or voltage spikes, Blower Proving Switch monitors blower operation and locks out unit in case of blower failure, Return Air Sensor provides input to ETM module to determine heating or cooling operation and number of stages required, Discharge Air Sensor monitors leaving air temperature during unit operation	48K87
Dirty Filter Switch — Senses static pressure increase indicating a dirty filter condition	30K48
Room Temperature Sensor — Provides input to ETM module to determine heating or cooling operation and number of stages required (ordered separately)	97H53
Night Setback Override Switch — Allows momentary override of night setback during unoccupied mode	Field Furnished

OPTIONAL TEMPERATURE CONTROL SYSTEMS (Field Installed)**ALL MODELS**

System and Component Description	Catalog No.
ELECTRO-MECHANICAL THERMOSTAT	—
Thermostat — Two stage heat & two stage cool with dual temperature levers, subbase choice	13F06
Subbase — Manual system switch (Off-Heat-Auto-Cool), fan switch (Auto-On)	13F17
Subbase — Non-switching	13F16
Night Setback Operation — Order components below	—
Heating Thermostat — Single stage heat	13F12
Subbase — Non-switching	13F16
Time Clock — 7 day operation, indicates day and night periods, 2 hour increments, battery back-up	See Price Book for Selection
Time Clock — 24 hour night setback operation, 15 minute increments, battery back-up	See Price Book for Selection
Blower Proving Switch — Monitors blower operation, locks out unit in case of blower failure	30K49
Dirty Filter Switch — Senses static pressure increase indicating a dirty filter condition	30K48
ELECTRONIC THERMOSTAT	—
Electronic Thermostat — Any two stage heat/ two stage cool electronic thermostat may be used.	See Price Book for Selection
Time Clock — 7 day operation, indicates day and night periods, 2 hour increments, battery back-up	See Price Book for Selection
Time Clock — 24 hour night setback operation, 15 minute increments, battery back-up	See Price Book for Selection
Blower Proving Switch — Monitors blower operation, locks out unit in case of blower failure	30K49
Dirty Filter Switch — Senses static pressure increase indicating a dirty filter condition	30K48
HONEYWELL T7300 THERMOSTAT	—
Thermostat — Programmable, internal or optional remote temperature sensing (sensor required), touch sensitive keyboard, automatic switching, °F or °C readout, no anticipator, droop/no droop selection, indicator LED's, hour/day programming, override capabilities, time and operational mode readout, stage status indicators, battery back-up, subbase choice	81G59
Subbase — Selectable staging up to two stage heat & two stage cool, manual system switch (Heat-Off-Auto-Cool), fan switch (Auto-On), indicator LED's, auxiliary relay output for economizer operation	81G60
Sensor — Room temperature	58C92
Sensor — Room temperature with 3 hour override and setpoint adjustment	86G67
Sensor — Return air temperature	27C40
Blower Proving Switch — Monitors blower operation, locks out unit in case of blower failure	30K49
Dirty Filter Switch — Senses static pressure increase indicating a dirty filter condition	30K48

DDC TEMPERATURE CONTROL SELECTION FLOWCHARTS

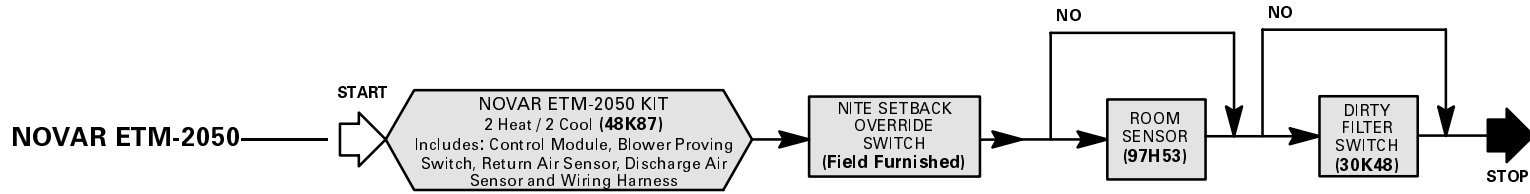

CONVENTIONAL TEMPERATURE CONTROL SELECTION FLOWCHARTS

ELECTRO-MECHANICAL THERMOSTAT

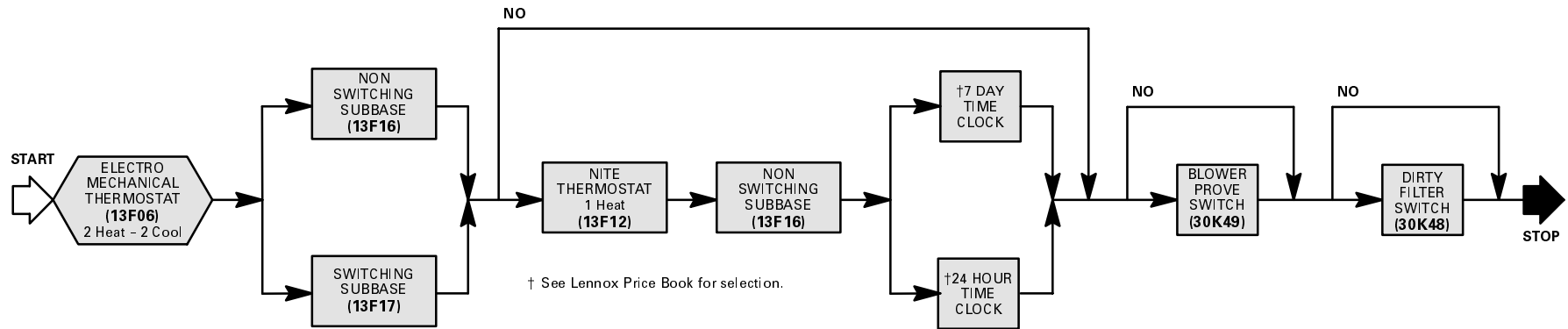

ELECTRONIC THERMOSTAT

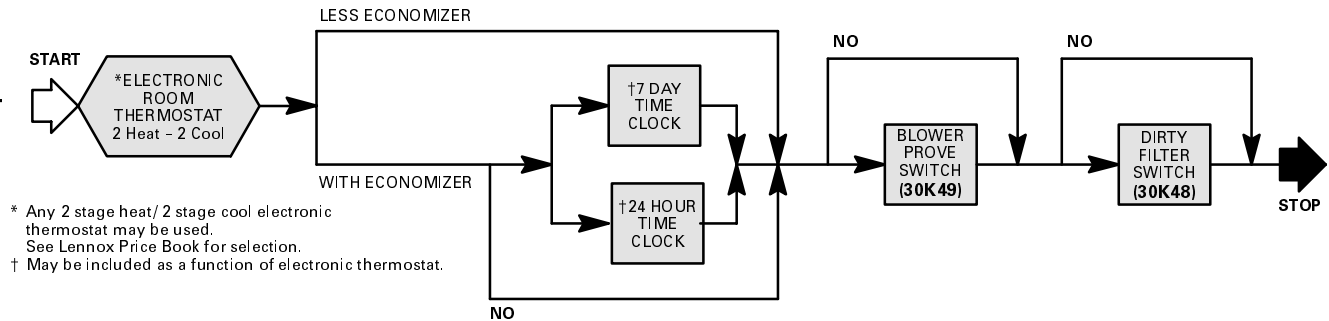

HONEYWELL T7300 THERMOSTAT

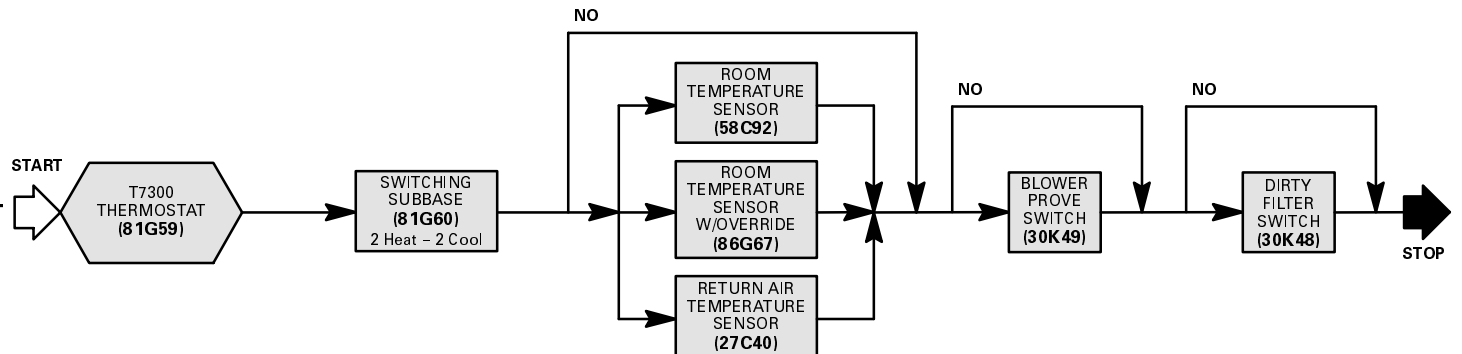

MODEL NUMBER IDENTIFICATION

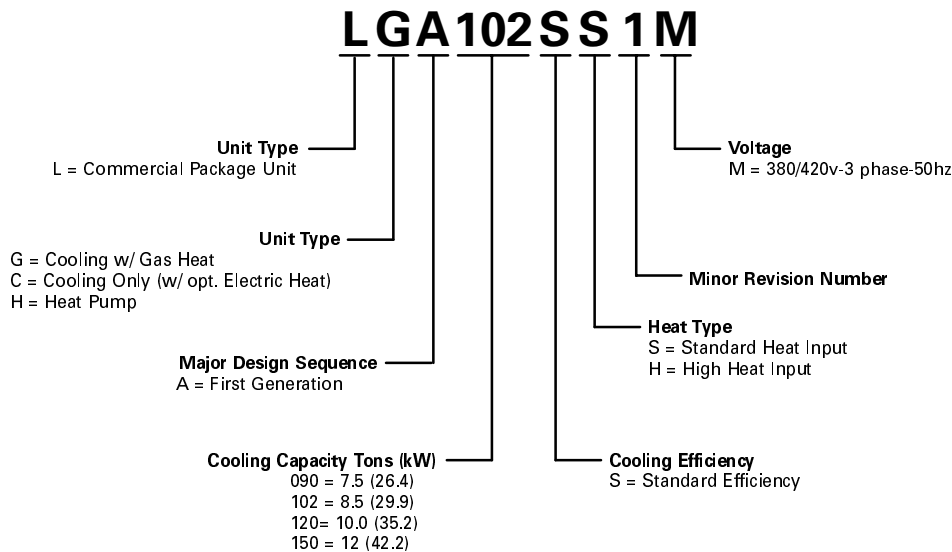

FACTORY INSTALLED OPTIONS

BLOWER MOTORS

- 2 hp (1.5 kW) high efficiency
- 3 hp (2.2 kW) high efficiency
- 5 hp (3.7 kW) high efficiency

*BLOWER DRIVES

- Drive #1 & 3 option w/ 2 hp (1.5 kW) motor
- Drive #2, 4 & 6 option w/ 3 hp (2.2 kW) hi. eff. motor
- Drive #4 & 6 option w/ 5 hp (3.7 kW) motor

*See Blower Performance table for specifications.

TECHNICOAT CORROSION PROTECTION

- Condenser Coils and Base Section
- Evaporator Coil, Base Section and Blower Housing

ECONOMIZER

ECONOMIZER CONTROLS

- Sensible Control
- Outdoor Enthalpy Control
- Differential Enthalpy Control
- Global Control

OUTDOOR AIR DAMPERS

- Manual Control
- Automatic Control

POWER EXHAUST FAN

GRAVITY EXHAUST DAMPERS (Down-Flo Applications Only)

ELECTRICAL

- Single Point Power Supply

HEAT SELECTION

GAS HEAT (Two Stage)

- Standard Heat Input (low fire/high fire)
84 500 and 114 000 Btuh (24.8 and 33.4 kW)
- High Heat Input (low fire/high fire)
152 500 and 206 000 Btuh (44.7 and 60.4 kW)

ELECTRIC HEAT

- 5 kW (090 and 102 models only)
- 12.5 kW
- 25 kW
- 40 kW
- 50 kW (120 and 150 models only)

REFRIGERATION SYSTEM

- Service Valves (Not Available for LHA Models)

DDC CONTROL SYSTEMS

- Novar ETM-2050

DIRTY FILTER SWITCH

BLOWER PROVING SWITCH

SMOKE DETECTORS

- Smoke Detector (Return Air)
- Smoke Detector (Supply Air)

CONDENSATE TRAPS

- PVC or Copper

HIGH ALTITUDE DERATE (LGA Models)

Units may be installed at altitudes up to 2000 feet (610 m) above sea level without any modification. At altitudes above 2000 feet (610 m), units must be derated to match gas manifold pressures shown in table below.

NOTE — This is the only permissible derate for these units.

Altitude - ft. (m)	Gas Manifold Pressure - in. w.g. (kPa)
2001 - 3000 (610 - 915)	2.9 (0.72)
3001 - 4000 (915 - 1220)	2.8 (0.70)
4001 - 5000 (1220 - 1525)	2.7 (0.67)
5001 - 6000 (1525 - 1830)	2.6 (0.65)
6001 - 7000 (1830 - 2135)	2.5 (0.62)
7001 - 8000 (2135 - 2440)	2.4 (0.60)

SPECIFICATIONS — 102 AND 120 SIZES

LCA/LGA

Model Number		LCA/LGA102	LCA/LGA120	
Evaporator Blower and Drive Selection	Blower wheel nominal diameter x width — in. (mm)	(1) 15 x 15 (381 x 381)		
	2 hp (1.5 kW) *Motor and Drives	Motor output — hp (kW)	2 (1.5)	
		Voltage and phase	380/420v-50hz-3 phase with neutral	
		(Drive kit #) rev/min range	(1) 562-764 (3) 739-925 (5) 917-1152	
	3 hp (2.2 kW) *Motor and Drives	Motor output — hp (kW)	3 (2.2)	
		Voltage and phase	380/420v-50hz-3 phase with neutral	
		(Drive kit #) rev/min range	(4) 750-938 (6) 930-1169	
	5 hp (3.7 kW) *Motor and Drives	Motor output — hp (kW)	5 (3.7)	
		Voltage and phase	380/420v-50hz-3 phase with neutral	
(Drive kit #) rev/min range		(2) 561-776 (4) 739-924 (6) 916-1151		
Evaporator Coil	Net face area — sq. ft. (m ²)	10.5 (0.98) total		
	Tube outside diameter — in. (mm) and number of rows	3/8 (9.5) — 3	3/8 (9.5) — 4	
	Fins per inch (m)	14 (551)		
	Drain connection number and size — in. (mm)	(1) 1 (25.4) female pipe thread		
	Expansion device type	Balanced Port Thermostatic Expansion Valve, removeable power head		
Condenser Coil	Net face area — sq. ft. (m ²)	29.3 (2.72) total		
	Tube diameter — in. (mm) and number of rows	3/8 (9.5) — 1 (standard efficiency) or 3/8 (9.5) — 2 (high efficiency)	3/8 (9.5) — 2	
	Fins per inch (m)	20 (787)	15 (591)	
Condenser Fans	Diameter — in. (mm) and number of blades	(2) 24 (610) — 3		
	Total air volume — cfm (L/s)	6665 (3145)		
	Motor output - horsepower (W)	(2) 1/3 (249)		
	Motor rev/min	896		
	Total motor watts	535		
Filters (furnished)	Type of filter	Disposable, commercial grade, pleated		
	Number and size — in. (mm)	(4) 18 x 24 x 2 (457 x 610 x 51)		
Electrical characteristics		380/420v-50hz-3 phase with neutral		

COOLING CAPACITY — 102 AND 120 SIZES

LCA/LGA

Model Number		LCA/LGA102S	LCA/LGA120S
Cooling Ratings	Gross Cooling Capacity — Btuh (kW) (kcal)	96 500 (28.3) (24 300)	115 000 (33.7) (29 000)
	*Net Cooling Capacity — Btuh (kW) (kcal)	93 000 (27.2) (23 400)	109 000 (31.9) (27 500)
	Total Unit Power Input (kW)	9.6	11.9
	Coefficient of Performance - Output/Input	2.81	2.68
	*Energy Efficiency Ratio (Btuh/Watt)	10.0	10.0
	†Integrated Part Load Value (Btuh/Watt)	9.8	9.8
●Sound Rating Number (db)		87	87
Refrigerant Charge Furnished (HCFC-22)	Circuit 1	7 lbs. 4 oz. (3.28 kg)	9 lbs. 8 oz. (4.31 kg)
	Circuit 2	7 lbs. 4 oz. (3.28 kg)	9 lbs. 8 oz. (4.31 kg)

*Rated test conditions are those included in Air Conditioning and Refrigeration Institute (ARI) Standard 360-86 while operating at rated voltage and air volumes.
Cooling Ratings: 95°F (35°C) outdoor air temperature and 80°F (27°C) db/67°F (19°C) wb entering evaporator air; minimum external duct static pressure.
 †Integrated Part Load Value rated at 80°F (27°C) outdoor air temperature.
 ●Sound rating number rated at test conditions included in Air Conditioning and Refrigeration Institute (ARI) Standard 270-96.
 NOTE — Net capacity includes evaporator blower motor heat deduction. Gross capacity does not include evaporator blower motor heat deduction.

GAS HEATING CAPACITY — 102 AND 120 SIZES

LGA

Model Number		LGA102		LGA120	
Heat Input Type		Standard	High	Standard	High
Two Stage Heating Capacity (Natural or LPG/Propane Gas at Sea Level)	Input (low) — Btuh (kW) (kcal)	84 500 (24.8) (21 300)	152 500 (44.7) (38 400)	84 500 (24.8) (21 300)	152 500 (44.7) (38 400)
	Output (low) — Btuh (kW) (kcal)	67 500 (19.8) (17 000)	122 000 (35.8) (30 700)	67 500 (19.8) (17 000)	122 000 (35.8) (30 700)
	Input (High) — Btuh (kW) (kcal)	114 000 (33.4) (28 700)	206 000 (60.4) (51 900)	114 000 (33.4) (28 700)	206 000 (60.4) (51 900)
	Output (High) — Btuh (kW) (kcal)	92 300 (27.0) (23 300)	166 900 (48.9) (42 100)	92 300 (27.0) (23 300)	166 900 (48.9) (42 100)
	Thermal Efficiency	81.0%	81.0%	81.0%	81.0%
Gas Supply Connections npt — in.	Natural	3/4			
	*LPG/Propane	3/4			
Recommended Gas Supply Pressure — wc. in. (kPa)	Natural	7 (1.7)		7 (1.7)	
	*LPG/Propane	11 (2.7)		11 (2.7)	

*For LPG/Propane units a field conversion kit is required and must be ordered extra.

SPECIFICATIONS — 150 SIZE

LCA/LGA

Model Number		LCA/LGA150	
Evaporator Blower and Drive Selection	Blower wheel nominal diameter x width — in. (mm)		(1) 15 x 15 (381 x 381)
	2 hp (1.5 kW) *Motor and Drives	Nominal motor output — hp (kW)	2 (1.5)
		Voltage and phase	380/420v-50hz-3 phase with neutral
		(Drive kit #) rev/min range	(1) 562-764 (3) 739-925 (5) 917-1152
	3 hp (2.2 kW) *Motor and Drives	Nominal motor output — hp (kW)	3 (2.2)
		Voltage and phase	380/420v-50hz-3 phase with neutral
		(Drive kit #) rev/min range	(4) 750-938 (6) 930-1169
	5 hp (3.7 kW) *Motor and Drives	Nominal motor horsepower (kW)	5 (3.7)
		Voltage and phase	380/420v-50hz-3 phase with neutral
(Drive kit #) rev/min range		(2) 561-776 (4) 739-924 (6) 916-1151	
Evaporator Coil	Net face area — sq. ft. (m ²)		10.5 (0.98) total
	Tube diameter — in. (mm) and number of rows		3/8 (9.5) — 3
	Fins per inch (m)		14 (551)
	Drain connection number and size — in. (mm) fpt		(1) 1 (25.4)
	Expansion device type		Balanced Port Thermostatic Expansion Valve, removeable power head
Condenser Coil	Net face area — sq. ft. (m ²)		29.3 (2.72) total
	Tube diameter — in. (mm) and number of rows		3/8 (9.5) — 2
	Fins per inch (m)		20 (787)
Condenser Fans	Diameter — in. (mm) and number of blades		(2) 24 (610) — 3
	Total Air volume — cfm (L/s)		8000 (3775)
	Motor output - horsepower (W)		(2) 1/3 (249)
	Motor rev/min		1075
	Total Motor watts		700
Filters (furnished)	Type of filter		Disposable, commercial grade, pleated
	Number and size — in. (mm)		(4) 18 x 24 x 2 (457 x 610 x 51)
Electrical characteristics		380/420v-50hz-3 phase with neutral	

COOLING CAPACITY — 150 SIZE

LCA/LGA

Model Number		LCA/LGA150S	
Cooling Ratings	Gross Cooling Capacity — Btuh (kW) (kcal)		132 900 (38.9) (33 500)
	*Net Cooling Capacity — Btuh (kW) (kcal)		126 000 (36.9) (31 800)
	Total Unit Power Input (kW)		13.9
	Coefficient of Performance - Output/Input		2.66
	*Energy Efficiency Ratio (Btuh/Watt)		10.0
	†Integrated Part Load Value (Btuh/Watt)		9.8
●Sound Rating Number (db)		87	
Refrigerant Charge Furnished (HCFC-22)	Circuit 1	12 lbs. 0 oz. (5.44 kg)	
	Circuit 2	12 lbs. 0 oz. (5.44 kg)	

*Rated test conditions are those included in Air Conditioning and Refrigeration Institute (ARI) Standard 360-86 while operating at rated voltage and air volumes. Cooling Ratings: 95°F (35°C) outdoor air temperature and 80°F (27°C) db/67°F (19°C) wb entering evaporator air; minimum external duct static pressure.

†Integrated Part Load Value rated at 80°F (27°C) outdoor air temperature.

●Sound rating number rated at test conditions included in Air Conditioning and Refrigeration Institute (ARI) Standard 270-96.

NOTE — Net capacity includes evaporator blower motor heat deduction. Gross capacity does not include evaporator blower motor heat deduction.

GAS HEATING CAPACITY — 150 SIZE

LGA

Model Number		LGA150	
Heat Input Type		Standard	High
Two Stage Heating Capacity (Natural or LPG/Propane Gas (at Sea Level))	Input (low) — Btuh (kW) (kcal)	84 500 (24.8) (21 300)	152 500 (44.7) (38 400)
	Output (low) — Btuh (kW) (kcal)	67 500 (19.8) (17 000)	122 000 (35.8) (30 700)
	Input (High) — Btuh (kW) (kcal)	114 000 (33.4) (28 700)	206 000 (60.4) (51 900)
	Output (High) — Btuh (kW) (kcal)	92 300 (27.0) (23 300)	166 900 (48.9) (42 100)
	Thermal Efficiency	81.0%	81.0%
Gas Supply Connections npt — in.	Natural	3/4	
	*LPG/Propane	3/4	
Recommended Gas Supply Pressure — wc. in. (kPa)	Natural	7 (1.7)	
	*LPG/Propane	11 (2.7)	

*For LPG/Propane units a field conversion kit is required and must be ordered extra.

SPECIFICATIONS — 090 AND 120 SIZES

LHA

Model Number		LHA090H	LHA120H	
Cooling Ratings	Gross Cooling Capacity — Btuh (kW) (kcal)	83 900 (24.6) (21 100)	112 400 (32.9) (28 300)	
	*Net Cooling Capacity — Btuh (kW) (kcal)	80 000 (23.4) (20 200)	106 000 (31.1) (26 700)	
	Total Unit Power Input (kW)	7.0	10.2	
	*Energy Efficiency Ratio (Btuh/Watt)	10.0	10.0	
	Coefficient of Performance – Output/Input	3.35	3.04	
	†Integrated Part Load Value (Btuh/Watt)	12.2	11.5	
High Temperature Heating Ratings	*Total Heating Capacity — Btuh (kW) (kcal)	81 400 (23.9) (20 500)	107 600 (31.5) (27 100)	
	Total Unit Power Input (kW)	7.4	9.5	
	Coefficient of Performance – Output/Input	3.37	3.52	
Low Temperature Heating Ratings	*Total Heating Capacity — Btuh (kW) (kcal)	47 000 (13.8) (11 800)	65 100 (19.1) (16 400)	
	Total Unit Power Input (kW)	7.1	8.8	
	Coefficient of Performance – Output/Input	2.10	2.36	
●Sound Rating Number (db)		87	87	
Refrigerant Charge Furnished (HCFC-22)	Circuit 1	12 lbs. 0 oz. (5.4 kg)	12 lbs. 8 oz. (5.7 kg)	
	Circuit 2	10 lbs. 10 oz. (4.8 kg)	12 lbs. 8 oz. (5.7 kg)	
Evaporator Blower and Drive Selection	Blower wheel nominal diameter x width — in. (mm)		(1) 15 x 15 (381 x 381)	(1) 15 x 15 (381 x 381)
	2 hp (1.5 kW) *Motor and Drives	Motor output — hp (kW)	2 (1.5)	
		Voltage and phase	380/420v-50hz-3 phase with neutral	
		(Drive kit #) rev/min range	(1) 562-764 (3) 739-925 (5) 917-1152	
	3 hp (2.2 kW) *Motor and Drives	Motor horsepower (kW)	3 (2.2)	
		Voltage and phase	380/420v-50hz-3 phase with neutral	
		(Drive kit #) rev/min range	(4) 750-938 (6) 930-1169	
	5 hp (3.7 kW) *Motor and Drives	Motor output — hp (kW)	5 (3.7)	
		Voltage and phase	380/420v-50hz-3 phase with neutral	
		(Drive kit #) rev/min range	(2) 561-776 (4) 739-924 (6) 916-1151	
Indoor Coil	Net face area — sq. ft. (m ²)		10.5 (0.98) total	
	Tube diameter — in. (mm) and number of rows		3/8 (9.5) — 3	3/8 (9.5) — 4
	Fins per inch (m)		14 (551)	
	Drain connection number and size — in. (mm)		(1) 1 (25.4) female pipe thread	
	Expansion device type		Balanced Port Thermostatic Expansion Valve, removeable power head	
Outdoor Coil	Net face area — sq. ft. (m ²)		28.6 (2.66) total	
	Tube diameter — in. (mm) and number of rows		3/8 (9.5) — 2	
	Fins per inch (m)		20 (787)	
	Expansion device type		Balanced Port Thermostatic Expansion Valve, removeable power head	
Outdoor Fans	Diameter — in. (mm) and number of blades		(2) 24 (610) — 3	
	Total Air volume — cfm (L/s)		6665 (3 145)	
	Motor output – horsepower (W)		(2) 1/3 (249)	
	Motor rev/min		895	
	Total motor watts		535	
Filters (furnished)	Type of filter		Disposable, commercial grade, pleated	
	Number and size — in. (mm)		(4) 18 x 24 x 2 (457 x 610 x 51)	
Electrical characteristics		380/420v-50hz-3 phase with neutral		

*Rated test conditions are those included in Air Conditioning and Refrigeration Institute (ARI) Standard 340-86 while operating at rated voltage and air volumes.

Cooling Ratings— 95°F (35°C) outdoor air temperature and 80°F (27°C) db/67°F (19°C) wb entering indoor coil air.

High Temperature Heating Ratings— 47°F (8°C) db/43°F (6°C) wb outdoor air temperature and 70°F (21°C) entering indoor coil air.

Low Temperature Heating Ratings— 17°F (-8°C) db/15°F (-9°C) wb outdoor air temperature and 70°F (21°C) entering indoor coil air.

†Integrated Part Load Value rated at 80°F (27°C) outdoor air temperature.

●Sound rating number rated at test conditions included in Air Conditioning and Refrigeration Institute (ARI) Standard 270-96.

NOTE — Net capacity includes evaporator blower motor heat deduction. Gross capacity does not include evaporator blower motor heat deduction.

OPTIONAL FIELD INSTALLED ACCESSORIES

ALL MODELS

Unit Model Number		LCA/LGA102/120/150 and LHA090/120	
LPG/Propane Conversion Kit (LGA models only)		19K52	
Cold Weather Kit (LGA models only)		65C03	
Down-Flow Roof Mounting Frame (Net Weight)	14 inch (356 mm) height	LARMF10/15-14 – 126 lbs. (57 kg)	
	24 inch (610 mm) height	LARMF10/15-24 – 174 lbs. (79 kg)	
Economizer (Outdoor Air Hood Required – Order Separately)	Model Number — (Net Weight)	LAREMD10/15 – 47 lbs. (21 kg)	
Outdoor Air Hood — (Net Weight)		LAOAH10/15 – 11 lbs. (5 kg)	
Outdoor Enthalpy Control		16K96	
Differential Enthalpy Control		16K97	
Gravity Exhaust Dampers (Required With Economizer) (Net Weight)	Down-Flow	LAGED10/15 – 8 lbs. (4 kg)	
	*Horizontal	LAGEDH10/15 – 8 lbs. (4 kg)	
Horizontal Conversion Kit		56K53	
Power Exhaust Fan (Down-Flow Only) (Available With Economizer Only, Down-flow Gravity Exhaust Dampers Required)	Model Number (Net Weight)	LAPEF10/15 – 28 lbs. (13 kg)	
	Diameter — in. (mm) and number of Blades	(1) 20 (508) – 5	
	Total air volume — cfm (L/s)	4200 (1980) @ 0 in. w.g. (0 Pa)	
	Motor Horsepower (W)	(1) 1/3 (249)	
	Total Watts input	300	
Ceiling Supply and Return Air Diffusers (Net Weight)	Step-Down	RTD11-135 (090, 102 and 120 models) 205 lbs. (93 kg)	RTD11-185 (150 models) 392 lbs. (178 kg)
	Flush	FD11-135 (090, 102 and 120 models) 174 lbs. (79 kg)	FD11-185 (150 models) 289 lbs. (131 kg)
	Transition	LASRT10/12 (090, 102 and 120 models) 32 lbs. (15 kg)	LASRT15 (150 models) 36 lbs. (16 kg)
Outdoor Air Damper (Manual Operation) — (Net Weight) (Outdoor Air Hood Required – Order Separately)		LAOAD10/15 – 26 lbs. (12 kg)	
Outdoor Air Damper (Automatic Operation) — (Net Weight) (Outdoor Air Hood Required – Order Separately)		LAOADM10/15 – 31 lbs. (14 kg)	
Outdoor Air Hood — (Net Weight)		LAOAH10/15 – 11 lbs. (5 kg)	
Indoor Air Quality (CO ₂) Sensor		18K51	

*Field installs in return air duct. Two dampers furnished per order number

WEIGHT DATA

ALL MODELS

Model Number	Description	Weight	
		lbs.	kg
Net Weights			
LCA102S	Net weight (Base unit)	1120	508
LCA120S	Net weight (Base unit)	1130	513
LCA150S	Net weight (Base unit)	1170	531
LGA102S	Net weight (Base unit with low fire heat exchanger)	1200	544
LGA120S	Net weight (Base unit with low fire heat exchanger)	1210	549
LGA150S	Net weight (Base unit with low fire heat exchanger)	1250	567
LHA090H	Net weight (Base unit)	1180	535
LHA120H	Net weight (Base unit)	1230	558
Shipping Weights (Add Factory Installed Options Weights To Base Unit Weights For Total Shipping Weight)			
LCA102S	Base unit	1205	547
LCA120S	Base unit	1215	551
LCA150S	Base unit	1255	569
LHA090H	Base unit	1265	574
LHA120H	Base unit	1315	596
LCA/LHA Models Only	Electric Heat (add to Base unit)	See Electric Heat Rating Tables	
LGA102S	Base unit with low fire heat exchanger	1285	583
LGA120S	Base unit with low fire heat exchanger	1295	587
LGA150S	Base unit with low fire heat exchanger	1335	606
LGA Models Only	High Fire Heat Exchanger (add to Base unit)	40	18
All Models	Economizer (add to Base unit)	66	30
	Outdoor Air Damper (add to Base unit)	40	18
	Power Exhaust (add to Base unit)	28	13
	LTL Packaging (less than truck load) (add to Base unit)	105	48

OPTIONAL ELECTRIC HEAT ACCESSORIES

LCA

UNIT FUSE BLOCKS WITH ELECTRIC HEAT

Unit Model Number		LCA102S	LCA102H	LCA120S	LCA120H	LCA150S	LHA090H	LHA120H	
Electric Heat	Model Number	EHA (see Electric Heat Data tables for additional information)							
	kW Input Range	5-12.5-25-40-50							
Unit Fuse Block (3 phase)	Without Power Exhaust Fans	2 hp (1.5 kW)	25K08	25K08	25K08	25K09	25K08	56K52	25K09
		3 hp (2.2 kW)	25K08	25K08	25K09	25K09	25K08	56K52	25K09
		5 hp (3.7 kW)	25K09	25K08	25K09	25K09	25K09	25K08	25K09
	With Power Exhaust Fans	2 hp (1.5 kW)	25K08	25K08	25K09	25K09	25K08	56K52	25K09
		3 hp (2.2 kW)	25K08	25K08	25K09	25K09	25K09	25K08	25K09
		5 hp (3.7 kW)	25K09	25K09	25K09	25K10	25K09	25K08	25K10

LTB2 ELECTRIC HEAT TERMINAL BLOCK

LTB2-175 (30K75)

(Required For Units Without Disconnect/Circuit Breaker But With Single Point Power Source)

LCA102S	LCA102H	LCA120S	LCA120H	LCA150S	LHA090H	LHA120H
30K75	30K75	30K75	30K75	30K75	30K75	30K75

NOTE — Terminal Block is factory installed in units with factory installed electric heat with single point power source.

ELECTRICAL DATA — 102, 120 AND 150 SIZES

LCA/LGA

Model Number		LCA/LGA102			LCA/LGA120			LCA/LGA150			
Line voltage data — 50 Hz — 3 phase with neutral		380/420v			380/420v			380/420v			
Compressors (2)	Rated load amps each (total)	5.66 (11.3)			6.9 (13.8)			9.4 (18.8)			
	Locked rotor amps each (total)	52.5 (105)			55 (110)			72 (144)			
Condenser Fan Motors (2)	Full load amps (total)	2.6			2.6			2.6			
	Locked rotor amps (total)	4.8			4.8			4.8			
Evaporator Blower Motor	Motor Output	hp	2	3	5	2	3	5	2	3	5
		kW	1.5	2.2	3.7	1.5	2.2	3.7	1.5	2.2	3.7
	Full load amps	3.0	4.66	7.36	3.0	4.66	7.36	3.0	4.66	7.36	
	Locked rotor amps	22.1	27	41	22.1	27	41	22.1	27	41	
Optional Power Exhaust Fan	(Number) Horsepower (W)	(1) 1/3 (249)			(1) 1/3 (249)			(1) 1/3 (249)			
	Full load amps	1.3			1.3			1.3			
	Locked rotor amps	2.4			2.4			2.4			

Refer to local electrical codes to determine wire, fuse and disconnect size requirements. Use wires suitable for at least 167 °F (75°C). Service Factor = 1.15

ELECTRICAL DATA — 090 AND 120 SIZES

LHA

Model No.		LHA090H			LHA120H			
Line voltage data — 50 Hz — 3 phase with neutral		380/420v			380/420v			
Compressors (2)	Rated load amps each (total)	7.1 (14.20)			10 (20)			
	Locked rotor amps each (total)	46 (92)			58 (116)			
Outdoor Fan Motors (2)	Full load amps (total)	2.6			2.6			
	Locked rotor amps (total)	4.8			4.8			
Indoor Blower Motor	Motor Output	hp	2	3	5	2	3	5
		kW	1.5	2.2	3.7	1.5	2.2	3.7
	Full load amps	3.0	4.66	7.36	3.0	4.66	7.36	
	Locked rotor amps	22.1	27	41	22.1	27	41	
Optional Power Exhaust Fan	(No.) Horsepower (W)	(1) 1/3 (249)			(1) 1/3 (249)			
	Full load amps	1.3			1.3			
	Locked rotor amps	2.4			2.4			

Refer to local electrical codes to determine wire, fuse and disconnect size requirements. Use wires suitable for at least 167 °F (75°C). Service Factor = 1.15

NOVAR ETM-2050 CONTROL SYSTEM

- A — Three phase with neutral (See Electrical Data Table)
- B — RS-485 shielded pair twisted wire
- C — Four wire 24V
- D — Two wire 24V

— Field wiring not furnished —

NOTE — All wiring must conform to local electrical codes.

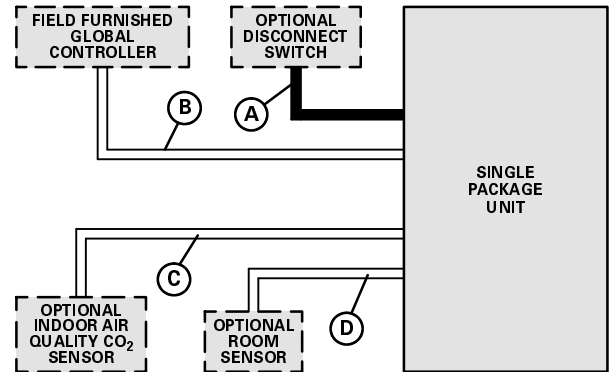

ELECTRO-MECHANICAL, ELECTRONIC OR HONEYWELL T7300 THERMOSTAT CONTROL SYSTEM

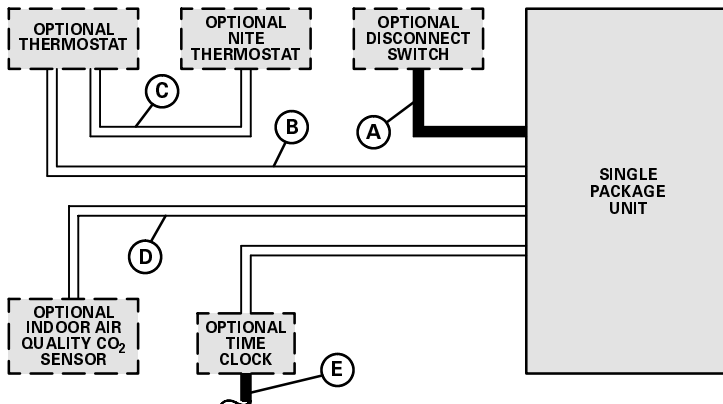

- A — Three phase with neutral (See Electrical Data Table)
- B — Six wire 24V (Electro-Mechanical)
Seven wire 24V (Electronic)
Nine wire 24V (Honeywell T7300)
Ten wire 24V (Honeywell T7300 with Service LED)
- C — Two wire 24V (Electro-Mechanical Only)
- D — Four wire 24V (All Systems)
- E — Two wire power

— Field wiring not furnished —

NOTE — All wiring must conform to local electrical codes.

102 SIZE

kW Size	Electric Heat Model Number (see footnote) Net Weight	Number of Elements	Volts Input	Total Heating Capacity - 50hz			Total Unit & Electric Heat (With Power Exhaust) Minimum Circuit Ampacity (A)		
				kW	kcal	Btuh	2 hp (1.5 kW)	3 hp (2.2 kW)	5 hp (3.7 kW)
5	EHA102-7.5 (99J02) 31 lbs. (14 kg)	1	380	4.7	4040	16 000	24	25	28
		1	400	5.2	4480	17 800			
		1	420	5.7	4935	19 600			
12.5	EHA150-15 (99J05) 31 lbs. (14 kg)	1	380	9.4	8090	32 100	25	27	30
		1	400	10.4	8970	35 600			
		1	420	11.5	9880	39 200			
25	EHA150-30 (99J08) 38 lbs. (17 kg)	*2	380	18.8	16 200	64 200	44	46	50
		*2	400	20.8	17 900	71 100			
		*2	420	23.0	19 800	78 400			
40	EHA150-45 (99J11) 42 lbs. (19 kg)	*2	380	28.2	24 300	96 300	64	66	69
		*2	400	31.2	26 900	106 700			
		*2	420	34.4	26 600	117 600			

*May be used with two stage control.

NOTE — Fuse block must be ordered extra. Factory installed heaters will have the fuse block factory installed. Fuse block must be installed in unit with field installed heaters. Also requires LTB2 Terminal Block.

120 SIZE

kW Size	Electric Heat Model Number (see footnote) Net Weight	Number of Elements	Volts Input	Total Heating Capacity - 50hz			Total Unit & Electric Heat (With Power Exhaust) Minimum Circuit Ampacity (A)		
				kW	kcal	Btuh	2 hp (1.5 kW)	3 hp (2.2 kW)	5 hp (3.7 kW)
12.5	EHA150-15 (99J05) 31 lbs. (14 kg)	1	380	9.4	8090	32 100	26	27	30
		1	400	10.4	8970	35 600			
		1	420	11.5	9880	39 200			
25	EHA150-30 (99J08) 38 lbs. (17 kg)	*2	380	18.8	16 200	64 200	44	46	50
		*2	400	20.8	17 900	71 100			
		*2	420	23.0	19 800	78 400			
40	EHA150-45 (99J11) 42 lbs. (19 kg)	*2	380	28.2	24 300	96 300	64	66	69
		*2	400	31.2	26 900	106 700			
		*2	420	34.4	26 600	117 600			
50	EHA150-60 (99J14) 49 lbs. (22 kg)	*2	380	37.6	32 400	128 400	68	70	73
		*2	400	41.6	35 800	142 200			
		*2	420	45.9	39 500	156 800			

*May be used with two stage control.

NOTE — Fuse block must be ordered extra. Factory installed heaters will have the fuse block factory installed. Fuse block must be installed in unit with field installed heaters. Also requires LTB2 Terminal Block.

150 SIZE

kW Size	Electric Heat Model Number (see footnote) Net Weight	Number of Elements	Volts Input	Total Heating Capacity - 50hz			Total Unit & Electric Heat (With Power Exhaust) Minimum Circuit Ampacity (A)		
				kW	kcal	Btuh	2 hp (1.5 kW)	3 hp (2.2 kW)	5 hp (3.7 kW)
12.5	EHA150-15 (99J05) 31 lbs. (14 kg)	1	380	9.4	8090	32 100	25	27	30
		1	400	10.4	8970	35 600			
		1	420	11.5	9880	39 200			
25	EHA150-30 (99J08) 38 lbs. (17 kg)	*2	380	18.8	16 200	64 200	44	46	50
		*2	400	20.8	17 900	71 100			
		*2	420	23.0	19 800	78 400			
40	EHA150-45 (99J11) 42 lbs. (19 kg)	*2	380	28.2	24 300	96 300	64	66	69
		*2	400	31.2	26 900	106 700			
		*2	420	34.4	26 600	117 600			
50	EHA150-60 (99J14) 49 lbs. (22 kg)	*2	380	37.6	32 400	128 400	68	70	73
		*2	400	41.6	35 800	142 200			
		*2	420	45.9	39 500	156 800			

*May be used with two stage control.

NOTE — Fuse block must be ordered extra. Factory installed heaters will have the fuse block factory installed. Fuse block must be installed in unit with field installed heaters. Also requires LTB2 Terminal Block.

090 SIZE

kW Size	Electric Heat Model Number (see footnote) Net Weight	Number of Elements	Volts Input	Total Heating Capacity - 50hz			Total Unit & Electric Heat (With Power Exhaust) Minimum Circuit Ampacity (A)		
				kW	kcal	Btuh	2 hp (1.5 kW)	3 hp (2.2 kW)	5 hp (3.7 kW)
5	EHA102-7.5 (99J02) 31 lbs. (14 kg)	1	380	4.7	4040	16 000	30	32	35
		1	400	5.2	4480	17 800			
		1	420	5.7	4935	19 600			
12.5	EHA150-15 (99J05) 31 lbs. (14 kg)	1	380	9.4	8090	32 100	40	42	45
		1	400	10.4	8970	35 600			
		1	420	11.5	9880	39 200			
25	EHA150-30 (99J08) 38 lbs. (17 kg)	*2	380	18.8	16 200	64 200	60	61	64
		*2	400	20.8	17 900	71 100			
		*2	420	23.0	19 800	78 400			
40	EHA150-45 (99J11) 42 lbs. (19 kg)	*2	380	28.2	24 300	96 300	79	81	84
		*2	400	31.2	26 900	106 700			
		*2	420	34.4	26 600	117 600			

*May be used with two stage control.

NOTE — Fuse block must be ordered extra. Factory installed heaters will have the fuse block factory installed. Fuse block must be installed in unit with field installed heaters. Also requires LTB2 Terminal Block.

120 SIZE

kW Size	Electric Heat Model Number (see footnote) Net Weight	Number of Elements	Volts Input	Total Heating Capacity - 50hz			Total Unit & Electric Heat (With Power Exhaust) Minimum Circuit Ampacity (A)		
				kW	kcal	Btuh	2 hp (1.5 kW)	3 hp (2.2 kW)	5 hp (3.7 kW)
12.5	EHA150-15 (99J05) 31 lbs. (14 kg)	1	380	9.4	8090	32 100	46	48	50
		1	400	10.4	8970	35 600			
		1	420	11.5	9880	39 200			
25	EHA150-30 (99J08) 38 lbs. (17 kg)	*2	380	18.8	16 200	64 200	65	67	70
		*2	400	20.8	17 900	71 100			
		*2	420	23.0	19 800	78 400			
40	EHA150-45 (99J11) 42 lbs. (19 kg)	*2	380	28.2	24 300	96 300	85	87	89
		*2	400	31.2	26 900	106 700			
		*2	420	34.4	26 600	117 600			
50	EHA150-60 (99J14) 49 lbs. (22 kg)	*2	380	37.6	32 400	128 400	89	91	93
		*2	400	41.6	35 800	142 200			
		*2	420	45.9	39 500	156 800			

*May be used with two stage control.

NOTE — Fuse block must be ordered extra. Factory installed heaters will have the fuse block factory installed. Fuse block must be installed in unit with field installed heaters. Also requires LTB2 Terminal Block.

RATINGS — 50hz

NOTE — For Temperatures and Capacities not shown in tables, see bulletin — Cooling Unit Rating Table Correction Factor Data in Miscellaneous Engineering Data Section.

LCA/LGA150S — STANDARD EFFICIENCY — ONE COMPRESSOR OPERATING

Entering Wet Bulb Temperature	Total Air Volume		Outdoor Temperature																							
			18°C (65°F)					24°C (75°F)					29°C (85°F)					35°C (95°F)								
			Total Cooling Capacity		Compressor Motor kW	Sensible To Total Ratio (S/T)			Total Cooling Capacity		Compressor Motor kW	Sensible To Total Ratio (S/T)			Total Cooling Capacity		Compressor Motor kW	Sensible To Total Ratio (S/T)			Total Cooling Capacity		Compressor Motor kW	Sensible To Total Ratio (S/T)		
			kW	Btuh		Dry Bulb			kW	Btuh		Dry Bulb			kW	Btuh		Dry Bulb			kW	Btuh		Dry Bulb		
						24°C 75°F	27°C 80°F	29°C 85°F				24°C 75°F	27°C 80°F	29°C 85°F				24°C 75°F	27°C 80°F	29°C 85°F				24°C 75°F	27°C 80°F	29°C 85°F
17.2°C (63°F)	1.80	3800	22.8	77 700	4.15	.66	.81	.95	21.2	72 500	4.58	.67	.83	.97	19.8	67 400	5.01	.68	.85	.99	18.4	62 700	5.45	.69	.87	1.00
	2.10	4400	23.3	79 500	4.18	.69	.86	.99	21.7	74 100	4.62	.70	.88	1.00	20.3	69 100	5.06	.72	.91	1.00	18.8	64 300	5.50	.73	.93	1.00
	2.35	5000	23.7	81 000	4.21	.73	.91	1.00	22.2	75 600	4.65	.74	.93	1.00	20.7	70 600	5.09	.76	.95	1.00	19.3	65 800	5.55	.78	.97	1.00
19.4°C (67°F)	1.80	3800	24.1	82 200	4.23	.53	.64	.77	22.5	76 800	4.67	.52	.65	.79	21.0	71 600	5.12	.52	.65	.81	19.5	66 600	5.57	.52	.66	.83
	2.10	4400	24.5	83 700	4.25	.54	.67	.82	22.9	78 200	4.70	.54	.68	.85	21.4	72 900	5.16	.54	.69	.87	19.9	67 800	5.61	.54	.70	.89
	2.35	5000	24.9	85 000	4.27	.56	.70	.87	23.3	79 400	4.72	.56	.72	.90	21.7	74 000	5.18	.56	.73	.92	20.2	68 900	5.64	.56	.75	.94
21.7°C (71°F)	1.80	3800	25.5	87 100	4.30	.40	.51	.62	23.9	81 600	4.77	.39	.51	.62	22.3	76 200	5.23	.39	.51	.63	20.8	71 100	5.71	.38	.51	.64
	2.10	4400	26.0	88 600	4.32	.41	.53	.65	24.3	83 000	4.79	.40	.53	.66	22.7	77 600	5.27	.39	.53	.67	21.2	72 400	5.74	.38	.53	.68
	2.35	5000	26.3	89 800	4.34	.41	.55	.68	24.6	84 100	4.81	.41	.55	.69	23.0	78 600	5.29	.40	.55	.71	21.5	73 400	5.77	.39	.55	.72

LCA/LGA150S — STANDARD EFFICIENCY — ALL COMPRESSORS OPERATING

Entering Wet Bulb Temperature	Total Air Volume		Outdoor Temperature																							
			27°C (80°F)					35°C (95°F)					43°C (110°F)					52°C (125°F)								
			Total Cooling Capacity		Compressor Motor kW	Sensible To Total Ratio (S/T)			Total Cooling Capacity		Compressor Motor kW	Sensible To Total Ratio (S/T)			Total Cooling Capacity		Compressor Motor kW	Sensible To Total Ratio (S/T)			Total Cooling Capacity		Compressor Motor kW	Sensible To Total Ratio (S/T)		
			kW	Btuh		Dry Bulb			kW	Btuh		Dry Bulb			kW	Btuh		Dry Bulb			kW	Btuh		Dry Bulb		
						24°C 75°F	27°C 80°F	29°C 85°F				24°C 75°F	27°C 80°F	29°C 85°F				24°C 75°F	27°C 80°F	29°C 85°F				24°C 75°F	27°C 80°F	29°C 85°F
17.2°C (63°F)	1.80	3800	39.4	134 400	9.68	.68	.84	.99	36.0	122 900	10.97	.70	.88	1.00	32.8	111 800	12.30	.72	.92	1.00	29.5	100 700	13.62	.75	.96	1.00
	2.10	4400	40.3	137 600	9.76	.71	.90	1.00	36.9	126 000	11.08	.74	.94	1.00	33.7	114 900	12.42	.77	.97	1.00	30.4	103 800	13.79	.81	1.00	1.00
	2.35	5000	41.1	140 400	9.83	.75	.95	1.00	37.7	128 800	11.17	.78	.98	1.00	34.5	117 700	12.55	.82	1.00	1.00	31.3	106 900	13.95	.86	1.00	1.00
19.4°C (67°F)	1.80	3800	41.8	142 500	9.89	.53	.66	.80	38.2	130 400	11.24	.54	.67	.84	34.8	118 800	12.58	.54	.69	.87	31.3	106 800	13.94	.55	.72	.92
	2.10	4400	42.6	145 400	9.95	.55	.69	.86	38.9	132 900	11.32	.56	.71	.90	35.5	121 000	12.68	.56	.74	.94	31.9	108 900	14.04	.58	.78	.98
	2.35	5000	43.2	147 500	10.01	.57	.72	.91	39.6	135 000	11.38	.58	.75	.95	36.0	122 900	12.75	.59	.79	.99	32.4	110 700	14.12	.60	.83	1.00
21.7°C (71°F)	1.80	3800	44.5	151 700	10.11	.40	.52	.63	40.8	139 200	11.52	.39	.52	.65	37.3	127 200	12.92	.39	.53	.67	33.6	114 800	14.31	.38	.54	.69
	2.10	4400	45.3	154 400	10.17	.40	.54	.67	41.5	141 600	11.59	.40	.54	.69	37.9	129 300	13.00	.40	.55	.71	34.2	116 700	14.40	.39	.57	.75
	2.35	5000	45.9	156 500	10.22	.41	.56	.70	42.1	143 500	11.65	.41	.57	.73	38.4	131 000	13.06	.40	.58	.76	34.6	118 200	14.48	.40	.59	.80

RATINGS — 50hz

NOTE — For Temperatures and Capacities not shown in tables, see bulletin — Cooling Unit Rating Table Correction Factor Data in Miscellaneous Engineering Data Section.

LHA090H — COOLING CAPACITY — HIGH EFFICIENCY — ONE COMPRESSOR OPERATING

Entering Wet Bulb Temperature	Total Air Volume		Outdoor Temperature																							
			18°C (65°F)						24°C (75°F)						29°C (85°F)						35°C (95°F)					
			Total Cooling Capacity		Compressor Motor kW	Sensible To Total Ratio (S/T)			Total Cooling Capacity		Compressor Motor kW	Sensible To Total Ratio (S/T)			Total Cooling Capacity		Compressor Motor kW	Sensible To Total Ratio (S/T)			Total Cooling Capacity		Compressor Motor kW	Sensible To Total Ratio (S/T)		
						Dry Bulb						Dry Bulb						Dry Bulb						Dry Bulb		
m ³ /s	cfm	kW	Btuh	kW	Btuh	kW	Btuh	kW	Btuh	kW	Btuh	kW	Btuh	kW	Btuh	kW	Btuh	kW	Btuh	kW	Btuh	kW	Btuh	kW	Btuh	
17.2°C (63°F)	1.15	2400	14.1	48 000	1.85	.72	.87	.99	13.2	45 000	2.09	.72	.88	1.00	12.3	41 900	2.36	.72	.89	1.00	11.3	38 700	2.67	.73	.90	1.00
	1.40	3000	14.6	49 700	1.86	.78	.94	1.00	13.7	46 700	2.10	.78	.96	1.00	12.8	43 600	2.37	.79	.97	1.00	11.8	40 400	2.68	.80	.98	1.00
	1.70	3600	15.0	51 300	1.87	.83	.99	1.00	14.2	48 300	2.11	.84	1.00	1.00	13.3	45 300	2.38	.85	1.00	1.00	12.3	42 100	2.69	.87	1.00	1.00
19.4°C (67°F)	1.15	2400	14.9	50 800	1.87	.57	.70	.83	14.0	47 700	2.11	.56	.70	.84	13.0	44 500	2.38	.56	.70	.85	12.1	41 200	2.68	.55	.70	.86
	1.40	3000	15.3	52 300	1.88	.60	.75	.91	14.4	49 100	2.11	.60	.76	.92	13.4	45 800	2.38	.59	.76	.94	12.5	42 500	2.69	.59	.77	.96
	1.70	3600	15.6	53 400	1.88	.63	.81	.97	14.7	50 100	2.12	.63	.82	.99	13.7	46 800	2.39	.63	.83	1.00	12.7	43 400	2.69	.63	.85	1.00
21.7°C (71°F)	1.15	2400	15.8	54 000	1.88	.44	.56	.67	14.9	50 800	2.12	.42	.55	.68	13.9	47 500	2.39	.41	.54	.68	13.0	44 200	2.70	.39	.53	.68
	1.40	3000	16.3	55 500	1.89	.45	.59	.73	15.3	52 200	2.13	.43	.59	.73	14.3	48 800	2.40	.42	.58	.74	13.3	45 300	2.70	.40	.58	.75
	1.70	3600	16.5	56 400	1.90	.46	.62	.79	15.6	53 100	2.13	.45	.62	.80	14.6	49 700	2.40	.44	.62	.81	13.5	46 100	2.71	.42	.62	.82

LHA090H — COOLING CAPACITY — HIGH EFFICIENCY — ALL COMPRESSORS OPERATING

Entering Wet Bulb Temperature	Total Air Volume		Outdoor Temperature																							
			27°C (80°F)						35°C (95°F)						43°C (110°F)						52°C (125°F)					
			Total Cooling Capacity		Compressor Motor kW	Sensible To Total Ratio (S/T)			Total Cooling Capacity		Compressor Motor kW	Sensible To Total Ratio (S/T)			Total Cooling Capacity		Compressor Motor kW	Sensible To Total Ratio (S/T)			Total Cooling Capacity		Compressor Motor kW	Sensible To Total Ratio (S/T)		
						Dry Bulb						Dry Bulb						Dry Bulb						Dry Bulb		
m ³ /s	cfm	kW	Btuh	kW	Btuh	kW	Btuh	kW	Btuh	kW	Btuh	kW	Btuh	kW	Btuh	kW	Btuh	kW	Btuh	kW	Btuh	kW	Btuh	kW	Btuh	
17.2°C (63°F)	1.15	2400	24.4	83 300	4.38	.73	.88	1.00	22.4	76 500	5.26	.74	.91	1.00	20.3	69 400	6.31	.75	.94	1.00	18.1	61 800	7.59	.77	.98	1.00
	1.40	3000	25.4	86 500	4.40	.78	.96	1.00	23.4	79 700	5.28	.80	.99	1.00	21.3	72 600	6.34	.83	1.00	1.00	19.1	65 300	7.63	.86	1.00	1.00
	1.70	3600	26.2	89 500	4.42	.85	1.00	1.00	24.3	82 900	5.30	.87	1.00	1.00	22.2	75 800	6.36	.90	1.00	1.00	20.0	68 300	7.64	.94	1.00	1.00
19.4°C (67°F)	1.15	2400	25.9	88 500	4.41	.56	.70	.84	23.9	81 400	5.29	.56	.71	.87	21.7	73 900	6.35	.56	.73	.90	19.3	65 800	7.63	.56	.75	.94
	1.40	3000	26.7	91 200	4.42	.60	.76	.93	24.6	83 900	5.30	.60	.78	.96	22.3	76 200	6.37	.61	.80	.99	19.9	67 800	7.65	.61	.83	1.00
	1.70	3600	27.3	93 100	4.44	.63	.82	1.00	25.1	85 700	5.31	.64	.85	1.00	22.8	77 900	6.37	.65	.88	1.00	20.4	69 500	7.65	.66	.92	1.00
21.7°C (71°F)	1.15	2400	27.7	94 400	4.44	.42	.55	.68	25.5	87 100	5.32	.41	.55	.69	23.2	79 200	6.38	.39	.55	.70	20.7	70 800	7.66	.38	.55	.72
	1.40	3000	28.4	97 000	4.46	.43	.59	.74	26.2	89 300	5.33	.42	.59	.75	23.8	81 300	6.39	.41	.60	.78	21.3	72 600	7.68	.40	.61	.81
	1.70	3600	28.9	98 700	4.46	.45	.62	.80	26.6	90 900	5.35	.44	.63	.82	24.2	82 700	6.40	.43	.64	.85	21.7	73 900	7.68	.42	.66	.89

LHA090H — HEATING CAPACITY — HIGH EFFICIENCY — ALL COMPRESSORS OPERATING

Indoor Coil Air Volume 70°F db (21°C db)	* Outdoor Temperature																			
	65°F (18°C)				45°F (7°C)				25°F (-4°C)				5°F (-15°C)				-15°F (-28°C)			
	Total Heating Capacity		Compressor Motor kW	Total Heating Capacity		Compressor Motor kW	Total Heating Capacity		Compressor Motor kW	Total Heating Capacity		Compressor Motor kW	Total Heating Capacity		Compressor Motor kW	Total Heating Capacity		Compressor Motor kW		
m ³ /s	cfm	kW		Btuh	kW		Btuh	kW		Btuh	kW		Btuh	kW		Btuh	kW		Btuh	kW
1.15	2400	29.5	100,600	6.4	22.4	76,400	6.1	15.0	51,200	5.7	9.8	33,500	5.5	5.0	16,900	4.1				
1.40	3000	29.9	102,000	5.9	22.8	77,800	5.6	15.4	52,600	5.2	10.2	34,900	5.0	5.4	18,300	3.6				
1.70	3600	30.3	103,400	5.6	23.2	79,200	5.3	15.8	54,000	5.0	10.6	36,300	4.7	5.8	19,700	3.3				

NOTE — Heating capacities include the effect of defrost cycles in the temperature range where they occur.

RATINGS — 50hz

NOTE — For Temperatures and Capacities not shown in tables, see bulletin — Cooling Unit Rating Table Correction Factor Data in Miscellaneous Engineering Data Section.

LHA120H — COOLING CAPACITY — HIGH EFFICIENCY — ONE COMPRESSOR OPERATING

Entering Wet Bulb Temperature	Total Air Volume		Outdoor Temperature																							
			18°C (65°F)						24°C (75°F)						29°C (85°F)				35°C (95°F)							
			Total Cooling Capacity		Compressor Motor kW	Sensible To Total Ratio (S/T)			Total Cooling Capacity		Compressor Motor kW	Sensible To Total Ratio (S/T)			Total Cooling Capacity		Compressor Motor kW	Sensible To Total Ratio (S/T)			Total Cooling Capacity		Compressor Motor kW	Sensible To Total Ratio (S/T)		
			kW	Btuh		Dry Bulb			kW	Btuh		Dry Bulb			kW	Btuh		Dry Bulb			kW	Btuh		Dry Bulb		
					24°C 75°F	27°C 80°F	29°C 85°F	24°C 75°F			27°C 80°F	29°C 85°F	24°C 75°F	27°C 80°F			29°C 85°F	24°C 75°F	27°C 80°F	29°C 85°F			24°C 75°F	27°C 80°F	29°C 85°F	
17.2°C (63°F)	1.50	3200	18.4	62 800	2.75	.71	.86	1.00	17.4	59 300	3.09	.71	.88	1.00	16.4	55 800	3.48	.72	.89	1.00	15.3	52 100	3.93	.72	.91	1.00
	1.90	4000	19.1	65 200	2.77	.77	.95	1.00	18.1	61 700	3.11	.78	.97	1.00	17.0	58 100	3.50	.79	.98	1.00	15.9	54 400	3.96	.80	1.00	1.00
	2.25	4800	19.8	67 400	2.79	.83	1.00	1.00	18.8	64 000	3.13	.85	1.00	1.00	17.7	60 400	3.53	.86	1.00	1.00	16.6	56 700	3.99	.88	1.00	1.00
19.4°C (67°F)	1.50	3200	19.5	66 500	2.78	.56	.69	.83	18.4	62 800	3.12	.56	.69	.84	17.3	59 100	3.51	.55	.70	.85	16.2	55 200	3.97	.55	.70	.87
	1.90	4000	20.0	68 400	2.80	.59	.74	.92	19.0	64 700	3.14	.59	.75	.93	17.8	60 800	3.53	.59	.76	.95	16.7	56 900	3.99	.59	.77	.97
	2.25	4800	20.5	69 800	2.81	.63	.81	.99	19.3	66 000	3.15	.63	.82	1.00	18.2	62 100	3.55	.63	.84	1.00	17.0	58 100	4.00	.63	.86	1.00
21.7°C (71°F)	1.50	3200	20.7	70 600	2.82	.42	.54	.66	19.6	66 900	3.16	.41	.54	.67	18.5	63 000	3.56	.40	.54	.67	17.3	59 000	4.01	.39	.53	.68
	1.90	4000	21.2	72 400	2.84	.44	.58	.72	20.1	68 600	3.18	.43	.58	.73	18.9	64 600	3.57	.42	.58	.74	17.7	60 500	4.03	.41	.58	.75
	2.25	4800	21.6	73 700	2.85	.45	.62	.79	20.5	69 800	3.19	.44	.62	.80	19.3	65 700	3.59	.43	.62	.81	18.1	61 600	4.05	.42	.63	.83

LHA120H — COOLING CAPACITY — HIGH EFFICIENCY — ALL COMPRESSORS OPERATING

Entering Wet Bulb Temperature	Total Air Volume		Outdoor Temperature																							
			27°C (80°F)						35°C (95°F)						43°C (110°F)				52°C (125°F)							
			Total Cooling Capacity		Compressor Motor kW	Sensible To Total Ratio (S/T)			Total Cooling Capacity		Compressor Motor kW	Sensible To Total Ratio (S/T)			Total Cooling Capacity		Compressor Motor kW	Sensible To Total Ratio (S/T)			Total Cooling Capacity		Compressor Motor kW	Sensible To Total Ratio (S/T)		
			kW	Btuh		Dry Bulb			kW	Btuh		Dry Bulb			kW	Btuh		Dry Bulb			kW	Btuh		Dry Bulb		
					24°C 75°F	27°C 80°F	29°C 85°F	24°C 75°F			27°C 80°F	29°C 85°F	24°C 75°F	27°C 80°F			29°C 85°F	24°C 75°F	27°C 80°F	29°C 85°F			24°C 75°F	27°C 80°F	29°C 85°F	
17.2°C (63°F)	1.50	3200	32.6	111 400	6.48	.72	.88	1.00	30.2	103 000	7.78	.73	.91	1.00	27.6	94 200	9.38	.75	.95	1.00	24.9	84 900	11.28	.77	.99	1.00
	1.90	4000	33.9	115 800	6.52	.78	.97	1.00	31.5	107 400	7.84	.80	1.00	1.00	28.9	98 700	9.44	.83	1.00	1.00	26.3	89 600	11.36	.87	1.00	1.00
	2.25	4800	35.2	120 000	6.57	.85	1.00	1.00	32.8	111 800	7.89	.88	1.00	1.00	30.2	103 000	9.50	.92	1.00	1.00	27.4	93 500	11.42	.96	1.00	1.00
19.4°C (67°F)	1.50	3200	34.6	118 000	6.55	.56	.70	.84	32.0	109 100	7.86	.56	.71	.87	29.2	99 800	9.46	.56	.73	.91	26.3	89 700	11.36	.57	.75	.95
	1.90	4000	35.6	121 500	6.59	.59	.76	.94	32.9	112 400	7.90	.60	.78	.97	30.1	102 700	9.49	.61	.80	1.00	27.1	92 400	11.40	.62	.85	1.00
	2.25	4800	36.4	124 100	6.61	.63	.83	1.00	33.6	114 800	7.93	.64	.86	1.00	30.8	105 000	9.53	.66	.89	1.00	27.8	94 700	11.44	.68	.94	1.00
21.7°C (71°F)	1.50	3200	36.8	125 600	6.63	.41	.54	.67	34.1	116 400	7.94	.40	.55	.69	31.2	106 600	9.55	.40	.55	.70	28.2	96 100	11.46	.39	.56	.73
	1.90	4000	37.8	128 900	6.67	.43	.58	.74	35.0	119 400	7.98	.42	.59	.75	32.0	109 200	9.59	.42	.60	.78	28.8	98 400	11.51	.41	.62	.82
	2.25	4800	38.5	131 200	6.69	.44	.62	.80	35.6	121 500	8.01	.44	.63	.83	32.6	111 100	9.62	.44	.65	.87	29.3	100 000	11.53	.43	.67	.91

LHA120H — HEATING CAPACITY — HIGH EFFICIENCY — ALL COMPRESSORS OPERATING

Indoor Coil Air Volume 70°F db (21°C db)	*Outdoor Temperature																			
	65°F (18°C)				45°F (7°C)				25°F (-4°C)				5°F (-15°C)				-15°F (-28°C)			
	Total Heating Capacity		Compressor Motor kW	Total Heating Capacity		Compressor Motor kW	Total Heating Capacity		Compressor Motor kW	Total Heating Capacity		Compressor Motor kW	Total Heating Capacity		Compressor Motor kW	Total Heating Capacity		Compressor Motor kW		
	kW	Btuh		kW	Btuh		kW	Btuh		kW	Btuh		kW	Btuh		kW	Btuh			
1.50	3200	38.6	131,800	8.4	29.7	101,400	7.8	20.5	69,800	7.3	14.0	47,900	6.6	7.1	24,100	5.0				
1.90	4000	39.0	133,200	7.7	30.1	102,800	7.1	20.9	71,200	6.6	14.4	49,300	5.9	7.5	25,500	4.3				
2.25	4800	40.0	136,400	7.3	31.1	106,000	6.8	21.8	74,400	6.2	15.4	52,500	5.5	8.4	28,700	3.9				

NOTE — Heating capacities include the effect of defrost cycles in the temperature range where they occur.

BLOWER DATA — BASE UNIT

NOTES — **BLOWER PERFORMANCE TABLE INCLUDES INTERNAL RESISTANCE FOR LCA102 BASE UNIT ONLY.**

All data is measured with dry indoor coil and air filters in place.

FOR OTHER UNITS, OR BASE UNIT WITH OPTIONS/ACCESSORIES:

TOTAL STATIC PRESSURE = TOTAL ADDED INTERNAL STATIC PRESSURE + TOTAL ADDED EXTERNAL STATIC PRESSURE

TO DETERMINE **TOTAL ADDED INTERNAL STATIC PRESSURE:** For design air volume, determine total air resistance for 1) wet indoor coil of selected unit, plus 2) all selected factory installed options (heat section, economizer, etc.) and field installed accessories (horizontal roof frame, diffuser, etc.). See page 23 for wet coil and option/accessory air resistance data.

NOTE — BOLD INDICATES FIELD FURNISHED DRIVE.

[Unshaded area denotes 2 hp (1.5 kW) blower motor.]

[Light shaded area denotes 3 hp (2.2 kW) blower motor.]

[Dark shaded area denotes 5 hp (3.7 kW) blower motor.]

LCA102 requires a minimum of 3000 cfm (1.40 m³/s) with electric heat.

LCA120 & LCA150 requires a minimum of 4000 cfm (1.90 m³/s) with electric heat.

Air Volume cfm (m ³ /s)	Total Static Pressure - in. w.g. (Pa)																					
	.20 (50)		.40 (100)		.60 (150)		.80 (200)		1.00 (250)		1.20 (300)		1.40 (350)		1.60 (400)		1.80 (450)		2.00 (495)		2.20 (545)	
	Rev/ Min	BHP (kW)	Rev/ Min	BHP (kW)	Rev/ Min	BHP (kW)	Rev/ Min	BHP (kW)	Rev/ Min	BHP (kW)	Rev/ Min	BHP (kW)	Rev/ Min	BHP (kW)	Rev/ Min	BHP (kW)	Rev/ Min	BHP (kW)	Rev/ Min	BHP (kW)	Rev/ Min	BHP (kW)
2250 (1.05)	455	0.30 (0.22)	555	0.45 (0.34)	640	0.60 (0.45)	720	0.80 (0.60)	790	1.00 (0.75)	855	1.20 (0.90)	915	1.40 (1.04)	975	1.60 (1.19)	1030	1.85 (1.38)	1080	2.05 (1.53)	1130	2.30 (1.72)
2500 (1.20)	475	0.40 (0.30)	575	0.55 (0.41)	660	0.70 (0.52)	735	0.90 (0.67)	805	1.10 (0.82)	870	1.30 (0.97)	930	1.55 (1.16)	985	1.75 (1.31)	1040	2.00 (1.49)	1090	2.25 (1.68)	1140	2.50 (1.87)
2750 (1.30)	495	0.45 (0.34)	595	0.65 (0.48)	675	0.85 (0.63)	750	1.05 (0.78)	820	1.25 (0.93)	885	1.45 (1.08)	940	1.70 (1.27)	995	1.90 (1.42)	1050	2.20 (1.64)	1100	2.45 (1.83)	1145	2.65 (1.98)
3000 (1.40)	525	0.55 (0.41)	615	0.75 (0.56)	695	0.95 (0.71)	770	1.20 (0.90)	835	1.40 (1.04)	895	1.60 (1.19)	955	1.85 (1.38)	1010	2.10 (1.57)	1060	2.35 (1.75)	1110	2.65 (1.98)	1160	2.90 (2.16)
3250 (1.55)	550	0.65 (0.48)	640	0.90 (0.67)	715	1.10 (0.82)	790	1.35 (1.01)	855	1.60 (1.19)	915	1.80 (1.34)	970	2.05 (1.53)	1025	2.35 (1.75)	1075	2.60 (1.94)	1125	2.85 (2.13)	-----	-----
3500 (1.65)	580	0.80 (0.60)	665	1.05 (0.78)	740	1.25 (0.93)	810	1.50 (1.12)	870	1.75 (1.31)	930	2.00 (1.49)	985	2.25 (1.68)	1040	2.55 (1.90)	1090	2.85 (2.13)	1135	3.10 (2.31)	-----	-----
3750 (1.75)	605	0.95 (0.71)	690	1.20 (0.90)	760	1.45 (1.08)	830	1.70 (1.27)	890	1.95 (1.45)	950	2.25 (1.68)	1005	2.50 (1.87)	1055	2.80 (2.09)	1105	3.10 (2.31)	1150	3.35 (2.50)	-----	-----
4000 (1.90)	635	1.10 (0.82)	715	1.40 (1.04)	785	1.65 (1.23)	850	1.90 (1.42)	910	2.20 (1.64)	965	2.45 (1.83)	1020	2.75 (2.05)	1070	3.05 (2.28)	1120	3.35 (2.50)	-----	-----	-----	-----
4250 (2.00)	665	1.30 (0.97)	740	1.60 (1.19)	810	1.85 (1.38)	870	2.15 (1.60)	930	2.45 (1.83)	985	2.75 (2.05)	1040	3.05 (2.28)	1090	3.35 (2.50)	1135	3.65 (2.72)	-----	-----	-----	-----
4500 (2.15)	695	1.50 (1.12)	770	1.80 (1.34)	835	2.10 (1.57)	895	2.40 (1.79)	955	2.70 (2.01)	1005	3.00 (2.24)	1060	3.35 (2.50)	1105	3.65 (2.72)	-----	-----	-----	-----	-----	-----
4750 (2.25)	725	1.75 (1.31)	795	2.05 (1.53)	860	2.40 (1.79)	920	2.70 (2.01)	975	3.00 (2.24)	1030	3.35 (2.50)	1080	3.65 (2.72)	1125	3.95 (2.95)	-----	-----	-----	-----	-----	-----
5000 (2.35)	760	2.05 (1.53)	825	2.35 (1.75)	885	2.65 (1.98)	945	3.00 (2.24)	1000	3.35 (2.50)	1050	3.65 (2.72)	1100	4.00 (2.98)	1145	4.35 (3.25)	-----	-----	-----	-----	-----	-----
5250 (2.50)	790	2.30 (1.72)	855	2.65 (1.98)	910	2.95 (2.20)	970	3.35 (2.50)	1020	3.65 (2.72)	1070	4.00 (2.98)	1120	4.35 (3.25)	-----	-----	-----	-----	-----	-----	-----	-----
5500 (2.60)	820	2.60 (1.94)	880	2.95 (2.20)	940	3.30 (2.46)	995	3.70 (2.76)	1045	4.05 (3.02)	1095	4.40 (3.28)	1145	4.80 (3.58)	-----	-----	-----	-----	-----	-----	-----	-----
5750 (2.70)	850	2.95 (2.20)	910	3.30 (2.46)	965	3.70 (2.76)	1020	4.05 (3.02)	1070	4.45 (3.32)	1120	4.80 (3.58)	1165	5.20 (3.88)	-----	-----	-----	-----	-----	-----	-----	-----
6000 (2.85)	885	3.35 (2.50)	940	3.70 (2.76)	995	4.10 (3.06)	1045	4.45 (3.32)	1095	4.85 (3.62)	1145	5.25 (3.92)	-----	-----	-----	-----	-----	-----	-----	-----	-----	-----

FACTORY INSTALLED DRIVE KIT SPECIFICATIONS

Motor Outputs		Rev/Min Range					
hp	kW	Drive 1	Drive 2	Drive 3	Drive 4	Drive 5	Drive 6
2	1.5	562 - 764	-----	739 - 925	-----	917 - 1152	-----
3	2.2	-----	-----	-----	750 - 938	-----	930 - 1169
5	3.7	-----	561 - 776	-----	739 - 924	-----	916 - 1151

**FACTORY INSTALLED OPTIONS/FIELD INSTALLED ACCESSORY
AIR RESISTANCE**

Air Volume		Total Resistance — inches water gauge (Pa)					
		Wet Indoor Coil		Gas Heat Exchanger (LGA Models)		Electric Heat (LCA/LHA Models)	Economizer
cfm	m ³ /s	090H, 102S, 102H, 120S, 150S	120H	Low Fire	High Fire		
2250	1.05	.06 (15)	.10 (25)	.05 (12)	.09 (22)	.01 (2)	.035 (9)
2500	1.20	.08 (20)	.12 (30)	.05 (12)	.11 (27)	.01 (2)	.04 (10)
2750	1.30	.09 (22)	.14 (35)	.06 (15)	.13 (32)	.01 (2)	.045 (11)
3000	1.40	.10 (25)	.16 (40)	.07 (17)	.16 (40)	.02 (5)	.05 (12)
3250	1.55	.11 (27)	.19 (47)	.08 (20)	.19 (47)	.02 (5)	.06 (15)
3500	1.65	.13 (32)	.21 (52)	.09 (22)	.22 (55)	.03 (7)	.07 (17)
3750	1.75	.14 (35)	.23 (57)	.10 (25)	.26 (65)	.03 (7)	.075 (19)
4000	1.90	.16 (40)	.26 (65)	.11 (27)	.30 (75)	.04 (10)	.08 (20)
4250	2.00	.17 (42)	.28 (70)	.12 (30)	.34 (85)	.04 (10)	.09 (22)
4500	2.15	.18 (45)	.31 (77)	.13 (32)	.38 (94)	.05 (12)	.10 (25)
4750	2.25	.20 (50)	.33 (82)	.14 (35)	.42 (104)	.05 (12)	.11 (27)
5000	2.35	.22 (55)	.36 (90)	.16 (40)	.47 (117)	.06 (15)	.12 (30)
5250	2.50	.24 (60)	.39 (97)	.18 (45)	.52 (129)	.06 (15)	.13 (32)
5500	2.60	.26 (65)	.42 (104)	.20 (50)	.57 (142)	.07 (17)	.14 (35)
5750	2.70	.28 (70)	.45 (112)	.22 (55)	.62 (154)	.07 (17)	.15 (37)
6000	2.85	.30 (75)	.48 (119)	.24 (60)	.68 (169)	.08 (20)	.16 (40)

CEILING DIFFUSER AIR RESISTANCE

Unit Size	Air Volume		Total Resistance — inches water gauge (Pa)			
			RTD11 Step-Down Diffuser			FD11 Flush Diffuser
	cfm	m ³ /s	2 Ends Open	1 Side 2 Ends Open	All Ends and Sides Open	
090, 102 and 120 Models	3600	1.70	.36 (90)	.28 (70)	.23 (57)	.15 (37)
	3800	1.80	.40 (99)	.32 (80)	.26 (65)	.18 (45)
	4000	1.90	.44 (109)	.36 (90)	.29 (72)	.21 (52)
	4200	2.00	.49 (122)	.40 (99)	.33 (82)	.24 (60)
	4400	2.10	.54 (134)	.44 (109)	.37 (92)	.27 (67)
	4600	2.15	.60 (149)	.49 (122)	.42 (104)	.31 (77)
	4800	2.25	.65 (162)	.53 (132)	.46 (114)	.35 (87)
	5000	2.35	.69 (172)	.58 (144)	.50 (124)	.39 (97)
	5200	2.45	.75 (186)	.62 (154)	.54 (134)	.43 (107)
150 Models	4200	2.0	.22 (55)	.19 (47)	.16 (40)	.10 (25)
	4400	2.10	.28 (70)	.24 (60)	.20 (50)	.12 (30)
	4600	2.15	.34 (85)	.29 (72)	.24 (60)	.15 (37)
	4800	2.25	.40 (99)	.34 (85)	.29 (72)	.19 (47)
	5000	2.35	.46 (114)	.39 (97)	.34 (85)	.23 (57)
	5200	2.50	.52 (129)	.44 (109)	.39 (97)	.27 (67)
	5400	2.60	.58 (144)	.49 (122)	.43 (107)	.31 (77)
	5600	2.65	.64 (159)	.54 (134)	.47 (117)	.35 (87)
5800	2.75	.70 (174)	.59 (147)	.51 (127)	.39 (97)	

POWER EXHAUST FANS PERFORMANCE

Return Air System Static Pressure		Air Volume Exhausted	
in. w.g.	Pa	cfm	m ³ /s
0	0	3500	1.65
0.05	12	3310	1.55
0.10	25	3125	1.50
0.15	37	2935	1.40
0.20	50	2750	1.30
0.25	62	2565	1.20
0.30	75	2385	1.10
0.35	87	2200	1.05

CEILING DIFFUSER AIR THROW DATA

Model Number	Air Volume		*Effective Throw Range			
			RTD11 Step-Down		FD11 Flush	
	cfm	m ³ /s	ft.	m	ft.	m
090, 102 and 120 Models	4400	2.10	34 – 42	10 – 13	32 – 40	10 – 12
	4950	2.35	38 – 47	12 – 14	36 – 45	11 – 14
	5500	2.60	43 – 52	13 – 16	40 – 50	12 – 15
150 Models	4200	2.00	39 – 46	12 – 14	40 – 48	12 – 15
	5000	2.35	41 – 50	12 – 15	43 – 52	13 – 16
	5800	2.75	43 – 52	13 – 16	45 – 54	14 – 16

*Throw is the horizontal or vertical distance an airstream travels on leaving the outlet or diffuser before the maximum velocity is reduced to 50 ft. (15 m) per minute. Four sides open.

Prepared for the guidance of architects, consulting engineers and mechanical contractors.

General — Furnish and install a single package air to air direct expansion mechanical cooling system, complete with automatic controls. The single package unit shall be a standard product of a firm regularly engaged in the manufacture of heating-cooling equipment.

The installed weight shall not be more than lbs. (kg). Entire unit shall have a width of not more than inches (mm), a depth of not more than inches (mm) and an overall height of not more than inches (mm). The equipment shall be shipped completely factory assembled, precharged, piped and wired internally ready for field connections. In addition, manufacturer shall test operate system at the factory before shipment.

Air Distribution — Equipment shall be capable of bottom (down-flo) or side (horizontal) handling of conditioned air. Horizontal air shall require optional horizontal conversion kit. All air distribution ducts shall be fiberglass or ga. galvanized steel insulated with inch (mm) thick lb./ft.³ (kg/m³) density fiberglass or equivalent.

Cooling System — The total certified cooling capacity shall not be less than Btuh (kW) with an evaporator air volume of cfm (m³/s), an entering wet bulb air temperature of °F (°C), an entering dry bulb air temperature of °F (°C) and a condenser entering temperature of °F (°C). The compressor power input shall not exceed kW at these conditions.

The coils shall be non-ferrous construction with aluminum fins mechanically bonded to durable copper tubes. Coils shall be pressure leak tested. Coil face area shall be not less than sq. ft. (m²) (evaporator) and sq. ft. (m²) (condenser). Condenser coils shall be slab coil construction.

Multiple compressors shall be resiliently mounted, have overload protection and crankcase heaters. The refrigeration system shall have discharge suction and liquid line gauge ports, high pressure switches, low pressure switches, driers, freestat and full refrigerant charge. Optional service valves shall be available. All models shall have low ambient operation down to 15° F (-9.4° C).

Cabinet — Shall be galvanized steel with a powdered enamel paint finish electrostatically bonded to the metal. Cabinet panels where conditioned air is handled shall be fully insulated to prevent sweating and minimize sound. Openings shall be provided for power connection entry. Evaporator coil condensate drain extended outside cabinet shall be provided. Lifting holes shall be provided for rigging. Bottom power entry shall be furnished.

Service Access — Cabinet panels shall be hinged with tool-less access for compressor/heating/controls, blower and air filter/economizer compartments.

Supply Air Blower — Centrifugal supply air blower shall have ball bearings and adjustable belt drive. Blower assembly shall slide out of unit for servicing. Motor mount base shall permit ease of motor changeover and belt tension adjustment. Blower wheel shall be statically and dynamically balanced. Blower shall be capable of delivering cfm (m³/s) at an external static pressure of inches water gauge (Pa) requiring bhp (W) and rev/min.

Condenser Fans — Direct drive propeller type condenser fans shall discharge vertically and be direct driven by a hp (W) motor. Fan motor shall have ball bearings and be permanently lubricated and inherently protected. Fans shall have a safety guard.

Air Filters — Disposable 2 inch (51 mm) thick pleated filters furnished shall have not less than sq. ft. (m²) of free area.

OPTIONAL ACCESSORIES

Additive Electric Heaters — The certified total heating capacity output shall be Btuh with kW input at volts power supply.

Electric heaters shall be available for factory or field installation. Heating elements shall be nichrome bare wire exposed directly to the air stream. Time delays shall bring the elements on and off in sequence with a time delay between each element. Limit controls shall provide overload and short circuit protection.

Unit Fuse Block — Shall be required for units with single point power supply and electric heat.

Terminal Block — Shall be required for units without disconnect switch but with single point power supply and electric heat.

Roof Mounting Frame — Furnish and install a steel roof mounting frame for bottom discharge and return air duct connection. It shall mate to the bottom perimeter of the equipment. When flashed into the roof it shall make a unit mounting curb and provide weatherproof duct connection and entry into the conditioned area. Height of frame shall be inches (mm). Flashing shall be the responsibility of the roofing contractor.

Economizer Section — Furnish and install economizer complete with recirculated air dampers, outside air dampers and controls. Low leakage dampers shall ride in nylon bearings. The economizer section shall provide for the introduction of outdoor air for minimum ventilation and free cooling. Integrated economizer control shall allow compressors to cycle for dehumidification and additional cooling, as needed, with up to 100% outdoor air intake. Damper actuator shall be opposing gear driven, 24 volt, fully modulating design. Plug-in control board (on unit IMC board) shall consist of adjustable minimum positioner, enthalpy setpoint and DIP switches for setting type of control logic used. Enthalpy control options shall consist of sensible temperature, global, outdoor enthalpy and differential enthalpy (outdoor and return air). Optional outdoor air hood (required) with filters shall be galvanized steel with a powdered enamel paint finish electrostatically bonded to the metal. Economizer shall be available for factory or field installation.

Gravity Exhaust Dampers — Pressure operated dampers shall be available for factory or field installation. Extruded aluminum dampers shall prevent blow-back and outdoor air infiltration during off cycle.

Power Exhaust Fan — Shall be available for all models with economizer (down-flow applications only). Direct drive propeller type fan shall exhaust air through optional gravity exhaust damper (required). Motor shall be overload protected. Fan shall be factory or field installed in-between economizer and gravity exhaust dampers.

Horizontal Conversion Kit — Shall be available for all models to provide duct covers for bottom supply and return air openings to convert unit to horizontal air flow.

Horizontal Gravity Exhaust Dampers — Pressure operated dampers shall be available for field installation in the return air duct. Extruded aluminum dampers shall prevent blow-back and outdoor air infiltration during off cycle.

Outdoor Air Damper Section — Optional outdoor dampers shall be available to provide outdoor air requirements of up to 25%. Models shall be available for manual or automatic operation. Dampers shall be opposing gear driven design. Damper section shall install internal to the unit. Optional outdoor air hood (required) with filters shall be galvanized steel with a powdered enamel paint finish electrostatically bonded to the metal. Dampers shall be available for factory or field installation.

Ceiling Diffusers — Furnish and install a (flush or stepdown) optional combination ceiling supply and return air diffuser. It shall be capable of not less than ft. (m) radius of effective throw. Supply and return transitions shall be available, for field installation in the roof mounting frame, to provide duct connection to the diffuser.

Control Systems — Shall provide a selection of control systems to automatically operate the mechanical equipment through the heating or cooling and ventilating cycles as required.

Dirty Filter Switch — Furnish and install pressure switch that indicates dirty filter, relays information to Integrated Modular Control.

Blower Proving Switch — Furnish and factory install air pressure switch to monitor blower operation.

Disconnect — Furnish and factory install unit disconnect switch.

Indoor Air Quality Sensor — Furnish and field install sensor to monitor CO₂ levels, relays information to Integrated Module Control which adjusts economizer dampers proportionately to the pollutant level.

Service Valves — Furnish and factory install fully serviceable brass service valves in discharge and liquid lines. Shall allow refrigerant pump down to high side of system for servicing of low side.

Smoke Detectors — Furnish and factory install photoelectric type smoke detector in either or both return air section and supply air section.

Corrosion Protection — Furnish and factory apply phenolic epoxy coating to either or both of the following:

Condenser coils with painted condenser base section. Evaporator coil with painted evaporator base section and painted blower housings.

Prepared for the guidance of architects, consulting engineers and mechanical contractors.

General — Furnish and install a single package air to air direct expansion mechanical cooling system and gas fired heating system, complete with automatic controls. The single package unit shall be a standard product of a firm regularly engaged in the manufacture of heating-cooling equipment.

The installed weight shall not be more than lbs. (kg). Entire unit shall have a width of not more than inches (mm), a depth of not more than inches (mm) and an overall height of not more than inches (mm). The equipment shall be shipped completely factory assembled, precharged, piped and wired internally ready for field connections. In addition, manufacturer shall test operate system at the factory before shipment.

Air Distribution — Equipment shall be capable of bottom (down-flow) or side (horizontal) handling of conditioned air. Horizontal air shall require optional horizontal roof mounting frame. All air distribution ducts shall be fiberglass or ga. galvanized steel insulated with inch (mm) thick lb./ft.³ (kg/m³) density fiberglass or equivalent.

Cooling System — The total certified cooling capacity shall not be less than Btuh (kW) with an evaporator air volume of cfm (l), an entering wet bulb air temperature of °F (°C), an entering dry bulb air temperature of °F (°C) and a condenser entering temperature of °F (°C). The compressor power input shall not exceed kW at these conditions.

The coils shall be non-ferrous construction with aluminum fins mechanically bonded to durable copper tubes. Coils shall be pressure leak tested. Coil face area shall be not less than sq. ft. (m²) (evaporator) and sq. ft. (m²) (condenser). Condenser coils shall be slab coil construction.

Multiple compressors shall be resiliently mounted, have overload protection and crankcase heaters. The refrigeration system shall have discharge suction and liquid line gauge ports, high pressure switches, low pressure switches, driers, freestat and full refrigerant charge. Optional service valves shall be available. All models shall have low ambient operation down to 15° F (-9.4°C).

Heating System — The heating capacity output shall be Btuh (kW) with a gas input of Btuh (kW).

Tubular heat exchanger and inshot type gas burners shall be constructed of aluminized steel. Controls shall consist of direct spark ignition, electronic flame sensor controls, flame rollout switch, limit controls and automatic redundant dual gas valve with staging control and combustion air proving switch on induced draft blower. Unit shall be available for use with LPG/propane as an option. Heat exchanger shall be removable for servicing. Complete service access shall be provided for controls and wiring.

Cabinet — Shall be galvanized steel with a powdered enamel paint finish electrostatically bonded to the metal. Cabinet panels where conditioned air is handled shall be fully insulated to prevent sweating and minimize sound. Openings shall be provided for power connection entry. Evaporator coil condensate drain extended outside cabinet shall be provided. Lifting holes shall be provided for rigging. Bottom power electrical/gas entry shall be furnished.

Service Access — Cabinet panels shall be hinged with tool-less access for compressor/heating/controls, blower and air filter/economizer compartments.

Supply Air Blower — Centrifugal supply air blower shall have ball bearings and adjustable belt drive. Blower assembly shall slide out of unit for servicing. Motor mount base shall permit ease of motor changeover and belt tension adjustment. Blower wheel shall be statically and dynamically balanced. Blower shall be capable of delivering cfm (m³/s) at an external static pressure of inches water gauge (Pa) requiring bhp (W) and rev/min.

Condenser Fans — Direct drive propeller type condenser fans shall discharge vertically and be direct driven by a hp (W) motor. Fan motor shall have ball bearings and be permanently lubricated and inherently protected. Fans shall have a safety guard.

Air Filters — Disposable 2 inch (51 mm) thick pleated filters furnished shall have not less than sq. ft. (m²) of free area.

OPTIONAL ACCESSORIES

Roof Mounting Frame — Furnish and install a steel roof mounting frame for bottom discharge and return air duct connection. It shall mate to the bottom perimeter of the equipment. When flashed into the roof it shall make a unit mounting curb and provide weatherproof duct connection and entry into the conditioned area. Height of frame shall be inches (mm). Flashing shall be the responsibility of the roofing contractor.

Economizer Section — Furnish and install economizer complete with recirculated air dampers, outside air dampers and controls. Low leakage dampers shall ride in nylon bearings. The economizer section shall provide for the introduction of outdoor air for minimum ventilation and free cooling. Integrated economizer control shall allow compressors to cycle for dehumidification and additional cooling, as needed, with up to 100% outdoor air intake. Damper actuator shall be opposing gear driven, 24 volt, fully modulating design. Plug-in control board (on unit IMC board) shall consist of adjustable minimum positioner, enthalpy set-point and DIP switches for setting type of control logic used. Enthalpy control options shall consist of sensible temperature, global, outdoor enthalpy and differential enthalpy (outdoor and return air). Optional outdoor air hood (required) with filters shall be galvanized steel with a powdered enamel paint finish electrostatically bonded to the metal. Economizer shall be available for factory or field installation.

Gravity Exhaust Dampers — Pressure operated dampers shall be available for factory or field installation. Extruded aluminum dampers shall prevent blow-back and outdoor air infiltration during off cycle.

Power Exhaust Fan — Shall be available for all models with economizer (down-flow applications only). Direct drive propeller type fan shall exhaust air through optional gravity exhaust damper (required). Motor shall be overload protected. Fan shall be factory or field installed in-between economizer and gravity exhaust dampers.

Horizontal Conversion Kit — Shall be available for all models to provide duct covers for bottom supply and return air openings to convert unit to horizontal air flow.

Horizontal Gravity Exhaust Dampers — Pressure operated dampers shall be available for field installation in the return air duct. Extruded aluminum dampers shall prevent blow-back and outdoor air infiltration during off cycle.

Outdoor Air Damper Section — Optional outdoor dampers shall be available to provide outdoor air requirements of up to 25%. Models shall be available for manual or automatic operation. Dampers shall be opposing gear driven design. Damper section shall install internal to the unit. Optional outdoor air hood (required) with filters shall be galvanized steel with a powdered enamel paint finish electrostatically bonded to the metal. Dampers shall be available for factory or field installation.

Ceiling Diffusers — Furnish and install a (flush or stepdown) optional combination ceiling supply and return air diffuser. It shall be capable of not less than ft. (m) radius of effective throw. Supply and return transitions shall be available, for field installation in the roof mounting frame, to provide duct connection to the diffuser.

Control Systems — Shall provide a selection of control systems to automatically operate the mechanical equipment through the heating or cooling and ventilating cycles as required.

Dirty Filter Switch — Furnish and install pressure switch that indicates dirty filter, relays information to Integrated Modular Control.

Blower Proving Switch — Furnish and factory install air pressure switch to monitor blower operation.

Disconnect — Furnish and factory install unit disconnect switch.

Indoor Air Quality Sensor — Furnish and field install sensor to monitor CO₂ levels, relays information to Integrated Module Control which adjusts economizer dampers proportionately to the pollutant level.

Service Valves — Furnish and factory install fully serviceable brass service valves in discharge and liquid lines. Shall allow refrigerant pump down to high side of system for servicing of low side.

Smoke Detectors — Furnish and factory install photoelectric type smoke detector in return air section and supply air section.

Corrosion Protection — Furnish and factory apply phenolic epoxy coating to either or both of the following:

Condenser coils with painted condenser base section. Evaporator coil with painted evaporator base section and painted blower housings.

Prepared for the guidance of architects, consulting engineers and mechanical contractors.

General — Furnish and install a single package air to air direct expansion mechanical heat pump system, complete with automatic controls. The single package unit shall be a standard product of a firm regularly engaged in the manufacture of heating-cooling equipment.

The installed weight shall not be more than lbs. (kg). Entire unit shall have a width of not more than inches (mm), a depth of not more than inches (mm) and an overall height of not more than inches (mm). The equipment shall be shipped completely factory assembled, precharged, piped and wired internally ready for field connections. In addition, manufacturer shall test operate system at the factory before shipment.

Air Distribution — Equipment shall be capable of bottom (down-flo) or side (horizontal) handling of conditioned air. Horizontal air shall require optional horizontal conversion kit. All air distribution ducts shall be fiberglass or ga. galvanized steel insulated with inch (mm) thick lb./ft.³ (kg/m³) density fiberglass or equivalent.

Cooling System — The total certified cooling capacity shall not be less than Btuh (kW) with an indoor coil air volume of cfm (m³/s), an entering wet bulb air temperature of °F (°C), an entering dry bulb air temperature of °F (°C) and an outdoor coil entering temperature of °F (°C). The compressor power input shall not exceed kW at these conditions.

Heating System — The total certified heating capacity shall not be less than Btuh (kW) with an indoor coil air volume of cfm (m³/s), an entering dry bulb temperature of °F (°C) and an outdoor coil entering air temperature of °F (°C). The total compressor power input shall not exceed kW at the above conditions.

The coils shall be non-ferrous construction with aluminum fins mechanically bonded to durable copper tubes. Coils shall be pressure leak tested. Coil face area shall be not less than sq. ft. (m²) (indoor coil) and sq. ft. (m²) (outdoor coil). Outdoor coils shall be formed coil construction.

Multiple compressors shall be resiliently mounted, have overload protection and crankcase heaters. The refrigeration system shall have discharge suction and liquid line gauge ports, high pressure switches, low pressure switches, driers, defrost control, check and expansion valves, reversing valves, accumulators and full refrigerant charge. All models shall have low ambient cooling operation down to 15° F (-9.4° C).

Cabinet — Shall be galvanized steel with a powdered enamel paint finish electrostatically bonded to the metal. Cabinet panels where conditioned air is handled shall be fully insulated to prevent sweating and minimize sound. Openings shall be provided for power connection entry. Indoor coil condensate drain extended outside cabinet shall be provided. Lifting holes shall be provided for rigging. Bottom power entry shall be furnished.

Service Access — Cabinet panels shall be hinged with tool-less access for compressor/heating/controls, blower and air filter/economizer compartments.

Supply Air Blower — Centrifugal supply air blower shall have ball bearings and adjustable belt drive. Blower assembly shall slide out of unit for servicing. Motor mount base shall permit ease of motor changeover and belt tension adjustment. Blower wheel shall be statically and dynamically balanced. Blower shall be capable of delivering cfm (m³/s) at an external static pressure of inches water gauge (Pa) requiring bhp (W) and rev/min.

Outdoor Coil Fans — Direct drive propeller type outdoor coil fans shall discharge vertically and be direct driven by a hp (W) motor. Fan motor shall have ball bearings and be permanently lubricated and inherently protected. Fans shall have a safety guard.

Air Filters — Disposable 2 inch (51 mm) thick pleated filters furnished shall have not less than sq. ft. (m²) of free area.

OPTIONAL ACCESSORIES

Supplemental Electric Heaters — The certified total heating capacity output shall be Btuh with kW input at volts power supply.

Electric heaters shall be available for factory or field installation. Heating elements shall be nichrome bare wire exposed directly to the air stream. Time delays shall bring the elements on and off in sequence with a time delay between each element. Limit controls shall provide overload and short circuit protection.

Unit Fuse Block — Shall be required for units with single point power supply and electric heat.

Terminal Block — Shall be required for units without disconnect switch but with single point power supply and electric heat.

Roof Mounting Frame — Furnish and install a steel roof mounting frame for bottom discharge and return air duct connection. It shall mate to the bottom perimeter of the equipment. When flashed into the roof it shall make a unit mounting curb and provide weatherproof duct connection and entry into the conditioned area. Height of frame shall be inches (mm). Flashing shall be the responsibility of the roofing contractor.

Economizer Section — Furnish and install economizer complete with recirculated air dampers, outside air dampers and controls. Low leakage dampers shall ride in nylon bearings. The economizer section shall provide for the introduction of outdoor air for minimum ventilation and free cooling. Integrated economizer control shall allow compressors to cycle for dehumidification and additional cooling, as needed, with up to 100% outdoor air intake. Damper actuator shall be opposing gear driven, 24 volt, fully modulating design. Plug-in control board (on unit IMC board) shall consist of adjustable minimum positioner, enthalpy set-point and DIP switches for setting type of control logic used. Enthalpy control options shall consist of sensible temperature, global, outdoor enthalpy and differential enthalpy (outdoor and return air). Optional outdoor air hood (required) with filters shall be galvanized steel with a powdered enamel paint finish electrostatically bonded to the metal. Economizer shall be available for factory or field installation.

Gravity Exhaust Dampers — Pressure operated dampers shall be available for factory or field installation. Extruded aluminum dampers shall prevent blow-back and outdoor air infiltration during off cycle.

Power Exhaust Fan — Shall be available for all models with economizer (down-flow applications only). Direct drive propeller type fan shall exhaust air through optional gravity exhaust damper (required). Motor shall be overload protected. Fan shall be factory or field installed in-between economizer and gravity exhaust dampers.

Horizontal Conversion Kit — Shall be available for all models to provide duct covers for bottom supply and return air openings to convert unit to horizontal air flow.

Horizontal Gravity Exhaust Dampers — Pressure operated dampers shall be available for field installation in the return air duct. Extruded aluminum dampers shall prevent blow-back and outdoor air infiltration during off cycle.

Outdoor Air Damper Section — Optional outdoor dampers shall be available to provide outdoor air requirements of up to 25%. Models shall be available for manual or automatic operation. Dampers shall be opposing gear driven design. Damper section shall install internal to the unit. Optional outdoor air hood (required) with filters shall be galvanized steel with a powdered enamel paint finish electrostatically bonded to the metal. Dampers shall be available for factory or field installation.

Ceiling Diffusers — Furnish and install a (flush or stepdown) optional combination ceiling supply and return air diffuser. It shall be capable of not less than ft. (m) radius of effective throw. Supply and return transitions shall be available, for field installation in the roof mounting frame, to provide duct connection to the diffuser.

Control Systems — Shall provide a selection of control systems to automatically operate the mechanical equipment through the heating or cooling and ventilating cycles as required.

Dirty Filter Switch — Furnish and install pressure switch that indicates dirty filter, relays information to Integrated Modular Control.

Blower Proving Switch — Furnish and factory install air pressure switch to monitor blower operation.

Disconnect — Furnish and factory install unit disconnect switch.

Indoor Air Quality Sensor — Furnish and field install sensor to monitor CO₂ levels, relays information to Integrated Module Control which adjusts economizer dampers proportionately to the pollutant level.

Smoke Detectors — Furnish and factory install photoelectric type smoke detector in return air section and supply air section.

Corrosion Protection — Furnish and factory apply phenolic epoxy coating to either or both of the following:
Condenser coils with painted condenser base section. Evaporator coil with painted evaporator base section and painted blower housings.

**LCA 102, 120 AND 150 UNITS SHOWN WITH
OPTIONAL ECONOMIZER DAMPERS, POWER EXHAUST FANS, CONVENIENCE OUTLET, UNIT DISCONNECT
CORNER WEIGHTS — lbs. (kg)**

Model Number	AA		BB		CC		DD	
	lbs.	kg	lbs.	kg	lbs.	kg	lbs.	kg
LCA102 Base Unit	270	122	250	113	280	127	320	145
LCA102 Maximum Unit	340	154	300	136	330	150	380	172
LCA120 Base Unit	270	122	250	113	290	132	320	145
LCA120 Maximum Unit	350	159	310	141	340	154	390	177
LCA150 Base Unit	280	127	260	118	290	132	340	154
LCA150 Maximum Unit	350	159	300	136	340	154	400	181

Base Unit — The standard unit with NO OPTIONS.
Maximum Unit — The standard unit with ALL OPTIONS Installed. (Economizer, Power Exhaust Fans and Controls)

CENTER OF GRAVITY — inches (mm)

Model Number	EE		FF	
	inch	mm	inch	mm
LCA102 Base Unit	47	1194	21-1/2	546
LCA102 Maximum Unit	45-1/2	1156	23-1/2	597
LCA120 Base Unit	47	1194	21-1/2	546
LCA120 Maximum Unit	45-1/2	1156	23-1/2	597
LCA150 Base Unit	46	1168	21	533
LCA150 Maximum Unit	45	1143	23	584

Base Unit — The standard unit with NO OPTIONS.
Maximum Unit — The standard unit with ALL OPTIONS Installed. (Economizer, Power Exhaust Fans, High and Controls)

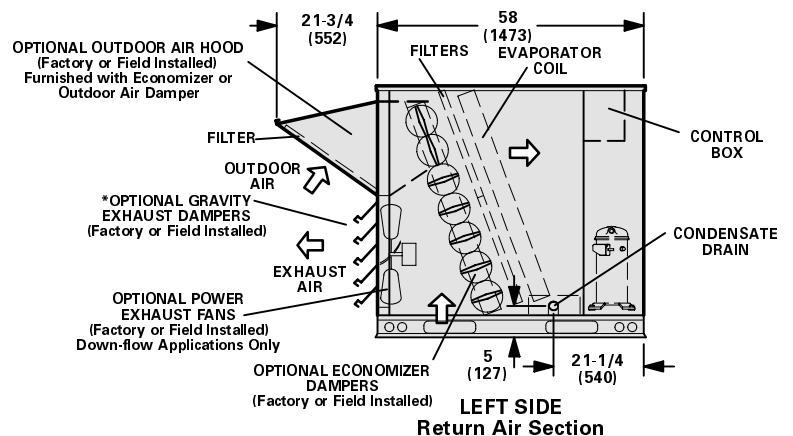
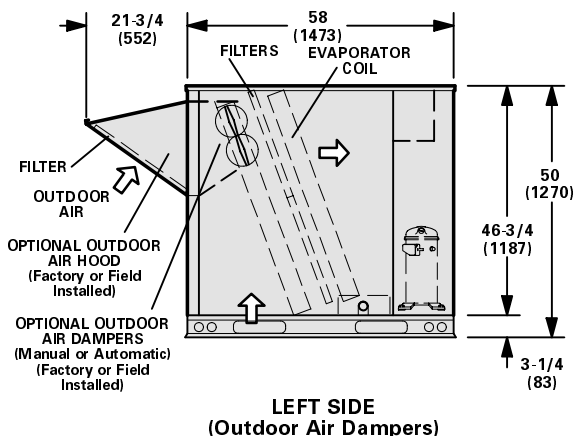
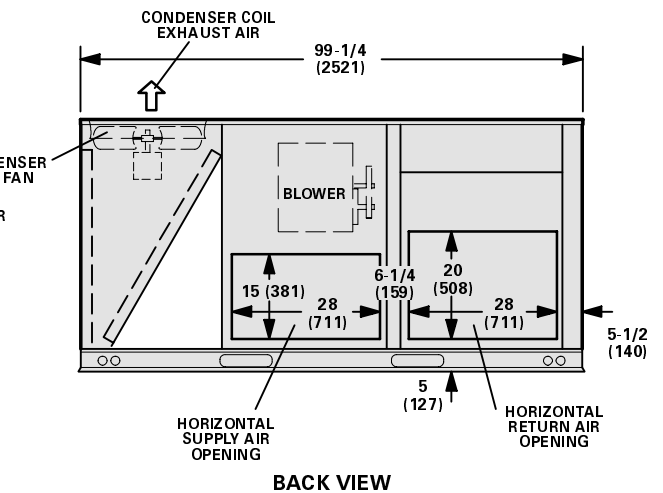
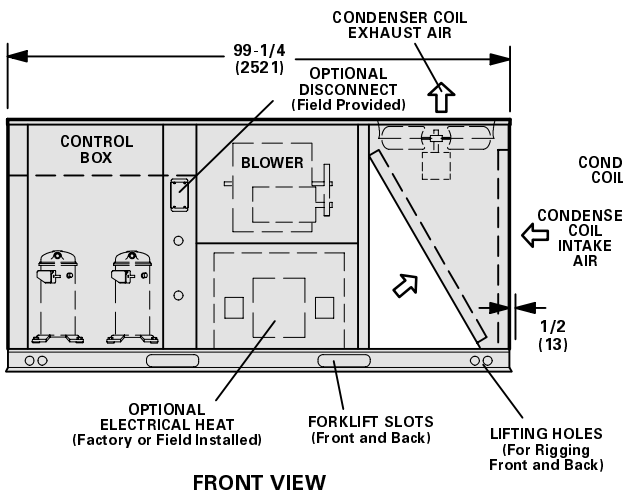
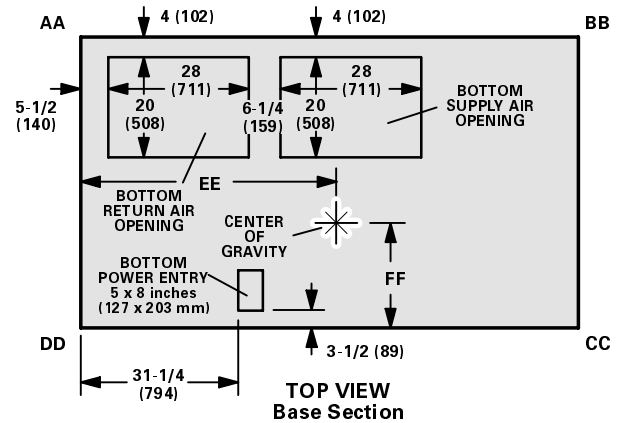
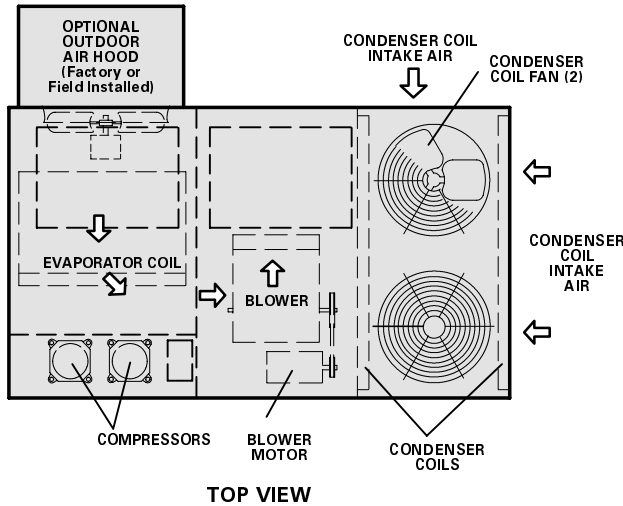

*NOTE — Field Installed in Return Air Duct for Horizontal Applications.

**LGA102, 120 AND 150 UNITS SHOWN WITH
OPTIONAL ECONOMIZER DAMPERS, POWER EXHAUST FANS, CONVENIENCE OUTLET, UNIT DISCONNECT
CORNER WEIGHTS — lbs. (kg)
CENTER OF GRAVITY — inches (mm)**

Model Number	AA		BB		CC		DD	
	lbs.	kg	lbs.	kg	lbs.	kg	lbs.	kg
LGA102 Base Unit	280	127	260	118	300	136	330	150
LGA102 Maximum Unit	350	159	320	145	350	159	400	181
LGA120 Base Unit	290	132	260	118	300	136	330	150
LGA120 Maximum Unit	360	163	330	150	360	163	410	186
LGA150 Base Unit	300	136	270	122	300	136	350	159
LGA150 Maximum Unit	370	168	320	145	350	159	420	191

Model Number	EE		FF	
	inch	mm	inch	mm
LGA102 Base Unit	47	1194	21-1/2	546
LGA102 Maximum Unit	46	1168	23-1/2	597
LGA120 Base Unit	47	1194	21-1/2	546
LGA120 Maximum Unit	46	1168	23-1/2	597
LGA150 Base Unit	46	1168	21	533
LGA150 Maximum Unit	45	1143	23	584

Base Unit — The standard unit with NO OPTIONS.
Maximum Unit — The standard unit with ALL OPTIONS Installed. (Economizer, Power Exhaust Fans, High Input Heating and Controls)

Base Unit — The standard unit with NO OPTIONS.
Maximum Unit — The standard unit with ALL OPTIONS Installed. (Economizer, Power Exhaust Fans, High Input Heating and Controls)

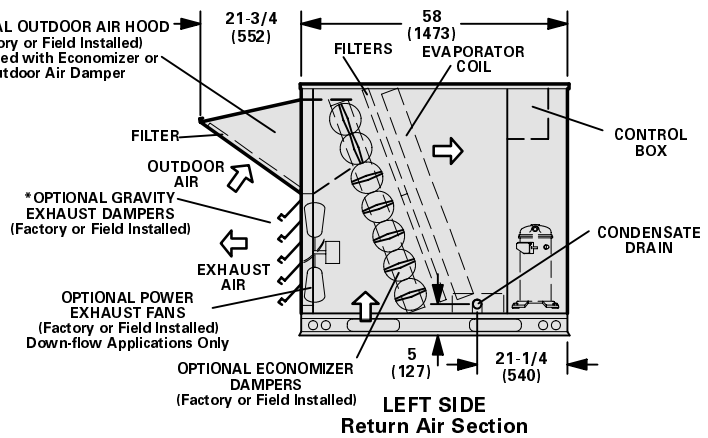
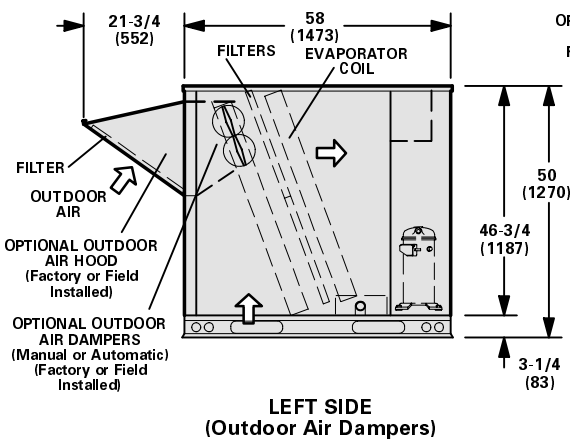
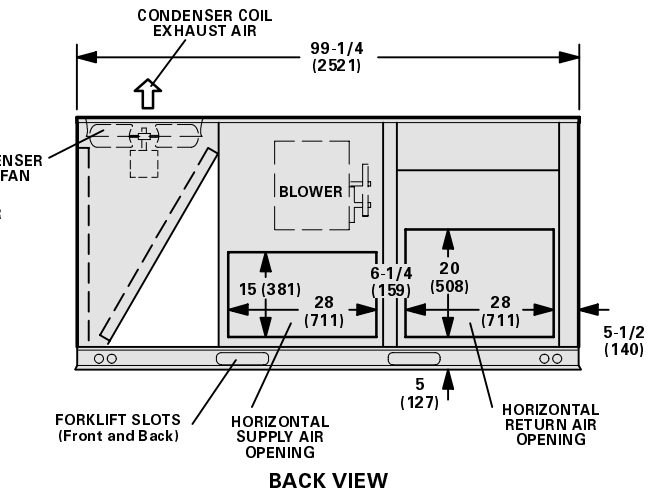
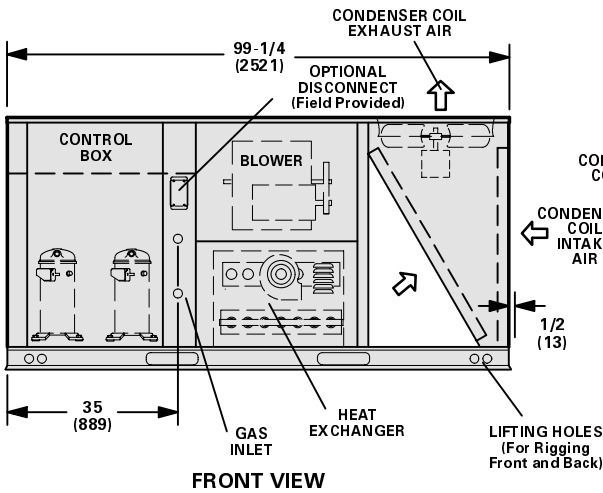
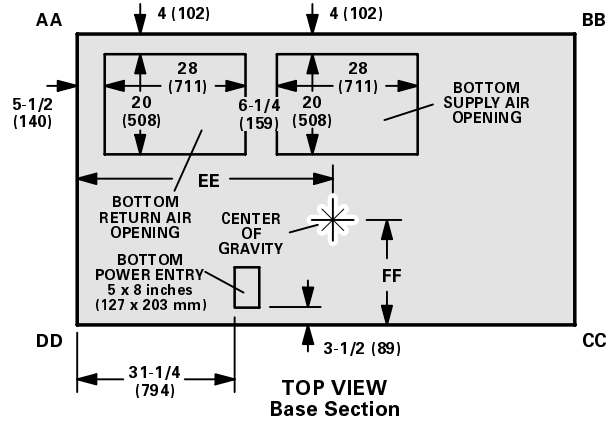
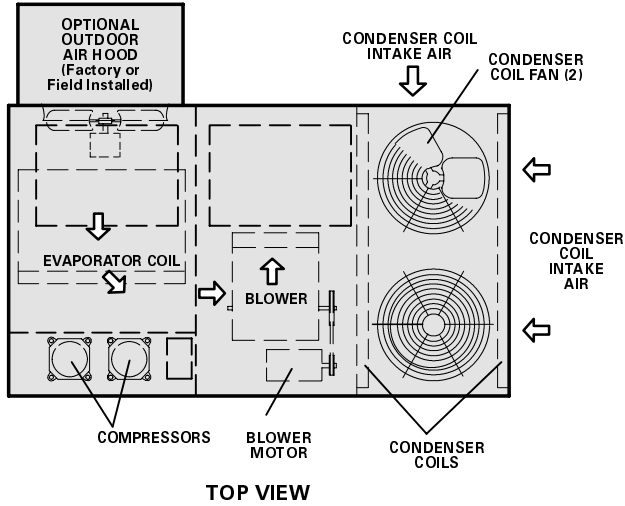

*NOTE — Field Installed in Return Air Duct for Horizontal Applications.

**LHA090 AND 120 UNITS SHOWN WITH
OPTIONAL ECONOMIZER DAMPERS, POWER EXHAUST FANS, CONVENIENCE OUTLETS, UNIT DISCONNECT
CORNER WEIGHTS — lbs. (kg)**

Model Number	AA		BB		CC		DD	
	lbs.	kg	lbs.	kg	lbs.	kg	lbs.	kg
LHA090 Base Unit	290	132	260	118	300	136	330	150
LHA090 Maximum Unit	350	159	310	141	340	154	390	177
LHA120 Base Unit	300	136	270	122	310	141	350	159
LHA120 Maximum Unit	360	163	320	145	350	159	410	186

Base Unit — The standard unit with NO OPTIONS.
Maximum Unit — The standard unit with ALL OPTIONS Installed. (Economizer, Power Exhaust Fans and Controls)

CENTER OF GRAVITY — inches (mm)

Model Number	EE		FF	
	inch	mm	inch	mm
LHA090 Base Unit	47	1194	21-1/2	546
LHA090 Maximum Unit	46	1168	24-1/2	622
LHA120 Base Unit	46	1168	21-1/2	546
LHA120 Maximum Unit	45	1143	24-1/2	622

Base Unit — The standard unit with NO OPTIONS.
Maximum Unit — The standard unit with ALL OPTIONS Installed. (Economizer, Power Exhaust Fans and Controls)

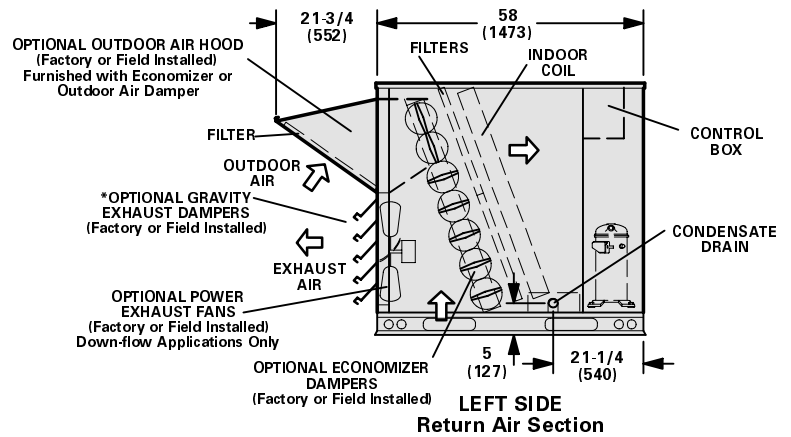
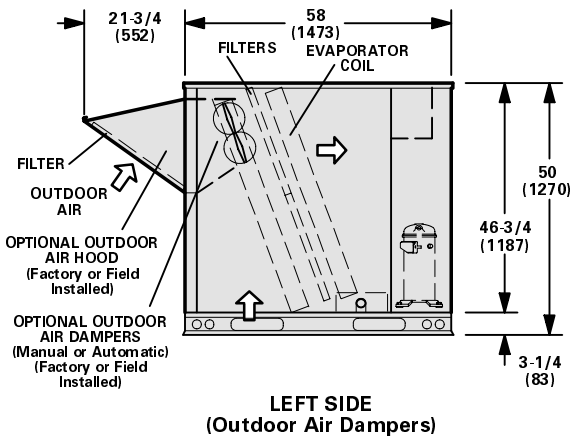
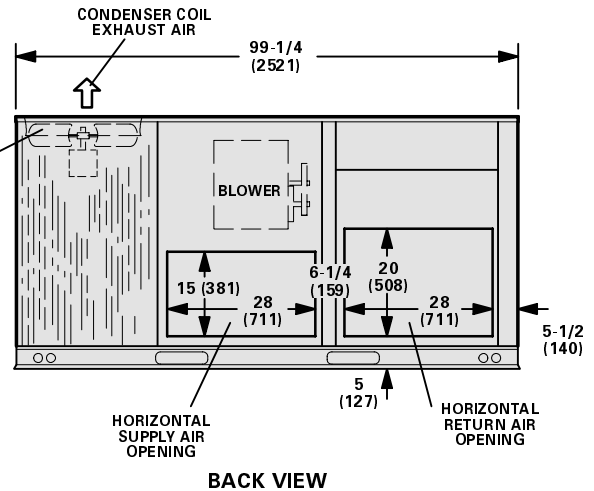
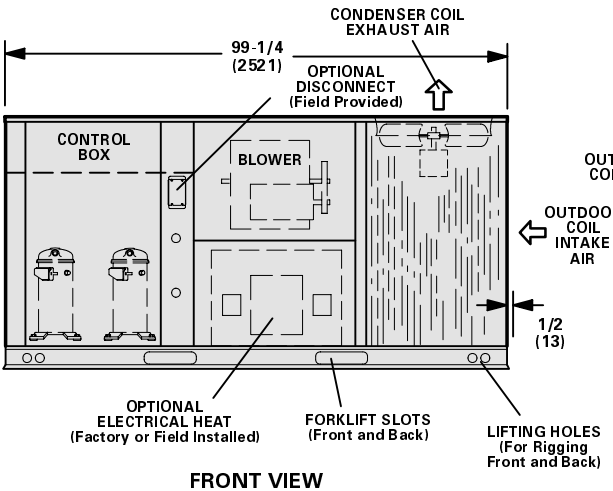
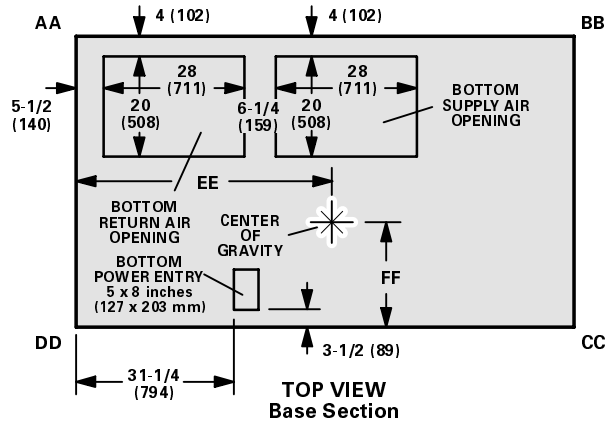
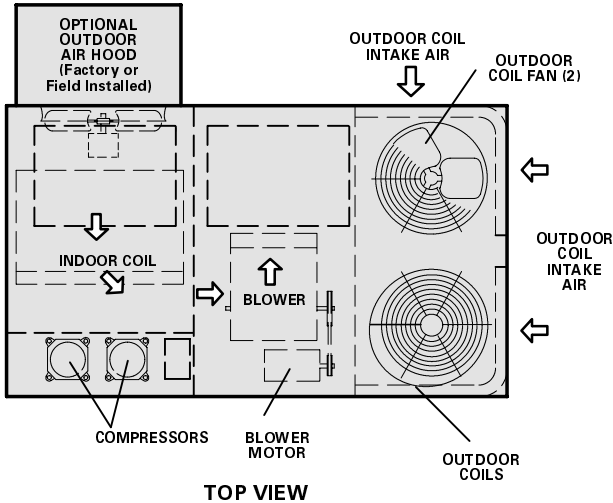

*NOTE — Field Installed in Return Air Duct for Horizontal Applications.

LARMF10/15-14 AND LARMF10/15-24 ROOF MOUNTING FRAMES WITH DOUBLE DUCT OPENING FOR -090, -102, -120 AND -150 UNITS

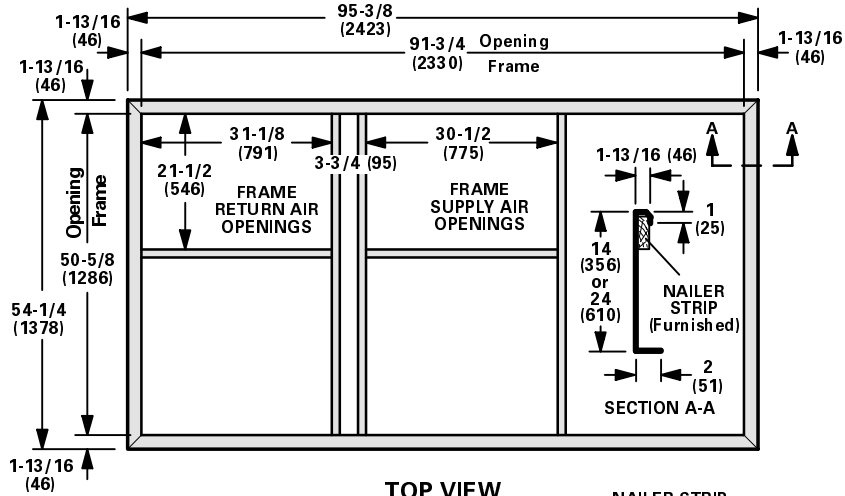

TOP VIEW

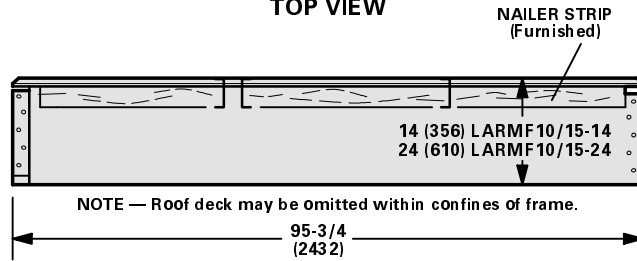

SIDE VIEW

LARMF10/15-14 AND LARMF10/15-24 ROOF MOUNTING FRAMES WITH LASRT SUPPLY AND RETURN AIR TRANSITIONS FOR FD11 AND RTD11 CEILING DIFFUSERS

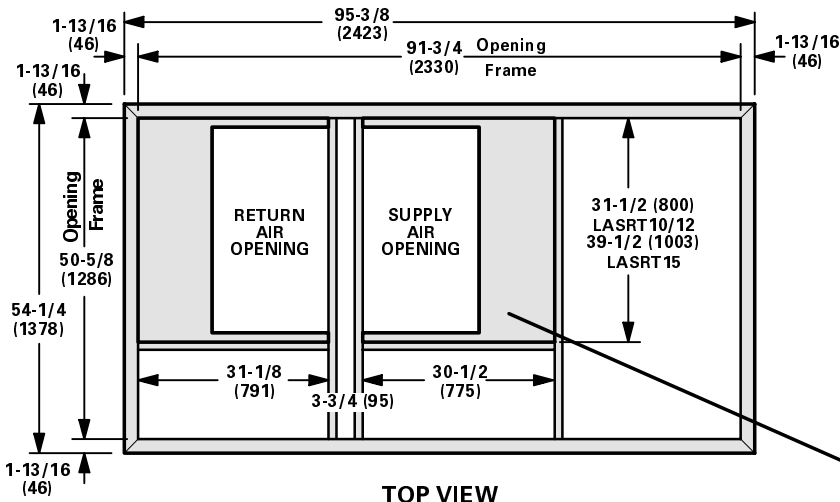

TOP VIEW

LASRT TRANSITION DETAIL

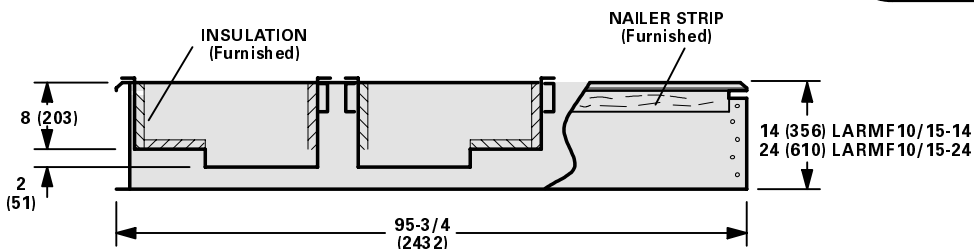
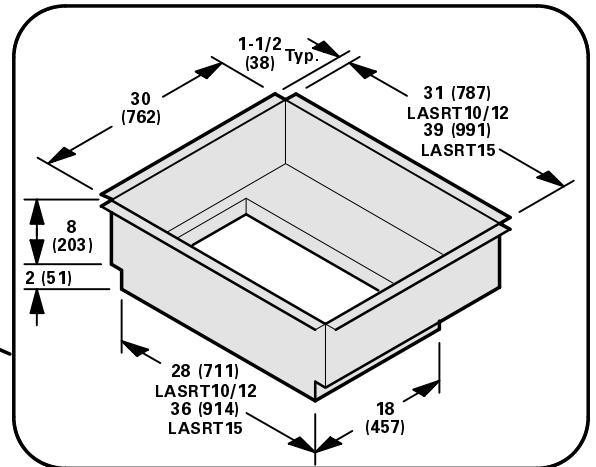

SIDE VIEW

ROOF MOUNTING FRAME SPECIFICATIONS

Roof Mounting frame is rigid enough to be spanned over its entire length or cantilevered if supported on both sides of center of gravity.

Roof Mounting Frame	LARMF10/15-14	LARMF10/15-24
*Moment of inertia (I) (in. ⁴) (cm ⁴)	39 (1634)	160 (6639)
*Section modulus $\frac{I}{C}$ (in. ³) (cm ³)	5.5 (90)	13.1 (512)
Frame weight. (lb/ft) (kg/m) of length	5.5 (8.2)	8.5 (12.7)
Design strength (psi) (kPa)	20,000 (137,900)	

*Includes both sides of frame.

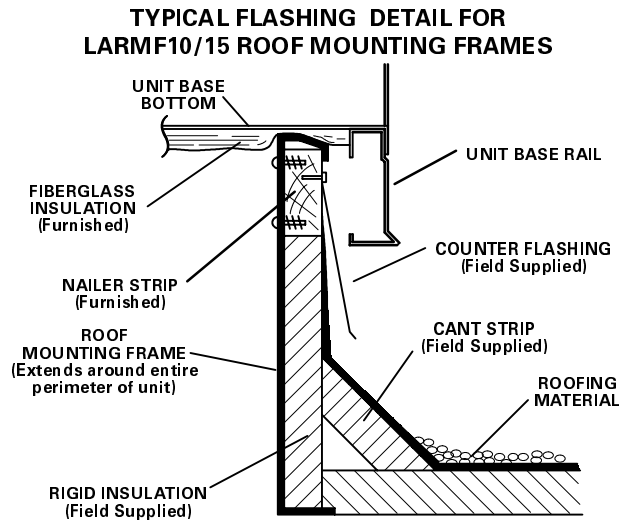

**RTD11-135 AND RTD11-185
STEP-DOWN CEILING DIFFUSER**

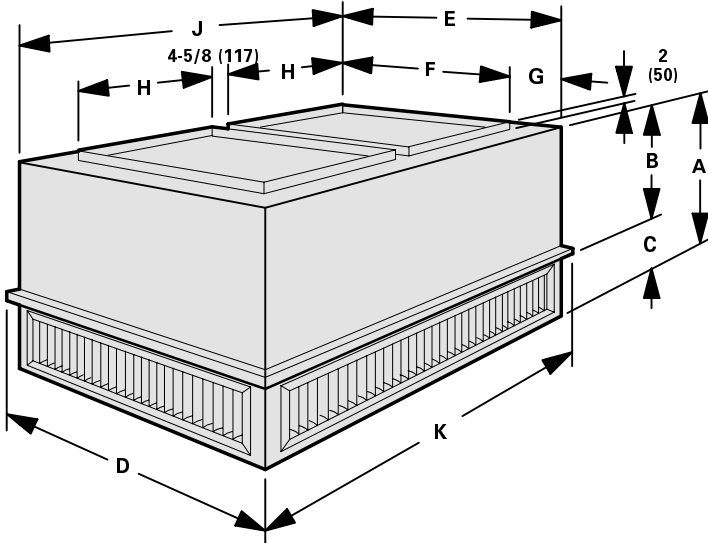

Model Number	A		B		C		D		E	
	inch	mm	inch	mm	inch	mm	inch	mm	inch	mm
RTD11-135	28	711	18-7/8	479	9-1/8	232	35-5/8	905	33-5/8	854
RTD11-185	34	864	23-7/8	606	10-1/8	257	47-5/8	1210	45-5/8	1159

Model Number	F		G		H		J		K	
	inch	mm	inch	mm	inch	mm	inch	mm	inch	mm
RTD11-135	28	711	2-13/16	71	18	457	45-5/8	1159	47-5/8	1210
RTD11-185	36	914	4-13/16	122	18	457	45-5/8	1159	47-5/8	1210

**FD11-135 AND FD11-185
FLUSH CEILING DIFFUSER**

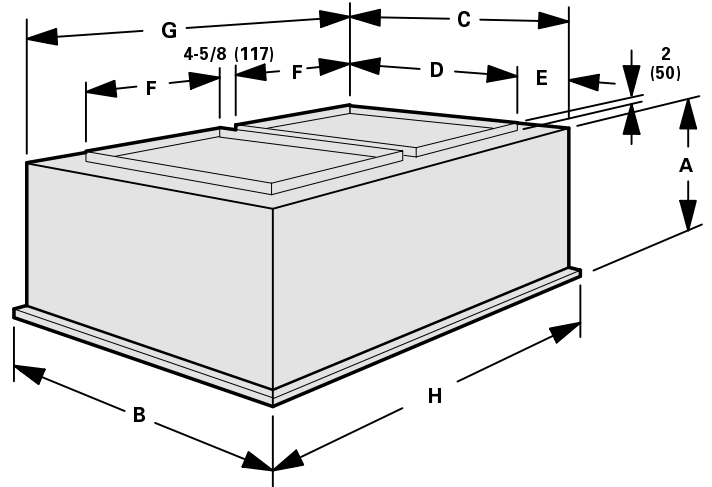

Model Number	A		B		C		D	
	inch	mm	inch	mm	inch	mm	inch	mm
FD11-135	24-1/8	613	35-5/8	905	33-5/8	854	28	711
FD11-185	30-1/8	613	47-5/8	1210	45-5/8	1159	36	914

Model Number	E		F		G		H	
	inch	mm	inch	mm	inch	mm	inch	mm
FD11-135	2-13/16	71	18	457	45-5/8	1159	47-5/8	1210
FD11-185	4-13/16	122	18	457	45-5/8	1159	47-5/8	1210

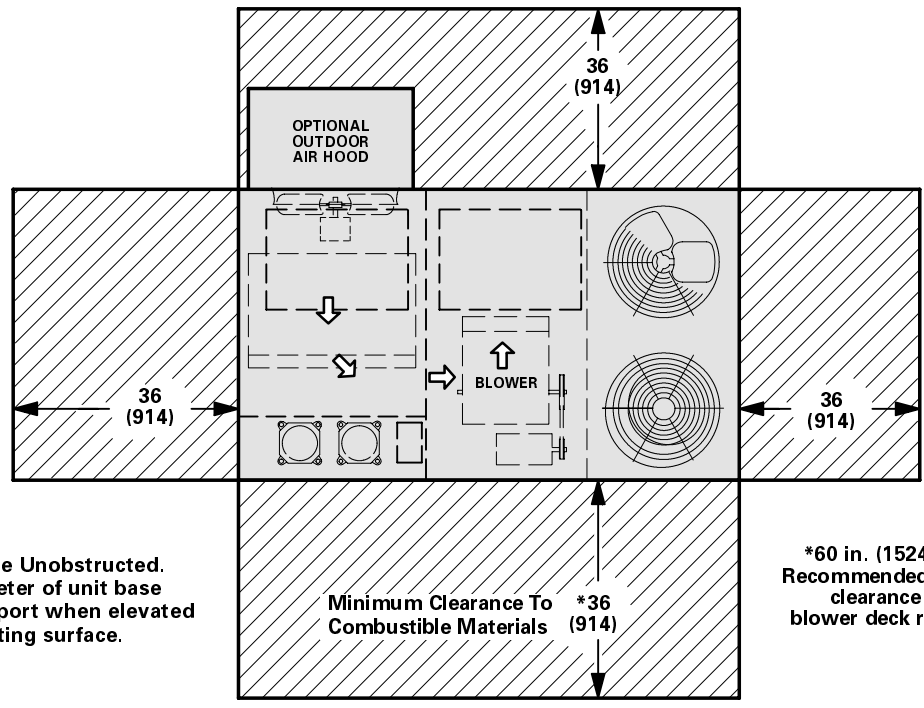

NOTE — Top Clearance Unobstructed.
NOTE — Entire perimeter of unit base requires support when elevated above mounting surface.