



**PACKAGED COOLING - 50HZ**

**CHA16-072-090-120-150**

21.1, 26.4, 35.2 and 43.8 kW  
(6, 7.5, 10 and 12-1/2 Ton)

Cooling Capacity - 19.0 to 37.5 kW (19 500 to 38 400 kcal) (65 000 to 128 000 Btuh)

Optional Electric Heat - 10.0 to 50.0 kW (10 200 to 51 200 kcal)

Bulletin #490097  
September 2000

Supersedes September 1999

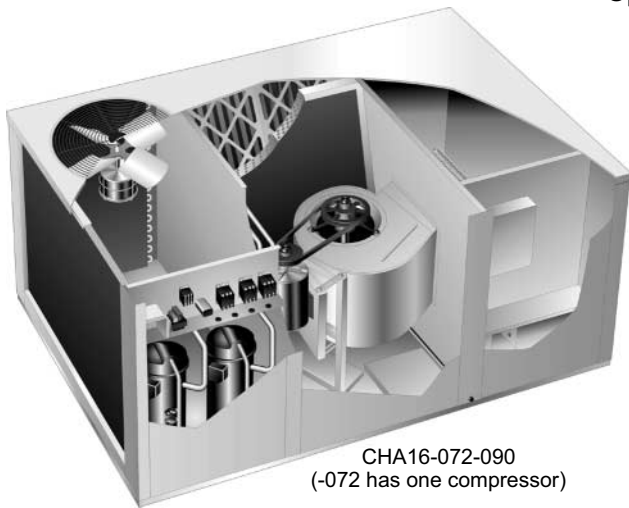

CHA16-072-090  
(-072 has one compressor)

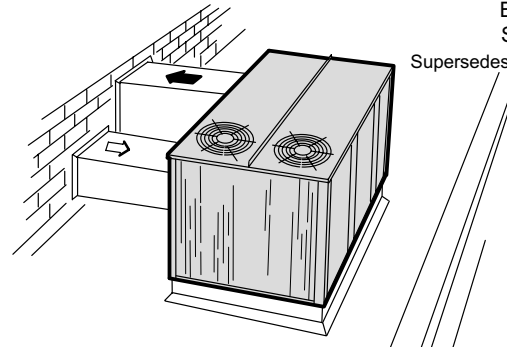

Horizontal (Side) Supply and Return Air Installation  
With RMF16 Roof Mounting Frame.

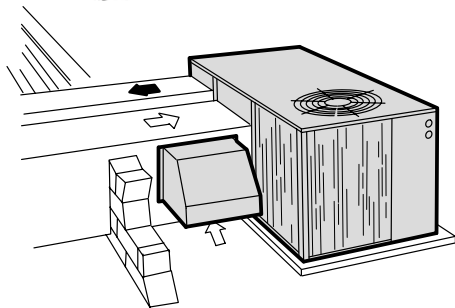

Horizontal (Side) Supply and Return Air  
Installation with OAD16 Outdoor Air Dampers.

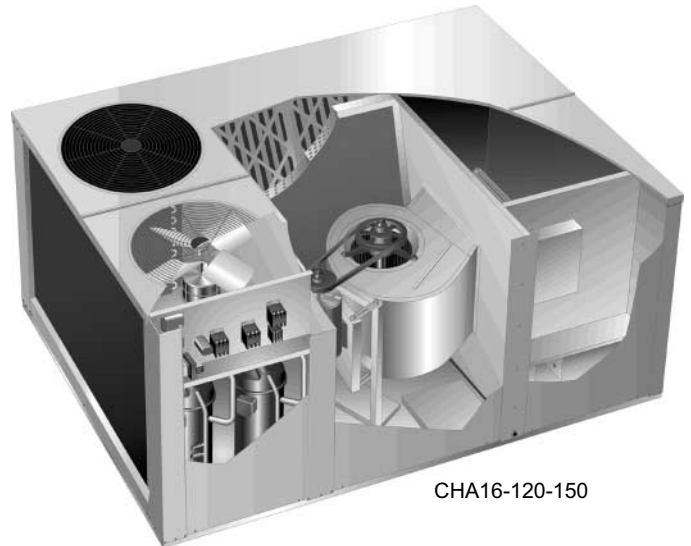

CHA16-120-150

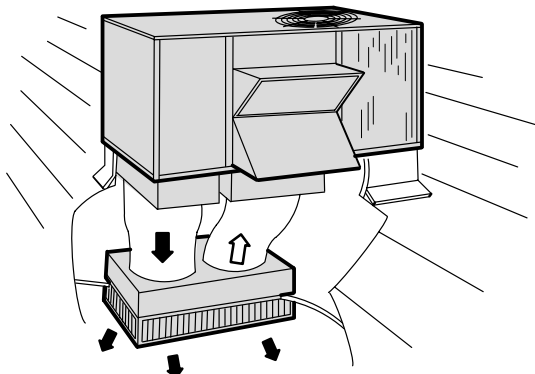

Down-Flow Supply and Return Air Installation With RMF16 Roof  
Mounting Frame, REMD16 Economizer and RTD11 Ceiling Diffuser.

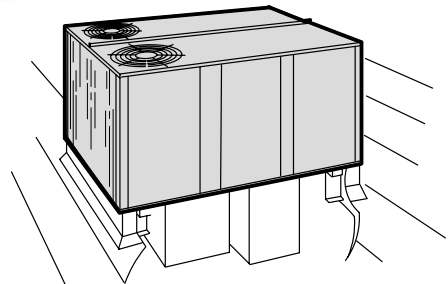

Down-Flow Supply and Return Air Installation  
With RMF16 Roof Mounting Frame.

**MODEL NUMBER IDENTIFICATION**

**CHA 16 - 072 - 1 M**

Unit Type  
CHA = Packaged Cooling Unit

Series

Cooling Capacity kW (Tons)

- 072 - 21.1 (6)
- 090 - 26.4 (7)
- 120 - 35.2 (10)
- 150 - 43.8 (12.5)

Voltage  
M = 380/420v-3 phase-50hz

Minor Revision Number

NOTE - Due to Lennox' ongoing commitment to quality, Specifications, Ratings and Dimensions subject to change without notice and without incurring liability. Improper installation, adjustment, alteration, service or maintenance can cause property damage or personal injury. Installation and service must be performed by a qualified installer and servicing agency.

## FEATURES

### Air Flow Choice

- Bottom (down-flow) or horizontal (side) supply and return air.

### Cabinet

- Constructed of heavy gauge galvanized steel.
- Powdered enamel paint finish.
- Removable cabinet panels allow service access.
- Base section and cabinet panels exposed to conditioned air lined with thick fiberglass insulation.
- Electrical inlets provided in cabinet base and evaporator section cabinet panel for wiring entry.
- Control box with factory installed controls conveniently located for service access.
- Evaporator coil condensate drain connection extends outside cabinet for ease of connection.
- Lifting brackets furnished for handling and rigging.

### Coil Construction (Evaporator and Condenser)

- Extra large surface area and circuiting of coils provide maximum cooling efficiency, excellent heat transfer and low air resistance.
- Constructed of precisely spaced ripple-edged aluminum fins fitted to copper tubes.
- Fins equipped with collars that grip tubing for maximum contact area.
- Flared shoulder tubing connections and silver soldering provide tight, leakproof joints.
- Long life copper tubing is easy to field service.
- Coil is factory tested under high pressure to insure leakproof construction.
- Evaporator coil is face split with separate circuits. Each circuit has its separate expansion valve, compressor and refrigerant charge.

### Compressors

- Copeland® Compliant Scroll® type for high efficiency.
- 072 model has one compressor, 090, 120 and 150 models have two compressors.

### Condenser Coils

- Formed coil construction.

### Condenser Fans

- 072 and 090 models have a single fan, 120 and 150 models have two fans.
- Direct drive fan(s) draw large air volumes uniformly through condenser coils and discharges it vertically.
- Fan orifice design and low fan tip speed keeps operating sound level at a minimum.
- Uniform air flow through the coil results in high refrigerant cooling capacity.
- Corrosion resistant polyvinyl chloride (PVC) coated steel wire fan guard(s) furnished.

### Condenser Fan Motors

- Fan motor has ball bearings and is permanently lubricated, overload protected and resiliently mounted.

### Filters

- Disposable frame type, 51 mm (2 inch) thick, commercial grade filters are furnished as standard.

### Refrigeration System

- Consists of: compressors, condenser coil and direct drive fan(s), evaporator coil and belt drive blower, expansion valves, high capacity driers, high pressure switches (072-090 only), full refrigerant charge, freezestats (prevents coil freeze-up during low ambient operation), independent refrigerant circuits (allows staging), low ambient cooling operation down to -1°C (30°F) without additional controls.

### Supply Air Blower

- Belt drive.
- Forward curved blades with double inlet.
- Statically and dynamically balanced.
- Permanently lubricated self aligning sleeve bearings with adjustable pulley.

### Supply Air Motor

- Overload protected, equipped with ball bearings.
- Motor mounting base permits quick and simple motor changeover, belt tension adjustment or belt changing.
- Adjustable motor pulley allows for variable speed adjustments.

### Tested

- Units have been tested in the Lennox Research Laboratory Environmental Test Rooms which meet American Society of Heating, Refrigeration and Air-Conditioning Engineers (ASHRAE) Standard 37 requirements.
- Rated test conditions are those included in Air Conditioning and Refrigeration Institute (ARI) Standard 210/240-95 while operating at rated voltage and air volumes.
- Sound rating number rated at test conditions included in Air Conditioning and Refrigeration Institute (ARI) Standard 270-96.
- Units and components within are bonded for grounding to meet safety standards for servicing required by Underwriter's Laboratories (U.L.) and the International Electrotechnical Commission (IEC).
- Blower data is from unit tests conducted in the Lennox Laboratory air test chamber.

## OPTIONAL ACCESSORIES (MUST BE ORDERED EXTRA)

Item	CHA16-072	CHA16-090	CHA16-120	CHA16-150
<b>Bottom Power Entry</b>	LB-55757CA (34G70) - 5 kg (12 lbs.)			
<b>Coil Guard</b> - Polyvinyl chloride (PVC) coated steel wire guards to protect outdoor coil. Not used with Hail Guards.	60L31		60L32	
<b>Control Systems</b>	See Optional Temperature Controls Systems			
<b>Crankcase Heaters</b> - Ensures proper compressor lubrication at all times. Temperature actuated.	67K89	49K11	67K89	
<b>Differential Enthalpy Control</b> - For use with economizer dampers, solid-state return air sensor allows selection between outdoor air and return air (whichever has lowest enthalpy)	54G44			

<b>OPTIONAL ACCESSORIES (MUST BE ORDERED EXTRA)</b>				
Item	CHA16-072	CHA16-090	CHA16-120	CHA16-150
<b>Diffusers (Step-Down)</b> - Aluminum grilles, double deflection louvers, large center grille, insulated diffuser box with flanges, hanging rings furnished, interior transition (even air flow), internally sealed (prevents recirculation), adapts to T-bar ceiling grids or plaster ceilings	RTD11-95 - 57 kg (125 lbs.)		RTD11-135 - 93 kg (205 lbs.)	
<b>Diffusers (Flush)</b> - Aluminum grilles, fixed blade louvers, large center grille, insulated diffuser box with flanges, hanging rings furnished, interior transition (even air flow), internally sealed (prevents recirculation), adapts to T-bar ceiling grids or plaster ceilings	FD11-95 - 43 kg (95 lbs.)		FD11-135 - 79 kg (174 lbs.)	
<b>Transitions (Supply and Return)</b> - Used with diffusers, installs in roof mounting frame, galvanized steel construction, flanges furnished for duct connection, fully insulated	SRT16-09 - 17 kg (38 lbs.)		SRT16-12 - 17 kg (38 lbs.)	
<b>Economizer Dampers (Down-Flow)</b> - Mechanically linked recirculated air and outdoor air dampers, plug-in connections to unit, nylon bearings, stainless steel seals (outdoor dampers), 24 volt fully modulating spring return damper motor, adjustable minimum damper position switch, mixed air controller, solid-state adjustable outdoor air enthalpy control, 0 to 100% outdoor air adjustable, gravity exhaust air dampers furnished, powdered enamel paint finish NOTE - Economizer Damper Hood is required and must be ordered separately (see below)	Model Number	REMD16M-09 Dampers	REMD16M-12 Dampers	REMD16M-15 Dampers
	Net Weight	27 kg (60 lbs.)	36 kg (80 lbs.)	45 kg (100 lbs.)
	Net face area	0.20 m <sup>2</sup> (2.1 ft <sup>2</sup> )	0.26 m <sup>2</sup> (2.8 ft <sup>2</sup> )	0.33 m <sup>2</sup> (3.6 ft <sup>2</sup> )
<b>Economizer Damper Hood (Down-flow)</b> - Required with REMD16M economizer dampers (see above). Must be ordered separately. Includes one cleanable aluminium mesh frame filter.	Order Number	<b>27L58</b>	<b>27L60</b>	<b>48L00</b>
	Number of filters	1		
	Size of Filter	mm 819 x 419 x 25	819 x 546 x 25	1022 x 546 x 25
	in.	32-1/4 x 16-1/2 x 1	32-1/4x21-1/4x1	40-1/4x21-1/4 x1
<b>Economizer Dampers (Horizontal)</b> - Mechanically linked recirculated air and outdoor air dampers, plug-in connections to unit, nylon bearings, stainless steel seals (outdoor dampers), 24 volt fully modulating spring return damper motor, adjustable minimum damper position switch, mixed air controller, solid-state adjustable outdoor air enthalpy control, 0 to 100% outdoor air adjustable, galvanized steel cabinet, flanged air openings on return air section, powdered enamel paint finish, fully insulated. NOTE - Economizer Damper Hood is required and must be ordered separately (see below). Also requires optional Horizontal Supply and Return Air Kit for duct connection		EMDH16M-09 Dampers 54 kg (120 lbs.)	EMDH16M-12 Dampers 62 kg (135 lbs.)	EMDH16M-15 Dampers 85 kg (187 lbs.)
<b>Economizer Damper Hood (Horizontal)</b> - Required with EMD16M economizer dampers (see above). Must be ordered separately. Includes two cleanable aluminum mesh frame filters.	Order No.	<b>68G80</b>		<b>68G77</b>
	Number and Size of Filters - mm (in.)	(2) 406 x 635 x 25 (16 x 25 x 1)		(2) 508 x 635 x 25 (20 x 25 x 1)
<b>Economizer Gravity Exhaust Dampers (Horizontal)</b> - For use with EMDH16 horizontal economizer damper sections, two neoprene coated fiberglass dampers furnished, rainhoods furnished, bird screen furnished	Order Number - Net Weight	GED16-09/12 - 5 lbs. (2 kg)		
	Net Face Area	0.04 m <sup>2</sup> (0.43 ft <sup>2</sup> )		
<b>Electric Heat</b> - Factory or field installed, helix wound nichrome elements, time delay for element staging, individual element limit controls, may be two-stage controlled, requires optional Unit Fuse Block		ECH16-82/95 10-15-20-30-40 kW	ECH16-135 15-20-30-40-50 kW	
<b>Unit Fuse Block</b> - Required for electric heat installation, wiring harness and mounting screws furnished	<b>50L23</b> 20 amp	<b>50L24</b> 25 amp	<b>50L26</b> 35 amp	
<b>Hail Guards</b> - Heavy duty field installed coil guard protects coils from damage. Not used with Coil Guards.	<b>60L33</b>		<b>60L34</b>	
<b>Horizontal Supply and Return Air Kit</b> - Provides duct connection to unit, flanges furnished, hardware furnished, two filler panels furnished for unused air openings, filter access panel furnished	Model Number	LB-55756BA ( <b>34G71</b> )	LB-55756BB ( <b>35G42</b> )	LB-55756BC ( <b>51G27</b> )
	Net Weight	14 kg (30 lbs.)	16 kg (35 lbs.)	18 kg (39 lbs.)
<b>Low Ambient Controls</b> - Allows unit operation down to -17.7°C (0°F)	LB-57113BC ( <b>24H77</b> )	LB-57113BG ( <b>15J80</b> )	LB-57113BW ( <b>53L84</b> )	
<b>Outdoor Air Damper/Hood Section</b> - Linked mechanical dampers, 0 to 25% (fixed) outdoor air adjustable, one cleanable aluminum mesh frame type filter furnished in hood, section installs on unit for down-flow applications with Outdoor Air Damper Panel Kit (required must be ordered separately - see below). Damper/Hood section field installs in return air duct for horizontal supply and return air applications, panel kit not required for horizontal applications. Minimum mixed air temperature: Electric heat mode - -1°C (30°F) Maximum mixed air temperature: Cooling mode - 32°C (90°F)	Damper/Hood Model Number	OAD16-09/12/15 Outdoor Air Damper/Hood Section (Order Air Damper/Hood and Damper Panel Kit for complete assembly for down-flow applications)		
	Net Weight	19 kg (41 lbs.)	20 kg (43 lbs.)	23 kg (50 lbs.)
	Number and Size of Filters	(1) 406 x 508 x 25 mm (16 x 20 x 1 in.)		
<b>Outdoor Air Damper Panel Kit (Down-Flow Applications)</b> - Required with OAD16 Damper/Hood. Interchangeable unit panel. Model number - Net Weight	OAD16-09 Panel Kit 22 kg (48 lbs.)	OAD16-12 Panel Kit 22 kg (48 lbs.)	OAD16-15 Panel Kit 9 kg (20 lbs.)	
<b>Outdoor Air Damper Motorized Damper Kit</b> - 3 position damper actuator, plug-in connection	<b>35G21</b> - 3 kg (7 lbs.)			
<b>Roof Mounting Frame</b> - Nailer strip furnished, mates to unit, shipped knocked down	RMF16-09 - 49 kg (107 lbs.)		RMF16-12 - 54 kg (119 lbs.)	

## OPTIONAL TEMPERATURE CONTROL SYSTEMS

System and Component Description	Catalog No.
<b>ELECTRO-MECHANICAL THERMOSTAT CONTROL SYSTEM</b>	
<b>Thermostat</b> - Two stage heat & two stage cool with dual temperature levers, subbase choice	13F06
<b>Subbase</b> - Manual system switch (Off-Heat-Auto-Cool), fan switch (Auto-On)	13F17
<b>Subbase</b> - Non-switching	13F16
<b>Night Setback Operation</b> - Order components below	-
<b>Heating Thermostat</b> - Single stage heat	13F12
<b>Subbase</b> - Non-switching	13F16
<b>Night Kit</b> - Required if economizer is not used, contains plug-in relay, overrides operation of day thermostat	39G74
<b>Time Clock</b> - 7 day operation, indicates day and night periods, 2 hour increments, battery back-up	See Price Book for Selection
<b>Time Clock</b> - 24 hour night setback operation, 15 minute increments, battery back-up	See Price Book for Selection
<b>Cycle Control (Required)</b> - provides timed-on and off function, prevents compressor short cycling	45L54
<b>T7300 THERMOSTAT CONTROL SYSTEM</b>	
<b>Thermostat</b> - Programmable, internal or optional remote temperature sensing (sensor required), touch sensitive keyboard, automatic switching, °F or °C readout, no anticipator, droop/no droop selection, indicator LED's, hour/day programming, override capabilities, time and operational mode readout, stage status indicators, battery back-up, subbase choice	37L54
<b>Subbase</b> - Selectable staging up to two stage heat & two stage cool, manual system switch (Heat-Off-Auto-Cool), fan switch (Auto-On), indicator LED's, auxiliary relay output for economizer operation	37L53
<b>Subbase</b> - Selectable staging up to three stage heat & two stage cool, manual system switch (Auto-Cool-Off-Heat-Emergency Heat) (heat pump only), fan switch (Auto-On), indicator LED's, auxiliary relay output for economizer operation	37L55
<b>Sensor</b> - Room temperature	58C92
<b>Sensor</b> - Room temperature with 3 hour override and setpoint adjustment	86G67
<b>Sensor</b> - Return air temperature	27C40

## OPTIONAL TEMPERATURE CONTROL SYSTEMS FLOWCHARTS

### ELECTRO-MECHANICAL THERMOSTAT

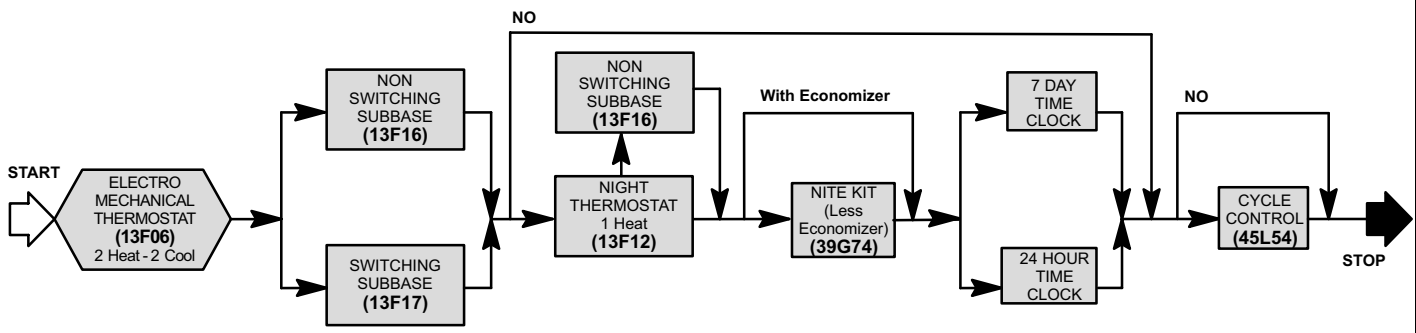

### HONEYWELL T7300 THERMOSTAT

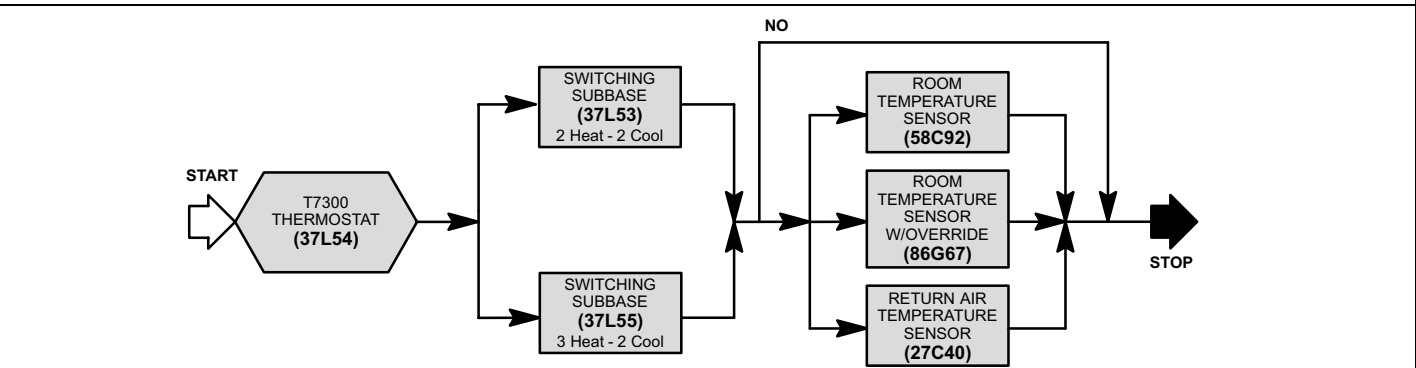

# FIELD WIRING

## ELECTRO-MECHANICAL THERMOSTAT CONTROL SYSTEM

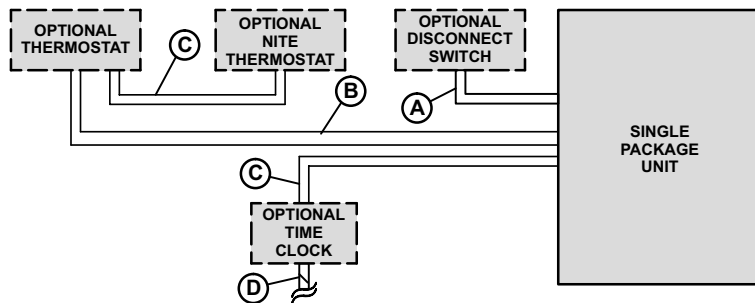

- A - Three phase with neutral (See Electrical Data Table)
- B - Six wire 24V
- C - Two wire 24V
- D - Two wire 24V

- Field wiring not furnished -

NOTE - All wiring must conform to NEC or CEC and local electrical codes.

## T7300 THERMOSTAT CONTROL SYSTEM

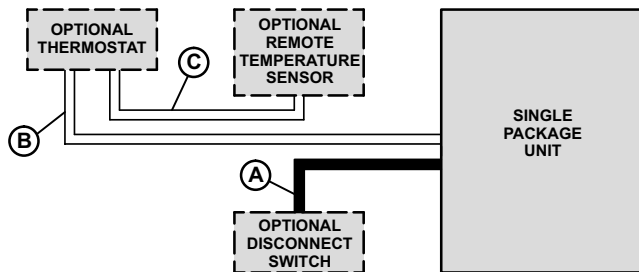

- A - Three phase with neutral (See Electrical Data Table)
- B - Nine wire 24V
- C - Two wire 24V
- Seven wire 24V (T7300 Room Sensor with override)

- Field wiring not furnished -

NOTE - All wiring must conform to local electrical codes.

## SPECIFICATIONS

Model Number		CHA16-072	CHA16-090	CHA16-120	CHA16-150	
Cooling Ratings	Gross cooling capacity - kW (kcal) (Btuh)	19.9 (20 300) (67 800)	24.9 (25 500) (84 900)	32.9 (33 700) (112 300)	39.9 (40 900) (136 200)	
	★Net cooling capacity - kW (kcal) (Btuh)	19.0 (19 500) (65 000)	23.4 (24 000) (80 000)	31.0 (31 800) (106 000)	37.5 (38 800) (128 000)	
	Total power input - kW	7.2	8.8	11.7	14.2	
	Coefficient of Performance - Output/Input	2.6	2.6	2.6	2.6	
	★Energy Efficiency Ratio (Btuh/Watts)	9.0	9.0	9.0	9.0	
	★Integrated Part Load Value	----	----	9.2	8.5	
*Sound Rating Number (db)	86	86	82	88		
Refrigerant Charge (HCFC-22)	Circuit 1	4.31 kg (9 lbs. 8 oz.)	2.72 kg (6 lbs. 0 oz.)	3.4 kg (7 lbs. 8 oz.)	3.9 kg (8 lbs. 8 oz.)	
	Circuit 2	----	2.72 kg (6 lbs. 0 oz.)	3.4 kg (7 lbs. 8 oz.)	3.9 kg (8 lbs. 8 oz.)	
Evaporator Blower and Drive Selection	Blower wheel nominal diameter x width - mm (in.)	305 x 305 (12 x 12)		381 x 381 (15 x 15)		
	Factory Installed □ Drives	Nominal motor output - kW (hp)	1.5 (2)		1.5 (2)	2.2 (3)
		Voltage and phase	380/420v-50hz-3ph with neutral			
		Rev/min range	870 - 1165	870 - 1165	700 - 930	765 - 1020
Evaporator Coil	Net face area - m <sup>2</sup> (ft. <sup>2</sup> )	0.72 (7.75)		0.88 (9.46)	1.11 (11.92)	
	Tube outside diameter - mm (in.) - Number of rows	9.5 (3/8) - 3				
	Fins per m (inch)	551 (14)				
	Expansion device type	Thermostatic Expansion Valve				
	Drain connection size male pipe thread - mm (in.)	25.4 (1) polyvinyl chloride				
Condenser Coil	Net face area - m <sup>2</sup> (ft. <sup>2</sup> )	1.21 (13.0)	1.46 (15.67)	2.23 (24.0)		
	Tube outside diameter - mm (in.) - Number of rows	9.5 (3/8) - 2				
	Fins per m (inch)	787 (20)				
Condenser Fan	Diameter - mm (in.) - Number of blades	(1) 610 (24) - 3	(1) 610 (24) - 4	(2) 508 (20) - 4	(2) 610 (24) - 3	
	Air volume - L/s (cfm)	1630 (3450)	2020 (4275)	2500 (5300)	3305 (7000)	
	Motor output - W (hp)	(1) 249 (1/3)	(1) 560 (3/4)	(2) 249 (1/3)	(2) 373 (1/2)	
	Motor rev/min	896				
	Total motor input - W	340	500		950	
Filters (furnished)	Type of filter	Disposable, pleated, commercial grade				
	Number and size - mm (in.)	(4) 406 x 508 x 51 (16 x 20 x 2)		(2) 406 x 635 x 51 (16 x 25 x 2) & (2) 406 x 508 x 51 (16 x 20 x 2)	(2) 508 x 635 x 51 (20 x 25 x 2) & (2) 508 x 508 x 51 (20 x 20 x 2)	
Net weight of basic unit - kg (lbs.)		299 (660)	367 (810)	454 (1000)	499 (1100)	
Shipping weight of basic unit - kg (lbs.) (1 Package)		363 (800)	451 (995)	538 (1185)	583 (1285)	

\*Sound Rating Number in accordance with test conditions included in ARI Standard 270-96.

★Rated in accordance with ARI Standard 210/24-86 while operating at rated voltage and air volumes;

Cooling Ratings: 35°C (95°F) outdoor air temperature and 27°C (80°F) db/19°C (67°F) wb entering evaporator air; minimum external duct static pressure.

†Integrated Part Load Value rated at 27°C (80°F) outdoor air temperature.

NOTE - Net capacity includes evaporator blower motor heat deduction. Gross capacity does not include evaporator blower motor heat deduction.

ELECTRICAL DATA					
Model Number		CHA16-072	CHA16-090	CHA16-120	CHA16-150
Line voltage data - 50hz - 3 phase with neutral		380/420v			
Voltage range (minimum - maximum)		342-462V			
Compressors	Number of compressors	1	2	2	2
	Rated load amps - each (total)	9.1	6.7 (13.4)	8.8 (17.7)	9.1 (18.2)
	Locked rotor amps - each (total)	70 (70)	46 (92)	63 (126)	70 (140)
Condenser Fan Motor(s)	Number of fan motors	1	1	2	2
	Full load amps - each (total)	1.3 (1.3)	1.9 (1.9)	1.3 (2.6)	1.5 (3)
	Locked rotor amps - each (total)	2.4 (2.4)	3.7 (3.7)	2.4 (4.8)	3 (6)
Evaporator Blower Motor	Motor Output - kW (hp)	1.5 (2)	1.5 (2)	1.5 (2)	2.2 (3)
	Full load amps	3	3	3	4.7
	Locked rotor amps	22.1	22.1	22.1	27

†Refer to local electrical codes to determine wire, fuse and disconnect size requirements. Use wires suitable for at least 75°C (167°F). Service factor = 1.15

ELECTRIC HEAT DATA - FUSE BLOCK REQUIRED													
Electric Heat Model Number & Net Weight	Number of Elements	Volts Input	Total Heating Capacity - 50hz			†Total Unit & Electric Heat Minimum Circuit Ampacity	Electric Heat Model Number & Net Weight	Number of Elements	Volts Input	Total Heating Capacity - 50hz			†Total Unit & Electric Heat Minimum Circuit Ampacity
			kW	kcal	Btuh					kW	kcal	Btuh	
<b>CHA16-072 MODEL</b>						<b>CHA16-120 MODEL</b>							
ECH16-82/95-10 (61H73) 17 kg (38 lbs.)	1	380	6.3	5390	21 400	17	ECH16-135-15 (72G26) 38 lbs. (17 kg)	1	380	9.4	8090	32 100	26
		400	6.9	5970	23 700				400	10.4	8970	35 600	
		420	7.7	6575	26 100				420	11.5	9880	39 200	
ECH16-82/95-15 (61H74) 17 kg (38 lbs.)	1	380	9.4	8090	32 100	24	ECH16-135-20 (72G27) 42 lbs. (19 kg)	1	380	12.5	10 800	42 800	31
		400	10.4	8970	35 600				400	13.9	11 900	47 400	
		420	11.5	9880	39 200				420	15.3	13 200	52 300	
ECH16-82/95-20 (61H75) 19 kg (42 lbs.)	1	380	12.5	10 800	42 800	31	ECH16-135-30 (72G28) 42 lbs. (19 kg)	1	380	18.8	16 200	64 200	44
		400	13.9	11 900	47 400				400	20.8	17 900	71 100	
		420	15.3	13 200	52 300				420	23.0	19 800	78 400	
ECH16-82/95-30 (61H76) 19 kg (42 lbs.)	1	380	18.8	16 200	64 200	44	ECH16-135-40 (72G29) 53 lbs. (24 kg)	1	380	26.1	21 500	85 500	57
		400	20.8	17 900	71 100				400	27.8	24 100	95 800	
		420	23.0	19 800	78 400				420	30.6	26 300	104 500	
ECH16-82/95-40 (61H77) 24 kg (53 lbs.)	1	380	26.1	21 500	85 500	57	ECH16-135-50 (72G30) 58 lbs. (26 kg)	1	380	37.6	32 400	128 400	57
		400	27.8	24 100	95 800				400	41.8	35 900	142 600	
		420	30.6	26 300	104 500				420	45.9	39 500	156 800	
<b>CHA16-090 MODEL</b>						<b>CHA16-150 MODEL</b>							
ECH16-82/95-10 (61H73) 17 kg (38 lbs.)	1	380	6.3	5390	21 400	20	ECH16-135-15 (72G26) 38 lbs. (17 kg)	1	380	9.4	8090	32 100	29
		400	6.9	5970	23 700				400	10.4	8970	35 600	
		420	7.7	6575	26 100				420	11.5	9880	39 200	
ECH16-82/95-15 (61H74) 17 kg (38 lbs.)	1	380	9.4	8090	32 100	24	ECH16-135-20 (72G27) 42 lbs. (19 kg)	1	380	12.5	10 800	42 800	33
		400	10.4	8970	35 600				400	13.9	11 900	47 400	
		420	11.5	9880	39 200				420	15.3	13 200	52 300	
ECH16-82/95-20 (61H75) 19 kg (42 lbs.)	1	380	12.5	10 800	42 800	31	ECH16-135-30 (72G28) 42 lbs. (19 kg)	1	380	18.8	16 200	64 200	46
		400	13.9	11 900	47 400				400	20.8	17 900	71 100	
		420	15.3	13 200	52 300				420	23.0	19 800	78 400	
ECH16-82/95-30 (61H76) 19 kg (42 lbs.)	1	380	18.8	16 200	64 200	44	ECH16-135-40 (72G29) 53 lbs. (24 kg)	1	380	26.1	21 500	85 500	59
		400	20.8	17 900	71 100				400	27.8	24 100	95 800	
		420	23.0	19 800	78 400				420	30.6	26 300	104 500	
ECH16-82/95-40 (61H77) 24 kg (53 lbs.)	1	380	26.1	21 500	85 500	57	ECH16-135-50 (72G30) 58 lbs. (26 kg)	1	380	37.6	32 400	128 400	59
		400	27.8	24 100	95 800				400	41.8	35 900	142 600	
		420	30.6	26 300	104 500				420	45.9	39 500	156 800	

□ May be used with two stage control.

□ May be used with two stage control.

# COOLING RATINGS

NOTE - For Temperatures and Capacities not shown in tables, see bulletin - Cooling Unit Rating Table Correction Factor Data in Miscellaneous Engineering Data section.

## CHA16-072 - ONE COMPRESSOR OPERATING

Entering Wet Bulb Temperature	Total Air Volume		Outdoor Air Temperature Entering Outdoor Coil																							
			27°C (80°F)						35°C (95°F)						43°C (110°F)						52°C (125°F)					
			Total Cooling Capacity		Comp Motor kW Input	Sensible To Total Ratio (S/T)			Total Cooling Capacity		Comp Motor kW Input	Sensible To Total Ratio (S/T)			Total Cooling Capacity		Comp Motor kW Input	Sensible To Total Ratio (S/T)			Total Cooling Capacity		Comp Motor kW Input	Sensible To Total Ratio (S/T)		
						Dry Bulb						Dry Bulb						Dry Bulb						Dry Bulb		
m³/s	cfm	kW	kBtuh	24°C 75°F	27°C 80°F	29°C 85°F	kW	kBtuh	Input	24°C 75°F	27°C 80°F	29°C 85°F	kW	kBtuh	Input	24°C 75°F	27°C 80°F	29°C 85°F	kW	kBtuh	Input	24°C 75°F	27°C 80°F	29°C 85°F		
17°C (63°F)	.89	1900	19.2	65.5	4.41	.73	.87	.98	18.2	62.2	5.22	.75	.89	1.00	17.1	58.5	6.19	.77	.92	1.00	15.9	54.4	7.37	.80	.95	1.00
	1.13	2400	19.9	68.0	4.47	.79	.94	1.00	18.9	64.5	5.28	.81	.96	1.00	17.8	60.8	6.26	.84	.99	1.00	16.7	56.9	7.45	.87	1.00	1.00
	1.37	2900	20.6	70.2	4.53	.84	.99	1.00	19.6	66.8	5.34	.87	1.00	1.00	18.5	63.2	6.34	.90	1.00	1.00	17.3	59.2	7.53	.93	1.00	1.00
19°C (67°F)	.89	1900	20.3	69.4	4.51	.57	.71	.84	19.3	65.8	5.32	.58	.72	.86	18.1	61.9	6.30	.59	.74	.89	16.8	57.4	7.49	.61	.77	.92
	1.13	2400	21.0	71.5	4.56	.61	.77	.92	19.9	67.8	5.37	.62	.79	.94	18.6	63.6	6.36	.63	.81	.97	17.3	59.1	7.54	.65	.85	.99
	1.37	2900	21.4	73.0	4.61	.64	.83	.97	20.3	69.2	5.42	.66	.85	.99	19.0	64.9	6.40	.68	.88	1.00	17.7	60.3	7.59	.70	.91	1.00
22°C (71°F)	.89	1900	21.6	73.8	4.62	.43	.56	.68	20.5	70.0	5.44	.43	.57	.70	19.3	65.9	6.43	.43	.58	.72	17.9	61.2	7.63	.44	.59	.75
	1.13	2400	22.2	75.9	4.68	.44	.59	.75	21.1	71.9	5.50	.45	.61	.77	19.8	67.5	6.50	.45	.62	.79	18.4	62.7	7.68	.46	.64	.83
	1.37	2900	22.7	77.3	4.72	.45	.63	.81	21.4	73.1	5.54	.46	.65	.83	20.1	68.6	6.53	.47	.67	.86	18.6	63.6	7.72	.48	.69	.89

## CHA16-090 — ONE COMPRESSOR OPERATING

Entering Wet Bulb Temperature	Total Air Volume		Outdoor Air Temperature Entering Outdoor Coil																							
			18°C (65°F)						24°C (75°F)						29°C (85°F)						35°C (95°F)					
			Total Cooling Capacity		Comp Motor kW Input	Sensible To Total Ratio (S/T)			Total Cooling Capacity		Comp Motor kW Input	Sensible To Total Ratio (S/T)			Total Cooling Capacity		Comp Motor kW Input	Sensible To Total Ratio (S/T)			Total Cooling Capacity		Comp Motor kW Input	Sensible To Total Ratio (S/T)		
						Dry Bulb						Dry Bulb						Dry Bulb						Dry Bulb		
m³/s	cfm	kW	kBtuh	24°C 75°F	27°C 80°F	29°C 85°F	kW	kBtuh	Input	24°C 75°F	27°C 80°F	29°C 85°F	kW	kBtuh	Input	24°C 75°F	27°C 80°F	29°C 85°F	kW	kBtuh	Input	24°C 75°F	27°C 80°F	29°C 85°F		
17°C (63°F)	1.18	2500	12.5	42.7	2.43	.71	.85	.96	12.1	41.4	2.70	.72	.86	.98	11.8	40.1	3.01	.73	.87	.99	11.3	38.7	3.37	.74	.89	.99
	1.41	3000	12.9	43.9	2.46	.75	.90	1.00	12.5	42.6	2.73	.76	.91	1.00	12.1	41.2	3.05	.78	.93	1.00	11.7	39.8	3.41	.79	.95	1.00
	1.65	3500	13.2	45.0	2.49	.79	.95	1.00	12.8	43.6	2.76	.81	.96	1.00	12.4	42.3	3.07	.82	.97	1.00	12.0	40.8	3.43	.83	.98	1.00
19°C (67°F)	1.18	2500	13.2	45.2	2.49	.56	.69	.82	12.9	43.9	2.76	.56	.69	.83	12.4	42.4	3.07	.57	.71	.84	12.0	40.9	3.43	.58	.72	.86
	1.41	3000	13.6	46.3	2.52	.58	.73	.87	13.2	44.9	2.79	.59	.74	.89	12.7	43.4	3.10	.60	.75	.90	12.3	41.8	3.46	.60	.77	.92
	1.65	3500	13.8	47.1	2.53	.61	.77	.92	13.4	45.6	2.81	.61	.79	.93	12.9	44.1	3.13	.62	.80	.95	12.5	42.5	3.49	.63	.81	.97
22°C (71°F)	1.18	2500	14.1	48.0	2.56	.42	.54	.66	13.7	46.6	2.84	.42	.55	.67	13.2	45.0	3.15	.42	.55	.68	12.7	43.4	3.51	.43	.56	.69
	1.41	3000	14.4	49.1	2.59	.43	.57	.71	13.9	47.5	2.87	.43	.58	.72	13.5	45.9	3.18	.43	.58	.73	13.0	44.2	3.54	.44	.59	.74
	1.65	3500	14.6	49.8	2.61	.44	.59	.75	14.2	48.3	2.89	.44	.60	.76	13.7	46.6	3.20	.44	.61	.78	13.2	44.9	3.57	.45	.62	.80

## CHA16-090 - ALL COMPRESSORS OPERATING

Entering Wet Bulb Temperature	Total Air Volume		Outdoor Air Temperature Entering Outdoor Coil																							
			27°C (80°F)						35°C (95°F)						43°C (110°F)						52°C (125°F)					
			Total Cooling Capacity		Comp Motor kW Input	Sensible To Total Ratio (S/T)			Total Cooling Capacity		Comp Motor kW Input	Sensible To Total Ratio (S/T)			Total Cooling Capacity		Comp Motor kW Input	Sensible To Total Ratio (S/T)			Total Cooling Capacity		Comp Motor kW Input	Sensible To Total Ratio (S/T)		
						Dry Bulb						Dry Bulb						Dry Bulb						Dry Bulb		
m³/s	cfm	kW	kBtuh	24°C 75°F	27°C 80°F	29°C 85°F	kW	kBtuh	Input	24°C 75°F	27°C 80°F	29°C 85°F	kW	kBtuh	Input	24°C 75°F	27°C 80°F	29°C 85°F	kW	kBtuh	Input	24°C 75°F	27°C 80°F	29°C 85°F		
17°C (63°F)	1.18	2500	24.3	83.0	5.73	.74	.88	.99	23.1	78.7	6.77	.76	.90	1.00	21.7	74.0	8.06	.78	.93	1.00	20.2	68.9	9.66	.81	.96	1.00
	1.41	3000	25.0	85.3	5.79	.78	.94	1.00	23.7	81.0	6.84	.80	.96	1.00	22.3	76.2	8.13	.83	.98	1.00	20.8	71.1	9.75	.86	1.00	1.00
	1.65	3500	25.6	87.4	5.84	.83	.98	1.00	24.4	83.1	6.89	.85	.99	1.00	23.0	78.4	8.21	.88	1.00	1.00	21.5	73.4	9.84	.91	1.00	1.00
19°C (67°F)	1.18	2500	25.7	87.7	5.84	.58	.71	.85	24.4	83.1	6.89	.58	.73	.87	22.8	77.9	8.20	.60	.75	.90	21.2	72.3	9.81	.61	.78	.93
	1.41	3000	26.3	89.6	5.90	.60	.76	.91	24.9	84.9	6.95	.61	.78	.93	23.3	79.6	8.25	.63	.81	.96	21.6	73.7	9.88	.65	.84	.99
	1.65	3500	26.7	91.1	5.94	.63	.81	.96	25.3	86.2	7.00	.64	.83	.98	23.7	80.8	8.30	.66	.86	.99	22.0	74.9	9.93	.69	.89	1.00
22°C (71°F)	1.18	2500	27.3	93.1	6.00	.43	.56	.69	25.8	88.1	7.05	.43	.57	.71	24.2	82.7	8.38	.44	.58	.73	22.5	76.7	9.99	.44	.60	.76
	1.41	3000	27.8	94.9	6.06	.44	.59	.74	26.3	89.8	7.11	.44	.60	.76	24.7	84.2	8.43	.45	.62	.79	22.8	77.9	10.06	.46	.64	.82
	1.65	3500	28.2	96.2	6.10	.45	.62	.79	26.7	91.1	7.16	.45	.63	.81	25.0	85.3	8.47	.46	.65	.84	23.1	78.9	10.12	.47	.68	.88





**BLOWER DATA****CHA16-072/090 BLOWER PERFORMANCE****BOLD DATA INDICATES FIELD FURNISHED DRIVE**

Air Volume cfm (m³/s)	STATIC PRESSURE EXTERNAL TO UNIT — Inches Water Gauge (Pa)																									
	.20(50)		.30(75)		.40(100)		.50(125)		.60(150)		.70(175)		.80(200)		.90(225)		1.00(250)		1.10(275)		1.20(300)		1.30(325)			
	Rev/ Min	HP (kW)	Rev/ Min	HP (kW)	Rev/ Min	HP (kW)	Rev/ Min	HP (kW)	Rev/ Min	HP (kW)	Rev/ Min	HP (kW)	Rev/ Min	HP (kW)	Rev/ Min	HP (kW)	Rev/ Min	HP (kW)	Rev/ Min	HP (kW)	Rev/ Min	HP (kW)	Rev/ Min	HP (kW)	Rev/ Min	HP (kW)
2000 (0.95)	<b>585</b>	<b>0.35</b>	<b>630</b>	<b>0.40</b>	<b>680</b>	<b>0.45</b>	<b>725</b>	<b>0.50</b>	<b>775</b>	<b>0.60</b>	<b>820</b>	<b>0.65</b>	865	0.75	910	0.80	955	0.90	1000	0.95	1045	1.05	1090	1.15	1090	1.15
2200 (1.05)	<b>625</b>	<b>0.45</b>	<b>670</b>	<b>0.50</b>	<b>710</b>	<b>0.55</b>	<b>755</b>	<b>0.65</b>	<b>795</b>	<b>0.70</b>	<b>840</b>	<b>0.75</b>	880	0.85	925	0.90	965	1.00	1005	1.05	1050	1.15	1090	1.25	1090	1.25
2400 (1.15)	<b>665</b>	<b>0.55</b>	<b>705</b>	<b>0.60</b>	<b>745</b>	<b>0.70</b>	<b>785</b>	<b>0.75</b>	<b>825</b>	<b>0.80</b>	<b>865</b>	<b>0.90</b>	905	0.95	940	1.05	980	1.10	1020	1.20	1055	1.30	1095	1.40	1095	1.40
2600 (1.25)	<b>710</b>	<b>0.70</b>	<b>745</b>	<b>0.75</b>	<b>780</b>	<b>0.80</b>	<b>820</b>	<b>0.90</b>	855	0.95	890	1.05	930	1.10	965	1.20	1000	1.30	1035	1.35	1070	1.45	1105	1.55	1105	1.55
2800 (1.30)	<b>750</b>	<b>0.85</b>	<b>785</b>	<b>0.90</b>	<b>820</b>	<b>0.95</b>	855	1.05	890	1.10	925	1.20	955	1.30	990	1.35	1025	1.45	1055	1.55	1090	1.65	1125	1.75	1125	1.75
3000 (1.40)	<b>795</b>	<b>1.00</b>	<b>830</b>	<b>1.05</b>	860	1.15	890	1.20	925	1.30	955	1.40	985	1.45	1020	1.55	1050	1.65	1080	1.75	1115	1.85	<b>1145</b>	<b>1.95</b>	<b>1145</b>	<b>1.95</b>
3200 (1.50)	<b>840</b>	<b>1.20</b>	870	1.25	900	1.35	930	1.40	960	1.50	990	1.60	1020	1.70	1050	1.75	1080	1.85	1110	1.95	<b>1140</b>	<b>2.05</b>	<b>1170</b>	<b>2.15</b>	<b>1170</b>	<b>2.15</b>
3400 (1.60)	885	1.40	915	1.50	940	1.55	970	1.65	1000	1.75	1025	1.80	1055	1.90	1085	2.00	1110	2.10	<b>1140</b>	<b>2.20</b>	<b>1165</b>	<b>2.30</b>	<b>1195</b>	<b>2.40</b>	<b>1195</b>	<b>2.40</b>
3600 (1.70)	930	1.65	960	1.75	985	1.80	1010	1.90	1040	2.00	1065	2.10	1090	2.20	1120	2.30	<b>1145</b>	<b>2.40</b>	<b>1170</b>	<b>2.50</b>	<b>1200</b>	<b>2.60</b>	<b>1225</b>	<b>2.70</b>	<b>1225</b>	<b>2.70</b>
3800 (1.80)	975	1.90	1005	2.00	1030	2.10	1055	2.20	1080	2.30	<b>1105</b>	<b>2.40</b>	<b>1130</b>	<b>2.50</b>	<b>1155</b>	<b>2.60</b>	<b>1180</b>	<b>2.70</b>	<b>1205</b>	<b>2.80</b>	<b>1230</b>	<b>2.90</b>	<b>1255</b>	<b>3.00</b>	<b>1255</b>	<b>3.00</b>

NOTE — All data is measured external to the unit with dry coil and with the air filters in place. See Page 11 for Accessory Air Resistance data.

**CHA16-120 BLOWER PERFORMANCE****BOLD DATA INDICATES FIELD FURNISHED DRIVE**

Air Volume cfm (m³/s)	STATIC PRESSURE EXTERNAL TO UNIT — Inches Water Gauge (Pa)																													
	.20 (50)		.30 (75)		.40 (100)		.50 (125)		.60 (150)		.70 (175)		.80 (200)		.90 (225)		1.00 (250)		1.10 (275)		1.20 (300)		1.30 (325)		1.40 (350)		1.50 (375)			
	Rev/ Min	HP (kW)	Rev/ Min	HP (kW)	Rev/ Min	HP (kW)	Rev/ Min	HP (kW)	Rev/ Min	HP (kW)	Rev/ Min	HP (kW)	Rev/ Min	HP (kW)	Rev/ Min	HP (kW)	Rev/ Min	HP (kW)	Rev/ Min	HP (kW)	Rev/ Min	HP (kW)	Rev/ Min	HP (kW)	Rev/ Min	HP (kW)	Rev/ Min	HP (kW)	Rev/ Min	HP (kW)
3000 (1.40)	<b>510</b>	<b>0.50</b>	<b>550</b>	<b>0.60</b>	<b>585</b>	<b>0.65</b>	<b>620</b>	<b>0.70</b>	<b>655</b>	<b>0.80</b>	<b>690</b>	<b>0.85</b>	<b>720</b>	<b>0.95</b>	750	1.00	780	1.05	810	1.15	840	1.20	870	1.30	895	1.40	925	1.45	925	1.45
3200 (1.50)	<b>535</b>	<b>0.60</b>	<b>570</b>	<b>0.70</b>	<b>605</b>	<b>0.75</b>	<b>640</b>	<b>0.80</b>	<b>670</b>	<b>0.90</b>	<b>705</b>	<b>0.95</b>	735	1.05	765	1.10	795	1.20	825	1.30	850	1.35	880	1.45	905	1.50	930	1.60	930	1.60
3400 (1.60)	<b>560</b>	<b>0.70</b>	<b>595</b>	<b>0.80</b>	<b>630</b>	<b>0.85</b>	<b>660</b>	<b>0.95</b>	<b>690</b>	<b>1.00</b>	<b>720</b>	<b>1.10</b>	750	1.15	780	1.25	810	1.35	835	1.40	865	1.50	890	1.60	915	1.65	940	1.75	940	1.75
3600 (1.70)	<b>585</b>	<b>0.85</b>	<b>620</b>	<b>0.90</b>	<b>650</b>	<b>1.00</b>	<b>680</b>	<b>1.05</b>	<b>710</b>	<b>1.15</b>	740	1.25	770	1.30	795	1.40	825	1.50	850	1.55	875	1.65	900	1.70	925	1.80	950	1.90	950	1.90
3800 (1.80)	<b>610</b>	<b>0.95</b>	<b>645</b>	<b>1.05</b>	<b>670</b>	<b>1.10</b>	<b>700</b>	<b>1.20</b>	<b>730</b>	<b>1.30</b>	760	1.40	785	1.45	815	1.55	840	1.65	865	1.70	890	1.80	915	1.90	940	2.00	965	2.10	965	2.10
4000 (1.90)	<b>640</b>	<b>1.10</b>	<b>665</b>	<b>1.20</b>	<b>695</b>	<b>1.30</b>	<b>725</b>	<b>1.35</b>	750	1.45	780	1.55	805	1.65	830	1.70	855	1.80	880	1.90	905	2.00	930	2.10	955	2.20	980	2.30	980	2.30
4200 (2.00)	<b>665</b>	<b>1.30</b>	<b>690</b>	<b>1.35</b>	<b>720</b>	<b>1.45</b>	745	1.55	775	1.65	800	1.70	825	1.80	850	1.90	875	2.00	900	2.10	920	2.20	945	2.30	970	2.40	990	2.45	990	2.45
4400 (2.10)	<b>690</b>	<b>1.45</b>	<b>715</b>	<b>1.55</b>	745	1.65	770	1.70	795	1.80	820	1.90	845	2.00	870	2.10	895	2.20	915	2.30	940	2.40	960	2.50	985	2.60	1005	2.70	1005	2.70
4600 (2.15)	<b>715</b>	<b>1.65</b>	745	1.75	770	1.85	795	1.95	820	2.05	840	2.10	865	2.20	890	2.30	910	2.40	935	2.50	955	2.60	980	2.75	1000	2.80	<b>1025</b>	<b>2.95</b>	<b>1025</b>	<b>2.95</b>
4800 (2.25)	745	1.85	770	1.95	795	2.05	815	2.15	840	2.25	865	2.35	885	2.45	910	2.55	930	2.65	955	2.75	975	2.85	1000	3.00	<b>1020</b>	<b>3.10</b>	<b>1040</b>	<b>3.20</b>	<b>1040</b>	<b>3.20</b>
5000 (2.35)	770	2.05	795	2.15	820	2.30	840	2.35	865	2.50	885	2.60	910	2.70	930	2.80	955	2.90	975	3.00	995	3.10	1015	3.25	<b>1035</b>	<b>3.35</b>	<b>1055</b>	<b>3.45</b>	<b>1055</b>	<b>3.45</b>
5200 (2.45)	800	2.30	820	2.40	845	2.55	865	2.60	890	2.75	910	2.85	930	2.95	955	3.10	975	3.20	995	3.30	1015	3.40	---	---	---	---	---	---	---	---

NOTE — All data is measured external to the unit with dry coil and with the air filters in place. See Page 11 for Accessory Air Resistance data.

# BLOWER DATA

## CHA16-150 BLOWER PERFORMANCE

**BOLD DATA INDICATES FIELD FURNISHED DRIVE**  
**SHADED DATA INDICATES FIELD FURNISHED MOTOR**

Air Volume cfm (m <sup>3</sup> /s)	STATIC PRESSURE EXTERNAL TO UNIT — Inches Water Gauge (Pa)																													
	.20 (50)		.30 (75)		.40 (100)		.50 (125)		.60 (150)		.70 (175)		.80 (200)		.90 (225)		1.00 (250)		1.10 (275)		1.20 (300)		1.30 (325)		1.40 (350)		1.50 (375)		1.60 (400)	
	Rev/Min	HP (kW)	Rev/Min	HP (kW)	Rev/Min	HP (kW)	Rev/Min	HP (kW)	Rev/Min	HP (kW)	Rev/Min	HP (kW)	Rev/Min	HP (kW)	Rev/Min	HP (kW)	Rev/Min	HP (kW)	Rev/Min	HP (kW)	Rev/Min	HP (kW)	Rev/Min	HP (kW)	Rev/Min	HP (kW)	Rev/Min	HP (kW)	Rev/Min	HP (kW)
3800 (1.80)	<b>580</b>	<b>0.90</b>	<b>615</b>	<b>1.00</b>	<b>650</b>	<b>1.10</b>	<b>680</b>	<b>1.20</b>	<b>710</b>	<b>1.30</b>	740	1.35	765	1.45	795	1.55	820	1.65	845	1.70	870	1.80	895	1.90	920	2.00	940	2.05	965	2.15
3900 (1.85)	<b>590</b>	<b>1.00</b>	<b>625</b>	<b>1.05</b>	<b>660</b>	<b>1.15</b>	<b>690</b>	<b>1.25</b>	<b>720</b>	<b>1.35</b>	750	1.45	775	1.55	805	1.65	830	1.75	855	1.80	880	1.90	900	2.00	925	2.10	950	2.20	970	2.25
4000 (1.90)	<b>605</b>	<b>1.05</b>	<b>640</b>	<b>1.15</b>	<b>670</b>	<b>1.25</b>	<b>700</b>	<b>1.35</b>	<b>730</b>	<b>1.45</b>	760	1.55	785	1.60	810	1.70	835	1.80	860	1.90	885	2.00	910	2.10	935	2.20	955	2.25	980	2.35
4100 (1.95)	<b>615</b>	<b>1.10</b>	<b>650</b>	<b>1.20</b>	<b>680</b>	<b>1.30</b>	<b>710</b>	<b>1.40</b>	740	1.50	765	1.60	795	1.70	820	1.80	845	1.90	870	2.00	895	2.10	915	2.20	940	2.30	965	2.40	985	2.45
4200 (2.00)	<b>630</b>	<b>1.20</b>	<b>660</b>	<b>1.30</b>	<b>690</b>	<b>1.40</b>	<b>720</b>	<b>1.50</b>	750	1.60	775	1.70	805	1.80	830	1.90	855	2.00	880	2.10	900	2.20	925	2.30	950	2.40	970	2.50	990	2.55
4300 (2.05)	<b>640</b>	<b>1.25</b>	<b>670</b>	<b>1.35</b>	<b>700</b>	<b>1.50</b>	<b>730</b>	<b>1.60</b>	760	1.70	785	1.80	810	1.90	840	2.00	860	2.10	885	2.20	910	2.30	935	2.40	955	2.50	980	2.60	1000	2.70
4400 (2.10)	<b>650</b>	<b>1.35</b>	<b>685</b>	<b>1.45</b>	<b>710</b>	<b>1.55</b>	740	1.65	770	1.80	795	1.90	820	2.00	845	2.10	870	2.20	895	2.30	920	2.40	940	2.50	965	2.60	985	2.70	1005	2.80
4500 (2.10)	<b>665</b>	<b>1.45</b>	<b>695</b>	<b>1.55</b>	<b>725</b>	<b>1.65</b>	750	1.75	780	1.90	805	2.00	830	2.10	855	2.20	880	2.30	905	2.40	925	2.50	950	2.60	970	2.70	995	2.85	1015	2.95
4600 (2.15)	<b>675</b>	<b>1.50</b>	<b>705</b>	<b>1.65</b>	735	1.75	760	1.85	790	1.95	815	2.10	840	2.20	865	2.30	890	2.40	910	2.50	935	2.60	960	2.75	980	2.85	1000	2.95	<b>1020</b>	<b>3.05</b>
4700 (2.20)	<b>690</b>	<b>1.65</b>	<b>715</b>	<b>1.70</b>	745	1.85	775	1.95	800	2.10	825	2.20	850	2.30	875	2.40	900	2.55	920	2.60	945	2.75	965	2.85	990	2.95	1010	3.05	<b>1030</b>	<b>3.20</b>
4800 (2.25)	<b>700</b>	<b>1.70</b>	<b>730</b>	<b>1.85</b>	755	1.95	785	2.05	810	2.20	835	2.30	860	2.40	885	2.55	905	2.60	930	2.75	955	2.85	975	3.00	995	3.10	1015	3.20	<b>1040</b>	<b>3.30</b>
4900 (2.30)	<b>710</b>	<b>1.80</b>	740	1.95	770	2.05	795	2.15	820	2.30	845	2.40	870	2.50	895	2.65	915	2.75	940	2.85	960	3.00	985	3.10	1005	3.20	<b>1025</b>	<b>3.35</b>	<b>1045</b>	<b>3.45</b>
5000 (2.35)	<b>725</b>	<b>1.90</b>	755	2.05	780	2.15	805	2.30	830	2.40	855	2.50	880	2.65	905	2.75	925	2.85	950	3.00	970	3.10	990	3.20	1015	3.35	<b>1035</b>	<b>3.45</b>	<b>1055</b>	<b>3.60</b>
5100 (2.40)	735	2.00	765	2.15	790	2.25	815	2.40	840	2.50	865	2.65	890	2.75	915	2.90	935	3.00	960	3.15	980	3.25	1000	3.35	<b>1020</b>	<b>3.50</b>	<b>1040</b>	<b>3.60</b>	<b>1060</b>	<b>3.70</b>
5200 (2.45)	750	2.15	775	2.25	800	2.40	830	2.55	850	2.65	875	2.75	900	2.90	925	3.05	945	3.15	965	3.25	990	3.40	1010	3.50	<b>1030</b>	<b>3.65</b>	<b>1050</b>	<b>3.75</b>	<b>1070</b>	<b>3.85</b>
5300 (2.50)	760	2.25	790	2.40	815	2.50	840	2.65	865	2.80	885	2.90	910	3.00	935	3.15	955	3.25	975	3.40	1000	3.55	<b>1020</b>	<b>3.65</b>	<b>1040</b>	<b>3.80</b>	<b>1060</b>	<b>3.90</b>	<b>1080</b>	<b>4.05</b>
5400 (2.55)	775	2.40	800	2.50	825	2.65	850	2.75	875	2.90	895	3.00	920	3.15	945	3.30	965	3.40	985	3.55	1010	3.70	<b>1030</b>	<b>3.80</b>	<b>1050</b>	<b>3.95</b>	<b>1070</b>	<b>4.05</b>	<b>1090</b>	<b>4.20</b>
5500 (2.60)	785	2.50	810	2.60	835	2.75	860	2.90	885	3.05	910	3.15	930	3.30	955	3.45	975	3.55	995	3.70	1015	3.80	<b>1035</b>	<b>3.95</b>	<b>1055</b>	<b>4.05</b>	<b>1075</b>	<b>4.20</b>	<b>1095</b>	<b>4.35</b>
5600 (2.65)	800	2.65	825	2.75	850	2.90	875	3.05	895	3.15	920	3.30	940	3.45	965	3.60	985	3.70	1005	3.85	<b>1025</b>	<b>3.95</b>	<b>1045</b>	<b>4.10</b>	<b>1065</b>	<b>4.25</b>	<b>1085</b>	<b>4.35</b>	<b>1105</b>	<b>4.50</b>
5700 (2.70)	810	2.75	835	2.90	860	3.05	885	3.20	905	3.30	930	3.45	950	3.55	975	3.75	995	3.85	1015	4.00	<b>1035</b>	<b>4.10</b>	<b>1055</b>	<b>4.25</b>	<b>1075</b>	<b>4.40</b>	<b>1095</b>	<b>4.55</b>	<b>1115</b>	<b>4.65</b>
5800 (2.75)	825	2.90	850	3.05	870	3.15	895	3.30	920	3.45	940	3.60	960	3.70	985	3.90	1005	4.00	<b>1025</b>	<b>4.15</b>	<b>1045</b>	<b>4.30</b>	<b>1065</b>	<b>4.45</b>	<b>1085</b>	<b>4.55</b>	<b>1105</b>	<b>4.70</b>	<b>1125</b>	<b>4.85</b>
5900 (2.80)	835	3.05	860	3.20	885	3.35	905	3.45	930	3.60	950	3.75	975	3.90	995	4.05	1015	4.20	<b>1035</b>	<b>4.30</b>	<b>1055</b>	<b>4.45</b>	<b>1075</b>	<b>4.60</b>	<b>1095</b>	<b>4.75</b>	<b>1115</b>	<b>4.90</b>	<b>1130</b>	<b>5.00</b>
6000 (2.85)	850	3.20	870	3.30	895	3.45	920	3.65	940	3.75	960	3.90	985	4.05	1005	4.20	<b>1025</b>	<b>4.35</b>	<b>1045</b>	<b>4.50</b>	<b>1065</b>	<b>4.65</b>	<b>1085</b>	<b>4.80</b>	<b>1105</b>	<b>4.95</b>	<b>1125</b>	<b>5.10</b>	<b>1140</b>	<b>5.20</b>

NOTE — All data is measured external to the unit with dry coil and with the air filters in place. See Page 11 for Accessory Air Resistance data.

<b>BLOWER DATA</b>									
<b>ACCESSORY AIR RESISTANCE</b>									
Unit Model Number	Air Volume		Total Resistance - inches water gauge (Pa)						
			Wet Evaporator Coil	REMD16M Down-Flow Economizer	EMDH16M Horizontal Economizer	RTD11 Step-Down Diffuser			FD11 Flush Diffuser
	m <sup>3</sup> /s	cfm				2 Ends Open	1 Side 2 Ends Open	All Ends & Sides Open	
CHA16-072 CHA16-090	0.95	2000	25 (0.10)	27 (0.11)	5 (0.02)	37 (0.15)	30 (0.12)	27 (0.11)	20 (0.08)
	1.05	2200	27 (0.11)	37 (0.15)	7 (0.03)	45 (0.18)	37 (0.15)	32 (0.13)	27 (0.11)
	1.15	2400	30 (0.12)	47 (0.19)	7 (0.03)	52 (0.21)	45 (0.18)	37 (0.15)	35 (0.14)
	1.25	2600	32 (0.13)	57 (0.23)	10 (0.04)	60 (0.24)	52 (0.21)	45 (0.18)	42 (0.17)
	1.30	2800	35 (0.14)	67 (0.27)	10 (0.04)	67 (0.27)	60 (0.24)	52 (0.21)	50 (0.20)
	1.40	3000	40 (0.16)	77 (0.31)	12 (0.05)	80 (0.32)	72 (0.29)	62 (0.25)	62 (0.25)
	1.50	3200	45 (0.18)	87 (0.35)	12 (0.05)	102 (0.41)	92 (0.37)	80 (0.32)	77 (0.31)
	1.60	3400	47 (0.19)	102 (0.41)	15 (0.06)	124 (0.50)	112 (0.45)	97 (0.39)	92 (0.37)
	1.70	3600	52 (0.21)	117 (0.47)	15 (0.06)	152 (0.61)	134 (0.54)	119 (0.48)	109 (0.44)
CHA16-120	1.70	3600	30 (0.12)	35 (0.14)	7 (0.03)	90 (0.36)	70 (0.28)	57 (0.23)	37 (0.15)
	1.80	3800	32 (0.13)	37 (0.15)	10 (0.04)	99 (0.40)	80 (0.32)	65 (0.26)	45 (0.18)
	1.90	4000	35 (0.14)	40 (0.16)	10 (0.04)	109 (0.44)	90 (0.36)	72 (0.29)	52 (0.21)
	2.00	4200	37 (0.15)	42 (0.17)	12 (0.05)	122 (0.49)	99 (0.40)	82 (0.33)	60 (0.24)
	2.10	4400	40 (0.16)	45 (0.18)	12 (0.05)	134 (0.54)	109 (0.44)	92 (0.37)	67 (0.27)
	2.15	4600	42 (0.17)	50 (0.20)	15 (0.06)	149 (0.60)	122 (0.49)	104 (0.42)	77 (0.31)
	2.25	4800	45 (0.18)	55 (0.22)	17 (0.07)	162 (0.65)	132 (0.53)	114 (0.46)	87 (0.35)
	2.35	5000	47 (0.19)	60 (0.24)	22 (0.09)	172 (0.69)	144 (0.58)	124 (0.50)	97 (0.39)
CHA16-150	2.45	5200	50 (0.20)	67 (0.27)	25 (0.10)	186 (0.75)	154 (0.62)	134 (0.54)	107 (0.43)
	2.00	4200	42 (0.17)	45 (0.18)	15 (0.06)	122 (0.49)	99 (0.40)	82 (0.33)	60 (0.24)
	2.10	4400	45 (0.18)	50 (0.20)	17 (0.07)	134 (0.54)	109 (0.44)	92 (0.37)	67 (0.27)
	2.15	4600	50 (0.20)	52 (0.21)	17 (0.07)	149 (0.60)	122 (0.49)	104 (0.42)	77 (0.31)
	2.25	4800	52 (0.21)	57 (0.23)	20 (0.08)	162 (0.65)	132 (0.53)	114 (0.46)	87 (0.35)
	2.35	5000	55 (0.22)	65 (0.26)	20 (0.08)	172 (0.69)	144 (0.58)	124 (0.50)	97 (0.39)
	2.45	5200	60 (0.24)	77 (0.31)	22 (0.09)	186 (0.75)	154 (0.62)	134 (0.54)	107 (0.43)
	2.55	5400	62 (0.25)	85 (0.34)	25 (0.10)	204 (0.82)	169 (0.68)	139 (0.56)	117 (0.47)
	2.65	5600	65 (0.26)	94 (0.38)	30 (0.12)	219 (0.88)	181 (0.73)	159 (0.64)	129 (0.52)
2.75	5800	70 (0.28)	99 (0.40)	32 (0.13)	241 (0.97)	196 (0.79)	172 (0.69)	144 (0.58)	

NOTE - Electric heat has no appreciable air resistance.

<b>CEILING DIFFUSER AIR THROW DATA</b>						
Model Number	Air Volume		Effective Throw Range			
			RTD11 Step-Down		FD11 Flush	
	m <sup>3</sup> /s	cfm	m	ft.	m	ft.
CHA16-072 CHA16-090	1.25	2625	7 - 9	24 - 29	7 - 8	22 - 26
	1.40	3000	8 - 10	27 - 33	8 - 9	25 - 30
	1.60	3375	9 - 11	30 - 37	9 - 10	28 - 34
	1.75	3750	10 - 12	34 - 41	9 - 12	31 - 38
CHA16-120	2.10	4400	10 - 13	34 - 42	10 - 12	32 - 40
	2.35	4950	12 - 14	38 - 47	11 - 14	36 - 45
	2.60	5500	13 - 16	43 - 52	12 - 15	40 - 50
CHA16-150	2.00	4200	12 - 14	39 - 46	12 - 15	40 - 48
	2.35	5000	12 - 15	41 - 50	13 - 16	43 - 52
	2.75	5800	13 - 16	43 - 52	14 - 16	45 - 54

Effective Throw Range is the horizontal or vertical distance an airstream travels on leaving the outlet or diffuser before the maximum velocity is reduced to 15 m (50 ft.) per minute. Four sides open.

## GUIDE SPECIFICATIONS

### General

- Furnish and install a single package air to air direct expansion mechanical cooling system complete with automatic controls.
- The single package unit shall be a standard product of a firm regularly engaged in the manufacture of heating-cooling equipment.
- The manufacturer shall test operate system at the factory before shipment.

### Air Distribution

- Equipment shall be capable of bottom (down-flow) or side (horizontal) handling of conditioned air.

### Cooling System

- The coils shall be non-ferrous construction with aluminum fins mechanically bonded to durable copper tubes. Coils shall be pressure leak tested. Condenser coil shall be formed coil construction.
- Compressors shall be resiliently mounted and have overload protection. The refrigeration system shall have suction and liquid line service gauge ports, high pressure switches (-072-090 only), driers, freezestats and full refrigerant charge.
- Control option available shall consist of low ambient controls.

### Cabinet

- Shall be galvanized steel with a powdered enamel paint finish electrostatically bonded to the metal.
- Cabinet panels where conditioned air is handled shall be fully insulated to prevent sweating and minimize sound. Openings shall be provided for power connection entry. Bottom power entry shall be furnished.
- Evaporator coil condensate drain extended outside cabinet shall be provided.
- Lifting holes in full perimeter base rails shall be provided for rigging.

### Service Access

- Large removeable panels shall allow complete service access to compressor/heating/controls, blower and air filter/economizer compartments.

### Supply Air Blowers

- Centrifugal supply air blower shall have permanently lubricated sleeve bearings and adjustable belt drive.
- Motor mount base shall permit ease of motor changeover and belt tension adjustment with a belt tensioning lead screw.
- Blower wheel shall be statically and dynamically balanced.
- Supply air blower motor shall have ball bearings.

### Condenser Fan(s)

- Direct drive propeller type condenser fan(s) shall discharge vertically.
- Fan motor shall have ball bearings and be permanently lubricated and inherently protected.
- Fan(s) shall have a safety guard.

### Air Filters

- Disposable 51 mm (2 inch) thick pleated filters shall be furnished.

## OPTIONAL ACCESSORIES

### Additive Electric Heaters

- Electric heaters shall be available for field installation. Heating elements shall be nichrome bare wire exposed directly to the air stream. Time delays shall bring the elements on and off in sequence with a time delay between each element.
- Limit controls shall provide overload and short circuit protection.
- Optional unit fuse block shall be required on electric heaters.

### Roof Mounting Frame

- Mechanical contractor shall install a steel roof mounting frame for bottom discharge and return air duct connection.
- Shall mate to the bottom perimeter of the equipment.
- When flashed into the roof it shall make a unit mounting curb and provide weatherproof duct connection and entry into the conditioned area.
- Flashing shall be the responsibility of a roofing contractor.

### Economizer Damper Section

- Furnish and install economizer complete with recirculated air dampers, outside air dampers, damper actuator and controls.
- Low leakage dampers shall ride in nylon bearings. The economizer section shall provide for the introduction of up to 100% outdoor air for minimum ventilation and free cooling.
- Integrated economizer cycle shall allow compressors to cycle for dehumidification and additional cooling, as needed, with 100% outdoor air intake.
- Damper actuator shall be 24 volt, fully modulating spring return. Controls shall include fixed 13°C (55°F) mixed air controller, damper actuator, adjustable minimum position switch and solid-state adjustable outdoor air enthalpy control.
- Damper hood (required and ordered separately) with filters shall be galvanized steel with a powdered enamel paint finish electrostatically bonded to the metal.
- Gravity exhaust dampers shall be required and ordered separately for down-flow air applications and optional for horizontal applications.

### Economizer Gravity Exhaust Dampers

- Pressure operated dampers shall be required for field installation on economizer in down-flow air applications.
- Dampers shall be available as an option for field installation in return air duct for horizontal air applications.
- Neoprene coated fiberglass dampers shall prevent blow-back and outdoor air infiltration during off cycle.

### Outdoor Air Damper Section

- Outdoor dampers shall be available to provide outdoor air requirements of up to 25%.
- Shall be available for manual or automatic (with optional motorized damper kit) operation.
- Hood with filters shall be galvanized steel with a powdered enamel paint finish electrostatically bonded to the metal.
- Damper/hood assembly shall be field installed external to the unit in down-flow applications.
- Optional panel kit that replaces unit panel shall be required for damper/hood installation in down-flow applications.
- Damper/hood assembly field shall be field installed in return air duct in in horizontal applications.

### Horizontal Supply & Return Air Kit

- Optional kit shall provide necessary cabinet parts to field convert unit for side (horizontal) supply and return air duct connections.

### Ceiling Diffusers

- Furnish and install a (flush or stepdown) optional combination ceiling supply and return air diffuser.
- Supply and return transitions shall be available, for field installation in the roof mounting frame, to provide duct connection to the diffuser.

### Control Systems

- Shall provide a selection of thermostats and related controls to automatically operate the mechanical equipment through the heating or cooling and ventilating cycles as required.

# DIMENSIONS - MM (INCHES)

## Basic Unit

### CORNER WEIGHTS

Model Number	AA		BB		CC		DD	
	kg	lbs.	kg	lbs.	kg	lbs.	kg	lbs.
CHA16-072	71	156	84	186	78	172	67	147
CHA16-090	91	201	131	289	86	189	59	131
CHA16-120	106	233	137	302	116	255	95	210
CHA16-150	112	246	151	333	133	293	103	228

### CENTER OF GRAVITY

Model Number	EE		FF	
	mm	inch	mm	inch
CHA16-072	699	27-1/2	1003	39-1/2
CHA16-090	737	29	921	36-1/2
CHA16-120	940	37	1156	45-1/2
CHA16-150	908	35-3/4	1054	41-1/2

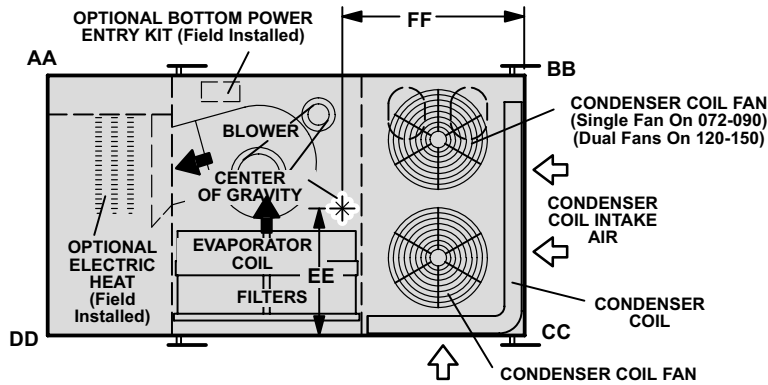

TOP VIEW

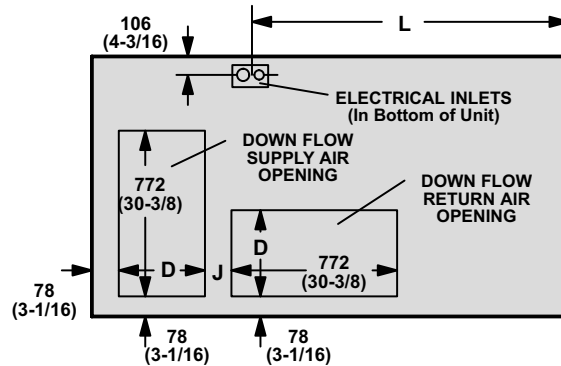

TOP VIEW BASE SECTION

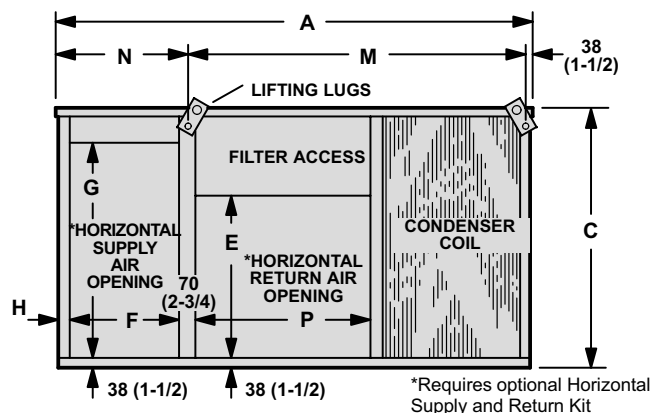

BACK VIEW WITH HORIZONTAL SUPPLY & RETURN AIR OPENING

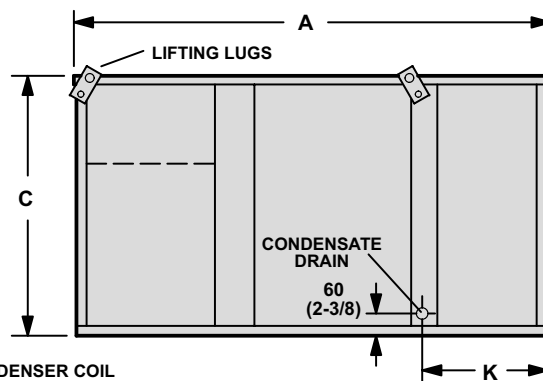

CONDENSER COIL EXHAUST AIR (Single Fan On 072-090, Dual Fans On 120-150)

FRONT VIEW

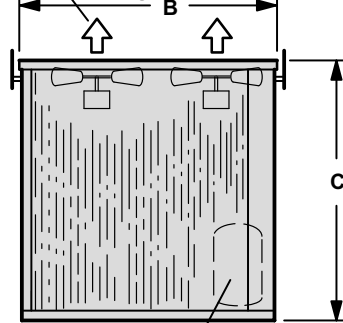

CONDENSER SECTION END VIEW

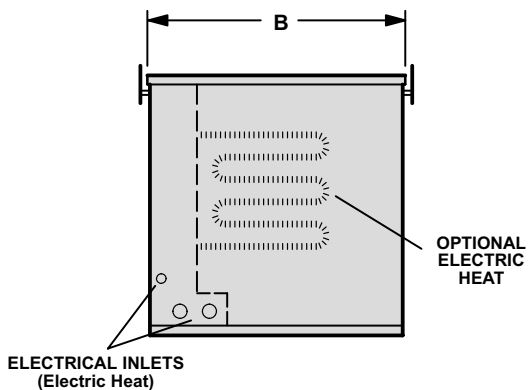

HEAT SECTION END VIEW

Model Number	A		B		C		D		E		F		G	
	mm	in.	mm	in.	mm	in.	mm	in.	mm	in.	mm	in.	mm	in.
CHA16-072 CHA16-090	2248	88-1/2	1219	48	991	39	419	16-1/2	625	24-5/8	494	19-7/16	816	32-1/8
CHA16-120	2388	94	1524	60	1168	46	610	24	803	31-5/8	641	25-1/4	994	39-1/8
CHA16-150	2591	102	1524	60	1168	46	610	24	803	31-5/8	641	25-1/4	994	39-1/8

Model Number	H		J		K		L		M		N		P	
	mm	in.	mm	in.	mm	in.	mm	in.	mm	in.	mm	in.	mm	in.
CHA16-072 CHA16-090	41	1-5/8	143	5-5/8	635	25	1384	54-1/2	1648	64-7/8	562	22-1/8	838	33
CHA16-120	51	2	113	4-7/16	791	31-1/8	1461	57-1/2	1626	64	724	28-1/2	838	33
CHA16-150	51	2	113	4-7/16	791	31-1/8	1664	65-1/2	1829	72	724	28-1/2	1041	41

## ACCESSORY DIMENSIONS - MM (INCHES)

### Basic Unit with REMD16M (Down-Flow) Economizer Damper Section and RMF16 Roof Mounting Frame

#### CORNER WEIGHTS

Model Number	AA		BB		CC		DD	
	kg	lbs.	kg	lbs.	kg	lbs.	kg	lbs.
CHA16-072	89	197	98	217	95	210	82	181
CHA16-090	93	204	123	271	118	260	89	196
CHA16-120	130	286	137	301	119	262	114	252
CHA16-150	121	267	163	359	149	329	115	254

#### CENTER OF GRAVITY

Model Number	EE		FF	
	mm	inch	mm	inch
CHA16-072	622	24-1/2	1003	39-1/2
CHA16-090	622	24-1/2	965	38
CHA16-120	991	39	1156	45-1/2
CHA16-150	958	37-3/4	1054	41-1/2

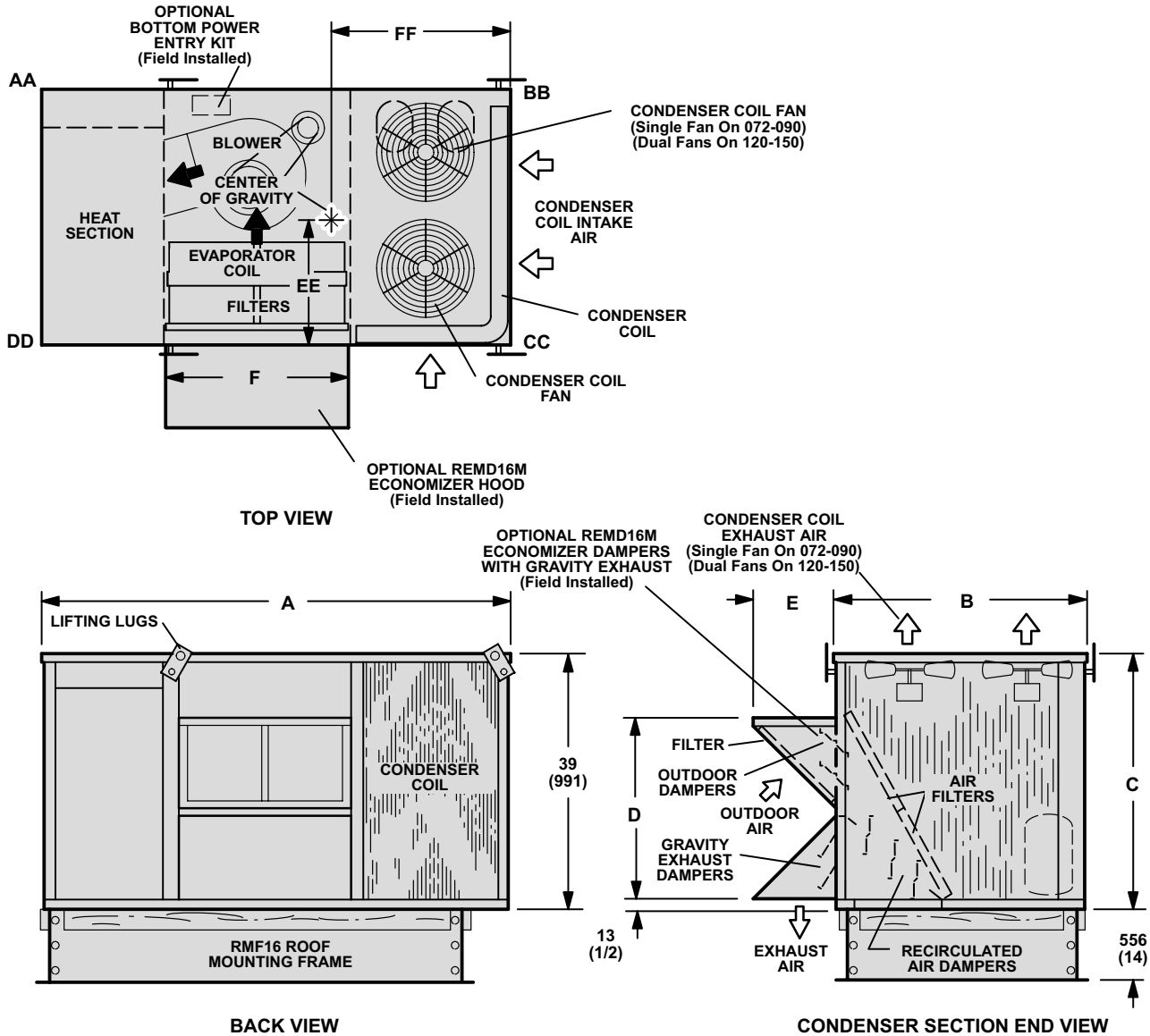

Model Number	A		B		C		D		E		F	
	mm	in.	mm	in.	mm	in.	mm	in.	mm	in.	mm	in.
CHA16-072 CHA16-090	2248	88-1/2	1219	48	991	39	654	25-3/4	394	15-1/2	826	32-1/2
CHA16-120	2388	94	1524	60	1168	46	841	33-1/8	464	18-1/4	826	32-1/2
CHA16-150	2591	102	1524	60	1168	46	841	33-1/8	464	18-1/4	1029	40-1/2

# ACCESSORY DIMENSIONS - MM (INCHES)

## Basic Unit with EMDH16M (Horizontal) Economizer Damper Section

### CORNER WEIGHTS

Model Number	AA		BB		CC		DD	
	kg	lbs.	kg	lbs.	kg	lbs.	kg	lbs.
CHA16-072	78	173	93	204	92	202	78	171
CHA16-090	107	233	147	325	111	244	79	175
CHA16-120	127	279	133	293	122	270	117	259
CHA16-150	121	266	161	355	151	333	116	256

### CENTER OF GRAVITY

Model Number	EE		FF	
	mm	inch	mm	inch
CHA16-072	622	24-1/2	1003	39-1/2
CHA16-090	700	27-1/2	940	37
CHA16-120	864	34	1156	45-1/2
CHA16-150	864	34	1156	45-1/2

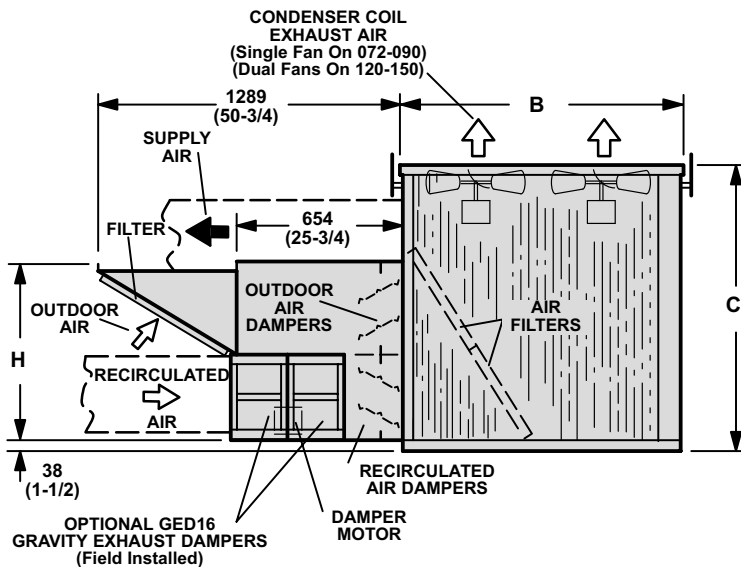
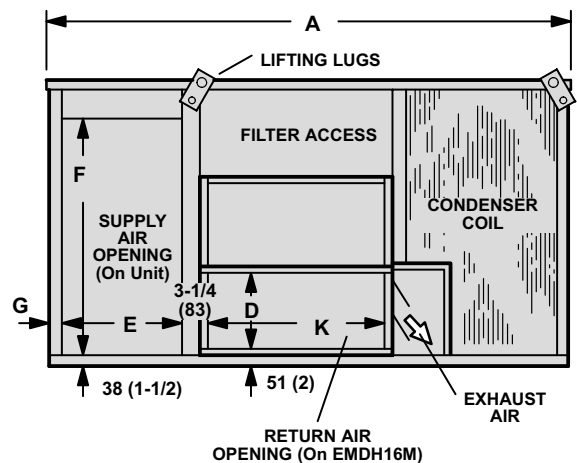
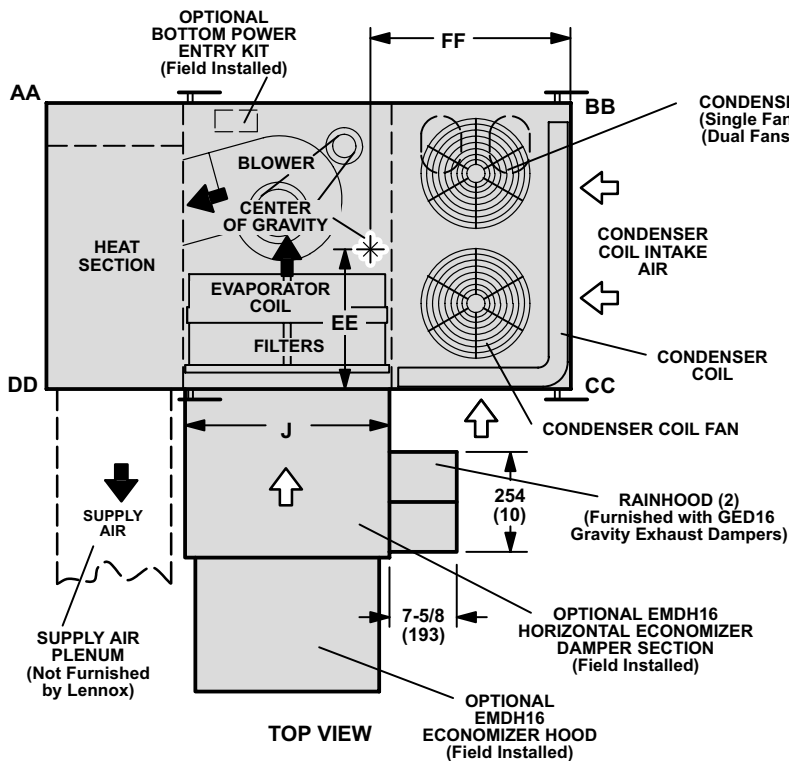

Model Number	A		B		C		D		E		F		G		H		J		K	
	mm	in.	mm	in.	mm	in.	mm	in.	mm	in.	mm	in.	mm	in.	mm	in.	mm	in.	mm	in.
CHA16-072 CHA16-090	2248	88-1/2	1219	48	991	39	337	13-1/4	494	19-7/16	816	32-1/2	41	1-5/8	730	28-3/4	827	32-9/16	800	31-1-2
CHA16-120	2388	94	1524	60	1168	46	489	19-1/4	641	25-1/4	994	39-1/8	51	2	883	34-3/4	827	32-9/16	800	31-1/2
CHA16-150	2591	102	1524	60	1168	46	489	19-1/4	641	25-1/4	994	39-1/8	51	2	883	34-3/4	1030	40-9/16	1003	39-1/2

**ACCESSORY DIMENSIONS - MM (INCHES)**

**RMF16 SERIES ROOF MOUNTING FRAME WITH DOUBLE DUCT OPENING**

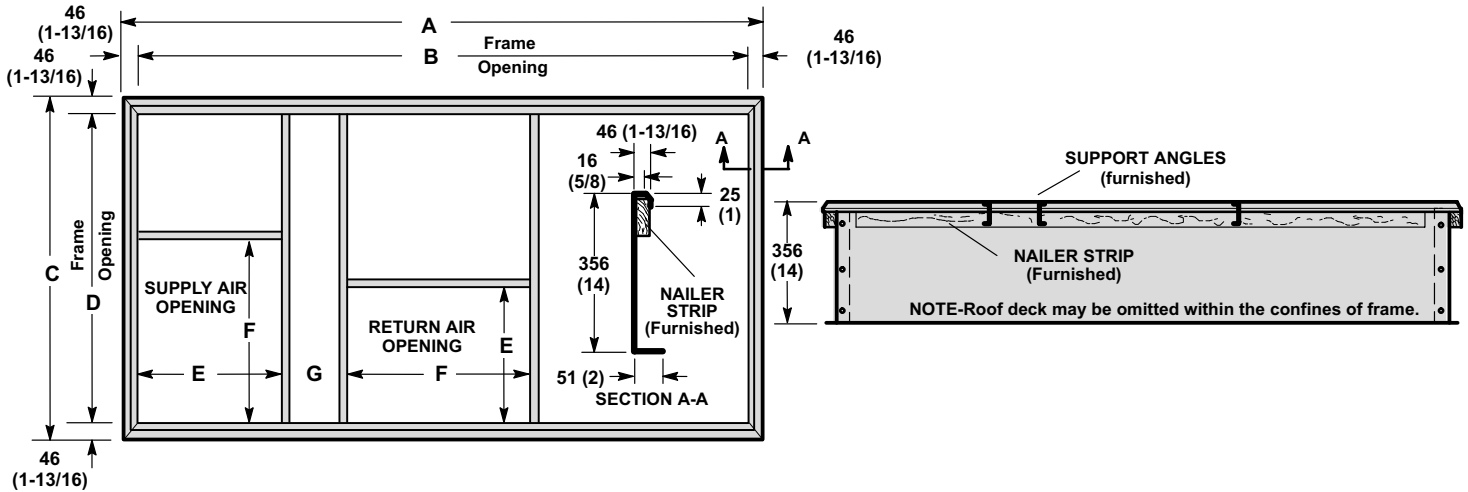

Model Number	A		B		C		D		E		F		G	
	mm	inch	mm	inch	mm	inch	mm	inch	mm	inch	mm	inch	mm	inch
RMF16-09	2213	87-1/8	2121	83-1/2	1184	46-5/8	1092	43	456	17-15/16	800	31-1/2	102	4
RMF16-12	2350	92-1/2	2257	88-7/8	1486	58-1/2	1394	54-7/8	641	25-1/4	800	31-1/2	79	3-1/8

**RMF16-09 ROOF MOUNTING FRAME WITH SRT16-09 SUPPLY AND RETURN AIR TRANSITIONS FOR FD11-95 & RTD11-95 CEILING DIFFUSERS**

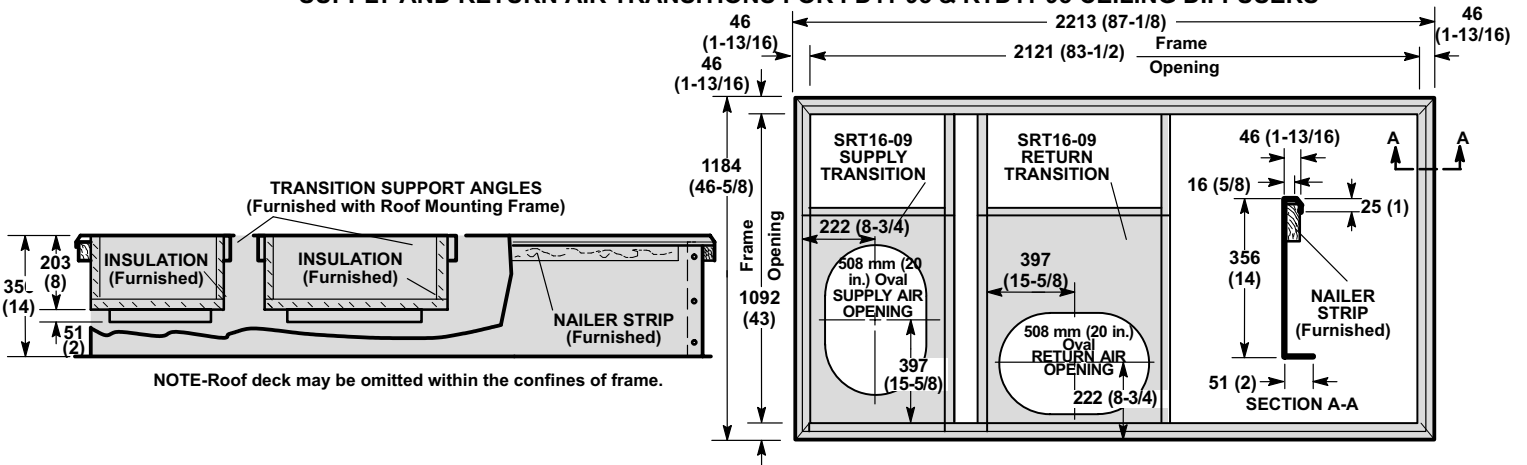

**RMF16-12 ROOF MOUNTING FRAMES WITH SRT16-12 SUPPLY AND RETURN AIR TRANSITIONS FOR FD11-135 & RTD11-135 CEILING DIFFUSERS**

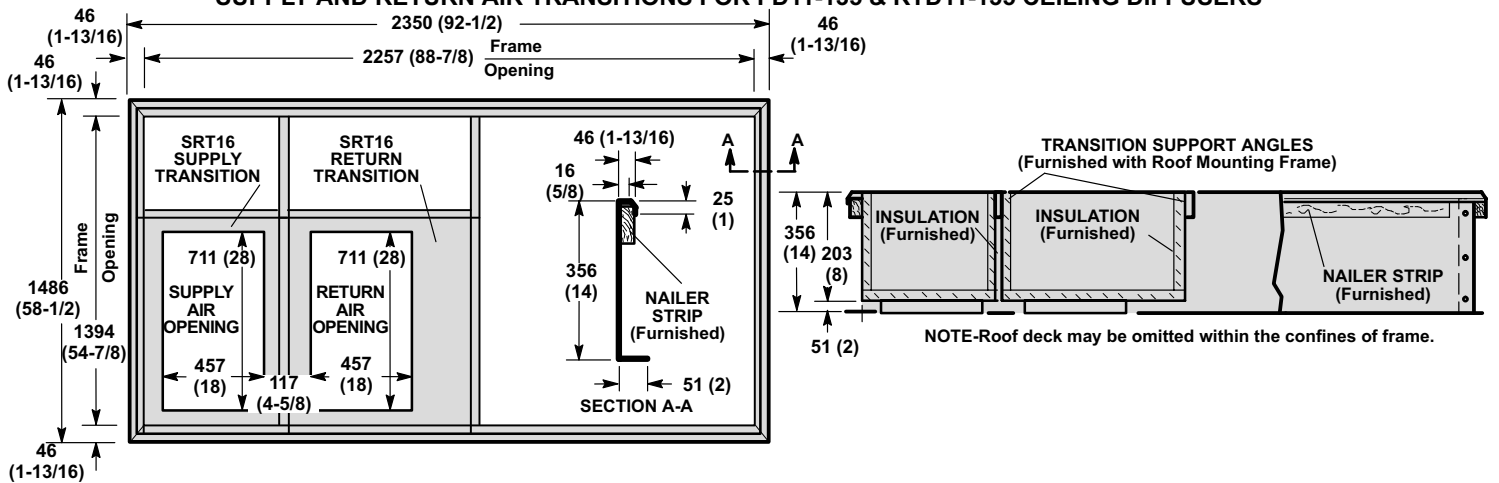



**ACCESSORY DIMENSIONS - MM (INCHES)**

**TYPICAL FLASHING DETAIL FOR RMF16 ROOF MOUNTING FRAME**

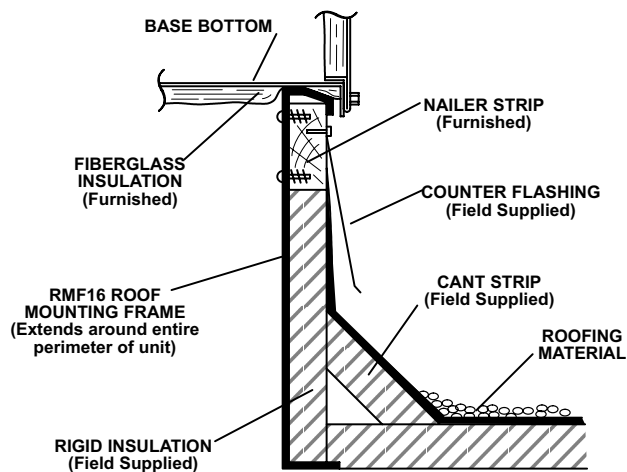

**ROOF MOUNTING FRAME SPECIFICATIONS**

Roof Mounting frame is rigid enough to be spanned over its entire length or cantilevered if supported on both sides of center of gravity.

Roof Mounting Frames	RMF16
*Moment of inertia (I) (in. <sup>4</sup> ) (cm <sup>4</sup> )	42 (1748)
*Section modulus $\frac{I}{C}$ (cm <sup>3</sup> ) (in. <sup>3</sup> )	5.8 (95)
Maximum weight (kg/m) (lb/ft.) of length	5.5 (8.2)
Design strength (psi) (kPa)	20 000 (137 900)

\*Includes both sides of frame.

**CHA16 UNIT WITH OAD16 OUTDOOR AIR DAMPER SECTION  
DOWN-FLOW SUPPLY AND RETURN AIR**

NOTE - For Horizontal (Side) Supply And Return Air, OAD16 Field Installs on Return Air Duct  
Panel Kit not required for horizontal applications.

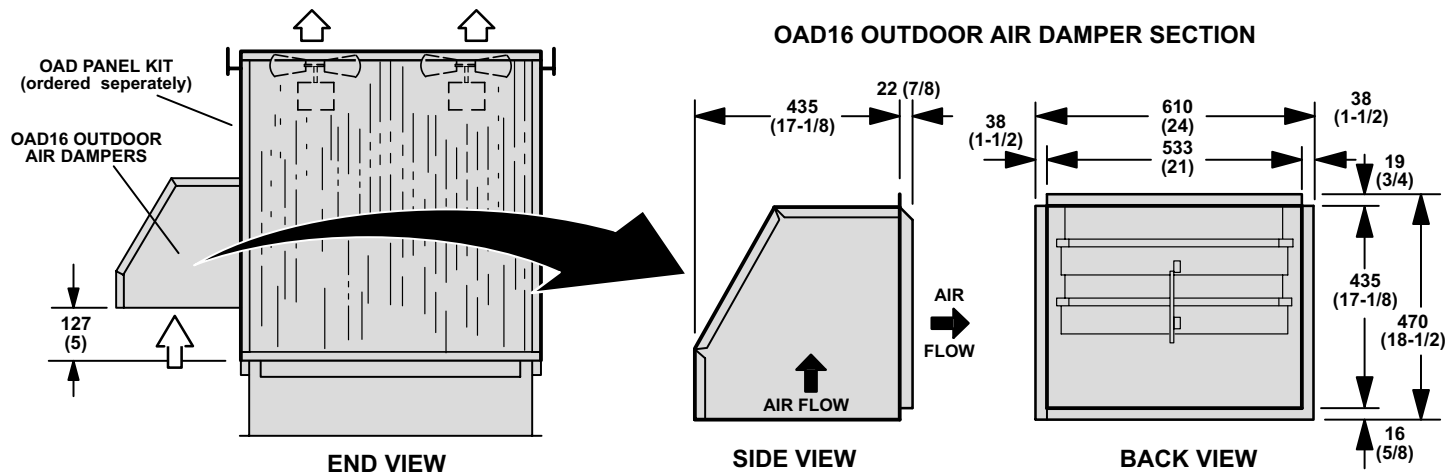

**COMBINATION CEILING SUPPLY AND RETURN DIFFUSERS**

**RTD11-95 STEP-DOWN CEILING DIFFUSER**

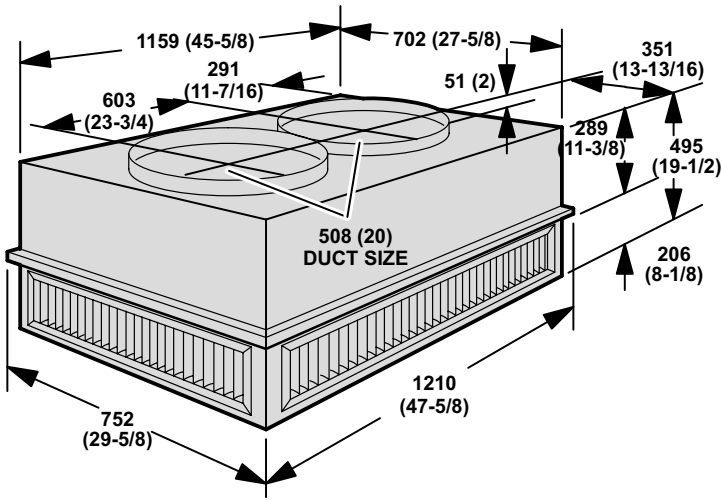

**FD11-95 FLUSH CEILING DIFFUSER**

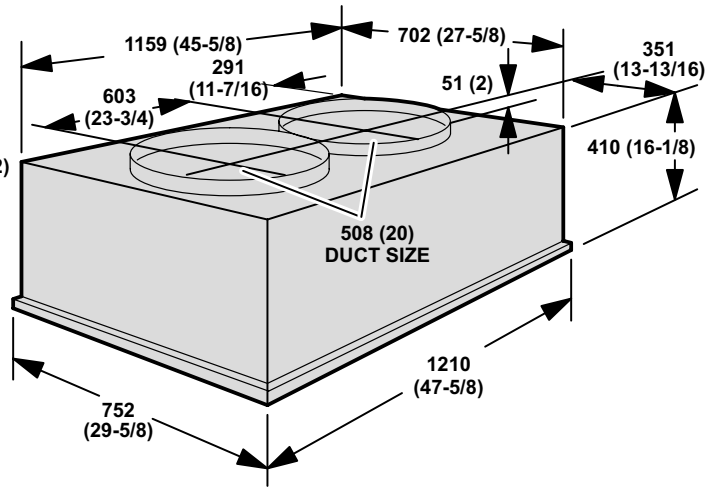

**RTD11-135 STEP-DOWN CEILING DIFFUSER**

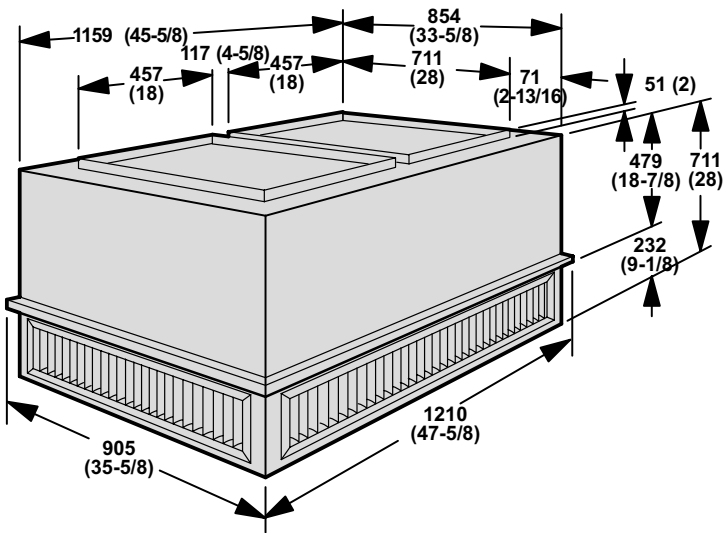

**FD11-135 FLUSH CEILING DIFFUSER**

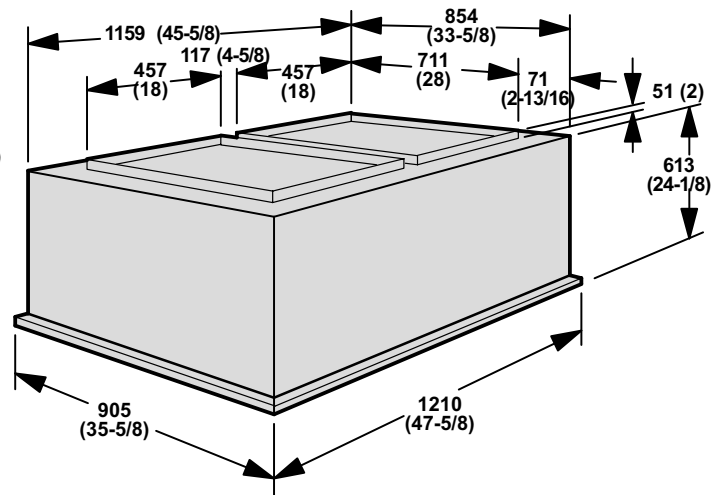

**INSTALLATION CLEARANCES - MM (INCHES)**

**CHA16 BASIC UNIT**

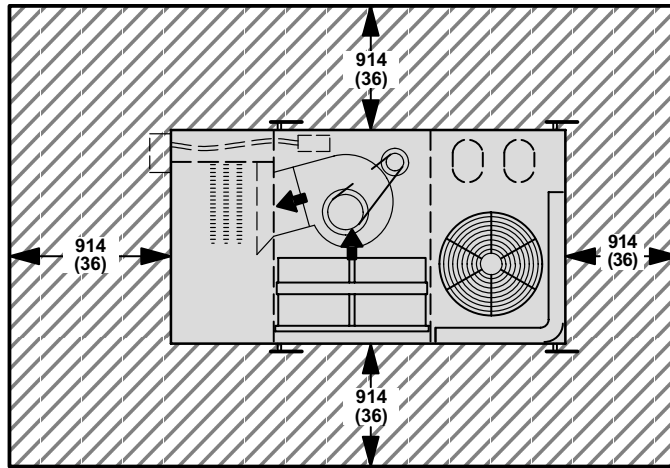

NOTE - Top Clearance Unobstructed.

NOTE - Entire perimeter of unit requires support when elevated above mounting surface.

**CHA16 UNIT WITH REMD16M ECONOMIZER DAMPER SECTION OR OAD16 OUTDOOR AIR DAMPER SECTION**

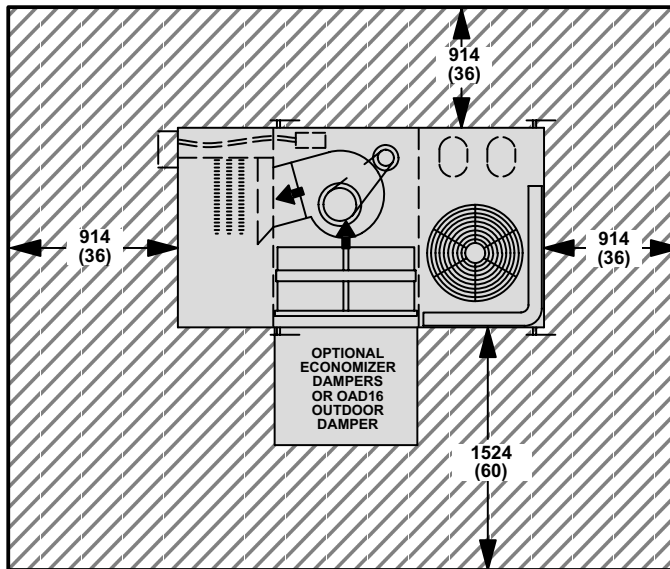

NOTE - Top Clearance Unobstructed.

**CHA16 UNIT WITH EMDH16M HORIZONTAL ECONOMIZER DAMPER SECTION**

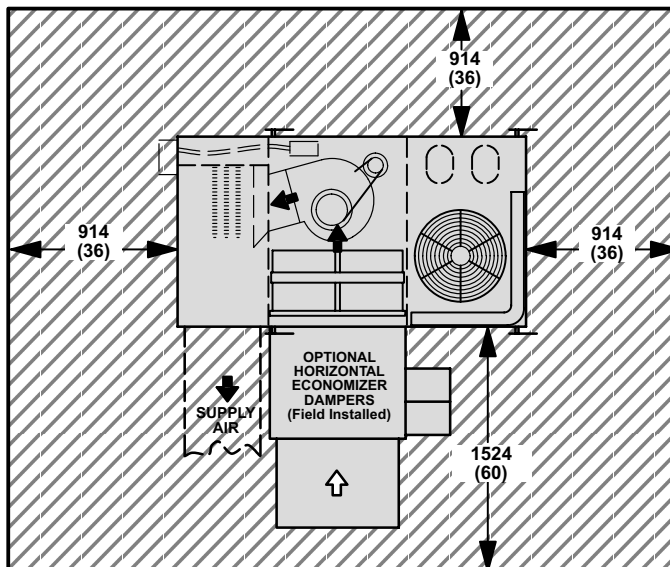

NOTE - Top Clearance Unobstructed.