



**COMMERCIAL
 PRODUCT SPECIFICATIONS**

Bulletin No. 490173
 November 2021
 Supersedes November 2019

**ELITE®
 SERIES**



072-090 Models



120-150 Models



180-240 Models

21 to 70 kW
Cooling Capacity - 18.7 to 58.9 kW

MODEL NUMBER IDENTIFICATION

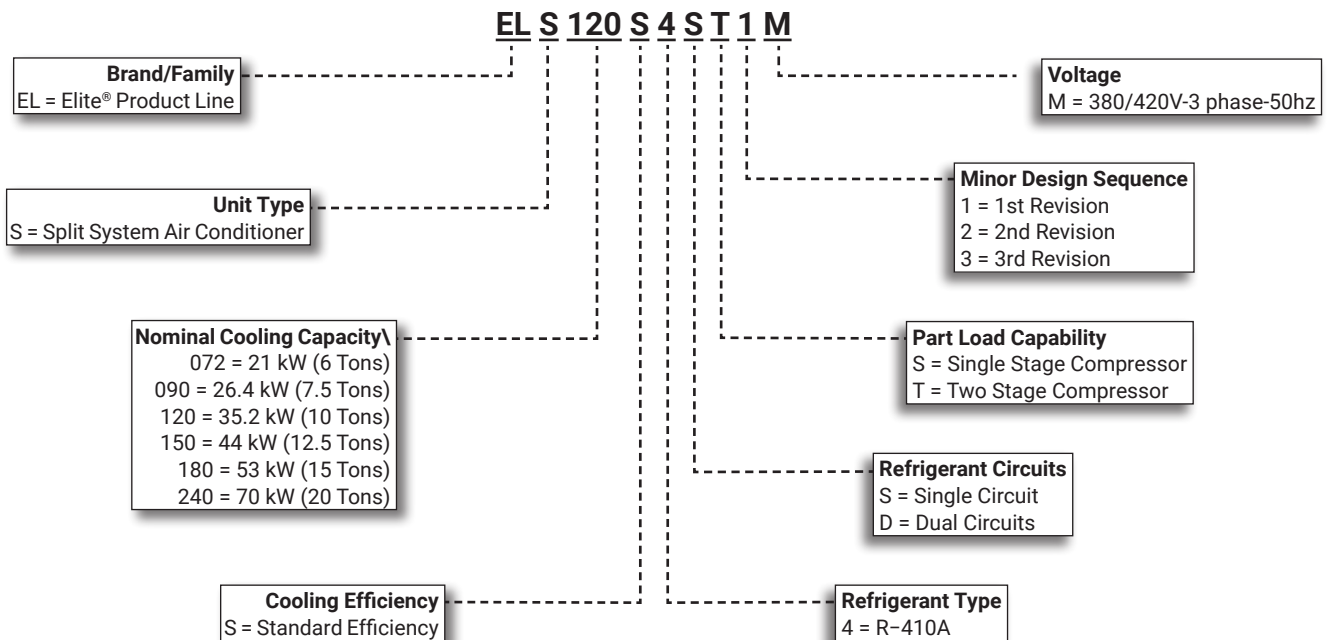

FEATURE HIGHLIGHTS

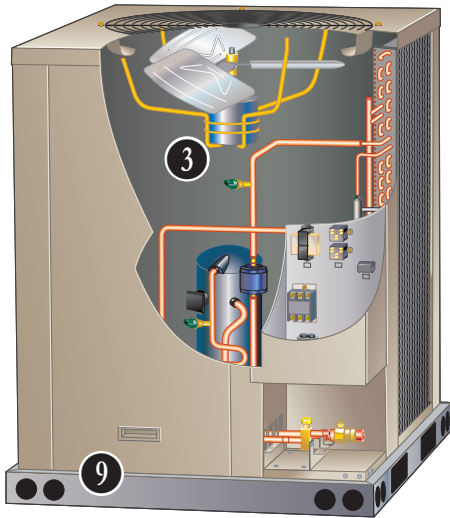

072-090 Models

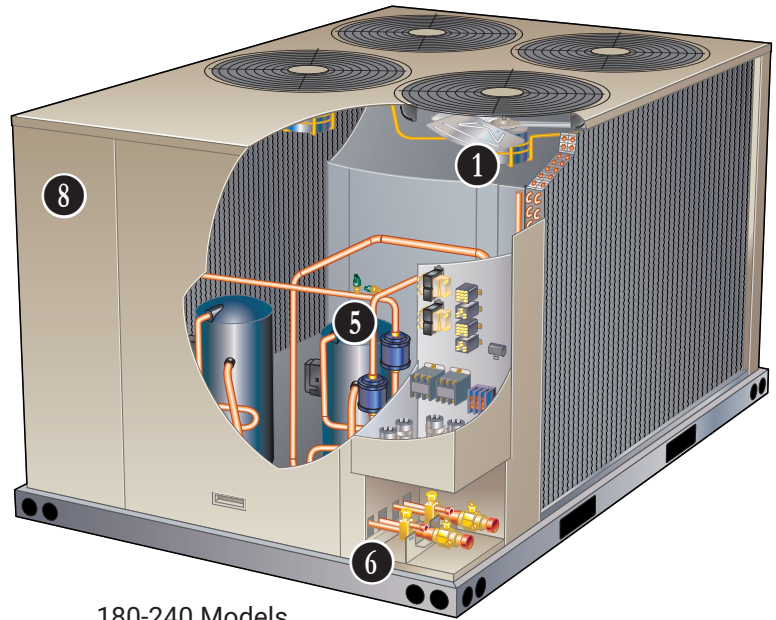

180-240 Models

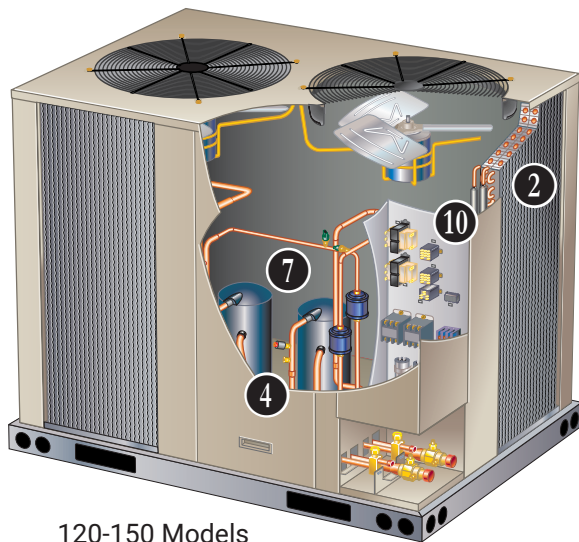

120-150 Models

1. Outdoor Coil Fans
2. Copper Tube/Enhanced Fin Coils
3. High Pressure Switch
4. Loss of Charge Switch
5. Hi-Capacity Driers
6. Refrigerant Lines and Service Valves
7. Scroll Compressors
8. Heavy Gauge Pre-Painted Steel Cabinet
9. Heavy Duty Steel Base Rails
10. Cabinet

CONTENTS

Approvals	3
Dimensions	12
Electrical Data	7
Features And Benefits	3
Model Number Identification	1
Optional Conventional Temperature Control Systems	6
Options / Accessories	9
Ratings	15
Sound Data	9
Specifications	7
System Matches	10
Unit Clearances	11
Weight Data	8

APPROVALS

APPROVALS

- All units tested in Lennox' Research Laboratory environmental test room or ETL certified environmental testing facility
- Cooling performance is rated at test conditions included in Air-Conditioning, Heating and Refrigeration Institute (AHRI) Standard 340/360-2015 while operating at rated voltage and air volumes
- Sound tested in Lennox reverberant sound test room in accordance with test conditions included in AHRI Standard 270 or 370
- Components bonded for grounding to meet safety standards for servicing required by Underwriters Laboratories (UL) and the International Electrotechnical Commission (IEC)
- International Organization for Standardization (ISO) 9001 Registered Manufacturing Quality System

FEATURES AND BENEFITS

APPLICATIONS

- Available in 21, 26.4, 35.2 kW (one compressor) and 35.2, 44, 53 and 70 kW (two compressors) nominal sizes
- Applicable to matching indoor air handlers and indoor add-on coils
- Shipped completely factory assembled, piped, and wired
- Each unit is test operated at the factory

REFRIGERATION SYSTEM

R-410A Refrigerant

- Non-chlorine, ozone friendly

NOTE - Refrigerant is not furnished and must be field supplied.

1 Outdoor Coil Fan(s)

- ELS072 and ELS090 units have one outdoor fan
- ELS120 and ELS150 units have two outdoor fans
- ELS180 and ELS240 units have four outdoor fans
- Direct drive fan(s) moves large volumes of air uniformly through entire condenser coil for high refrigerant cooling capacity
- Totally enclosed fan motors
- Overload protected
- Rain shield furnished

2 Copper Tube/Enhanced Fin Coils

- Wrap-around "U" Shaped Coil - ELS072-090-120 models
- Two "L" Shaped Coils - ELS150-180-240 models
- Lennox designed and fabricated coils
- Ripple-edge aluminum fins
- Seamless copper tube construction
- Lanced fins for maximum fin surface exposure
- Fin collars grip tubing for maximum contact area
- Flared shoulder tubing connections
- Machine brazed silver soldering
- Factory tested under high pressure
- Completely accessible for cleaning

3 High Pressure Switch

- Protects the system from high pressure conditions
- Manual reset

4 Loss of Charge Switch

- Shuts off unit if liquid line pressure falls below setting
- Provides loss of charge and freeze-up protection
- Automatic reset

5 Hi-Capacity Drier(s)

- Traps moisture or dirt

6 Refrigerant Lines and Service Valves

- Suction and liquid lines located on corner of unit
- Sweat connections
- See dimension drawings
- Fully serviceable suction and liquid line service valves provide complete service access to refrigerant system
- Suction valve can be fully shut off, while liquid valve can be front seated to manage refrigerant charge while servicing system
- Accessible outside of unit cabinet

SCROLL COMPRESSORS

- 7 • One Two-Stage Compressor - ELS072**S4S**, ELS090**S4S** and ELS120**S4S** models
- Two-Single-Stage Compressors - ELS120**S4D**, ELS150**S4D**, ELS180**S4D** and ELS240**S4D**
- High efficiency with uniform suction flow
- Constant discharge flow, high volumetric efficiency and quiet operation
- Low gas pulses during compression reduces operational sound levels
- Compressor motor is internally protected from excessive current and temperature
- Muffler in discharge line reduces operating sound levels
- Compressor is installed in the unit on resilient rubber mounts for vibration free operation

FEATURES AND BENEFITS

COMPRESSORS (continued)

Scroll Compressor Operation

- Two involute spiral scrolls matched together generate a series of crescent-shaped gas pockets between them
- During compression, one scroll remains stationary while the other scroll orbits around it
- Gas is drawn into the outer pocket, the pocket is sealed as the scroll rotates
- As the spiral movement continues, gas pockets are pushed to the center of the scrolls
- Volume between the pockets is simultaneously reduced
- When the pocket reaches the center, gas is now at high pressure and is forced out of a port located in the center of the fixed scrolls
- During compression, several pockets are compressed simultaneously resulting in a smooth continuous compression cycle
- Continuous flank contact, maintained by centrifugal force, minimizes gas leakage and maximizes efficiency
- Compressor is tolerant to the effects of slugging and contaminants
- If this occurs, scrolls separate, allowing liquid or contaminants to be worked toward the center and discharged

ELS072S4S, ELS090S4S and ELS120S4S Two-Stage Models

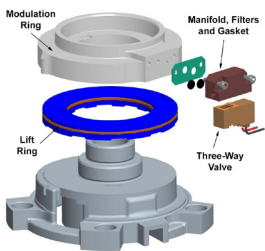

- A 24-volt DC solenoid valve inside the compressor controls staging
- When the 3-way solenoid is energized it moves the lift ring assembly to block the ports and the compressor operates at full-load or 100% capacity
- When the solenoid is de-energized the lift ring assembly moves to unblock the compressor ports and the compressor operates at part-load or approximately 67% of its full-load capacity
- The “loading” and “unloading” of the two stage scroll is done “on the fly” without shutting off the single-speed compressor motor between stages

Crankcase Heater

- Crankcase heater(s) prevents migration of liquid refrigerant into compressor(s) and ensures proper compressor lubrication

CABINET

- 8 • Heavy-gauge, pre-painted steel cabinet
- Removable panels for unit servicing
- 9 • Heavy duty steel base rails raise the unit off of mounting surface
- Unit lifting holes and forklift slots furnished in base rails
- See dimension drawings
- 10 • Control Box
- Control box located in separate compartment in unit cabinet
- All controls are pre-wired at the factory
- Control box is large enough for field installed DDC or other field supplied control modules

Options/Accessories

Factory Installed

Corrosion Protection

- Available for enhanced condenser coil corrosion protection
- Polymeric epoxy coating deposited by electrical transport (electrophoresis) using a process known as electrocoat (e-coat)
- Painted base pan furnished

Field Installed

Combination Coil/Hail Guards

- Heavy gauge steel frame with expanded metal mesh to protect the outdoor coil from damage

FEATURES AND BENEFITS

CONTROLS

Options/Accessories

Field Installed

Low Ambient Control

- Air conditioning units operate satisfactorily down to 45°F outdoor air temperature without any additional controls
- Kit allows unit operation down to 0°F
- Head pressure speed controller reduces outdoor fan operation during low ambient conditions until head pressure rises to the setpoint
- Pressure transducers are mounted on the liquid lines
- High pressure switches are furnished to replace existing switches
- Wiring harnesses are furnished for simple plug-in wiring to fans and controller

Indoor Air Quality (CO₂) Sensors

- Monitors CO₂ levels
- Adjusts economizer dampers as needed

Thermostat

- Thermostat is not furnished with unit and must be ordered extra
- See page 6, also see individual Thermostat bulletins and Lennox Price Book

Furnace Twinning Panel

- Required to operate two identical furnaces simultaneously from a single thermostat
- For single stage conventional (1 heat/1 cool), multi-stage conventional (2 heat/2 cool) and heat pump (3 heat/2 cool) equipment
- Can be used with common or separate ducted systems
- Contains PC Control Board with terminal strip connections for thermostat and HVAC equipment
- LEDs indicate system operating status
- Uses standard 18-gauge thermostat wire
- Power Supply: 24 VAC, 40VA (transformer not furnished)
- Mounting base with hardware furnished
- Dimensions (H x W x D): 10 x 5 x 2 in.

NOTE - Only identical furnaces should be twinned in order to ensure that both furnace blowers start at the same time. If furnaces are not identical, back draft dampers can be installed in either the supply or return duct.

Up to four identical furnaces can be twinned.
Requires two panels that are wired together.

Aftermarket Unit Controller Options

- See Options/Accessories table for selection

OPTIONAL CONVENTIONAL TEMPERATURE CONTROL SYSTEMS

ComfortSense® 7500 Commercial 7-Day Programmable Thermostat



- Four-Stage Heating / Two-Stage Cooling
- Universal Multi-Stage
- Intuitive Touchscreen Interface
- Automatic Changeover between Heating and Cooling
- Full Seven-Day Programming
- Four Time Periods Per Day
- Temperature and Humidity Control
- One-Touch Away Mode
- Holiday Scheduling
- Smooth Setback Recovery (SSR)
- Performance Reports
- Notifications/Reminders
- Dehumidification/Humiditrol® Control for Split Systems and Rooftop Units
- Economizer Relay Control
- Backlit Display
- Wallplate Furnished
- FDD, ASHRAE and IECC Compliant

ComfortSense® 3000 Commercial 5-2 Day Programmable Thermostat



- Two-Stage Heating / Two-Stage Cooling
- Conventional Systems
- Intuitive Interface
- 5-2 Day Programming
- Program Hold
- Remote Indoor Temperature Sensing
- Smooth Setback Recovery (SSR)
- Economizer Relay Control
- Maintenance/Filter/Service Reminders
- Backlit Display
- Wallplate Furnished
- Simple Up and Down Temperature Control

ComfortSense® Non-Programmable Thermostat



- One-Stage Heating / Cooling
- Conventional Systems
- Intuitive Interface
- Manual Changeover
- Backlit Display
- Simple Up and Down Temperature Control

OPTIONAL CONVENTIONAL TEMPERATURE CONTROL SYSTEMS

Description	Catalog No.
ComfortSense® 7500 Commercial 7-Day Programmable Thermostat	
CS7500 7-Day Thermostat	17G74
Sensors/Accessories	
² Remote non-adjustable wall-mount 20k	47W36
² Remote non-adjustable wall-mount 10k	47W37
Remote non-adjustable discharge air (duct mount)	19L22
Outdoor temperature sensor	X2658
ComfortSense® 3000 Commercial 5-2 Day Programmable Thermostat	
CS3000 5-2 Day Thermostat	11Y05
Sensors/Accessories	
Remote non-adjustable wall mount 10k averaging	47W37
Thermostat wall mounting plate	X2659
ComfortSense® Non-Programmable Thermostat	
CS3000 Non-Programmable Thermostat	51M32
Universal Thermostat Guard with Lock (clear)	
Inside Dimensions (H x W) 5 7/8 x 8 3/8 in.	39P21

¹ Up to nine of the same type remote temperature sensors can be connected in parallel.

² Remote wall-mount sensors can be applied in any of the following combinations:

One Sensor - (1) 47W36, Two Sensors - (2) 47W37, Three Sensors - (2) 47W36 and (1) 47W37
Four Sensors - (4) 47W36, Five Sensors - (3) 47W36 and (2) 47W37

SPECIFICATIONS		21 KW 26.4 KW
General	Model Number	ELS072S4S
Data	Nominal Size - kW	21.0
Connections	Liquid line - in. (o.d)	(1) 3/8
(sweat)	Suction line - in. (o.d)	(1) 1-1/8
Refrigerant	Factory Charge	R-410A holding charge - 0.9 kg (2 lbs.) per circuit
(R-410A)	No. of Circuits	1
	¹ Field charge - 7.6 m (25 ft.) line set	8.0 kg (18 lbs. 0 oz.) (includes holding charge)
Compressor		(1) Two Stage Scroll
Condenser	Net face area - m ² (sq. ft.) Outer coil	2.72 (29.3)
Coil	Inner coil	1.32 (14.2)
	Tube diameter - mm (in.) & no. of rows	9.5 (3/8) - 1.5
	Fins per m (inch)	787 (20)
Condenser	Diameter - mm (in.) & number of blades	(1) 610 (24) - 3
Fan(s)	Nominal Motor W (hp)	(1) 249 (1/3)
	Total air volume - L/s (cfm)	1850 (3920)
	Rev/min	900
	Watts	300

ELECTRICAL DATA		380/420V	380/420V
	Line voltage data - 50 hz - 3 phase	380/420V	380/420V
	² Maximum Overcurrent Protection (amps)	15	25
	³ Minimum circuit ampacity	12	17
Compressor	Number of Compressors	1	1
	Rated load amps	8.5	12
	Locked rotor amps	66	94
Condenser	Number of motors	1	1
Fan Motor	Full load amps	0.8	1.5
(1 phase)	Locked rotor amps	2.4	3

NOTE - Extremes of operating range are plus and minus 10% of line voltage.

¹ Field provided charge with 7.6 m (25 ft.) line set. Refer to the Lennox Refrigerant Piping Manual to determine refrigerant charge required with longer length refrigerant lines.

² Heating Air-Conditioning Refrigeration type breaker or fuse.

³ Refer to local codes to determine wire, fuse and disconnect size requirements.

SPECIFICATIONS		35.2 KW
General	Model Number	ELS120S4S
Data	Nominal Size - kW	35.2
Connections	Liquid line - in. (o.d)	(1) 5/8
(sweat)	Suction line - in. (o.d)	(1) 1-1/8
Refrigerant	Factory Charge	R-410A holding charge - 0.9 kg (2 lbs.) per circuit
(R-410A)	No. of Circuits	1
	¹ Field charge	15.5 kg (32 lbs. 0 oz.) (includes holding charge)
	7.6 m (25 ft.) line set	5.4 kg (12 lbs. 0 oz.) (includes holding charge)
	Circuit 2	5.4 kg (12 lbs. 0 oz.) (includes holding charge)
Compressor		(1) Two Stage Scroll
Condenser	Net face area - m ² (sq. ft.) Outer coil	2.72 (29.3)
Coil	Inner coil	2.64 (28.4)
	Tube diameter - mm (in.) & no. of rows	9.5 (3/8) - 2
	Fins per m (inch)	787 (20)
Condenser	Diameter - mm (in.) & number of blades	(2) 610 (24) - 3
Fan(s)	Nominal Motor - Number and W (hp)	(2) 249 (1/3)
	Total air volume - L/s (cfm)	3270 (6930)
	Rev/min	900
	Watts	630

ELECTRICAL DATA		380/420V	380/420V
	Line voltage data - 50 hz - 3 phase	380/420V	380/420V
	² Maximum Overcurrent Protection (amps)	30	20
	³ Minimum circuit ampacity	21	16
Compressor	Number of Compressors	1	2
	Rated load amps (total)	14.8	6.3 (12.6)
	Locked rotor amps (total)	130	60 (120)
Condenser	Number of motors	2	2
Fan Motor	Full load amps each (total)	0.8 (1.6)	0.8 (1.6)
(1 phase)	Locked rotor amps each (total)	2.4 (4.8)	2.4 (4.8)

NOTE - Extremes of operating range are plus and minus 10% of line voltage.

¹ Field provided charge with 7.6 m (25 ft.) line set. Refer to the Lennox Refrigerant Piping Manual to determine refrigerant charge required with longer length refrigerant lines.

² Heating Air-Conditioning Refrigeration type breaker or fuse.

³ Refer to local codes to determine wire, fuse and disconnect size requirements.

SPECIFICATIONS

44 kW | 70 kW

General Data		Model Number	ELS150S4D	ELS180S4D	ELS240S4D
Connections (sweat)		Nominal Size - kW	44.0	53.0	70.0
Connections (sweat)	Liquid line - in. (o.d)		(2) 3/8	(2) 5/8	(2) 5/8
	Suction line - in. (o.d)		(2) 1-1/8	(2) 1-1/8	(2) 1-1/8
Refrigerant (R-410A)	Factory Charge		R-410A holding charge - 0.9 kg (2 lbs.) per circuit)		
	No. of Circuits		2	2	2
	¹ Field charge 7.6 m (25 ft.) line set	Circuit 1	6.8 kg (15 lbs. 0 oz.) (includes holding charge)	10.9 kg (24 lbs. 0 oz.) (includes holding charge)	10.1 kg (22 lbs. 4 oz.) (includes holding charge)
		Circuit 2	6.8 kg (15 lbs. 0 oz.) (includes holding charge)	10.9 kg (24 lbs. 0 oz.) (includes holding charge)	10.5 kg (23 lbs. 3 oz.) (includes holding charge)
Compressor			(2) Single Stage Scroll	(2) Single Stage Scroll	(2) Single Stage Scroll
Condenser Coil	Net face area - m ² (sq. ft.)	Outer coil	3.18 (34.2)	5.45 (58.7)	5.45 (58.7)
		Inner coil	3.09 (33.3)	5.36 (57.7)	5.36 (57.7)
	Tube diameter - mm (in.) & no. of rows		9.5 (3/8) - 2	9.5 (3/8) - 2	9.5 (3/8) - 2
		Fins per m (inch)	787 (20)	787 (20)	787 (20)
Condenser Fan(s)	Diameter - mm (in.) & number of blades		(2) 610 (24) - 4	(4) 610(24) - 3	(4) 610 (24) - 3
	Nominal Motor - Number and W (hp)		(2) 373 (1/2)	(4) 249 (1/3)	(4) 249 (1/3)
	Total air volume - L/s (cfm)		4060 (8600)	6515 (13800)	6515 (13800)
	Rev/min		900	900	900
	Watts		860	1270	1270

ELECTRICAL DATA

Line voltage data - 50 hz - 3 phase		380/420V	380/420V	380/420V
² Maximum Overcurrent Protection (amps)		25	40	50
³ Minimum circuit ampacity		21	31	36
Compressor	Number of Compressors	2	2	2
	Rated load amps each (total)	8.2 (16.4)	12.2 (24.4)	14.7 (29.4)
		Locked rotor amps each (total)	66 (132)	100 (200)
Condenser Fan Motor (1 phase)	No. of motors	2	4	4
	Full load amps each (total)	1.5 (3)	0.8 (3.2)	0.8 (3.2)
	Locked rotor amps each (total)	3 (6)	2.4 (9.6)	2.4 (9.6)

NOTE - Extremes of operating range are plus and minus 10% of line voltage.

¹ Field provided charge with 7.6 m (25 ft.) line set. Refer to the Lennox Refrigerant Piping Manual to determine refrigerant charge required with longer length refrigerant lines.

² Heating Air-Conditioning Refrigeration type breaker or fuse.

³ Refer to local codes to determine wire, fuse and disconnect size requirements.

WEIGHT DATA

Model No.	Net		Shipping	
	kg	lbs.	kg	lbs.
072S4S	144	318	153	338
090S4S	157	345	166	365
120S4S	205	452	216	477
120S4D	218	480	229	505
150S4D	243	535	254	560
180S4D	352	775	363	800
240S4D	377	832	389	857

OPTIONS / ACCESSORIES

COMBINED COIL/HAIL GUARDS

T2GARD20L-1	18	40	20	45
T2GARD20M-1	20	45	23	50
T2GARD21M-1	20	45	23	50
T2GARD20N-1-	41	90	45	100

OPTIONS / ACCESSORIES

Item	Catalog No.	ELS	ELS	ELS	ELS	ELS	ELS	ELS
		072 S4S	090 S4S	120 S4S	120 S4D	150 S4D	180 S4D	240 S4D
CABINET								
Combined Coil/Hail Guards	T2GARD51L-1	13T29	X	X				
	T2GARD51M11	13T30			X	X		
	T2GARD51M21	13T32					X	
	T2GARD51N-1	13T37					X	X
Corrosion Protection	Factory	O	O	O	O	O	O	O

CONTROLS

BACnet® Module	A0CTRL31LS1	17A08	X	X	X	X	X	X	X
BACnet® Sensor with Display	K0SNSR01FF1	97W23	X	X	X	X	X	X	X
BACnet® Sensor without Display	K0SNSR00FF1	97W24	X	X	X	X	X	X	X
Low Ambient Control (17.7°C)	A2CWKT01LM1-	16F18	X	X					
	A2CWKT04M-1-	16F26			X				
	A2CWKT02M-1-	16F24				X	X		
	A2CWKT03N-1-	16F25						X	X
Furnace Twinning Panel		Y3653	X	X	X	X	X	X	X

INDOOR AIR QUALITY

Sensor - Wall-mount, off-white plastic cover with LCD display	C0SNSR50AE1L	77N39	X	X	X	X	X	X	X
Sensor - Wall-mount, off-white plastic cover, no display	C0SNSR52AE1L	87N53	X	X	X	X	X	X	X
Sensor - Black plastic case with LCD display, rated for plenum mounting	C0SNSR51AE1L	87N52	X	X	X	X	X	X	X
Sensor - Wall-mount, black plastic case, no display, rated for plenum mounting	C0SNSR53AE1L	87N54	X	X	X	X	X	X	X
CO ₂ Sensor Duct Mounting Kit	C0MISC19AE1-	85L43	X	X	X	X	X	X	X
Aspiration Box - for duct mounting non-plenum rated CO ₂ sensor (77N39)	C0MISC16AE1-	90N43	X	X	X	X	X	X	X

NOTE - The catalog and model numbers that appear here are for ordering field installed accessories only.

O - Factory Installed with extended lead time.

X - Field Installed

SOUND DATA

¹ Unit Model No.	Octave Band Linear Sound Power Levels dB, re 10 ⁻¹² Watts Center Frequency - HZ							¹ Sound Rating Number (dB)
	125	250	500	1000	2000	4000	8000	
ELS072S4S	65	68	73	76	72	68	63	81
ELS090S4S	64	69	73	77	74	70	63	81
ELS120S4S	70	77	82	81	77	75	71	86
ELS120S4D	71	77	80	80	77	72	67	85
ELS150S4D	68	77	80	82	78	73	65	86
ELS180S4D	73	80	83	83	79	74	66	88
ELS240S4D	73	80	85	84	80	78	74	89

NOTE - the octave sound power data does not include tonal correction.

¹ Tested according to AHRI Standard 270 test conditions.

SYSTEM MATCHES
ONE OUTDOOR UNIT + ONE INDOOR UNIT

Model Number	1 Net Cooling Capacity		1 Coefficient of Performance (Output/Input)	1 Energy Efficiency Ratio at 35°C (Btuh/Watt)	2 Energy Efficiency Ratio at 46°C (Btuh/Watt)	Air Handler	Expansion Device
	kW	Btuh					
ELS072S4S	18.7	63 700	3.8	13.1	9.4	ELA072S4S	Factory TXV
ELS072S4S	19.0	65 000	3.4	11.6	8.6	ELA090S4D	Factory TXV
ELS090S4S	23.4	80 000	3.3	11.4	8.4	ELA120S4D	Factory TXV
ELS090S4S	23.5	80 200	3.4	11.6	8.8	ELA090S4D	Factory TXV
ELS120S4S	30.5	104 000	3.5	12.1	9.0	ELA120S4D	Factory TXV
ELS120S4D	29.4	100 400	3.4	11.5	8.4	ELA120S4D	Factory TXV
ELS150S4D	34.6	117 900	3.3	11.2	8.0	ELA150S4D	Factory TXV
ELS150S4D	35.8	122 000	3.3	11.4	8.3	ELA180S4D	Factory TXV
ELS180S4D	46.0	156 900	3.3	11.3	8.2	ELA180S4D	Factory TXV
ELS180S4D	48.6	166 000	3.3	11.2	8.2	ELA240S4D	Factory TXV
ELS240S4D	58.9	201 000	3.3	11.1	8.3	ELA240S4D	Factory TXV

NOTE - Net capacity includes indoor blower motor heat deduction. Gross capacity does not include indoor blower motor heat deduction.

¹ Rating test conditions are those included in Air-Conditioning, Heating and Refrigeration Institute (AHRI) Standard 340/360;35°C (95°F) outdoor air temperature and 27°C (80°F) db/19°C (67°F) wb entering evaporator air; minimum external duct static pressure while operating at rated voltage and air volumes.

² Rated at 46°C (115°F) outdoor air temperature and 27°C (80°F) db/19°C (67°F) wb entering evaporator air (T3 Conditions)

SYSTEM MATCHES
ONE OUTDOOR UNIT + TWO INDOOR UNITS

Model Number	1 Net Cooling Capacity		1 Coefficient of Performance (Output/Input)	1 Energy Efficiency Ratio at 35°C (Btuh/Watt)	2 Energy Efficiency Ratio at 46°C (Btuh/Watt)	Air Handler	Expansion Device
	kW	Btuh					
ELS090S4S	24.0	82 000	3.3	11.3	8.2	(2) CX35-60D	Factory TXV
ELS090S4S	24.8	84 500	3.3	11.4	8.3	(2) CX35-60C	Factory TXV
ELS120S4D	27.7	94 600	3.2	10.9	8.0	(2) CH33-62D	12J20 (Order 2)
ELS120S4D	28.2	96 200	3.3	11.1	8.1	(2) CH23-68	12J20 (Order 2)
ELS120S4D	28.2	96 200	3.3	11.1	8.1	(2) CX35-60D	Factory TXV
ELS120S4D	28.3	96 400	3.3	11.2	8.1	(2) CX35-60C	Factory TXV
ELS180S4D	45.7	156 000	3.3	11.3	8.2	(2) ELA090S4D	Factory TXV
ELS240S4D	58.9	201 000	3.3	11.2	8.2	(2) ELA120S4D	Factory TXV

NOTE - Net capacity includes indoor blower motor heat deduction. Gross capacity does not include indoor blower motor heat deduction.

¹ Rating test conditions are those included in Air-Conditioning, Heating and Refrigeration Institute (AHRI) Standard 340/360;35°C (95°F) outdoor air temperature and 27°C (80°F) db/19°C (67°F) wb entering evaporator air; minimum external duct static pressure while operating at rated voltage and air volumes.

² Rated at 46°C (115°F) outdoor air temperature and 27°C (80°F) db/19°C (67°F) wb entering evaporator air (T3 Conditions)

SYSTEM MATCHES
TWO OUTDOOR UNITS + ONE INDOOR UNITS

Model Number	1 Net Cooling Capacity		1 Coefficient of Performance (Output/Input)	1 Energy Efficiency Ratio at 35°C (Btuh/Watt)	2 Energy Efficiency Ratio at 46°C (Btuh/Watt)	Air Handler	Expansion Device
	kW	Btuh					
(2) ELS090S4S	45.1	154 000	3.3	11.4	8.3	ELA180S4D	Factory TXV
(2) ELS120S4S	58.9	201 000	3.3	11.1	8.1	ELA240S4D	Factory TXV

NOTE - Net capacity includes indoor blower motor heat deduction. Gross capacity does not include indoor blower motor heat deduction.

¹ Rating test conditions are those included in Air-Conditioning, Heating and Refrigeration Institute (AHRI) Standard 340/360;35°C (95°F) outdoor air temperature and 27°C (80°F) db/19°C (67°F) wb entering evaporator air; minimum external duct static pressure while operating at rated voltage and air volumes.

² Rated at 46°C (115°F) outdoor air temperature and 27°C (80°F) db/19°C (67°F) wb entering evaporator air (T3 Conditions)

UNIT CLEARANCES

ELS072 and ELS090

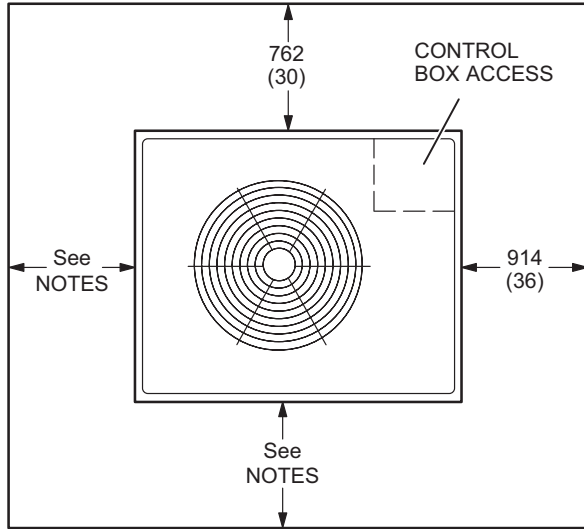

NOTES:

Clearance to one of the remaining two sides may be 305 mm (12 in.) and the final side may be 152 mm (6 in.).

A clearance of 610 mm (24 in.) must be maintained between two units.

1219 mm (48 in.) clearance required on top of unit.

ELS120 and ELS150

NOTES:

Clearance to one of the remaining two sides may be 305 mm (12 in.) and the final side may be 152 mm (6 in.).

A clearance of 610 mm (24 in.) must be maintained between two units.

1219 mm (48 in.) clearance required on top of unit.

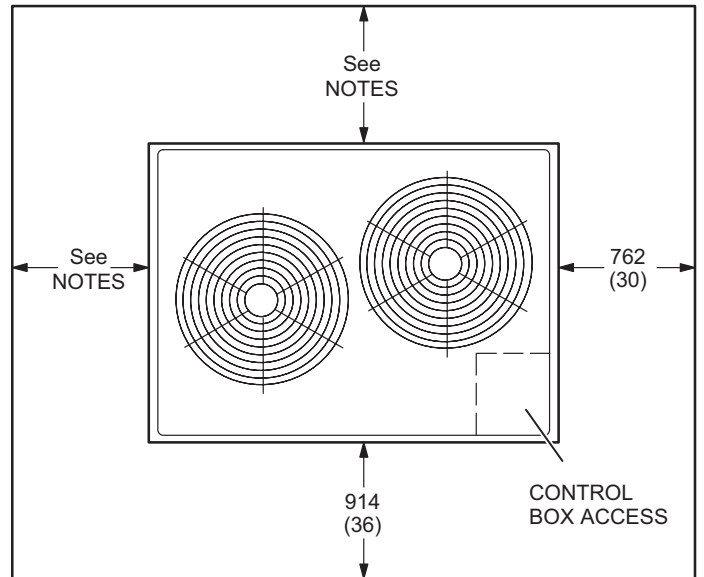

ELS180 and ELS240

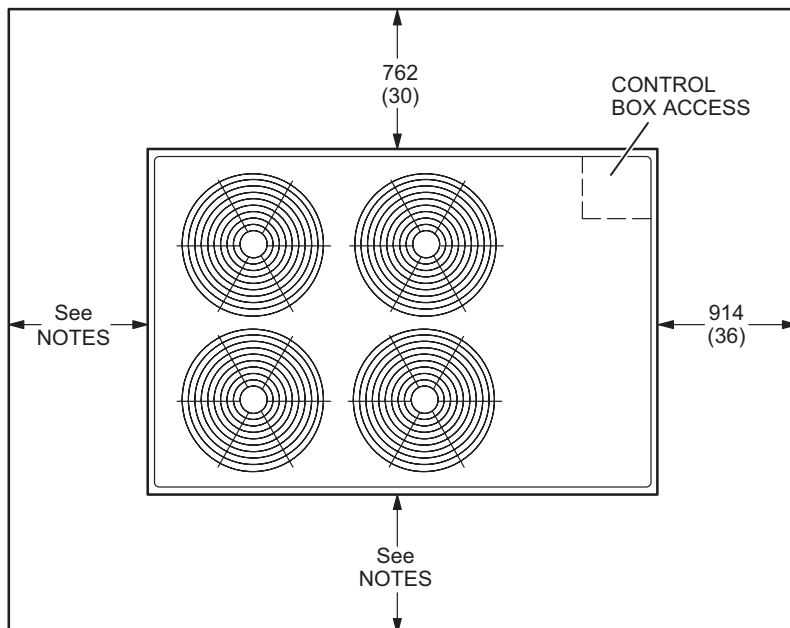

NOTES:

Clearance to one of the remaining two sides may be 305 mm (12 in.) and the final side may be 152 mm (6 in.).

A clearance of 610 mm (24 in.) must be maintained between two units.

1219 mm (48 in.) clearance required on top of unit.

DIMENSIONS

ELS072 AND ELS090

Model Number	CORNER WEIGHTS								CENTER OF GRAVITY			
	AA		BB		CC		DD		EE		FF	
	kg	lbs.	kg	lbs.	kg	lbs.	kg	lbs.	mm	in.	mm	in.
ELS072S4S	30	66	33	73	44	97	37	82	591	23-1/4	489	19-1/4
ELS090S4S	34	75	40	89	51	112	40	88	635	25	514	20-1/4

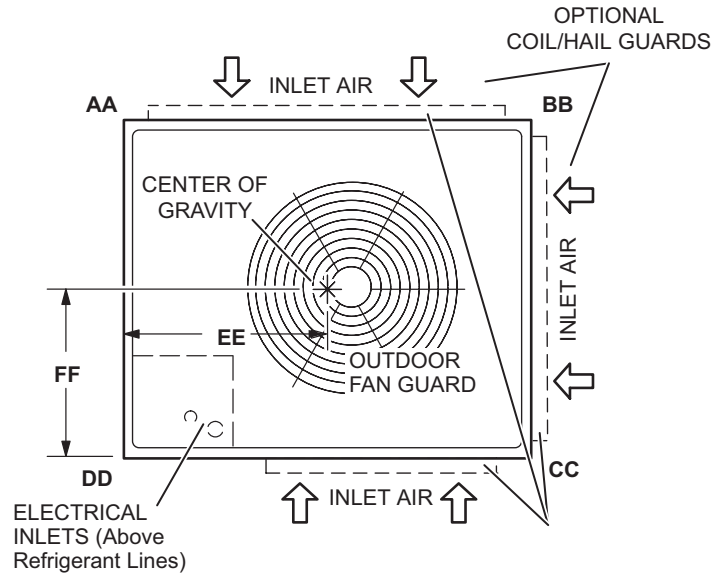
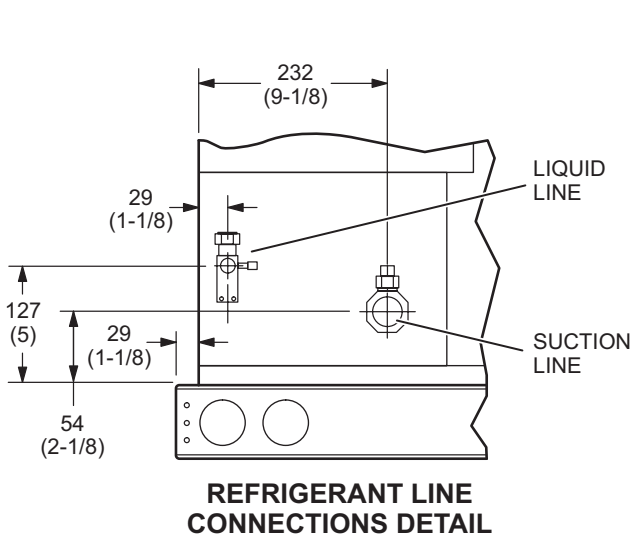

TOP VIEW

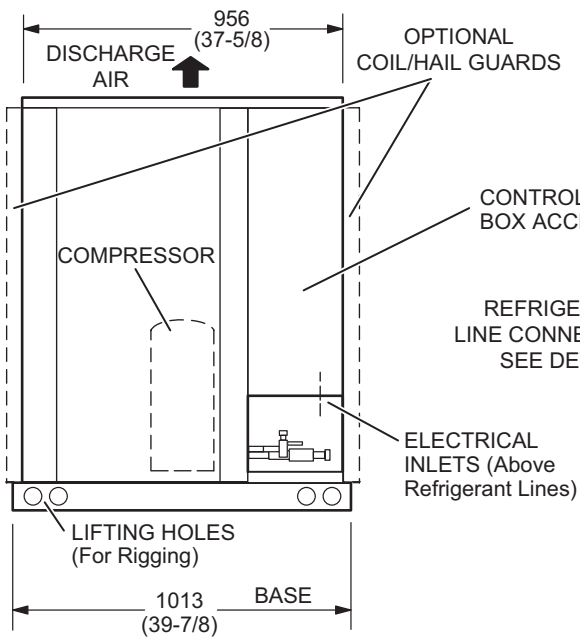

FRONT VIEW

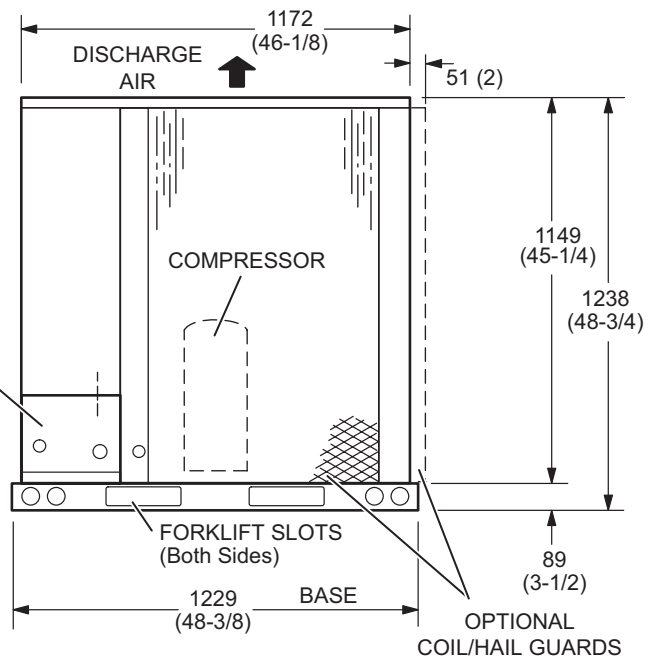

SIDE VIEW

DIMENSIONS

ELS120 AND ELS150

Model Number	CORNER WEIGHTS								CENTER OF GRAVITY			
	AA		BB		CC		DD		EE		FF	
	kg	lbs.	kg	lbs.	kg	lbs.	kg	lbs.	mm	in.	mm	in.
ELS120S4S	59	130	56	124	49	107	50	111	521	20-1/2	851	33-1/2
ELS120S4D	55	122	54	119	58	127	59	131	533	21	724	28-1/2
ELS150S4D	66	144	60	132	60	133	66	145	483	19	762	30

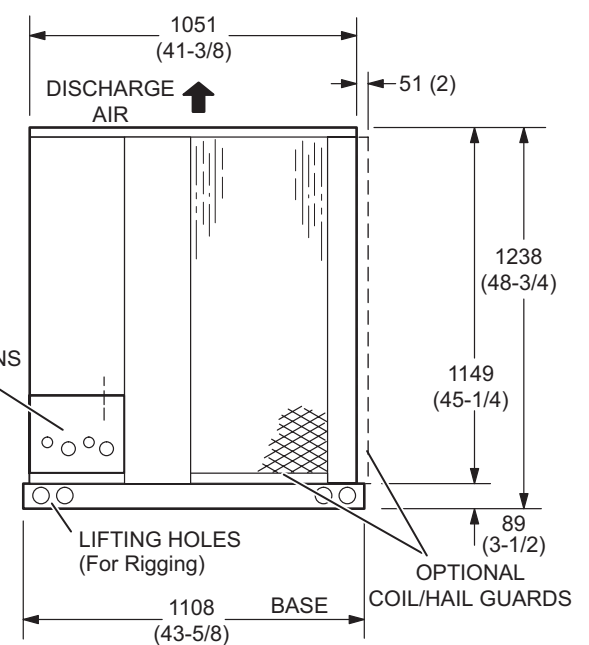
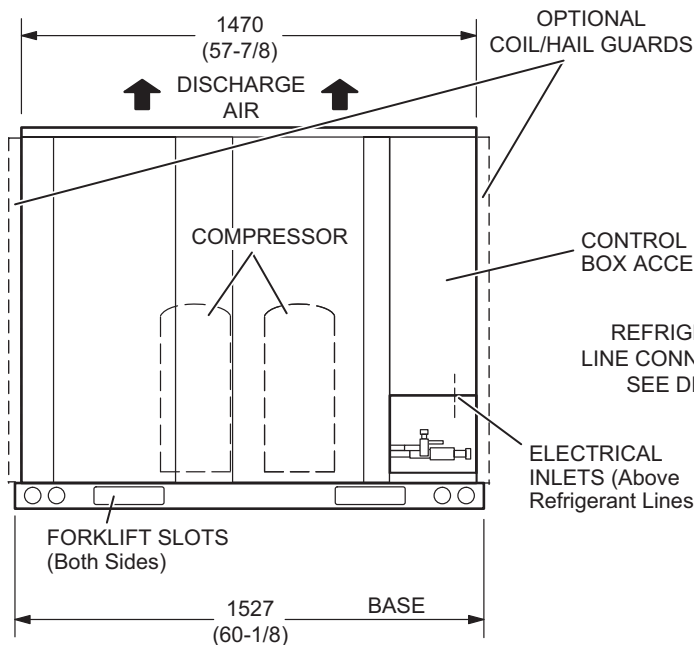
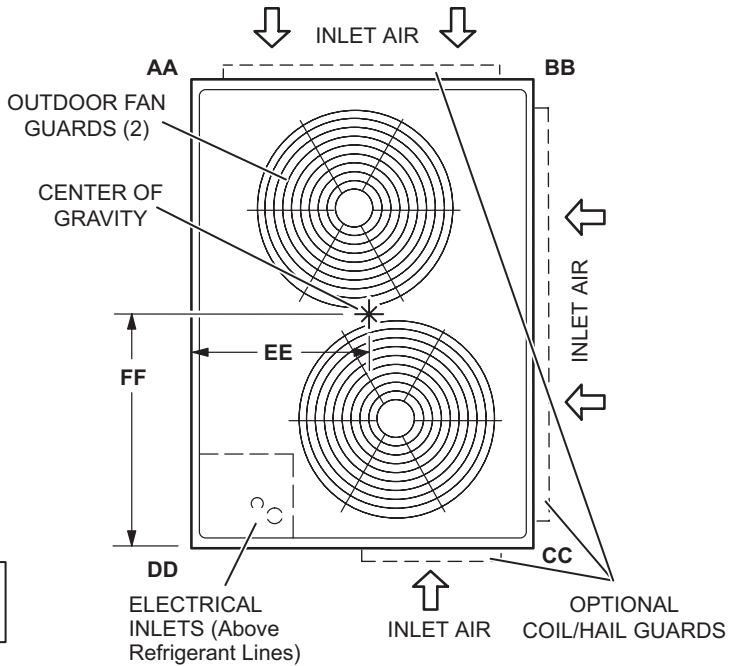
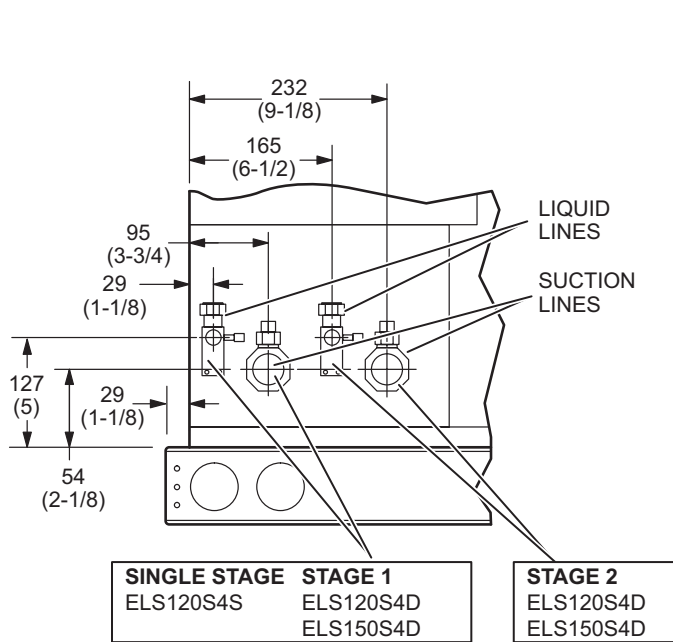

DIMENSIONS

ELS180 AND ELS240

Model Number	CORNER WEIGHTS								CENTER OF GRAVITY			
	AA		BB		CC		DD		EE		FF	
	kg	lbs.	kg	lbs.	kg	lbs.	kg	lbs.	mm	in.	mm	in.
ELS180S4D	82	181	81	177	98	215	100	221	737	29	965	38
ELS240S4D	87	192	86	189	105	232	108	238	737	29	953	37-1/2

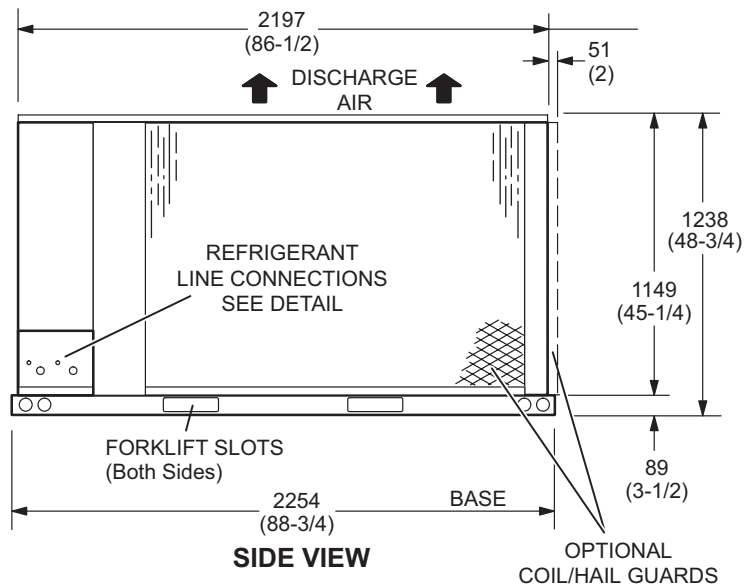
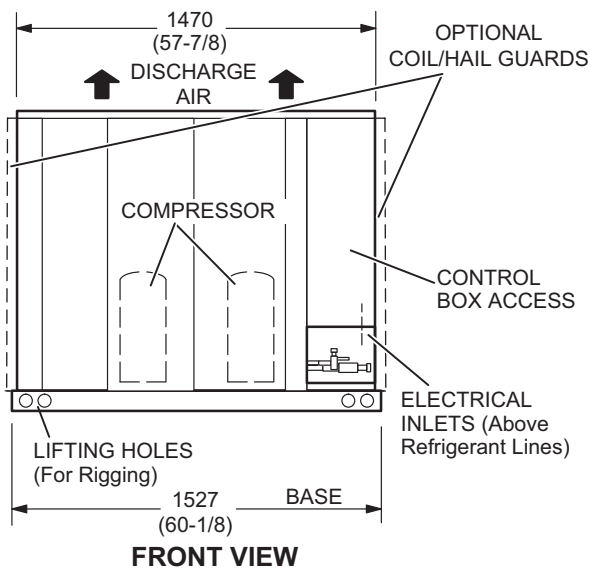
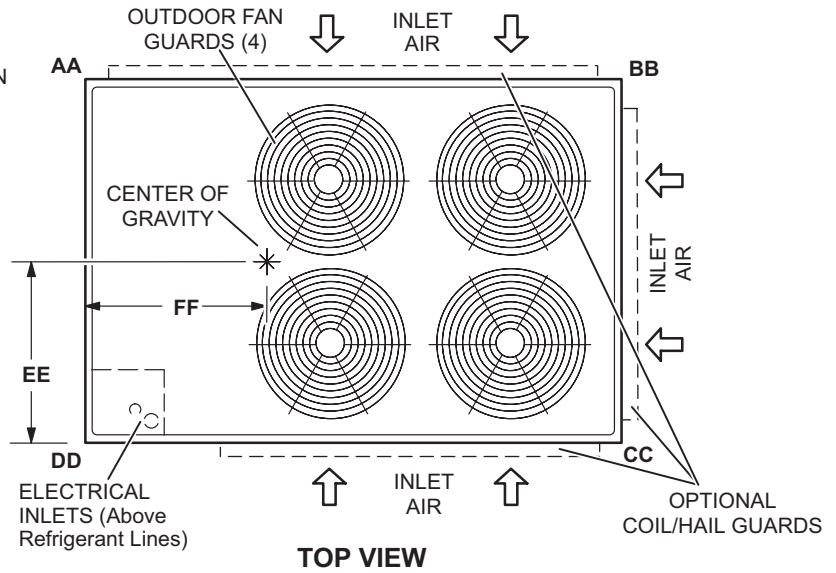
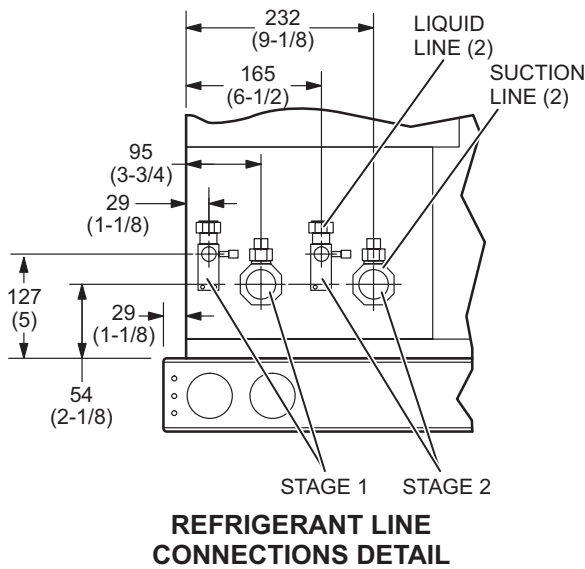

RATINGS

ONE OUTDOOR UNIT + ONE INDOOR UNIT

NOTE - For Temperatures and Capacities not shown in tables, see bulletin - Cooling Unit Rating Table Correction Factor Data in Miscellaneous Engineering Data section.

ELS072S4S + ELA072S4S (1ST STAGE)

Entering Wet Bulb Temperature	Total Air Volume	Outdoor Air Temperature Entering Outdoor Coil																			
		18.3°C					23.9°C					29.4°C					35°C				
		Total Cool Cap.	Comp. Motor Input	Sensible To Total Ratio (S/T)			Total Cool Cap.	Comp. Motor Input	Sensible To Total Ratio (S/T)			Total Cool Cap.	Comp. Motor Input	Sensible To Total Ratio (S/T)			Total Cool Cap.	Comp. Motor Input	Sensible To Total Ratio (S/T)		
				Dry Bulb					Dry Bulb					Dry Bulb					Dry Bulb		
		L/s	kW	kW	24°C	27°C	29°C	kW	kW	24°C	27°C	29°C	kW	kW	24°C	27°C	29°C	kW	kW	24°C	27°C
17.2°C	605	14	1.66	0.71	0.84	0.98	13.3	1.95	0.72	0.87	1	12.5	2.28	0.74	0.9	1	11.7	2.65	0.76	0.94	1
	755	14.9	1.65	0.75	0.92	1	14.1	1.95	0.77	0.95	1	13.2	2.28	0.79	0.98	1	12.4	2.64	0.83	1	1
	905	15.5	1.64	0.8	0.98	1	14.7	1.94	0.82	1	1	14	2.27	0.85	1	1	13.1	2.64	0.89	1	1
19.4°C	605	15	1.65	0.56	0.68	0.8	14.3	1.95	0.57	0.69	0.82	13.5	2.28	0.58	0.71	0.85	12.6	2.65	0.59	0.73	0.89
	755	15.9	1.64	0.59	0.72	0.87	15.1	1.94	0.6	0.74	0.9	14.2	2.27	0.61	0.76	0.94	13.3	2.64	0.63	0.79	0.98
	905	16.5	1.63	0.61	0.77	0.94	15.7	1.93	0.62	0.79	0.97	14.8	2.27	0.64	0.82	1	13.7	2.64	0.66	0.86	1
21.7°C	605	16	1.64	0.43	0.54	0.65	15.2	1.94	0.43	0.55	0.67	14.4	2.27	0.43	0.56	0.68	13.5	2.64	0.44	0.57	0.71
	755	16.9	1.63	0.44	0.57	0.7	16.1	1.93	0.44	0.58	0.72	15.2	2.27	0.45	0.59	0.74	14.2	2.64	0.45	0.61	0.76
	905	17.6	1.62	0.45	0.6	0.74	16.7	1.93	0.45	0.61	0.76	15.8	2.26	0.46	0.63	0.79	14.7	2.63	0.47	0.65	0.82

ELS072S4S + ELA072S4S (2ND STAGE)

Entering Wet Bulb Temperature	Total Air Volume	Outdoor Air Temperature Entering Outdoor Coil																			
		26.7°C					35°C					43.3°C					46°C				
		Total Cool Cap.	Comp. Motor Input	Sensible To Total Ratio (S/T)			Total Cool Cap.	Comp. Motor Input	Sensible To Total Ratio (S/T)			Total Cool Cap.	Comp. Motor Input	Sensible To Total Ratio (S/T)			Total Cool Cap.	Comp. Motor Input	Sensible To Total Ratio (S/T)		
				Dry Bulb					Dry Bulb					Dry Bulb					Dry Bulb		
		L/s	kW	kW	24°C	27°C	29°C	kW	kW	24°C	27°C	29°C	kW	kW	24°C	27°C	29°C	kW	kW	24°C	27°C
17.2°C	905	18.5	3.21	0.76	0.91	1.00	17.3	3.88	0.78	0.94	1.00	15.9	4.70	0.81	0.97	1.00	15.5	5.18	0.82	0.99	1.00
	1135	19.4	3.24	0.82	0.97	1.00	18.1	3.92	0.84	1.00	1.00	16.8	4.74	0.88	1.00	1.00	16.4	5.21	0.90	1.00	1.00
	1360	20.1	3.27	0.87	1.00	1.00	18.9	3.95	0.90	1.00	1.00	17.6	4.77	0.94	1.00	1.00	17.2	5.24	0.96	1.00	1.00
19.4°C	905	19.6	3.25	0.60	0.74	0.87	18.3	3.92	0.61	0.76	0.90	17.0	4.75	0.63	0.79	0.94	16.5	5.22	0.63	0.80	0.96
	1135	20.5	3.28	0.63	0.79	0.94	19.1	3.96	0.65	0.82	0.98	17.6	4.78	0.67	0.86	1.00	17.1	5.24	0.68	0.87	1.00
	1360	21.2	3.31	0.67	0.85	1.00	19.7	3.98	0.69	0.88	1.00	18.1	4.79	0.71	0.92	1.00	17.6	5.26	0.72	0.94	1.00
21.7°C	905	20.7	3.29	0.45	0.58	0.71	19.4	3.96	0.46	0.60	0.73	18.0	4.79	0.46	0.62	0.76	17.5	5.25	0.46	0.62	0.77
	1135	21.7	3.33	0.46	0.62	0.77	20.3	4.01	0.47	0.64	0.80	18.7	4.83	0.48	0.66	0.83	18.2	5.29	0.48	0.67	0.85
	1360	22.4	3.36	0.48	0.65	0.82	20.9	4.03	0.49	0.68	0.86	19.2	4.85	0.50	0.70	0.90	18.6	5.30	0.50	0.71	0.91

Entering Wet Bulb Temperature	Total Air Volume	Outdoor Air Temperature Entering Outdoor Coil																	
		48°C					50°C					51.7°C							
		Total Cool Cap.	Comp. Motor Input	Sensible To Total Ratio (S/T)			Total Cool Cap.	Comp. Motor Input	Sensible To Total Ratio (S/T)			Total Cool Cap.	Comp. Motor Input	Sensible To Total Ratio (S/T)					
				Dry Bulb					Dry Bulb					Dry Bulb					
		L/s	kW	kW	24°C	27°C	29°C	kW	kW	24°C	27°C	29°C	kW	kW	24°C	27°C	29°C		
17.2°C	905	15.2	5.43	0.83	0.99	1.00	14.7	5.69	0.85	1.00	1.00	14.5	5.69	0.86	1.00	1.00			
	1135	16.1	5.46	0.91	1.00	1.00	15.7	5.73	0.92	1.00	1.00	15.4	5.73	0.93	1.00	1.00			
	1360	16.9	5.49	0.97	1.00	1.00	16.5	5.75	0.98	1.00	1.00	16.1	5.76	0.99	1.00	1.00			
19.4°C	905	16.1	5.46	0.64	0.81	0.97	15.7	5.73	0.65	0.82	0.98	15.3	5.72	0.65	0.83	0.99			
	1135	16.7	5.49	0.68	0.88	1.00	16.3	5.75	0.69	0.90	1.00	15.9	5.76	0.70	0.91	1.00			
	1360	17.1	5.50	0.73	0.95	1.00	16.7	5.75	0.74	0.96	1.00	16.3	5.77	0.75	0.97	1.00			
21.7°C	905	17.1	5.50	0.47	0.63	0.78	16.7	5.75	0.47	0.63	0.79	16.3	5.78	0.47	0.64	0.80			
	1135	17.7	5.52	0.49	0.67	0.86	17.3	5.78	0.49	0.68	0.87	16.9	5.81	0.49	0.69	0.88			
	1360	18.2	5.54	0.51	0.72	0.92	17.8	5.80	0.51	0.73	0.94	17.4	5.84	0.52	0.74	0.95			

RATINGS

ONE OUTDOOR UNIT + ONE INDOOR UNIT

NOTE - For Temperatures and Capacities not shown in tables, see bulletin - Cooling Unit Rating Table Correction Factor Data in Miscellaneous Engineering Data section.

ELS072S4S + ELA090S4D (1ST STAGE)

Entering Wet Bulb Temperature	Total Air Volume	Outdoor Air Temperature Entering Outdoor Coil																							
		18.3 °C						23.9 °C						29.4 °C						35 °C					
		Total Cool Cap.	Comp. Motor Input	Sensible To Total Ratio (S/T)			Total Cool Cap.	Comp. Motor Input	Sensible To Total Ratio (S/T)			Total Cool Cap.	Comp. Motor Input	Sensible To Total Ratio (S/T)			Total Cool Cap.	Comp. Motor Input	Sensible To Total Ratio (S/T)						
				Dry Bulb					Dry Bulb					Dry Bulb					Dry Bulb						
L/s	kW	kW	24°C	27°C	29°C	kW	kW	24°C	27°C	29°C	kW	kW	24°C	27°C	29°C	kW	kW	24°C	27°C	29°C					
17.2°C	604	14.8	1.75	0.71	0.84	0.99	14	2.06	0.72	0.87	1	13.2	2.41	0.74	0.9	1	12.3	2.8	0.77	0.94	1				
	755	15.6	1.74	0.76	0.92	1	14.8	2.06	0.78	0.96	1	13.9	2.41	0.8	0.99	1	13.1	2.8	0.83	1	1				
	906	16.3	1.73	0.81	0.99	1	15.5	2.05	0.83	1	1	14.8	2.4	0.87	1	1	14	2.79	0.9	1	1				
19.4°C	604	15.9	1.74	0.56	0.68	0.8	15.1	2.06	0.57	0.69	0.82	14.2	2.41	0.58	0.71	0.85	13.3	2.8	0.59	0.74	0.89				
	755	16.8	1.73	0.59	0.73	0.88	15.9	2.05	0.6	0.75	0.91	15	2.4	0.61	0.77	0.94	14	2.79	0.63	0.8	0.98				
	906	17.4	1.72	0.61	0.77	0.95	16.5	2.05	0.63	0.8	0.98	15.5	2.4	0.65	0.83	1	14.4	2.79	0.67	0.87	1				
21.7°C	604	17	1.73	0.43	0.54	0.66	16.2	2.05	0.43	0.55	0.67	15.3	2.4	0.43	0.56	0.68	14.3	2.79	0.44	0.57	0.71				
	755	17.9	1.72	0.44	0.57	0.7	17.1	2.04	0.44	0.58	0.72	16.1	2.4	0.45	0.6	0.74	15.1	2.79	0.45	0.61	0.77				
	906	18.5	1.71	0.45	0.6	0.75	17.7	2.04	0.45	0.61	0.77	16.7	2.4	0.46	0.63	0.8	15.6	2.79	0.47	0.65	0.83				

ELS072S4S + ELA090S4D (2ND STAGE)

Entering Wet Bulb Temperature	Total Air Volume	Outdoor Air Temperature Entering Outdoor Coil																							
		26.7 °C						35 °C						43.3 °C						46 °C					
		Total Cool Cap.	Comp. Motor Input	Sensible To Total Ratio (S/T)			Total Cool Cap.	Comp. Motor Input	Sensible To Total Ratio (S/T)			Total Cool Cap.	Comp. Motor Input	Sensible To Total Ratio (S/T)			Total Cool Cap.	Comp. Motor Input	Sensible To Total Ratio (S/T)						
				Dry Bulb					Dry Bulb					Dry Bulb					Dry Bulb						
L/s	kW	kW	24°C	27°C	29°C	kW	kW	24°C	27°C	29°C	kW	kW	24°C	27°C	29°C	kW	kW	24°C	27°C	29°C					
17.2°C	905	19.1	3.25	0.76	0.91	1	17.8	3.93	0.79	0.94	1	16.5	4.75	0.82	0.98	1	16.0	5.05	0.83	0.99	1.00				
	1135	20	3.28	0.83	0.99	1	18.7	3.96	0.85	1	1	17.5	4.8	0.89	1	1	17.1	5.10	0.90	1.00	1.00				
	1360	20.9	3.32	0.88	1	1	19.7	4	0.91	1	1	18.3	4.84	0.96	1	1	17.8	5.13	0.97	1.00	1.00				
19.4°C	905	20.3	3.29	0.6	0.74	0.88	18.9	3.97	0.61	0.76	0.91	17.5	4.8	0.63	0.79	0.95	16.9	5.09	0.64	0.80	0.96				
	1135	21.2	3.32	0.63	0.8	0.95	19.7	4	0.65	0.83	0.99	18.2	4.83	0.67	0.86	1	17.7	5.12	0.68	0.88	1.00				
	1360	21.7	3.35	0.67	0.86	1	20.3	4.03	0.69	0.89	1	18.7	4.86	0.71	0.93	1	18.2	5.16	0.73	0.95	1.00				
21.7°C	905	21.5	3.34	0.45	0.58	0.72	20.1	4.02	0.46	0.6	0.74	18.5	4.85	0.47	0.61	0.77	18.0	5.14	0.46	0.62	0.78				
	1135	22.3	3.38	0.46	0.62	0.77	20.9	4.06	0.47	0.65	0.8	19.3	4.88	0.48	0.66	0.84	18.7	5.18	0.48	0.67	0.85				
	1360	23	3.4	0.48	0.66	0.83	21.4	4.08	0.49	0.68	0.87	19.8	4.91	0.5	0.71	0.91	19.2	5.20	0.51	0.72	0.92				

Entering Wet Bulb Temperature	Total Air Volume	Outdoor Air Temperature Entering Outdoor Coil																	
		48 °C						50 °C						51.7 °C					
		Total Cool Cap.	Comp. Motor Input	Sensible To Total Ratio (S/T)			Total Cool Cap.	Comp. Motor Input	Sensible To Total Ratio (S/T)			Total Cool Cap.	Comp. Motor Input	Sensible To Total Ratio (S/T)					
				Dry Bulb					Dry Bulb					Dry Bulb					
L/s	kW	kW	24°C	27°C	29°C	kW	kW	24°C	27°C	29°C	kW	kW	24°C	27°C	29°C				
17.2°C	905	15.6	5.28	0.84	1.00	1.00	15.3	5.53	0.85	1.00	1.00	15.1	5.75	0.86	1	1			
	1135	16.7	5.33	0.91	1.00	1.00	16.4	5.58	0.93	1.00	1.00	16	5.79	0.94	1	1			
	1360	17.5	5.36	0.98	1.00	1.00	17.2	5.62	0.99	1.00	1.00	16.9	5.84	1	1	1			
19.4°C	905	16.6	5.32	0.64	0.81	0.97	16.2	5.56	0.65	0.82	0.98	15.9	5.78	0.65	0.83	0.99			
	1135	17.3	5.36	0.69	0.89	1.00	16.8	5.60	0.70	0.90	1.00	16.5	5.82	0.7	0.91	1			
	1360	17.8	5.39	0.73	0.96	1.00	17.3	5.62	0.75	0.97	1.00	17	5.85	0.75	0.98	1			
21.7°C	905	17.7	5.38	0.47	0.63	0.78	17.2	5.63	0.47	0.64	0.79	16.9	5.84	0.47	0.64	0.8			
	1135	18.3	5.41	0.48	0.68	0.86	17.9	5.65	0.49	0.69	0.88	17.5	5.87	0.49	0.69	0.89			
	1360	18.8	5.44	0.51	0.73	0.94	18.4	5.68	0.51	0.74	0.95	17.9	5.9	0.52	0.74	0.96			

RATINGS

ONE OUTDOOR UNIT + ONE INDOOR UNIT

NOTE - For Temperatures and Capacities not shown in tables, see bulletin - Cooling Unit Rating Table Correction Factor Data in Miscellaneous Engineering Data section.

ELS090S4S + ELA120S4D (1ST STAGE)

Entering Wet Bulb Temperature	Total Air Volume	Outdoor Air Temperature Entering Outdoor Coil																			
		18.3 °C					23.9 °C					29.4 °C					35 °C				
		Total Cool Cap.	Comp. Motor Input	Sensible To Total Ratio (S/T)			Total Cool Cap.	Comp. Motor Input	Sensible To Total Ratio (S/T)			Total Cool Cap.	Comp. Motor Input	Sensible To Total Ratio (S/T)			Total Cool Cap.	Comp. Motor Input	Sensible To Total Ratio (S/T)		
				Dry Bulb					Dry Bulb					Dry Bulb					Dry Bulb		
L/s	kW	kW	24°C	27°C	29°C	kW	kW	24°C	27°C	29°C	kW	kW	24°C	27°C	29°C	kW	kW	24°C	27°C	29°C	
17.2°C	755	16.5	2.26	0.75	0.89	1	15.7	2.65	0.76	0.91	1	14.9	3.08	0.78	0.94	1	14	3.57	0.8	0.97	1
	944	17.4	2.25	0.8	0.96	1	16.6	2.64	0.82	0.99	1	15.7	3.08	0.84	1	1	14.9	3.56	0.87	1	1
	1133	18.3	2.25	0.85	1	1	17.5	2.64	0.88	1	1	16.7	3.07	0.91	1	1	15.8	3.55	0.94	1	1
19.4°C	755	17.7	2.25	0.59	0.72	0.85	16.9	2.64	0.59	0.73	0.87	16	3.08	0.6	0.75	0.9	15	3.56	0.62	0.77	0.93
	944	18.6	2.25	0.62	0.77	0.92	17.7	2.64	0.63	0.79	0.95	16.8	3.07	0.65	0.82	0.98	15.7	3.55	0.66	0.85	1
	1133	19.4	2.24	0.65	0.82	0.99	18.4	2.63	0.65	0.85	1	17.4	3.07	0.68	0.88	1	16.3	3.55	0.7	0.91	1
21.7°C	755	18.8	2.24	0.42	0.56	0.69	18.1	2.64	0.45	0.58	0.7	17.1	3.07	0.45	0.58	0.72	16.2	3.55	0.46	0.6	0.74
	944	19.8	2.24	0.46	0.6	0.74	19	2.63	0.46	0.62	0.76	18	3.07	0.46	0.63	0.79	17	3.55	0.47	0.65	0.81
	1133	20.5	2.24	0.47	0.63	0.79	19.6	2.63	0.47	0.65	0.82	18.6	3.07	0.48	0.66	0.85	17.5	3.55	0.49	0.69	0.88

ELS090S4S + ELA120S4D (2ND STAGE)

Entering Wet Bulb Temperature	Total Air Volume	Outdoor Air Temperature Entering Outdoor Coil																			
		26.7 °C					35 °C					43.3 °C					46 °C				
		Total Cool Cap.	Comp. Motor Input	Sensible To Total Ratio (S/T)			Total Cool Cap.	Comp. Motor Input	Sensible To Total Ratio (S/T)			Total Cool Cap.	Comp. Motor Input	Sensible To Total Ratio (S/T)			Total Cool Cap.	Comp. Motor Input	Sensible To Total Ratio (S/T)		
				Dry Bulb					Dry Bulb					Dry Bulb					Dry Bulb		
L/s	kW	kW	24°C	27°C	29°C	kW	kW	24°C	27°C	29°C	kW	kW	24°C	27°C	29°C	kW	kW	24°C	27°C	29°C	
17.2°C	1135	23.9	4.73	0.76	0.91	1	22.4	5.48	0.79	0.94	1	20.5	6.35	0.82	0.99	1	20.0	6.66	0.83	1.00	1.00
	1415	25.1	4.81	0.83	0.99	1	23.6	5.58	0.85	1	1	21.9	6.47	0.89	1	1	21.4	6.79	0.90	1.00	1.00
	1700	26.4	4.9	0.88	1	1	24.8	5.67	0.91	1	1	23.1	6.57	0.96	1	1	22.4	6.88	0.97	1.00	1.00
19.4°C	1135	25.5	4.84	0.6	0.74	0.88	23.8	5.6	0.61	0.76	0.91	22	6.47	0.63	0.79	0.95	21.3	6.78	0.64	0.81	0.97
	1415	26.6	4.92	0.63	0.8	0.96	24.8	5.68	0.65	0.83	0.99	22.8	6.55	0.68	0.87	1	22.1	6.86	0.68	0.88	1.00
	1700	27.6	4.99	0.67	0.86	1	25.6	5.74	0.69	0.89	1	23.4	6.61	0.72	0.93	1	22.7	6.91	0.73	0.95	1.00
21.7°C	1135	27.1	4.96	0.44	0.58	0.71	25.4	5.72	0.45	0.6	0.74	23.4	6.6	0.46	0.61	0.77	22.7	6.90	0.46	0.62	0.78
	1415	28.3	5.05	0.46	0.62	0.78	26.4	5.81	0.47	0.64	0.8	24.3	6.68	0.48	0.67	0.84	23.5	6.99	0.48	0.68	0.85
	1700	29.2	5.11	0.48	0.65	0.83	27.1	5.87	0.49	0.68	0.87	24.9	6.74	0.5	0.71	0.91	24.1	7.03	0.50	0.72	0.93

Entering Wet Bulb Temperature	Total Air Volume	Outdoor Air Temperature Entering Outdoor Coil														
		48 °C					50 °C					51.7 °C				
		Total Cool Cap.	Comp. Motor Input	Sensible To Total Ratio (S/T)			Total Cool Cap.	Comp. Motor Input	Sensible To Total Ratio (S/T)			Total Cool Cap.	Comp. Motor Input	Sensible To Total Ratio (S/T)		
				Dry Bulb					Dry Bulb					Dry Bulb		
L/s	kW	kW	24°C	27°C	29°C	kW	kW	24°C	27°C	29°C	kW	kW	24°C	27°C	29°C	
17.2°C	1135	19.5	6.91	0.84	1.00	1.00	19.1	7.15	0.85	1.00	1.00	18.7	7.38	0.86	1	1
	1415	20.8	7.02	0.92	1.00	1.00	20.4	7.28	0.93	1.00	1.00	20	7.51	0.95	1	1
	1700	22.0	7.12	0.98	1.00	1.00	21.4	7.38	1.00	1.00	1.00	21	7.61	1	1	1
19.4°C	1135	20.7	7.02	0.64	0.82	0.98	20.2	7.26	0.65	0.83	0.99	19.8	7.49	0.66	0.84	1
	1415	21.6	7.09	0.68	0.89	1.00	21.0	7.35	0.70	0.90	1.00	20.5	7.56	0.7	0.91	1
	1700	22.2	7.15	0.74	0.96	1.00	21.7	7.40	0.74	0.98	1.00	21.1	7.62	0.75	0.99	1
21.7°C	1135	22.2	7.15	0.47	0.63	0.79	21.6	7.40	0.47	0.63	0.80	21.1	7.62	0.47	0.64	0.81
	1415	23.0	7.23	0.49	0.68	0.86	22.4	7.47	0.49	0.69	0.88	21.8	7.7	0.49	0.7	0.89
	1700	23.6	7.27	0.51	0.73	0.94	23.0	7.53	0.51	0.74	0.95	22.5	7.76	0.51	0.75	0.97

RATINGS

ONE OUTDOOR UNIT + ONE INDOOR UNIT

NOTE - For Temperatures and Capacities not shown in tables, see bulletin - Cooling Unit Rating Table Correction Factor Data in Miscellaneous Engineering Data section.

ELS090S4S + ELA090S4D (1ST STAGE)

Entering Wet Bulb Temperature	Total Air Volume	Outdoor Air Temperature Entering Outdoor Coil																			
		18.3 °C					23.9 °C					29.4 °C					35 °C				
		Total Cool Cap.	Comp. Motor Input	Sensible To Total Ratio (S/T)			Total Cool Cap.	Comp. Motor Input	Sensible To Total Ratio (S/T)			Total Cool Cap.	Comp. Motor Input	Sensible To Total Ratio (S/T)			Total Cool Cap.	Comp. Motor Input	Sensible To Total Ratio (S/T)		
				Dry Bulb					Dry Bulb					Dry Bulb					Dry Bulb		
L/s	kW	kW	24°C	27°C	29°C	kW	kW	24°C	27°C	29°C	kW	kW	24°C	27°C	29°C	kW	kW	24°C	27°C	29°C	
17.2°C	755	16.8	2.18	0.75	0.89	1	16	2.56	0.76	0.91	1	15.1	2.98	0.78	0.94	1	14.2	3.44	0.81	0.97	1
	945	17.8	2.18	0.8	0.96	1	16.9	2.55	0.82	0.99	1	16.1	2.97	0.85	1	1	15.2	3.43	0.88	1	1
	1135	18.6	2.17	0.85	1	1	17.8	2.55	0.88	1	1	17	2.97	0.91	1	1	16.1	3.43	0.94	1	1
19.4°C	755	18.1	2.17	0.58	0.72	0.85	17.2	2.55	0.6	0.74	0.87	16.3	2.97	0.61	0.75	0.9	15.4	3.43	0.62	0.78	0.93
	945	19	2.17	0.62	0.77	0.92	18.1	2.55	0.63	0.79	0.95	17.1	2.97	0.65	0.82	0.98	16.1	3.43	0.66	0.85	1
	1135	19.7	2.16	0.65	0.83	0.99	18.7	2.54	0.66	0.85	1	17.7	2.96	0.68	0.88	1	16.6	3.43	0.7	0.91	1
21.7°C	755	19.3	2.17	0.44	0.57	0.69	18.5	2.54	0.44	0.58	0.71	17.5	2.96	0.45	0.59	0.72	16.5	3.43	0.45	0.6	0.75
	945	20.3	2.16	0.45	0.6	0.74	19.4	2.54	0.46	0.62	0.76	18.4	2.96	0.47	0.63	0.79	17.3	3.42	0.47	0.65	0.82
	1135	21.1	2.16	0.47	0.64	0.8	20.1	2.54	0.48	0.65	0.83	19	2.96	0.48	0.67	0.85	17.8	3.42	0.49	0.69	0.88

ELS090S4S + ELA090S4D (2ND STAGE)

Entering Wet Bulb Temperature	Total Air Volume	Outdoor Air Temperature Entering Outdoor Coil																			
		26.7 °C					35 °C					43.3 °C					46 °C				
		Total Cool Cap.	Comp. Motor Input	Sensible To Total Ratio (S/T)			Total Cool Cap.	Comp. Motor Input	Sensible To Total Ratio (S/T)			Total Cool Cap.	Comp. Motor Input	Sensible To Total Ratio (S/T)			Total Cool Cap.	Comp. Motor Input	Sensible To Total Ratio (S/T)		
				Dry Bulb					Dry Bulb					Dry Bulb					Dry Bulb		
L/s	kW	kW	24°C	27°C	29°C	kW	kW	24°C	27°C	29°C	kW	kW	24°C	27°C	29°C	kW	kW	24°C	27°C	29°C	
17.2°C	1135	23.9	4.83	0.76	0.91	1.00	22.2	5.61	0.79	0.94	1.00	20.5	6.50	0.82	0.98	1.00	20.3	6.82	0.83	0.99	1.00
	1415	25.1	4.92	0.82	0.98	1.00	23.4	5.70	0.85	1.00	1.00	21.7	6.61	0.89	1.00	1.00	21.6	6.93	0.90	1.00	1.00
	1700	26.2	5.00	0.88	1.00	1.00	24.6	5.79	0.91	1.00	1.00	22.8	6.72	0.95	1.00	1.00	22.7	7.03	0.96	1.00	1.00
19.4°C	1135	25.4	4.94	0.60	0.74	0.87	23.7	5.72	0.61	0.76	0.91	21.8	6.62	0.63	0.79	0.95	21.5	6.93	0.64	0.80	0.96
	1415	26.5	5.03	0.63	0.79	0.95	24.7	5.81	0.65	0.83	0.98	22.7	6.70	0.68	0.86	1.00	22.5	7.01	0.68	0.88	1.00
	1700	27.4	5.10	0.67	0.85	1.00	25.5	5.87	0.69	0.89	1.00	23.4	6.76	0.71	0.93	1.00	23.1	7.07	0.73	0.94	1.00
21.7°C	1135	27.0	5.06	0.45	0.58	0.71	25.2	5.84	0.45	0.60	0.74	23.2	6.74	0.46	0.62	0.76	22.9	7.05	0.46	0.62	0.78
	1415	28.1	5.15	0.46	0.62	0.77	26.2	5.93	0.47	0.64	0.80	24.0	6.82	0.48	0.66	0.84	23.8	7.13	0.49	0.67	0.85
	1700	28.9	5.21	0.48	0.66	0.83	26.9	5.99	0.49	0.68	0.86	24.7	6.88	0.50	0.71	0.90	24.4	7.19	0.50	0.71	0.92

Entering Wet Bulb Temperature	Total Air Volume	Outdoor Air Temperature Entering Outdoor Coil														
		48 °C					50 °C					51.7 °C				
		Total Cool Cap.	Comp. Motor Input	Sensible To Total Ratio (S/T)			Total Cool Cap.	Comp. Motor Input	Sensible To Total Ratio (S/T)			Total Cool Cap.	Comp. Motor Input	Sensible To Total Ratio (S/T)		
				Dry Bulb					Dry Bulb					Dry Bulb		
L/s	kW	kW	24°C	27°C	29°C	kW	kW	24°C	27°C	29°C	kW	kW	24°C	27°C	29°C	
17.2°C	1135	19.8	7.07	0.84	1.00	1.00	19.4	7.34	0.85	1.00	1.00	18.7	7.56	0.86	1.00	1.00
	1415	21.2	7.19	0.91	1.00	1.00	20.7	7.45	0.93	1.00	1.00	19.9	7.68	0.94	1.00	1.00
	1700	22.2	7.28	0.98	1.00	1.00	21.7	7.55	0.98	1.00	1.00	20.9	7.77	0.99	1.00	1.00
19.4°C	1135	21.0	7.18	0.64	0.81	0.97	20.5	7.44	0.65	0.82	0.98	19.7	7.67	0.66	0.84	0.99
	1415	22.0	7.26	0.69	0.89	1.00	21.3	7.52	0.70	0.90	1.00	20.5	7.75	0.70	0.91	1.00
	1700	22.5	7.31	0.73	0.95	1.00	22.0	7.57	0.74	0.97	1.00	21.1	7.80	0.75	0.98	1.00
21.7°C	1135	22.4	7.31	0.47	0.63	0.79	21.8	7.56	0.47	0.64	0.80	21.0	7.79	0.48	0.64	0.81
	1415	23.2	7.39	0.49	0.68	0.86	22.7	7.64	0.49	0.69	0.87	21.7	7.87	0.49	0.69	0.88
	1700	23.9	7.45	0.50	0.73	0.93	23.2	7.69	0.51	0.74	0.94	22.3	7.92	0.52	0.74	0.95

RATINGS

ONE OUTDOOR UNIT + ONE INDOOR UNIT

NOTE - For Temperatures and Capacities not shown in tables, see bulletin - Cooling Unit Rating Table Correction Factor Data in Miscellaneous Engineering Data section.

ELS120S4S + ELA120S4D (1ST STAGE)

Entering Wet Bulb Temperature	Total Air Volume	Outdoor Air Temperature Entering Outdoor Coil																			
		18.3°C					23.9°C					29.4°C					35°C				
		Total Cool Cap.	Comp. Motor Input	Sensible To Total Ratio (S/T)			Total Cool Cap.	Comp. Motor Input	Sensible To Total Ratio (S/T)			Total Cool Cap.	Comp. Motor Input	Sensible To Total Ratio (S/T)			Total Cool Cap.	Comp. Motor Input	Sensible To Total Ratio (S/T)		
				Dry Bulb					Dry Bulb					Dry Bulb					Dry Bulb		
L/s	kW	kW	24°C	27°C	29°C	kW	kW	24°C	27°C	29°C	kW	kW	24°C	27°C	29°C	kW	kW	24°C	27°C	29°C	
17.2°C	1055	22.9	2.75	0.76	0.9	1	22	3.25	0.77	0.92	1	20.8	3.82	0.79	0.95	1	19.2	4.46	0.82	0.98	1
	1320	23.9	2.73	0.81	0.98	1	23.1	3.22	0.83	0.99	1	21.9	3.78	0.85	1	1	20.7	4.41	0.88	1	1
	1585	25	2.7	0.87	1	1	24.2	3.19	0.89	1	1	23.2	3.75	0.91	1	1	21.9	4.38	0.95	1	1
19.4°C	1055	24.3	2.72	0.6	0.73	0.87	23.4	3.21	0.6	0.74	0.88	22.2	3.78	0.61	0.76	0.91	20.7	4.42	0.62	0.78	0.94
	1320	25.3	2.7	0.63	0.79	0.95	24.5	3.18	0.63	0.8	0.96	23.2	3.75	0.65	0.82	0.99	21.7	4.39	0.67	0.85	1
	1585	26	2.69	0.67	0.85	1	25.2	3.17	0.67	0.87	1	24	3.73	0.69	0.88	1	22.4	4.36	0.7	0.92	1
21.7°C	1055	25.6	2.69	0.44	0.57	0.71	24.9	3.18	0.45	0.59	0.71	23.7	3.73	0.46	0.6	0.74	22.1	4.38	0.46	0.61	0.76
	1320	26.6	2.68	0.46	0.61	0.77	25.8	3.16	0.46	0.62	0.78	24.7	3.71	0.46	0.64	0.8	23.1	4.35	0.48	0.65	0.82
	1585	27.3	2.67	0.48	0.66	0.83	26.7	3.14	0.48	0.66	0.84	25.4	3.69	0.49	0.67	0.86	23.9	4.33	0.49	0.7	0.89

ELS120S4S + ELA120S4D (2ND STAGE)

Entering Wet Bulb Temperature	Total Air Volume	Outdoor Air Temperature Entering Outdoor Coil																			
		26.7°C					35°C					43.3°C					46°C				
		Total Cool Cap.	Comp. Motor Input	Sensible To Total Ratio (S/T)			Total Cool Cap.	Comp. Motor Input	Sensible To Total Ratio (S/T)			Total Cool Cap.	Comp. Motor Input	Sensible To Total Ratio (S/T)			Total Cool Cap.	Comp. Motor Input	Sensible To Total Ratio (S/T)		
				Dry Bulb					Dry Bulb					Dry Bulb					Dry Bulb		
L/s	kW	kW	24°C	27°C	29°C	kW	kW	24°C	27°C	29°C	kW	kW	24°C	27°C	29°C	kW	kW	24°C	27°C	29°C	
17.2°C	1510	30.7	5.76	0.77	0.91	1.00	28.8	6.74	0.79	0.94	1.00	26.3	7.94	0.82	0.98	1.00	25.4	8.70	0.83	1.00	1.00
	1890	32.1	5.82	0.82	0.98	1.00	30.1	6.80	0.85	1.00	1.00	28.0	8.03	0.89	1.00	1.00	27.0	8.79	0.90	1.00	1.00
	2265	33.5	5.88	0.87	1.00	1.00	31.7	6.89	0.91	1.00	1.00	29.3	8.10	0.95	1.00	1.00	28.2	8.85	0.97	1.00	1.00
19.4°C	1510	32.6	5.85	0.60	0.74	0.88	30.6	6.82	0.61	0.76	0.91	28.0	8.03	0.63	0.80	0.95	26.9	8.77	0.64	0.81	0.97
	1890	33.9	5.91	0.63	0.80	0.95	31.9	6.89	0.65	0.82	0.98	29.1	8.09	0.67	0.86	1.00	28.0	8.82	0.68	0.88	1.00
	2265	35.0	5.95	0.68	0.85	1.00	32.8	6.93	0.69	0.88	1.00	30.0	8.13	0.71	0.93	1.00	28.8	8.88	0.73	0.95	1.00
21.7°C	1510	34.6	5.94	0.45	0.58	0.72	32.5	6.92	0.45	0.59	0.73	29.8	8.11	0.46	0.62	0.77	28.6	8.87	0.47	0.62	0.78
	1890	36.0	6.00	0.47	0.62	0.77	33.8	6.99	0.47	0.64	0.80	30.9	8.17	0.48	0.67	0.84	29.7	8.93	0.48	0.67	0.85
	2265	37.0	6.05	0.48	0.66	0.83	34.7	7.03	0.49	0.67	0.86	31.8	8.21	0.50	0.71	0.90	30.5	8.98	0.51	0.72	0.92

Entering Wet Bulb Temperature	Total Air Volume	Outdoor Air Temperature Entering Outdoor Coil																	
		48°C					50°C					51.7°C							
		Total Cool Cap.	Comp. Motor Input	Sensible To Total Ratio (S/T)			Total Cool Cap.	Comp. Motor Input	Sensible To Total Ratio (S/T)			Total Cool Cap.	Comp. Motor Input	Sensible To Total Ratio (S/T)					
				Dry Bulb					Dry Bulb					Dry Bulb					
L/s	kW	kW	24°C	27°C	29°C	kW	kW	24°C	27°C	29°C	kW	kW	24°C	27°C	29°C				
17.2°C	1510	24.7	9.06	0.84	1.00	1.00	24.1	9.42	0.85	1.00	1.00	23.8	9.41	0.87	1.00	1.00			
	1890	26.4	9.15	0.92	1.00	1.00	25.7	9.53	0.93	1.00	1.00	25.4	9.50	0.94	1.00	1.00			
	2265	27.5	9.20	0.98	1.00	1.00	27.0	9.59	0.99	1.00	1.00	26.4	9.57	1.00	1.00	1.00			
19.4°C	1510	26.2	9.12	0.65	0.82	0.98	25.4	9.50	0.65	0.83	0.99	25.0	9.47	0.65	0.84	1.00			
	1890	27.3	9.17	0.69	0.89	1.00	26.4	9.56	0.70	0.91	1.00	26.0	9.52	0.71	0.92	1.00			
	2265	28.0	9.23	0.74	0.96	1.00	27.2	9.60	0.75	0.97	1.00	26.6	9.57	0.75	0.99	1.00			
21.7°C	1510	27.9	9.23	0.47	0.63	0.79	27.1	9.59	0.47	0.64	0.80	26.6	9.57	0.47	0.64	0.81			
	1890	29.0	9.29	0.49	0.68	0.86	28.1	9.64	0.49	0.69	0.88	27.6	9.62	0.50	0.70	0.89			
	2265	29.7	9.33	0.51	0.73	0.94	28.9	9.70	0.51	0.74	0.95	28.3	9.67	0.52	0.75	0.96			

RATINGS

ONE OUTDOOR UNIT + ONE INDOOR UNIT

NOTE - For Temperatures and Capacities not shown in tables, see bulletin - Cooling Unit Rating Table Correction Factor Data in Miscellaneous Engineering Data section.

ELS120S4D + ELA120S4D (1ST STAGE)

Entering Wet Bulb Temperature	Total Air Volume	Outdoor Air Temperature Entering Outdoor Coil																			
		18.3 °C					23.9 °C					29.4 °C					35 °C				
		Total Cool Cap.	Comp. Motor Input	Sensible To Total Ratio (S/T)			Total Cool Cap.	Comp. Motor Input	Sensible To Total Ratio (S/T)			Total Cool Cap.	Comp. Motor Input	Sensible To Total Ratio (S/T)			Total Cool Cap.	Comp. Motor Input	Sensible To Total Ratio (S/T)		
				Dry Bulb					Dry Bulb					Dry Bulb					Dry Bulb		
L/s	kW	kW	24°C	27°C	29°C	kW	kW	24°C	27°C	29°C	kW	kW	24°C	27°C	29°C	kW	kW	24°C	27°C	29°C	
17.2°C	1055	13.9	2.38	0.64	0.77	0.92	13.3	2.73	0.65	0.79	0.95	12.6	3.07	0.66	0.82	0.98	11.8	3.43	0.68	0.85	1
	1320	14.8	2.4	0.68	0.84	1	14.1	2.74	0.69	0.87	1	13.3	3.08	0.71	0.91	1	12.5	3.44	0.74	0.94	1
	1585	15.5	2.41	0.72	0.92	1	14.7	2.75	0.74	0.95	1	13.9	3.09	0.77	0.98	1	13.2	3.46	0.81	1	1
19.4°C	1055	15	2.4	0.51	0.61	0.72	14.3	2.74	0.52	0.63	0.74	13.5	3.08	0.52	0.64	0.77	12.8	3.45	0.53	0.65	0.8
	1320	15.9	2.42	0.53	0.65	0.79	15.2	2.76	0.54	0.67	0.82	14.4	3.1	0.55	0.68	0.85	13.5	3.46	0.56	0.7	0.89
	1585	16.6	2.44	0.55	0.69	0.87	15.8	2.77	0.56	0.71	0.9	14.9	3.11	0.58	0.73	0.94	14.1	3.48	0.59	0.77	0.98
21.7°C	1055	16	2.42	0.4	0.49	0.59	15.3	2.76	0.4	0.5	0.6	14.5	3.1	0.4	0.51	0.61	13.7	3.47	0.4	0.52	0.63
	1320	17	2.44	0.4	0.51	0.63	16.2	2.78	0.41	0.52	0.64	15.4	3.12	0.41	0.53	0.65	14.5	3.49	0.41	0.54	0.67
	1585	17.7	2.46	0.41	0.54	0.66	16.9	2.79	0.42	0.55	0.68	16	3.13	0.42	0.56	0.7	15.1	3.5	0.43	0.58	0.73

ELS120S4D + ELA120S4D (2ND STAGE)

Entering Wet Bulb Temperature	Total Air Volume	Outdoor Air Temperature Entering Outdoor Coil																			
		26.7 °C					35 °C					43.3 °C					46 °C				
		Total Cool Cap.	Comp. Motor Input	Sensible To Total Ratio (S/T)			Total Cool Cap.	Comp. Motor Input	Sensible To Total Ratio (S/T)			Total Cool Cap.	Comp. Motor Input	Sensible To Total Ratio (S/T)			Total Cool Cap.	Comp. Motor Input	Sensible To Total Ratio (S/T)		
				Dry Bulb					Dry Bulb					Dry Bulb					Dry Bulb		
L/s	kW	kW	24°C	27°C	29°C	kW	kW	24°C	27°C	29°C	kW	kW	24°C	27°C	29°C	kW	kW	24°C	27°C	29°C	
17.2°C	1510	29.6	5.76	0.78	0.94	1.00	27.4	6.83	0.81	0.97	1.00	25.2	8.16	0.85	1.00	1.00	25.2	8.69	0.86	1.00	1.00
	1890	31.1	5.79	0.84	1.00	1.00	29.2	6.87	0.88	1.00	1.00	27.1	8.22	0.92	1.00	1.00	27.1	8.74	0.94	1.00	1.00
	2265	32.8	5.82	0.90	1.00	1.00	30.7	6.90	0.94	1.00	1.00	28.5	8.27	0.98	1.00	1.00	28.5	8.79	1.00	1.00	1.00
19.4°C	1510	31.7	5.80	0.60	0.75	0.90	29.4	6.88	0.62	0.78	0.94	27.0	8.21	0.64	0.82	0.98	26.8	8.74	0.65	0.83	0.99
	1890	33.1	5.82	0.65	0.82	0.98	30.7	6.90	0.66	0.85	1.00	28.1	8.24	0.69	0.89	1.00	28.0	8.77	0.70	0.91	1.00
	2265	34.1	5.84	0.68	0.88	1.00	31.5	6.92	0.71	0.92	1.00	28.9	8.26	0.74	0.96	1.00	28.8	8.80	0.75	0.98	1.00
21.7°C	1510	33.7	5.83	0.45	0.59	0.73	31.5	6.92	0.46	0.61	0.75	29.0	8.27	0.46	0.63	0.79	28.9	8.81	0.47	0.64	0.80
	1890	35.2	5.86	0.46	0.63	0.79	32.8	6.95	0.47	0.65	0.82	30.2	8.31	0.49	0.68	0.86	30.1	8.85	0.49	0.69	0.88
	2265	36.3	5.88	0.48	0.67	0.85	33.8	6.97	0.49	0.70	0.89	31.0	8.34	0.51	0.73	0.93	30.9	8.88	0.51	0.74	0.95

Entering Wet Bulb Temperature	Total Air Volume	Outdoor Air Temperature Entering Outdoor Coil																	
		48 °C					50 °C					51.7 °C							
		Total Cool Cap.	Comp. Motor Input	Sensible To Total Ratio (S/T)			Total Cool Cap.	Comp. Motor Input	Sensible To Total Ratio (S/T)			Total Cool Cap.	Comp. Motor Input	Sensible To Total Ratio (S/T)					
				Dry Bulb					Dry Bulb					Dry Bulb					
L/s	kW	kW	24°C	27°C	29°C	kW	kW	24°C	27°C	29°C	kW	kW	24°C	27°C	29°C				
17.2°C	1510	24.7	9.10	0.87	1.00	1.00	24.1	9.55	0.89	1.00	1.00	23.0	9.93	0.90	1.00	1.00			
	1890	26.5	9.16	0.95	1.00	1.00	25.9	9.62	0.97	1.00	1.00	24.7	9.99	0.98	1.00	1.00			
	2265	27.9	9.22	1.00	1.00	1.00	27.3	9.68	1.00	1.00	1.00	26.0	10.07	1.00	1.00	1.00			
19.4°C	1510	26.2	9.15	0.66	0.84	1.00	25.5	9.60	0.67	0.85	1.00	24.2	9.97	0.67	0.87	1.00			
	1890	27.3	9.19	0.71	0.92	1.00	26.6	9.64	0.72	0.94	1.00	25.3	10.03	0.73	0.95	1.00			
	2265	28.1	9.22	0.76	0.99	1.00	27.4	9.66	0.77	1.00	1.00	26.1	10.06	0.78	1.00	1.00			
21.7°C	1510	28.3	9.23	0.47	0.64	0.81	27.5	9.69	0.47	0.65	0.82	26.2	10.08	0.48	0.66	0.83			
	1890	29.4	9.28	0.50	0.70	0.89	28.6	9.72	0.50	0.70	0.90	27.2	10.12	0.50	0.71	0.92			
	2265	30.2	9.30	0.51	0.75	0.96	29.5	9.77	0.52	0.76	0.97	28.0	10.16	0.53	0.77	0.98			

RATINGS

ONE OUTDOOR UNIT + ONE INDOOR UNIT

NOTE - For Temperatures and Capacities not shown in tables, see bulletin - Cooling Unit Rating Table Correction Factor Data in Miscellaneous Engineering Data section.

ELS150S4D + ELA150S4D (1ST STAGE)

Entering Wet Bulb Temperature	Total Air Volume	Outdoor Air Temperature Entering Outdoor Coil																				
		18.3°C						23.9°C					29.4°C					35°C				
		Total Cool Cap.	Comp. Motor Input	Sensible To Total Ratio (S/T)			Total Cool Cap.	Comp. Motor Input	Sensible To Total Ratio (S/T)			Total Cool Cap.	Comp. Motor Input	Sensible To Total Ratio (S/T)			Total Cool Cap.	Comp. Motor Input	Sensible To Total Ratio (S/T)			
				Dry Bulb					Dry Bulb					Dry Bulb					Dry Bulb			
		L/s	kW	kW	24°C	27°C	29°C	kW	kW	24°C	27°C	29°C	kW	kW	24°C	27°C	29°C	kW	kW	24°C	27°C	29°C
17.2°C	1320	17.3	2.77	0.68	0.8	0.93	16.6	3.16	0.69	0.82	0.95	15.7	3.59	0.7	0.84	0.98	14.9	4.08	0.72	0.87	1	
	1650	18.3	2.79	0.71	0.87	1	17.5	3.18	0.73	0.89	1	16.6	3.61	0.75	0.92	1	15.6	4.1	0.77	0.95	1	
	1980	19.1	2.81	0.76	0.93	1	18.2	3.2	0.78	0.95	1	17.2	3.63	0.8	0.98	1	16.3	4.13	0.83	1	1	
19.4°C	1320	18.5	2.8	0.54	0.65	0.76	17.7	3.18	0.55	0.66	0.78	16.8	3.62	0.55	0.67	0.8	15.9	4.11	0.56	0.69	0.82	
	1650	19.5	2.82	0.56	0.69	0.82	18.6	3.21	0.57	0.7	0.85	17.7	3.65	0.58	0.72	0.87	16.7	4.14	0.59	0.74	0.91	
	1980	20.3	2.84	0.59	0.73	0.89	19.4	3.23	0.6	0.75	0.92	18.3	3.66	0.61	0.77	0.95	17.2	4.16	0.62	0.8	0.98	
21.7°C	1320	19.7	2.83	0.41	0.52	0.62	18.8	3.22	0.42	0.53	0.64	17.9	3.66	0.42	0.54	0.65	16.9	4.15	0.43	0.55	0.66	
	1650	20.8	2.86	0.43	0.55	0.67	19.8	3.25	0.43	0.55	0.68	18.8	3.69	0.44	0.57	0.7	17.8	4.18	0.44	0.58	0.72	
	1980	21.5	2.88	0.43	0.57	0.71	20.5	3.27	0.44	0.58	0.72	19.5	3.71	0.44	0.6	0.74	18.3	4.2	0.45	0.61	0.77	

ELS150S4D + ELA150S4D (2ND STAGE)

Entering Wet Bulb Temperature	Total Air Volume	Outdoor Air Temperature Entering Outdoor Coil																				
		26.7°C						35°C					43.3°C					46°C				
		Total Cool Cap.	Comp. Motor Input	Sensible To Total Ratio (S/T)			Total Cool Cap.	Comp. Motor Input	Sensible To Total Ratio (S/T)			Total Cool Cap.	Comp. Motor Input	Sensible To Total Ratio (S/T)			Total Cool Cap.	Comp. Motor Input	Sensible To Total Ratio (S/T)			
				Dry Bulb					Dry Bulb					Dry Bulb					Dry Bulb			
		L/s	kW	kW	24°C	27°C	29°C	kW	kW	24°C	27°C	29°C	kW	kW	24°C	27°C	29°C	kW	kW	24°C	27°C	29°C
17.2°C	1890	36.2	6.75	0.79	0.95	1.00	33.4	8.16	0.82	0.98	1.00	30.7	9.92	0.86	1.00	1.00	27.8	12.13	0.92	1.00	1.00	
	2360	37.8	6.80	0.86	1.00	1.00	35.4	8.23	0.89	1.00	1.00	32.6	9.99	0.94	1.00	1.00	29.4	12.19	0.99	1.00	1.00	
	2830	39.7	6.87	0.92	1.00	1.00	37.0	8.29	0.96	1.00	1.00	34.0	10.05	0.99	1.00	1.00	30.6	12.25	1.00	1.00	1.00	
19.4°C	1890	38.5	6.83	0.61	0.77	0.91	35.5	8.24	0.63	0.79	0.95	32.4	9.99	0.65	0.84	0.99	28.7	12.17	0.69	0.89	1.00	
	2360	39.9	6.88	0.66	0.83	0.99	36.9	8.28	0.67	0.87	1.00	33.5	10.03	0.71	0.92	1.00	29.6	12.19	0.75	0.98	1.00	
	2830	41.0	6.92	0.69	0.90	1.00	37.7	8.32	0.72	0.94	1.00	34.3	10.05	0.76	0.98	1.00	30.6	12.25	0.81	1.00	1.00	
21.7°C	1890	40.7	6.91	0.45	0.60	0.74	37.7	8.31	0.46	0.62	0.77	34.4	10.07	0.47	0.64	0.81	30.5	12.24	0.49	0.68	0.87	
	2360	42.2	6.97	0.47	0.64	0.81	39.0	8.37	0.48	0.67	0.85	35.5	10.11	0.49	0.70	0.89	31.5	12.28	0.51	0.74	0.96	
	2830	43.3	7.00	0.49	0.69	0.87	40.0	8.42	0.50	0.71	0.91	36.3	10.15	0.52	0.75	0.96	32.1	12.30	0.54	0.80	1.00	
Entering Wet Bulb Temperature	Total Air Volume	Outdoor Air Temperature Entering Outdoor Coil																				
		48°C						50°C					51.7°C									
		Total Cool Cap.	Comp. Motor Input	Sensible To Total Ratio (S/T)			Total Cool Cap.	Comp. Motor Input	Sensible To Total Ratio (S/T)			Total Cool Cap.	Comp. Motor Input	Sensible To Total Ratio (S/T)								
				Dry Bulb					Dry Bulb					Dry Bulb								
		L/s	kW	kW	24°C	27°C	29°C	kW	kW	24°C	27°C	29°C	kW	kW	24°C	27°C	29°C					
17.2°C	1890	29.8	10.58	0.88	1.00	1.00	29.1	11.10	0.89	1.00	1.00	28.4	11.65	0.90	1.00	1.00						
	2360	31.6	10.64	0.95	1.00	1.00	30.9	11.16	0.97	1.00	1.00	30.0	11.70	0.98	1.00	1.00						
	2830	33.0	10.69	1.00	1.00	1.00	32.1	11.21	1.00	1.00	1.00	31.3	11.76	1.00	1.00	1.00						
19.4°C	1890	31.2	10.62	0.66	0.85	1.00	30.4	11.14	0.67	0.86	1.00	29.5	11.68	0.68	0.88	1.00						
	2360	32.3	10.66	0.72	0.93	1.00	31.4	11.16	0.73	0.95	1.00	30.5	11.71	0.74	0.96	1.00						
	2830	33.1	10.69	0.77	0.99	1.00	32.3	11.22	0.78	1.00	1.00	31.3	11.76	0.80	1.00	1.00						
21.7°C	1890	33.3	10.71	0.48	0.65	0.83	32.4	11.22	0.48	0.66	0.84	31.4	11.74	0.48	0.67	0.86						
	2360	34.3	10.74	0.50	0.71	0.91	33.4	11.25	0.50	0.72	0.93	32.4	11.81	0.51	0.73	0.94						
	2830	35.0	10.77	0.53	0.77	0.98	34.0	11.27	0.53	0.78	0.99	33.1	11.82	0.54	0.79	1.00						

RATINGS

ONE OUTDOOR UNIT + ONE INDOOR UNIT

NOTE - For Temperatures and Capacities not shown in tables, see bulletin - Cooling Unit Rating Table Correction Factor Data in Miscellaneous Engineering Data section.

ELS150S4D + ELA180S4D (1ST STAGE)

Entering Wet Bulb Temperature	Total Air Volume	Outdoor Air Temperature Entering Outdoor Coil																							
		18.3 °C						23.9 °C						29.4 °C						35 °C					
		Total Cool Cap.	Comp. Motor Input	Sensible To Total Ratio (S/T)			Total Cool Cap.	Comp. Motor Input	Sensible To Total Ratio (S/T)			Total Cool Cap.	Comp. Motor Input	Sensible To Total Ratio (S/T)			Total Cool Cap.	Comp. Motor Input	Sensible To Total Ratio (S/T)						
				Dry Bulb					Dry Bulb					Dry Bulb					Dry Bulb						
L/s	kW	kW	24°C	27°C	29°C	kW	kW	24°C	27°C	29°C	kW	kW	24°C	27°C	29°C	kW	kW	24°C	27°C	29°C					
17.2°C	1321	18.6	2.64	0.7	0.81	0.92	17.9	3.01	0.71	0.82	0.93	17.1	3.41	0.72	0.84	0.95	16.4	3.88	0.73	0.85	0.97				
	1652	19.6	2.67	0.74	0.86	0.98	18.8	3.03	0.75	0.88	0.99	18.1	3.44	0.76	0.9	1	17.2	3.9	0.77	0.92	1				
	1982	20.4	2.69	0.77	0.91	1	19.6	3.05	0.79	0.93	1	18.7	3.46	0.8	0.95	1	17.8	3.92	0.82	0.98	1				
19.4°C	1321	19.6	2.66	0.56	0.67	0.78	18.9	3.04	0.57	0.68	0.79	18.1	3.44	0.57	0.69	0.8	17.3	3.91	0.58	0.7	0.82				
	1652	20.7	2.69	0.58	0.71	0.83	19.9	3.06	0.59	0.72	0.85	19.1	3.47	0.6	0.74	0.86	18.2	3.94	0.61	0.75	0.89				
	1982	21.5	2.72	0.61	0.75	0.88	20.7	3.09	0.62	0.76	0.9	19.8	3.5	0.62	0.78	0.92	18.8	3.96	0.64	0.8	0.95				
21.7°C	1321	20.6	2.69	0.43	0.54	0.65	19.9	3.06	0.43	0.55	0.66	19	3.47	0.43	0.56	0.67	18.2	3.93	0.45	0.57	0.68				
	1652	21.8	2.73	0.45	0.57	0.69	21	3.1	0.43	0.57	0.7	20.1	3.51	0.44	0.58	0.71	19.2	3.97	0.46	0.59	0.73				
	1982	22.7	2.75	0.46	0.59	0.72	21.7	3.12	0.45	0.6	0.74	20.8	3.54	0.46	0.61	0.76	19.8	4	0.47	0.62	0.77				

ELS150S4D + ELA180S4D (2ND STAGE)

Entering Wet Bulb Temperature	Total Air Volume	Outdoor Air Temperature Entering Outdoor Coil																							
		26.7 °C						35 °C						43.3 °C						46 °C					
		Total Cool Cap.	Comp. Motor Input	Sensible To Total Ratio (S/T)			Total Cool Cap.	Comp. Motor Input	Sensible To Total Ratio (S/T)			Total Cool Cap.	Comp. Motor Input	Sensible To Total Ratio (S/T)			Total Cool Cap.	Comp. Motor Input	Sensible To Total Ratio (S/T)						
				Dry Bulb					Dry Bulb					Dry Bulb					Dry Bulb						
L/s	kW	kW	24°C	27°C	29°C	kW	kW	24°C	27°C	29°C	kW	kW	24°C	27°C	29°C	kW	kW	24°C	27°C	29°C					
17.2°C	1890	37.3	6.5	0.78	0.93	1	34.7	7.86	0.81	0.96	1	31.9	9.55	0.84	0.99	1	30.9	10.18	0.85	1.00	1.00				
	2360	38.9	6.56	0.84	0.99	1	36.3	7.92	0.87	1	1	33.6	9.61	0.91	1	1	32.7	10.23	0.92	1.00	1.00				
	2830	40.5	6.61	0.89	1	1	38	7.98	0.93	1	1	35.1	9.67	0.97	1	1	34.1	10.28	0.98	1.00	1.00				
19.4°C	1890	39.4	6.58	0.61	0.76	0.9	36.7	7.93	0.63	0.78	0.93	33.7	9.61	0.65	0.82	0.97	32.6	10.22	0.65	0.82	0.98				
	2360	41	6.63	0.65	0.82	0.97	38.1	7.99	0.67	0.85	1	34.8	9.65	0.69	0.89	1	33.7	10.26	0.70	0.90	1.00				
	2830	42.1	6.67	0.68	0.88	1	39.1	8.02	0.71	0.91	1	35.7	9.7	0.74	0.95	1	34.6	10.30	0.74	0.96	1.00				
21.7°C	1890	41.6	6.65	0.44	0.6	0.74	38.7	8	0.45	0.61	0.76	35.5	9.68	0.46	0.64	0.8	34.5	10.29	0.46	0.64	0.80				
	2360	43.2	6.71	0.45	0.63	0.8	40.2	8.07	0.47	0.66	0.83	36.8	9.73	0.49	0.68	0.87	35.6	10.33	0.48	0.69	0.88				
	2830	44.4	6.76	0.48	0.68	0.86	41.1	8.1	0.49	0.7	0.89	37.5	9.76	0.5	0.73	0.93	36.3	10.37	0.51	0.74	0.95				

Entering Wet Bulb Temperature	Total Air Volume	Outdoor Air Temperature Entering Outdoor Coil																	
		48 °C						50 °C						51.7 °C					
		Total Cool Cap.	Comp. Motor Input	Sensible To Total Ratio (S/T)			Total Cool Cap.	Comp. Motor Input	Sensible To Total Ratio (S/T)			Total Cool Cap.	Comp. Motor Input	Sensible To Total Ratio (S/T)					
				Dry Bulb					Dry Bulb					Dry Bulb					
L/s	kW	kW	24°C	27°C	29°C	kW	kW	24°C	27°C	29°C	kW	kW	24°C	27°C	29°C				
17.2°C	1890	30.2	10.66	0.86	1.00	1.00	29.5	11.20	0.87	1.00	1.00	28.9	11.67	0.89	1	1			
	2360	32.0	10.73	0.93	1.00	1.00	31.2	11.26	0.94	1.00	1.00	30.5	11.71	0.96	1	1			
	2830	33.3	10.78	0.99	1.00	1.00	32.4	11.29	1.00	1.00	1.00	31.8	11.78	1	1	1			
19.4°C	1890	31.8	10.72	0.66	0.83	0.99	30.9	11.24	0.66	0.85	1.00	30.1	11.7	0.68	0.87	1			
	2360	32.8	10.76	0.70	0.91	1.00	31.9	11.26	0.71	0.92	1.00	31.1	11.74	0.73	0.94	1			
	2830	33.6	10.79	0.75	0.98	1.00	32.6	11.29	0.76	0.99	1.00	31.8	11.76	0.78	1	1			
21.7°C	1890	33.6	10.79	0.47	0.64	0.81	32.7	11.30	0.47	0.65	0.82	31.9	11.76	0.47	0.67	0.84			
	2360	34.7	10.82	0.49	0.70	0.89	33.7	11.35	0.49	0.71	0.90	32.9	11.8	0.5	0.72	0.92			
	2830	35.4	10.85	0.51	0.75	0.96	34.3	11.35	0.52	0.76	0.97	33.5	11.84	0.53	0.78	0.99			

RATINGS

ONE OUTDOOR UNIT + ONE INDOOR UNIT

NOTE - For Temperatures and Capacities not shown in tables, see bulletin - Cooling Unit Rating Table Correction Factor Data in Miscellaneous Engineering Data section.

ELS180S4D + ELA180S4D (1ST STAGE)

Entering Wet Bulb Temperature	Total Air Volume	Outdoor Air Temperature Entering Outdoor Coil																				
		18.3°C						23.9°C					29.4°C					35°C				
		Total Cool Cap.	Comp. Motor Input	Sensible To Total Ratio (S/T)			Total Cool Cap.	Comp. Motor Input	Sensible To Total Ratio (S/T)			Total Cool Cap.	Comp. Motor Input	Sensible To Total Ratio (S/T)			Total Cool Cap.	Comp. Motor Input	Sensible To Total Ratio (S/T)			
				Dry Bulb					Dry Bulb					Dry Bulb					Dry Bulb			
L/s	kW	kW	24°C	27°C	29°C	kW	kW	24°C	27°C	29°C	kW	kW	24°C	27°C	29°C	kW	kW	24°C	27°C	29°C		
17.2°C	1510	22.6	4.1	0.67	0.77	0.87	21.7	4.57	0.68	0.78	0.89	20.7	5.09	0.69	0.8	0.91	19.6	5.68	0.7	0.82	0.93	
	1890	24.1	4.16	0.7	0.82	0.93	23.1	4.62	0.71	0.83	0.95	22	5.13	0.72	0.85	0.97	20.8	5.71	0.74	0.87	0.99	
	2265	25.1	4.21	0.73	0.86	0.98	24.1	4.66	0.74	0.88	1	22.9	5.18	0.76	0.9	1	21.7	5.75	0.78	0.93	1	
19.4°C	1510	24	4.15	0.54	0.64	0.74	23	4.62	0.55	0.65	0.75	22	5.13	0.55	0.66	0.76	20.9	5.73	0.56	0.67	0.78	
	1890	25.5	4.22	0.56	0.67	0.78	24.5	4.68	0.57	0.68	0.8	23.3	5.2	0.57	0.7	0.81	22.1	5.77	0.58	0.71	0.84	
	2265	26.7	4.27	0.58	0.7	0.83	25.5	4.73	0.58	0.72	0.84	24.3	5.24	0.59	0.73	0.87	23	5.82	0.61	0.75	0.89	
21.7°C	1510	25.3	4.21	0.43	0.53	0.62	24.3	4.67	0.43	0.53	0.62	23.2	5.18	0.43	0.54	0.63	22.1	5.77	0.44	0.54	0.65	
	1890	26.8	4.28	0.44	0.54	0.65	25.9	4.75	0.44	0.55	0.66	24.6	5.25	0.44	0.56	0.67	23.4	5.84	0.44	0.57	0.68	
	2265	28	4.34	0.44	0.56	0.68	27	4.8	0.44	0.57	0.69	25.7	5.31	0.45	0.58	0.71	24.4	5.88	0.45	0.59	0.72	

ELS180S4D + ELA180S4D (2ND STAGE)

Entering Wet Bulb Temperature	Total Air Volume	Outdoor Air Temperature Entering Outdoor Coil																				
		26.7°C						35°C					43.3°C					46°C				
		Total Cool Cap.	Comp. Motor Input	Sensible To Total Ratio (S/T)			Total Cool Cap.	Comp. Motor Input	Sensible To Total Ratio (S/T)			Total Cool Cap.	Comp. Motor Input	Sensible To Total Ratio (S/T)			Total Cool Cap.	Comp. Motor Input	Sensible To Total Ratio (S/T)			
				Dry Bulb					Dry Bulb					Dry Bulb					Dry Bulb			
L/s	kW	kW	24°C	27°C	29°C	kW	kW	24°C	27°C	29°C	kW	kW	24°C	27°C	29°C	kW	kW	24°C	27°C	29°C		
17.2°C	2265	47.6	9.58	0.75	0.89	1.00	43.9	11.26	0.77	0.92	1.00	39.9	13.34	0.81	0.97	1.00	39.1	14.09	0.82	0.99	1.00	
	2830	49.8	9.68	0.80	0.96	1.00	45.8	11.33	0.83	0.99	1.00	42.0	13.43	0.87	1.00	1.00	41.4	14.16	0.89	1.00	1.00	
	3400	51.5	9.73	0.85	1.00	1.00	47.9	11.41	0.89	1.00	1.00	44.1	13.52	0.94	1.00	1.00	43.4	14.25	0.95	1.00	1.00	
19.4°C	2265	50.6	9.69	0.59	0.72	0.85	46.7	11.38	0.60	0.75	0.89	42.5	13.42	0.62	0.78	0.94	41.7	14.18	0.63	0.80	0.95	
	2830	52.8	9.79	0.62	0.77	0.92	48.7	11.44	0.64	0.81	0.96	44.2	13.52	0.66	0.85	1.00	43.4	14.24	0.67	0.87	1.00	
	3400	54.5	9.85	0.65	0.82	0.98	50.2	11.52	0.67	0.86	1.00	45.4	13.56	0.70	0.91	1.00	44.5	14.29	0.72	0.93	1.00	
21.7°C	2265	53.3	9.81	0.45	0.57	0.70	49.5	11.50	0.45	0.59	0.72	45.1	13.53	0.46	0.61	0.76	44.3	14.28	0.46	0.62	0.77	
	2830	55.8	9.90	0.46	0.61	0.75	51.7	11.57	0.46	0.63	0.78	47.0	13.62	0.48	0.65	0.82	46.2	14.34	0.48	0.66	0.84	
	3400	57.6	10.00	0.47	0.64	0.80	53.2	11.65	0.48	0.66	0.84	48.3	13.67	0.49	0.69	0.89	47.4	14.39	0.50	0.71	0.91	

Entering Wet Bulb Temperature	Total Air Volume	Outdoor Air Temperature Entering Outdoor Coil																	
		48°C						50°C					51.7°C						
		Total Cool Cap.	Comp. Motor Input	Sensible To Total Ratio (S/T)			Total Cool Cap.	Comp. Motor Input	Sensible To Total Ratio (S/T)			Total Cool Cap.	Comp. Motor Input	Sensible To Total Ratio (S/T)					
				Dry Bulb					Dry Bulb					Dry Bulb					
L/s	kW	kW	24°C	27°C	29°C	kW	kW	24°C	27°C	29°C	kW	kW	24°C	27°C	29°C				
17.2°C	2265	38.0	14.70	0.83	1.00	1.00	36.9	15.33	0.85	1.00	1.00	35.5	15.95	0.86	1.00	1.00			
	2830	40.4	14.79	0.90	1.00	1.00	39.4	15.44	0.92	1.00	1.00	37.9	16.01	0.93	1.00	1.00			
	3400	42.3	14.83	0.97	1.00	1.00	41.2	15.52	0.98	1.00	1.00	39.7	16.09	0.99	1.00	1.00			
19.4°C	2265	40.6	14.80	0.64	0.81	0.97	39.3	15.42	0.65	0.82	0.98	37.7	16.02	0.65	0.83	0.99			
	2830	42.2	14.83	0.68	0.88	1.00	40.9	15.46	0.69	0.89	1.00	39.2	16.06	0.70	0.91	1.00			
	3400	43.3	14.89	0.73	0.94	1.00	42.0	15.51	0.74	0.96	1.00	40.1	16.10	0.75	0.97	1.00			
21.7°C	2265	43.2	14.90	0.47	0.63	0.78	41.9	15.52	0.47	0.63	0.79	40.2	16.12	0.47	0.64	0.80			
	2830	44.8	14.95	0.48	0.67	0.85	43.5	15.60	0.49	0.68	0.87	41.8	16.19	0.49	0.69	0.88			
	3400	46.1	14.98	0.50	0.72	0.92	44.6	15.61	0.51	0.73	0.94	42.8	16.20	0.51	0.74	0.95			

RATINGS

ONE OUTDOOR UNIT + ONE INDOOR UNIT

NOTE - For Temperatures and Capacities not shown in tables, see bulletin - Cooling Unit Rating Table Correction Factor Data in Miscellaneous Engineering Data section.

ELS180S4D + ELA240S4D (1ST STAGE)

Entering Wet Bulb Temperature	Total Air Volume	Outdoor Air Temperature Entering Outdoor Coil																							
		18.3 °C						23.9 °C						29.4 °C						35 °C					
		Total Cool Cap.	Comp. Motor Input	Sensible To Total Ratio (S/T)			Total Cool Cap.	Comp. Motor Input	Sensible To Total Ratio (S/T)			Total Cool Cap.	Comp. Motor Input	Sensible To Total Ratio (S/T)			Total Cool Cap.	Comp. Motor Input	Sensible To Total Ratio (S/T)						
				Dry Bulb					Dry Bulb					Dry Bulb					Dry Bulb						
L/s	kW	kW	24°C	27°C	29°C	kW	kW	24°C	27°C	29°C	kW	kW	24°C	27°C	29°C	kW	kW	24°C	27°C	29°C					
17.2°C	1510	23.8	3.79	0.65	0.76	0.86	23.1	4.22	0.66	0.77	0.88	22.2	4.69	0.67	0.78	0.89	21.2	5.23	0.67	0.79	0.91				
	1888	25.2	3.84	0.68	0.8	0.93	24.4	4.27	0.69	0.82	0.94	23.5	4.74	0.7	0.83	0.97	22.4	5.28	0.71	0.85	0.98				
	2265	26.3	3.9	0.72	0.86	0.99	25.4	4.31	0.72	0.87	1	24.4	4.78	0.74	0.89	1	23.3	5.31	0.76	0.91	1				
19.4°C	1510	25.3	3.85	0.53	0.63	0.72	24.4	4.27	0.54	0.64	0.73	23.6	4.75	0.54	0.64	0.75	22.6	5.28	0.54	0.65	0.76				
	1888	26.7	3.91	0.55	0.66	0.77	25.8	4.33	0.55	0.66	0.78	24.9	4.8	0.56	0.68	0.79	23.8	5.33	0.56	0.69	0.81				
	2265	27.9	3.97	0.57	0.7	0.82	26.9	4.38	0.57	0.7	0.83	25.9	4.84	0.58	0.71	0.85	24.8	5.37	0.58	0.73	0.87				
21.7°C	1510	26.6	3.91	0.42	0.51	0.6	25.9	4.33	0.42	0.52	0.61	24.9	4.8	0.42	0.52	0.62	23.9	5.34	0.42	0.53	0.62				
	1888	28.2	3.98	0.42	0.53	0.63	27.3	4.4	0.42	0.54	0.64	26.3	4.86	0.43	0.54	0.65	25.2	5.38	0.43	0.55	0.67				
	2265	29.4	4.03	0.42	0.55	0.67	28.4	4.45	0.42	0.55	0.67	27.3	4.91	0.42	0.56	0.68	26.2	5.44	0.42	0.57	0.71				

ELS180S4D + ELA240S4D (2ND STAGE)

Entering Wet Bulb Temperature	Total Air Volume	Outdoor Air Temperature Entering Outdoor Coil																							
		26.7 °C						35 °C						43.3 °C						46 °C					
		Total Cool Cap.	Comp. Motor Input	Sensible To Total Ratio (S/T)			Total Cool Cap.	Comp. Motor Input	Sensible To Total Ratio (S/T)			Total Cool Cap.	Comp. Motor Input	Sensible To Total Ratio (S/T)			Total Cool Cap.	Comp. Motor Input	Sensible To Total Ratio (S/T)						
				Dry Bulb					Dry Bulb					Dry Bulb					Dry Bulb						
L/s	kW	kW	24°C	27°C	29°C	kW	kW	24°C	27°C	29°C	kW	kW	24°C	27°C	29°C	kW	kW	24°C	27°C	29°C					
17.2°C	2265	50	8.88	0.74	0.88	1	46.8	10.39	0.76	0.91	1	43.2	12.29	0.79	0.95	1	42.0	13.00	0.81	0.97	1.00				
	2830	52.2	8.96	0.79	0.96	1	48.9	10.48	0.82	0.99	1	45.3	12.37	0.86	1	1	44.3	13.07	0.87	1.00	1.00				
	3400	54.1	9.04	0.85	1	1	51	10.56	0.88	1	1	47.6	12.47	0.92	1	1	46.4	13.17	0.94	1.00	1.00				
19.4°C	2265	53.1	9	0.58	0.71	0.85	49.8	10.52	0.6	0.74	0.88	46	12.38	0.61	0.76	0.92	44.7	13.09	0.62	0.78	0.94				
	2830	55.3	9.09	0.61	0.77	0.93	51.8	10.6	0.63	0.8	0.97	47.7	12.46	0.65	0.83	1	46.2	13.13	0.66	0.85	1.00				
	3400	56.9	9.17	0.65	0.83	1	53	10.65	0.66	0.86	1	49	12.53	0.7	0.9	1	47.4	13.19	0.70	0.92	1.00				
21.7°C	2265	56	9.12	0.44	0.57	0.69	52.6	10.64	0.45	0.58	0.71	48.7	12.51	0.44	0.6	0.74	47.4	13.20	0.45	0.61	0.76				
	2830	58.4	9.23	0.45	0.6	0.75	54.7	10.73	0.46	0.62	0.78	50.5	12.59	0.46	0.64	0.8	49.0	13.24	0.47	0.65	0.83				
	3400	60.1	9.31	0.45	0.64	0.81	56.1	10.79	0.46	0.65	0.84	51.8	12.65	0.48	0.69	0.88	50.4	13.33	0.48	0.71	0.90				

Entering Wet Bulb Temperature	Total Air Volume	Outdoor Air Temperature Entering Outdoor Coil																	
		48 °C						50 °C						51.7 °C					
		Total Cool Cap.	Comp. Motor Input	Sensible To Total Ratio (S/T)			Total Cool Cap.	Comp. Motor Input	Sensible To Total Ratio (S/T)			Total Cool Cap.	Comp. Motor Input	Sensible To Total Ratio (S/T)					
				Dry Bulb					Dry Bulb					Dry Bulb					
L/s	kW	kW	24°C	27°C	29°C	kW	kW	24°C	27°C	29°C	kW	kW	24°C	27°C	29°C				
17.2°C	2265	41.0	13.56	0.82	0.98	1.00	40.1	14.14	0.83	0.99	1.00	39.2	14.68	0.83	1	1			
	2830	43.4	13.63	0.88	1.00	1.00	42.5	14.23	0.89	1.00	1.00	41.7	14.77	0.9	1	1			
	3400	45.4	13.73	0.95	1.00	1.00	44.3	14.26	0.97	1.00	1.00	43.6	14.83	0.98	1	1			
19.4°C	2265	43.7	13.64	0.62	0.79	0.95	42.6	14.22	0.63	0.80	0.96	41.7	14.76	0.63	0.81	0.97			
	2830	45.2	13.68	0.67	0.86	1.00	44.1	14.28	0.68	0.87	1.00	43.1	14.8	0.68	0.88	1			
	3400	46.3	13.72	0.71	0.93	1.00	45.1	14.30	0.72	0.94	1.00	44.2	14.84	0.73	0.96	1			
21.7°C	2265	46.3	13.75	0.45	0.61	0.77	45.2	14.32	0.46	0.62	0.78	44.2	14.83	0.45	0.63	0.78			
	2830	47.9	13.80	0.47	0.66	0.84	46.8	14.39	0.47	0.67	0.85	45.8	14.92	0.47	0.67	0.85			
	3400	49.1	13.85	0.49	0.71	0.91	47.8	14.43	0.49	0.71	0.92	46.8	14.94	0.49	0.72	0.93			

RATINGS

ONE OUTDOOR UNIT + ONE INDOOR UNIT

NOTE - For Temperatures and Capacities not shown in tables, see bulletin - Cooling Unit Rating Table Correction Factor Data in Miscellaneous Engineering Data section.

ELS240S4D + ELA240S4D (1ST STAGE)

Entering Wet Bulb Temperature	Total Air Volume	Outdoor Air Temperature Entering Outdoor Coil																			
		18.3°C					23.9°C					29.4°C					35°C				
		Total Cool Cap.	Comp. Motor Input	Sensible To Total Ratio (S/T)			Total Cool Cap.	Comp. Motor Input	Sensible To Total Ratio (S/T)			Total Cool Cap.	Comp. Motor Input	Sensible To Total Ratio (S/T)			Total Cool Cap.	Comp. Motor Input	Sensible To Total Ratio (S/T)		
				Dry Bulb					Dry Bulb					Dry Bulb					Dry Bulb		
		L/s	kW	kW	24°C	27°C	29°C	kW	kW	24°C	27°C	29°C	kW	kW	24°C	27°C	29°C	kW	kW	24°C	27°C
17.2°C	2125	29.5	5.15	0.69	0.81	0.92	28.4	5.72	0.7	0.82	0.94	27.3	6.4	0.71	0.84	0.96	26.1	7.16	0.72	0.86	0.98
	2595	30.9	5.19	0.72	0.85	0.98	29.9	5.77	0.74	0.87	1	28.7	6.44	0.75	0.89	1	27.3	7.21	0.77	0.92	1
	3070	32.2	5.24	0.76	0.91	1	31	5.81	0.78	0.92	1	29.7	6.46	0.78	0.94	1	28.3	7.21	0.81	0.97	1
19.4°C	2125	31.5	5.22	0.55	0.67	0.77	30.3	5.78	0.56	0.67	0.78	29.1	6.43	0.56	0.68	0.8	27.9	7.22	0.57	0.7	0.82
	2595	33	5.26	0.57	0.7	0.82	31.9	5.84	0.57	0.72	0.84	30.6	6.5	0.59	0.72	0.86	29.3	7.27	0.6	0.74	0.88
	3070	34.2	5.31	0.6	0.74	0.87	33	5.87	0.6	0.75	0.89	31.6	6.53	0.6	0.75	0.91	30.2	7.31	0.61	0.78	0.93
21.7°C	2125	33.6	5.28	0.42	0.53	0.64	32.5	5.86	0.42	0.54	0.64	31.2	6.51	0.43	0.54	0.66	29.8	7.26	0.43	0.55	0.67
	2595	35	5.33	0.43	0.54	0.67	33.9	5.91	0.43	0.58	0.69	32.6	6.58	0.43	0.57	0.7	31.1	7.32	0.44	0.57	0.71
	3070	36.2	5.38	0.45	0.58	0.71	34.9	5.95	0.44	0.59	0.72	33.5	6.6	0.45	0.58	0.73	32	7.35	0.44	0.6	0.75

ELS240S4D + ELA240S4D (2ND STAGE)

Entering Wet Bulb Temperature	Total Air Volume	Outdoor Air Temperature Entering Outdoor Coil																			
		26.7°C					35°C					43.3°C					46°C				
		Total Cool Cap.	Comp. Motor Input	Sensible To Total Ratio (S/T)			Total Cool Cap.	Comp. Motor Input	Sensible To Total Ratio (S/T)			Total Cool Cap.	Comp. Motor Input	Sensible To Total Ratio (S/T)			Total Cool Cap.	Comp. Motor Input	Sensible To Total Ratio (S/T)		
				Dry Bulb					Dry Bulb					Dry Bulb					Dry Bulb		
		L/s	kW	kW	24°C	27°C	29°C	kW	kW	24°C	27°C	29°C	kW	kW	24°C	27°C	29°C	kW	kW	24°C	27°C
17.2°C	3020	60.3	11.2	0.77	0.93	1	56	13.05	0.8	0.97	1	51.5	15.33	0.84	1	1	50.0	16.14	0.85	1	1
	3775	62.9	11.33	0.84	1	1	58.9	13.2	0.87	1	1	54.7	15.5	0.91	1	1	53.3	16.32	0.93	1	1
	4530	65.8	11.48	0.89	1	1	61.7	13.34	0.94	1	1	57.1	15.64	0.98	1	1	55.7	16.45	0.99	1	1
19.4°C	3020	64.1	11.39	0.61	0.75	0.9	59.6	13.24	0.62	0.78	0.93	54.8	15.51	0.64	0.81	0.98	53.2	16.32	0.65	0.83	0.99
	3775	66.7	11.53	0.63	0.81	0.97	62	13.36	0.66	0.85	1	56.7	15.61	0.69	0.89	1	54.9	16.41	0.70	0.91	1
	4530	68.5	11.62	0.67	0.87	1	63.5	13.45	0.71	0.91	1	58.1	15.68	0.73	0.96	1	56.2	16.48	0.75	0.98	1
21.7°C	3020	68.1	11.6	0.44	0.59	0.72	63.2	13.43	0.45	0.61	0.75	58.2	15.69	0.47	0.63	0.79	56.5	16.51	0.47	0.64	0.80
	3775	70.7	11.73	0.45	0.63	0.79	65.6	13.56	0.47	0.65	0.82	60.2	15.8	0.48	0.68	0.86	58.4	16.61	0.48	0.69	0.88
	4530	72.5	11.82	0.46	0.67	0.85	67.2	13.65	0.48	0.69	0.89	61.6	15.88	0.5	0.73	0.94	59.8	16.68	0.49	0.74	0.96

Entering Wet Bulb Temperature	Total Air Volume	Outdoor Air Temperature Entering Outdoor Coil																	
		48°C					50°C					51.7°C							
		Total Cool Cap.	Comp. Motor Input	Sensible To Total Ratio (S/T)			Total Cool Cap.	Comp. Motor Input	Sensible To Total Ratio (S/T)			Total Cool Cap.	Comp. Motor Input	Sensible To Total Ratio (S/T)					
				Dry Bulb					Dry Bulb					Dry Bulb					
		L/s	kW	kW	24°C	27°C	29°C	kW	kW	24°C	27°C	29°C	kW	kW	24°C	27°C	29°C		
17.2°C	3020	49	16.8	0.87	1	1	47.9	17.5	0.88	1	1	47	18.1	0.89	1	1			
	3775	52.1	16.98	0.95	1	1	50.8	17.65	0.96	1	1	49.8	18.27	0.97	1	1			
	4530	54.5	17.11	1	1	1	53.1	17.78	1	1	1	51.9	18.39	1	1	1			
19.4°C	3020	51.9	16.95	0.66	0.84	0.99	50.5	17.64	0.66	0.85	1	49.2	18.22	0.67	0.86	1			
	3775	53.5	17.06	0.71	0.92	1	52	17.72	0.71	0.93	1	50.8	18.33	0.73	0.95	1			
	4530	54.8	17.13	0.76	0.99	1	53.3	17.79	0.77	0.99	1	52.2	18.41	0.78	1	1			
21.7°C	3020	55.2	17.14	0.47	0.64	0.81	53.7	17.81	0.47	0.65	0.82	52.4	18.41	0.47	0.66	0.84			
	3775	56.9	17.25	0.49	0.7	0.89	55.4	17.92	0.49	0.7	0.91	54.1	18.52	0.49	0.72	0.92			
	4530	58.3	17.33	0.5	0.75	0.97	56.7	17.99	0.51	0.76	0.96	55.3	18.59	0.52	0.77	0.99			

RATINGS

ONE OUTDOOR UNIT + TWO INDOOR UNITS

NOTE - For Temperatures and Capacities not shown in tables, see bulletin - Cooling Unit Rating Table Correction Factor Data in Miscellaneous Engineering Data section.

ELS090S4S + (2) CX35-60D (1ST STAGE)

Entering Wet Bulb Temperature	Total Air Volume	Outdoor Air Temperature Entering Outdoor Coil																			
		18.3 °C					23.9 °C					29.4 °C					35 °C				
		Total Cool Cap.	Comp. Motor Input	Sensible To Total Ratio (S/T)			Total Cool Cap.	Comp. Motor Input	Sensible To Total Ratio (S/T)			Total Cool Cap.	Comp. Motor Input	Sensible To Total Ratio (S/T)			Total Cool Cap.	Comp. Motor Input	Sensible To Total Ratio (S/T)		
				Dry Bulb					Dry Bulb					Dry Bulb					Dry Bulb		
L/s	kW	kW	24°C	27°C	29°C	kW	kW	24°C	27°C	29°C	kW	kW	24°C	27°C	29°C	kW	kW	24°C	27°C	29°C	
17.2°C	755	16.2	2.27	0.66	0.82	1	15.4	2.66	0.68	0.86	1	14.7	3.09	0.7	0.91	1	13.8	3.57	0.72	0.98	1
	944	17.1	2.26	0.7	0.94	1	16.3	2.65	0.72	0.98	1	15.6	3.09	0.75	1	1	14.8	3.56	0.8	1	1
	1133	18	2.26	0.75	1	1	17.3	2.65	0.79	1	1	16.5	3.08	0.84	1	1	15.6	3.56	0.91	1	1
19.4°C	755	17.3	2.26	0.52	0.64	0.75	16.5	2.65	0.53	0.65	0.79	15.7	3.08	0.54	0.67	0.84	14.7	3.56	0.55	0.69	0.9
	944	18.3	2.26	0.55	0.68	0.86	17.4	2.65	0.56	0.7	0.91	16.5	3.08	0.57	0.72	0.97	15.5	3.56	0.59	0.75	1
	1133	19	2.25	0.57	0.72	0.97	18.1	2.64	0.59	0.74	1	17.2	3.08	0.6	0.78	1	16.1	3.56	0.62	0.85	1
21.7°C	755	18.3	2.25	0.4	0.51	0.61	17.6	2.65	0.4	0.52	0.63	16.7	3.08	0.4	0.52	0.64	15.8	3.56	0.4	0.53	0.67
	944	19.4	2.25	0.41	0.53	0.65	18.5	2.64	0.41	0.54	0.67	17.6	3.08	0.41	0.55	0.69	16.6	3.56	0.42	0.56	0.72
	1133	20.2	2.25	0.41	0.56	0.69	19.3	2.64	0.42	0.57	0.72	18.2	3.07	0.43	0.59	0.74	17.1	3.55	0.44	0.61	0.8

ELS090S4S + (2) CX35-60D (2ND STAGE)

Entering Wet Bulb Temperature	Total Air Volume	Outdoor Air Temperature Entering Outdoor Coil																			
		26.7 °C					35 °C					43.3 °C					46 °C				
		Total Cool Cap.	Comp. Motor Input	Sensible To Total Ratio (S/T)			Total Cool Cap.	Comp. Motor Input	Sensible To Total Ratio (S/T)			Total Cool Cap.	Comp. Motor Input	Sensible To Total Ratio (S/T)			Total Cool Cap.	Comp. Motor Input	Sensible To Total Ratio (S/T)		
				Dry Bulb					Dry Bulb					Dry Bulb					Dry Bulb		
L/s	kW	kW	24°C	27°C	29°C	kW	kW	24°C	27°C	29°C	kW	kW	24°C	27°C	29°C	kW	kW	24°C	27°C	29°C	
17.2°C	1135	24.9	4.77	0.74	0.88	1	23.2	5.54	0.76	0.91	1	21.2	6.43	0.8	0.96	1	20.5	6.74	0.82	0.98	1.00
	1415	26.2	4.86	0.79	0.95	1	24.3	5.62	0.82	0.99	1	22.4	6.53	0.86	1	1	21.8	6.84	0.88	1.00	1.00
	1700	27.2	4.93	0.83	1	1	25.4	5.71	0.87	1	1	23.6	6.63	0.92	1	1	23.0	6.94	0.94	1.00	1.00
19.4°C	1135	26.3	4.87	0.58	0.71	0.84	24.5	5.64	0.6	0.74	0.88	22.5	6.54	0.62	0.77	0.92	21.8	6.84	0.63	0.79	0.94
	1415	27.7	4.96	0.62	0.76	0.91	25.7	5.73	0.63	0.79	0.95	23.6	6.62	0.66	0.83	1	22.8	6.92	0.67	0.85	1.00
	1700	28.8	5.03	0.64	0.81	0.97	26.6	5.8	0.66	0.84	1	24.3	6.69	0.69	0.89	1	23.5	6.99	0.71	0.92	1.00
21.7°C	1135	27.9	4.97	0.44	0.57	0.69	26	5.75	0.45	0.58	0.71	23.9	6.65	0.46	0.6	0.74	23.3	6.96	0.46	0.61	0.76
	1415	29.2	5.07	0.46	0.6	0.74	27.2	5.84	0.46	0.62	0.77	25	6.73	0.47	0.64	0.8	24.2	7.05	0.48	0.65	0.82
	1700	30.2	5.14	0.47	0.63	0.78	28.1	5.91	0.48	0.65	0.82	25.8	6.8	0.49	0.68	0.87	25.0	7.11	0.50	0.69	0.89

Entering Wet Bulb Temperature	Total Air Volume	Outdoor Air Temperature Entering Outdoor Coil																	
		48 °C					50 °C					51.7 °C							
		Total Cool Cap.	Comp. Motor Input	Sensible To Total Ratio (S/T)			Total Cool Cap.	Comp. Motor Input	Sensible To Total Ratio (S/T)			Total Cool Cap.	Comp. Motor Input	Sensible To Total Ratio (S/T)					
				Dry Bulb					Dry Bulb					Dry Bulb					
L/s	kW	kW	24°C	27°C	29°C	kW	kW	24°C	27°C	29°C	kW	kW	24°C	27°C	29°C				
17.2°C	1135	20.0	6.98	0.83	0.99	1.00	19.5	7.23	0.84	1.00	1.00	19	7.46	0.85	1	1			
	1415	21.4	7.10	0.90	1.00	1.00	20.9	7.36	0.91	1.00	1.00	20.4	7.59	0.92	1	1			
	1700	22.4	7.19	0.96	1.00	1.00	21.9	7.44	0.98	1.00	1.00	21.4	7.67	0.99	1	1			
19.4°C	1135	21.3	7.09	0.64	0.80	0.96	20.7	7.34	0.64	0.81	0.97	20.2	7.56	0.64	0.82	0.98			
	1415	22.2	7.17	0.67	0.87	1.00	21.6	7.43	0.68	0.88	1.00	21.1	7.65	0.69	0.89	1			
	1700	22.9	7.23	0.72	0.93	1.00	22.3	7.49	0.73	0.95	1.00	21.7	7.71	0.73	0.96	1			
21.7°C	1135	22.7	7.20	0.46	0.62	0.77	22.1	7.47	0.46	0.63	0.78	21.6	7.7	0.47	0.63	0.79			
	1415	23.6	7.29	0.48	0.66	0.84	22.9	7.54	0.48	0.67	0.85	22.4	7.78	0.49	0.68	0.86			
	1700	24.3	7.35	0.50	0.70	0.90	23.7	7.60	0.50	0.71	0.92	23.1	7.82	0.5	0.72	0.93			

RATINGS

ONE OUTDOOR UNIT + TWO INDOOR UNITS

NOTE - For Temperatures and Capacities not shown in tables, see bulletin - Cooling Unit Rating Table Correction Factor Data in Miscellaneous Engineering Data section.

ELS090S4D + (2) CX35-60C (1ST STAGE)

Entering Wet Bulb Temperature	Total Air Volume	Outdoor Air Temperature Entering Outdoor Coil																				
		18.3°C						23.9°C					29.4°C					35°C				
		Total Cool Cap.	Comp. Motor Input	Sensible To Total Ratio (S/T)			Total Cool Cap.	Comp. Motor Input	Sensible To Total Ratio (S/T)			Total Cool Cap.	Comp. Motor Input	Sensible To Total Ratio (S/T)			Total Cool Cap.	Comp. Motor Input	Sensible To Total Ratio (S/T)			
				Dry Bulb					Dry Bulb					Dry Bulb					Dry Bulb			
		L/s	kW	kW	24°C	27°C	29°C	kW	kW	24°C	27°C	29°C	kW	kW	24°C	27°C	29°C	kW	kW	24°C	27°C	29°C
17.2°C	755	16.9	2.26	1	0.99	0.98	16.1	2.66	1	0.98	0.98	15.2	3.09	1	0.99	0.98	14.4	3.56	1	1	0.98	
	944	18	2.26	1	1	0.98	17.2	2.65	0.99	1	0.98	16.4	3.08	0.99	1	0.99	15.6	3.56	0.99	1	0.99	
	1133	19	2.25	0.98	1	0.99	18.2	2.64	1	1	0.99	17.4	3.07	1	1	1	16.4	3.56	1	1	1	
19.4°C	755	18.1	2.26	0.96	1	1	17.2	2.65	0.97	1	0.99	16.3	3.08	0.98	1	0.98	15.3	3.56	0.99	1	1	
	944	19.1	2.25	0.98	1	0.99	18.1	2.64	0.99	1	1	17.1	3.08	1	0.99	1	16	3.56	1	0.98	1	
	1133	19.8	2.25	1	0.99	1	18.8	2.64	1	0.98	1	17.7	3.07	1	1	1	16.6	3.56	1	1	1	
21.7°C	755	19.2	2.25	0.89	0.96	0.99	18.4	2.64	0.9	0.97	1	17.5	3.08	0.91	0.97	1	16.4	3.56	0.93	0.98	1	
	944	20.1	2.24	0.93	0.98	1	19.3	2.63	0.94	0.99	1	18.3	3.07	0.95	1	0.99	17.2	3.55	0.96	1	0.98	
	1133	21	2.24	0.95	1	0.99	20	2.63	0.97	1	0.98	18.9	3.07	0.97	1	1	17.8	3.55	0.98	1	1	

ELS090S4D + (2) CX35-60C (2ND STAGE)

Entering Wet Bulb Temperature	Total Air Volume	Outdoor Air Temperature Entering Outdoor Coil																				
		26.7°C						35°C					43.3°C					46°C				
		Total Cool Cap.	Comp. Motor Input	Sensible To Total Ratio (S/T)			Total Cool Cap.	Comp. Motor Input	Sensible To Total Ratio (S/T)			Total Cool Cap.	Comp. Motor Input	Sensible To Total Ratio (S/T)			Total Cool Cap.	Comp. Motor Input	Sensible To Total Ratio (S/T)			
				Dry Bulb					Dry Bulb					Dry Bulb					Dry Bulb			
		L/s	kW	kW	24°C	27°C	29°C	kW	kW	24°C	27°C	29°C	kW	kW	24°C	27°C	29°C	kW	kW	24°C	27°C	29°C
17.2°C	1135	25.8	4.83	0.94	1	1	23.9	5.6	0.97	1	1	21.9	6.48	1	1	1	21.3	6.80	1.00	1.00	1.00	
	1415	27.1	4.92	1	1	1	25.4	5.7	1	1	1	23.4	6.61	1	1	1	22.8	6.93	1.00	1.00	1.00	
	1700	28.5	5.01	1	1	1	26.7	5.8	1	1	1	24.7	6.71	1	1	1	23.9	7.01	1.00	1.00	1.00	
19.4°C	1135	27.4	4.94	0.81	0.92	1	25.5	5.71	0.84	0.95	1	23.3	6.6	0.87	0.99	1	22.6	6.91	0.86	1.00	1.00	
	1415	28.7	5.03	0.87	0.99	1	26.5	5.79	0.9	1	1	24.2	6.68	0.94	1	1	23.4	6.98	0.95	1.00	1.00	
	1700	29.6	5.09	0.93	1	1	27.3	5.85	0.96	1	1	24.9	6.73	1	1	1	24.1	7.04	1.00	1.00	1.00	
21.7°C	1135	29	5.05	0.71	0.82	0.91	27	5.83	0.72	0.84	0.94	24.8	6.72	0.75	0.87	0.98	24.0	7.03	0.71	0.86	1.00	
	1415	30.2	5.13	0.76	0.87	0.98	28.1	5.91	0.78	0.91	1	25.8	6.8	0.81	0.95	1	25.0	7.11	0.78	0.95	1.00	
	1700	31.1	5.19	0.8	0.93	1	28.9	5.98	0.83	0.97	1	26.5	6.86	0.87	1	1	25.6	7.16	0.85	1.00	1.00	

Entering Wet Bulb Temperature	Total Air Volume	Outdoor Air Temperature Entering Outdoor Coil																	
		48°C						50°C					51.7°C						
		Total Cool Cap.	Comp. Motor Input	Sensible To Total Ratio (S/T)			Total Cool Cap.	Comp. Motor Input	Sensible To Total Ratio (S/T)			Total Cool Cap.	Comp. Motor Input	Sensible To Total Ratio (S/T)					
				Dry Bulb					Dry Bulb					Dry Bulb					
		L/s	kW	kW	24°C	27°C	29°C	kW	kW	24°C	27°C	29°C	kW	kW	24°C	27°C	29°C		
17.2°C	1135	20.8	7.04	1.00	1.00	1.00	20.3	7.31	1.00	1.00	1.00	19.9	7.54	1	1	1			
	1415	22.3	7.18	1.00	1.00	1.00	21.8	7.44	1.00	1.00	1.00	21.3	7.67	1	1	1			
	1700	23.4	7.27	1.00	1.00	1.00	22.8	7.53	1.00	1.00	1.00	22.3	7.76	1	1	1			
19.4°C	1135	21.9	7.14	0.87	1.00	1.00	21.4	7.40	0.88	1.00	1.00	20.7	7.62	0.92	1	1			
	1415	22.8	7.22	0.96	1.00	1.00	22.2	7.47	0.98	1.00	1.00	21.5	7.7	1	1	1			
	1700	23.4	7.27	1.00	1.00	1.00	22.8	7.54	1.00	1.00	1.00	22.3	7.76	1	1	1			
21.7°C	1135	23.4	7.28	0.72	0.87	1.00	22.8	7.52	0.73	0.88	1.00	22.2	7.74	0.78	0.92	1			
	1415	24.4	7.36	0.79	0.97	1.00	23.7	7.60	0.80	0.98	1.00	23.1	7.84	0.85	1	1			
	1700	25.0	7.41	0.86	1.00	1.00	24.4	7.66	0.88	1.00	1.00	23.7	7.89	0.91	1	1			

RATINGS

ONE OUTDOOR UNIT + TWO INDOOR UNITS

NOTE - For Temperatures and Capacities not shown in tables, see bulletin - Cooling Unit Rating Table Correction Factor Data in Miscellaneous Engineering Data section.

ELS120S4D + (2) CH33-62D (1ST STAGE)

Entering Wet Bulb Temperature	Total Air Volume	Outdoor Air Temperature Entering Outdoor Coil																			
		18.3 °C					23.9 °C					29.4 °C					35 °C				
		Total Cool Cap.	Comp. Motor Input	Sensible To Total Ratio (S/T)			Total Cool Cap.	Comp. Motor Input	Sensible To Total Ratio (S/T)			Total Cool Cap.	Comp. Motor Input	Sensible To Total Ratio (S/T)			Total Cool Cap.	Comp. Motor Input	Sensible To Total Ratio (S/T)		
				Dry Bulb					Dry Bulb					Dry Bulb					Dry Bulb		
L/s	kW	kW	24°C	27°C	29°C	kW	kW	24°C	27°C	29°C	kW	kW	24°C	27°C	29°C	kW	kW	24°C	27°C	29°C	
17.2°C	755	12.2	2.31	0.56	0.67	0.78	11.7	2.66	0.57	0.68	0.8	11.2	3	0.57	0.7	0.83	10.6	3.35	0.58	0.72	0.86
	945	13.2	2.33	0.58	0.71	0.84	12.7	2.68	0.59	0.73	0.87	12	3.01	0.6	0.75	0.9	11.4	3.37	0.62	0.78	0.94
	1135	14	2.35	0.61	0.75	0.9	13.4	2.69	0.62	0.77	0.93	12.7	3.03	0.64	0.8	0.97	12	3.38	0.66	0.83	1
19.4°C	755	13	2.33	0.46	0.54	0.62	12.5	2.67	0.46	0.54	0.64	12	3.01	0.47	0.55	0.65	11.4	3.37	0.47	0.56	0.67
	945	14	2.35	0.47	0.56	0.66	13.5	2.69	0.47	0.56	0.68	12.9	3.03	0.48	0.57	0.7	12.2	3.39	0.49	0.59	0.72
	1135	14.8	2.36	0.48	0.58	0.7	14.2	2.7	0.49	0.59	0.72	13.6	3.04	0.49	0.6	0.75	12.9	3.4	0.5	0.62	0.78
21.7°C	755	13.8	2.34	0.37	0.44	0.51	13.3	2.69	0.37	0.45	0.52	12.7	3.03	0.37	0.45	0.53	12.1	3.38	0.37	0.45	0.54
	945	14.9	2.37	0.37	0.45	0.53	14.3	2.71	0.37	0.46	0.54	13.7	3.04	0.37	0.46	0.55	13.1	3.4	0.38	0.47	0.56
	1135	15.8	2.38	0.37	0.47	0.55	15.1	2.72	0.38	0.47	0.56	14.4	3.06	0.38	0.48	0.57	13.7	3.42	0.38	0.49	0.59

ELS120S4D + (2) CH33-62D (2ND STAGE)

Entering Wet Bulb Temperature	Total Air Volume	Outdoor Air Temperature Entering Outdoor Coil																			
		26.7 °C					35 °C					43.3 °C					46 °C				
		Total Cool Cap.	Comp. Motor Input	Sensible To Total Ratio (S/T)			Total Cool Cap.	Comp. Motor Input	Sensible To Total Ratio (S/T)			Total Cool Cap.	Comp. Motor Input	Sensible To Total Ratio (S/T)			Total Cool Cap.	Comp. Motor Input	Sensible To Total Ratio (S/T)		
				Dry Bulb					Dry Bulb					Dry Bulb					Dry Bulb		
L/s	kW	kW	24°C	27°C	29°C	kW	kW	24°C	27°C	29°C	kW	kW	24°C	27°C	29°C	kW	kW	24°C	27°C	29°C	
17.2°C	1510	29.4	5.78	0.75	0.88	1.00	27.2	6.85	0.77	0.92	1.00	24.9	8.17	0.81	0.97	1.00	24.1	8.66	0.82	0.98	1.00
	1890	30.8	5.80	0.79	0.95	1.00	28.5	6.88	0.82	0.99	1.00	26.2	8.21	0.87	1.00	1.00	25.6	8.72	0.88	1.00	1.00
	2265	31.9	5.82	0.84	1.00	1.00	29.7	6.91	0.87	1.00	1.00	27.6	8.25	0.92	1.00	1.00	26.9	8.76	0.94	1.00	1.00
19.4°C	1510	31.1	5.80	0.59	0.72	0.85	28.9	6.89	0.61	0.75	0.88	26.6	8.22	0.62	0.78	0.93	25.8	8.73	0.63	0.79	0.94
	1890	32.7	5.83	0.62	0.77	0.91	30.3	6.91	0.64	0.80	0.95	27.8	8.27	0.66	0.84	0.99	27.0	8.78	0.67	0.85	1.00
	2265	33.8	5.85	0.64	0.81	0.97	31.4	6.94	0.67	0.85	1.00	28.7	8.29	0.69	0.89	1.00	27.8	8.80	0.70	0.91	1.00
21.7°C	1510	32.9	5.83	0.45	0.58	0.70	30.7	6.92	0.45	0.59	0.72	28.4	8.28	0.46	0.61	0.75	27.6	8.79	0.46	0.62	0.76
	1890	34.5	5.86	0.46	0.60	0.74	32.2	6.96	0.47	0.62	0.77	29.7	8.32	0.48	0.65	0.81	28.9	8.84	0.48	0.65	0.82
	2265	35.7	5.89	0.47	0.63	0.79	33.3	6.98	0.48	0.65	0.82	30.6	8.35	0.49	0.68	0.86	29.7	8.87	0.50	0.69	0.88

Entering Wet Bulb Temperature	Total Air Volume	Outdoor Air Temperature Entering Outdoor Coil																	
		48 °C					50 °C					51.7 °C							
		Total Cool Cap.	Comp. Motor Input	Sensible To Total Ratio (S/T)			Total Cool Cap.	Comp. Motor Input	Sensible To Total Ratio (S/T)			Total Cool Cap.	Comp. Motor Input	Sensible To Total Ratio (S/T)					
				Dry Bulb					Dry Bulb					Dry Bulb					
L/s	kW	kW	24°C	27°C	29°C	kW	kW	24°C	27°C	29°C	kW	kW	24°C	27°C	29°C				
17.2°C	1510	23.5	9.08	0.83	0.99	1.00	22.9	9.52	0.84	1.00	1.00	22.4	9.93	0.85	1.00	1.00			
	1890	25.1	9.14	0.89	1.00	1.00	24.5	9.58	0.91	1.00	1.00	24.1	10.01	0.92	1.00	1.00			
	2265	26.4	9.19	0.95	1.00	1.00	25.8	9.63	0.97	1.00	1.00	25.4	10.06	0.98	1.00	1.00			
19.4°C	1510	25.1	9.14	0.64	0.80	0.96	24.5	9.59	0.64	0.81	0.97	24.0	10.00	0.65	0.82	0.98			
	1890	26.3	9.18	0.68	0.86	1.00	25.7	9.63	0.68	0.88	1.00	25.1	10.04	0.69	0.89	1.00			
	2265	27.2	9.23	0.71	0.92	1.00	26.5	9.67	0.72	0.94	1.00	25.9	10.08	0.73	0.95	1.00			
21.7°C	1510	27.0	9.21	0.47	0.62	0.77	26.3	9.67	0.47	0.63	0.78	25.8	10.09	0.47	0.63	0.79			
	1890	28.2	9.26	0.48	0.66	0.83	27.5	9.72	0.49	0.67	0.84	27.0	10.15	0.49	0.68	0.85			
	2265	29.0	9.29	0.50	0.70	0.89	28.3	9.75	0.50	0.71	0.91	27.7	10.17	0.51	0.72	0.92			

RATINGS

ONE OUTDOOR UNIT + TWO INDOOR UNITS

NOTE - For Temperatures and Capacities not shown in tables, see bulletin - Cooling Unit Rating Table Correction Factor Data in Miscellaneous Engineering Data section.

ELS120S4D + (2) CH23-68 (1ST STAGE)

Entering Wet Bulb Temperature	Total Air Volume	Outdoor Air Temperature Entering Outdoor Coil																			
		18.3°C					23.9°C					29.4°C					35°C				
		Total Cool Cap.	Comp. Motor Input	Sensible To Total Ratio (S/T)			Total Cool Cap.	Comp. Motor Input	Sensible To Total Ratio (S/T)			Total Cool Cap.	Comp. Motor Input	Sensible To Total Ratio (S/T)			Total Cool Cap.	Comp. Motor Input	Sensible To Total Ratio (S/T)		
				Dry Bulb					Dry Bulb					Dry Bulb					Dry Bulb		
L/s	kW	kW	24°C	27°C	29°C	kW	kW	24°C	27°C	29°C	kW	kW	24°C	27°C	29°C	kW	kW	24°C	27°C	29°C	
17.2°C	755	12.4	2.32	0.56	0.67	0.79	11.9	2.66	0.57	0.68	0.81	11.3	3	0.58	0.7	0.84	10.7	3.35	0.59	0.72	0.87
	945	13.4	2.34	0.58	0.71	0.85	12.8	2.68	0.59	0.74	0.88	12.2	3.01	0.61	0.76	0.92	11.5	3.37	0.62	0.79	0.95
	1135	14.2	2.35	0.61	0.76	0.92	13.5	2.69	0.63	0.79	0.95	12.9	3.03	0.64	0.82	0.99	12.2	3.39	0.67	0.86	1
19.4°C	755	13.3	2.33	0.46	0.54	0.62	12.8	2.68	0.46	0.54	0.64	12.2	3.02	0.47	0.55	0.65	11.5	3.37	0.47	0.56	0.67
	945	14.4	2.36	0.47	0.56	0.67	13.8	2.7	0.48	0.57	0.69	13.1	3.03	0.48	0.58	0.71	12.4	3.39	0.49	0.59	0.74
	1135	15.2	2.37	0.48	0.58	0.72	14.5	2.71	0.49	0.59	0.74	13.8	3.05	0.5	0.61	0.77	13.1	3.4	0.5	0.63	0.8
21.7°C	755	14.2	2.35	0.36	0.44	0.51	13.7	2.69	0.37	0.45	0.52	13.1	3.03	0.37	0.45	0.53	12.4	3.39	0.37	0.45	0.54
	945	15.4	2.38	0.37	0.45	0.54	14.7	2.71	0.36	0.46	0.54	14	3.05	0.37	0.47	0.55	13.3	3.41	0.37	0.47	0.56
	1135	16.2	2.39	0.37	0.47	0.56	15.5	2.72	0.37	0.47	0.57	14.8	3.06	0.37	0.48	0.58	14	3.43	0.38	0.49	0.6

ELS120S4D + (2) CH23-68 (2ND STAGE)

Entering Wet Bulb Temperature	Total Air Volume	Outdoor Air Temperature Entering Outdoor Coil																			
		26.7°C					35°C					43.3°C					46°C				
		Total Cool Cap.	Comp. Motor Input	Sensible To Total Ratio (S/T)			Total Cool Cap.	Comp. Motor Input	Sensible To Total Ratio (S/T)			Total Cool Cap.	Comp. Motor Input	Sensible To Total Ratio (S/T)			Total Cool Cap.	Comp. Motor Input	Sensible To Total Ratio (S/T)		
				Dry Bulb					Dry Bulb					Dry Bulb					Dry Bulb		
L/s	kW	kW	24°C	27°C	29°C	kW	kW	24°C	27°C	29°C	kW	kW	24°C	27°C	29°C	kW	kW	24°C	27°C	29°C	
17.2°C	1510	29.7	5.78	0.76	0.90	1.00	27.5	6.86	0.79	0.94	1.00	25.3	8.19	0.82	0.98	1.00	24.5	8.69	0.84	1.00	1.00
	1890	31.2	5.81	0.81	0.97	1.00	29.0	6.89	0.85	1.00	1.00	26.9	8.22	0.89	1.00	1.00	26.3	8.74	0.91	1.00	1.00
	2265	32.6	5.83	0.87	1.00	1.00	30.6	6.92	0.91	1.00	1.00	28.4	8.28	0.96	1.00	1.00	27.6	8.80	0.97	1.00	1.00
19.4°C	1510	31.6	5.81	0.60	0.73	0.87	29.3	6.89	0.61	0.76	0.91	26.9	8.23	0.63	0.80	0.95	26.1	8.73	0.64	0.81	0.97
	1890	33.1	5.84	0.63	0.79	0.94	30.7	6.92	0.65	0.82	0.98	28.1	8.27	0.67	0.86	1.00	27.3	8.78	0.69	0.88	1.00
	2265	34.1	5.86	0.66	0.84	0.99	31.6	6.94	0.68	0.88	1.00	29.0	8.30	0.72	0.93	1.00	28.1	8.82	0.73	0.95	1.00
21.7°C	1510	33.7	5.85	0.45	0.58	0.71	31.4	6.94	0.45	0.60	0.73	28.9	8.29	0.46	0.62	0.77	28.0	8.81	0.46	0.63	0.78
	1890	35.1	5.87	0.46	0.61	0.76	32.7	6.97	0.47	0.63	0.79	30.2	8.34	0.48	0.66	0.84	29.3	8.85	0.48	0.67	0.85
	2265	36.1	5.89	0.47	0.65	0.81	33.8	6.99	0.49	0.67	0.86	31.1	8.36	0.50	0.70	0.90	30.1	8.87	0.50	0.72	0.92

Entering Wet Bulb Temperature	Total Air Volume	Outdoor Air Temperature Entering Outdoor Coil																	
		48°C					50°C					51.7°C							
		Total Cool Cap.	Comp. Motor Input	Sensible To Total Ratio (S/T)			Total Cool Cap.	Comp. Motor Input	Sensible To Total Ratio (S/T)			Total Cool Cap.	Comp. Motor Input	Sensible To Total Ratio (S/T)					
				Dry Bulb					Dry Bulb					Dry Bulb					
L/s	kW	kW	24°C	27°C	29°C	kW	kW	24°C	27°C	29°C	kW	kW	24°C	27°C	29°C				
17.2°C	1510	23.9	9.10	0.85	1.00	1.00	23.4	9.54	0.87	1.00	1.00	22.9	9.95	0.88	1.00	1.00			
	1890	25.7	9.16	0.93	1.00	1.00	25.1	9.61	0.94	1.00	1.00	24.7	10.03	0.95	1.00	1.00			
	2265	27.1	9.22	0.98	1.00	1.00	26.5	9.66	0.99	1.00	1.00	26.0	10.08	1.00	1.00	1.00			
19.4°C	1510	25.5	9.15	0.65	0.82	0.98	24.8	9.58	0.66	0.83	0.99	24.2	10.00	0.66	0.84	0.99			
	1890	26.6	9.19	0.69	0.90	1.00	25.9	9.64	0.70	0.91	1.00	25.3	10.06	0.71	0.92	1.00			
	2265	27.5	9.22	0.74	0.96	1.00	26.8	9.68	0.75	0.97	1.00	26.2	10.10	0.76	0.98	1.00			
21.7°C	1510	27.4	9.23	0.47	0.63	0.79	26.7	9.68	0.47	0.64	0.80	26.2	10.11	0.47	0.64	0.81			
	1890	28.5	9.26	0.49	0.68	0.87	27.9	9.73	0.49	0.69	0.88	27.3	10.14	0.49	0.70	0.89			
	2265	29.4	9.32	0.51	0.73	0.93	28.7	9.77	0.51	0.74	0.94	28.1	10.19	0.52	0.74	0.96			

RATINGS

ONE OUTDOOR UNIT + TWO INDOOR UNITS

NOTE - For Temperatures and Capacities not shown in tables, see bulletin - Cooling Unit Rating Table Correction Factor Data in Miscellaneous Engineering Data section.

ELS120S4D + (2) CX35-60D (1ST STAGE)

Entering Wet Bulb Temperature	Total Air Volume	Outdoor Air Temperature Entering Outdoor Coil																			
		18.3 °C					23.9 °C					29.4 °C					35 °C				
		Total Cool Cap.	Comp. Motor Input	Sensible To Total Ratio (S/T)			Total Cool Cap.	Comp. Motor Input	Sensible To Total Ratio (S/T)			Total Cool Cap.	Comp. Motor Input	Sensible To Total Ratio (S/T)			Total Cool Cap.	Comp. Motor Input	Sensible To Total Ratio (S/T)		
				Dry Bulb					Dry Bulb					Dry Bulb					Dry Bulb		
L/s	kW	kW	24°C	27°C	29°C	kW	kW	24°C	27°C	29°C	kW	kW	24°C	27°C	29°C	kW	kW	24°C	27°C	29°C	
17.2°C	755	12.4	2.31	0.56	0.67	0.79	11.9	2.66	0.57	0.68	0.81	11.4	3	0.58	0.7	0.84	10.8	3.35	0.59	0.72	0.87
	945	13.4	2.34	0.58	0.71	0.85	12.8	2.68	0.59	0.73	0.88	12.3	3.02	0.6	0.75	0.91	11.6	3.37	0.62	0.78	0.95
	1135	14.2	2.35	0.61	0.76	0.91	13.5	2.69	0.62	0.78	0.95	12.9	3.03	0.64	0.81	0.98	12.2	3.39	0.66	0.85	1
19.4°C	755	13.2	2.33	0.46	0.54	0.62	12.7	2.68	0.46	0.54	0.64	12.2	3.02	0.47	0.55	0.65	11.6	3.37	0.47	0.56	0.67
	945	14.2	2.35	0.47	0.56	0.66	13.7	2.7	0.48	0.57	0.69	13.1	3.03	0.48	0.58	0.71	12.5	3.39	0.49	0.59	0.73
	1135	15	2.37	0.48	0.58	0.71	14.5	2.71	0.49	0.59	0.73	13.8	3.04	0.5	0.61	0.76	13.1	3.41	0.5	0.63	0.79
21.7°C	755	14	2.35	0.37	0.44	0.51	13.5	2.69	0.37	0.45	0.52	13	3.03	0.37	0.45	0.53	12.3	3.39	0.37	0.45	0.53
	945	15.1	2.37	0.37	0.45	0.53	14.6	2.71	0.37	0.46	0.54	14	3.05	0.37	0.47	0.55	13.3	3.41	0.37	0.47	0.56
	1135	16	2.39	0.37	0.47	0.56	15.4	2.72	0.38	0.47	0.57	14.7	3.06	0.38	0.48	0.58	14	3.43	0.38	0.49	0.59

ELS120S4D + (2) CX35-60D (2ND STAGE)

Entering Wet Bulb Temperature	Total Air Volume	Outdoor Air Temperature Entering Outdoor Coil																			
		26.7 °C					35 °C					43.3 °C					46 °C				
		Total Cool Cap.	Comp. Motor Input	Sensible To Total Ratio (S/T)			Total Cool Cap.	Comp. Motor Input	Sensible To Total Ratio (S/T)			Total Cool Cap.	Comp. Motor Input	Sensible To Total Ratio (S/T)			Total Cool Cap.	Comp. Motor Input	Sensible To Total Ratio (S/T)		
				Dry Bulb					Dry Bulb					Dry Bulb					Dry Bulb		
L/s	kW	kW	24°C	27°C	29°C	kW	kW	24°C	27°C	29°C	kW	kW	24°C	27°C	29°C	kW	kW	24°C	27°C	29°C	
17.2°C	1510	29.8	5.79	0.75	0.89	1.00	27.6	6.86	0.78	0.93	1.00	25.3	8.18	0.81	0.98	1.00	24.5	8.69	0.83	0.99	1.00
	1890	31.3	5.81	0.80	0.96	1.00	29.0	6.89	0.83	1.00	1.00	26.9	8.23	0.88	1.00	1.00	26.2	8.73	0.90	1.00	1.00
	2265	32.5	5.83	0.84	1.00	1.00	30.5	6.92	0.89	1.00	1.00	28.3	8.28	0.94	1.00	1.00	27.6	8.79	0.96	1.00	1.00
19.4°C	1510	31.5	5.81	0.59	0.72	0.85	29.4	6.89	0.61	0.75	0.89	27.0	8.24	0.63	0.78	0.94	26.2	8.74	0.63	0.80	0.96
	1890	33.1	5.84	0.62	0.77	0.92	30.8	6.93	0.64	0.81	0.97	28.3	8.27	0.66	0.85	1.00	27.4	8.78	0.67	0.86	1.00
	2265	34.3	5.86	0.65	0.82	0.98	31.8	6.95	0.67	0.86	1.00	29.2	8.30	0.70	0.91	1.00	28.3	8.82	0.71	0.92	1.00
21.7°C	1510	33.5	5.84	0.45	0.57	0.70	31.2	6.94	0.45	0.59	0.72	28.9	8.30	0.46	0.61	0.75	28.1	8.81	0.46	0.62	0.77
	1890	35.1	5.87	0.46	0.61	0.75	32.8	6.97	0.47	0.63	0.78	30.2	8.34	0.48	0.65	0.82	29.4	8.86	0.48	0.66	0.83
	2265	36.2	5.89	0.47	0.64	0.79	33.7	6.99	0.48	0.66	0.83	31.1	8.37	0.49	0.69	0.87	30.2	8.89	0.50	0.70	0.89

Entering Wet Bulb Temperature	Total Air Volume	Outdoor Air Temperature Entering Outdoor Coil																	
		48 °C					50 °C					51.7 °C							
		Total Cool Cap.	Comp. Motor Input	Sensible To Total Ratio (S/T)			Total Cool Cap.	Comp. Motor Input	Sensible To Total Ratio (S/T)			Total Cool Cap.	Comp. Motor Input	Sensible To Total Ratio (S/T)					
				Dry Bulb					Dry Bulb					Dry Bulb					
L/s	kW	kW	24°C	27°C	29°C	kW	kW	24°C	27°C	29°C	kW	kW	24°C	27°C	29°C				
17.2°C	1510	23.9	9.10	0.84	1.00	1.00	23.4	9.54	0.85	1.00	1.00	22.9	9.96	0.86	1.00	1.00			
	1890	25.6	9.15	0.91	1.00	1.00	25.1	9.61	0.92	1.00	1.00	24.6	10.02	0.93	1.00	1.00			
	2265	27.1	9.22	0.97	1.00	1.00	26.5	9.67	0.98	1.00	1.00	25.9	10.07	0.99	1.00	1.00			
19.4°C	1510	25.6	9.16	0.64	0.81	0.97	25.0	9.61	0.65	0.82	0.98	24.4	10.02	0.65	0.83	0.99			
	1890	26.8	9.20	0.68	0.88	1.00	26.1	9.65	0.69	0.89	1.00	25.5	10.06	0.70	0.90	1.00			
	2265	27.6	9.24	0.72	0.94	1.00	26.9	9.69	0.73	0.95	1.00	26.3	10.11	0.74	0.97	1.00			
21.7°C	1510	27.5	9.23	0.47	0.62	0.78	26.8	9.69	0.47	0.63	0.79	26.3	10.11	0.47	0.64	0.79			
	1890	28.7	9.27	0.48	0.67	0.84	28.0	9.73	0.49	0.68	0.86	27.4	10.16	0.49	0.68	0.87			
	2265	29.6	9.32	0.50	0.71	0.91	28.9	9.78	0.51	0.72	0.92	28.3	10.21	0.51	0.73	0.94			

RATINGS

ONE OUTDOOR UNIT + TWO INDOOR UNITS

NOTE - For Temperatures and Capacities not shown in tables, see bulletin - Cooling Unit Rating Table Correction Factor Data in Miscellaneous Engineering Data section.

ELS120S4D + (2) CX35-60C (1ST STAGE)

Entering Wet Bulb Temperature	Total Air Volume	Outdoor Air Temperature Entering Outdoor Coil																			
		18.3°C					23.9°C					29.4°C					35°C				
		Total Cool Cap.	Comp. Motor Input	Sensible To Total Ratio (S/T)			Total Cool Cap.	Comp. Motor Input	Sensible To Total Ratio (S/T)			Total Cool Cap.	Comp. Motor Input	Sensible To Total Ratio (S/T)			Total Cool Cap.	Comp. Motor Input	Sensible To Total Ratio (S/T)		
				Dry Bulb					Dry Bulb					Dry Bulb					Dry Bulb		
		L/s	kW	kW	24°C	27°C	29°C	kW	kW	24°C	27°C	29°C	kW	kW	24°C	27°C	29°C	kW	kW	24°C	27°C
17.2°C	755	12.6	2.32	0.56	0.67	0.79	12.1	2.67	0.57	0.68	0.81	11.5	3	0.58	0.7	0.84	10.9	3.36	0.59	0.72	0.87
	945	13.7	2.34	0.58	0.71	0.86	13	2.68	0.59	0.73	0.89	12.4	3.02	0.61	0.76	0.92	11.7	3.38	0.62	0.79	0.96
	1135	14.4	2.36	0.61	0.76	0.93	13.8	2.7	0.63	0.79	0.96	13.1	3.03	0.64	0.82	1	12.3	3.39	0.67	0.85	1
19.4°C	755	13.5	2.34	0.46	0.54	0.62	12.9	2.68	0.46	0.54	0.64	12.3	3.02	0.47	0.55	0.65	11.7	3.37	0.47	0.56	0.67
	945	14.5	2.36	0.47	0.56	0.67	13.9	2.7	0.47	0.57	0.69	13.2	3.04	0.48	0.58	0.71	12.6	3.39	0.49	0.59	0.73
	1135	15.4	2.38	0.48	0.58	0.72	14.7	2.71	0.49	0.59	0.74	14	3.05	0.49	0.61	0.77	13.2	3.41	0.5	0.63	0.8
21.7°C	755	14.3	2.35	0.37	0.44	0.51	13.7	2.69	0.36	0.44	0.52	13.1	3.03	0.37	0.45	0.53	12.4	3.39	0.37	0.45	0.53
	945	15.4	2.38	0.37	0.45	0.53	14.8	2.71	0.37	0.46	0.54	14.1	3.05	0.37	0.46	0.55	13.4	3.41	0.37	0.47	0.56
	1135	16.3	2.39	0.37	0.47	0.56	15.6	2.73	0.37	0.47	0.57	14.9	3.06	0.38	0.48	0.58	14.1	3.43	0.38	0.49	0.59

ELS120S4D + (2) CX35-60C (2ND STAGE)

Entering Wet Bulb Temperature	Total Air Volume	Outdoor Air Temperature Entering Outdoor Coil																			
		26.7°C					35°C					43.3°C					46°C				
		Total Cool Cap.	Comp. Motor Input	Sensible To Total Ratio (S/T)			Total Cool Cap.	Comp. Motor Input	Sensible To Total Ratio (S/T)			Total Cool Cap.	Comp. Motor Input	Sensible To Total Ratio (S/T)			Total Cool Cap.	Comp. Motor Input	Sensible To Total Ratio (S/T)		
				Dry Bulb					Dry Bulb					Dry Bulb					Dry Bulb		
		L/s	kW	kW	24°C	27°C	29°C	kW	kW	24°C	27°C	29°C	kW	kW	24°C	27°C	29°C	kW	kW	24°C	27°C
17.2°C	1510	29.8	5.79	0.76	0.91	1.00	27.5	6.87	0.79	0.95	1.00	25.1	8.19	0.82	0.99	1.00	24.3	8.69	0.84	1.00	1.00
	1890	31.3	5.82	0.81	0.98	1.00	29.0	6.90	0.85	1.00	1.00	26.9	8.24	0.89	1.00	1.00	26.2	8.74	0.91	1.00	1.00
	2265	32.6	5.84	0.87	1.00	1.00	30.6	6.93	0.91	1.00	1.00	28.3	8.29	0.96	1.00	1.00	27.6	8.81	0.98	1.00	1.00
19.4°C	1510	31.6	5.82	0.59	0.73	0.87	29.4	6.91	0.61	0.76	0.91	26.9	8.24	0.63	0.79	0.95	26.1	8.75	0.64	0.81	0.97
	1890	33.1	5.85	0.63	0.79	0.94	30.8	6.94	0.65	0.82	0.99	28.1	8.28	0.67	0.86	1.00	27.2	8.80	0.68	0.88	1.00
	2265	34.2	5.87	0.66	0.84	1.00	31.7	6.96	0.68	0.88	1.00	29.0	8.31	0.71	0.93	1.00	28.1	8.82	0.73	0.95	1.00
21.7°C	1510	33.4	5.85	0.45	0.58	0.70	31.2	6.94	0.45	0.59	0.73	28.7	8.30	0.46	0.61	0.76	27.9	8.81	0.47	0.62	0.78
	1890	35.1	5.88	0.46	0.62	0.76	32.7	6.98	0.47	0.63	0.79	30.1	8.35	0.48	0.66	0.83	29.2	8.87	0.48	0.67	0.85
	2265	36.1	5.90	0.48	0.65	0.81	33.7	7.00	0.49	0.67	0.85	31.1	8.38	0.50	0.70	0.90	30.1	8.90	0.50	0.71	0.92

Entering Wet Bulb Temperature	Total Air Volume	Outdoor Air Temperature Entering Outdoor Coil																	
		48°C					50°C					51.7°C							
		Total Cool Cap.	Comp. Motor Input	Sensible To Total Ratio (S/T)			Total Cool Cap.	Comp. Motor Input	Sensible To Total Ratio (S/T)			Total Cool Cap.	Comp. Motor Input	Sensible To Total Ratio (S/T)					
				Dry Bulb					Dry Bulb					Dry Bulb					
		L/s	kW	kW	24°C	27°C	29°C	kW	kW	24°C	27°C	29°C	kW	kW	24°C	27°C	29°C		
17.2°C	1510	23.8	9.10	0.85	1.00	1.00	23.3	9.55	0.86	1.00	1.00	22.8	9.96	0.87	1.00	1.00			
	1890	25.6	9.17	0.93	1.00	1.00	25.0	9.62	0.94	1.00	1.00	24.5	10.04	0.95	1.00	1.00			
	2265	27.0	9.23	0.99	1.00	1.00	26.4	9.69	1.00	1.00	1.00	25.9	10.10	1.00	1.00	1.00			
19.4°C	1510	25.5	9.16	0.65	0.82	0.99	24.8	9.61	0.65	0.83	1.00	24.2	10.02	0.66	0.84	1.00			
	1890	26.6	9.21	0.69	0.89	1.00	25.8	9.66	0.70	0.91	1.00	25.3	10.08	0.71	0.92	1.00			
	2265	27.4	9.24	0.74	0.97	1.00	26.7	9.69	0.75	0.98	1.00	26.1	10.11	0.75	0.99	1.00			
21.7°C	1510	27.3	9.23	0.47	0.63	0.79	26.6	9.68	0.47	0.64	0.80	26.0	10.10	0.47	0.64	0.81			
	1890	28.5	9.29	0.49	0.68	0.86	27.8	9.75	0.49	0.68	0.87	27.2	10.17	0.49	0.69	0.88			
	2265	29.4	9.34	0.51	0.72	0.93	28.6	9.78	0.51	0.73	0.95	28.0	10.21	0.51	0.74	0.97			

RATINGS

ONE OUTDOOR UNIT + TWO INDOOR UNITS

NOTE - For Temperatures and Capacities not shown in tables, see bulletin - Cooling Unit Rating Table Correction Factor Data in Miscellaneous Engineering Data section.

ELS180S4D + (2) ELA090S4D (1ST STAGE)

Entering Wet Bulb Temperature	Total Air Volume	Outdoor Air Temperature Entering Outdoor Coil																							
		18.3°C						23.9°C						29.4°C						35°C					
		Total Cool Cap.	Comp. Motor Input	Sensible To Total Ratio (S/T)			Total Cool Cap.	Comp. Motor Input	Sensible To Total Ratio (S/T)			Total Cool Cap.	Comp. Motor Input	Sensible To Total Ratio (S/T)			Total Cool Cap.	Comp. Motor Input	Sensible To Total Ratio (S/T)						
				Dry Bulb					Dry Bulb					Dry Bulb					Dry Bulb						
L/s	kW	kW	24°C	27°C	29°C	kW	kW	24°C	27°C	29°C	kW	kW	24°C	27°C	29°C	kW	kW	24°C	27°C	29°C					
17.2°C	1133	24.9	3.86	0.73	0.87	0.99	24.1	4.27	0.74	0.88	1	23.2	4.74	0.76	0.9	1	22.2	5.26	0.77	0.92	1				
	1416	26.1	3.91	0.78	0.94	1	25.2	4.32	0.8	0.96	1	24.2	4.79	0.81	0.97	1	23.1	5.3	0.83	0.99	1				
	1699	27	3.96	0.84	0.99	1	26.1	4.37	0.85	1	1	25.1	4.82	0.86	1	1	24.1	5.35	0.89	1	1				
19.4°C	1133	26.4	3.93	0.58	0.71	0.83	25.5	4.34	0.58	0.71	0.85	24.6	4.8	0.6	0.73	0.86	23.4	5.32	0.6	0.74	0.89				
	1416	27.5	3.98	0.61	0.76	0.91	26.6	4.39	0.62	0.78	0.92	25.6	4.85	0.63	0.79	0.94	24.4	5.36	0.64	0.81	0.97				
	1699	28.3	4.03	0.64	0.81	0.97	27.3	4.43	0.66	0.83	0.99	26.2	4.88	0.66	0.85	1	25	5.4	0.68	0.87	1				
21.7°C	1133	27.9	4	0.44	0.56	0.69	26.9	4.41	0.44	0.56	0.69	26	4.87	0.45	0.58	0.71	24.8	5.38	0.45	0.59	0.72				
	1416	29	4.06	0.46	0.59	0.73	28.1	4.47	0.45	0.61	0.75	27	4.92	0.46	0.62	0.77	25.7	5.44	0.47	0.63	0.78				
	1699	29.9	4.11	0.47	0.63	0.79	28.8	4.51	0.48	0.64	0.81	27.7	4.96	0.48	0.65	0.83	26.4	5.47	0.48	0.66	0.85				

ELS180S4D + (2) ELA090S4D (2ND STAGE)

Entering Wet Bulb Temperature	Total Air Volume	Outdoor Air Temperature Entering Outdoor Coil																							
		26.7°C						35°C						43.3°C						46°C					
		Total Cool Cap.	Comp. Motor Input	Sensible To Total Ratio (S/T)			Total Cool Cap.	Comp. Motor Input	Sensible To Total Ratio (S/T)			Total Cool Cap.	Comp. Motor Input	Sensible To Total Ratio (S/T)			Total Cool Cap.	Comp. Motor Input	Sensible To Total Ratio (S/T)						
				Dry Bulb					Dry Bulb					Dry Bulb					Dry Bulb						
L/s	kW	kW	24°C	27°C	29°C	kW	kW	24°C	27°C	29°C	kW	kW	24°C	27°C	29°C	kW	kW	24°C	27°C	29°C					
17.2°C	2265	47.9	9.08	0.75	0.89	1	44.8	10.59	0.77	0.92	1	41.3	12.43	0.8	0.96	1	39.3	13.18	0.81	0.97	1.00				
	2830	49.9	9.18	0.81	0.97	1	46.7	10.69	0.83	1	1	43.4	12.54	0.87	1	1	41.4	13.37	0.88	1.00	1.00				
	3400	51.8	9.28	0.86	1	1	48.8	10.81	0.89	1	1	45.5	12.65	0.93	1	1	43.3	13.53	0.93	1.00	1.00				
19.4°C	2265	50.8	9.23	0.59	0.73	0.85	47.4	10.72	0.6	0.75	0.89	43.8	12.56	0.62	0.78	0.93	41.7	13.40	0.63	0.79	0.94				
	2830	52.8	9.33	0.63	0.79	0.94	49.2	10.83	0.64	0.81	0.97	45.3	12.65	0.66	0.85	1	43.4	13.54	0.67	0.85	1.00				
	3400	54.3	9.41	0.66	0.84	1	50.5	10.9	0.68	0.87	1	46.5	12.71	0.7	0.91	1	44.5	13.64	0.71	0.91	1.00				
21.7°C	2265	53.6	9.37	0.44	0.58	0.7	50.1	10.87	0.45	0.59	0.73	46.2	12.7	0.46	0.61	0.76	44.3	13.61	0.45	0.61	0.76				
	2830	55.7	9.49	0.46	0.61	0.76	52	10.98	0.47	0.63	0.79	47.9	12.8	0.48	0.65	0.82	46.0	13.78	0.46	0.66	0.83				
	3400	57.2	9.57	0.48	0.65	0.82	53.3	11.05	0.48	0.67	0.85	49	12.86	0.49	0.7	0.89	47.2	13.88	0.49	0.70	0.89				

Entering Wet Bulb Temperature	Total Air Volume	Outdoor Air Temperature Entering Outdoor Coil																		
		48°C						50°C						51.7°C						
		Total Cool Cap.	Comp. Motor Input	Sensible To Total Ratio (S/T)			Total Cool Cap.	Comp. Motor Input	Sensible To Total Ratio (S/T)			Total Cool Cap.	Comp. Motor Input	Sensible To Total Ratio (S/T)						
				Dry Bulb					Dry Bulb					Dry Bulb						
L/s	kW	kW	24°C	27°C	29°C	kW	kW	24°C	27°C	29°C	kW	kW	24°C	27°C	29°C	kW	kW	24°C	27°C	29°C
17.2°C	2265	38.4	13.67	0.82	0.98	1.00	37.4	14.17	0.83	0.99	1.00	37.4	14.7	0.84	1	1				
	2830	40.4	13.86	0.89	1.00	1.00	39.6	14.37	0.90	1.00	1.00	39.7	14.84	0.92	1	1				
	3400	42.4	14.03	0.94	1.00	1.00	41.4	14.54	0.96	1.00	1.00	41.4	14.92	0.98	1	1				
19.4°C	2265	40.7	13.88	0.63	0.80	0.95	39.7	14.39	0.64	0.81	0.96	39.5	14.82	0.64	0.82	0.98				
	2830	42.3	14.02	0.67	0.86	1.00	41.2	14.51	0.68	0.88	1.00	40.9	14.88	0.69	0.9	1				
	3400	43.5	14.12	0.72	0.92	1.00	42.5	14.63	0.72	0.93	1.00	41.8	14.95	0.74	0.97	1				
21.7°C	2265	43.3	14.11	0.45	0.62	0.77	42.2	14.60	0.45	0.62	0.78	41.9	14.95	0.47	0.63	0.79				
	2830	44.9	14.26	0.47	0.66	0.84	43.8	14.75	0.47	0.67	0.85	43.2	15.03	0.49	0.69	0.87				
	3400	46.0	14.36	0.49	0.71	0.90	44.9	14.86	0.50	0.72	0.91	44.2	15.09	0.51	0.74	0.95				

RATINGS

ONE OUTDOOR UNIT + TWO INDOOR UNITS

NOTE - For Temperatures and Capacities not shown in tables, see bulletin - Cooling Unit Rating Table Correction Factor Data in Miscellaneous Engineering Data section.

ELS240S4D + (2) ELA120S4D (1ST STAGE)

Entering Wet Bulb Temperature	Total Air Volume	Outdoor Air Temperature Entering Outdoor Coil																							
		18.3 °C						23.9 °C						29.4 °C						35 °C					
		Total Cool Cap.	Comp. Motor Input	Sensible To Total Ratio (S/T)			Total Cool Cap.	Comp. Motor Input	Sensible To Total Ratio (S/T)			Total Cool Cap.	Comp. Motor Input	Sensible To Total Ratio (S/T)			Total Cool Cap.	Comp. Motor Input	Sensible To Total Ratio (S/T)						
				Dry Bulb					Dry Bulb					Dry Bulb					Dry Bulb						
L/s	kW	kW	24°C	27°C	29°C	kW	kW	24°C	27°C	29°C	kW	kW	24°C	27°C	29°C	kW	kW	24°C	27°C	29°C					
17.2°C	755	20.7	4.35	0.57	0.64	0.71	20.2	4.85	0.57	0.64	0.71	19.5	5.42	0.57	0.64	0.72	18.9	6.1	0.57	0.65	0.72				
	944	23	4.42	0.57	0.65	0.73	22.2	4.91	0.57	0.65	0.73	21.5	5.49	0.57	0.65	0.76	20.7	6.14	0.61	0.69	0.77				
	1133	24.6	4.47	0.61	0.69	0.77	23.8	4.96	0.61	0.69	0.77	23.1	5.54	0.61	0.7	0.78	22.2	6.19	0.62	0.71	0.79				
19.4°C	755	22.2	4.39	0.48	0.54	0.6	21.7	4.9	0.48	0.54	0.6	21	5.47	0.47	0.54	0.6	20.2	6.13	0.46	0.53	0.65				
	944	24.4	4.47	0.52	0.58	0.65	23.6	4.96	0.51	0.58	0.64	22.8	5.53	0.51	0.58	0.65	22	6.19	0.51	0.58	0.65				
	1133	26.1	4.53	0.51	0.58	0.65	25.4	5.02	0.51	0.58	0.66	24.6	5.6	0.51	0.59	0.66	23.7	6.26	0.51	0.59	0.67				
21.7°C	755	23.7	4.45	0.38	0.44	0.5	22.9	4.94	0.45	0.5	0.55	22.1	5.5	0.44	0.49	0.55	21.3	6.16	0.43	0.49	0.54				
	944	25.9	4.52	0.42	0.48	0.54	25.1	5.01	0.42	0.48	0.55	24.4	5.58	0.42	0.49	0.55	23.5	6.24	0.42	0.49	0.55				
	1133	27.9	4.6	0.42	0.49	0.55	27.1	5.09	0.42	0.49	0.55	26.2	5.66	0.42	0.49	0.56	25.3	6.31	0.41	0.49	0.56				

ELS240S4D + (2) ELA120S4D (2ND STAGE)

Entering Wet Bulb Temperature	Total Air Volume	Outdoor Air Temperature Entering Outdoor Coil																							
		26.7 °C						35 °C						43.3 °C						46 °C					
		Total Cool Cap.	Comp. Motor Input	Sensible To Total Ratio (S/T)			Total Cool Cap.	Comp. Motor Input	Sensible To Total Ratio (S/T)			Total Cool Cap.	Comp. Motor Input	Sensible To Total Ratio (S/T)			Total Cool Cap.	Comp. Motor Input	Sensible To Total Ratio (S/T)						
				Dry Bulb					Dry Bulb					Dry Bulb					Dry Bulb						
L/s	kW	kW	24°C	27°C	29°C	kW	kW	24°C	27°C	29°C	kW	kW	24°C	27°C	29°C	kW	kW	24°C	27°C	29°C					
17.2°C	3020	51.2	10.66	0.65	0.75	0.84	48.2	12.54	0.66	0.76	0.86	44.8	14.87	0.67	0.78	0.89	51.2	16.56	0.83	1.00	1.00				
	3775	54.9	10.81	0.68	0.79	0.89	51.6	12.69	0.69	0.81	0.92	47.8	14.99	0.71	0.83	0.95	54.3	16.72	0.90	1.00	1.00				
	4530	57.6	10.94	0.7	0.83	0.95	54	12.81	0.72	0.85	0.98	49.9	15.08	0.74	0.89	1	56.8	16.88	0.97	1.00	1.00				
19.4°C	3020	54.6	10.81	0.53	0.62	0.71	51.4	12.68	0.54	0.63	0.73	47.8	14.98	0.54	0.65	0.75	54.6	16.74	0.64	0.81	0.97				
	3775	58.5	10.98	0.55	0.65	0.75	54.9	12.84	0.55	0.66	0.77	50.8	15.12	0.56	0.68	0.8	56.3	16.83	0.68	0.88	1.00				
	4530	61.4	11.12	0.56	0.68	0.79	57.5	12.95	0.57	0.7	0.82	53.1	15.23	0.58	0.72	0.85	57.9	16.94	0.73	0.95	1.00				
21.7°C	3020	58	10.96	0.43	0.51	0.6	54.7	12.82	0.43	0.52	0.61	50.9	15.11	0.43	0.52	0.62	58.0	16.95	0.46	0.63	0.78				
	3775	62	11.15	0.43	0.53	0.62	58.4	12.98	0.43	0.54	0.64	54.2	15.28	0.43	0.55	0.65	60.1	17.06	0.48	0.67	0.86				
	4530	65.1	11.3	0.43	0.55	0.65	60.8	13.11	0.44	0.55	0.67	56.4	15.39	0.44	0.57	0.69	61.6	17.19	0.49	0.72	0.92				

Entering Wet Bulb Temperature	Total Air Volume	Outdoor Air Temperature Entering Outdoor Coil																	
		48 °C						50 °C						51.7 °C					
		Total Cool Cap.	Comp. Motor Input	Sensible To Total Ratio (S/T)			Total Cool Cap.	Comp. Motor Input	Sensible To Total Ratio (S/T)			Total Cool Cap.	Comp. Motor Input	Sensible To Total Ratio (S/T)					
				Dry Bulb					Dry Bulb					Dry Bulb					
L/s	kW	kW	24°C	27°C	29°C	kW	kW	24°C	27°C	29°C	kW	kW	24°C	27°C	29°C				
17.2°C	3020	49.8	17.21	0.85	1.00	1.00	48.6	17.94	0.86	1.00	1.00	40.9	17.68	0.69	0.81	0.93			
	3775	53.1	17.42	0.91	1.00	1.00	51.7	18.11	0.93	1.00	1.00	43.4	17.79	0.73	0.87	1			
	4530	55.5	17.53	0.98	1.00	1.00	54.2	18.26	0.99	1.00	1.00	45.3	17.9	0.77	0.93	1			
19.4°C	3020	53.1	17.42	0.65	0.82	0.98	51.6	18.11	0.65	0.83	0.99	43.7	17.81	0.56	0.67	0.78			
	3775	54.9	17.50	0.69	0.89	1.00	53.4	18.22	0.70	0.91	1.00	46.2	17.94	0.58	0.71	0.83			
	4530	56.2	17.59	0.73	0.96	1.00	54.6	18.29	0.74	0.98	1.00	48.2	18.04	0.6	0.75	0.89			
21.7°C	3020	56.5	17.62	0.47	0.64	0.79	55.0	18.30	0.46	0.64	0.80	46.6	17.97	0.43	0.54	0.64			
	3775	58.4	17.71	0.47	0.68	0.87	56.9	18.42	0.48	0.68	0.88	49.2	18.09	0.44	0.56	0.68			
	4530	60.0	17.84	0.49	0.73	0.94	58.2	18.50	0.50	0.73	0.96	51.3	18.2	0.45	0.59	0.72			

RATINGS

TWO OUTDOOR UNIT + ONE INDOOR UNIT

NOTE - For Temperatures and Capacities not shown in tables, see bulletin - Cooling Unit Rating Table Correction Factor Data in Miscellaneous Engineering Data section.

(2) ELS090S4D + ELA180S4D (1ST STAGE)

Entering Wet Bulb Temperature	Total Air Volume	Outdoor Air Temperature Entering Outdoor Coil																							
		18.3°C						23.9°C						29.4°C						35°C					
		Total Cool Cap.	Comp. Motor Input	Sensible To Total Ratio (S/T)			Total Cool Cap.	Comp. Motor Input	Sensible To Total Ratio (S/T)			Total Cool Cap.	Comp. Motor Input	Sensible To Total Ratio (S/T)			Total Cool Cap.	Comp. Motor Input	Sensible To Total Ratio (S/T)						
				Dry Bulb					Dry Bulb					Dry Bulb					Dry Bulb						
L/s	kW	kW	24°C	27°C	29°C	kW	kW	24°C	27°C	29°C	kW	kW	24°C	27°C	29°C	kW	kW	24°C	27°C	29°C					
17.2°C	1510	34.8	4.53	0.74	0.87	0.99	33.4	5.31	0.76	0.89	1	31.9	6.18	0.77	0.91	1	30.3	7.14	0.79	0.93	1				
	1890	36.7	4.52	0.79	0.94	1	35.2	5.3	0.81	0.96	1	33.6	6.17	0.82	0.98	1	31.8	7.13	0.84	1	1				
	2265	38.1	4.51	0.84	0.99	1	36.5	5.29	0.85	1	1	35	6.16	0.88	1	1	33.4	7.12	0.9	1	1				
19.4°C	1510	37	4.52	0.58	0.72	0.84	35.6	5.3	0.59	0.73	0.86	34	6.17	0.6	0.74	0.88	32.3	7.13	0.61	0.76	0.9				
	1890	39	4.5	0.61	0.76	0.9	37.4	5.29	0.62	0.78	0.92	35.7	6.16	0.63	0.8	0.94	33.8	7.12	0.65	0.82	0.97				
	2265	40.5	4.5	0.64	0.81	0.96	38.7	5.28	0.65	0.83	0.98	36.8	6.15	0.67	0.85	1	34.8	7.12	0.68	0.87	1				
21.7°C	1510	39.4	4.5	0.43	0.56	0.69	37.9	5.28	0.44	0.57	0.7	36.2	6.15	0.44	0.58	0.72	34.4	7.12	0.44	0.59	0.73				
	1890	41.5	4.49	0.44	0.6	0.74	39.7	5.28	0.45	0.6	0.75	37.9	6.15	0.45	0.62	0.77	36	7.11	0.46	0.63	0.79				
	2265	43	4.48	0.46	0.63	0.79	41.1	5.27	0.46	0.64	0.8	39.1	6.14	0.47	0.65	0.82	37	7.11	0.48	0.67	0.85				

(2) ELS090S4D + ELA180S4D (2ND STAGE)

Entering Wet Bulb Temperature	Total Air Volume	Outdoor Air Temperature Entering Outdoor Coil																							
		26.7°C						35°C						43.3°C						46°C					
		Total Cool Cap.	Comp. Motor Input	Sensible To Total Ratio (S/T)			Total Cool Cap.	Comp. Motor Input	Sensible To Total Ratio (S/T)			Total Cool Cap.	Comp. Motor Input	Sensible To Total Ratio (S/T)			Total Cool Cap.	Comp. Motor Input	Sensible To Total Ratio (S/T)						
				Dry Bulb					Dry Bulb					Dry Bulb					Dry Bulb						
L/s	kW	kW	24°C	27°C	29°C	kW	kW	24°C	27°C	29°C	kW	kW	24°C	27°C	29°C	kW	kW	24°C	27°C	29°C					
17.2°C	2265	46.9	9.32	0.76	0.9	1	43.8	10.83	0.78	0.93	1	40.4	12.58	0.81	0.96	1	39.3	13.18	0.81	0.97	1.00				
	2830	49.1	9.47	0.81	0.96	1	45.8	10.98	0.84	0.99	1	42.4	12.74	0.87	1	1	41.4	13.37	0.88	1.00	1.00				
	3400	50.8	9.6	0.86	1	1	47.8	11.13	0.89	1	1	44.4	12.91	0.92	1	1	43.3	13.53	0.93	1.00	1.00				
19.4°C	2265	49.8	9.52	0.59	0.73	0.86	46.5	11.03	0.6	0.76	0.89	43	12.79	0.62	0.78	0.93	41.7	13.40	0.63	0.79	0.94				
	2830	52	9.68	0.62	0.79	0.93	48.5	11.19	0.64	0.81	0.96	44.6	12.93	0.66	0.85	0.99	43.4	13.54	0.67	0.85	1.00				
	3400	53.6	9.8	0.66	0.84	0.98	49.9	11.3	0.68	0.87	1	46	13.05	0.7	0.9	1	44.5	13.64	0.71	0.91	1.00				
21.7°C	2265	52.8	9.74	0.43	0.57	0.71	49.3	11.25	0.44	0.59	0.73	45.6	13.01	0.45	0.61	0.76	44.3	13.61	0.45	0.61	0.76				
	2830	55.1	9.9	0.44	0.61	0.76	51.4	11.42	0.45	0.63	0.79	47.3	13.16	0.46	0.65	0.82	46.0	13.78	0.46	0.66	0.83				
	3400	56.7	10.02	0.46	0.65	0.81	52.8	11.54	0.47	0.67	0.84	48.6	13.28	0.49	0.69	0.88	47.2	13.88	0.49	0.70	0.89				

Entering Wet Bulb Temperature	Total Air Volume	Outdoor Air Temperature Entering Outdoor Coil																	
		48°C						50°C						51.7°C					
		Total Cool Cap.	Comp. Motor Input	Sensible To Total Ratio (S/T)			Total Cool Cap.	Comp. Motor Input	Sensible To Total Ratio (S/T)			Total Cool Cap.	Comp. Motor Input	Sensible To Total Ratio (S/T)					
				Dry Bulb					Dry Bulb					Dry Bulb					
L/s	kW	kW	24°C	27°C	29°C	kW	kW	24°C	27°C	29°C	kW	kW	24°C	27°C	29°C				
17.2°C	2265	38.4	13.67	0.82	0.98	1.00	37.4	14.17	0.83	0.99	1.00	36.6	14.63	0.85	1	1			
	2830	40.4	13.86	0.89	1.00	1.00	39.6	14.37	0.90	1.00	1.00	38.8	14.84	0.91	1	1			
	3400	42.4	14.03	0.94	1.00	1.00	41.4	14.54	0.96	1.00	1.00	40.6	14.99	0.97	1	1			
19.4°C	2265	40.7	13.88	0.63	0.80	0.95	39.7	14.39	0.64	0.81	0.96	38.8	14.82	0.65	0.82	0.97			
	2830	42.3	14.02	0.67	0.86	1.00	41.2	14.51	0.68	0.88	1.00	40.3	14.96	0.7	0.89	1			
	3400	43.5	14.12	0.72	0.92	1.00	42.5	14.63	0.72	0.93	1.00	41.4	15.07	0.74	0.95	1			
21.7°C	2265	43.3	14.11	0.45	0.62	0.77	42.2	14.60	0.45	0.62	0.78	41.3	15.06	0.46	0.64	0.8			
	2830	44.9	14.26	0.47	0.66	0.84	43.8	14.75	0.47	0.67	0.85	42.8	15.2	0.49	0.68	0.87			
	3400	46.0	14.36	0.49	0.71	0.90	44.9	14.86	0.50	0.72	0.91	43.8	15.3	0.51	0.73	0.93			

RATINGS

TWO OUTDOOR UNIT + ONE INDOOR UNIT

NOTE - For Temperatures and Capacities not shown in tables, see bulletin - Cooling Unit Rating Table Correction Factor Data in Miscellaneous Engineering Data section.

(2) ELS120S4S + ELA240S4D (1ST STAGE)

Entering Wet Bulb Temperature	Total Air Volume	Outdoor Air Temperature Entering Outdoor Coil																			
		18.3°C					23.9°C					29.4°C					35°C				
		Total Cool Cap.	Comp. Motor Input	Sensible To Total Ratio (S/T)			Total Cool Cap.	Comp. Motor Input	Sensible To Total Ratio (S/T)			Total Cool Cap.	Comp. Motor Input	Sensible To Total Ratio (S/T)			Total Cool Cap.	Comp. Motor Input	Sensible To Total Ratio (S/T)		
				Dry Bulb					Dry Bulb					Dry Bulb					Dry Bulb		
		L/s	kW	kW	24°C	27°C	29°C	kW	kW	24°C	27°C	29°C	kW	kW	24°C	27°C	29°C	kW	kW	24°C	27°C
17.2°C	2125	45.7	5.56	0.74	0.89	1	43.8	6.57	0.75	0.91	1	41.4	7.71	0.78	0.94	1	38.4	8.98	0.8	0.98	1
	2595	47.5	5.52	0.79	0.97	1	45.7	6.52	0.8	0.99	1	43.3	7.66	0.82	1	1	40.7	8.92	0.86	1	1
	3070	49.1	5.49	0.84	1	1	47.7	6.47	0.85	1	1	45.5	7.6	0.88	1	1	42.8	8.87	0.93	1	1
19.4°C	2125	48.6	5.5	0.58	0.72	0.85	46.8	6.49	0.58	0.72	0.87	44.4	7.62	0.6	0.75	0.9	41.4	8.9	0.61	0.77	0.94
	2595	50.3	5.47	0.61	0.77	0.93	48.6	6.45	0.62	0.78	0.95	46	7.58	0.62	0.8	0.98	43	8.86	0.66	0.83	1
	3070	51.6	5.45	0.64	0.82	0.99	50	6.42	0.65	0.83	1	47.4	7.55	0.66	0.85	1	44.3	8.83	0.68	0.89	1
21.7°C	2125	51.2	5.45	0.43	0.57	0.69	49.6	6.43	0.44	0.57	0.7	47.2	7.55	0.44	0.58	0.72	44.4	8.83	0.44	0.6	0.74
	2595	53.1	5.42	0.44	0.6	0.75	51.7	6.39	0.44	0.61	0.76	49.2	7.51	0.45	0.61	0.77	46.1	8.79	0.46	0.64	0.8
	3070	54.3	5.41	0.45	0.62	0.79	53	6.37	0.45	0.64	0.81	50.5	7.48	0.47	0.65	0.83	47.3	8.76	0.47	0.66	0.86

(2) ELS120S4S + ELA240S4D (2ND STAGE)

Entering Wet Bulb Temperature	Total Air Volume	Outdoor Air Temperature Entering Outdoor Coil																			
		26.7°C					35°C					43.3°C					46°C				
		Total Cool Cap.	Comp. Motor Input	Sensible To Total Ratio (S/T)			Total Cool Cap.	Comp. Motor Input	Sensible To Total Ratio (S/T)			Total Cool Cap.	Comp. Motor Input	Sensible To Total Ratio (S/T)			Total Cool Cap.	Comp. Motor Input	Sensible To Total Ratio (S/T)		
				Dry Bulb					Dry Bulb					Dry Bulb					Dry Bulb		
		L/s	kW	kW	24°C	27°C	29°C	kW	kW	24°C	27°C	29°C	kW	kW	24°C	27°C	29°C	kW	kW	24°C	27°C
17.2°C	3020	61.9	11.46	0.75	0.91	1	57.9	13.38	0.78	0.94	1	52.8	15.72	0.82	0.99	1	51.2	16.56	0.83	1.00	1.00
	3775	64.6	11.59	0.81	0.99	1	60.6	13.53	0.84	1	1	55.8	15.89	0.89	1	1	54.3	16.72	0.90	1.00	1.00
	4530	67.2	11.71	0.87	1	1	63.5	13.68	0.9	1	1	58.6	16.03	0.95	1	1	56.8	16.88	0.97	1.00	1.00
19.4°C	3020	65.8	11.64	0.59	0.73	0.87	61.8	13.59	0.61	0.75	0.9	56.3	15.91	0.63	0.79	0.95	54.6	16.74	0.64	0.81	0.97
	3775	68.5	11.77	0.62	0.79	0.95	64.2	13.71	0.64	0.82	0.99	58.4	16.02	0.66	0.86	1	56.3	16.83	0.68	0.88	1.00
	4530	70.6	11.87	0.66	0.85	1	65.8	13.81	0.68	0.88	1	60	16.12	0.71	0.93	1	57.9	16.94	0.73	0.95	1.00
21.7°C	3020	69.6	11.83	0.44	0.58	0.7	65.5	13.78	0.45	0.59	0.73	59.9	16.11	0.46	0.61	0.76	58.0	16.95	0.46	0.63	0.78
	3775	72.5	11.97	0.45	0.61	0.77	68	13.93	0.46	0.63	0.79	62.3	16.25	0.46	0.66	0.83	60.1	17.06	0.48	0.67	0.86
	4530	74.8	12.08	0.46	0.65	0.83	69.9	14.03	0.46	0.66	0.85	63.8	16.35	0.48	0.7	0.9	61.6	17.19	0.49	0.72	0.92

Entering Wet Bulb Temperature	Total Air Volume	Outdoor Air Temperature Entering Outdoor Coil																	
		48°C					50°C					51.7°C							
		Total Cool Cap.	Comp. Motor Input	Sensible To Total Ratio (S/T)			Total Cool Cap.	Comp. Motor Input	Sensible To Total Ratio (S/T)			Total Cool Cap.	Comp. Motor Input	Sensible To Total Ratio (S/T)					
				Dry Bulb					Dry Bulb					Dry Bulb					
		L/s	kW	kW	24°C	27°C	29°C	kW	kW	24°C	27°C	29°C	kW	kW	24°C	27°C	29°C		
17.2°C	3020	49.8	17.21	0.85	1.00	1.00	48.6	17.94	0.86	1.00	1.00	47.6	18.55	0.86	1	1			
	3775	53.1	17.42	0.91	1.00	1.00	51.7	18.11	0.93	1.00	1.00	50.6	18.76	0.95	1	1			
	4530	55.5	17.53	0.98	1.00	1.00	54.2	18.26	0.99	1.00	1.00	52.8	18.86	1	1	1			
19.4°C	3020	53.1	17.42	0.65	0.82	0.98	51.6	18.11	0.65	0.83	0.99	50.3	18.71	0.65	0.84	1			
	3775	54.9	17.50	0.69	0.89	1.00	53.4	18.22	0.70	0.91	1.00	52	18.85	0.7	0.92	1			
	4530	56.2	17.59	0.73	0.96	1.00	54.6	18.29	0.74	0.98	1.00	53.2	18.91	0.75	0.99	1			
21.7°C	3020	56.5	17.62	0.47	0.64	0.79	55.0	18.30	0.46	0.64	0.80	53.6	18.94	0.47	0.64	0.81			
	3775	58.4	17.71	0.47	0.68	0.87	56.9	18.42	0.48	0.68	0.88	55.5	19.08	0.48	0.69	0.89			
	4530	60.0	17.84	0.49	0.73	0.94	58.2	18.50	0.50	0.73	0.96	56.7	19.13	0.51	0.74	0.97			

REVISIONS

Sections	Description of Change
Options/Accessories	Added Furnace Twinning Kit.



Visit us at www.Lennox.com

For the latest technical information, www.LennoxCommercial.com

Contact us at 1-800-4-LENNOX

NOTE - Due to Lennox' ongoing commitment to quality, Specifications, Ratings and Dimensions subject to change without notice and without incurring liability. Improper installation, adjustment, alteration, service or maintenance can cause property damage or personal injury. Installation and service must be performed by a qualified installer and servicing agency.

©2021 Lennox Industries, Inc.