



**COMMERCIAL
PRODUCT SPECIFICATIONS**



LANDMARK®
Performance Marked by Flexibility™



45.7 to 88 kW (13 to 25 Tons)
Net Cooling Capacity - 37.1 to 68.6 kW (127 000 to 234 000 Btuh)
Optional Electric Heat - 11.5 to 45.9 kW

MODEL NUMBER IDENTIFICATION

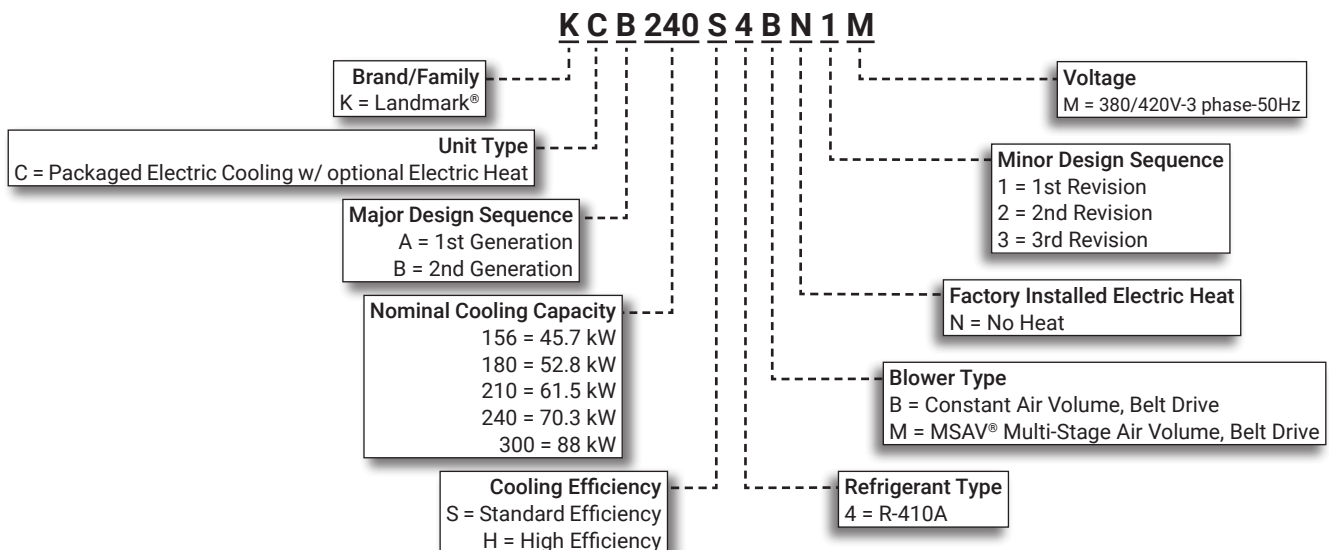

FEATURE HIGHLIGHTS

Landmark® rooftop units from Lennox are the new standard for reliable, efficient rooftop units built for long-lasting performance that can significantly improve indoor and outdoor environments.

1. Scroll Compressors
2. Filter/Driers
3. Environ™ Coil System
4. Outdoor Coil Fan Motors
5. Heavy-Gauge Steel Cabinet
6. Constant or MSAV® Multi-Stage Air Volume Blower
7. Unit Control
8. Electric Heat (option)
9. Air Filters
10. Economizer (option)
11. Downflow Barometric Relief Dampers With Exhaust Hood (option)
12. Power Exhaust Fan (option)

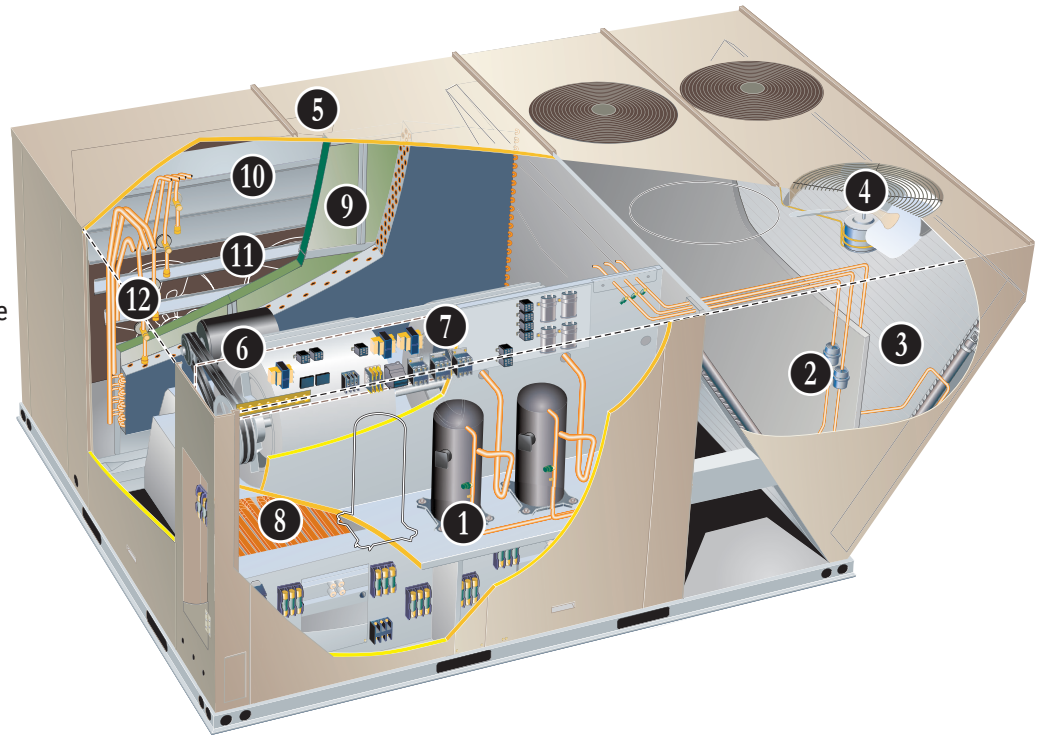

CONTENTS

Approvals	3
Blower Data	30
Dimensions - Accessories	41
Dimensions - Unit	38
Electrical/Electric Heat Data - High Efficiency	35
Electrical/Electric Heat Data - Standard Efficiency	34
Electric Heat Capacities	36
Features And Benefits	3
Model Number Identification.	1
Optional Conventional Temperature Control Systems	10
Options / Accessories - Standard And High Efficiency Models.	11
Outdoor Sound Data	36
Ratings - High Efficiency	26
Ratings - Standard Efficiency	18
Specifications - High Efficiency	17
Specifications - Standard Efficiency.	15
Unit Clearances	36
Weight Data	37

APPROVALS

PERFORMANCE/QUALITY

- Components bonded for grounding to meet safety standards for servicing required by Underwriters Laboratories (UL) and the International Electrotechnical Commission (IEC).
- Cooling performance is rated at test conditions included in Air-Conditioning, Heating and Refrigeration (AHRI) Standard 340/360 while operating at rated voltage and air volumes.
- International Organization for Standardization (ISO) 9001 Registered Manufacturing Quality System

FEATURES AND BENEFITS

COOLING SYSTEM

- Designed to maximize sensible and latent cooling performance at design conditions
- System can operate from -1°C to 52°C without any additional controls

R-410A Refrigerant

- Non-chlorine
- Ozone friendly

1 Scroll Compressors

- Scroll compressors on all models for high performance, reliability and quiet operation
- Resiliently mounted on rubber grommets for quiet operation

Compressor Crankcase Heaters

- Protect against refrigerant migration that can occur during low ambient operation

Thermal Expansion Valves (All High Efficiency Models, 300S Model)

- Assures optimal performance throughout the application range
- Removable element head

Refrigerant Metering Orifice (All Standard Efficiency Models except 300S Model)

- Accurately meters refrigerant in system
- Refrigerant control is accomplished by exact sizing of refrigerant metering orifice

2 Filter/Driers

- High capacity filter/drier protects the system from dirt and moisture

High Pressure Switches

- Protects the compressor from overload conditions such as dirty condenser coils, blocked refrigerant flow, or loss of outdoor fan operation

Freezestats

- Protects the evaporator coil from damaging ice build-up due to conditions such as low/no airflow, or low refrigerant charge

3 Environ™ Coil System

Lightweight, all aluminum brazed fin construction

- Constructed of three components
 - A flat extrusion tube
 - Fins in-between the flat extrusion tube
 - Two refrigerant manifolds



Environ™ Coil System Features:

- Improved heat transfer performance due to high primary surface area (flat tubes) versus secondary surface (fins)
- Smaller internal volume (reduced refrigerant charge)
- High durability
- All aluminum construction
- Fewer brazed joints
- Compact design
- Reduced unit weight
- Easy maintenance/cleaning
- Face split design
- Mounting brackets with rubber inserts
- Angled cabinet design protects coil from damage

Evaporator Coil

- Copper tube construction
- Enhanced rippled-edge aluminum fins
- Flared shoulder tubing connections
- Silver soldered construction
- Factory leak tested
- Cross-row circuiting with rifled tubing

Condensate Drain Pan

- Plastic, sloped drain pan
- Side or bottom drain connections

FEATURES AND BENEFITS

COOLING SYSTEM (continued)

- 4 Outdoor Coil Fan Motors**
- Thermal overload protected
 - Totally enclosed
 - Permanently lubricated ball bearings
 - Shaft up
 - Wire basket mount

Outdoor Coil Fans

- Polyvinyl chloride (PVC) coated fan guard furnished.

Required Selections

Cooling Capacity

- Specify nominal cooling capacity

Options/Accessories

Factory Installed

Conventional Fin/Tube Condenser Coil (replaces Environ™ Coil System, Standard Efficiency Models only)

- Copper tube construction
- Enhanced rippled-edge aluminum fins
- Flared shoulder tubing connections
- Silver soldered construction

Field Installed

Condensate Drain Trap

- Available in copper or polyvinyl chloride (PVC)

Drain Pan Overflow Switch

- Monitors condensate level in drain pan, shuts down unit if drain becomes clogged

Low Ambient Controls

- Units operate satisfactorily down to 7°C outdoor air temperature without any additional controls
- Two low ambient control options are available for field installation
 1. **Low Ambient Control Kit (-1°C)** - Allows unit operation down to -1°C
 2. **Low Ambient Control Kit (-17°C)** - Allows unit operation down to -17°C without evaporator coil icing
 - Head pressure speed control reduces outdoor fan operation during low ambient conditions until head pressure rises to the setpoint
 - Pressure transducers are mounted on the liquid lines
 - High pressure switches are furnished to replace existing
 - Wiring harnesses are furnished for simple plug-in wiring to fans and controller

CABINET

5 Construction

- Heavy-gauge steel panels
- Full perimeter heavy-gauge galvanized steel base rail
- Base rails have rigging holes
- Three sides of the base rail have forklift slots
- Raised edges around duct and power entry openings in the bottom of the unit for water protection

Airflow Choice

- Units are shipped in downflow (vertical) return air flow configuration

NOTE - Units can be field converted to horizontal air flow with optional Horizontal Return Air Panel Kit and Horizontal Roof Curb.

Power Entry

- Electrical lines can be brought through the unit base or through horizontal access knock-outs

Exterior Panels

- Constructed of heavy-gauge, galvanized steel
- Two-layer enamel paint finish

Insulation

- Fully insulated with non-hygroscopic fiberglass insulation (conditioned areas)
- Unit base is fully insulated
- Base insulation serves as an air seal to the roof curb, eliminating the need to add a seal during installation

Access Panels

- Economizer/Filter section
- Heating/Blower section
- Compressor/Controls section

Options/Accessories

Factory Installed

Corrosion Protection

- Completely flexible immersed coating
- Electrodeposited dry film process
- AST ElectroFin E-Coat
- Meets Mil Spec MIL-P-53084, ASTM B117 Standard Method Salt Spray Testing.
- Indoor Corrosion Protection:
 - Coated coil
 - Painted blower housing
 - Painted indoor base
- Outdoor Corrosion Protection:
 - Coated coil
 - Painted outdoor base

FEATURES AND BENEFITS

CABINET (continued)

Options/Accessories (continued)

Hinged Access Panels

- Filter section
- Heating/Blower section
- Compressor/Controls section
- Panels seal and slotted, 29 mm hex bolt quarter-turn latches provide a tight air and water seal

Field Installed

Combination Coil/Hail Guards

- Heavy gauge steel frame painted to match cabinet with expanded metal mesh to protect the outdoor coil from damage.

Horizontal Return Air Panel Kit

- Required for horizontal applications with Horizontal Roof Curb, contains panel with return air opening for field replacement of existing unit panel and panel to cover bottom return air opening in unit, see dimension drawings.

BLOWER

- 6** A wide selection of supply air blower options are available to meet a variety of airflow requirements.

Motor

- Overload protected, equipped with ball bearings. Belt drive motors are offered on all models and are available in several different sizes to maximize air performance.

Supply Air Blower

- Forward curved blades, double inlet, blower wheel is statically and dynamically balanced. Equipped with ball bearings and adjustable pulley (allows speed change).
- Blower assembly slides out of unit for servicing.

Required Selections

- Order blower motor output and drive kit number required when base unit is ordered, see Drive Kit Specifications Table.

Select Constant Air Volume (CAV) or MSAV® Multi-Stage Air Volume Blower Option

- Constant Air Volume (CAV) models supply a constant volume of air
- MSAV® Multi-Stage Air Volume models utilize a Variable Frequency Drive (VFD) to stage the supply air blower airflow
 - The VFD alters the frequency and voltage of the power supply to the blower to control blower speed
 - The supply air blower has two speeds:

1. Low speed for part-load cooling operation

NOTE - Low speed is 66% of high speed

2. High speed for full load cooling and all heat modes

- Full speed blower operation is set by adjusting the motor pulley to deliver the desired air volume
- The ventilation speed is selectable between high and low speed

NOTE - Part load airflow in cooling mode on MSAV® Multi-Stage Air Volume models should not be set below 30 L/s per kW to reduce the risk of evaporator coil freeze-up.

- The VFD has an operational range of -40 to 52°C outdoor air ambient temperature
- Lower operating costs are obtained when the blower is operated on lower speeds

MSAV® Multi-Stage Air Volume Sequence of Operation

- Ventilation speed is determined by the VENT SPEED switch setting on VFD control board (LO or HI)
- Blower operates in low speed for mechanical cooling (Y1)
- Blower operates in high speed for any other mode (free cooling, mechanical cooling Y1+Y2, and heating)
- Economizer damper minimum position is fully closed in unoccupied mode
- In occupied mode, the economizer damper minimum position is determined by the setting of the two potentiometers on VFD control board:
 - **LO SPD MIN POS** potentiometer sets the minimum position when blower is operating at low speed
 - **HI SPD MIN POS** potentiometer sets the minimum position when blower is operating at high speed

Ordering Information

- Specify standard or high efficiency blower motor, motor horsepower and drive kit number when base unit is ordered

CONTROLS

7 Unit Control

- All control voltage is provided via a 24V (secondary) transformer with built-in circuit breaker protection
- Up to 2 heat / 2 cool staging with a third party DDC control system or thermostat
- Low voltage terminal block provides screw terminal connections for thermostat or controller wiring
- Night Setback Mode saves energy by closing outdoor air dampers and operating supply fan on thermostat demand only

Options/Accessories

Field Installed

Smoke Detector

- Photoelectric type
- Installed in supply air section, return air section or both sections
- Available with power board and single sensor (supply or return) or power board and two sensors (supply and return)
- Power board located in unit control compartment.

Thermostats

- Control system and thermostat options, see page 10

FEATURES AND BENEFITS

ELECTRICAL

All units include terminal block and fuse block in power entry junction box for single power entry application.

Marked & Color-Coded Wiring

- All electrical wiring is color-coded and marked to identify which components it is connecting

Electrical Plugs

- Positive connection electrical plugs are used to connect common accessories or maintenance parts for easy removal or installation

Options/Accessories

Field Installed

8 Electric Heat

- Helix wound nichrome elements
- Individual element limit controls
- Wiring harness
- Unit fuse block
- See Options / Accessories tables for ordering information

Phase Monitor

- Phase monitor detects the phasing of incoming power
- If the incoming power is out of phase or if any of the three phases are lost red LED on the phase monitor will light and the unit will not start
- Green LED indicates normal operation with correct incoming power phasing

NOTE - Phase Monitor is factory Installed in the control compartment on all units equipped with the MSAV® Multi-Stage Air Volume option.

Required Selections

Voltage Choice

- Specify when ordering base unit

INDOOR AIR QUALITY

9 Air Filters

- Disposable 51 mm filters furnished as standard

Options/Accessories

Field Installed

Healthy Climate® High Efficiency Air Filters

- Disposable MERV 8 or MERV 13 (Minimum Efficiency Reporting Value based on ASHRAE 52.2) efficiency
- 51 mm pleated filters

Healthy Climate® UVC Germicidal Lamps

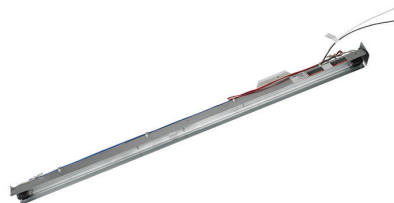

- Germicidal lamps emit ultra-violet (UV-C) energy, which has been proven to be effective in reducing microbes such as viruses, bacteria, yeasts, and molds
- This process either destroys the organism or controls its ability to reproduce
- UV-C energy greatly reduces the growth and proliferation of mold and other bioaerosols (bacteria and viruses) on illuminated surfaces (particularly coil and drain pan)
- Field installed in the blower/evaporator coil section
- Magnetic safety interlock terminates power when access panels are removed
- All necessary hardware for installation is included
- Lamps operate on 220V-1ph power supply

NOTE - Step-down transformer must be field supplied for field installation for 380/420V primary to 220V secondary.

Indoor Air Quality (CO₂) Sensors

- Monitors CO₂ levels
- Reports to the Unit Controller which adjusts economizer dampers as needed

OPTIONS / ACCESSORIES

ECONOMIZER

Factory or Field Installed

- 10** Economizer
(Standard and High Performance Common Features)
- Outdoor Air Hood with mist elimination filter furnished
 - Mixed Air Sensor furnished for field installation in the rooftop unit

NOTE - Sensor is factory installed when Economizer is factory installed.

Standard Economizer Features

- Gear-driven action
- 24-volt, fully-modulating spring return motor
- Return air and outdoor air dampers
- Plug-in connections to unit
- Nylon bearings
- Neoprene seals

Standard Economizer Control Module

- Standard Economizer Control Module operation is based on outdoor air temperatures

Economizer Controls:

- **Damper Minimum Position** - Can be set lower than traditional minimum air requirements resulting in cost savings
- **IAQ Sensor** - Signals dampers to modulate and maintain 55°F when CO₂ is higher than the CO₂ setpoint
- **Demand Control Ventilation (DCV) LED** - A steady green Demand Control Ventilation LED indicates the IAQ reading is higher than setpoint and requires more fresh air
- **Free Cool LED** - A steady green LED indicates outdoor air is suitable for free cooling
 - Free Cooling runs when outdoor air temperature is lower than the set temperature on the economizer control

NOTE: The Free Cooling default setting for outdoor air temperature sensor is 55°F.



High Performance Economizer Features

- Gear-driven action
- High torque 24-volt fully-modulating spring return damper motor
- Return air and outdoor air dampers
- Plug-in connections to unit
- Stainless steel bearings
- Enhanced thermoplastic vulcanizate (TPV) seals
- Flexible stainless steel jamb seals

High Performance Economizer Control Module

- Provides inputs and outputs to control economizer based on parameter settings
- Free cooling based on single dry bulb temperature, or combination temperature + humidity sensors
- Automatic switchover for different control modes
- Parameter settings based on climate zone, using GPS functionality in the Climatix Mobile application
- LED indication for free cooling operation, sensor operation and damper operation
- Quick installation and easy commissioning with the **Climatix Mobile App** on a mobile device

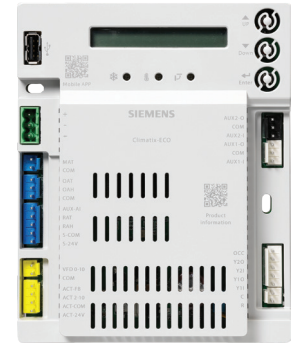

NOTE - WLAN Stick is required for App connection to module(s).

- Module displays any alarm messages (fault detection and diagnostics) as an aid in troubleshooting
- RS485 port for BACnet MSTP or Modbus RTU communication
- USB port for firmware updates and WLAN connection for setup and commissioning
- QR codes on module for quick access to download Climatix Mobile App and user documentation
- User Interface for normal operation, parameter setup, and alarm notifications with an LCD display and three operation buttons:
 1. **Up Button** - Move to the previous value, step or category
 2. **Down Button** - Move to the next value, step or category
 3. **Enter Button** -
 - Press to edit the current value or option
 - Press to confirm a newly selected value or option
 - Press Enter + Up to jump up one category
 - Press Enter + Down to jump down one category

NOTE - Refer to Installation Instructions for complete setup information and menu parameters available.

OPTIONS / ACCESSORIES

ECONOMIZER (continued)

Factory or Field Installed

Single Enthalpy Temperature Control

- Outdoor air enthalpy sensor enables economizer if the outdoor enthalpy is less than the setpoint of the control

Field Installed

Differential Enthalpy Control

- Order two Single Enthalpy Controls:
 - One is field installed in the return air section
 - One in the outdoor air section
- Allows the economizer control board to select between outdoor air or return air, whichever has lower enthalpy

WLAN Stick

- Required for Climatix Mobile App usage
- Plugs into USB port on Module to provide a temporary WLAN connection for setup, commissioning, and servicing

NOTE - Only one WLAN Stick is required and can be used on multiple modules.

EXHAUST

Factory or Field Installed

11 Downflow Barometric Relief Dampers With Exhaust Hood

- Allow relief of excess air
- Aluminum blade dampers prevent blow back and outdoor air infiltration during off cycle
- Exhaust hood with bird screen is furnished

Field Installed

Horizontal Barometric Relief Dampers With Exhaust Hood

- For use when unit is configured for horizontal applications requiring an economizer
- Allows relief of excess air
- Aluminum blade dampers prevent blow back and outdoor air infiltration during off cycle
- Field installed in return air duct
- Exhaust hood with bird screen is furnished

12 Power Exhaust Fan

- Installs internal to unit for downflow applications only with economizer option
- Provides exhaust air pressure relief
- Interlocked to run when supply air blower is operating, fan runs when outdoor air dampers are 50% open (adjustable)
- Motor is overload protected
- Requires Economizer with Outdoor Air Hood and Downflow Barometric Relief Dampers.
- Dual fans
- 508 mm diameter
- 5 blades with
- Two 0.25 kW motors

OUTDOOR AIR

Factory or Field Installed

Outdoor Air Damper - Downflow or Horizontal With Air Hood

- Linked mechanical dampers
- 0 to 25% (fixed) outdoor air adjustable
- Installs in unit
- Includes outdoor air hood
- Motorized model features fully modulating spring return damper motor with plug-in connection
- Manual model features parallel blade, gear-driven dampers with adjustable fixed position

NOTE - Outdoor Air Hood is included when damper is factory installed and is furnished with damper when ordered for field installation.

OPTIONS / ACCESSORIES

ROOF CURBS

- Nailer strip furnished
- Mates to unit,
- US National Roofing Contractors Approved
- Shipped knocked down

Downflow

Hybrid Roof Curbs

- Interlocking tabs fasten corners together
- No tools required
- Can also be fastened together with furnished hardware.
- Available in 203, 356, 457, and 610 mm heights

Adjustable Pitch Curb

- Fully adjustable pitch curb provides a level platform for rooftop units allowing flexible installations on roofs with uneven or sloped angles
- Maximum slope is 19 mm per 300 mm in any direction
- Uses interlocking tabs to fasten corners together
- No tools required
- Hardware is furnished to connect upper curb with lower curb
- Available in 356 mm height

Adaptor Curbs (not shown)

- Curbs are regionally sourced
- Dimensions vary based upon the source

NOTE - Contact your local sales representative for a detailed cut sheet with applicable dimensions.

Horizontal

- Converts unit from downflow to horizontal (side) air flow
- Return air is on unit
- Supply air is on curb
- See dimension drawings
- Available in 660, 762, 940 and 1041 mm heights

NOTE - Requires Horizontal Return Air Panel Kit.

NOTE - Optional Insulation Kit is available to help prevent sweating.

CEILING DIFFUSERS

Ceiling Diffusers (Flush or Step-Down)

- Aluminum grilles; large center grille
- Insulated diffuser box with flanges
- Hanging rings (furnished)
- Interior transition (even air flow)
- Internally sealed (prevents recirculation)
- Adapts to T-bar ceiling grids or plaster ceilings

Transitions (Supply and Return)

- Used with diffusers
- Installs in roof curb
- Galvanized steel construction
- Flanges furnished for duct connection to diffusers
- Fully insulated

OPTIONAL CONVENTIONAL TEMPERATURE CONTROL SYSTEMS

ComfortSense® 7500 Commercial 7-Day Programmable Thermostat



- Four-Stage Heating / Two-Stage Cooling
- Universal Multi-Stage
- Intuitive Touchscreen Interface
- Automatic Changeover between Heating and Cooling
- Full Seven-Day Programming
- Four Time Periods Per Day
- Temperature and Humidity Control
- One-Touch Away Mode
- Holiday Scheduling
- Smooth Setback Recovery (SSR)
- Performance Reports
- Notifications/Reminders
- Dehumidification/Humiditrol® Control for Split Systems and Rooftop Units
- Economizer Relay Control
- Backlit Display
- Wallplate Furnished
- FDD, ASHRAE and IECC Compliant

ComfortSense® 3000 Commercial 5-2 Day Programmable Thermostat



- Two-Stage Heating / Two-Stage Cooling
- Conventional Systems
- Intuitive Interface
- 5-2 Day Programming
- Program Hold
- Remote Indoor Temperature Sensing
- Smooth Setback Recovery (SSR)
- Economizer Relay Control
- Maintenance/Filter/Service Reminders
- Backlit Display
- Wallplate Furnished
- Simple Up and Down Temperature Control

BACnet Compatible Thermostat With Reheat Function



- 7-Day Programmable
- For units with or without Humiditrol®
- BTL listed MS/TP ensures compatibility with any BACnet system
- Built-in control programs for conventional and heat pump applications
- Conventional systems up to 3-stage heat and 3-stage cool
- Heat pumps with 1 or 2 compressors and up to 2-stage auxiliary heat
- On-board temperature and humidity sensor
- Multiple configurable inputs and outputs enable advanced control strategies
- Set-up Wizard enables rapid system configuration
- No special tools required for installation or commissioning
- Seven-day (2, 4 or 6 event) occupancy scheduling per day
- Backlit 5-inch LCD touchscreen

Description	Model No.	Catalog No.
ComfortSense® 7500 7-Day Programmable	C0STAT06FF2L	17G74
Universal thermostat locking guard (clear)	C0MISC15AE1-	39P21
Temperature Sensors		
1 Remote non-adjustable wall-mount 20k	C0SNZN01AE2-	47W36
1 Remote non-adjustable wall-mount 10k	C0SNZN73AE1-	47W37
Remote non-adjustable discharge air (duct mount)	C0SNDC00AE1-	19L22
Outdoor temperature sensor	C0SNSR03AE1-	X2658
ComfortSense® 3000 5-2 Day Programmable	C0STAT05FF1L	11Y05
Thermostat wall mounting plate	C0MISC17AE1-	X2659
Temperature Sensor	Remote non-adjustable wall mount 10k averaging	47W37
2 7-Day Programmable - Bacnet Compatible	---	Y8241
BACnet Controls (no reheat)		
BACnet® Module (factory or field installed)	K0CTRL31C-2	16X72
BACnet® Room Sensor with Display (field)	K0SNSR01FF1	97W23
BACnet® Room Sensor without Display (field)	K0SNSR00FF1	97W24

¹ Remote wall-mount sensors can be applied in any of the following combinations:

- One Sensor - (1) 47W36
- Two Sensors - (2) 47W37
- Three Sensors - (2) 47W36 and (1) 47W37
- Four Sensors - (4) 47W36
- Five Sensors - (3) 47W36 and (2) 47W37

² BACnet Thermostat (Y8241) will control units with and without the Humiditrol® option. If there is a mix of units equipped with and without Humiditrol on the same site, this thermostat can be used for all units if desired.

OPTIONS / ACCESSORIES - STANDARD AND HIGH EFFICIENCY MODELS

Item Description	Catalog Number	Unit Model No.						
		KCA	KCA	KCA	KCA	---		
		---	KCB	KCB	KCB	KCB		
		156	180	210	240	300		
COOLING SYSTEM								
Condensate Drain Trap	Polyvinyl Chloride (PVC)	22H54	X	X	X	X	X	
	Copper	76W27	X	X	X	X	X	
Corrosion Protection	Factory		O	O	O	O	O	
Drain Pan Overflow Switch		10C24	X	X	X	X	X	
Efficiency	Standard or High	Factory	O	O	O	O	O	
Refrigerant Type		R-410A	O	O	O	O	O	
BLOWER - SUPPLY AIR								
Blower Option	CAV (Constant Air Volume)	Factory	O	O	O	O	O	
	MSAV® Multi-Stage Air Volume	Factory	O	O	O	O	O	
Motors - Constant Air Volume (CAV)	Belt Drive (standard efficiency) - 1.5 kW (2 hp)	Factory	O					
	Belt Drive (standard efficiency) - 2.2 kW (3 hp)	Factory	O	O	O			
	Belt Drive (standard efficiency) - 3.7 kW (5 hp)	Factory	O	O	O	O	O	
	Belt Drive (standard efficiency) - 5.6 kW (7.5 hp)	Factory		O	O	O	O	
	Belt Drive (standard efficiency) - 7.5 kW (10 hp)	Factory				O	O	
Motors - MSAV® (Multi-Stage Air Volume)	Belt Drive (standard efficiency) - 1.5 kW (2 hp)	Factory	O					
	Belt Drive (standard efficiency) - 2.2 kW (3 hp)	Factory	O	O	O			
	Belt Drive (standard efficiency) - 3.7 kW (5 hp)	Factory	O	O	O	O	O	
	Belt Drive (standard efficiency) - 5.6 kW (7.5 hp)	Factory		O	O	O	O	
	Belt Drive (standard efficiency) - 7.5 kW (10 hp)	Factory				O	O	
Drive Kits	CAV (rev/min)	MSAV (rev/min)						
See Blower Data Tables for usage and selection	Kit #1 446-604	Kit #1 535-725	Factory	O	O	O		
	Kit #2 592-804	Kit #2 710-965	Factory	O	O	O		
	Kit #3 571-721	Kit #3 685-865	Factory	O	O	O	O	O
	Kit #4 708-871	Kit #4 850-1045	Factory	O	O	O	O	O
	Kit #5 788-988	Kit #5 945-1185	Factory	O	O	O	O	O
	Kit #6 708-871	Kit #6 850-1045	Factory		O	O	O	O
	Kit #7 788-988	Kit #7 945-1185	Factory		O	O	O	O
	Kit #8 871-1071	Kit #8 1045-1285	Factory		O	O	O	O
	Kit #9 946-1138	Kit #9 1135-1365	Factory				O	O
	Kit #10 871-1071	Kit #10 1045-1285	Factory				O	O
	Kit #11 946-1138	Kit #11 1135-1365	Factory				O	O
CABINET								
Hinged Access Panels		Factory	O	O	O	O	O	
CONTROLS								
NOTE - Also see Conventional Thermostat Control Systems on page 10 for Additional Options.								
Smoke Detector - Supply or Return (Power board and one sensor)		22H56	X	X	X	X	X	
Smoke Detector - Supply and Return (Power board and two sensors)		22H57	X	X	X	X	X	
L Connection® Building Automation System		---	X	X	X	X	X	

NOTE - Catalog numbers shown are for ordering field installed accessories.

OX - Configure To Order (Factory Installed) or Field Installed

O = Configure To Order (Factory Installed)

X = Field Installed

OPTIONS / ACCESSORIES - STANDARD AND HIGH EFFICIENCY MODELS

Item Description	Catalog Number	Unit Model No.				
		KCA	KCA	KCA	KCA	---
		---	KCB	KCB	KCB	KCB
		156	180	210	240	300
ELECTRICAL						
Voltage 50 Hz	380/420V - 3 phase	Factory	O	O	O	O
^{1,2} Electric Heat						
11.5 kW	380/420V-3ph	67W96	X	X	X	X
23 kW	380/420V-3ph	67W98	X	X	X	X
34.5 kW	380/420V-3ph	68W00		X	X	X
45.9 kW	380/420V-3ph	68W02		X	X	X
INDOOR AIR QUALITY						
Air Filters						
Healthy Climate® High Efficiency Air Filters 610 x 610 x 51 (Order 6 per unit)	MERV 8	54W67	X	X	X	X
	MERV 13	52W40	X	X	X	X
Replacement Media Filter With Metal Mesh Frame (includes non-pleated filter media)		44N61	X	X	X	X
Indoor Air Quality (CO₂) Sensors						
Sensor - Wall-mount, off-white plastic cover with LCD display		77N39	X	X	X	X
Sensor - Wall-mount, off-white plastic cover, no display		87N53	X	X	X	X
Sensor - Black plastic case with LCD display, rated for plenum mounting		87N52	X	X	X	X
Sensor - Wall-mount, black plastic case, no display, rated for plenum mounting		87N54	X	X	X	X
CO ₂ Sensor Duct Mounting Kit - for downflow applications		85L43	X	X	X	X
Aspiration Box - for duct mounting non-plenum rated CO ₂ sensors (87N53 or 77N39)		90N43	X	X	X	X
UVC Germicidal Light Kit						
¹ Healthy Climate® UVC Light Kit (220V-1ph)		21A94	X	X	X	X
ECONOMIZER						
Standard Economizer With Outdoor Air Hood						
Standard Economizer Downflow or Horizontal Applications - Includes Outdoor Air Hood, order Downflow or Horizontal Barometric Relief Dampers separately		13U48	OX	OX	OX	OX
Standard Economizer Controls						
Single Enthalpy		21Z09	OX	OX	OX	OX
Differential Enthalpy	Order 2	21Z09	X	X	X	X
High Performance Economizer With Outdoor Air Hood						
High Performance Economizer Downflow or Horizontal Applications - Includes Outdoor Air Hood, order Downflow or Horizontal Barometric Relief Dampers separately		23G24	OX	OX	OX	OX
High Performance Economizer Controls						
Single Enthalpy Control		23G26	OX	OX	OX	OX
Differential Enthalpy Control (order 2)		23G26	X	X	X	X
Barometric Relief Dampers With Exhaust Hood						
Downflow Barometric Relief Dampers		54W78	OX	OX	OX	OX
Horizontal Barometric Relief Dampers		16K99	X	X	X	X

¹ Nominal kW at 420V-3ph-50Hz.

² NOTE - Factory installed electric heat is only available with high efficiency models.

³ Lamps operate on 220V single-phase power supply. Step-down transformer must be field supplied for field installation for 380/420V primary to 220V secondary. Alternately, a separate 220V power supply may be used to directly power the UVC ballast(s).

NOTE - Catalog numbers shown are for ordering field installed accessories.

OX - Configure To Order (Factory Installed) or Field Installed

O = Configure To Order (Factory Installed)

X = Field Installed

OPTIONS / ACCESSORIES - STANDARD AND HIGH EFFICIENCY MODELS

Item Description	Catalog Number	Unit Model No.				
		KCA	KCA	KCA	KCA	---
		---	KCB	KCB	KCB	KCB
		156	180	210	240	300
OUTDOOR AIR						
Outdoor Air Dampers With Outdoor Air Hood						
Motorized	22J27	OX	OX	OX	OX	OX
Manual	13U05	OX	OX	OX	OX	OX
¹ POWER EXHAUST (DOWNFLOW APPLICATIONS ONLY)						
Standard Static	380/420V 75W93	OX	OX	OX	OX	OX
ROOF CURBS						
Hybrid Roof Curbs, Downflow						
203 mm height	11F58	X	X	X	X	X
356 mm height	11F59	X	X	X	X	X
457 mm height	11F60	X	X	X	X	X
610 mm height	11F61	X	X	X	X	X
Adjustable Pitched Curb						
356 mm height	43W26	X	X	X	X	X
Standard Roof Curbs, Horizontal - Requires Horizontal Return Air Panel Kit						
660 mm height - slab applications	11T89	X	X	X	X	
940 mm height - rooftop applications	11T96	X	X	X	X	
762 mm height - slab applications	11T90					X
1041 mm height - rooftop applications	11T97					X
Insulation Kit For Standard Horizontal Curbs						
for 660 mm height horizontal curb	73K32	X	X	X	X	
for 940 mm height horizontal curb	73K34	X	X	X	X	
for 762 mm height horizontal curb	73K33					X
for 1041 mm height horizontal curb	73K35					X
Horizontal Return Air Panel Kit						
Required for Horizontal Applications with Roof Curb	87M00	X	X	X	X	X
CEILING DIFFUSERS						
Step-Down - Order one	RTD11-185S	13K63	X	X		
	RTD11-275S	13K64			X	X
Flush - Order one	FD11-185S	13K58	X	X		
	FD11-275S	13K59			X	X
Transitions (Supply and Return) - Order one		12X68	X	X		
		12X70			X	X

¹ Field installed Power Exhaust requires Economizer with Outdoor Air Hood and Barometric Relief Dampers with Exhaust Hood. Must be order separately.

NOTE - Catalog numbers shown are for ordering field installed accessories.

OX - Configure To Order (Factory Installed) or Field Installed

O = Configure To Order (Factory Installed)

X = Field Installed

OPTIONS / ACCESSORIES - STANDARD EFFICIENCY MODELS ONLY

Item Description	Catalog Number	Unit Model No.			
		KCB 180S	KCB 210S	KCB 240S	KCB 300S
COOLING SYSTEM					
Conventional Fin/Tube Condenser Coil (replaces Environ™ Coil System)	Factory	O	O	O	O
Low Ambient Kits	-1°C	10T63	X	X	
		10T64			X
		10T65			X
	-17°C	18B95	X	X	
		18B96			X
		18B98			X
CABINET					
Combination Coil/Hail Guards	Environ™ Coil System	15T92	X	X	
		15T93			X
	Conventional Fin/Tube Condenser Coil	13T08	X	X	
		13T12			X

OPTIONS / ACCESSORIES - HIGH EFFICIENCY MODELS ONLY

Item Description	Catalog Number	Unit Model No.			
		KCA 156H	KCA 180H	KCA 210H	KCA 240H
COOLING SYSTEM					
Low Ambient Kits	-1°C	10T63	X		
		10T64		X	X
		10T65			X
	-17°C	18B95	X	X	
		18B96			X
		18B98			X
CABINET					
Combination Coil/Hail Guards	Environ™ Coil System	15T92	X		
		15T93		X	X
	Conventional Fin/Tube Condenser Coil	13T08	X		
		13T12		X	X

SPECIFICATIONS - STANDARD EFFICIENCY

General Data		Nominal kW (Tons)	52.8 (15)	52.8 (15)	61.5 (17.5)	61.5 (17.5)
		Model Number	KCB180S4B	KCB180S4M	KCB210S4B	KCB210S4M
		Efficiency Type	Standard	Standard	Standard	Standard
		Blower Type	CAV (Constant Air Volume)	MSAV® (Multi-Stage Air Volume)	CAV (Constant Air Volume)	MSAV® (Multi-Stage Air Volume)
Cooling Performance	Gross Cooling Capacity - kW (Btuh)		46.3 (158 000)	46.3 (158 000)	51.9 (177 000)	51.9 (177 000)
	¹ Net Cooling Capacity - kW (Btuh)		44.5 (152 000)	44.5 (152 000)	58.0 (198 000)	58.0 (198 000)
	AHRI Rated Air Flow - L/s (cfm)		2832 (6000)	2832 (6000)	2690 (5700)	2690 (5700)
	Total Unit Power - kW		16.0	16.0	18.2	18.2
	¹ EER (Btuh/Watt) at 35°C (95°F)		11.0	11.0	11.0	11.0
	² EER (Btuh/Watt) at 46°C (115°F)		7.8	7.8	7.8	7.8
	¹ IEER (Btuh/Watt)		12.4	13.8	12.4	13.5
Refrigerant Charge	Refrigerant Type		R-410A	R-410A	R-410A	R-410A
	Environ™ Coil System	Circuit 1	2.66 kg (5 lbs. 14 oz.)	2.66 kg (5 lbs. 14 oz.)	2.95 kg (6 lbs. 8 oz.)	2.95 kg (6 lbs. 8 oz.)
		Circuit 2	2.58 kg (5 lbs. 11 oz.)	2.58 kg (5 lbs. 11 oz.)	2.83 kg (6 lbs. 4 oz.)	2.83 kg (6 lbs. 4 oz.)
		Circuit 3	2.64 kg (5 lbs. 13 oz.)	2.64 kg (5 lbs. 13 oz.)	2.78 kg (6 lbs. 2 oz.)	2.78 kg (6 lbs. 2 oz.)
	Conventional Fin/Tube Coil Option	Circuit 1	5.64 kg (12 lbs. 7 oz.)	5.64 kg (12 lbs. 7 oz.)	4.99 kg (11 lbs. 0 oz.)	4.99 kg (11 lbs. 0 oz.)
		Circuit 2	5.44 kg (12 lbs. 0 oz.)	5.44 kg (12 lbs. 0 oz.)	4.99 kg (11 lbs. 0 oz.)	4.99 kg (11 lbs. 0 oz.)
		Circuit 3	5.07 kg (11 lbs. 3 oz.)	5.07 kg (11 lbs. 3 oz.)	4.99 kg (11 lbs. 0 oz.)	4.99 kg (11 lbs. 0 oz.)
Electric Heat Available, see page 13			11.5, 23, 34.5, 45.9 kW			
Compressor Type (number)			Scroll (3)			
Outdoor Coils	Net face area (total) - m ² (sq. ft.)		3.85 (41.4)	3.85 (41.4)	3.85 (41.4)	3.85 (41.4)
	Number of rows		1 (2)	1 (2)	1 (2)	1 (2)
	Environ™ (Fin/Tube) Fins per m (Fins per inch)		906 (23) / 787(20)	906 (23) / 787(20)	906 (23) / 787(20)	906 (23) / 787(20)
Outdoor Coil Fans	Motor - (No.) W (HP)		(3) 250 (1/3)	(3) 250 (1/3)	(3) 250 (1/3)	(3) 250 (1/3)
	Motor rev/min		896	896	896	896
	Total Motor watts		840	840	840	840
	Diameter - (No.) mm (in.)		(3) 610 (24)	(3) 610 (24)	(3) 610 (24)	(3) 610 (24)
	Number of blades		3	3	3	3
	Total Air volume - L/s (cfm)		4720 (10 000)	4720 (10 000)	4720 (10 000)	4720 (10 000)
Indoor Coils	Net face area (total) - m ² (sq. ft.)		1.99 (21.4)	1.99 (21.4)	1.99 (21.4)	1.99 (21.4)
	Tube diameter - mm (in.)		9.5 (3/8)	9.5 (3/8)	9.5 (3/8)	9.5 (3/8)
	Number of rows		3	3	4	4
	Fins per m (Fins per inch)		551 (14)	551 (14)	551 (14)	551 (14)
	Drain connection - No. and size		(1) 1 in. FPT	(1) 1 in. FPT	(1) 1 in. FPT	(1) 1 in. FPT
	Expansion device type		Refrigerant Metering Orifice (RFC)			
³ Indoor Blower and Drive Selection	Nominal Motor kW (HP)		2.2 (3)	2.2 (3)	2.2 (3)	2.2 (3)
	Maximum usable motor kW (HP)		2.6 (3.45)	2.6 (3.45)	2.6 (3.45)	2.6 (3.45)
	Kit # (rev/min range)	#3 (571-721)		#3 (685-865)	#3 (571-721)	#3 (685-865)
		#4 (708-871)		#4 (850-1045)	#4 (708-871)	#4 (850-1045)
		#5 (788-988)		#5 (945-1185)	#5 (788-988)	#5 (945-1185)
	Nominal Motor kW (HP)		3.7 (5)	3.7 (5)	3.7 (5)	3.7 (5)
	Maximum usable motor kW (HP)		4.3 (5.75)	4.3 (5.75)	4.3 (5.75)	4.3 (5.75)
	Kit # (rev/min range)	#3 (571-721)		#3 (685-865)	#3 (571-721)	#3 (685-865)
		#4 (708-871)		#4 (850-1045)	#4 (708-871)	#4 (850-1045)
		#5 (788-988)		#5 (945-1185)	#5 (788-988)	#5 (945-1185)
	Nominal Motor kW (HP)		5.6 (7.5)	5.6 (7.5)	5.6 (7.5)	5.6 (7.5)
	Maximum usable motor kW (HP)		6.4 (8.6)	6.4 (8.6)	6.4 (8.6)	6.4 (8.6)
Kit # (rev/min range)	#6 (708-871)		#6 (850-1045)	#6 (708-871)	#6 (850-1045)	
	#7 (788-988)		#7 (945-1185)	#7 (788-988)	#7 (945-1185)	
	#8 (871-1071)		#8 (1045-1285)	#8 (871-1071)	#8 (1045-1285)	
Blower wheel nominal diameter x width - mm (in.)		(2) 381 x 381 (15 x 15)				
Filters	Type of filter	Fiberglass, disposable				
	Number and size - mm (in.)	(6) 610 x 610 x 51 (24 x 24 x 2)				
Electrical characteristics			380/420V - 50 hertz - 3 phase			

NOTE - Net capacity includes evaporator blower motor heat deduction. Gross capacity does not include evaporator blower motor heat deduction.

¹ Rating test conditions are those included in Air Conditioning, Heating and Refrigeration Institute (AHRI) Standard 340/360; 35°C (95°F) outdoor air temperature and 27°C (80°F) db/19°C (67°F) wb entering evaporator air; minimum external duct static pressure while operating at rated voltage and air volumes.

² Rated at 46°C (115°F) outdoor air temperature and 27°C db/19°C (67°F) wb entering evaporator air (T3 Conditions).

³ Using total air volume and system static pressure requirements determine from blower performance tables from blower performance tables rev/min and motor output required. Maximum usable output of motors furnished are shown. If motors of comparable output are used, be sure to keep within the service factor limitations outlined on the motor nameplate

NOTE - Units equipped with MSAV® (Multi-Stage Air Volume) option are limited to a motor service factor of 1.0.

SPECIFICATIONS - STANDARD EFFICIENCY

General Data		Nominal kW (Tons)	70.3 (20)	70.3 (20)	88 (25)	88 (25)	
		Model Number	KCB240S4B	KCB240S4M	KCB300S4B	KCB300S4M	
		Efficiency Type	Standard	Standard	Standard	Standard	
		Blower Type	CAV (Constant Air Volume)	MSAV® (Multi-Stage Air Volume)	CAV (Constant Air Volume)	MSAV® (Multi-Stage Air Volume)	
Cooling Performance	Gross Cooling Capacity - kW (Btuh)		60.4 (206 000)	60.4 (206 000)	71.8 (245 000)	71.8 (245 000)	
	¹ Net Cooling Capacity - kW (Btuh)		58.0 (198 000)	58.0 (198 000)	68.6 (234 000)	68.6 (234 000)	
	AHRI Rated Air Flow - L/s (cfm)		2832 (6000)	2832 (6000)	3964 (8400)	3964 (8400)	
	Total Unit Power - kW		18.0	18.0	21.9	21.9	
	¹ EER (Btuh/Watt) at 35°C (95°F)		11.0	11.0	10.7	10.7	
	² EER (Btuh/Watt) at 46°C (115°F)		7.7	7.7	7.7	7.7	
	¹ IEER (Btuh/Watt)		12.4	13.6	11.2	13.8	
Refrigerant Charge	Refrigerant Type		R-410A	R-410A	R-410A	R-410A	
	Environ™ Coil System	Circuit 1	3.18 kg (7 lbs. 0 oz.)	3.18 kg (7 lbs. 0 oz.)	2.83 kg (6 lbs. 4 oz.)	2.83 kg (6 lbs. 4 oz.)	
		Circuit 2	3.15 kg (6 lbs. 15 oz.)	3.15 kg (6 lbs. 15 oz.)	2.55 kg (5 lbs. 10 oz.)	2.55 kg (5 lbs. 10 oz.)	
		Circuit 3	3.06 kg (6 lbs. 12 oz.)	3.06 kg (6 lbs. 12 oz.)	2.89 kg (6 lbs. 6 oz.)	2.89 kg (6 lbs. 6 oz.)	
		Circuit 4	---	---	2.72 kg (6 lbs. 0 oz.)	2.72 kg (6 lbs. 0 oz.)	
	Conventional Fin/Tube Coil Option	Circuit 1	6.35 kg (14 lbs. 0 oz.)	6.35 kg (14 lbs. 0 oz.)	4.76 kg (10 lbs. 8 oz.)	4.76 kg (10 lbs. 8 oz.)	
		Circuit 2	6.24 kg (13 lbs. 12 oz.)	6.24 kg (13 lbs. 12 oz.)	4.54 kg (10 lbs. 0 oz.)	4.54 kg (10 lbs. 0 oz.)	
		Circuit 3	5.44 kg (12 lbs. 0 oz.)	5.44 kg (12 lbs. 0 oz.)	4.42 kg (9 lbs. 12 oz.)	4.42 kg (9 lbs. 12 oz.)	
		Circuit 4	---	---	4.42 kg (9 lbs. 12 oz.)	4.42 kg (9 lbs. 12 oz.)	
	Electric Heat Available, see page 13			11.5, 23, 34.5, 45.9 kW			
Compressor Type (number)			Scroll (3)	Scroll (3)	Scroll (4)	Scroll (4)	
Outdoor Coils	Net face area (total) - m ² (sq. ft.)		5.13 (55.2)	5.13 (55.2)	5.13 (55.2)	5.13 (55.2)	
	Number of rows		1 (2)	1 (2)	1 (2)	1 (2)	
	Fins per m (Fins per inch)		906 (23) / 787(20)	906 (23) / 787(20)	906 (23) / 787(20)	906 (23) / 787(20)	
Outdoor Coil Fans	Motor - (No.) W (HP)		(4) 250 (1/3)	(4) 250 (1/3)	(6) 250 (1/3)	(6) 250 (1/3)	
	Motor rev/min		896	896	896	896	
	Total Motor watts		1146	1146	1490	1490	
	Diameter - (No.) mm (in.)		(4) 610 (24)	(4) 610 (24)	(4) 610 (24)	(4) 610 (24)	
	Number of blades		3	3	3	3	
	Total Air volume - L/s (cfm)		6275 (13 300)	6275 (13 300)	7880 (16 700)	7880 (16 700)	
Indoor Coils	Net face area (total) - m ² (sq. ft.)		1.99 (21.4)	1.99 (21.4)	1.99 (21.4)	1.99 (21.4)	
	Tube diameter - mm (in.)		9.5 (3/8)	9.5 (3/8)	9.5 (3/8)	9.5 (3/8)	
	Number of rows		4	4	4	4	
	Fins per m (Fins per inch)		551 (14)	551 (14)	551 (14)	551 (14)	
	Drain connection - No. and size		(1) 1 in. FPT	(1) 1 in. FPT	(1) 1 in. FPT	(1) 1 in. FPT	
	Expansion device type		Refrigerant Metering Orifice (RFC)		Balanced Port TXV, removable head		
³ Indoor Blower and Drive Selection	Nominal Motor kW (HP)		3.7 (5)	3.7 (5)	3.7 (5)	3.7 (5)	
	Maximum usable motor kW (HP)		4.3 (5.75)	4.3 (5.75)	4.3 (5.75)	4.3 (5.75)	
	Kit # (rev/min range)		#3 (571-721)	#3 (685-865)	#3 (571-721)	#3 (685-865)	
			#4 (708-871)	#4 (850-1045)	#4 (708-871)	#4 (850-1045)	
			#5 (788-988)	#5 (945-1185)	#5 (788-988)	#5 (945-1185)	
	Nominal Motor kW (HP)		5.6 (7.5)	5.6 (7.5)	5.6 (7.5)	5.6 (7.5)	
	Maximum usable motor kW (HP)		6.4 (8.6)	6.4 (8.6)	6.4 (8.6)	6.4 (8.6)	
	Kit # (rev/min range)		#6 (708-871)	#6 (850-1045)	#6 (708-871)	#6 (850-1045)	
			#7 (788-988)	#7 (945-1185)	#7 (788-988)	#7 (945-1185)	
			#8 (871-1071)	#8 (1045-1285)	#8 (871-1071)	#8 (1045-1285)	
	Nominal Motor kW (HP)		7.5 (10)	7.5 (10)	7.5 (10)	7.5 (10)	
	Maximum usable motor kW (HP)		8.6 (11.5)	8.6 (11.5)	8.6 (11.5)	8.6 (11.5)	
	Kit # (rev/min range)		#7 (788-988)	#7 (945-1185)	#7 (788-988)	#7 (945-1185)	
			#10 (871-1071)	#10 (1045-1285)	#10 (871-1071)	#10 (1045-1285)	
			#11 (945-1138)	#11 (1135-1365)	#11 (945-1138)	#11 (1135-1365)	
	Blower wheel nominal diameter x width - mm (in.)		(2) 381 x 381 (15 x 15)				
	Filters	Type of filter		Fiberglass, disposable			
		Number and size - mm (in.)		(6) 610 x 610 x 51 (24 x 24 x 2)			
Electrical characteristics			380/420V - 50 hertz - 3 phase				

NOTE - Net capacity includes evaporator blower motor heat deduction. Gross capacity does not include evaporator blower motor heat deduction.

¹ Rating test conditions are those included in Air Conditioning, Heating and Refrigeration Institute (AHRI) Standard 340/360; 35°C (95°F) outdoor air temperature and 27°C (80°F) db/19°C (67°F) wb entering evaporator air; minimum external duct static pressure while operating at rated voltage and air volumes.

² Rated at 46°C (115°F) outdoor air temperature and 27°C db/19°C (67°F) wb entering evaporator air (T3 Conditions).

³ Using total air volume and system static pressure requirements determine from blower performance tables rev/min and motor output required. Maximum usable output of motors furnished are shown. If motors of comparable output are used, be sure to keep within the service factor limitations outlined on the motor nameplate

NOTE - Units equipped with MSAV® (Multi-Stage Air Volume) option are limited to a motor service factor of 1.0.

SPECIFICATIONS - HIGH EFFICIENCY

General Data		Nominal kW (Tons)	45.7 (13)	52.8 kW (15)	61.5 (17.5)	70.3 (20)	
		Model Number	KCA156H4B	KCA180H4B	KCA210H4B	KCA240H4B	
		Efficiency Type	High	High	High	High	
		Blower Type	CAV (Constant Air Volume)	CAV (Constant Air Volume)	CAV (Constant Air Volume)	CAV (Constant Air Volume)	
Cooling Performance	Gross Cooling Capacity - kW (Btuh)		38.7 (132 000)	44.8 (153 000)	51.3 (175 000)	60.1 (205 000)	
	¹ Net Cooling Capacity - kW (Btuh)		37.1 (127 000)	43.4 (148 000)	49.5 (169 000)	58.0 (198 000)	
	Rated Air Flow - L/s (cfm)		2360 (5000)	2482 (5259)	2890 (6125)	3020 (6400)	
	Total Unit Power - kW		10.4	12.1	13.9	16.2	
	¹ EER (Btuh/Watt) at 35°C (95°F)		12.2	12.2	12.2	12.2	
	² EER (Btuh/Watt) at 46°C (115°F)		8.1	8.2	8.2	8.2	
	¹ IEER (Btuh/Watt)		13.2	13.5	13.0	13.2	
Refrigerant Charge	Refrigerant Type		R-410A	R-410A	R-410A	R-410A	
	Circuit 1		2.61 kg (5 lbs. 12 oz.)	2.72 kg (6 lbs. 0 oz.)	3.06 kg (6 lbs. 12 oz.)	2.83 kg (6 lbs. 4 oz.)	
	Circuit 2		2.49 kg (5 lbs. 4 oz.)	2.55 kg (5 lbs. 10 oz.)	3.12 kg (6 lbs. 14 oz.)	2.78 kg (6 lbs. 2 oz.)	
	Circuit 3		2.55 kg (5 lbs. 10 oz.)	2.66 kg (5 lbs. 14 oz.)	3.12 kg (6 lbs. 14 oz.)	2.66 kg (5 lbs. 14 oz.)	
	Circuit 4		---	---	---	2.44 kg (5 lbs. 6 oz.)	
Electric Heat Available, see page 14			11.5, 23, 34.5, 45.9 kW				
Compressor Type (number)			Scroll (3)	Scroll (3)	Scroll (3)	Scroll (4)	
Outdoor Coils	Net face area (total) - m ² (sq. ft.)		3.85 (41.4)	5.13 (55.2)	5.13 (55.2)	5.13 (55.2)	
	Number of rows		1	1	1	1	
	Fins per meter (Fins per inch)		906 (23)	906 (23)	906 (23)	906 (23)	
Outdoor Coil Fans	Motor - (No.) W (HP)		(3) 1/3	(4) 1/3	(6) 1/3	(6) 1/3	
	Motor rev/min		896	896	896	896	
	Total Motor watts		840	1146	1490	1490	
	Diameter - (No.) mm (in.)		(3) 610 (24)	(4) 610 (24)	(6) 610 (24)	(6) 610 (24)	
	Number of blades		3	3	3	3	
	Total Air volume - L/s (cfm)		4720 (10 000)	6300 (13 300)	7880 (16 700)	7880 (16 700)	
Indoor Coils	Net face area (total) - m ² (sq. ft.)		1.99 (21.4)	1.99 (21.4)	1.99 (21.4)	1.99 (21.4)	
	Tube diameter - in.		9.5 (3/8)	9.5 (3/8)	9.5 (3/8)	9.5 (3/8)	
	Number of rows		3	3	4	4	
	Fins per meter (Fins per inch)		551 (14)	551 (14)	551 (14)	551 (14)	
	Drain connection - No. and size		(1) 1 in. FPT	(1) 1 in. FPT	(1) 1 in. FPT	(1) 1 in. FPT	
		Expansion device type	Balance port TXV, removable head				
³ Indoor Blower and Drive Selection	Nominal Motor kW (HP)		1.5 (2)	2.2 (3)	2.2 (3)	3.7 (5)	
	Maximum usable motor kW (HP)		1.7 (2.3)	2.6 (3.45)	2.6 (3.45)	4.3 (5.75)	
	Kit # (rev/min range)		#1 (446-604) #2 (571-721)	#3 (571-721) #4 (708-871)	#3 (571-721) #4 (708-871)	#3 (571-721) #4 (708-871) #5 (788-988)	
	Nominal Motor kW (HP)		2.2 (3)	3.7 (5)	3.7 (5)	5.6 (7.5)	
	Maximum usable motor kW (HP)		2.6 (3.45)	4.3 (5.75)	4.3 (5.75)	6.4 (8.6)	
	Kit # (rev/min range)		#3 (571-721) #4 (708-871)	#3 (571-721) #4 (708-871) #5 (788-988)	#3 (571-721) #4 (708-871) #5 (788-988)	#6 (708-871) #7 (788-988) #8 (871-1071)	
	Nominal Motor kW (HP)		3.7 (5)	5.6 (7.5)	5.6 (7.5)	7.5 (10)	
	Maximum usable motor kW (HP)		4.3 (5.75)	6.4 (8.6)	6.4 (8.6)	8.6 (11.5)	
	Kit # (rev/min range)		#3 (571-721) #4 (708-871) #5 (788-988)	#6 (708-871) #7 (788-988) #8 (871-1071)	#6 (708-871) #7 (788-988) #8 (871-1071)	#7 (788-988) #10 (871-1071) #11 (945-1138)	
	Blower wheel nominal diameter x width - mm (in.)			(2) 381 x 381 (15 x 15)			
	Filters	Type of filter		Fiberglass, disposable			
		Number and size - mm (in.)		(6) 610 x 610 x 51 (24 x 24 x 2)			
Electrical characteristics			380/420V - 50 hertz - 3 phase				

NOTE - Net capacity includes evaporator blower motor heat deduction. Gross capacity does not include evaporator blower motor heat deduction.

¹ Rating test conditions are those included in Air-Conditioning, Heating and Refrigeration Institute (AHRI) Standard 340/360; 35°C (95°F) outdoor air temperature and 27°C (80°F) db/19°C (67°F) wb entering evaporator air; minimum external duct static pressure while operating at rated voltage and air volumes.

² Rated at 46°C (115°F) outdoor air temperature and 27°C db/19°C (67°F) wb entering evaporator air (T3 Conditions).

³ Using total air volume and system static pressure requirements determine from blower performance tables rev/min and motor output required. Maximum usable output of motors furnished are shown. See Belt Drive Specification Table for maximum usable motor output. If motors of comparable output are used, be sure to keep within the service factor limitations outlined on the motor nameplate.

NOTE - Units equipped with MSAV® (Multi-Stage Air Volume) option are limited to a motor service factor of 1.0.

RATINGS - STANDARD EFFICIENCY

NOTE - For Temperatures and Capacities not shown in tables, see bulletin - Cooling Unit Rating Table Correction Factor Data in Miscellaneous Engineering Data section.

52.8 kW - STANDARD EFFICIENCY KCB180S4B (1ST STAGE) - CONSTANT AIR VOLUME

Entering Wet Bulb Temperature	Total Air Volume	Outdoor Air Temperature Entering Outdoor Coil																			
		18.3°C					23.9°C					29.4°C					35°C				
		Total Cool Cap.	Comp. Motor Input	Sensible To Total Ratio (S/T)			Total Cool Cap.	Comp. Motor Input	Sensible To Total Ratio (S/T)			Total Cool Cap.	Comp. Motor Input	Sensible To Total Ratio (S/T)			Total Cool Cap.	Comp. Motor Input	Sensible To Total Ratio (S/T)		
				Dry Bulb					Dry Bulb					Dry Bulb					Dry Bulb		
L/s	kW	kW	24°C	27°C	29°C	kW	kW	24°C	27°C	29°C	kW	kW	24°C	27°C	29°C	kW	kW	24°C	27°C	29°C	
17.2°C	2265	33.0	4.53	.69	.82	.96	31.7	5.13	.70	.84	.98	30.3	5.78	.71	.86	.99	28.8	6.48	.73	.88	1.00
	2830	34.6	4.58	.73	.89	1.00	33.2	5.17	.75	.91	1.00	31.7	5.81	.76	.94	1.00	30.1	6.52	.78	.97	1.00
	3400	35.8	4.60	.78	.96	1.00	34.4	5.20	.80	.98	1.00	32.8	5.84	.81	.99	1.00	31.3	6.55	.84	1.00	1.00
19.4°C	2265	34.8	4.58	.55	.67	.78	33.5	5.18	.55	.68	.80	32.0	5.82	.56	.69	.82	30.5	6.53	.57	.70	.84
	2830	36.6	4.62	.57	.71	.85	35.1	5.22	.58	.72	.88	33.5	5.86	.59	.74	.90	31.8	6.57	.60	.76	.93
	3400	37.8	4.66	.60	.75	.93	36.2	5.25	.61	.77	.95	34.5	5.89	.62	.79	.97	32.8	6.60	.63	.82	.99
21.7°C	2265	36.6	4.63	.41	.53	.64	35.2	5.22	.42	.54	.65	33.7	5.86	.43	.54	.66	32.1	6.57	.42	.55	.68
	2830	38.5	4.67	.43	.56	.69	36.9	5.27	.43	.57	.70	35.3	5.91	.43	.58	.72	33.5	6.62	.44	.59	.73
	3400	39.7	4.71	.44	.59	.73	38.1	5.30	.44	.60	.75	36.4	5.95	.45	.61	.77	34.5	6.65	.45	.62	.79

52.8 kW - STANDARD EFFICIENCY KCB180S4B (2ND STAGE) - CONSTANT AIR VOLUME

Entering Wet Bulb Temperature	Total Air Volume	Outdoor Air Temperature Entering Outdoor Coil																			
		26.7°C					35°C					43.3°C					46°C				
		Total Cool Cap.	Comp. Motor Input	Sensible To Total Ratio (S/T)			Total Cool Cap.	Comp. Motor Input	Sensible To Total Ratio (S/T)			Total Cool Cap.	Comp. Motor Input	Sensible To Total Ratio (S/T)			Total Cool Cap.	Comp. Motor Input	Sensible To Total Ratio (S/T)		
				Dry Bulb					Dry Bulb					Dry Bulb					Dry Bulb		
L/s	kW	kW	24°C	27°C	29°C	kW	kW	24°C	27°C	29°C	kW	kW	24°C	27°C	29°C	kW	kW	24°C	27°C	29°C	
17.2°C	2265	45.2	9.04	.71	.88	1.00	41.8	10.72	.74	.93	1.00	38.3	12.73	.77	.98	1.00	37.2	13.47	.83	1.00	1.00
	2830	47.1	9.10	.76	.98	1.00	43.8	10.80	.80	1.00	1.00	40.5	12.84	.85	1.00	1.00	39.4	13.57	.91	1.00	1.00
	3400	49.0	9.17	.83	1.00	1.00	45.7	10.88	.88	1.00	1.00	42.2	12.92	.95	1.00	1.00	41.1	13.66	.97	1.00	1.00
19.4°C	2265	47.7	9.12	.56	.69	.84	44.2	10.81	.57	.71	.89	40.4	12.83	.59	.74	.95	39.2	13.56	.63	.80	.97
	2830	49.6	9.20	.59	.74	.94	45.8	10.88	.61	.77	.99	41.9	12.90	.63	.83	1.00	40.7	13.63	.67	.88	1.00
	3400	51.0	9.25	.62	.81	1.00	47.0	10.93	.64	.86	1.00	43.0	12.95	.67	.92	1.00	41.7	13.68	.72	.95	1.00
21.7°C	2265	50.1	9.22	.41	.54	.67	46.5	10.91	.42	.56	.69	42.7	12.93	.43	.58	.72	41.5	13.67	.44	.61	.78
	2830	52.2	9.30	.43	.58	.72	48.3	10.98	.43	.60	.75	44.1	13.01	.45	.62	.80	42.8	13.74	.47	.66	.86
	3400	53.5	9.35	.44	.61	.78	49.4	11.04	.45	.64	.83	45.1	13.06	.46	.66	.89	43.8	13.79	.49	.71	.93

Entering Wet Bulb Temperature	Total Air Volume	Outdoor Air Temperature Entering Outdoor Coil																	
		48°C					50°C					51.7°C							
		Total Cool Cap.	Comp. Motor Input	Sensible To Total Ratio (S/T)			Total Cool Cap.	Comp. Motor Input	Sensible To Total Ratio (S/T)			Total Cool Cap.	Comp. Motor Input	Sensible To Total Ratio (S/T)					
				Dry Bulb					Dry Bulb					Dry Bulb					
L/s	kW	kW	24°C	27°C	29°C	kW	kW	24°C	27°C	29°C	kW	kW	24°C	27°C	29°C				
17.2°C	2265	36.5	14.08	.79	1.00	1.00	35.7	14.74	.81	1.00	1.00	35.1	15.33	.82	1.00	1.00			
	2830	38.6	14.19	.89	1.00	1.00	37.8	14.85	.91	1.00	1.00	37.1	15.45	.92	1.00	1.00			
	3400	40.2	14.28	.98	1.00	1.00	39.4	14.93	.99	1.00	1.00	38.7	15.55	1.00	1.00	1.00			
19.4°C	2265	38.3	14.18	.60	.76	.98	37.4	14.82	.61	.77	.99	36.6	15.42	.61	.78	1.00			
	2830	39.7	14.24	.64	.86	1.00	38.7	14.89	.65	.88	1.00	37.9	15.49	.66	.89	1.00			
	3400	40.7	14.30	.69	.96	1.00	39.8	14.96	.69	.97	1.00	38.9	15.56	.70	.98	1.00			
21.7°C	2265	40.5	14.29	.43	.59	.74	39.6	14.94	.44	.60	.75	38.7	15.54	.44	.60	.76			
	2830	41.8	14.36	.45	.64	.83	40.8	15.01	.45	.64	.85	39.9	15.62	.46	.65	.86			
	3400	42.8	14.42	.48	.68	.93	41.8	15.07	.48	.69	.95	40.9	15.68	.48	.70	.96			

RATINGS - STANDARD EFFICIENCY

NOTE - For Temperatures and Capacities not shown in tables, see bulletin - Cooling Unit Rating Table Correction Factor Data in Miscellaneous Engineering Data section.

61.5 kW - STANDARD EFFICIENCY KCB210S4B (1ST STAGE) - CONSTANT AIR VOLUME

Entering Wet Bulb Temperature	Total Air Volume	Outdoor Air Temperature Entering Outdoor Coil																			
		18.3°C					23.9°C					29.4°C					35°C				
		Total Cool Cap.	Comp. Motor Input	Sensible To Total Ratio (S/T)			Total Cool Cap.	Comp. Motor Input	Sensible To Total Ratio (S/T)			Total Cool Cap.	Comp. Motor Input	Sensible To Total Ratio (S/T)			Total Cool Cap.	Comp. Motor Input	Sensible To Total Ratio (S/T)		
				Dry Bulb					Dry Bulb					Dry Bulb					Dry Bulb		
L/s	kW	kW	24°C	27°C	29°C	kW	kW	24°C	27°C	29°C	kW	kW	24°C	27°C	29°C	kW	kW	24°C	27°C	29°C	
17.2°C	2645	41.4	5.57	.67	.82	.99	38.6	6.28	.68	.84	1.00	35.6	7.05	.68	.87	1.00	32.5	7.94	.69	.90	1.00
	3305	43.9	5.63	.73	.92	1.00	40.9	6.34	.74	.95	1.00	37.8	7.12	.75	.98	1.00	34.6	8.01	.77	.99	1.00
	3965	45.8	5.68	.78	.99	1.00	42.9	6.40	.81	1.00	1.00	39.9	7.19	.83	1.00	1.00	36.9	8.08	.86	1.00	1.00
19.4°C	2645	44.6	5.65	.53	.65	.78	41.6	6.36	.52	.66	.80	38.5	7.14	.52	.66	.82	35.2	8.02	.52	.67	.86
	3305	46.9	5.71	.56	.71	.88	43.8	6.43	.56	.72	.91	40.4	7.20	.56	.73	.94	37.0	8.09	.56	.75	.98
	3965	48.6	5.76	.60	.76	.97	45.2	6.47	.60	.77	.99	41.8	7.25	.60	.81	1.00	38.3	8.13	.60	.84	1.00
21.7°C	2645	47.8	5.73	.40	.52	.63	44.7	6.45	.39	.52	.64	41.4	7.24	.38	.51	.65	38.0	8.13	.36	.51	.66
	3305	50.1	5.80	.41	.56	.69	46.9	6.52	.41	.56	.70	43.4	7.31	.40	.56	.71	39.7	8.20	.39	.56	.73
	3965	51.8	5.85	.43	.58	.74	48.4	6.58	.43	.59	.76	44.8	7.36	.41	.60	.79	41.0	8.24	.41	.60	.81

61.5 kW - STANDARD EFFICIENCY KCB210S4B (2ND STAGE) - CONSTANT AIR VOLUME

Entering Wet Bulb Temperature	Total Air Volume	Outdoor Air Temperature Entering Outdoor Coil																			
		26.7°C					35°C					43.3°C					46°C				
		Total Cool Cap.	Comp. Motor Input	Sensible To Total Ratio (S/T)			Total Cool Cap.	Comp. Motor Input	Sensible To Total Ratio (S/T)			Total Cool Cap.	Comp. Motor Input	Sensible To Total Ratio (S/T)			Total Cool Cap.	Comp. Motor Input	Sensible To Total Ratio (S/T)		
				Dry Bulb					Dry Bulb					Dry Bulb					Dry Bulb		
L/s	kW	kW	24°C	27°C	29°C	kW	kW	24°C	27°C	29°C	kW	kW	24°C	27°C	29°C	kW	kW	24°C	27°C	29°C	
17.2°C	2645	54.6	10.50	.69	.88	1.00	47.7	12.50	.71	.93	1.00	40.6	15.01	.73	.97	1.00	38.5	15.94	.79	.99	1.00
	3305	57.9	10.62	.76	.98	1.00	51.0	12.65	.79	1.00	1.00	44.1	15.17	.85	1.00	1.00	41.9	16.10	.90	1.00	1.00
	3965	61.1	10.75	.84	1.00	1.00	54.1	12.78	.89	1.00	1.00	46.8	15.30	.95	1.00	1.00	44.5	16.24	.97	1.00	1.00
19.4°C	2645	58.8	10.65	.53	.68	.84	51.5	12.66	.53	.69	.89	43.8	15.16	.52	.72	.94	41.4	16.08	.54	.77	.97
	3305	61.7	10.76	.57	.74	.95	53.8	12.77	.57	.77	.98	45.9	15.26	.58	.82	1.00	43.4	16.18	.61	.88	1.00
	3965	63.7	10.85	.61	.82	1.00	55.7	12.85	.62	.87	1.00	47.6	15.33	.64	.93	1.00	45.0	16.25	.68	.96	1.00
21.7°C	2645	63.0	10.82	.39	.52	.66	55.4	12.84	.36	.52	.67	47.5	15.33	.34	.52	.70	45.0	16.25	.34	.54	.75
	3305	65.9	10.94	.41	.57	.72	57.8	12.96	.39	.57	.75	49.6	15.44	.37	.58	.80	46.9	16.34	.37	.62	.86
	3965	67.9	11.04	.43	.61	.80	59.5	13.05	.41	.62	.85	51.1	15.53	.40	.64	.91	48.4	16.43	.41	.69	.95

Entering Wet Bulb Temperature	Total Air Volume	Outdoor Air Temperature Entering Outdoor Coil																	
		48°C					50°C					51.7°C							
		Total Cool Cap.	Comp. Motor Input	Sensible To Total Ratio (S/T)			Total Cool Cap.	Comp. Motor Input	Sensible To Total Ratio (S/T)			Total Cool Cap.	Comp. Motor Input	Sensible To Total Ratio (S/T)					
				Dry Bulb					Dry Bulb					Dry Bulb					
L/s	kW	kW	24°C	27°C	29°C	kW	kW	24°C	27°C	29°C	kW	kW	24°C	27°C	29°C				
17.2°C	2645	36.8	16.76	.75	.99	1.00	35.1	17.63	.76	1.00	1.00	33.6	18.42	.78	1.00	1.00			
	3305	40.2	16.90	.89	1.00	1.00	38.4	17.77	.91	1.00	1.00	36.8	18.59	.92	1.00	1.00			
	3965	42.6	17.02	.98	1.00	1.00	40.9	17.88	.99	1.00	1.00	39.2	18.71	.99	1.00	1.00			
19.4°C	2645	39.5	16.88	.52	.73	.97	37.6	17.74	.52	.75	.98	35.9	18.56	.52	.76	.99			
	3305	41.4	16.97	.59	.87	1.00	39.4	17.82	.59	.89	1.00	37.7	18.61	.60	.90	1.00			
	3965	43.0	17.05	.65	.96	1.00	41.1	17.90	.66	.97	1.00	39.3	18.72	.66	.98	1.00			
21.7°C	2645	43.0	17.04	.32	.52	.72	41.1	17.90	.31	.52	.73	39.2	18.70	.31	.52	.74			
	3305	44.9	17.14	.36	.59	.84	42.8	17.99	.35	.60	.86	41.0	18.79	.35	.60	.88			
	3965	46.3	17.21	.39	.66	.94	44.1	18.04	.39	.67	.96	42.2	18.87	.38	.67	.97			

RATINGS - STANDARD EFFICIENCY

NOTE - For Temperatures and Capacities not shown in tables, see bulletin - Cooling Unit Rating Table Correction Factor Data in Miscellaneous Engineering Data section.

70.3 kW - STANDARD EFFICIENCY KCB240S4B (1ST STAGE) - CONSTANT AIR VOLUME

Entering Wet Bulb Temperature	Total Air Volume	Outdoor Air Temperature Entering Outdoor Coil																			
		18.3°C					23.9°C					29.4°C					35°C				
		Total Cool Cap.	Comp. Motor Input	Sensible To Total Ratio (S/T)			Total Cool Cap.	Comp. Motor Input	Sensible To Total Ratio (S/T)			Total Cool Cap.	Comp. Motor Input	Sensible To Total Ratio (S/T)			Total Cool Cap.	Comp. Motor Input	Sensible To Total Ratio (S/T)		
				Dry Bulb					Dry Bulb					Dry Bulb					Dry Bulb		
L/s	kW	kW	24°C	27°C	29°C	kW	kW	24°C	27°C	29°C	kW	kW	24°C	27°C	29°C	kW	kW	24°C	27°C	29°C	
17.2°C	3020	44.2	6.24	.73	.88	1.00	41.9	6.94	.74	.89	1.00	39.4	7.71	.76	.91	1.00	36.8	8.57	.77	.94	1.00
	3775	46.4	6.26	.79	.95	1.00	44.0	6.97	.81	.97	1.00	41.4	7.74	.82	.99	1.00	38.7	8.60	.84	1.00	1.00
	4530	48.2	6.29	.85	1.00	1.00	45.8	7.00	.86	1.00	1.00	43.5	7.78	.88	1.00	1.00	40.9	8.64	.91	1.00	1.00
19.4°C	3020	47.0	6.27	.58	.71	.84	44.6	6.98	.58	.72	.86	42.0	7.75	.59	.74	.88	39.3	8.61	.60	.75	.91
	3775	49.2	6.30	.62	.77	.92	46.6	7.01	.62	.79	.94	43.8	7.79	.63	.80	.97	40.9	8.64	.63	.82	.99
	4530	50.8	6.32	.65	.83	.99	48.0	7.03	.65	.84	1.00	45.1	7.81	.66	.86	1.00	42.0	8.67	.67	.89	1.00
21.7°C	3020	49.9	6.30	.43	.56	.69	47.4	7.03	.43	.57	.70	44.7	7.80	.43	.58	.71	41.8	8.67	.42	.59	.73
	3775	52.3	6.34	.46	.61	.75	49.5	7.06	.45	.61	.77	46.5	7.84	.45	.62	.78	43.3	8.70	.45	.62	.80
	4530	53.7	6.36	.47	.64	.81	50.8	7.08	.47	.64	.82	47.7	7.86	.47	.66	.84	44.5	8.73	.46	.67	.87

70.3 kW - STANDARD EFFICIENCY KCB240S4B (2ND STAGE) - CONSTANT AIR VOLUME

Entering Wet Bulb Temperature	Total Air Volume	Outdoor Air Temperature Entering Outdoor Coil																			
		26.7°C					35°C					43.3°C					46°C				
		Total Cool Cap.	Comp. Motor Input	Sensible To Total Ratio (S/T)			Total Cool Cap.	Comp. Motor Input	Sensible To Total Ratio (S/T)			Total Cool Cap.	Comp. Motor Input	Sensible To Total Ratio (S/T)			Total Cool Cap.	Comp. Motor Input	Sensible To Total Ratio (S/T)		
				Dry Bulb					Dry Bulb					Dry Bulb					Dry Bulb		
L/s	kW	kW	24°C	27°C	29°C	kW	kW	24°C	27°C	29°C	kW	kW	24°C	27°C	29°C	kW	kW	24°C	27°C	29°C	
17.2°C	3020	63.0	12.24	.77	.93	1.00	56.6	14.28	.79	.96	1.00	50.3	16.76	.82	.98	1.00	48.5	17.67	.83	.99	1.00
	3775	66.2	12.35	.83	.99	1.00	60.0	14.40	.87	1.00	1.00	53.6	16.89	.91	1.00	1.00	51.6	17.80	.92	1.00	1.00
	4530	69.3	12.44	.90	1.00	1.00	62.8	14.51	.93	1.00	1.00	56.2	17.00	.97	1.00	1.00	54.2	17.91	.98	1.00	1.00
19.4°C	3020	67.1	12.38	.59	.75	.90	60.3	14.43	.60	.77	.93	53.4	16.89	.61	.80	.97	51.2	17.79	.61	.81	.98
	3775	69.8	12.48	.63	.82	.97	62.7	14.52	.65	.85	.99	55.4	16.98	.66	.89	1.00	53.2	17.88	.67	.90	1.00
	4530	71.8	12.55	.68	.88	1.00	64.4	14.59	.69	.92	1.00	57.1	17.06	.72	.96	1.00	54.8	17.95	.73	.97	1.00
21.7°C	3020	71.2	12.52	.43	.59	.73	64.2	14.57	.43	.59	.75	56.9	17.05	.42	.60	.78	54.7	17.94	.41	.61	.79
	3775	74.0	12.62	.45	.63	.80	66.5	14.68	.45	.64	.83	59.0	17.13	.44	.66	.87	56.7	18.03	.44	.66	.88
	4530	76.0	12.69	.47	.67	.86	68.3	14.75	.47	.69	.90	60.4	17.20	.47	.72	.95	58.1	18.10	.46	.73	.96

Entering Wet Bulb Temperature	Total Air Volume	Outdoor Air Temperature Entering Outdoor Coil																	
		48°C					50°C					51.7°C							
		Total Cool Cap.	Comp. Motor Input	Sensible To Total Ratio (S/T)			Total Cool Cap.	Comp. Motor Input	Sensible To Total Ratio (S/T)			Total Cool Cap.	Comp. Motor Input	Sensible To Total Ratio (S/T)					
				Dry Bulb					Dry Bulb					Dry Bulb					
L/s	kW	kW	24°C	27°C	29°C	kW	kW	24°C	27°C	29°C	kW	kW	24°C	27°C	29°C				
17.2°C	3020	47.1	18.44	.84	.99	1.00	45.6	19.25	.85	1.00	1.00	44.5	20.01	.86	1.00	1.00			
	3775	50.1	18.56	.93	1.00	1.00	48.8	19.37	.94	1.00	1.00	47.7	20.14	.95	1.00	1.00			
	4530	52.7	18.67	.98	1.00	1.00	51.2	19.48	.99	1.00	1.00	49.9	20.24	.99	1.00	1.00			
19.4°C	3020	49.6	18.55	.61	.82	.98	48.0	19.36	.61	.83	.98	46.7	20.12	.62	.83	.99			
	3775	51.6	18.63	.67	.91	1.00	50.1	19.45	.67	.92	1.00	48.7	20.21	.68	.93	1.00			
	4530	53.0	18.70	.73	.98	1.00	51.5	19.50	.74	.98	1.00	50.1	20.24	.74	.98	1.00			
21.7°C	3020	53.0	18.71	.41	.61	.80	51.4	19.50	.41	.61	.81	50.1	20.27	.40	.62	.81			
	3775	54.9	18.78	.44	.67	.89	53.3	19.58	.44	.67	.91	51.9	20.33	.43	.68	.91			
	4530	56.3	18.85	.47	.73	.97	54.6	19.64	.47	.74	.97	53.1	20.39	.47	.74	.98			

RATINGS - STANDARD EFFICIENCY

NOTE - For Temperatures and Capacities not shown in tables, see bulletin - Cooling Unit Rating Table Correction Factor Data in Miscellaneous Engineering Data section.

88 kW - STANDARD EFFICIENCY KCB300S4B (1ST STAGE) - CONSTANT AIR VOLUME

Entering Wet Bulb Temperature	Total Air Volume	Outdoor Air Temperature Entering Outdoor Coil																			
		18.3°C					23.9°C					29.4°C					35°C				
		Total Cool Cap.	Comp. Motor Input	Sensible To Total Ratio (S/T)			Total Cool Cap.	Comp. Motor Input	Sensible To Total Ratio (S/T)			Total Cool Cap.	Comp. Motor Input	Sensible To Total Ratio (S/T)			Total Cool Cap.	Comp. Motor Input	Sensible To Total Ratio (S/T)		
				Dry Bulb					Dry Bulb					Dry Bulb					Dry Bulb		
L/s	kW	kW	24°C	27°C	29°C	kW	kW	24°C	27°C	29°C	kW	kW	24°C	27°C	29°C	kW	kW	24°C	27°C	29°C	
17.2°C	3775	38	5.26	0.72	0.87	0.99	36.3	5.94	0.74	0.9	1	34.7	6.71	0.75	0.92	1	33.3	7.59	0.78	0.95	1
	4485	39.4	5.3	0.76	0.93	1	37.6	5.99	0.79	0.96	1	35.9	6.76	0.8	0.98	1	34.4	7.64	0.82	0.99	1
	5190	40.5	5.34	0.81	0.98	1	38.6	6.03	0.83	0.99	1	37	6.8	0.85	1	1	35.5	7.68	0.87	1	1
19.4°C	3775	40.1	5.33	0.57	0.7	0.84	38.2	6.02	0.58	0.71	0.86	36.6	6.79	0.59	0.74	0.88	35	7.66	0.6	0.75	0.91
	4485	41.4	5.37	0.59	0.74	0.9	39.6	6.07	0.61	0.77	0.93	37.7	6.83	0.62	0.78	0.95	36	7.7	0.63	0.8	0.97
	5190	42.5	5.41	0.62	0.79	0.96	40.4	6.1	0.64	0.81	0.98	38.5	6.86	0.64	0.83	0.99	36.7	7.74	0.65	0.85	1
21.7°C	3775	42.5	5.41	0.43	0.56	0.68	40.5	6.1	0.43	0.57	0.69	38.6	6.87	0.45	0.58	0.72	36.9	7.75	0.44	0.59	0.73
	4485	43.7	5.46	0.44	0.58	0.72	41.7	6.15	0.44	0.6	0.74	39.8	6.92	0.45	0.61	0.76	37.9	7.8	0.45	0.62	0.78
	5190	44.7	5.5	0.44	0.61	0.76	42.6	6.19	0.44	0.63	0.78	40.5	6.95	0.45	0.63	0.8	38.6	7.83	0.47	0.65	0.83

88 kW - STANDARD EFFICIENCY KCB300S4B (2ND STAGE) - CONSTANT AIR VOLUME

Entering Wet Bulb Temperature	Total Air Volume	Outdoor Air Temperature Entering Outdoor Coil																			
		26.7°C					35°C					43.3°C					46°C				
		Total Cool Cap.	Comp. Motor Input	Sensible To Total Ratio (S/T)			Total Cool Cap.	Comp. Motor Input	Sensible To Total Ratio (S/T)			Total Cool Cap.	Comp. Motor Input	Sensible To Total Ratio (S/T)			Total Cool Cap.	Comp. Motor Input	Sensible To Total Ratio (S/T)		
				Dry Bulb					Dry Bulb					Dry Bulb					Dry Bulb		
L/s	kW	kW	24°C	27°C	29°C	kW	kW	24°C	27°C	29°C	kW	kW	24°C	27°C	29°C	kW	kW	24°C	27°C	29°C	
17.2°C	3775	73.2	14	0.76	0.92	1	68.2	16.58	0.78	0.96	1	63.1	19.77	0.81	0.99	1	61.5	20.96	.84	1.00	1.00
	4485	75.6	14.13	0.8	0.98	1	70.4	16.71	0.83	1	1	65.6	19.94	0.87	1	1	64.1	21.14	.90	1.00	1.00
	5190	77.8	14.25	0.85	1	1	72.9	16.86	0.88	1	1	67.8	20.08	0.93	1	1	66.3	21.29	.95	1.00	1.00
19.4°C	3775	77.2	14.22	0.59	0.73	0.88	71.8	16.8	0.61	0.76	0.92	66.4	19.98	0.62	0.79	0.97	64.6	21.17	.64	.82	.98
	4485	79.5	14.35	0.62	0.78	0.95	73.8	16.92	0.64	0.81	0.99	68.1	20.1	0.66	0.85	1	66.3	21.28	.67	.88	1.00
	5190	81.2	14.45	0.64	0.82	1	75.3	17.02	0.66	0.86	1	69.4	20.19	0.69	0.91	1	67.6	21.37	.71	.93	1.00
21.7°C	3775	81.5	14.46	0.44	0.58	0.71	75.8	17.05	0.44	0.6	0.74	70	20.23	0.45	0.62	0.77	68.1	21.41	.46	.63	.80
	4485	83.8	14.6	0.45	0.61	0.76	77.7	17.16	0.46	0.63	0.79	71.7	20.34	0.47	0.65	0.83	69.8	21.53	.48	.67	.85
	5190	85.5	14.69	0.46	0.64	0.8	79.2	17.26	0.47	0.65	0.84	73.1	20.43	0.48	0.68	0.88	71.0	21.61	.49	.71	.91

Entering Wet Bulb Temperature	Total Air Volume	Outdoor Air Temperature Entering Outdoor Coil																		
		48°C					50°C					51.7°C								
		Total Cool Cap.	Comp. Motor Input	Sensible To Total Ratio (S/T)			Total Cool Cap.	Comp. Motor Input	Sensible To Total Ratio (S/T)			Total Cool Cap.	Comp. Motor Input	Sensible To Total Ratio (S/T)						
				Dry Bulb					Dry Bulb					Dry Bulb						
L/s	kW	kW	24°C	27°C	29°C	kW	kW	24°C	27°C	29°C	kW	kW	24°C	27°C	29°C					
17.2°C	3775	60.2	21.98	.83	1.00	1.00	59.0	23.07	.84	1.00	1.00	58	24.1	0.85	1	1				
	4485	62.8	22.16	.90	1.00	1.00	61.6	23.26	.91	1.00	1.00	60.5	24.27	0.92	1	1				
	5190	64.9	22.29	.96	1.00	1.00	63.5	23.39	.97	1.00	1.00	62.4	24.4	0.98	1	1				
19.4°C	3775	63.2	22.18	.63	.81	.99	61.8	23.27	.64	.82	1.00	60.4	24.25	0.65	0.83	1				
	4485	64.9	22.29	.67	.87	1.00	63.3	23.37	.68	.88	1.00	62	24.38	0.68	0.9	1				
	5190	66.1	22.37	.70	.94	1.00	64.6	23.46	.71	.95	1.00	63.2	24.45	0.72	0.96	1				
21.7°C	3775	66.7	22.43	.46	.63	.79	65.1	23.50	.46	.63	.80	63.8	24.49	0.47	0.64	0.81				
	4485	68.2	22.52	.48	.66	.85	66.7	23.61	.48	.67	.86	65.4	24.61	0.48	0.68	0.88				
	5190	69.4	22.62	.49	.70	.92	67.8	23.69	.49	.70	.93	66.4	24.68	0.49	0.71	0.94				

RATINGS - STANDARD EFFICIENCY

NOTE - For Temperatures and Capacities not shown in tables, see bulletin - Cooling Unit Rating Table Correction Factor Data in Miscellaneous Engineering Data section.

52.8 kW - STANDARD EFFICIENCY KCB180S4M (1ST STAGE) - MSAV® MULTI-STAGE AIR VOLUME

Entering Wet Bulb Temperature	Total Air Volume	Outdoor Air Temperature Entering Outdoor Coil																			
		18.3°C					23.9°C					29.4°C					35°C				
		Total Cool Cap.	Comp. Motor Input	Sensible To Total Ratio (S/T)			Total Cool Cap.	Comp. Motor Input	Sensible To Total Ratio (S/T)			Total Cool Cap.	Comp. Motor Input	Sensible To Total Ratio (S/T)			Total Cool Cap.	Comp. Motor Input	Sensible To Total Ratio (S/T)		
				Dry Bulb					Dry Bulb					Dry Bulb					Dry Bulb		
L/s	kW	kW	24°C	27°C	29°C	kW	kW	24°C	27°C	29°C	kW	kW	24°C	27°C	29°C	kW	kW	24°C	27°C	29°C	
17.2°C	1650	31.5	4.39	0.67	0.79	0.9	30.4	5.03	0.68	0.8	0.92	29.2	5.68	0.69	0.81	0.94	27.8	6.38	0.7	0.83	0.96
	1890	32.7	4.39	0.69	0.82	0.94	31.5	5.04	0.7	0.83	0.96	30.2	5.67	0.71	0.85	0.98	28.8	6.37	0.72	0.86	1
	2125	33.7	4.39	0.71	0.85	0.98	32.4	5.03	0.72	0.86	0.99	31.1	5.69	0.73	0.88	1	29.7	6.39	0.75	0.9	1
19.4°C	1650	33.4	4.4	0.54	0.65	0.75	32.2	5.04	0.55	0.65	0.76	30.9	5.67	0.55	0.66	0.77	29.6	6.37	0.56	0.67	0.79
	1890	34.6	4.39	0.55	0.67	0.78	33.4	5.03	0.55	0.68	0.79	32.1	5.68	0.56	0.69	0.81	30.7	6.38	0.57	0.7	0.83
	2125	35.7	4.4	0.56	0.69	0.81	34.4	5.04	0.57	0.7	0.83	33	5.69	0.57	0.71	0.84	31.6	6.39	0.58	0.72	0.86
21.7°C	1650	35.2	4.4	0.42	0.52	0.62	34	5.04	0.42	0.53	0.63	32.9	5.68	0.43	0.53	0.64	31.4	6.37	0.42	0.54	0.65
	1890	36.5	4.41	0.42	0.54	0.64	35.2	5.04	0.43	0.54	0.65	34	5.69	0.43	0.54	0.66	32.5	6.39	0.43	0.55	0.67
	2125	37.7	4.42	0.43	0.55	0.66	36.3	5.05	0.43	0.55	0.67	35	5.7	0.43	0.56	0.68	33.5	6.39	0.43	0.57	0.69

52.8 kW - STANDARD EFFICIENCY KCB180S4M (2ND STAGE) - MSAV® MULTI-STAGE AIR VOLUME

Entering Wet Bulb Temperature	Total Air Volume	Outdoor Air Temperature Entering Outdoor Coil																			
		26.7°C					35°C					43.3°C					46°C				
		Total Cool Cap.	Comp. Motor Input	Sensible To Total Ratio (S/T)			Total Cool Cap.	Comp. Motor Input	Sensible To Total Ratio (S/T)			Total Cool Cap.	Comp. Motor Input	Sensible To Total Ratio (S/T)			Total Cool Cap.	Comp. Motor Input	Sensible To Total Ratio (S/T)		
				Dry Bulb					Dry Bulb					Dry Bulb					Dry Bulb		
L/s	kW	kW	24°C	27°C	29°C	kW	kW	24°C	27°C	29°C	kW	kW	24°C	27°C	29°C	kW	kW	24°C	27°C	29°C	
17.2°C	2265	46.7	8.23	0.73	0.88	1.00	43	9.8	0.75	0.91	1.00	39	11.75	0.76	0.95	1.00	37.6	12.49	0.78	0.96	1.00
	2832	49.1	8.23	0.78	0.95	1.00	45.2	9.81	0.79	0.98	1.00	41.1	11.77	0.82	1.00	1.00	39.7	12.51	0.84	1.00	1.00
	3398	50.8	8.24	0.81	1.00	1.00	46.9	9.82	0.84	1.00	1.00	42.8	11.77	0.87	1.00	1.00	41.5	12.50	0.88	1.00	1.00
19.4°C	2265	49.3	8.24	0.57	0.71	0.84	45.5	9.8	0.58	0.72	0.87	41.5	11.76	0.59	0.74	0.9	40.1	12.49	0.59	0.76	0.92
	2832	51.8	8.24	0.6	0.76	0.92	47.6	9.8	0.60	0.77	0.95	43.2	11.77	0.61	0.79	0.98	41.7	12.48	0.62	0.81	0.99
	3398	53.3	8.24	0.62	0.79	0.98	49.1	9.81	0.63	0.82	1.00	44.3	11.75	0.64	0.84	1.00	42.8	12.51	0.65	0.86	1.00
21.7°C	2265	51.7	8.23	0.44	0.56	0.68	47.7	9.81	0.42	0.56	0.7	43.3	11.77	0.40	0.57	0.72	41.8	12.52	0.40	0.58	0.73
	2832	53.7	8.24	0.41	0.59	0.73	49.4	9.82	0.42	0.6	0.75	44.9	11.76	0.42	0.6	0.77	43.2	12.52	0.43	0.61	0.79
	3398	55.2	8.23	0.45	0.62	0.77	50.5	9.81	0.45	0.62	0.79	45.6	11.78	0.39	0.63	0.82	43.9	12.52	0.39	0.64	0.84

Entering Wet Bulb Temperature	Total Air Volume	Outdoor Air Temperature Entering Outdoor Coil																	
		48°C					50°C					51.7°C							
		Total Cool Cap.	Comp. Motor Input	Sensible To Total Ratio (S/T)			Total Cool Cap.	Comp. Motor Input	Sensible To Total Ratio (S/T)			Total Cool Cap.	Comp. Motor Input	Sensible To Total Ratio (S/T)					
				Dry Bulb					Dry Bulb					Dry Bulb					
L/s	kW	kW	24°C	27°C	29°C	kW	kW	24°C	27°C	29°C	kW	kW	24°C	27°C	29°C				
17.2°C	2265	36.6	13.11	0.79	0.97	1.00	35.6	13.77	0.80	0.98	1.00	34.7	14.35	0.79	0.99	1.00			
	2832	38.7	13.12	0.84	1.00	1.00	37.7	13.77	0.85	1.00	1.00	36.8	14.37	0.85	1.00	1.00			
	3398	40.4	13.13	0.89	1.00	1.00	39.2	13.78	0.90	1.00	1.00	38.4	14.37	0.90	1.00	1.00			
19.4°C	2265	38.9	13.10	0.59	0.76	0.93	37.9	13.76	0.59	0.77	0.94	36.9	14.33	0.59	0.76	0.95			
	2832	40.6	13.09	0.62	0.82	1.00	39.4	13.74	0.63	0.83	1.00	38.4	14.33	0.62	0.82	1.00			
	3398	41.5	13.12	0.66	0.87	1.00	40.3	13.79	0.66	0.88	1.00	39.2	14.39	0.65	0.88	1.00			
21.7°C	2265	40.7	13.12	0.40	0.59	0.74	39.4	13.79	0.41	0.59	0.75	38.5	14.36	0.42	0.58	0.74			
	2832	42.0	13.14	0.40	0.61	0.79	40.7	13.80	0.40	0.62	0.80	39.6	14.39	0.38	0.62	0.80			
	3398	42.6	13.15	0.39	0.65	0.85	41.4	13.80	0.40	0.65	0.85	40.2	14.41	0.4	0.65	0.85			

RATINGS - STANDARD EFFICIENCY

NOTE - For Temperatures and Capacities not shown in tables, see bulletin - Cooling Unit Rating Table Correction Factor Data in Miscellaneous Engineering Data section.

61.5 kW - STANDARD EFFICIENCY KCB210S4M (1ST STAGE) - MSAV® MULTI-STAGE AIR VOLUME

Entering Wet Bulb Temperature	Total Air Volume	Outdoor Air Temperature Entering Outdoor Coil																			
		18.3°C					23.9°C					29.4°C					35°C				
		Total Cool Cap.	Comp. Motor Input	Sensible To Total Ratio (S/T)			Total Cool Cap.	Comp. Motor Input	Sensible To Total Ratio (S/T)			Total Cool Cap.	Comp. Motor Input	Sensible To Total Ratio (S/T)			Total Cool Cap.	Comp. Motor Input	Sensible To Total Ratio (S/T)		
				Dry Bulb					Dry Bulb					Dry Bulb					Dry Bulb		
L/s	kW	kW	24°C	27°C	29°C	kW	kW	24°C	27°C	29°C	kW	kW	24°C	27°C	29°C	kW	kW	24°C	27°C	29°C	
17.2°C	1890	37.2	5.62	0.67	0.78	0.9	35.8	6.33	0.67	0.79	0.91	34.2	7.12	0.68	0.81	0.93	32.7	8.02	0.69	0.83	0.95
	2240	38.9	5.7	0.7	0.83	0.95	37.4	6.41	0.7	0.84	0.97	35.8	7.2	0.71	0.86	0.99	34.1	8.1	0.73	0.88	1
	2595	40.3	5.76	0.73	0.87	1	38.7	6.47	0.73	0.89	1	37.1	7.27	0.75	0.91	1	35.3	8.17	0.77	0.93	1
19.4°C	1890	39.6	5.73	0.54	0.64	0.75	38.1	6.45	0.54	0.65	0.76	36.5	7.24	0.55	0.66	0.77	34.8	8.14	0.55	0.67	0.79
	2240	41.4	5.81	0.56	0.67	0.79	39.8	6.52	0.56	0.68	0.8	38	7.32	0.57	0.69	0.82	36.3	8.23	0.58	0.71	0.84
	2595	42.8	5.88	0.57	0.7	0.83	41.1	6.59	0.58	0.71	0.85	39.3	7.39	0.59	0.72	0.87	37.4	8.3	0.6	0.74	0.89
21.7°C	1890	42.1	5.85	0.42	0.52	0.62	40.5	6.56	0.42	0.52	0.63	38.9	7.37	0.42	0.53	0.63	37.1	8.28	0.42	0.54	0.64
	2240	44.2	5.94	0.43	0.54	0.65	42.3	6.66	0.43	0.54	0.66	40.5	7.46	0.43	0.55	0.67	38.7	8.37	0.43	0.56	0.68
	2595	45.5	6	0.43	0.55	0.68	43.8	6.73	0.44	0.57	0.69	41.8	7.53	0.44	0.57	0.7	39.9	8.44	0.44	0.59	0.72

61.5 kW - STANDARD EFFICIENCY KCB210S4M (2ND STAGE) - MSAV® MULTI-STAGE AIR VOLUME

Entering Wet Bulb Temperature	Total Air Volume	Outdoor Air Temperature Entering Outdoor Coil																			
		26.7°C					35°C					43.3°C					46°C				
		Total Cool Cap.	Comp. Motor Input	Sensible To Total Ratio (S/T)			Total Cool Cap.	Comp. Motor Input	Sensible To Total Ratio (S/T)			Total Cool Cap.	Comp. Motor Input	Sensible To Total Ratio (S/T)			Total Cool Cap.	Comp. Motor Input	Sensible To Total Ratio (S/T)		
				Dry Bulb					Dry Bulb					Dry Bulb					Dry Bulb		
L/s	kW	kW	24°C	27°C	29°C	kW	kW	24°C	27°C	29°C	kW	kW	24°C	27°C	29°C	kW	kW	24°C	27°C	29°C	
17.2°C	1890	55.5	10.41	0.75	0.91	1.00	51.1	12.42	0.77	0.94	1.00	46.2	14.89	0.8	0.98	1.00	44.6	15.79	0.82	0.99	1.00
	2240	58.4	10.55	0.81	0.99	1.00	54	12.58	0.84	1.00	1.00	49.4	15.09	0.88	1.00	1.00	47.9	16.00	0.91	1.00	1.00
	2595	61.5	10.71	0.87	1.00	1.00	57	12.75	0.91	1.00	1.00	52.1	15.27	0.96	1.00	1.00	50.5	16.18	0.98	1.00	1.00
19.4°C	1890	59.1	10.58	0.58	0.72	0.87	54.4	12.6	0.59	0.75	0.9	49.2	15.08	0.6	0.77	0.95	47.4	15.97	0.61	0.80	0.97
	2240	61.8	10.72	0.61	0.79	0.96	56.8	12.75	0.63	0.81	0.99	51.3	15.2	0.65	0.85	1.00	49.5	16.09	0.67	0.88	1.00
	2595	63.7	10.83	0.66	0.85	1.00	58.5	12.85	0.68	0.89	1.00	53	15.31	0.70	0.94	1.00	51.1	16.21	0.73	0.96	1.00
21.7°C	1890	62.9	10.78	0.43	0.57	0.7	57.9	12.81	0.43	0.58	0.72	52.4	15.28	0.43	0.59	0.75	50.6	16.18	0.43	0.60	0.77
	2240	65.6	10.93	0.45	0.61	0.76	60.2	12.95	0.45	0.62	0.79	54.6	15.42	0.45	0.64	0.83	52.7	16.30	0.45	0.66	0.86
	2595	67.6	11.03	0.46	0.65	0.83	62.1	13.05	0.47	0.67	0.87	56.2	15.53	0.47	0.7	0.91	54.2	16.43	0.48	0.71	0.94

Entering Wet Bulb Temperature	Total Air Volume	Outdoor Air Temperature Entering Outdoor Coil																	
		48°C					50°C					51.7°C							
		Total Cool Cap.	Comp. Motor Input	Sensible To Total Ratio (S/T)			Total Cool Cap.	Comp. Motor Input	Sensible To Total Ratio (S/T)			Total Cool Cap.	Comp. Motor Input	Sensible To Total Ratio (S/T)					
				Dry Bulb					Dry Bulb					Dry Bulb					
L/s	kW	kW	24°C	27°C	29°C	kW	kW	24°C	27°C	29°C	kW	kW	24°C	27°C	29°C				
17.2°C	1890	43.4	16.52	0.83	1.00	1.00	42.2	17.29	0.84	1.00	1.00	41.3	17.99	0.84	1.00	1.00			
	2240	46.6	16.72	0.92	1.00	1.00	45.4	17.48	0.94	1.00	1.00	44.2	18.20	0.95	1.00	1.00			
	2595	49.2	16.89	0.99	1.00	1.00	47.9	17.68	0.99	1.00	1.00	46.7	18.38	1.00	1.00	1.00			
19.4°C	1890	46.0	16.69	0.62	0.81	0.98	44.7	17.44	0.62	0.82	0.99	43.3	18.12	0.62	0.81	0.99			
	2240	48.0	16.82	0.67	0.89	1.00	46.6	17.57	0.68	0.91	1.00	45.3	18.26	0.68	0.92	1.00			
	2595	49.7	16.93	0.73	0.97	1.00	48.2	17.67	0.74	0.98	1.00	46.8	18.38	0.74	0.99	1.00			
21.7°C	1890	49.1	16.89	0.43	0.61	0.78	47.7	17.63	0.43	0.61	0.79	46.4	18.34	0.43	0.61	0.79			
	2240	51.2	17.02	0.46	0.67	0.87	49.6	17.77	0.46	0.67	0.88	48.2	18.46	0.46	0.67	0.89			
	2595	52.7	17.13	0.48	0.73	0.95	51.1	17.90	0.49	0.74	0.97	49.6	18.57	0.49	0.73	0.97			

RATINGS - STANDARD EFFICIENCY

NOTE - For Temperatures and Capacities not shown in tables, see bulletin - Cooling Unit Rating Table Correction Factor Data in Miscellaneous Engineering Data section.

70.3 kW - STANDARD EFFICIENCY KCB240S4M (1ST STAGE) - MSAV® MULTI-STAGE AIR VOLUME

Entering Wet Bulb Temperature	Total Air Volume	Outdoor Air Temperature Entering Outdoor Coil																			
		18.3°C					23.9°C					29.4°C					35°C				
		Total Cool Cap.	Comp. Motor Input	Sensible To Total Ratio (S/T)			Total Cool Cap.	Comp. Motor Input	Sensible To Total Ratio (S/T)			Total Cool Cap.	Comp. Motor Input	Sensible To Total Ratio (S/T)			Total Cool Cap.	Comp. Motor Input	Sensible To Total Ratio (S/T)		
				Dry Bulb					Dry Bulb					Dry Bulb					Dry Bulb		
L/s	kW	kW	24°C	27°C	29°C	kW	kW	24°C	27°C	29°C	kW	kW	24°C	27°C	29°C	kW	kW	24°C	27°C	29°C	
17.2°C	2125	40.7	6.28	0.67	0.79	0.91	39.2	6.98	0.68	0.8	0.92	37.6	7.76	0.69	0.82	0.94	35.8	8.64	0.7	0.84	0.97
	2595	42.9	6.39	0.71	0.84	0.97	41.3	7.09	0.72	0.86	0.99	39.5	7.87	0.73	0.88	1	37.6	8.75	0.75	0.9	1
	3070	44.6	6.48	0.74	0.9	1	42.9	7.18	0.76	0.92	1	41.1	7.96	0.77	0.94	1	39.1	8.84	0.79	0.96	1
19.4°C	2125	43.4	6.42	0.54	0.65	0.75	41.8	7.12	0.55	0.66	0.77	40.1	7.9	0.55	0.66	0.78	38.2	8.79	0.56	0.68	0.8
	2595	45.7	6.54	0.56	0.68	0.81	44	7.24	0.57	0.69	0.82	42.1	8.02	0.57	0.7	0.84	40.1	8.89	0.58	0.72	0.86
	3070	47.4	6.63	0.58	0.72	0.86	45.7	7.32	0.59	0.73	0.88	43.7	8.1	0.6	0.75	0.9	41.6	8.98	0.61	0.77	0.93
21.7°C	2125	46.1	6.56	0.42	0.52	0.62	44.4	7.26	0.42	0.53	0.63	42.8	8.06	0.42	0.53	0.64	40.9	8.94	0.42	0.54	0.65
	2595	48.7	6.69	0.43	0.54	0.66	46.9	7.39	0.43	0.55	0.67	44.9	8.17	0.43	0.56	0.68	42.7	9.05	0.44	0.57	0.69
	3070	50.4	6.79	0.44	0.57	0.7	48.5	7.48	0.44	0.57	0.71	46.5	8.27	0.44	0.58	0.72	44.3	9.15	0.44	0.59	0.74

70.3 kW - STANDARD EFFICIENCY KCB240S4M (2ND STAGE) - MSAV® MULTI-STAGE AIR VOLUME

Entering Wet Bulb Temperature	Total Air Volume	Outdoor Air Temperature Entering Outdoor Coil																			
		26.7°C					35°C					43.3°C					46°C				
		Total Cool Cap.	Comp. Motor Input	Sensible To Total Ratio (S/T)			Total Cool Cap.	Comp. Motor Input	Sensible To Total Ratio (S/T)			Total Cool Cap.	Comp. Motor Input	Sensible To Total Ratio (S/T)			Total Cool Cap.	Comp. Motor Input	Sensible To Total Ratio (S/T)		
				Dry Bulb					Dry Bulb					Dry Bulb					Dry Bulb		
L/s	kW	kW	24°C	27°C	29°C	kW	kW	24°C	27°C	29°C	kW	kW	24°C	27°C	29°C	kW	kW	24°C	27°C	29°C	
17.2°C	3020	64.8	12.32	0.74	0.89	1.00	59.8	14.39	0.76	0.93	1.00	54.4	16.89	0.79	0.97	1.00	52.6	17.79	0.81	0.98	1.00
	3775	68.2	12.52	0.8	0.98	1.00	63.2	14.59	0.83	0.99	1.00	57.9	17.12	0.87	1.00	1.00	56.2	18.03	0.89	1.00	1.00
	4530	71.5	12.7	0.87	1.00	1.00	66.6	14.8	0.9	1.00	1.00	61	17.33	0.95	1.00	1.00	59.1	18.23	0.97	1.00	1.00
19.4°C	3020	68.9	12.56	0.58	0.71	0.86	63.7	14.62	0.59	0.74	0.89	57.9	17.12	0.6	0.77	0.94	55.9	18.01	0.61	0.79	0.95
	3775	72.1	12.74	0.62	0.78	0.95	66.4	14.79	0.63	0.81	0.98	60.3	17.28	0.65	0.84	1.00	58.2	18.17	0.66	0.87	1.00
	4530	74.3	12.87	0.65	0.84	1.00	68.5	14.92	0.67	0.88	1.00	62.4	17.42	0.69	0.93	1.00	60.2	18.30	0.71	0.95	1.00
21.7°C	3020	73.4	12.81	0.43	0.56	0.69	67.8	14.87	0.43	0.57	0.71	61.8	17.38	0.42	0.59	0.74	59.7	18.26	0.43	0.60	0.76
	3775	76.5	13	0.44	0.61	0.76	70.7	15.06	0.44	0.62	0.78	64.2	17.55	0.45	0.64	0.82	62.1	18.44	0.45	0.65	0.85
	4530	78.8	13.13	0.46	0.64	0.82	72.7	15.18	0.46	0.66	0.85	66	17.66	0.47	0.68	0.9	63.8	18.55	0.47	0.70	0.92

Entering Wet Bulb Temperature	Total Air Volume	Outdoor Air Temperature Entering Outdoor Coil																	
		48°C					50°C					51.7°C							
		Total Cool Cap.	Comp. Motor Input	Sensible To Total Ratio (S/T)			Total Cool Cap.	Comp. Motor Input	Sensible To Total Ratio (S/T)			Total Cool Cap.	Comp. Motor Input	Sensible To Total Ratio (S/T)					
				Dry Bulb					Dry Bulb					Dry Bulb					
L/s	kW	kW	24°C	27°C	29°C	kW	kW	24°C	27°C	29°C	kW	kW	24°C	27°C	29°C				
17.2°C	3020	51.3	18.51	0.82	0.99	1.00	49.9	19.27	0.83	0.99	1.00	48.7	19.96	0.83	1.00	1.00			
	3775	55.0	18.76	0.90	1.00	1.00	53.5	19.52	0.92	1.00	1.00	52.3	20.23	0.93	1.00	1.00			
	4530	57.8	18.96	0.98	1.00	1.00	56.3	19.73	0.98	1.00	1.00	55	20.41	0.99	1.00	1.00			
19.4°C	3020	54.4	18.72	0.61	0.80	0.97	52.8	19.47	0.62	0.81	0.98	51.4	20.14	0.62	0.8	0.98			
	3775	56.7	18.89	0.67	0.88	1.00	55.1	19.63	0.67	0.89	1.00	53.6	20.31	0.67	0.9	1.00			
	4530	58.5	19.02	0.72	0.96	1.00	56.9	19.77	0.73	0.97	1.00	55.4	20.44	0.73	0.98	1.00			
21.7°C	3020	58.1	18.99	0.43	0.61	0.77	56.5	19.74	0.43	0.61	0.78	55	20.4	0.43	0.61	0.78			
	3775	60.4	19.15	0.46	0.66	0.85	58.6	19.89	0.46	0.66	0.87	57.1	20.57	0.46	0.66	0.87			
	4530	62.0	19.26	0.48	0.71	0.94	60.2	20.00	0.49	0.72	0.95	58.7	20.71	0.48	0.72	0.96			

RATINGS - HIGH EFFICIENCY

NOTE - For Temperatures and Capacities not shown in tables, see bulletin - Cooling Unit Rating Table Correction Factor Data in Miscellaneous Engineering Data section.

88 kW - STANDARD EFFICIENCY KCB300S4M (1ST STAGE) - MSAV® MULTI-STAGE AIR VOLUME

Entering Wet Bulb Temperature	Total Air Volume	Outdoor Air Temperature Entering Outdoor Coil																			
		18.3°C					23.9°C					29.4°C					35°C				
		Total Cool Cap.	Comp. Motor Input	Sensible To Total Ratio (S/T)			Total Cool Cap.	Comp. Motor Input	Sensible To Total Ratio (S/T)			Total Cool Cap.	Comp. Motor Input	Sensible To Total Ratio (S/T)			Total Cool Cap.	Comp. Motor Input	Sensible To Total Ratio (S/T)		
				Dry Bulb					Dry Bulb					Dry Bulb					Dry Bulb		
L/s	kW	kW	24°C	27°C	29°C	kW	kW	24°C	27°C	29°C	kW	kW	24°C	27°C	29°C	kW	kW	24°C	27°C	29°C	
17.2°C	2715	37.9	5.15	0.66	0.78	0.9	36.5	5.85	0.66	0.79	0.91	35	6.62	0.67	0.8	0.93	33.4	7.49	0.68	0.82	0.95
	3185	39.5	5.19	0.68	0.81	0.94	38	5.89	0.68	0.83	0.96	36.5	6.67	0.7	0.84	0.97	34.8	7.53	0.71	0.86	0.97
	3660	40.8	5.23	0.7	0.85	0.97	39.2	5.93	0.71	0.87	0.97	37.6	6.71	0.73	0.89	0.97	35.9	7.57	0.74	0.91	0.97
19.4°C	2715	40.3	5.22	0.52	0.63	0.74	38.7	5.92	0.52	0.63	0.75	37.3	6.7	0.53	0.65	0.76	35.5	7.56	0.52	0.65	0.78
	3185	41.9	5.26	0.53	0.66	0.78	40.3	5.97	0.53	0.66	0.79	38.6	6.74	0.53	0.67	0.8	36.8	7.61	0.54	0.68	0.82
	3660	43.2	5.3	0.53	0.68	0.81	41.6	6.01	0.55	0.69	0.83	39.7	6.78	0.56	0.7	0.85	38	7.66	0.56	0.71	0.87
21.7°C	2715	42.6	5.29	0.39	0.5	0.6	41.3	6	0.39	0.5	0.61	39.5	6.77	0.39	0.5	0.62	37.9	7.65	0.39	0.51	0.63
	3185	44.5	5.35	0.39	0.51	0.62	42.8	6.05	0.38	0.5	0.63	41	6.83	0.37	0.51	0.64	39.1	7.7	0.38	0.52	0.65
	3660	45.7	5.39	0.39	0.52	0.65	43.9	6.09	0.39	0.52	0.66	42.1	6.87	0.39	0.54	0.67	40.2	7.75	0.39	0.54	0.69

88 kW - STANDARD EFFICIENCY KCB300S4M (2ND STAGE) - MSAV® MULTI-STAGE AIR VOLUME

Entering Wet Bulb Temperature	Total Air Volume	Outdoor Air Temperature Entering Outdoor Coil																			
		26.7°C					35°C					43.3°C					46°C				
		Total Cool Cap.	Comp. Motor Input	Sensible To Total Ratio (S/T)			Total Cool Cap.	Comp. Motor Input	Sensible To Total Ratio (S/T)			Total Cool Cap.	Comp. Motor Input	Sensible To Total Ratio (S/T)			Total Cool Cap.	Comp. Motor Input	Sensible To Total Ratio (S/T)		
				Dry Bulb					Dry Bulb					Dry Bulb					Dry Bulb		
L/s	kW	kW	24°C	27°C	29°C	kW	kW	24°C	27°C	29°C	kW	kW	24°C	27°C	29°C	kW	kW	24°C	27°C	29°C	
17.2°C	3775	77.4	13.96	0.73	0.89	0.98	71.3	16.52	0.75	0.93	0.98	64.7	19.63	0.78	0.96	0.98	62.5	20.76	0.80	0.98	0.98
	4485	80.4	14.11	0.78	0.95	0.98	74.2	16.67	0.8	0.97	0.98	68.1	19.82	0.83	0.97	0.98	66.0	20.96	0.86	0.97	0.98
	5190	83.3	14.24	0.82	0.98	0.98	77.5	16.85	0.85	0.97	0.98	70.9	19.98	0.89	0.97	0.98	68.8	21.12	0.92	0.97	0.98
19.4°C	3775	82.3	14.19	0.56	0.71	0.85	75.8	16.75	0.57	0.73	0.89	68.8	19.87	0.58	0.75	0.93	66.4	20.98	0.59	0.78	0.95
	4485	85.2	14.33	0.59	0.75	0.92	78.3	16.9	0.6	0.78	0.95	71	19.99	0.61	0.81	0.97	68.6	21.11	0.62	0.83	0.97
	5190	87.3	14.45	0.61	0.8	0.97	80.4	17.01	0.63	0.83	0.97	72.9	20.1	0.64	0.87	0.97	70.4	21.22	0.65	0.89	0.97
21.7°C	3775	87.5	14.45	0.41	0.55	0.68	80.8	17.02	0.4	0.56	0.7	73.5	20.13	0.4	0.57	0.73	71.0	21.25	0.40	0.58	0.75
	4485	90.4	14.6	0.41	0.58	0.73	83.3	17.16	0.41	0.59	0.75	75.6	20.27	0.41	0.6	0.78	73.1	21.39	0.41	0.61	0.81
	5190	92.6	14.71	0.42	0.6	0.77	85.3	17.28	0.42	0.61	0.8	77.5	20.38	0.42	0.63	0.84	74.8	21.50	0.43	0.65	0.86

Entering Wet Bulb Temperature	Total Air Volume	Outdoor Air Temperature Entering Outdoor Coil																	
		48°C					50°C					51.7°C							
		Total Cool Cap.	Comp. Motor Input	Sensible To Total Ratio (S/T)			Total Cool Cap.	Comp. Motor Input	Sensible To Total Ratio (S/T)			Total Cool Cap.	Comp. Motor Input	Sensible To Total Ratio (S/T)					
				Dry Bulb					Dry Bulb					Dry Bulb					
L/s	kW	kW	24°C	27°C	29°C	kW	kW	24°C	27°C	29°C	kW	kW	24°C	27°C	29°C				
17.2°C	3775	60.9	21.67	0.81	0.98	0.98	59.3	22.64	0.82	0.98	0.98	58	23.5	0.82	0.97	0.98			
	4485	64.4	21.88	0.87	0.97	0.98	62.7	22.84	0.88	0.97	0.98	61.3	23.72	0.89	0.97	0.98			
	5190	67.0	22.04	0.93	0.97	0.98	65.3	22.99	0.94	0.97	0.98	63.8	23.88	0.94	0.97	0.97			
19.4°C	3775	64.6	21.89	0.59	0.78	0.96	62.7	22.84	0.60	0.79	0.97	61	23.7	0.59	0.79	0.97			
	4485	66.8	22.02	0.63	0.84	0.97	64.8	22.97	0.64	0.86	0.97	63	23.82	0.63	0.86	0.97			
	5190	68.5	22.12	0.66	0.90	0.97	66.6	23.08	0.67	0.91	0.97	64.8	23.94	0.67	0.92	0.96			
21.7°C	3775	69.0	22.14	0.40	0.58	0.76	67.0	23.09	0.40	0.59	0.77	65.3	23.96	0.39	0.58	0.76			
	4485	71.2	22.29	0.41	0.62	0.82	69.1	23.23	0.42	0.62	0.83	67.3	24.1	0.41	0.62	0.83			
	5190	72.7	22.39	0.43	0.65	0.87	70.7	23.34	0.42	0.66	0.89	68.8	24.2	0.42	0.66	0.89			

RATINGS - HIGH EFFICIENCY

NOTE - For Temperatures and Capacities not shown in tables, see bulletin - Cooling Unit Rating Table Correction Factor Data in Miscellaneous Engineering Data section.

45.7 kW - HIGH EFFICIENCY KCA156H4B (1ST STAGE) CONSTANT AIR VOLUME

Entering Wet Bulb Temperature	Total Air Volume	Outdoor Air Temperature Entering Outdoor Coil																							
		18.3°C						23.9°C						29.4°C						35°C					
		Total Cool Cap.	Comp. Motor Input	Sensible To Total Ratio (S/T)			Total Cool Cap.	Comp. Motor Input	Sensible To Total Ratio (S/T)			Total Cool Cap.	Comp. Motor Input	Sensible To Total Ratio (S/T)			Total Cool Cap.	Comp. Motor Input	Sensible To Total Ratio (S/T)						
				Dry Bulb					Dry Bulb					Dry Bulb					Dry Bulb						
L/s	kW	kW	24°C	27°C	29°C	kW	kW	24°C	27°C	29°C	kW	kW	24°C	27°C	29°C	kW	kW	24°C	27°C	29°C					
17.2°C	1965	28.6	3.87	0.71	0.85	0.99	26.6	4.38	0.71	0.86	1.00	24.6	4.94	0.72	0.88	1.00	22.5	5.57	0.72	0.91	1.00				
	2455	30.3	3.9	0.76	0.93	1.00	28.2	4.41	0.77	0.95	1.00	26.1	4.97	0.78	0.97	1.00	24.0	5.60	0.79	0.99	1.00				
	2945	31.6	3.93	0.81	0.99	1.00	29.6	4.44	0.83	1.00	1.00	27.6	5.00	0.85	1.00	1.00	25.6	5.64	0.87	1.00	1.00				
19.4°C	1965	30.7	3.91	0.56	0.68	0.81	28.7	4.42	0.55	0.69	0.83	26.6	4.98	0.54	0.69	0.84	24.4	5.61	0.54	0.70	0.87				
	2455	32.4	3.95	0.59	0.74	0.90	30.3	4.45	0.59	0.75	0.92	28.1	5.01	0.59	0.76	0.94	25.9	5.64	0.59	0.77	0.96				
	2945	33.8	3.98	0.62	0.79	0.97	31.5	4.48	0.62	0.81	0.99	29.2	5.04	0.63	0.82	0.99	26.9	5.67	0.63	0.85	1.00				
21.7°C	1965	32.7	3.95	0.42	0.55	0.66	30.6	4.46	0.41	0.54	0.67	28.5	5.02	0.39	0.54	0.67	26.3	5.65	0.37	0.53	0.68				
	2455	34.6	3.99	0.44	0.58	0.72	32.4	4.50	0.42	0.58	0.73	30.1	5.06	0.41	0.58	0.74	27.9	5.69	0.40	0.58	0.75				
	2945	35.9	4.03	0.45	0.62	0.77	33.7	4.53	0.44	0.62	0.78	31.3	5.09	0.43	0.62	0.80	28.9	5.72	0.42	0.63	0.82				

45.7 kW - HIGH EFFICIENCY KCA156H4B (2ND STAGE) CONSTANT AIR VOLUME

Entering Wet Bulb Temperature	Total Air Volume	Outdoor Air Temperature Entering Outdoor Coil																							
		26.7°C						35°C						43.3°C						46°C					
		Total Cool Cap.	Comp. Motor Input	Sensible To Total Ratio (S/T)			Total Cool Cap.	Comp. Motor Input	Sensible To Total Ratio (S/T)			Total Cool Cap.	Comp. Motor Input	Sensible To Total Ratio (S/T)			Total Cool Cap.	Comp. Motor Input	Sensible To Total Ratio (S/T)						
				Dry Bulb					Dry Bulb					Dry Bulb					Dry Bulb						
L/s	kW	kW	24°C	27°C	29°C	kW	kW	24°C	27°C	29°C	kW	kW	24°C	27°C	29°C	kW	kW	24°C	27°C	29°C					
17.2°C	1965	39.3	7.04	0.74	0.91	1.00	34.6	8.43	0.76	0.95	1.00	29.7	10.11	0.78	0.99	1.00	28.2	10.73	.79	.99	1.00				
	2455	41.6	7.09	0.81	0.99	1.00	37.1	8.48	0.83	1.00	1.00	32.4	10.18	0.87	1.00	1.00	30.9	10.79	.89	1.00	1.00				
	2945	44.0	7.15	0.87	1.00	1.00	39.4	8.54	0.91	1.00	1.00	34.6	10.24	0.96	1.00	1.00	33.0	10.85	.97	1.00	1.00				
19.4°C	1965	42.3	7.11	0.57	0.72	0.87	37.5	8.49	0.56	0.74	0.91	32.3	10.18	0.56	0.75	0.95	30.7	10.79	.55	.77	.97				
	2455	44.6	7.16	0.61	0.79	0.96	39.5	8.54	0.61	0.81	0.99	34.1	10.23	0.61	0.85	1.00	32.4	10.83	.62	.87	1.00				
	2945	46.2	7.2	0.65	0.85	1.00	40.9	8.58	0.66	0.89	1.00	35.4	10.26	0.67	0.93	1.00	33.6	10.87	.68	.95	1.00				
21.7°C	1965	45.3	7.17	0.41	0.56	0.70	40.3	8.56	0.39	0.56	0.71	35.1	10.25	0.37	0.55	0.73	33.4	10.86	.35	.55	.75				
	2455	47.7	7.23	0.43	0.60	0.77	42.5	8.62	0.41	0.61	0.79	37.0	10.30	0.39	0.61	0.82	35.2	10.91	.38	.62	.84				
	2945	49.5	7.28	0.45	0.64	0.83	44.0	8.66	0.43	0.65	0.86	38.3	10.34	0.42	0.67	0.91	36.5	10.95	.41	.68	.93				

Entering Wet Bulb Temperature	Total Air Volume	Outdoor Air Temperature Entering Outdoor Coil																	
		48°C						50°C						51.7°C					
		Total Cool Cap.	Comp. Motor Input	Sensible To Total Ratio (S/T)			Total Cool Cap.	Comp. Motor Input	Sensible To Total Ratio (S/T)			Total Cool Cap.	Comp. Motor Input	Sensible To Total Ratio (S/T)					
				Dry Bulb					Dry Bulb					Dry Bulb					
L/s	kW	kW	24°C	27°C	29°C	kW	kW	24°C	27°C	29°C	kW	kW	24°C	27°C	29°C				
17.2°C	1965	27.0	11.23	0.79	1.00	1.00	25.9	11.74	0.81	1.00	1.00	25.0	12.20	0.81	1.00	1.00			
	2455	29.7	11.30	0.90	1.00	1.00	28.5	11.81	0.92	1.00	1.00	27.5	12.27	0.93	1.00	1.00			
	2945	31.8	11.35	0.98	1.00	1.00	30.5	11.87	0.99	1.00	1.00	29.5	12.32	1.00	1.00	1.00			
19.4°C	1965	29.4	11.29	0.55	0.77	0.98	28.1	11.80	0.55	0.78	0.99	27.0	12.25	0.55	0.79	0.99			
	2455	31.0	11.33	0.62	0.87	1.00	29.7	11.84	0.62	0.89	1.00	28.5	12.30	0.62	0.90	1.00			
	2945	32.2	11.37	0.68	0.96	1.00	30.9	11.88	0.68	0.98	1.00	29.7	12.33	0.69	0.99	1.00			
21.7°C	1965	32.0	11.36	0.34	0.55	0.75	30.7	11.87	0.33	0.55	0.76	29.6	12.32	0.32	0.55	0.76			
	2455	33.8	11.41	0.38	0.62	0.85	32.4	11.92	0.37	0.62	0.86	31.2	12.37	0.36	0.62	0.87			
	2945	35.0	11.45	0.41	0.68	0.94	33.6	11.96	0.40	0.69	0.95	32.4	12.41	0.40	0.69	0.96			

RATINGS - HIGH EFFICIENCY

NOTE - For Temperatures and Capacities not shown in tables, see bulletin - Cooling Unit Rating Table Correction Factor Data in Miscellaneous Engineering Data section.

52.8 kW - HIGH EFFICIENCY KCA180H4B (1ST STAGE) - CONSTANT AIR VOLUME

Entering Wet Bulb Temperature	Total Air Volume	Outdoor Air Temperature Entering Outdoor Coil																			
		18.3°C					23.9°C					29.4°C					35°C				
		Total Cool Cap.	Comp. Motor Input	Sensible To Total Ratio (S/T)			Total Cool Cap.	Comp. Motor Input	Sensible To Total Ratio (S/T)			Total Cool Cap.	Comp. Motor Input	Sensible To Total Ratio (S/T)			Total Cool Cap.	Comp. Motor Input	Sensible To Total Ratio (S/T)		
				Dry Bulb					Dry Bulb					Dry Bulb					Dry Bulb		
L/s	kW	kW	24°C	27°C	29°C	kW	kW	24°C	27°C	29°C	kW	kW	24°C	27°C	29°C	kW	kW	24°C	27°C	29°C	
17.2°C	2265	33.1	4.13	0.73	0.86	0.98	31.1	4.77	0.73	0.87	0.99	28.9	5.46	0.74	0.89	1.00	26.7	6.22	0.75	0.90	1.00
	2830	35.1	4.14	0.78	0.93	1.00	32.9	4.78	0.79	0.94	1.00	30.6	5.48	0.80	0.96	1.00	28.3	6.25	0.81	0.98	1.00
	3400	36.5	4.14	0.83	0.98	1.00	34.3	4.79	0.84	1.00	1.00	32.1	5.49	0.85	1.00	1.00	29.9	6.26	0.87	1.00	1.00
19.4°C	2265	35.5	4.14	0.58	0.71	0.83	33.3	4.78	0.57	0.71	0.84	31.1	5.48	0.57	0.71	0.85	28.8	6.25	0.56	0.72	0.87
	2830	37.5	4.14	0.61	0.76	0.90	35.3	4.79	0.61	0.77	0.91	32.9	5.50	0.61	0.78	0.93	30.5	6.27	0.61	0.79	0.95
	3400	39.0	4.14	0.64	0.81	0.95	36.7	4.80	0.65	0.82	0.97	34.2	5.51	0.65	0.83	0.99	31.7	6.29	0.65	0.85	1.00
21.7°C	2265	37.7	4.14	0.44	0.57	0.69	35.5	4.79	0.43	0.56	0.69	33.3	5.50	0.41	0.56	0.69	30.9	6.28	0.40	0.55	0.70
	2830	39.9	4.15	0.45	0.60	0.74	37.6	4.81	0.44	0.60	0.75	35.1	5.52	0.43	0.60	0.76	32.6	6.30	0.42	0.60	0.77
	3400	41.4	4.15	0.46	0.63	0.79	39.0	4.81	0.45	0.64	0.80	36.5	5.53	0.45	0.64	0.81	33.9	6.31	0.44	0.64	0.83

52.8 kW - HIGH EFFICIENCY KCA180H4B (2ND STAGE) - CONSTANT AIR VOLUME

Entering Wet Bulb Temperature	Total Air Volume	Outdoor Air Temperature Entering Outdoor Coil																			
		26.7°C					35°C					43.3°C					46°C				
		Total Cool Cap.	Comp. Motor Input	Sensible To Total Ratio (S/T)			Total Cool Cap.	Comp. Motor Input	Sensible To Total Ratio (S/T)			Total Cool Cap.	Comp. Motor Input	Sensible To Total Ratio (S/T)			Total Cool Cap.	Comp. Motor Input	Sensible To Total Ratio (S/T)		
				Dry Bulb					Dry Bulb					Dry Bulb					Dry Bulb		
L/s	kW	kW	24°C	27°C	29°C	kW	kW	24°C	27°C	29°C	kW	kW	24°C	27°C	29°C	kW	kW	24°C	27°C	29°C	
17.2°C	2265	45.7	7.68	0.75	0.91	1.00	40.6	9.36	0.76	0.94	1.00	35.2	11.30	0.78	0.98	1.00	33.4	11.99	.79	.99	1.00
	2830	48.3	7.7	0.81	0.99	1.00	43.2	9.39	0.83	1.00	1.00	38.1	11.36	0.87	1.00	1.00	36.3	12.05	.89	1.00	1.00
	3400	50.8	7.72	0.87	1.00	1.00	45.8	9.43	0.90	1.00	1.00	40.4	11.41	0.95	1.00	1.00	38.6	12.10	.97	1.00	1.00
19.4°C	2265	49.1	7.71	0.57	0.73	0.87	43.9	9.40	0.57	0.74	0.91	38.1	11.36	0.57	0.76	0.95	36.2	12.04	.57	.77	.96
	2830	51.7	7.73	0.62	0.79	0.96	46.1	9.43	0.62	0.81	0.99	40.1	11.40	0.62	0.85	1.00	38.0	12.09	.63	.86	1.00
	3400	53.5	7.74	0.65	0.85	1.00	47.7	9.45	0.66	0.88	1.00	41.4	11.43	0.67	0.93	1.00	39.4	12.12	.68	.95	1.00
21.7°C	2265	52.4	7.73	0.42	0.56	0.70	47.0	9.44	0.40	0.56	0.72	41.1	11.42	0.38	0.56	0.74	39.1	12.11	.37	.57	.75
	2830	55.1	7.75	0.43	0.61	0.77	49.4	9.48	0.42	0.61	0.79	43.2	11.46	0.40	0.62	0.82	41.1	12.15	.40	.62	.84
	3400	57.0	7.77	0.45	0.65	0.83	51.0	9.50	0.44	0.66	0.86	44.6	11.49	0.43	0.68	0.91	42.4	12.18	.43	.68	.92

Entering Wet Bulb Temperature	Total Air Volume	Outdoor Air Temperature Entering Outdoor Coil																	
		48°C					50°C					51.7°C							
		Total Cool Cap.	Comp. Motor Input	Sensible To Total Ratio (S/T)			Total Cool Cap.	Comp. Motor Input	Sensible To Total Ratio (S/T)			Total Cool Cap.	Comp. Motor Input	Sensible To Total Ratio (S/T)					
				Dry Bulb					Dry Bulb					Dry Bulb					
L/s	kW	kW	24°C	27°C	29°C	kW	kW	24°C	27°C	29°C	kW	kW	24°C	27°C	29°C				
17.2°C	2265	32.1	12.53	0.80	1.00	1.00	30.7	13.09	0.81	1.00	1.00	29.6	13.58	0.82	1.00	1.00			
	2830	35.0	12.60	0.90	1.00	1.00	33.6	13.17	0.91	1.00	1.00	32.3	13.65	0.93	1.00	1.00			
	3400	37.1	12.65	0.98	1.00	1.00	35.7	13.21	0.99	1.00	1.00	34.4	13.70	1.00	1.00	1.00			
19.4°C	2265	34.7	12.60	0.57	0.78	0.98	33.1	13.15	0.57	0.79	0.99	31.9	13.64	0.57	0.80	1.00			
	2830	36.4	12.64	0.63	0.88	1.00	34.8	13.19	0.63	0.89	1.00	33.4	13.68	0.64	0.90	1.00			
	3400	37.7	12.67	0.69	0.96	1.00	36.1	13.23	0.69	0.98	1.00	34.7	13.72	0.70	0.99	1.00			
21.7°C	2265	37.6	12.66	0.36	0.57	0.76	35.9	13.22	0.35	0.57	0.77	34.6	13.71	0.34	0.57	0.78			
	2830	39.5	12.71	0.39	0.63	0.85	37.7	13.27	0.39	0.63	0.87	36.3	13.76	0.38	0.64	0.88			
	3400	40.7	12.74	0.42	0.69	0.94	38.9	13.30	0.42	0.70	0.95	37.5	13.79	0.42	0.71	0.97			

RATINGS - HIGH EFFICIENCY

NOTE - For Temperatures and Capacities not shown in tables, see bulletin - Cooling Unit Rating Table Correction Factor Data in Miscellaneous Engineering Data section.

61.5 kW - HIGH EFFICIENCY KCA210H4B (1ST STAGE) - CONSTANT AIR VOLUME

Entering Wet Bulb Temperature	Total Air Volume	Outdoor Air Temperature Entering Outdoor Coil																			
		18.3°C					23.9°C					29.4°C					35°C				
		Total Cool Cap.	Comp. Motor Input	Sensible To Total Ratio (S/T)			Total Cool Cap.	Comp. Motor Input	Sensible To Total Ratio (S/T)			Total Cool Cap.	Comp. Motor Input	Sensible To Total Ratio (S/T)			Total Cool Cap.	Comp. Motor Input	Sensible To Total Ratio (S/T)		
				Dry Bulb					Dry Bulb					Dry Bulb					Dry Bulb		
L/s	kW	kW	24°C	27°C	29°C	kW	kW	24°C	27°C	29°C	kW	kW	24°C	27°C	29°C	kW	kW	24°C	27°C	29°C	
17.2°C	2645	36.8	4.54	0.75	0.90	1.00	34.5	5.17	0.76	0.92	1.00	32.0	5.85	0.77	0.94	1.00	29.5	6.61	0.79	0.97	1.00
	3305	38.9	4.58	0.81	0.98	1.00	36.4	5.21	0.83	1.00	1.00	34.1	5.90	0.84	1.00	1.00	31.8	6.66	0.86	1.00	1.00
	3965	40.9	4.63	0.87	1.00	1.00	38.6	5.26	0.89	1.00	1.00	36.1	5.95	0.91	1.00	1.00	33.6	6.72	0.94	1.00	1.00
19.4°C	2645	39.4	4.6	0.59	0.73	0.87	37.0	5.23	0.59	0.74	0.89	34.5	5.91	0.59	0.75	0.91	31.9	6.67	0.59	0.76	0.93
	3305	41.4	4.64	0.63	0.79	0.95	38.8	5.27	0.63	0.81	0.97	36.1	5.95	0.62	0.82	0.99	33.3	6.71	0.64	0.84	1.00
	3965	42.8	4.67	0.66	0.85	1.00	40.1	5.30	0.67	0.87	1.00	37.3	5.98	0.67	0.89	1.00	34.5	6.74	0.68	0.92	1.00
21.7°C	2645	42.3	4.66	0.44	0.58	0.71	39.7	5.29	0.43	0.58	0.72	37.0	5.98	0.42	0.58	0.73	34.3	6.74	0.41	0.58	0.74
	3305	44.2	4.71	0.46	0.62	0.77	41.5	5.34	0.45	0.62	0.79	38.7	6.02	0.44	0.62	0.80	35.8	6.78	0.43	0.63	0.82
	3965	45.6	4.74	0.47	0.65	0.83	42.8	5.37	0.44	0.66	0.85	39.8	6.06	0.47	0.67	0.87	36.8	6.81	0.45	0.68	0.89

61.5 kW - HIGH EFFICIENCY KCA210H4B (2ND STAGE) - CONSTANT AIR VOLUME

Entering Wet Bulb Temperature	Total Air Volume	Outdoor Air Temperature Entering Outdoor Coil																			
		26.7°C					35°C					43.3°C					46°C				
		Total Cool Cap.	Comp. Motor Input	Sensible To Total Ratio (S/T)			Total Cool Cap.	Comp. Motor Input	Sensible To Total Ratio (S/T)			Total Cool Cap.	Comp. Motor Input	Sensible To Total Ratio (S/T)			Total Cool Cap.	Comp. Motor Input	Sensible To Total Ratio (S/T)		
				Dry Bulb					Dry Bulb					Dry Bulb					Dry Bulb		
L/s	kW	kW	24°C	27°C	29°C	kW	kW	24°C	27°C	29°C	kW	kW	24°C	27°C	29°C	kW	kW	24°C	27°C	29°C	
17.2°C	2645	52.3	8.76	0.76	0.92	1.00	46.7	10.53	0.77	0.95	1.00	40.8	12.65	0.80	0.99	1.00	38.9	13.41	.81	.99	1.00
	3305	55.5	8.83	0.82	0.99	1.00	49.9	10.61	0.85	1.00	1.00	44.2	12.74	0.89	1.00	1.00	42.3	13.50	.91	1.00	1.00
	3965	58.6	8.91	0.88	1.00	1.00	52.9	10.69	0.92	1.00	1.00	46.9	12.81	0.97	1.00	1.00	44.8	13.57	.98	1.00	1.00
19.4°C	2645	56.3	8.85	0.58	0.73	0.88	50.3	10.62	0.58	0.75	0.92	43.9	12.73	0.58	0.77	0.96	41.9	13.49	.59	.79	.98
	3305	59.1	8.92	0.62	0.80	0.97	52.7	10.68	0.63	0.82	0.99	46.1	12.79	0.64	0.86	1.00	44.0	13.54	.64	.89	1.00
	3965	61.1	8.97	0.65	0.87	1.00	54.5	10.73	0.67	0.90	1.00	47.8	12.84	0.69	0.95	1.00	45.4	13.59	.70	.96	1.00
21.7°C	2645	60.4	8.95	0.42	0.57	0.71	54.2	10.72	0.41	0.57	0.73	47.5	12.83	0.39	0.57	0.75	45.3	13.58	.38	.58	.77
	3305	63.2	9.02	0.44	0.61	0.78	56.6	10.79	0.43	0.62	0.81	49.6	12.89	0.41	0.63	0.84	47.4	13.64	.41	.64	.86
	3965	65.1	9.07	0.46	0.65	0.85	58.4	10.84	0.44	0.67	0.88	51.3	12.94	0.45	0.69	0.93	48.9	13.69	.44	.70	.95

Entering Wet Bulb Temperature	Total Air Volume	Outdoor Air Temperature Entering Outdoor Coil																	
		48°C					50°C					51.7°C							
		Total Cool Cap.	Comp. Motor Input	Sensible To Total Ratio (S/T)			Total Cool Cap.	Comp. Motor Input	Sensible To Total Ratio (S/T)			Total Cool Cap.	Comp. Motor Input	Sensible To Total Ratio (S/T)					
				Dry Bulb					Dry Bulb					Dry Bulb					
L/s	kW	kW	24°C	27°C	29°C	kW	kW	24°C	27°C	29°C	kW	kW	24°C	27°C	29°C				
17.2°C	2645	37.5	14.03	0.82	1.00	1.00	36.0	14.66	0.83	1.00	1.00	34.8	15.21	0.84	1.00	1.00			
	3305	40.7	14.11	0.92	1.00	1.00	39.2	14.73	0.94	1.00	1.00	38.0	15.29	0.95	1.00	1.00			
	3965	43.2	14.18	0.99	1.00	1.00	41.6	14.80	0.99	1.00	1.00	40.2	15.35	0.99	1.00	1.00			
19.4°C	2645	40.2	14.10	0.58	0.79	0.98	38.4	14.72	0.58	0.81	0.99	37.0	15.26	0.58	0.82	0.99			
	3305	42.1	14.15	0.64	0.90	1.00	40.4	14.77	0.65	0.91	1.00	39.0	15.32	0.65	0.93	1.00			
	3965	43.7	14.19	0.71	0.98	1.00	42.0	14.81	0.72	0.98	1.00	40.5	15.36	0.73	0.99	1.00			
21.7°C	2645	43.6	14.19	0.38	0.58	0.77	41.9	14.81	0.37	0.58	0.78	40.3	15.34	0.37	0.58	0.79			
	3305	45.5	14.25	0.41	0.64	0.87	43.7	14.86	0.41	0.65	0.89	42.2	15.40	0.40	0.66	0.90			
	3965	47.0	14.28	0.45	0.71	0.96	45.1	14.90	0.44	0.72	0.97	43.5	15.45	0.44	0.73	0.98			

RATINGS - HIGH EFFICIENCY

NOTE - For Temperatures and Capacities not shown in tables, see bulletin - Cooling Unit Rating Table Correction Factor Data in Miscellaneous Engineering Data section.

70.3 kW - HIGH EFFICIENCY KCA240H4B (1ST STAGE) - CONSTANT AIR VOLUME

Entering Wet Bulb Temperature	Total Air Volume	Outdoor Air Temperature Entering Outdoor Coil																			
		18.3°C					23.9°C					29.4°C					35°C				
		Total Cool Cap.	Comp. Motor Input	Sensible To Total Ratio (S/T)			Total Cool Cap.	Comp. Motor Input	Sensible To Total Ratio (S/T)			Total Cool Cap.	Comp. Motor Input	Sensible To Total Ratio (S/T)			Total Cool Cap.	Comp. Motor Input	Sensible To Total Ratio (S/T)		
				Dry Bulb					Dry Bulb					Dry Bulb					Dry Bulb		
L/s	kW	kW	24°C	27°C	29°C	kW	kW	24°C	27°C	29°C	kW	kW	24°C	27°C	29°C	kW	kW	24°C	27°C	29°C	
17.2°C	3020	33.6	4.26	0.72	0.86	0.99	31.7	4.85	0.73	0.88	1.00	29.9	5.50	0.74	0.90	1.00	27.9	6.23	0.75	0.93	1.00
	3775	35.4	4.3	0.77	0.94	1.00	33.5	4.90	0.79	0.97	1.00	31.6	5.55	0.80	0.98	1.00	29.6	6.27	0.82	0.99	1.00
	4530	37.0	4.34	0.83	0.99	1.00	35.0	4.94	0.85	1.00	1.00	33.1	5.59	0.86	1.00	1.00	31.2	6.32	0.90	1.00	1.00
19.4°C	3020	35.9	4.31	0.57	0.70	0.83	34.0	4.91	0.57	0.70	0.84	32.0	5.56	0.57	0.72	0.86	29.9	6.28	0.57	0.73	0.89
	3775	37.6	4.35	0.60	0.75	0.91	35.5	4.95	0.61	0.77	0.93	33.4	5.60	0.61	0.78	0.96	31.2	6.32	0.61	0.80	0.98
	4530	38.9	4.39	0.64	0.81	0.98	36.7	4.98	0.63	0.82	0.99	34.5	5.63	0.65	0.84	1.00	32.2	6.36	0.66	0.87	1.00
21.7°C	3020	38.2	4.37	0.43	0.55	0.67	36.3	4.97	0.42	0.56	0.68	34.1	5.62	0.42	0.56	0.70	31.9	6.35	0.41	0.56	0.71
	3775	40.0	4.42	0.44	0.59	0.73	37.9	5.02	0.44	0.60	0.75	35.7	5.67	0.44	0.61	0.76	33.3	6.39	0.43	0.61	0.78
	4530	41.3	4.45	0.46	0.63	0.79	39.0	5.05	0.46	0.63	0.80	36.7	5.70	0.45	0.64	0.82	34.2	6.42	0.46	0.65	0.85

70.3 kW - HIGH EFFICIENCY KCA240H4B (2ND STAGE) - CONSTANT AIR VOLUME

Entering Wet Bulb Temperature	Total Air Volume	Outdoor Air Temperature Entering Outdoor Coil																			
		26.7°C					35°C					43.3°C					46°C				
		Total Cool Cap.	Comp. Motor Input	Sensible To Total Ratio (S/T)			Total Cool Cap.	Comp. Motor Input	Sensible To Total Ratio (S/T)			Total Cool Cap.	Comp. Motor Input	Sensible To Total Ratio (S/T)			Total Cool Cap.	Comp. Motor Input	Sensible To Total Ratio (S/T)		
				Dry Bulb					Dry Bulb					Dry Bulb					Dry Bulb		
L/s	kW	kW	24°C	27°C	29°C	kW	kW	24°C	27°C	29°C	kW	kW	24°C	27°C	29°C	kW	kW	24°C	27°C	29°C	
17.2°C	3020	62.5	10.37	0.77	0.94	1.00	56.6	12.48	0.79	0.97	1.00	50.5	15.05	0.82	0.99	1.00	48.4	15.98	.85	1.00	1.00
	3775	66.0	10.47	0.83	1.00	1.00	60.1	12.59	0.87	1.00	1.00	53.9	15.17	0.92	1.00	1.00	51.8	16.10	.94	1.00	1.00
	4530	69.3	10.57	0.90	1.00	1.00	63.2	12.69	0.94	1.00	1.00	56.5	15.26	0.98	1.00	1.00	54.4	16.19	.99	1.00	1.00
19.4°C	3020	66.6	10.48	0.59	0.74	0.90	60.2	12.59	0.60	0.77	0.94	53.3	15.15	0.61	0.80	0.98	51.0	16.07	.62	.83	.99
	3775	69.4	10.57	0.63	0.81	0.98	62.7	12.67	0.64	0.84	1.00	55.5	15.23	0.66	0.89	1.00	53.1	16.14	.68	.92	1.00
	4530	71.5	10.64	0.67	0.88	1.00	64.5	12.74	0.69	0.92	1.00	57.3	15.29	0.71	0.97	1.00	54.7	16.20	.74	.98	1.00
21.7°C	3020	71.0	10.62	0.43	0.58	0.72	64.4	12.73	0.42	0.59	0.75	57.1	15.28	0.41	0.60	0.78	54.7	16.20	.42	.61	.81
	3775	73.8	10.71	0.45	0.63	0.79	66.7	12.81	0.45	0.64	0.82	59.1	15.36	0.44	0.66	0.87	56.6	16.27	.44	.67	.90
	4530	75.7	10.77	0.47	0.66	0.86	68.4	12.87	0.47	0.69	0.90	60.6	15.41	0.47	0.71	0.96	58.0	16.33	.48	.74	.97
Entering Wet Bulb Temperature	Total Air Volume	Outdoor Air Temperature Entering Outdoor Coil																			
		48°C					50°C					51.7°C									
		Total Cool Cap.	Comp. Motor Input	Sensible To Total Ratio (S/T)			Total Cool Cap.	Comp. Motor Input	Sensible To Total Ratio (S/T)			Total Cool Cap.	Comp. Motor Input	Sensible To Total Ratio (S/T)							
				Dry Bulb					Dry Bulb					Dry Bulb							
L/s	kW	kW	24°C	27°C	29°C	kW	kW	24°C	27°C	29°C	kW	kW	24°C	27°C	29°C						
17.2°C	3020	46.9	16.74	0.84	1.00	1.00	45.3	17.52	0.86	1.00	1.00	44.0	18.21	0.88	1.00	1.00					
	3775	50.2	16.85	0.95	1.00	1.00	48.5	17.62	0.96	1.00	1.00	47.1	18.31	0.97	1.00	1.00					
	4530	52.7	16.94	1.00	1.00	1.00	50.9	17.72	1.00	1.00	1.00	49.4	18.39	1.00	1.00	1.00					
19.4°C	3020	49.1	16.82	0.61	0.82	0.99	47.4	17.59	0.62	0.84	1.00	45.9	18.27	0.62	0.85	1.00					
	3775	51.3	16.90	0.67	0.93	1.00	49.4	17.66	0.68	0.94	1.00	47.7	18.34	0.69	0.96	1.00					
	4530	53.0	16.95	0.74	0.99	1.00	51.1	17.72	0.75	0.99	1.00	49.5	18.41	0.76	1.00	1.00					
21.7°C	3020	52.8	16.94	0.41	0.61	0.80	50.8	17.71	0.41	0.61	0.81	49.2	18.39	0.41	0.62	0.83					
	3775	54.6	17.01	0.44	0.67	0.90	52.6	17.77	0.44	0.68	0.92	50.9	18.45	0.44	0.69	0.94					
	4530	56.0	17.07	0.47	0.74	0.98	53.9	17.83	0.47	0.75	0.99	52.2	18.50	0.47	0.76	0.99					

BLOWER DATA

BLOWER TABLE INCLUDES RESISTANCE FOR BASE UNIT ONLY WITH DRY INDOOR COIL & AIR FILTERS IN PLACE FOR ALL UNITS ADD:

- 1 - Wet indoor coil air resistance of selected unit.
- 2 - Any factory installed options air resistance (electric heat, economizer, etc.)
- 3 - Any field installed accessories air resistance (electric heat, duct resistance, diffuser, etc.)

Then determine from blower table blower motor output and drive required.

See page 32 for wet coil and option/accessory air resistance data.

See page 32 for factory installed drive kit specifications.

MINIMUM AIR VOLUME REQUIRED FOR USE WITH OPTIONAL ELECTRIC HEAT

All units require 2830 L/s (6000 cfm) minimum air with electric heat.

Air Volume		TOTAL STATIC PRESSURE - Pa (Inches Water Gauge)																	
		100 (0.40)			150 (0.60)			200 (0.80)			250 (1.00)			300 (1.20)			350 (1.40)		
L/s	cfm	rev/min	kW	BHP	rev/min	kW	BHP	rev/min	kW	BHP	rev/min	kW	BHP	rev/min	kW	BHP	rev/min	kW	BHP
2240	4750	575	0.82	1.10	660	1.08	1.45	740	1.34	1.80	810	1.60	2.15	870	1.86	2.50	930	2.13	2.85
2360	5000	585	0.93	1.25	670	1.19	1.60	750	1.45	1.95	815	1.72	2.30	880	2.01	2.70	940	2.27	3.05
2480	5250	595	1.01	1.35	680	1.27	1.70	755	1.57	2.10	825	1.86	2.50	890	2.16	2.90	945	2.42	3.25
2595	5500	605	1.08	1.45	690	1.38	1.85	765	1.68	2.25	835	1.98	2.65	895	2.27	3.05	955	2.57	3.45
2715	5750	615	1.19	1.60	700	1.49	2.00	775	1.83	2.45	840	2.13	2.85	905	2.42	3.25	960	2.72	3.65
2830	6000	630	1.30	1.75	710	1.60	2.15	785	1.94	2.60	850	2.27	3.05	910	2.57	3.45	970	2.91	3.90
2950	6250	640	1.42	1.90	720	1.75	2.35	795	2.09	2.80	860	2.42	3.25	920	2.76	3.70	975	3.09	4.15
3070	6500	650	1.53	2.05	730	1.86	2.50	805	2.24	3.00	870	2.57	3.45	930	2.95	3.95	985	3.28	4.40
3185	6750	665	1.64	2.20	745	2.01	2.70	815	2.39	3.20	880	2.76	3.70	940	3.13	4.20	995	3.47	4.65
3305	7000	675	1.75	2.35	755	2.16	2.90	825	2.54	3.40	890	2.95	3.95	950	3.32	4.45	1005	3.69	4.95
3420	7250	690	1.94	2.60	765	2.31	3.10	835	2.72	3.65	900	3.09	4.15	955	3.47	4.65	1015	3.91	5.25
3540	7500	700	2.05	2.75	775	2.46	3.30	845	2.87	3.85	910	3.32	4.45	965	3.69	4.95	1020	4.10	5.50
3660	7750	715	2.24	3.00	790	2.65	3.55	855	3.06	4.10	920	3.50	4.70	975	3.91	5.25	1030	4.33	5.80
3775	8000	725	2.39	3.20	800	2.83	3.80	865	3.24	4.35	930	3.69	4.95	985	4.10	5.50	1040	4.55	6.10
3895	8250	740	2.54	3.40	810	2.98	4.00	880	3.47	4.65	940	3.91	5.25	995	4.36	5.85	1050	4.81	6.45
4010	8500	750	2.72	3.65	825	3.21	4.30	890	3.65	4.90	950	4.14	5.55	1005	4.59	6.15	1060	5.07	6.80
4130	8750	765	2.91	3.90	835	3.39	4.55	900	3.88	5.20	960	4.36	5.85	1015	4.81	6.45	1070	5.33	7.15
4250	9000	780	3.13	4.20	850	3.62	4.85	910	4.10	5.50	970	4.59	6.15	1025	5.07	6.80	1080	5.59	7.50
4365	9250	790	3.32	4.45	860	3.84	5.15	925	4.36	5.85	985	4.88	6.55	1040	5.37	7.20	1090	5.85	7.85
4485	9500	805	3.54	4.75	875	4.06	5.45	935	4.59	6.15	995	5.15	6.90	1050	5.67	7.60	1100	6.15	8.25
4600	9750	820	3.77	5.05	885	4.29	5.75	950	4.88	6.55	1005	5.37	7.20	1060	5.93	7.95	1110	6.45	8.65
4720	10 000	835	4.03	5.40	900	4.59	6.15	960	5.11	6.85	1015	5.67	7.60	1070	6.23	8.35	1120	6.75	9.05
4835	10 250	845	4.21	5.65	910	4.81	6.45	970	5.37	7.20	1030	5.97	8.00	1080	6.52	8.75	1135	7.12	9.55
4955	10 500	860	4.47	6.00	925	5.11	6.85	985	5.70	7.65	1040	6.26	8.40	1095	6.86	9.20	1145	7.46	10.00
5075	10 750	875	4.77	6.40	940	5.41	7.25	1000	6.00	8.05	1055	6.60	8.85	1105	7.20	9.65	1155	7.79	10.45
5190	11 000	890	5.07	6.80	950	5.67	7.60	1010	6.30	8.45	1065	6.94	9.30	1115	7.49	10.05	1165	8.13	10.90

CONTINUED ON NEXT PAGE

BLOWER DATA

BLOWER TABLE INCLUDES RESISTANCE FOR BASE UNIT ONLY WITH DRY INDOOR COIL & AIR FILTERS IN PLACE FOR ALL UNITS ADD:

- 1 - Wet indoor coil air resistance of selected unit.
- 2 - Any factory installed options air resistance (electric heat, economizer, etc.)
- 3 - Any field installed accessories air resistance (electric heat, duct resistance, diffuser, etc.)

Then determine from blower table blower motor output and drive required.

See page 32 for wet coil and option/accessory air resistance data.

See page 32 for factory installed drive kit specifications.

MINIMUM AIR VOLUME REQUIRED FOR USE WITH OPTIONAL ELECTRIC HEAT

All units require 2830 L/s (6000 cfm) minimum air with electric heat.

Air Volume		TOTAL STATIC PRESSURE - Pa (Inches Water Gauge)																	
		400 (1.60)			450 (1.80)			500 (2.00)			550 (2.20)			600 (2.40)			650 (2.60)		
L/s	cfm	rev/min	kW	BHP	rev/min	kW	BHP	rev/min	kW	BHP	rev/min	kW	BHP	rev/min	kW	BHP	rev/min	kW	BHP
2240	4750	985	2.39	3.20	1040	2.65	3.55	1085	2.91	3.90	1135	3.17	4.25	1180	3.47	4.65	1225	3.73	5.00
2360	5000	995	2.54	3.40	1045	2.83	3.80	1095	3.09	4.15	1140	3.36	4.50	1185	3.65	4.90	1230	3.95	5.30
2480	5250	1000	2.72	3.65	1050	2.98	4.00	1100	3.28	4.40	1150	3.58	4.80	1195	3.88	5.20	1235	4.18	5.60
2595	5500	1010	2.87	3.85	1060	3.17	4.25	1110	3.50	4.70	1155	3.80	5.10	1200	4.10	5.50	1240	4.40	5.90
2715	5750	1015	3.06	4.10	1065	3.36	4.50	1115	3.69	4.95	1160	3.99	5.35	1205	4.33	5.80	1250	4.66	6.25
2830	6000	1025	3.24	4.35	1075	3.58	4.80	1120	3.88	5.20	1170	4.21	5.65	1215	4.55	6.10	1255	4.88	6.55
2950	6250	1030	3.43	4.60	1080	3.77	5.05	1130	4.10	5.50	1175	4.44	5.95	1220	4.81	6.45	1265	5.15	6.90
3070	6500	1040	3.62	4.85	1090	3.99	5.35	1140	4.36	5.85	1185	4.70	6.30	1225	5.03	6.75	1270	5.41	7.25
3185	6750	1045	3.80	5.10	1095	4.18	5.60	1145	4.55	6.10	1190	4.92	6.60	1235	5.29	7.10	1275	5.67	7.60
3305	7000	1055	4.03	5.40	1105	4.44	5.95	1155	4.81	6.45	1200	5.18	6.95	1240	5.56	7.45	1285	5.97	8.00
3420	7250	1065	4.29	5.75	1115	4.66	6.25	1160	5.03	6.75	1205	5.44	7.30	1250	5.85	7.85	1290	6.23	8.35
3540	7500	1075	4.51	6.05	1125	4.92	6.60	1170	5.33	7.15	1215	5.70	7.65	1260	6.15	8.25	1300	6.52	8.75
3660	7750	1080	4.74	6.35	1130	5.15	6.90	1180	5.59	7.50	1225	6.00	8.05	1265	6.41	8.60	1305	6.82	9.15
3775	8000	1090	5.00	6.70	1140	5.41	7.25	1185	5.85	7.85	1230	6.26	8.40	1275	6.71	9.00	1315	7.16	9.60
3895	8250	1100	5.26	7.05	1150	5.70	7.65	1195	6.15	8.25	1240	6.60	8.85	1280	7.01	9.40	1325	7.49	10.05
4010	8500	1110	5.52	7.40	1160	6.00	8.05	1205	6.45	8.65	1250	6.90	9.25	1290	7.35	9.85	1330	7.79	10.45
4130	8750	1120	5.78	7.75	1165	6.23	8.35	1215	6.75	9.05	1255	7.20	9.65	1300	7.68	10.30	1340	8.13	10.90
4250	9000	1130	6.08	8.15	1175	6.52	8.75	1220	7.01	9.40	1265	7.53	10.10	1310	8.05	10.80	1350	8.50	11.40
4365	9250	1140	6.38	8.55	1185	6.86	9.20	1230	7.35	9.85	1275	7.87	10.55	1315	8.35	11.20	---	---	---
4485	9500	1150	6.67	8.95	1195	7.16	9.60	1240	7.68	10.30	1285	8.24	11.05	---	---	---	---	---	---
4600	9750	1160	7.01	9.40	1205	7.49	10.05	1250	8.05	10.80	1295	8.58	11.50	---	---	---	---	---	---
4720	10 000	1170	7.31	9.80	1215	7.83	10.50	1260	8.39	11.25	---	---	---	---	---	---	---	---	---
4835	10 250	1180	7.64	10.25	1225	8.20	11.00	---	---	---	---	---	---	---	---	---	---	---	---
4955	10 500	1190	7.98	10.70	1235	8.54	11.45	---	---	---	---	---	---	---	---	---	---	---	---
5075	10 750	1200	8.35	11.20	---	---	---	---	---	---	---	---	---	---	---	---	---	---	---
5190	11 000	---	---	---	---	---	---	---	---	---	---	---	---	---	---	---	---	---	---

BLOWER DATA

FACTORY INSTALLED BELT DRIVE KIT SPECIFICATIONS

Motor Efficiency	Nominal kW	Nominal hp	Maximum kW	Maximum hp	Drive Kit Number	Rev/Min Range	
						CAV	MSAV
Standard	1.5	2	1.7	2.3	1	446 - 604	535-725
Standard	1.5	2	1.7	2.3	2	592 - 804	710-965
Standard	2.2	3	2.6	3.5	3	571 - 721	685-865
Standard	2.2	3	2.6	3.5	4	708 - 871	850-1045
Standard	3.7	5	4.3	5.8	3	571 - 721	685-865
Standard	3.7	5	4.3	5.8	4	708 - 871	850-1045
Standard	3.7	5	4.3	5.8	5	788 - 988	945-1185
Standard	5.6	8	6.4	8.6	6	708 - 871	850-1045
Standard	5.6	8	6.4	8.6	7	788 - 988	945-1185
Standard	5.6	8	6.4	8.6	8	871 - 1071	1045-1285
Standard	7.5	10	8.6	11.5	7	788 - 988	945-1185
Standard	7.5	10	8.6	11.5	10	871 - 1071	1045-1285
Standard	7.5	10	8.6	11.5	11	946 - 1138	1135-1365

NOTE - Using total air volume and system static pressure requirements determine from blower performance tables rev/min and motor output required. Maximum usable output of motors furnished are shown. If motors of comparable output are used, be sure to keep within the service factor limitations outlined on the motor nameplate.

NOTE - Units equipped with MSAV® (Multi-Stage Air Volume) option are limited to a motor service factor of 1.0.

FACTORY INSTALLED OPTIONS/FIELD INSTALLED ACCESSORY AIR RESISTANCE

Air Volume		Wet Indoor Coil				Electric Heat Economizer				Filters				Horizontal Roof Curb			
		156H 180H 180S		210H 210S 240H 240S 300S						MERV 8		MERV 13		156H 180S 240H 240S		300S	
L/s	cfm	Pa	in. w.g.	Pa	in. w.g.	Pa	in. w.g.	Pa	in. w.g.	Pa	in. w.g.	Pa	in. w.g.	Pa	in. w.g.	Pa	in. w.g.
1888	4000	5	0.02	10	0.04	---	---	---	---	3	0.01	11	0.04	15	0.06	5	0.02
2006	4250	5	0.02	10	0.04	---	---	---	---	3	0.01	12	0.05	17	0.07	5	0.02
2124	4500	5	0.02	12	0.05	---	---	---	---	4	0.01	12	0.05	17	0.07	5	0.02
2242	4750	5	0.02	12	0.05	---	---	---	---	4	0.02	13	0.05	20	0.08	7	0.03
2360	5000	5	0.02	12	0.05	---	---	---	---	5	0.02	14	0.06	20	0.08	7	0.03
2477	5250	5	0.02	15	0.06	---	---	---	---	5	0.02	15	0.06	22	0.09	10	0.04
2595	5500	5	0.02	17	0.07	---	---	---	---	6	0.02	15	0.06	25	0.10	10	0.04
2713	5750	7	0.03	17	0.07	---	---	---	---	6	0.02	16	0.07	27	0.11	12	0.05
2831	6000	7	0.03	20	0.08	2	0.01	---	---	7	0.03	17	0.07	27	0.11	15	0.06
2949	6250	7	0.03	20	0.08	2	0.01	2	0.01	7	0.03	18	0.07	30	0.12	17	0.07
3067	6500	7	0.03	22	0.09	2	0.01	5	0.02	8	0.03	19	0.08	32	0.13	20	0.08
3185	6750	10	0.04	25	0.10	2	0.01	7	0.03	8	0.03	20	0.08	35	0.14	20	0.08
3303	7000	10	0.04	25	0.10	2	0.01	10	0.04	9	0.04	20	0.08	37	0.15	22	0.09
3421	7250	10	0.04	27	0.11	2	0.01	12	0.05	10	0.04	21	0.09	40	0.16	25	0.10
3539	7500	12	0.05	30	0.12	2	0.01	15	0.06	10	0.04	22	0.09	42	0.17	27	0.11
3775	8000	12	0.05	32	0.13	5	0.02	22	0.09	12	0.05	24	0.10	47	0.19	32	0.13
4011	8500	15	0.06	37	0.15	5	0.02	27	0.11	13	0.05	25	0.10	52	0.21	37	0.15
4247	9000	17	0.07	40	0.16	10	0.04	35	0.14	15	0.06	27	0.11	60	0.24	42	0.17
4483	9500	20	0.08	45	0.18	12	0.05	40	0.16	17	0.07	29	0.12	65	0.26	47	0.19
4719	10 000	20	0.08	50	0.20	15	0.06	47	0.19	19	0.07	31	0.12	72	0.29	52	0.21
4955	10 500	22	0.09	55	0.22	22	0.09	55	0.22	20	0.08	33	0.13	77	0.31	60	0.24
5191	11 000	27	0.11	60	0.24	27	0.11	62	0.25	22	0.09	35	0.14	85	0.34	67	0.27

BLOWER DATA

POWER EXHAUST FAN PERFORMANCE

Return Air System Static Pressure		Air Volume Exhausted	
Pa	in. w.g.	L/s	cfm
0	0.00	3395	7195
12	0.05	3230	6845
25	0.10	3040	6440
37	0.15	2795	5925
50	0.20	2545	5395
62	0.25	2275	4820
75	0.30	1990	4215
87	0.35	1690	3580
100	0.40	1380	2925
112	0.45	1055	2235
125	0.50	725	1535

CEILING DIFFUSER AIR RESISTANCE

Air Volume		Step-Down Diffuser												Flush Diffuser			
		RTD11-185S						RTD11-275S						FD11-185S		FD11-275	
		2 Ends Open		1 Side/2 Ends Open		All Ends & Sides Open		2 Ends Open		1 Side/2 Ends Open		All Ends & Sides Open		Pa	in. w.g.	Pa	in. w.g.
L/s	cfm	Pa	in. w.g.	Pa	in. w.g.	Pa	in. w.g.	Pa	in. w.g.	Pa	in. w.g.	Pa	in. w.g.	Pa	in. w.g.	Pa	in. w.g.
2360	5000	127	0.51	109	0.44	97	0.39	---	---	---	---	---	---	67	0.27	---	---
2455	5200	139	0.56	119	0.48	104	0.42	---	---	---	---	---	---	75	0.30	---	---
2550	5400	152	0.61	129	0.52	112	0.45	---	---	---	---	---	---	82	0.33	---	---
2645	5600	164	0.66	139	0.56	119	0.48	---	---	---	---	---	---	90	0.36	---	---
2735	5800	177	0.71	147	0.59	127	0.51	---	---	---	---	---	---	97	0.39	---	---
2830	6000	189	0.76	157	0.63	137	0.55	90	0.36	77	0.31	67	0.27	104	0.42	72	0.29
2925	6200	199	0.80	169	0.68	147	0.59	---	---	---	---	---	---	114	0.46	---	---
3020	6400	214	0.86	179	0.72	157	0.63	---	---	---	---	---	---	124	0.50	---	---
3065	6500	---	---	---	---	---	---	104	0.42	90	0.36	77	0.31	---	---	85	0.34
3115	6600	229	0.92	191	0.77	167	0.67	---	---	---	---	---	---	134	0.54	---	---
3210	6800	246	0.99	206	0.83	179	0.72	---	---	---	---	---	---	144	0.58	---	---
3305	7000	256	1.03	216	0.87	189	0.76	122	0.49	102	0.41	90	0.36	154	0.62	99	0.40
3400	7200	271	1.09	229	0.92	199	0.80	---	---	---	---	---	---	164	0.66	---	---
3490	7400	286	1.15	241	0.97	209	0.84	---	---	---	---	---	---	174	0.70	---	---
3540	7500	---	---	---	---	---	---	127	0.51	114	0.46	102	0.41	---	---	112	0.45
3585	7600	298	1.20	254	1.02	219	0.88	---	---	---	---	---	---	184	0.74	---	---
3775	8000	---	---	---	---	---	---	147	0.59	122	0.49	107	0.43	---	---	124	0.50
4010	8500	---	---	---	---	---	---	172	0.69	144	0.58	124	0.50	---	---	142	0.57
4245	9000	---	---	---	---	---	---	196	0.79	167	0.67	144	0.58	---	---	164	0.66
4485	9500	---	---	---	---	---	---	221	0.89	186	0.75	162	0.65	---	---	184	0.74
4720	10 000	---	---	---	---	---	---	249	1.00	209	0.84	182	0.73	---	---	201	0.81
4955	10 500	---	---	---	---	---	---	274	1.10	229	0.92	199	0.80	---	---	221	0.89
5190	11 000	---	---	---	---	---	---	301	1.21	251	1.01	219	0.88	---	---	239	0.96

CEILING DIFFUSER AIR THROW DATA

Model No.	Air Volume		1 Effective Throw Range				Model No.	Air Volume		1 Effective Throw Range			
	L/s	cfm	RTD11-185S Step-Down		FD11-185S Flush			L/s	cfm	RTD11-185S Step-Down		FD11-185S Flush	
			m	ft.	m	ft.				m	ft.	m	ft.
156 180	2645	5600	12 - 15	39 - 49	9 - 11	28 - 37	210 240 300	3400	7200	10 - 12	33 - 38	8 - 11	26 - 35
	2735	5800	13 - 16	42 - 51	9 - 12	29 - 38		3490	7400	11 - 12	35 - 40	9 - 11	28 - 37
	2830	6000	13 - 16	44 - 54	12 - 15	40 - 50		3585	7600	11 - 12	36 - 41	9 - 11	29 - 38
	2925	6200	14 - 17	45 - 55	13 - 16	42 - 51		3680	7800	12 - 13	38 - 43	12 - 15	40 - 50
	3020	6400	14 - 17	46 - 55	13 - 16	43 - 52		3775	8000	12 - 13	39 - 44	13 - 16	42 - 51
	3115	6600	14 - 17	47 - 56	14 - 17	45 - 56		3870	8200	12 - 14	41 - 46	13 - 16	43 - 52
							3965	8400	13 - 15	43 - 49	13 - 16	44 - 54	
							4060	8600	13 - 15	44 - 50	14 - 17	46 - 57	
							4155	8800	14 - 17	47 - 55	15 - 18	48 - 59	

¹ Throw is the horizontal or vertical distance an airstream travels on leaving the outlet or diffuser before the maximum velocity is reduced to 15 m (50 ft.) per minute. Four sides open.

ELECTRICAL/ELECTRIC HEAT DATA - STANDARD EFFICIENCY

		KCB180S4			KCB210S4			KCB240S4			KCB300S4		
¹ Voltage - 50Hz 3 Phase		380/420V			380/420V			380/420V			380/420V		
Compressor 1	Rated Load Amps	6.3			8			10.6			8		
	Locked Rotor Amps	55			67.1			74			67.1		
Compressor 2	Rated Load Amps	6.3			8			10.6			8		
	Locked Rotor Amps	55			67.1			74			67.1		
Compressor 3	Rated Load Amps	6.3			8			12.2			10.6		
	Locked Rotor Amps	55			67.1			101			74		
Compressor 4	Rated Load Amps	---			---			---			10.6		
	Locked Rotor Amps	---			---			---			74		
Outdoor Fan Motors	Number of motors	3			3			4			6		
	Full Load Amps	1.3			1.3			1.3			1.3		
	(total)	(3.9)			(3.9)			(5.2)			(7.8)		
Power Exhaust With (2) 0.25 kW	Full Load Amps	1.3			1.3			1.3			1.3		
	(total)	(2.6)			(2.6)			(2.6)			(2.6)		
Indoor Blower Motor	kW	2.2	3.7	5.6	2.2	3.7	5.6	3.7	5.6	7.5	3.7	5.6	7.5
	Full Load Amps	5.3	8.2	11.7	5.3	8.2	11.7	8.2	11.7	16.3	8.2	11.7	16.3
¹ Maximum Overcurrent Protection	Unit Only	35	40	45	40	45	50	60	60	70	60	70	80
	With (2) 0.25 kW Power Exhaust	35	40	50	45	45	50	60	60	70	60	70	80
² Minimum Circuit Ampacity	Unit Only	30	34	38	36	39	43	50	54	59	56	60	66
	With (2) 0.25 kW Power Exhaust	33	36	41	38	41	46	53	56	62	59	63	68

ELECTRIC HEAT DATA

			Electric Heat Voltage											
			420	420	420	420	420	420	420	420	420	420	420	420
¹ Maximum Overcurrent Protection	Unit+	11.5 kW	35	40	45	40	45	50	60	60	70	60	70	80
	³ Electric Heat	23 kW	50	50	60	50	50	60	60	60	70	60	70	80
		34.5 kW	70	70	80	70	70	80	70	80	80	70	80	80
		45.9 kW	70	80	80	70	80	80	80	80	90	80	80	90
² Minimum Circuit Ampacity	Unit+	11.5 kW	30	34	38	36	39	43	50	54	59	56	60	66
	³ Electric Heat	23 kW	47	50	55	47	50	55	50	55	60	56	60	66
		34.5 kW	66	70	74	66	70	74	70	74	80	70	74	80
		45.9 kW	70	74	78	70	74	78	74	78	84	74	78	84
¹ Maximum Overcurrent Protection	Unit+	11.5 kW	35	40	50	45	45	50	60	60	70	60	70	80
	³ Electric Heat	23 kW	50	60	60	50	60	60	60	60	70	60	70	80
	and (2) 0.25 kW	34.5 kW	70	80	80	70	80	80	80	80	90	80	80	90
	Power Exhaust	45.9 kW	80	80	90	80	80	90	80	90	90	80	90	90
² Minimum Circuit Ampacity	Unit+	11.5 kW	33	36	41	38	41	46	53	56	62	59	63	68
	³ Electric Heat	23 kW	50	53	58	50	53	58	53	58	64	59	63	68
	and (2) 0.25 kW	34.5 kW	70	73	78	70	73	78	73	78	83	73	78	83
	Power Exhaust	45.9 kW	74	77	82	74	77	82	77	82	87	77	82	87

NOTE - Extremes of operating range are plus and minus 10% of line voltage.

¹ Heating / Air Conditioning / Refrigeration (HACR) type breaker or fuse.

² Refer to local codes to determine wire, fuse and disconnect size requirements.

³ Nominal kW based on 420V-3ph-50Hz.

ELECTRICAL/ELECTRIC HEAT DATA - HIGH EFFICIENCY

		KCA156H4			KCA180H4			KCA210H4			KCA240H4		
¹ Voltage - 50Hz 3 Phase		380/420V			380/420V			380/420V			380/420V		
Compressor 1	Rated Load Amps	6.3			6.3			7.8			6.3		
	Locked Rotor Amps	55			55			51.5			55		
Compressor 2	Rated Load Amps	6.3			6.3			7.8			6.3		
	Locked Rotor Amps	55			55			51.5			55		
Compressor 3	Rated Load Amps	6.3			6.3			8			6.3		
	Locked Rotor Amps	55			55			67.1			55		
Compressor 4	Rated Load Amps	---			---			---			6.3		
	Locked Rotor Amps	---			---			---			55		
Outdoor Fan Motors	Number of motors	3			4			6			6		
	Full Load Amps (total)	1.3 (3.9)			1.3 (5.2)			1.3 (7.8)			1.3 (7.8)		
Power Exhaust With (2) 0.25 kW	Full Load Amps	1.3			1.3			1.3			1.3		
	(total)	(2.6)			(2.6)			(2.6)			(2.6)		
Indoor Blower Motor	kW	1.5	2.2	3.7	2.2	3.7	5.6	2.2	3.7	5.6	3.7	5.6	7.5
	Full Load Amps	3.6	5.3	8.2	5.3	8.2	11.7	5.3	8.2	11.7	8.2	11.7	16.3
² Maximum Overcurrent Protection	Unit Only	30	35	40	35	40	50	45	45	50	50	50	60
	With (2) 0.25 kW Power Exhaust	35	35	40	35	45	50	45	50	60	50	60	70
³ Minimum Circuit Ampacity	Unit Only	28	30	34	31	35	39	39	42	47	44	48	54
	With (2) 0.25 kW Power Exhaust	31	33	36	34	37	42	42	45	49	46	51	56

ELECTRIC HEAT DATA

		Electric Heat Voltage											
		420	420	420	420	420	420	420	420	420	420	420	420
² Maximum Overcurrent Protection	Unit+ 11.5 kW	30	35	40	35	40	50	45	45	50	50	50	60
	⁴ Electric Heat 23 kW	45	50	50	50	50	60	50	50	60	50	60	60
	34.5 kW	70	70	70	70	70	80	70	70	80	70	80	80
	45.9 kW	70	70	80	70	80	80	70	80	80	80	80	90
³ Minimum Circuit Ampacity	Unit+ 11.5 kW	28	30	34	31	35	39	39	42	47	44	48	54
	⁴ Electric Heat 23 kW	44	47	50	47	50	55	47	50	55	50	55	60
	34.5 kW	64	66	70	66	70	74	66	70	74	70	74	80
	45.9 kW	68	70	74	70	74	78	70	74	78	74	78	84
² Maximum Overcurrent Protection	Unit+ 11.5 kW	35	35	40	35	45	50	45	50	60	50	60	70
	⁴ Electric Heat 23 kW	50	50	60	50	60	60	50	60	60	60	60	70
	and (2) 0.25 kW 34.5 kW	70	70	80	70	80	80	70	80	80	80	80	90
	Power Exhaust 45.9 kW	80	80	80	80	80	90	80	80	90	80	90	90
³ Minimum Circuit Ampacity	Unit+ 11.5 kW	31	33	36	34	37	42	42	45	49	46	51	56
	⁴ Electric Heat 23 kW	48	50	53	50	53	58	50	53	58	53	58	64
	and (2) 0.25 kW 34.5 kW	67	70	73	70	73	78	70	73	78	73	78	83
	Power Exhaust 45.9 kW	71	74	77	74	77	82	74	77	82	77	82	87

¹ Extremes of operating range are plus and minus 10% of line voltage.

² Heating / Air Conditioning / Refrigeration (HACR) type breaker or fuse.

³ Refer to local codes to determine wire, fuse and disconnect size requirements.

⁴ Nominal kW based on 420V-3ph-50Hz.

ELECTRIC HEAT CAPACITIES

Volts Input	11.5 kW			23 kW			34.5 kW			45.9 kW		
	kW Input	Btuh Output	No. of Stages	kW Input	Btuh Output	No. of Stages	kW Input	Btuh Output	No. of Stages	kW Input	Btuh Output	No. of Stages
380	9.4	32 100	1	18.8	64 200	1	28.2	96 300	2	37.6	128 400	2
400	10.4	35 600	1	20.8	71 100	1	31.2	106 700	2	41.6	142 200	2
420	11.5	39 200	1	23.0	78 400	1	34.4	117 600	2	45.9	156 800	2

UNIT CLEARANCES

Unit With Economizer

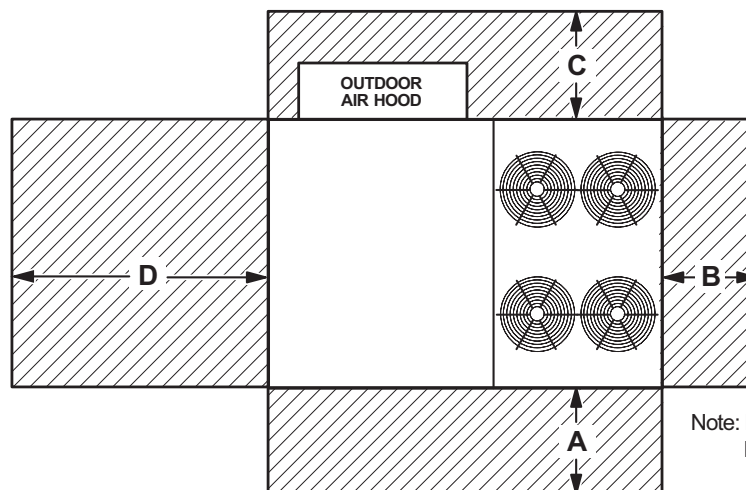

Note: Models with four outdoor fans shown.
Dimension clearances are for all sizes.

¹ Unit Clearance	A		B		C		D		Top Clearance
	mm	in.	mm	in.	mm	in.	mm	in.	
Service Clearance	1524	60	914	36	914	36	1676	66	Unobstructed
Minimum Operation Clearance	1143	45	914	36	914	36	1041	41	

NOTE - Entire perimeter of unit base requires support when elevated above the mounting surface.

¹ Service Clearance - Required for removal of serviceable parts.

Minimum Operation Clearance - Required clearance for proper unit operation.

OUTDOOR SOUND DATA

Unit Model Number	Octave Band Linear Sound Power Levels dB, re 10 ⁻¹² Watts - Center Frequency - Hz							¹ Sound Rating Number (SRN) (dBA)
	125	250	500	1000	2000	4000	8000	
156H, 180S, 210S	71	78	81	81	76	71	63	86
180H, 240S	80	83	87	88	84	80	71	93
210H, 240H, 300S	79	84	88	89	85	82	73	94

Note - The octave sound power data does not include tonal corrections.

¹ Sound Rating Number according to ARI Standard 370-2001 (includes pure tone penalty). "SRN" is the overall A-Weighted Sound Power Level, (LWA), dB (100 Hz to 10,000 Hz).

WEIGHT DATA

Model Number	Outdoor Coil	Net		Shipping		Outdoor	Net		Shipping	
		kg	lbs.	kg	lbs.		kg	lbs.	kg	lbs.
156H Base Unit	Environ™	810	1785	900	1985	---	---	---	---	---
156H Max. Unit	Environ™	937	2065	1027	2265	---	---	---	---	---
180H Base Unit	Environ™	891	1965	982	2165	---	---	---	---	---
180H Max. Unit	Environ™	1018	2245	1109	2445	---	---	---	---	---
210H Base Unit	Environ™	948	2090	1039	2290	---	---	---	---	---
210H Max. Unit	Environ™	1080	2380	1170	2580	---	---	---	---	---
240H Base Unit	Environ™	987	2175	1077	2375	---	---	---	---	---
240H Max. Unit	Environ™	1118	2465	1209	2665	---	---	---	---	---
180S Base Unit	Environ™	773	1705	864	1905	Fin/Tube	802	1770	894	1970
180S Max. Unit	Environ™	919	2025	1009	2225	Fin/Tube	925	2040	1016	2240
210S Base Unit	Environ™	823	1815	914	2015	Fin/Tube	852	1880	944	2080
210S Max. Unit	Environ™	973	2145	1064	2345	Fin/Tube	979	2160	1071	2360
240S Base Unit	Environ™	921	2030	1012	2230	Fin/Tube	962	2120	1053	2320
240S Max. Unit	Environ™	1070	2360	1161	2560	Fin/Tube	1087	2400	1179	2600
300S Base Unit	Environ™	1043	2300	1134	2500	Fin/Tube	1073	2365	1163	2565
300S Max. Unit	Environ™	1175	2590	1266	2790	Fin/Tube	1181	2605	1272	2805

NOTE - Max. Unit is the unit with ALL INTERNAL OPTIONS Installed. (Economizer, Standard Static Power Exhaust Fans, Controls, etc.). Does not include accessories EXTERNAL to unit.

OPTIONS / ACCESSORIES

Description	Shipping Weight		
	kg	lbs.	
ECONOMIZER / OUTDOOR AIR / EXHAUST			
Economizer			
Economizer Dampers	46	102	
Barometric Relief Dampers (downflow)	14	30	
Barometric Relief Dampers (horizontal)	9	20	
Outdoor Air Damper Hood (downflow)	29	65	
Outdoor Air Dampers			
Outdoor Air Damper Section (downflow) - Automatic (including Hood)	39	18	
Outdoor Air Damper Section (downflow) - Manual (including Hood)	22	10	
Power Exhaust	28	62	
ELECTRIC HEAT			
11.3 kW	27	59	
23 kW	27	59	
34.5 kW	34	76	
45.9 kW	34	76	
MSAV® (MULTI-STAGE AIR VOLUME) SUPPLY AIR BLOWER OPTION			
Variable Frequency Drive (VFD) and associated components	5	10	
ROOF CURBS			
Hybrid Roof Curbs, Downflow			
203 mm height	34	75	
356 mm height	48	105	
457 mm height	57	125	
610 mm height	70	155	
Horizontal Roof Curbs, Standard			
660 mm height	231	470	
940 mm height	229	505	
762 mm height	261	575	
1041 mm height	277	610	
Adjustable Pitch Curb, Downflow			
356 mm height	32	191	
CEILING DIFFUSERS			
Step-Down	RTD11-185S	168	76
	RTD11-275S	238	108
Flush	FD11-185S	168	76
	FD11-275S	238	108
Transitions	C1DIFF33C-1	36	80
	C1DIFF34C-1	34	75
PACKAGING			
LTL Packaging (less than truck load)	141	310	

DIMENSIONS - UNIT

KCA156H, KCB180S, KCB210S

CORNER WEIGHTS

CENTER OF GRAVITY

Model No.	AA		BB		CC		DD		EE		FF	
	kg	lbs.	kg	lbs.	kg	lbs.	kg	lbs.	mm	in.	mm	in.
KCA156H Base Unit (Environ™ Coil)	195	428	157	346	207	456	252	554	1232	48 1/2	1003	39 1/2
KCA156H Max. Unit (Environ™ Coil)	244	538	195	429	222	489	277	609	1219	48	1086	43
KCB180S Base Unit (Environ™ Coil)	176	389	152	335	206	455	239	528	1270	50	991	39
KCB180S Max. Unit (Environ™ Coil)	229	504	186	411	226	499	278	612	1219	48	1041	41
KCB180S Base Unit (Fin/Tube Coil)	176	392	166	365	219	485	240	531	1276	50 1/4	1010	39 3/4
KCB180S Max. Unit (Fin/Tube Coil)	224	495	195	428	234	514	272	598	1257	49 1/2	1086	42 3/4
KCB210S Base Unit (Environ™ Coil)	194	427	162	358	213	470	254	561	1245	49	991	39
KCB210S Max. Unit (Environ™ Coil)	249	549	197	435	233	514	294	648	1219	48	1067	42
KCB210S Base Unit (Fin/Tube Coil)	194	430	176	388	226	500	255	564	1276	50 1/4	1010	39 3/4
KCB210S Max. Unit (Fin/Tube Coil)	244	539	206	453	241	530	288	634	1257	49 1/2	1086	42 3/4

Base Unit - The unit with NO INTERNAL OPTIONS.

Max. Unit - The unit with ALL INTERNAL OPTIONS Installed. (Economizer, Standard Static Power Exhaust Fans, Controls, etc.). Does not include accessories external to unit.

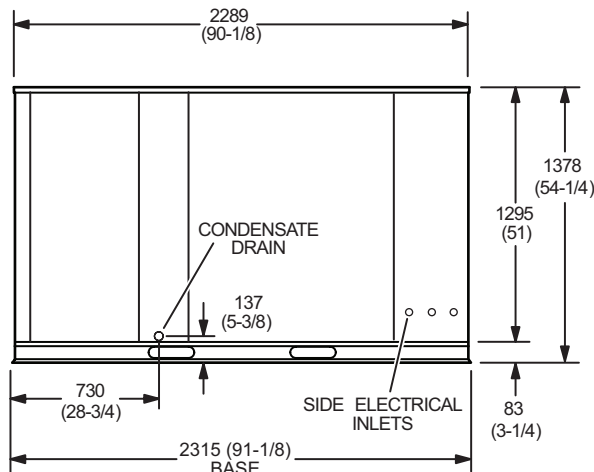
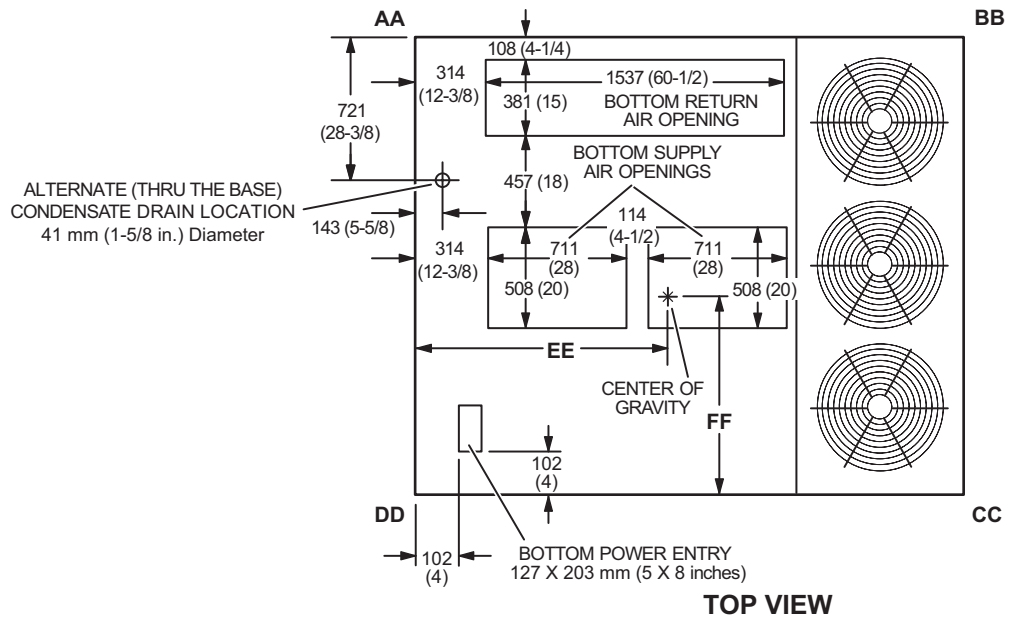

END VIEW

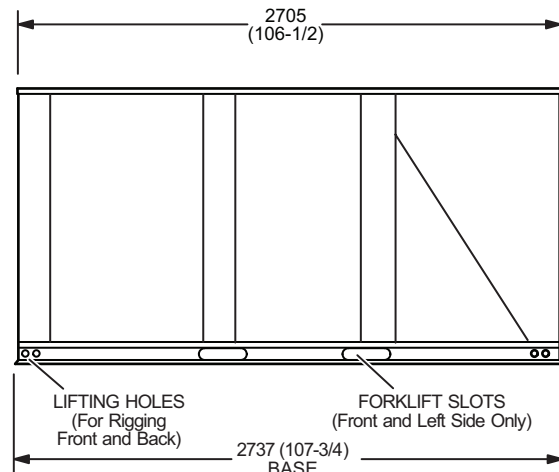

SIDE VIEW

DIMENSIONS - UNIT

KCA180H, KCB240S

CORNER WEIGHTS

CENTER OF GRAVITY

Model No.	AA		BB		CC		DD		EE		FF	
	kg	lbs.	kg	lbs.	kg	lbs.	kg	lbs.	mm	in.	mm	in.
KCA180H Base Unit (Environ™ Coil)	201	441	183	403	247	543	262	577	1321	52	997	391/4
KCA180H Max. Unit (Environ™ Coil)	248	545	221	485	262	577	290	638	1295	51	1067	42
KCB240S Base Unit (Environ™ Coil)	196	432	178	392	260	573	287	632	1295	51	940	37
KCB240S Max. Unit (Environ™ Coil)	245	540	216	476	285	629	324	714	1283	50 1/2	991	39
KCB240S Base Unit (Fin/Tube Coil)	195	432	202	445	283	626	287	632	1391	54 3/4	1003	39 1/2
KCB240S Max. Unit (Fin/Tube Coil)	240	528	235	517	302	666	317	698	1359	53 1/2	1067	42

Base Unit - The unit with NO INTERNAL OPTIONS.

Max. Unit - The unit with ALL INTERNAL OPTIONS Installed. (Economizer, Standard Static Power Exhaust Fans, Controls, etc.). Does not include accessories external to unit.

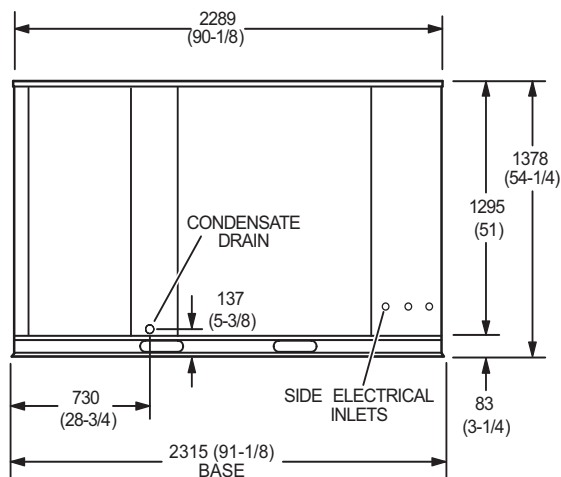
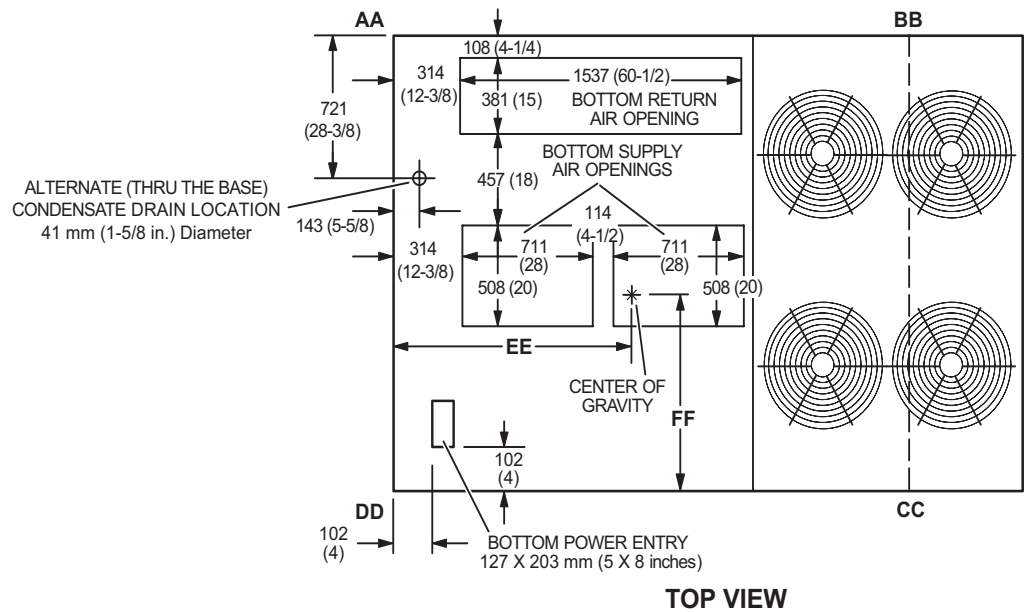

END VIEW

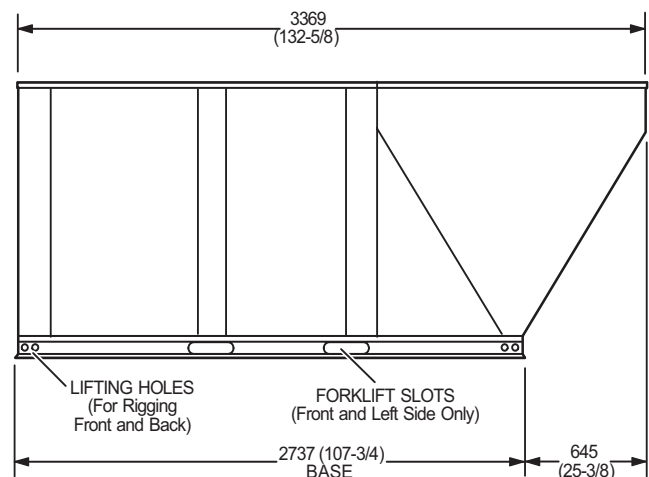

SIDE VIEW

OUTDOOR AIR HOOD DETAIL

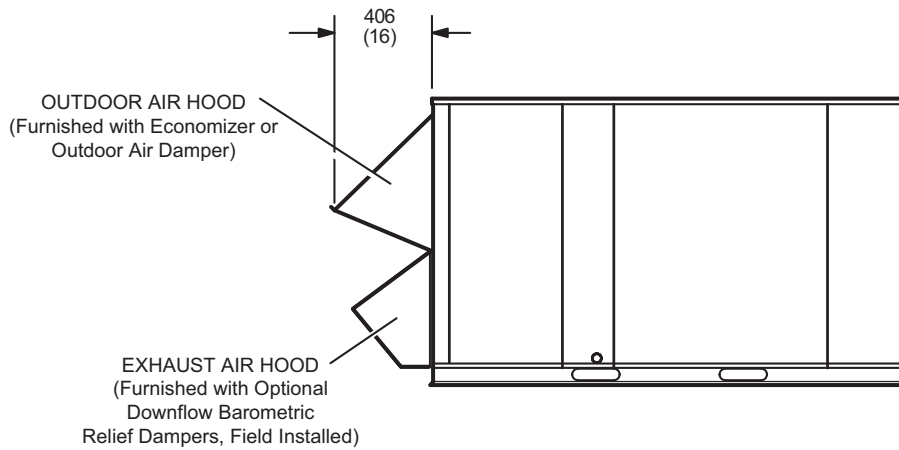

OPTIONAL HORIZONTAL BAROMETRIC RELIEF DAMPERS WITH HOOD

(Field installed in horizontal return air duct adjacent to unit)

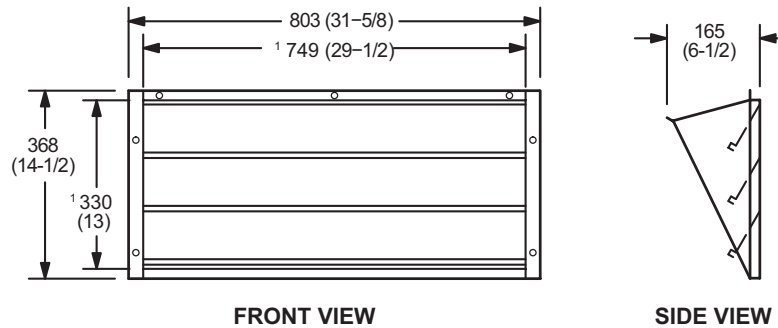

NOTE - Two furnished per order number.
¹ NOTE - Opening size required in return air duct.

DIMENSIONS - ACCESSORIES

HYBRID ROOF CURBS - DOUBLE DUCT OPENING

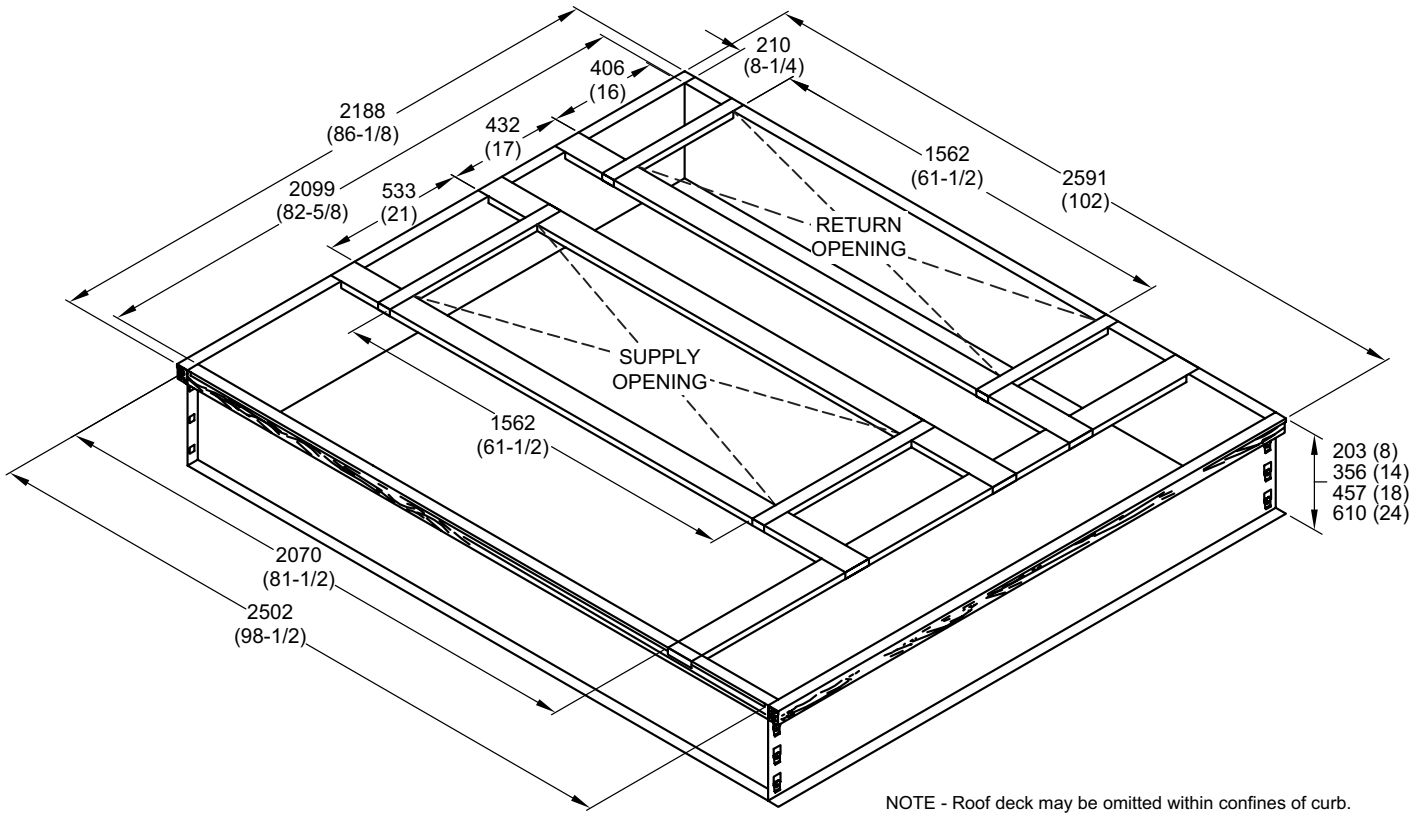

TYPICAL FLASHING DETAIL FOR ROOF CURB

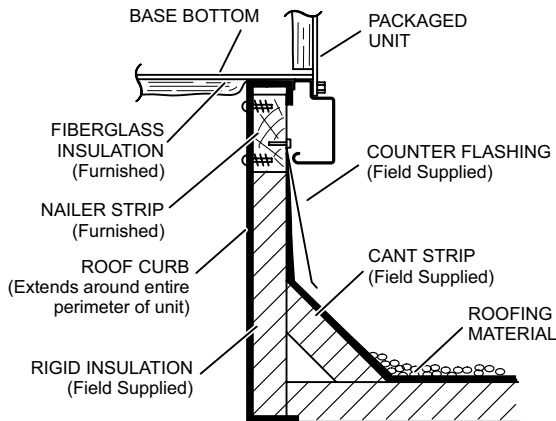

DETAIL ROOF CURB

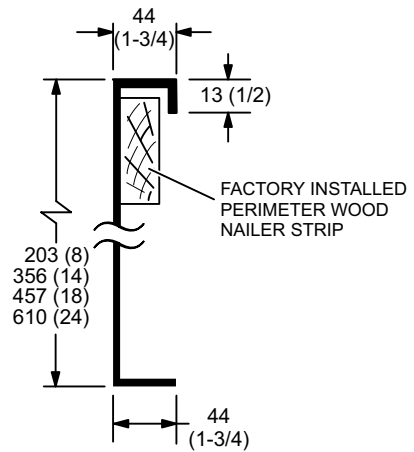

DIMENSIONS - ACCESSORIES

ROOF CURBS WITH SUPPLY & RETURN AIR TRANSITIONS FOR CEILING DIFFUSERS

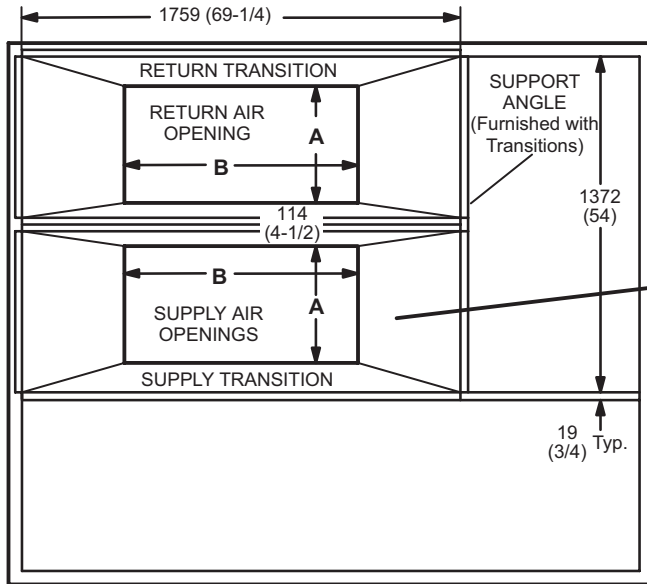

TOP VIEW

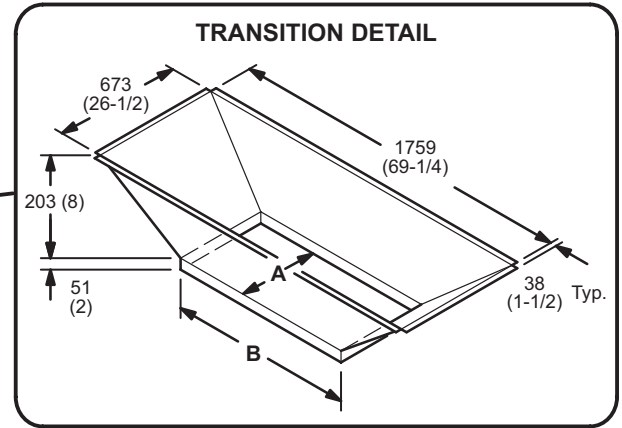

TRANSITION OPENING SIZES

Model Number	A		B	
	mm	inch	mm	inch
C1DIFF33C-1	457	18	914	36
C1DIFF34C-1	610	24	1219	48

DIMENSIONS - ACCESSORIES

HORIZONTAL ROOF CURBS – Requires Optional Horizontal Return Air Panel Kit

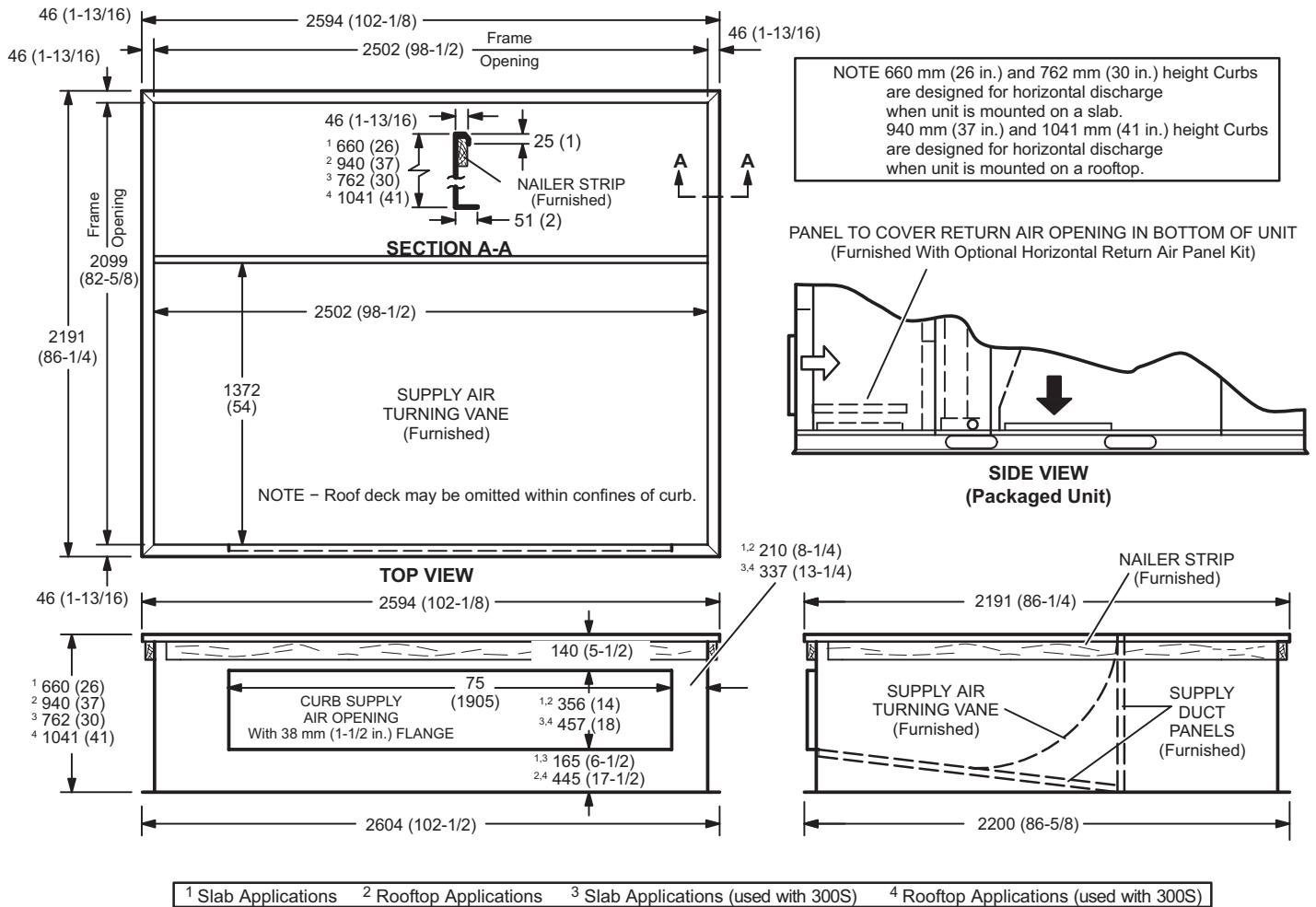

HORIZONTAL SUPPLY AND RETURN AIR OPENINGS WITH HORIZONTAL ROOF CURB

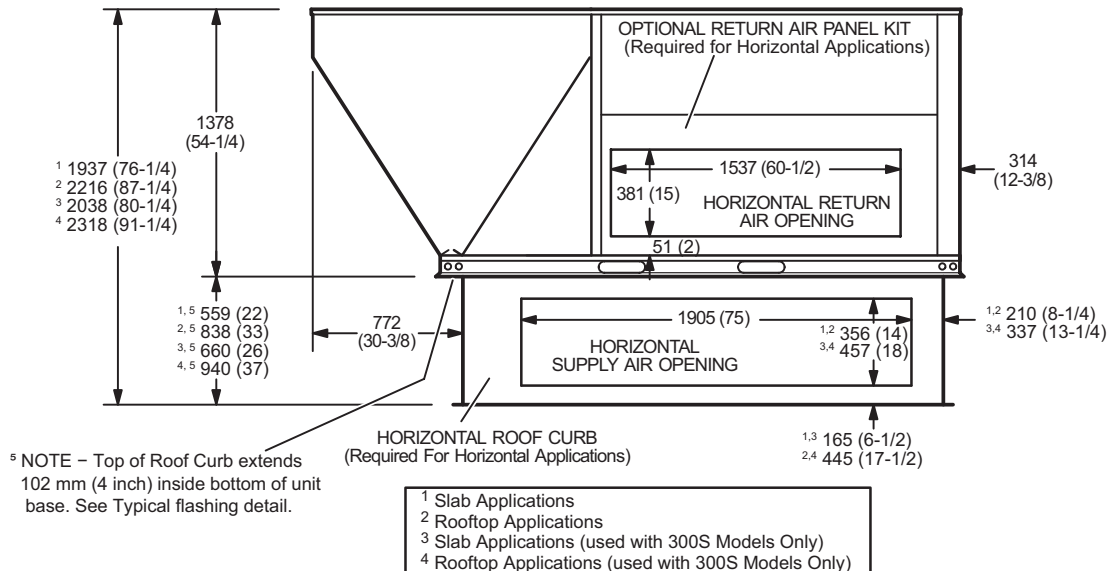

DIMENSIONS - ACCESSORIES

COMBINATION CEILING SUPPLY AND RETURN DIFFUSERS

STEP-DOWN CEILING DIFFUSER

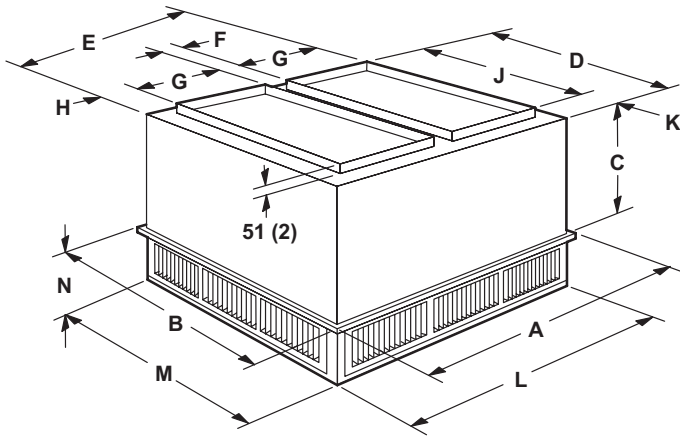

FLUSH CEILING DIFFUSER

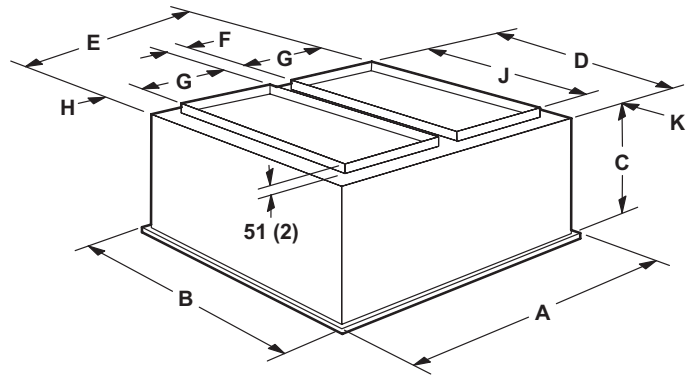

Model Number		RTD11-185S	RTD11-275S
A	mm	1210	1514
	in.	47-5/8	59-5/8
B	mm	1210	1514
	in.	47-5/8	59-5/8
C	mm	625	778
	in.	24-5/8	30-5/8
D	mm	1156	1461
	in.	45-1/2	57-1/2
E	mm	1156	1461
	in.	45-1/2	57-1/2
F	mm	114	114
	in.	4-1/2	4-1/2
G	mm	457	610
	in.	18	24
H	mm	64	64
	in.	2-1/2	2-1/2
J	mm	914	1219
	in.	36	48
K	mm	121	121
	in.	4-3/4	4-3/4
L	mm	1156	1461
	in.	45-1/2	57-1/2
M	mm	1156	1461
	in.	45-1/2	57-1/2
N	mm	257	283
	in.	10-1/8	11-1/8
Duct Size	mm	457 x 914	610 x 1219
	in.	18 x 36	24 x 48

Model Number		FD11-185S	FD11-275S
A	mm	1210	1514
	in.	47-5/8	59-5/8
B	mm	1210	1514
	in.	47-5/8	59-5/8
C	mm	743	895
	in.	29-1/4	35-1/4
D	mm	1143	1148
	in.	45	57
E	mm	1143	1448
	in.	45	57
F	mm	114	114
	in.	4-1/2	4-1/2
G	mm	457	610
	in.	18	24
H	mm	57	57
	in.	2-1/4	2-1/4
J	mm	914	1219
	in.	36	48
K	mm	114	114
	in.	4-1/2	4-1/2
Duct Size	mm	457 x 914	610 x 1219
	in.	18 x 36	24 x 48

REVISIONS

Sections	Description of Change
Options/Accessories	High Performance Economizer information updated.



Visit us at www.Lennox.com

For the latest technical information, www.LennoxCommercial.com

Contact us at 1-800-4-LENNOX

NOTE - Due to Lennox' ongoing commitment to quality, Specifications, Ratings and Dimensions subject to change without notice and without incurring liability. Improper installation, adjustment, alteration, service or maintenance can cause property damage or personal injury. Installation and service must be performed by a qualified installer and servicing agency.

©2022 Lennox Industries, Inc.