

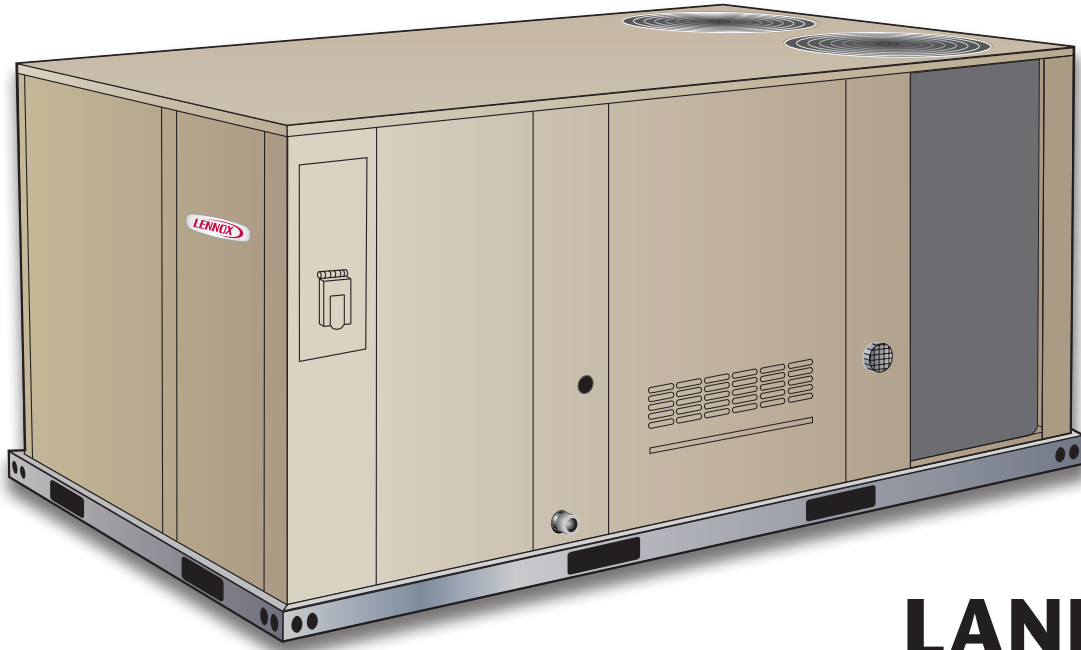

COMMERCIAL
PRODUCT SPECIFICATIONS

Bulletin No. 490169
May 2022
Supersedes March 2021



LANDMARK®
Performance Marked by Flexibility™

26 to 30 kW
Net Cooling Capacity - 22.5 to 24.9 kW (77 000 to 85 000 Btuh)
Net Heating Capacity - 22.2 to 25.4 kW (76 000 to 87 000 Btuh)
Gas Input Heat Capacity - 24.7 to 70.3 kW (84 500 to 240 000 Btuh)

MODEL NUMBER IDENTIFICATION

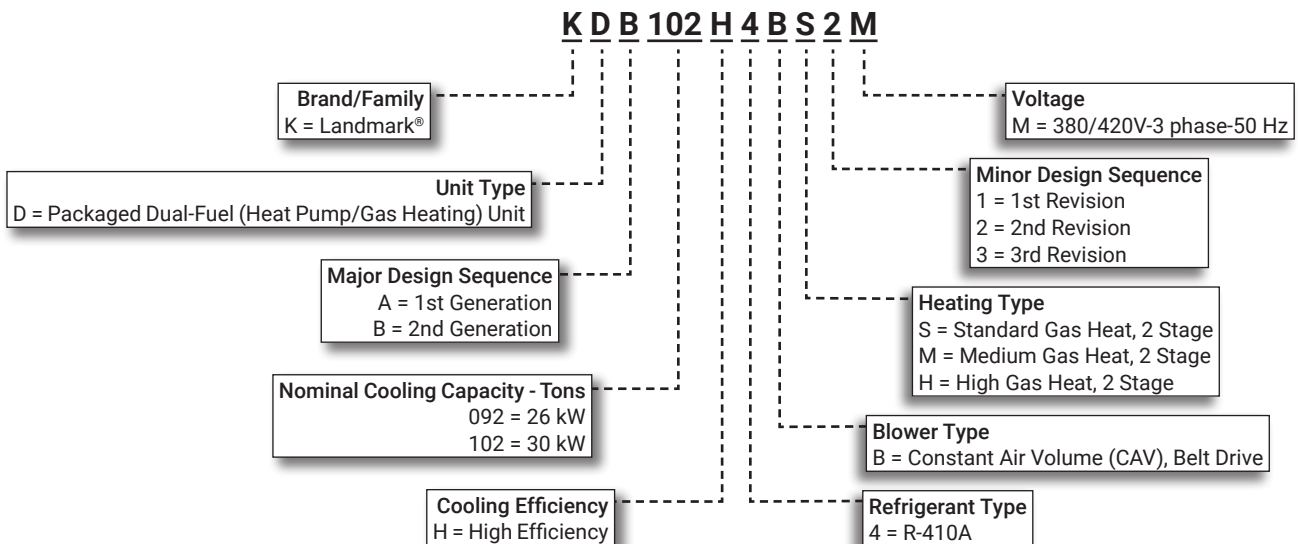

FEATURE HIGHLIGHTS

Landmark® rooftop units from Lennox are the new standard for reliable, efficient rooftop units built for long-lasting performance that can significantly improve indoor environments.

1. Scroll Compressors
2. Coil Construction
3. Outdoor Coil Fans
4. Aluminized Steel Inshot Burners
5. Construction
6. Blower
7. Unit Control
8. Air Filters
9. Economizer (option)
10. Barometric Relief Dampers (option)

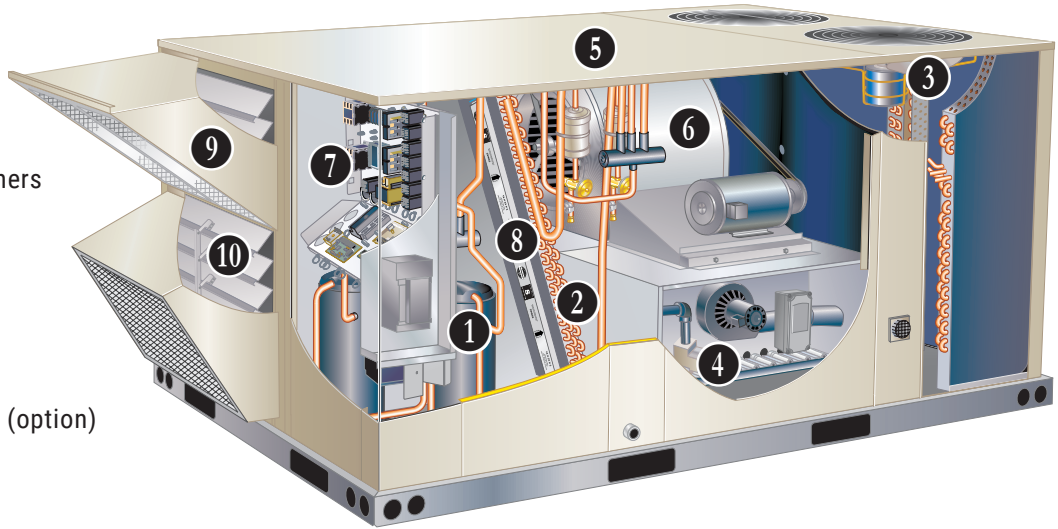

CONTENTS

Blower Data	18
Cooling / Heating Ratings	16
Dimensions	24
- Accessories	25
- Unit	24
Electrical Data	21
Feature Highlights	2
Features And Benefits	3
High Altitude Derate	15
Model Number Identification	1
Optional Conventional Temperature Control Systems	10
Options / Accessories	11
Outdoor Sound Data	22
Specifications	14
- Gas Heat	15
- Unit	14
Weight Data	23

PERFORMANCE/QUALITY

- Components bonded for grounding to meet safety standards for servicing required by Underwriters Laboratories (UL) and the International Electrotechnical Commission (IEC).
- Cooling performance is rated at test conditions included in Air- Conditioning, Heating and Refrigeration Institute (AHRI) Standard 340/360-2007 while operating at rated voltage and air volumes.
- International Organization for Standardization (ISO) 9001 Registered Manufacturing Quality System.

FEATURES AND BENEFITS

DUAL-FUEL OPERATION

- In heating mode the heat pump operates the heat pump for 1st stage heating
- If 1st stage is not satisfied, the 2nd stage will activate gas heating (secondary heat source)
- Mechanical heat pump operation is automatically terminated on gas heat start-up
- Unit control automatically changes blower speeds between heat pump heating and gas heat operation
- Blower operates in high speed during 1st stage (heat pump) operation and is terminated during changeover to gas heat operation
- Blower starts up when heat exchanger is warm, and runs in high speed during 2nd stage (gas heat) operation
- If continuous blower operation is available on thermostat, change in blower speed automatically occurs during heat pump heat to gas heat changeover

COOLING/HEATING SYSTEM

- Designed to maximize sensible and latent cooling performance at design conditions
- System can operate in the cooling mode from 1°C to 52°C without any additional controls

R-410A Refrigerant

- Non-chlorine based
- Ozone friendly

1 Scroll Compressors

- Scroll compressors on all models for high performance, reliability and quiet operation
- Resiliently mounted on rubber grommets for quiet operation

Compressor Crankcase Heaters

- Protects against refrigerant migration that can occur during low ambient operation

Check/Thermal Expansion Valves

- Ensures optimal performance throughout the application range
- Removable element head

Reversing Valves

- 4-way interchange reversing valve effects a rapid change in direction of refrigerant flow resulting in quick changeover from cooling to heating and vice versa

Filter/Driers

- High capacity filter/drier protects the system from dirt and moisture

High Pressure Switches

- Protects the compressor from overload conditions such as dirty condenser coils, blocked refrigerant flow, or loss of outdoor fan operation
- Automatic reset

Freezestats

- Protects the evaporator coil from damaging ice build-up due to conditions such as low/no airflow, or low refrigerant charge

2 Coil Construction

- Copper tube construction
- Enhanced rippled-edge aluminum fins
- Flared shoulder tubing connections
- Silver soldered construction
- Factory leak tested

Indoor Coil

- Cross row circuiting
- Rifled copper tubing

Condenser Coil

- Two independent formed coils allow separation for cleaning

Condensate Drain Pan

- Plastic pan, sloped to meet drainage requirements of ASHRAE 62.1
- Side or bottom drain connections
- Reversible to allow connection at back of unit

Outdoor Coil Fan Motors

- All models have variable speed (ECM) fan motors for energy efficient operation and quiet operation
- Thermal overload protected
- Totally enclosed
- Permanently lubricated ball bearings
- Shaft up
- Wire basket mount

3 Outdoor Coil Fans

- Polyvinyl Chloride (PVC) coated fan guard furnished

FEATURES AND BENEFITS

COOLING/HEATING SYSTEM (continued)

Required Selections

Cooling Capacity

- Specify nominal cooling capacity

Options / Accessories

Field Installed

Condensate Drain Trap

- Available in copper or polyvinyl chloride (PVC)

Drain Pan Overflow Switch

- Monitors condensate level in drain pan
- Shuts down unit if drain becomes clogged

Low Ambient Kit

- Designed for use in ambient temperatures no lower than -17°C
- Cycles the outdoor fans while allowing compressor operation in the cooling cycle
- Includes field installed pressure switches on the liquid line to determine when to operate the outdoor fans
- Intermittent fan operation allows the system to operate without icing the evaporator coil and losing capacity
- If the liquid line pressure drops below 1.66 Pa outdoor fans operate at 25% normal fan speed
- If pressure drops below 1.24 Pa all outdoor fans stop until pressure rises to 2.07 Pa, then fans operate at 25% normal fan speed unless main pressure switches have reset to 3.1 Pa to resume normal cooling operation and full fan speed operation

GAS HEATING SYSTEM

- 4 • Aluminized steel inshot burners
- Direct spark ignition
- Electronic flame sensor
- Combustion air inducer
- Redundant automatic dual stage gas valve with manual shut-off

Heat Exchanger

- Tubular construction, stainless steel
- Life cycle tested

Electronic Pilot Ignition

- Electronic spark igniter provides positive direct ignition of burners on each operating cycle
- Permits main gas valve to stay open only when the burners are proven to be lit
- If loss of flame occurs, gas valve closes, shutting off the gas to the burners
- LED indicates status and aids in troubleshooting
- Watchguard circuit on module automatically resets ignition controls after one hour of continuous thermostat demand after unit lockout, eliminating nuisance service calls
- Factory installed in the gas heating compartment

Limit Control

- Redundant limit controls with fixed temperature setting
- Protects heat exchanger and other components from overheating

Safety Switches

- Flame roll-out switch
- Flame sensor
- Combustion air inducer proving switch
- Protects system operation

Required Selections

Gas Input Choice - Order one:

- Standard Gas Heat, 2 Stage (24.7/38.1 kW)
- Medium Gas Heat, 2 Stage (34.3/52.7 kW)
- High Gas Heat, 2 Stage (45.7/70.3 kW)

Options/Accessories

Field Installed

Bottom Gas Piping Kit

- Allows bottom gas entry

Combustion Air Intake Extensions

- Recommended for use with existing flue extension kits in areas where high snow areas can block intake air

LPG/Propane Kits

- Conversion kit to field change over units from Natural Gas to LPG/Propane

Vertical Vent Extension Kit

- Use to exhaust flue gases vertically above unit
- Required when unit vent is too close to fresh air intakes per building codes
- Also prevents ice formation on intake louvers
- Kit contains vent transition, vent tee, drain cap and installation hardware

NOTE - Straight vent pipes (102 mm B-Vent) and caps are not furnished and must be field supplied. Refer to kit instructions for additional information.

FEATURES AND BENEFITS

CABINET

5 Construction

- Heavy-gauge steel panels
- Full perimeter heavy-gauge galvanized steel base rail
- Base rails have rigging holes
- Three sides of the base rail have forklift slots
- Raised edges around duct and power entry openings in the bottom of the unit for water protection

Airflow Choice

- Units are shipped in downflow (vertical) return air flow configuration

NOTE - Units can be field converted to horizontal airflow with optional Horizontal Discharge Kit.

Duct Flanges

- Provided for horizontal duct attachment

Power/Gas Entry

- Electrical and gas lines can be brought through the unit base or through horizontal access knock-outs

Exterior Panels

- Constructed of heavy-gauge, galvanized steel
- Two-layer enamel paint finish

Insulation

- Fully insulated with non-hygroscopic fiberglass insulation (conditioned areas)
- Unit base is fully insulated
- Base insulation serves as an air seal to the roof curb, eliminating the need to add a seal during installation

Access Panels

- Filter section
- Blower/heating section
- Compressor/controls section

Options / Accessories

Factory Installed

Corrosion Protection

- Completely flexible immersed coating
- Electrodeposited dry film process
- AST ElectroFin E-Coat
- Meets Mil Spec MIL-P-53084, ASTM B117 Standard Method Salt Spray Testing
- Indoor Corrosion Protection:
 - Coated coil
 - Painted blower housing
 - Painted base
- Outdoor Corrosion Protection:
 - Coated coil
 - Painted outdoor base

Hinged Access Panels

- Tool-less access
- Filter section
- Blower/heating section
- Compressor/controls section
- Panels seal and slotted, 29 mm hex bolt quarter-turn latches provide a tight air and water seal

Field Installed

Combination Coil/Hail Guards

- Heavy gauge steel frame
- Painted to match cabinet
- Expanded metal mesh protects outdoor coil

Horizontal Discharge Kit

- Consists of duct covers to block off downflow supply and return air openings for horizontal applications
- Also includes return air duct flanges for end return air when economizer is used in horizontal applications

NOTE - When configuring unit for horizontal application with economizer, a separate Horizontal Barometric Relief Damper with Hood must be ordered separately for installation in the return air duct.

Return Air Adaptor Plate

- For same size LC/LG/LH and TC/TG/TH unit replacement
- Installs on return air opening in unit to match return air opening on existing roof curbs
- Also see Accessory Air Resistance table

FEATURES AND BENEFITS

BLOWER

- 6 • A wide selection of supply air blower options are available to meet a variety of airflow requirements

Motor

- Overload protected
- ball bearings
- Belt drive motors are offered on all models and are available in several different sizes to maximize air performance

Supply Air Blower

- Forward curved blades
- Double inlet
- Blower wheel statically and dynamically balanced
- Ball bearings
- Adjustable pulley (allows speed change)
- Blower assembly slides out of unit for servicing

Required Selections

- Order blower motor horsepower and drive kit number required when base unit is ordered
- See Drive Kit Specifications Table

CONTROLS

7 Unit Control

- All control voltage is provided via a 24V (secondary) transformer with built-in circuit breaker protection
- **Heat/Cool Staging** - Capable of up to 2 heat / 2 cool staging with a third party DDC control system or thermostat
- **Low Voltage Terminal Block** - Provides screw terminal connections for thermostat or controller wiring
- **Night Setback Mode** - Saves energy by closing outdoor air dampers and operating supply fan on thermostat demand only

Defrost Control

- Provides a defrost cycle, if needed, every 30 or 60 or 90 minutes (adjustable) of compressor on² time at outdoor coil temperature below 1.6°C
- Temperature switch mounted on outdoor coil liquid line terminates defrost cycle

Fan Control

- Provides variable speed control
- Outdoor fan motor speed will vary depending on full or part load applications

Options / Accessories

Field Installed

Smoke Detector

- Photoelectric type
- Installed in supply air section, return air section or both sections
- Available with power board and single sensor (supply or return) or power board and two sensors (supply and return)

Thermostats

- Control system and thermostat options

ELECTRICAL

Required Selections

Voltage

- Specify when ordering base unit

INDOOR AIR QUALITY

8 Air Filters

- Disposable 51 mm filters furnished as standard

Options / Accessories

Field Installed

Healthy Climate® High Efficiency Air Filter

- Disposable MERV 8 or MERV 13 (Minimum Efficiency Reporting Value based on ASHRAE 52.2) efficiency 51 mm pleated filters

Replacement Filter Media Kit With Frame

- Replaces existing pleated filter media
- Includes washable metal mesh screen and metal frame with clip for holding replaceable non-pleated filter

Healthy Climate® UVC Germicidal Lamps

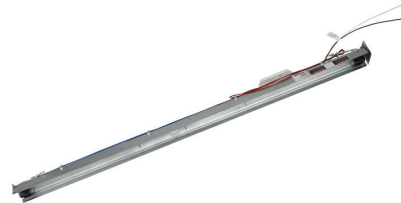

- Germicidal lamps emit ultra-violet (UV-C) energy, which has been proven to be effective in reducing microbes such as viruses, bacteria, yeasts, and molds
- This process either destroys the organism or controls its ability to reproduce
- UV-C energy greatly reduces the growth and proliferation of mold and other bioaerosols (bacteria and viruses) on illuminated surfaces (particularly coil and drain pan)
- Field installed in the blower/evaporator coil section
- Magnetic safety interlock terminates power when access panels are removed
- All necessary hardware for installation is included
- Lamps operate on 220V-1ph power supply

NOTE - Step-down transformer must be field supplied for field installation for 380/420V primary to 220V secondary.

Indoor Air Quality (CO₂) Sensors

- Monitors CO₂ levels, reports to the Unit Controller which adjusts economizer dampers as needed

ECONOMIZER

Factory or Field Installed

9 Economizer (Standard and High Performance Common Features)

- Downflow or Horizontal with Outdoor Air Hood and Barometric Relief Dampers with Exhaust Hood
- Barometric Relief Dampers allow relief of excess air
- Aluminum blade dampers prevent blow back and outdoor air infiltration during off cycle
- Bird screen furnished

NOTE - Optional Horizontal Low Profile Barometric Relief Dampers with Exhaust Hood are available for field installation in a reduced space.

- Occupied/Unoccupied mode with field furnished setback thermostat
- Demand Control Ventilation (DCV) ready using optional CO₂ sensors
- Mixed Air Sensor is furnished for field installation in the rooftop unit
- Sensor is factory installed when Economizers are factory installed
- Single sensible sensor is furnished with Economizer and enables economizer operation if the outdoor temperature is less than the setpoint of the control

Standard Economizer Features

- Gear-driven action
- Return air and outdoor air dampers
- Plug-in connections to unit
- Nylon bearings
- Neoprene seals
- 24-volt
- Fully-modulating spring return motor
-

Standard Economizer Control Module

- Standard Economizer Control Module operation is based on outdoor air temperatures



Economizer Controls:

- **Damper Minimum Position** - Can be set lower than traditional minimum air requirements resulting in cost savings
- **IAQ Sensor** - Signals dampers to modulate and maintain 55°F when CO₂ is higher than the CO₂ setpoint
- **Demand Control Ventilation (DCV) LED** - A steady green Demand Control Ventilation LED indicates the IAQ reading is higher than setpoint and requires more fresh air
- **Free Cool LED** - A steady green LED indicates outdoor air is suitable for free cooling
 - Free Cooling runs when outdoor air temperature is lower than the set temperature on the economizer control

NOTE: The Free Cooling default setting for outdoor air temperature sensor is 55°F.

High Performance Economizer Features

- Gear-driven action
- High torque 24-volt fully-modulating spring return damper motor
- Return air and outdoor air dampers
- Plug-in connections to unit
- Stainless steel bearings
- Enhanced thermoplastic vulcanizate (TPV) seals
- Flexible stainless steel jamb seals

OPTIONS / ACCESSORIES

ECONOMIZER (continued)

High Performance Economizer Control Module

- Provides inputs and outputs to control economizer based on parameter settings
- Free cooling based on single dry bulb temperature, or combination temperature + humidity sensors
- Automatic switchover for different control modes
- Parameter settings based on climate zone, using GPS functionality in the Climatix Mobile application
- LED indication for free cooling operation, sensor operation and damper operation
- Quick installation and easy commissioning with the **Climatix Mobile App** on a mobile device

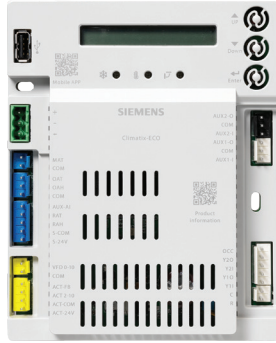

NOTE - WLAN Stick is required for App connection to module(s).

- Module displays any alarm messages (fault detection and diagnostics) as an aid in troubleshooting
- RS485 port for BACnet MSTP or Modbus RTU communication
- USB port for firmware updates and WLAN connection for setup and commissioning
- QR codes on module for quick access to download Climatix Mobile App and user documentation
- User Interface for normal operation, parameter setup, and alarm notifications with an LCD display and three operation buttons:
 1. **Up Button** - Move to the previous value, step or category
 2. **Down Button** - Move to the next value, step or category
 3. **Enter Button** -
 - Press to edit the current value or option
 - Press to confirm a newly selected value or option
 - Press Enter + Up to jump up one category
 - Press Enter + Down to jump down one category

NOTE - Refer to Installation Instructions for complete setup information and menu parameters available.

Factory or Field Installed

Single Enthalpy Temperature Control

- Outdoor air enthalpy sensor enables economizer if the outdoor enthalpy is less than the setpoint of the control

Field Installed

Differential Enthalpy Control

- Order two Single Enthalpy Controls:
 - One is field installed in the return air section
 - One in the outdoor air section
- Allows the economizer control board to select between outdoor air or return air, whichever has lower enthalpy

WLAN Stick

- Required for Climatix Mobile App usage
- Plugs into USB port on Module to provide a temporary WLAN connection for setup, commissioning, and servicing

NOTE - Only one WLAN Stick is required and can be used on multiple modules.

EXHAUST

Field Installed

Horizontal Low Profile Barometric Relief Dampers

- Replaces barometric relief dampers furnished with Economizer
- For use when unit is configured for horizontal applications in a reduced space requiring an economizer
- Allows relief of excess air
- Aluminum blade dampers prevent blow back and outdoor air infiltration during off cycle
- Field installed in return air duct
- Exhaust hood with bird screen furnished

NOTE - Requires Horizontal Discharge Kit.

11 Power Exhaust Fan

- Installs internal to unit for downflow applications only with economizer option
- Provides exhaust air pressure relief
- Interlocked to run when supply air blower is operating fan runs when outdoor air dampers are 50% open (adjustable)
- Motor is overload protected
- Requires Economizer with Outdoor Air Hood and Barometric Relief Dampers
- Fan is 508 mm diameter
- 5 blades (K1PWRE10B)
- 0.25 kW motor

OPTIONS / ACCESSORIES

OUTDOOR AIR

Factory or Field Installed

Outdoor Air Damper - Downflow or Horizontal With Air Hood

- Linked mechanical dampers
- 0 to 25% (fixed) outdoor air adjustable
- Installs in unit
- Includes outdoor air hood
- Motorized model features fully modulating spring return damper motor with plug-in connection
- Manual model features a slide damper
- Maximum mixed air temperature in cooling mode: 38°C

ROOF CURBS

Field Installed

- Nailer strip furnished (downflow only)
- Mates to unit
- US National Roofing Contractors Approved
- Shipped knocked down

Hybrid Roof Curbs, Downflow

- Interlocking tabs fasten corners together
- No tools required
- Can also be fastened together with furnished hardware
- Available in 203, 356, 457, and 610 mm heights

Adjustable Pitch Curb

- Fully adjustable pitch curbs provide a level platform for rooftop units allowing flexible installations on roofs with uneven or sloped angles
- Interlocking tabs fasten corners together
- No tools required for assembly
- Hardware is furnished to connect upper curb with lower curb
- Available in 356 mm height

Adaptor Curbs (not shown)

- Curbs are regionally sourced
- Dimensions vary based upon the source

NOTE - Contact your local sales representative for a detailed cut sheet with applicable dimensions.

CEILING DIFFUSERS

Field Installed

Ceiling Diffusers
(Flush or Step-Down)

- White powder coat finish on diffuser face and grilles
- Insulated UL listed duct liner
- Diffuser box has collars for duct connection
- Step-down diffusers have double deflection blades
- Flush diffusers have fixed blades
- Provisions for suspending
- Internally sealed to prevent recirculation
- Removable return air grille
- Adapts to T-bar ceiling grids or plaster ceilings

Transitions (Supply and Return)

- Used with diffusers
- Installs in roof curb
- Galvanized steel construction
- Flanges furnished for duct connection to diffusers
- Fully insulated

OPTIONAL CONVENTIONAL TEMPERATURE CONTROL SYSTEMS

ComfortSense® 7500 Commercial 7-Day Programmable Thermostat



- Four-Stage Heating / Two-Stage Cooling
- Universal Multi-Stage
- Intuitive Touchscreen Interface
- Automatic Changeover between Heating and Cooling
- Full Seven-Day Programming
- Four Time Periods Per Day
- Temperature and Humidity Control
- One-Touch Away Mode
- Holiday Scheduling
- Smooth Setback Recovery (SSR)
- Performance Reports
- Notifications/Reminders
- Dehumidification/Humiditrol® Control for Split Systems and Rooftop Units
- Economizer Relay Control
- Backlit Display
- Wallplate Furnished
- FDD, ASHRAE, and IECC Compliant

ComfortSense® 3000 Commercial 5-2 Day Programmable Thermostat

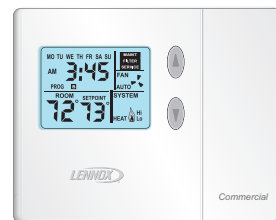

- Two-Stage Heating / Two-Stage Cooling
- Conventional Systems
- Intuitive Interface
- 5-2 Day Programming
- Program Hold
- Remote Indoor Temperature Sensing
- Smooth Setback Recovery (SSR)
- Economizer Relay Control
- Maintenance/Filter/Service Reminders
- Backlit Display
- Wallplate Furnished
- Simple Up and Down Temperature Control

BACnet Compatible Thermostat With Reheat Function



- 7-Day Programmable
- For units with or without Humiditrol®
- BTL listed MS/TP ensures compatibility with any BACnet system
- Built-in control programs for conventional and heat pump applications
- Conventional systems up to 3-stage heat and 3-stage cool
- Heat pumps with 1 or 2 compressors and up to 2-stage auxiliary heat
- On-board temperature and humidity sensor
- Multiple configurable inputs and outputs enable advanced control strategies
- Set-up Wizard enables rapid system configuration
- No special tools required for installation or commissioning
- Seven-day (2, 4 or 6 event) occupancy scheduling per day
- Backlit 5-inch LCD touchscreen

Description

Catalog No.

ComfortSense® 7500 Commercial 7-Day Programmable Thermostat

CS7500 7-Day Thermostat		17G74
Sensors/	¹ Remote non-adjustable wall-mount 20k	47W36
Accessories	¹ Remote non-adjustable wall-mount 10k	47W37
	Remote non-adjustable discharge air (duct mount)	19L22
	Outdoor temperature sensor	X2658

ComfortSense® 3000 5-2 Day Programmable

CS3000 5-2 Day Thermostat		11Y05
Sensor/	Remote non-adjustable wall mount 10k averaging	47W37
Accessories	Thermostat wall mounting plate	X2659
BACnet	² 7-Day BACnet Thermostat	Y8241
Controls	³ BACnet Module (factory or field)	16X71
⁴ BACnet	With Display	97W23
Room Sensors	Without Display	97W24

Universal Thermostat Guard with Lock (clear)

Inside Dimensions (H x W) 5 7/8 x 8 3/8 in.		39P21
---	--	--------------

¹ Remote wall-mount sensors can be applied in any of the following combinations:
 One Sensor - (1) 47W36, Two Sensors - (2) 47W37, Three Sensors - (2) 47W36 and (1) 47W37
 Four Sensors - (4) 47W36, Five Sensors - (3) 47W36 and (2) 47W37

² BACnet Thermostat (Y8241) will control units with and without the Humiditrol® option. If there is a mix of units equipped with and without Humiditrol on the same site, this thermostat can be used for all units if suitable.

³ Not compatible with units equipped with Humiditrol® option.

⁴ Only compatible with BACnet Module (16X70).

OPTIONS / ACCESSORIES

Item Description	Model Number	Catalog Number	Unit Model No	
			KDB 092	KDB 102
COOLING/HEATING SYSTEM				
Condensate Drain Trap	Polyvinyl Chloride (PVC)	22H54	X	X
	Copper	76W27	X	X
Corrosion Protection		Factory	O	O
Drain Pan Overflow Switch		74W42	X	X
Efficiency		High	O	O
Low Ambient Kit		14N31	X	X
Refrigerant Type		R-410A	O	O
GAS HEATING SYSTEM				
Bottom Gas Piping Kit		54W95	X	X
Combustion Air Intake Extensions		19W51	X	X
Gas Heat Input	Standard Heat 38.1 kW (130 000 Btuh)	Factory	O	O
	Medium Heat 52.7 kW (180 000 Btuh)	Factory	O	O
	High Heat 70.3 kW (240 000 Btuh)	Factory	O	O
LPG/Propane Conversion Kits	Standard Heat	14N22	X	X
	Medium Heat	14N23	X	X
	High Heat	14N25	X	X
Vertical Vent Extension		42W16	X	X
BLOWER - SUPPLY AIR				
Motors	Belt Drive - 1.5 kW (2 hp)	Factory	O	O
	Belt Drive - 2.2 kW (3 hp)	Factory	O	O
	Belt Drive - 3.7 kW (5 hp)	Factory	O	O
Drive Kits	Kit #1 490-740 rev/min	Factory	O	O
See Blower Data Tables for selection	Kit #2 665-920 rev/min	Factory	O	O
	Kit #3 660-995 rev/min	Factory	O	O
	Kit #7 610-810 rev/min	Factory	O	O
	Kit #8 780-1000 rev/min	Factory	O	O
	Kit #9 845-1085 rev/min	Factory	O	O
	Kit #10 750-945 rev/min	Factory	O	O
	Kit #11 865-1095 rev/min	Factory	O	O
	Kit #12 940-1190 rev/min	Factory	O	O
	CABINET			
Combination Coil/Hail Guards		14Y77	X	X
Hinged Access Panels		Factory	O	O
Horizontal Discharge Kit		51W25	X	X
Return Air Adaptor Plate (for LC/LG/LH and TC/TG/TH unit replacement)		54W96	X	X

NOTE - Catalog and model numbers shown are for ordering field installed accessories.

OX - Configure To Order (Factory Installed) or Field Installed

O = Configure To Order (Factory Installed)

X = Field Installed

OPTIONS / ACCESSORIES

Item Description	Model Number	Catalog Number	Unit Model No	
			KDB 092	KDB 102

CONTROLS

NOTE - Also see Conventional Thermostat Control Systems on page 10 for Additional Options.

Smoke Detector - Supply or Return (Power board and one sensor)		11K76	X	X
Smoke Detector - Supply and Return (Power board and two sensors)		11K80	X	X

INDOOR AIR QUALITY

Air Filters

Healthy Climate® High Efficiency Air Filters 208 x 635 x 51 mm (Order 4 per unit)	MERV 8	50W61	X	X
	MERV 13	52W41	X	X
Replacement Media Filter With Metal Mesh Frame (includes non-pleated filter media)		Y3063	X	X

Indoor Air Quality (CO₂) Sensors

Sensor - Wall-mount, off-white plastic cover with LCD display		77N39	X	X
Sensor - Wall-mount, off-white plastic cover, no display		87N53	X	X
Sensor - Black plastic case with LCD display, rated for plenum mounting		87N52	X	X
Sensor - Wall-mount, black plastic case, no display, rated for plenum mounting		87N54	X	X
CO ₂ Sensor Duct Mounting Kit - for downflow applications		85L43	X	X
Aspiration Box - for duct mounting non-plenum rated CO ₂ sensors (87N53 or 77N39)		90N43	X	X

UVC Germicidal Lamps

¹ Healthy Climate® UVC Light Kit (220V-1ph)		21A93	X	X
--	--	--------------	---	---

ELECTRICAL

Voltage 50 Hz with neutral	380/420V - 3 phase	Factory	O	O
----------------------------	--------------------	---------	---	---

¹ Lamps operate on 220V single-phase power supply. Step-down transformer must be field supplied for field installation for 380/420V primary to 220V secondary. Alternately, a separate 220V power supply may be used to directly power the UVC ballast(s).

NOTE - Catalog and model numbers shown are for ordering field installed accessories.

OX - Configure To Order (Factory Installed) or Field Installed

O = Configure To Order (Factory Installed)

X = Field Installed

OPTIONS / ACCESSORIES

Item Description	Model Number	Catalog Number	Unit Model No	
			KDB 092	KDB 102
ECONOMIZER				
Standard Economizer				
Standard Economizer with Single Temperature Control Downflow or Horizontal Applications - Includes Barometric Relief Dampers and Air Hoods		13U45	OX	OX
Standard Economizer Controls				
Single Enthalpy Control		21Z09	OX	OX
Differential Enthalpy Control (order 2)		21Z09	X	X
High Performance Economizer				
High Performance Economizer with Single Temperature Control Downflow or Horizontal Applications - Includes Barometric Relief Dampers and Air Hoods		23G23	OX	OX
High Performance Economizer Controls				
Single Enthalpy Control		23G26	OX	OX
Differential Enthalpy Control (order 2)		23G26	X	X
Horizontal Barometric Relief Dampers With Exhaust Hood				
Horizontal Barometric Relief Dampers - Exhaust Hood Furnished		53K04	X	X
OUTDOOR AIR				
Outdoor Air Dampers with Outdoor Air Hood				
Motorized		14G28	OX	OX
Manual		14G29	OX	OX
POWER EXHAUST				
Standard Static	380/420V-3ph	53W45	X	X
ROOF CURBS				
Hybrid Roof Curbs, Downflow				
203 mm height		11F54	X	X
356 mm height		11F55	X	X
457 mm height		11F56	X	X
610 mm height		11F57	X	X
Adjustable Pitch Curb				
356 mm height		54W50	X	X
CEILING DIFFUSERS				
Step-Down - Order one	RTD11-95S	13K61	X	
	RTD11-135S	13K62		X
Flush - Order one	FD11-95S	13K56	X	
	FD11-135S	13K57		X
Transitions (Supply and Return) - Order one	C1DIFF30B-1	12X65	X	
	C1DIFF31B-1	12X66		X

NOTE - Catalog and model numbers shown are for ordering field installed accessories.

OX - Configure To Order (Factory Installed) or Field Installed

O = Configure To Order (Factory Installed)

X = Field Installed

SPECIFICATIONS		UNIT	
General Data	Nominal kW (Tons)	26 (7.5)	30 (8.5)
	Model Number	KDB092H4B	KDB102H4B
	Efficiency Type	High	High
	Blower Type	Constant Air Volume CAV	Constant Air Volume CAV
Cooling Performance	Gross Cooling Capacity - kW (Btuh)	23.5 (80 300)	26.3 (90 000)
	¹ Net Cooling Capacity - kW (Btuh)	22.5 (77 000)	24.9 (85 000)
	AHRI Rated Air Flow - L/s (cfm)	1416 (3 000)	1605 (3 400)
	Total Unit Power - kW	6.2	7.2
	¹ EER (Btuh/Watt)	12.1	12.0
	² IEER (Btuh/Watt)	12.9	12.5
	Refrigerant Type	R-410A	R-410A
	Refrigerant Charge Furnished	Circuit 1 Circuit 2	6.12 kg (13.5 lbs.) 6.12 kg (13.5 lbs.)
Heating Performance	¹ Total High Heat Capacity - kW (Btuh)	22.2 (76 000)	25.4 (87 000)
	Total Unit Power - kW	5.8	6.6
	¹ Coefficient of Performance	3.6	3.6
	¹ Total Low Heat Capacity - kW (Btuh)	12.89 (44 000)	14.9 (51 000)
	Total Unit Power (kW)	5.5	6.2
¹ Coefficient of Performance	2.3	2.3	
Gas Heating Options - See page 15		Standard (2 stage), Medium (2 Stage), High (2 Stage)	
Compressor Type (number)		Scroll (2)	Scroll (2)
Outdoor Coils	Net face area (total) - m ² (sq. ft.)	2.4 (25.9)	2.4 (25.9)
	Tube diameter - mm (in.)	9.5 (3/8)	9.5 (3/8)
	Number of rows	3	3
	Fins per m (inch)	787 (20)	787 (20)
Outdoor Coil Fans	Motor - (No.) horsepower	(2) 1/3 ECM	(2) 1/3 ECM
	Motor rev/min	530-950	650-1010
	Total Motor watts	140-620	220-700
	Diameter - (No.) mm (in.)	(2) 610 (24)	(2) 610 (24)
	Number of blades	3	3
Total Air volume - L/s (cfm)		1700-3300 (3600-7000)	2170-3540 (4600-7500)
Indoor Coils	Net face area (total) - m ² (sq. ft.)	1.18 (12.8)	1.18 (12.8)
	Tube diameter - mm (in.)	9.5 (3/8)	9.5 (3/8)
	Number of rows	4	4
	Fins per m (inch)	551 (14)	551 (14)
	Drain connection - Number and size	(1) 1 in. NPT coupling	
Expansion device type		Balance port TXV, removable head	
³ Indoor Blower and Drive Selection	Nominal motor kW (HP)	1.5 (2)	1.5 (2)
	Maximum usable motor kW (HP)	1.7 (2.3)	1.7 (2.3)
	Kit # and rev/min range	⁴ #1 490 - 740	⁴ #1 490 - 740
		#2 665 - 920	#2 665 - 920
		#3 660 - 995	#3 660 - 995
	Nominal motor kW (HP)	2.2 (3)	2.2 (3)
	Maximum usable motor kW (HP)	2.6 (3.45)	2.6 (3.45)
	Kit # and rev/min range	#7 610 - 810	#7 610 - 810
		#8 780 - 1000	#8 780 - 1000
		#9 845 - 1085	#9 845 - 1085
	Nominal motor kW (HP)	3.7 (5)	3.7 (5)
	Maximum usable motor kW (HP)	4.3 (5.75)	4.3 (5.75)
Kit # and rev/min range	#10 750 - 945	#10 750 - 945	
	#11 865 - 1095	#11 865 - 1095	
	#12 940 - 1190	#12 940 - 1190	
Blower wheel nominal diameter x width - mm (in.)		(1) 381 x 381 (15 X 15)	(1) 381 x 381 (15 X 15)
Filters	Type of filter	Disposable	
	Number and size - in.	(4) 508 x 508 x 51 (20 x 25 x 2)	
Electrical characteristics		380/420V - 50 hertz - 3 phase with neutral	

NOTE - Net capacity includes evaporator blower motor heat deduction. Gross capacity does not include evaporator blower motor heat deduction.

¹ Tested at conditions included in the ULE certification program, which is based on AHRI Standard 340/360 while operating at rated voltage and air volumes:

Cooling Ratings – 35°C (95°F) outdoor air temperature and 27°C (80°F) db/19°C (67°F) wb entering indoor coil air.

High Temperature Heating Ratings – 8°C (47°F) db/6°C (43°F) wb outdoor air temperature and 21°C (70°F) entering indoor coil air.

Low Temperature Heating Ratings – -8°C (17°F) db/-9°C (15°F) wb outdoor air temperature and 21°C (70°F) entering indoor coil air.

² Integrated Energy Efficiency Ratio tested at conditions included in AHRI Standard 340/360 while operating at rated voltage and air volumes.

³ Using total air volume and system static pressure requirements determine from blower performance tables rev/min and motor output required. Maximum usable output of motors furnished are shown. If motors of comparable output are used, be sure to keep within the service factor limitations outlined on the motor nameplate.

⁴ Standard motor and drive kit furnished with unit.

SPECIFICATIONS

GAS HEAT

			Standard	Medium	High
Heat Input Type					
Number of Gas Heat Stages			2	2	2
Gas Heating Performance	Input - kW (Btuh)	First Stage	24.8 (84 500)	34.3 (117 000)	45.7 (156 000)
		Second Stage	33.4 (114 000)	46.7 (159 500)	61.5 (210 000)
	Output - kW (Btuh) Second Stage		26.7 (91 200)	36.9 (126 000)	49.2 (168 000)
	Temperature Rise Range - °C (°F)		8 - 25 (15 - 45)	17 - 33 (30 - 60)	22 - 39 (40 - 70)
Thermal Efficiency			81%	81%	81%
Gas Supply Connections			3/4 in. NPT	3/4 in. NPT	3/4 in. NPT
Recommended Gas Supply Pressure - kPa (in. w.g.)	Natural		0.70 (2.8)	0.70 (2.8)	0.70 (2.8)
	LPG/Propane		1.97 (7.9)	1.97 (7.9)	1.97 (7.9)

HIGH ALTITUDE DERATE

Units may be installed at altitudes up to 610 m (2000 feet) above sea level without any modification.

At altitudes above 610 m (2000 feet), units must be derated to match gas manifold pressures shown in table below.

At altitudes above 1372 m (4500 feet) unit must be derated 2% for each 305 m (1000 feet) above sea level.

NOTE - This is the only permissible derate for these units.

Gas Heat Type	Altitude m (Feet)	Gas Manifold Pressure kPa (in. w.g.)		Input Rate - Btuh (Natural Gas or LPG/Propane)	
		Natural Gas	LPG/Propane Gas	First Stage	Second Stage
Standard	610 - 1372 (2001-4500)	0.62 (2.5)	1.82 (7.3)	24.8 (84 500)	31.7 (108 000)
Medium	610 - 1372 (2001-4500)	0.62 (2.5)	1.82 (7.3)	34.3 (117 000)	43.7 (149 000)
High	610 - 1372 (2001-4500)	0.62 (2.5)	1.82 (7.3)	45.7 (156 000)	58 (198 000)

COOLING / HEATING RATINGS

NOTE – For Temperatures and Capacities not shown in tables, see bulletin – Cooling Unit Rating Table Correction Factor Data in Miscellaneous Engineering Data section.

26 KW COOLING HIGH EFFICIENCY KDB092H4 (1ST STAGE)

Entering Wet Bulb Temperature	Total Air Volume	Outdoor Air Temperature Entering Outdoor Coil																			
		18.3°C					23.9°C					29.4°C					35°C				
		Total Cool Cap.	Comp. Motor Input	Sensible To Total Ratio (S/T)			Total Cool Cap.	Comp. Motor Input	Sensible To Total Ratio (S/T)			Total Cool Cap.	Comp. Motor Input	Sensible To Total Ratio (S/T)			Total Cool Cap.	Comp. Motor Input	Sensible To Total Ratio (S/T)		
				Dry Bulb					Dry Bulb					Dry Bulb					Dry Bulb		
L/s	kW	kW	24°C	27°C	29°C	kW	kW	24°C	27°C	29°C	kW	kW	24°C	27°C	29°C	kW	kW	24°C	27°C	29°C	
17.2°C	1135	12.3	1.91	0.68	0.85	1.00	11.2	2.15	0.69	0.88	1.00	10.1	2.42	0.69	0.92	1.00	9.0	2.73	0.70	0.96	1.00
	1415	13.0	1.93	0.74	0.98	1.00	12.0	2.16	0.75	1.00	1.00	10.9	2.43	0.77	1.00	1.00	9.9	2.74	0.80	1.00	1.00
	1700	13.8	1.94	0.82	1.00	1.00	12.8	2.18	0.84	1.00	1.00	11.7	2.45	0.88	1.00	1.00	10.6	2.76	0.93	1.00	1.00
19.4°C	1135	13.3	1.93	0.52	0.66	0.81	12.2	2.17	0.52	0.67	0.83	11.0	2.44	0.51	0.68	0.87	9.8	2.74	0.50	0.68	0.91
	1415	14.0	1.94	0.57	0.72	0.93	12.8	2.18	0.56	0.74	0.97	11.6	2.45	0.57	0.75	1.00	10.3	2.75	0.56	0.77	1.00
	1700	14.5	1.95	0.61	0.80	1.00	13.3	2.19	0.60	0.82	1.00	12.0	2.46	0.61	0.86	1.00	10.8	2.76	0.60	0.91	1.00
21.7°C	1135	14.3	1.95	0.39	0.52	0.65	13.2	2.19	0.38	0.52	0.65	12.0	2.46	0.36	0.51	0.66	10.8	2.76	0.33	0.50	0.67
	1415	15.0	1.96	0.42	0.56	0.71	13.8	2.20	0.39	0.56	0.72	12.6	2.47	0.39	0.57	0.74	11.3	2.77	0.36	0.56	0.76
	1700	15.5	1.97	0.43	0.60	0.77	14.3	2.21	0.42	0.61	0.79	13.0	2.48	0.41	0.61	0.83	11.7	2.78	0.39	0.61	0.88

26 KW COOLING HIGH EFFICIENCY KDB092H4 (2ND STAGE)

Entering Wet Bulb Temperature	Total Air Volume	Outdoor Air Temperature Entering Outdoor Coil																			
		26.7°C					35°C					43.3°C					51.7°C				
		Total Cool Cap.	Comp. Motor Input	Sensible To Total Ratio (S/T)			Total Cool Cap.	Comp. Motor Input	Sensible To Total Ratio (S/T)			Total Cool Cap.	Comp. Motor Input	Sensible To Total Ratio (S/T)			Total Cool Cap.	Comp. Motor Input	Sensible To Total Ratio (S/T)		
				Dry Bulb					Dry Bulb					Dry Bulb					Dry Bulb		
L/s	kW	kW	24°C	27°C	29°C	kW	kW	24°C	27°C	29°C	kW	kW	24°C	27°C	29°C	kW	kW	24°C	27°C	29°C	
17.2°C	1135	22.6	4.19	0.75	0.92	1.00	21.1	4.75	0.76	0.95	1.00	19.5	5.39	0.78	0.98	1.00	17.8	6.13	0.81	1.00	1.00
	1415	23.8	4.20	0.81	1.00	1.00	22.4	4.75	0.83	1.00	1.00	21.0	5.39	0.87	1.00	1.00	19.3	6.13	0.91	1.00	1.00
	1700	25.2	4.20	0.89	1.00	1.00	23.7	4.75	0.92	1.00	1.00	22.0	5.38	0.96	1.00	1.00	20.4	6.12	1.00	1.00	1.00
19.4°C	1135	24.2	4.20	0.58	0.70	0.88	22.6	4.75	0.58	0.74	0.91	20.9	5.39	0.58	0.76	0.94	19.0	6.13	0.60	0.78	0.99
	1415	25.3	4.21	0.61	0.79	0.98	23.5	4.75	0.63	0.81	1.00	21.7	5.38	0.63	0.84	1.00	19.9	6.12	0.66	0.89	1.00
	1700	26.1	4.21	0.65	0.86	1.00	24.3	4.75	0.67	0.89	1.00	22.4	5.38	0.69	0.94	1.00	20.5	6.12	0.71	0.98	1.00
21.7°C	1135	25.8	4.21	0.42	0.56	0.70	24.2	4.75	0.42	0.57	0.72	22.4	5.38	0.41	0.58	0.74	20.5	6.13	0.41	0.59	0.76
	1415	26.9	4.22	0.43	0.60	0.77	25.2	4.76	0.44	0.62	0.79	23.3	5.38	0.43	0.63	0.82	21.3	6.12	0.43	0.65	0.86
	1700	27.7	4.21	0.45	0.66	0.84	25.9	4.76	0.46	0.66	0.87	23.9	5.38	0.46	0.68	0.91	21.9	6.12	0.46	0.71	0.96

Entering Wet Bulb Temperature	Total Air Volume	Outdoor Air Temperature Entering Outdoor Coil																	
		46°C					48°C					50°C							
		Total Cool Cap.	Comp. Motor Input	Sensible To Total Ratio (S/T)			Total Cool Cap.	Comp. Motor Input	Sensible To Total Ratio (S/T)			Total Cool Cap.	Comp. Motor Input	Sensible To Total Ratio (S/T)					
				Dry Bulb					Dry Bulb					Dry Bulb					
L/s	kW	kW	24°C	27°C	29°C	kW	kW	24°C	27°C	29°C	kW	kW	24°C	27°C	29°C				
17.2°C	1135	17.9	6.11	0.82	1.00	1.00	17.3	6.42	0.84	1.00	1.00	16.7	6.72	0.85	1.00	1.00			
	1415	19.4	6.12	0.92	1.00	1.00	18.7	6.41	0.94	1.00	1.00	18.1	6.71	0.95	1.00	1.00			
	1700	20.4	6.10	1.00	1.00	1.00	19.8	6.40	1.00	1.00	1.00	19.1	6.71	1.00	1.00	1.00			
19.4°C	1135	19.0	6.12	0.60	0.80	0.99	18.4	6.40	0.61	0.81	1.00	17.7	6.72	0.61	0.83	1.00			
	1415	19.9	6.11	0.67	0.90	1.00	19.2	6.40	0.67	0.91	1.00	18.4	6.70	0.68	0.93	1.00			
	1700	20.6	6.11	0.73	0.98	1.00	19.8	6.40	0.74	1.00	1.00	19.1	6.71	0.75	1.00	1.00			
21.7°C	1135	20.5	6.11	0.41	0.59	0.77	19.8	6.40	0.41	0.60	0.79	19.0	6.71	0.41	0.61	0.80			
	1415	21.4	6.10	0.44	0.66	0.87	20.6	6.39	0.44	0.67	0.89	19.9	6.70	0.44	0.68	0.91			
	1700	21.9	6.10	0.47	0.72	0.96	21.2	6.39	0.47	0.73	0.98	20.3	6.70	0.47	0.75	0.99			

26 KW HEATING HIGH EFFICIENCY KDB092H4

Indoor Coil Air Volume 21°C Dry Bulb	Air Temperature Entering Outdoor Coil									
	18°C		7°C		-4°C		-15°C		-28°C	
	Total Heating Capacity	Comp. Motor Input	Total Heating Capacity	Comp. Motor Input	Total Heating Capacity	Comp. Motor Input	Total Heating Capacity	Comp. Motor Input	Total Heating Capacity	Comp. Motor Input
L/s	kW	kW	kW	kW	kW	kW	kW	kW	kW	kW
1135	27.9	4.32	20.5	4.43	13.0	4.53	6.6	4.36	3.5	3.17
1415	28.4	4.07	20.9	4.18	13.5	4.28	7.1	4.10	3.9	2.91
1700	28.8	3.91	21.3	4.02	13.8	4.12	7.4	3.94	4.3	2.75

COOLING / HEATING RATINGS

NOTE – For Temperatures and Capacities not shown in tables, see bulletin – Cooling Unit Rating Table Correction Factor Data in Miscellaneous Engineering Data section.

30 KW COOLING HIGH EFFICIENCY KDB102H4 (1ST STAGE)

Entering Wet Bulb Temperature	Total Air Volume	Outdoor Air Temperature Entering Outdoor Coil																			
		18.3°C					23.9°C					29.4°C					35°C				
		Total Cool Cap.	Comp. Motor Input	Sensible To Total Ratio (S/T)			Total Cool Cap.	Comp. Motor Input	Sensible To Total Ratio (S/T)			Total Cool Cap.	Comp. Motor Input	Sensible To Total Ratio (S/T)			Total Cool Cap.	Comp. Motor Input	Sensible To Total Ratio (S/T)		
				Dry Bulb					Dry Bulb					Dry Bulb					Dry Bulb		
L/s	kW	kW	24°C	27°C	29°C	kW	kW	24°C	27°C	29°C	kW	kW	24°C	27°C	29°C	kW	kW	24°C	27°C	29°C	
17.2°C	1285	13.6	2120	0.66	0.85	1.00	11.8	2420	0.65	0.87	1.00	10.0	2750	0.64	0.90	1.00	8.1	3110	0.62	0.95	1.00
	1605	14.7	2130	0.73	0.97	1.00	12.9	2430	0.73	1.00	1.00	11.2	2770	0.74	1.00	1.00	9.4	3130	0.75	1.00	1.00
	1925	15.8	2150	0.82	1.00	1.00	14.1	2450	0.83	1.00	1.00	12.3	2790	0.86	1.00	1.00	10.5	3150	0.91	1.00	1.00
19.4°C	1285	15.0	2130	0.50	0.64	0.80	13.2	2440	0.48	0.63	0.82	11.4	2770	0.44	0.63	0.85	9.5	3130	0.39	0.62	0.88
	1605	16.0	2150	0.55	0.72	0.93	14.2	2450	0.53	0.72	0.96	12.3	2790	0.51	0.72	1.00	10.3	3150	0.48	0.73	1.00
	1925	16.8	2160	0.59	0.79	1.00	14.9	2470	0.59	0.81	1.00	12.9	2800	0.57	0.84	1.00	10.9	3160	0.54	0.87	1.00
21.7°C	1285	16.6	2160	0.38	0.50	0.63	14.7	2460	0.34	0.48	0.62	12.8	2800	0.29	0.46	0.62	10.9	3160	0.22	0.42	0.61
	1605	17.6	2170	0.41	0.55	0.70	15.6	2480	0.37	0.54	0.71	13.7	2810	0.33	0.51	0.71	11.7	3180	0.27	0.50	0.72
	1925	18.3	2180	0.43	0.60	0.77	16.3	2490	0.40	0.59	0.79	14.3	2820	0.36	0.56	0.82	12.2	3190	0.30	0.56	0.84

30 KW COOLING HIGH EFFICIENCY KDB102H4 (2ND STAGE)

Entering Wet Bulb Temperature	Total Air Volume	Outdoor Air Temperature Entering Outdoor Coil																			
		26.7°C					35°C					43.3°C					51.7°C				
		Total Cool Cap.	Comp. Motor Input	Sensible To Total Ratio (S/T)			Total Cool Cap.	Comp. Motor Input	Sensible To Total Ratio (S/T)			Total Cool Cap.	Comp. Motor Input	Sensible To Total Ratio (S/T)			Total Cool Cap.	Comp. Motor Input	Sensible To Total Ratio (S/T)		
				Dry Bulb					Dry Bulb					Dry Bulb					Dry Bulb		
L/s	kW	kW	24°C	27°C	29°C	kW	kW	24°C	27°C	29°C	kW	kW	24°C	27°C	29°C	kW	kW	24°C	27°C	29°C	
17.2°C	1285	25.3	4800	0.77	0.93	1.00	23.7	5440	0.78	0.96	1.00	22.0	6170	0.80	0.99	1.00	20.3	7030	0.83	1.00	1.00
	1605	26.6	4810	0.83	1.00	1.00	25.1	5440	0.86	1.00	1.00	23.6	6170	0.88	1.00	1.00	21.8	7020	0.92	1.00	1.00
	1925	28.2	4820	0.90	1.00	1.00	26.5	5440	0.93	1.00	1.00	24.8	6170	0.96	1.00	1.00	23.0	7000	1.00	1.00	1.00
19.4°C	1285	27.1	4810	0.59	0.74	0.89	25.4	5440	0.60	0.76	0.92	23.5	6170	0.61	0.78	0.95	21.6	7010	0.61	0.80	0.99
	1605	28.2	4820	0.63	0.81	0.98	26.4	5440	0.64	0.83	1.00	24.5	6170	0.65	0.86	1.00	22.4	7000	0.68	0.90	1.00
	1925	29.1	4820	0.68	0.88	1.00	27.2	5450	0.70	0.91	1.00	25.2	6160	0.70	0.94	1.00	23.1	7010	0.73	0.98	1.00
21.7°C	1285	28.8	4830	0.44	0.58	0.72	27.1	5450	0.43	0.59	0.74	25.2	6170	0.43	0.60	0.76	23.1	7020	0.43	0.61	0.78
	1605	30.0	4830	0.45	0.62	0.79	28.1	5450	0.45	0.63	0.81	26.1	6170	0.45	0.65	0.84	24.0	7000	0.45	0.66	0.87
	1925	30.8	4830	0.47	0.67	0.86	28.9	5450	0.47	0.69	0.89	26.8	6170	0.47	0.70	0.92	24.6	7010	0.48	0.73	0.96

Entering Wet Bulb Temperature	Total Air Volume	Outdoor Air Temperature Entering Outdoor Coil														
		46°C					48°C					50°C				
		Total Cool Cap.	Comp. Motor Input	Sensible To Total Ratio (S/T)			Total Cool Cap.	Comp. Motor Input	Sensible To Total Ratio (S/T)			Total Cool Cap.	Comp. Motor Input	Sensible To Total Ratio (S/T)		
				Dry Bulb					Dry Bulb					Dry Bulb		
L/s	kW	kW	24°C	27°C	29°C	kW	kW	24°C	27°C	29°C	kW	kW	24°C	27°C	29°C	
17.2°C	1285	20.3	7.01	.83	1.00	1.00	19.7	7.35	.84	1.00	1.00	19.1	7.71	.86	1.00	1.00
	1605	21.9	7.00	.92	1.00	1.00	21.2	7.34	.94	1.00	1.00	20.5	7.68	.95	1.00	1.00
	1925	23.0	6.98	1.00	1.00	1.00	22.3	7.33	1.00	1.00	1.00	21.6	7.68	1.00	1.00	1.00
19.4°C	1285	21.6	7.00	.62	.81	.99	20.9	7.35	.62	.82	1.00	20.1	7.71	.63	.83	1.00
	1605	22.5	6.98	.68	.90	1.00	21.7	7.33	.69	.92	1.00	21.0	7.69	.69	.93	1.00
	1925	23.2	7.00	.74	.98	1.00	22.4	7.33	.74	.99	1.00	21.7	7.69	.75	1.00	1.00
21.7°C	1285	23.2	7.00	.43	.61	.78	22.4	7.33	.43	.61	.80	21.6	7.69	.43	.62	.81
	1605	24.1	6.98	.46	.66	.88	23.3	7.33	.45	.68	.89	22.5	7.68	.46	.69	.91
	1925	24.7	7.00	.48	.73	.96	23.9	7.33	.48	.74	.98	23.0	7.68	.49	.76	.99

30 KW HEATING HIGH EFFICIENCY KDB102H4

Indoor Coil Air Volume 21°C Dry Bulb	Air Temperature Entering Outdoor Coil									
	18°C		7°C		-4°C		-15°C		-28°C	
	Total Heating Capacity	Comp. Motor Input	Total Heating Capacity	Comp. Motor Input	Total Heating Capacity	Comp. Motor Input	Total Heating Capacity	Comp. Motor Input	Total Heating Capacity	Comp. Motor Input
L/s	kW	kW	kW	kW	kW	kW	kW	kW	kW	kW
1285	31.5	4.88	23.3	4.98	15.1	5.07	7.5	4.85	3.9	3.53
1605	32.0	4.60	23.8	4.70	15.6	4.79	8.1	4.57	4.5	3.25
1925	32.4	4.41	24.2	4.51	16.1	4.60	8.5	4.38	4.9	3.06

BLOWER DATA

BASE UNIT

BLOWER TABLE INCLUDES RESISTANCE FOR BASE UNIT ONLY (NO HEAT SECTION) WITH DRY INDOOR COIL AND AIR FILTERS IN PLACE. FOR ALL UNITS ADD:

- 1 – Wet indoor coil air resistance of selected unit.
 - 2 – Any factory installed options air resistance (heat section, economizer, etc.)
 - 3 – Any field installed accessories air resistance (duct resistance, diffuser, etc.)
- Then determine from blower table blower motor output required.

See page 19 for blower motors and drives.

See page 19 for wet coil and option/accessory air resistance data.

MINIMUM AIR VOLUME REQUIRED FOR USE WITH GAS HEAT - Maximum Static Pressure - 500 Pa (2.0 in. w.g.)

Air Volume		TOTAL STATIC PRESSURE - Pa (Inches Water Gauge)																				
		50 (0.20)			100 (0.40)			150 (0.60)			200 (0.80)			250 (1.00)			300 (1.20)			350 (1.40)		
L/s	cfm	rev/min	kW	BHP	rev/min	kW	BHP	rev/min	kW	BHP	rev/min	kW	BHP	rev/min	kW	BHP	rev/min	kW	BHP	rev/min	kW	BHP
1062	2250	587	0.06	0.08	637	0.23	0.31	690	0.42	0.56	746	0.61	0.82	805	0.79	1.06	865	0.95	1.28	927	1.09	1.46
1180	2500	601	0.18	0.24	650	0.35	0.47	703	0.53	0.71	757	0.71	0.95	815	0.88	1.18	875	1.04	1.4	938	1.17	1.57
1298	2750	616	0.31	0.41	664	0.46	0.62	715	0.63	0.85	769	0.81	1.09	826	0.98	1.31	886	1.13	1.52	950	1.27	1.7
1416	3000	632	0.43	0.58	679	0.59	0.79	729	0.75	1.01	782	0.92	1.23	839	1.08	1.45	899	1.24	1.66	963	1.37	1.84
1534	3250	649	0.57	0.76	695	0.72	0.96	744	0.87	1.17	797	1.04	1.39	853	1.19	1.6	913	1.35	1.81	976	1.48	1.99
1652	3500	666	0.71	0.95	712	0.85	1.14	761	1.01	1.35	813	1.16	1.55	868	1.31	1.76	929	1.47	1.97	990	1.62	2.17
1770	3750	685	0.87	1.16	730	1.00	1.34	779	1.14	1.53	830	1.30	1.74	886	1.45	1.94	946	1.60	2.15	1005	1.76	2.36
1888	4000	706	1.02	1.37	750	1.16	1.55	798	1.29	1.73	849	1.44	1.93	905	1.60	2.14	965	1.75	2.35	1019	1.92	2.57
2006	4250	727	1.19	1.6	772	1.32	1.77	819	1.45	1.95	871	1.60	2.15	926	1.75	2.35	984	1.92	2.58	1034	2.09	2.8
2124	4500	750	1.37	1.84	795	1.50	2.01	843	1.63	2.19	894	1.78	2.38	949	1.93	2.59	1003	2.11	2.83	1050	2.29	3.07
2242	4750	775	1.57	2.1	820	1.69	2.26	868	1.82	2.44	919	1.96	2.63	972	2.13	2.86	1023	2.32	3.11	1067	2.51	3.36
2360	5000	802	1.77	2.37	847	1.89	2.53	895	2.02	2.71	945	2.17	2.91	997	2.36	3.16	1044	2.56	3.43	1087	2.75	3.69
2477	5250	831	1.99	2.67	876	2.11	2.83	924	2.25	3.01	973	2.41	3.23	1022	2.61	3.5	1066	2.82	3.78	1108	3.01	4.04
2595	5500	862	2.22	2.98	907	2.34	3.14	955	2.48	3.33	1002	2.68	3.59	1048	2.90	3.89	1090	3.11	4.17	1132	3.30	4.42
2713	5750	895	2.47	3.31	940	2.60	3.48	987	2.77	3.71	1032	2.99	4.01	1075	3.22	4.32	1116	3.42	4.59	1158	3.60	4.82
2831	6000	931	2.73	3.66	976	2.89	3.87	1021	3.10	4.16	1064	3.35	4.49	1104	3.57	4.78	1144	3.74	5.02	1185	3.90	5.23

Air Volume		TOTAL STATIC PRESSURE - Pa (Inches Water Gauge)																	
		400 (1.60)			450 (1.80)			500 (2.00)			550 (2.20)			600 (2.40)			650 (2.60)		
L/s	cfm	rev/min	kW	BHP	rev/min	kW	BHP	rev/min	kW	BHP	rev/min	kW	BHP	rev/min	kW	BHP	rev/min	kW	BHP
1062	2250	985	1.17	1.57	1034	1.25	1.68	1084	1.34	1.8	1136	1.45	1.95	1189	1.59	2.13	1239	1.73	2.32
1180	2500	996	1.27	1.7	1045	1.36	1.82	1095	1.46	1.96	1147	1.59	2.13	1201	1.72	2.31	1253	1.88	2.52
1298	2750	1008	1.37	1.84	1056	1.48	1.98	1105	1.59	2.13	1158	1.72	2.31	1213	1.88	2.52	1266	2.04	2.73
1416	3000	1019	1.48	1.99	1066	1.60	2.15	1115	1.73	2.32	1169	1.87	2.51	1225	2.04	2.73	1279	2.21	2.96
1534	3250	1030	1.61	2.16	1076	1.74	2.33	1126	1.88	2.52	1181	2.04	2.73	1237	2.20	2.95	1293	2.38	3.19
1652	3500	1041	1.75	2.35	1087	1.89	2.53	1138	2.04	2.73	1193	2.20	2.95	1250	2.38	3.19	1307	2.56	3.43
1770	3750	1053	1.90	2.55	1098	2.05	2.75	1150	2.21	2.96	1207	2.39	3.2	1264	2.57	3.44	1321	2.75	3.69
1888	4000	1065	2.07	2.78	1111	2.23	2.99	1164	2.40	3.22	1221	2.58	3.46	1279	2.76	3.7	1336	2.95	3.96
2006	4250	1079	2.25	3.02	1126	2.42	3.25	1180	2.60	3.49	1236	2.78	3.73	1295	2.97	3.98	1352	3.16	4.24
2124	4500	1094	2.46	3.3	1142	2.63	3.53	1196	2.81	3.77	1253	3.00	4.02	1311	3.19	4.27	1369	3.38	4.53
2242	4750	1112	2.69	3.6	1161	2.86	3.84	1215	3.04	4.08	1271	3.22	4.32	1329	3.41	4.57	1387	3.60	4.83
2360	5000	1131	2.93	3.93	1181	3.10	4.16	1235	3.28	4.4	1291	3.46	4.64	1349	3.65	4.89	1406	3.83	5.14
2477	5250	1153	3.19	4.27	1203	3.36	4.51	1256	3.54	4.74	1312	3.72	4.98	1369	3.89	5.22	1426	4.08	5.47
2595	5500	1177	3.46	4.64	1226	3.63	4.87	1278	3.80	5.09	1333	3.97	5.32	1390	4.15	5.56	---	---	---
2713	5750	1202	3.75	5.03	1251	3.91	5.24	1302	4.07	5.46	1356	4.24	5.68	---	---	---	---	---	---
2831	6000	1229	4.05	5.43	1276	4.20	5.63	---	---	---	---	---	---	---	---	---	---	---	---

BLOWER DATA

FACTORY INSTALLED BELT DRIVE KIT SPECIFICATIONS

Nominal		Maximum		Drive Kit Number	rev/min Range
kW	hp	kW	hp		
1.5	2	1.7	2.3	1	490 - 740
1.5	2	1.7	2.3	2	665 - 920
1.5	2	1.7	2.3	3	660 - 995
2.2	3	2.6	3.45	7	610 - 810
2.2	3	2.6	3.45	8	780 - 1000
2.2	3	2.6	3.45	9	845 - 1085
3.7	5	4.3	5.75	10	750 - 945
3.7	5	4.3	5.75	11	865 - 1095
3.7	5	4.3	5.75	12	940 - 1190

POWER EXHAUST FAN PERFORMANCE

Return Air System Static Pressure		Air Volume Exhausted	
Pa	in. w.g.	L/s	cfm
0	0	1498	3175
12	0.05	1394	2955
25	0.10	1267	2685
37	0.15	1137	2410
50	0.20	1022	2165
62	0.25	906	1920
75	0.30	670	1420
87	0.35	566	1200

FACTORY INSTALLED OPTIONS/FIELD INSTALLED ACCESSORY AIR RESISTANCE

Air Volume		Wet Indoor Coil		Gas Heat Exchanger						Economizer		Filters				Return Air Adaptor Plate	
				Standard Heat		Medium Heat		High Heat				MERV 8		MERV 13			
L/s	cfm	Pa	in. w.g.	Pa	in. w.g.	Pa	in. w.g.	Pa	in. w.g.	Pa	in. w.g.	Pa	in. w.g.	Pa	in. w.g.	Pa	in. w.g.
1062	2250	32	0.13	17	0.07	17	0.07	20	0.08	20	0.08	2	0.01	10	0.04	0	0.00
1180	2500	37	0.15	22	0.09	25	0.1	27	0.11	27	0.11	2	0.01	12	0.05	0	0.00
1298	2750	42	0.17	22	0.09	27	0.11	30	0.12	30	0.12	5	0.02	12	0.05	0	0.00
1416	3000	47	0.19	27	0.11	30	0.12	32	0.13	32	0.13	5	0.02	15	0.06	5	0.02
1534	3250	57	0.23	30	0.12	37	0.15	40	0.16	37	0.15	5	0.02	15	0.06	5	0.02
1652	3500	65	0.26	30	0.12	40	0.16	42	0.17	37	0.15	7	0.03	17	0.07	10	0.04
1770	3750	72	0.29	35	0.14	47	0.19	50	0.2	37	0.15	7	0.03	20	0.08	17	0.07
1888	4000	77	0.31	35	0.14	52	0.21	55	0.22	47	0.19	10	0.04	20	0.08	22	0.09
2006	4250	85	0.34	35	0.14	60	0.24	70	0.28	47	0.19	10	0.04	22	0.09	27	0.11
2124	4500	92	0.37	37	0.15	65	0.26	80	0.32	55	0.22	10	0.04	22	0.09	30	0.12
2242	4750	99	0.4	40	0.16	72	0.29	92	0.37	62	0.25	12	0.05	25	0.1	40	0.16
2360	5000	107	0.43	40	0.16	85	0.34	107	0.43	72	0.29	15	0.06	25	0.1	45	0.18
2477	5250	114	0.46	40	0.16	92	0.37	117	0.47	80	0.32	15	0.06	27	0.11	47	0.19
2595	5500	124	0.5	45	0.18	109	0.44	134	0.54	85	0.34	17	0.07	30	0.12	55	0.22
2713	5750	139	0.56	47	0.19	122	0.49	147	0.59	112	0.45	17	0.07	30	0.12	62	0.25
2831	6000	147	0.59	50	0.2	134	0.54	159	0.64	129	0.52	20	0.08	32	0.13	67	0.27

BLOWER DATA

CEILING DIFFUSERS AIR RESISTANCE

Unit Size	RTD11 Step-Down Diffuser								FD11 Flush Diffuser	
	Air Volume		2 Ends Open		1 Side, 2 Ends Open		All Ends & Sides Open			
	Pa	in. w.g.	Pa	in. w.g.	Pa	in. w.g.	Pa	in. w.g.	Pa	in. w.g.
092 Models	1133	2400	52	0.21	45	0.18	37	0.15	35	0.14
	1227	2600	60	0.24	52	0.21	45	0.18	42	0.17
	1321	2800	67	0.27	60	0.24	52	0.21	50	0.20
	1416	3000	80	0.32	72	0.29	62	0.25	62	0.25
	1510	3200	102	0.41	92	0.37	80	0.32	77	0.31
	1604	3400	124	0.50	112	0.45	97	0.39	92	0.37
	1699	3600	152	0.61	134	0.54	119	0.48	109	0.44
1793	3800	182	0.73	157	0.63	142	0.57	127	0.51	
102 Models	1699	3600	90	0.36	70	0.28	57	0.23	37	0.15
	1793	3800	99	0.40	80	0.32	65	0.26	45	0.18
	1888	4000	109	0.44	90	0.36	72	0.29	52	0.21
	1982	4200	122	0.49	99	0.40	82	0.33	60	0.24
	2076	4400	134	0.54	109	0.44	92	0.37	67	0.27
	2171	4600	149	0.60	122	0.49	104	0.42	77	0.31
	2265	4800	162	0.65	132	0.53	114	0.46	87	0.35
	2360	5000	172	0.69	144	0.58	124	0.50	97	0.39
2454	5200	186	0.75	154	0.62	134	0.54	107	0.43	

CEILING DIFFUSER AIR THROW DATA

Model No.	Air Volume		¹ Effective Throw Range			
			RTD11 Step-Down		FD11 Flush	
	L/s	cfm	m	ft.	m	ft.
092 Models	1227	2600	7 - 9	24 - 29	6 - 7	19 - 24
	1321	2800	8 - 9	25 - 30	6 - 9	20 - 28
	1416	3000	8 - 10	27 - 33	6 - 9	21 - 29
	1510	3200	9 - 11	28 - 35	7 - 9	22 - 29
	1604	3400	9 - 11	30 - 37	7 - 9	22 - 30
102 Models	1699	3600	8 - 10	25 - 33	7 - 9	22 - 29
	1793	3800	8 - 11	27 - 35	7 - 9	22 - 30
	1888	4000	9 - 11	29 - 37	7 - 10	24 - 33
	1982	4200	10 - 12	32 - 40	8 - 11	26 - 35
	2076	4400	10 - 13	34 - 42	9 - 11	28 - 37

¹ Throw is the horizontal or vertical distance an air stream travels on leaving the outlet or diffuser before the maximum velocity is reduced to 15 m (50 ft.) per minute. Four sides open.

ELECTRICAL DATA

		KDB092H4			KDB102H4		
¹ Voltage - 50Hz 3 Phase with neutral		380/420V			380/420V		
Compressor 1	Rated Load Amps	6.1			6.3		
	Locked Rotor Amps	41			55		
Compressor 2	Rated Load Amps	6.1			6.3		
	Locked Rotor Amps	41			55		
Outdoor Fan Motors	Full Load Amps	(2) 2.8			(2) 2.8		
	(total)	5.6			5.6		
Power Exhaust (1) 0.25 kW (0.33 HP)	Full Load Amps	1.3			1.3		
Indoor Blower Motor	kW	1.5	2.2	3.7	1.5	2.2	3.7
	Full Load Amps	3.6	5.3	8.2	3.6	5.3	8.2
² Maximum Overcurrent Protection	Unit Only	25	30	35	25	30	35
	With 0.25 kW (0.33 HP) Power Exhaust	30	30	35	30	30	35
³ Minimum Circuit Ampacity	Unit Only	23	25	29	24	26	29
	With 0.25 kW (0.33 HP) Power Exhaust	25	26	30	25	27	30

¹ Extremes of operating range are plus and minus 10% of line voltage.

² Heating / Air Conditioning / Refrigeration (HACR) type breaker or fuse.

³ Refer to local codes to determine wire, fuse and disconnect size requirements.

UNIT CLEARANCES

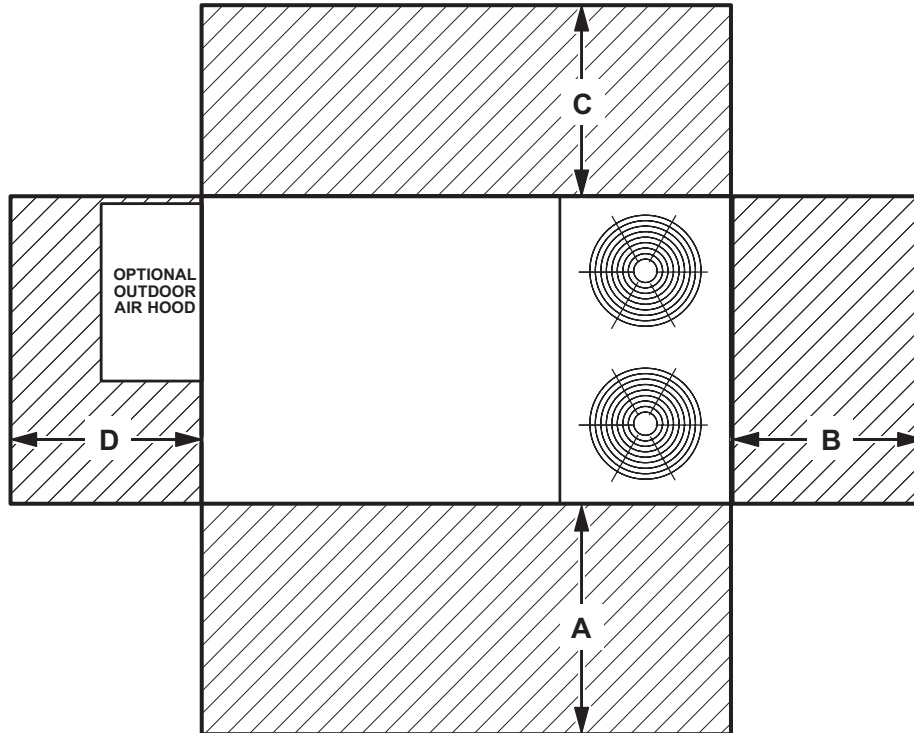

¹ Unit Clearance	A		B		C		D		Top Clearance
	mm	in.	mm	in.	mm	in.	mm	in.	
Service Clearance	1524	60	914	36	914	36	1524	60	Unobstructed
Minimum Operation Clearance	914	36	914	36	914	36	914	36	

NOTE - Entire perimeter of unit base requires support when elevated above the mounting surface.

¹ Service Clearance - Required for removal of serviceable parts.

Minimum Operation Clearance - Required clearance for proper unit operation.

OUTDOOR SOUND DATA

Unit Model Number	Octave Band Sound Power Levels dBA, re 10 ⁻¹² Watts Center Frequency - Hz							¹ Sound Rating Number (dBA)
	125	250	500	1000	2000	4000	8000	
KDB092, 102	72	75	76	73	67	60	50	86

Note - The octave sound power data does not include tonal corrections.

¹ Sound Rating Number according to AHRI Standard 270-95 or AHRI Standard 370-2001 (includes pure tone penalty). Sound Rating Number is the overall A-Weighted Sound Power Level, (LWA), dBA (100 Hz to 10,000 Hz).

WEIGHT DATA

Model Number	Net		Shipping	
	kg	lbs.	kg	lbs.
KDB092H Base Unit	487	1073	526	1158
KDB092H Max. Unit	569	1253	608	1340
KDB102H Base Unit	488	1075	527	1160
KDB102H Max. Unit	570	1255	608	1340

OPTIONS / ACCESSORIES

Model Number	Shipping Weight	
	kg	lbs.

ECONOMIZER / OUTDOOR AIR / EXHAUST**Economizer**

Economizer Dampers	27	60
Barometric Relief Dampers (downflow)	4	8
Barometric Relief Damper Hood (downflow)	11	25
Outdoor Air Hood (downflow)	10	23

Outdoor Air Dampers

Outdoor Air Damper Section (downflow) - Automatic	4	9
Outdoor Air Damper Section (downflow) - Manual	1	2
Outdoor Air Damper Hood (downflow)	4	9

Power Exhaust

	14	31
--	----	----

GAS HEAT EXCHANGER (NET WEIGHT)

Medium Heat (add over standard heat)	5	9
High Heat (add over standard heat)	15	32

ROOF CURBS**Hybrid Roof Curbs, Downflow**

203 mm height	27	60
356 mm height	39	85
457 mm height	45	100
610 mm height	57	125

Adjustable Pitch Curb, Downflow

356 mm height	82	191
---------------	----	-----

CEILING DIFFUSERS**Step-Down**

RTD11-95S	118	54
RTD11-135S	135	61

Flush

FD11-95S	118	54
FD11-135S	135	61

Transitions

C1DIFF30B-1	14	30
C1DIFF31B-1	15	32

PACKAGING

LTL Packaging (less than truck load)	48	105
--------------------------------------	----	-----

DIMENSIONS

UNIT

Model No.	CORNER WEIGHTS														CENTER OF GRAVITY									
	AA				BB				CC				DD				EE				FF			
	Base		Max.		Base		Max.		Base		Max.		Base		Max.		Base		Max.		Base		Max.	
	kg	lbs.	kg	lbs.	kg	lbs.	kg	lbs.	kg	lbs.	kg	lbs.	kg	lbs.	mm	in.	mm	in.	mm	in.	mm	in.	mm	in.
KDB092	129	283	150	331	108	237	126	277	113	249	132	290	138	304	161	355	1118	44	1092	43	686	27	711	28
KDB102	129	284	151	332	108	237	126	277	113	249	132	291	138	304	161	355	1118	44	1092	43	686	27	711	28

Std. Unit - The unit with NO INTERNAL OPTIONS.

Max. Unit - The unit with ALL INTERNAL OPTIONS Installed. (Economizer, Standard Static Power Exhaust Fans, Controls, etc.). Does not include accessories external to unit or high static power exhaust.

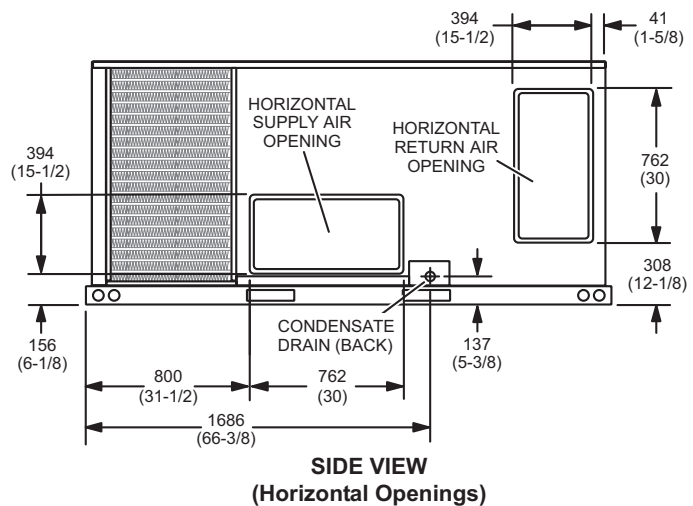
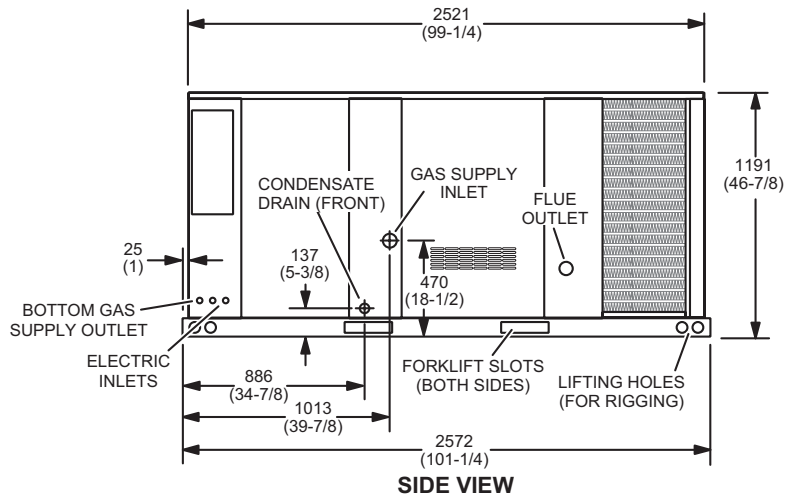
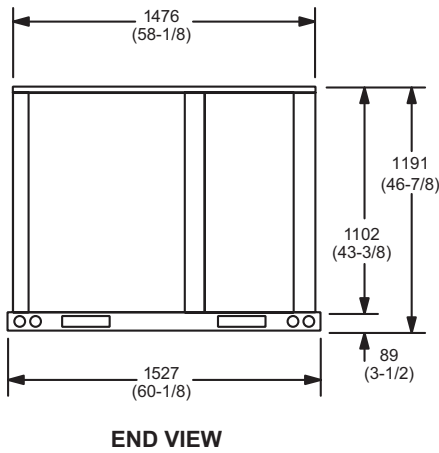
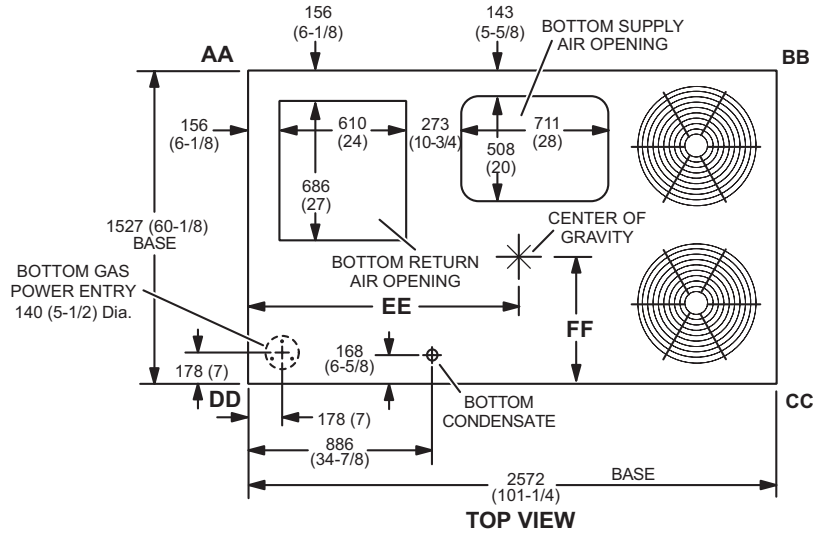

UNIT ON CURB LOCATION - KDB122

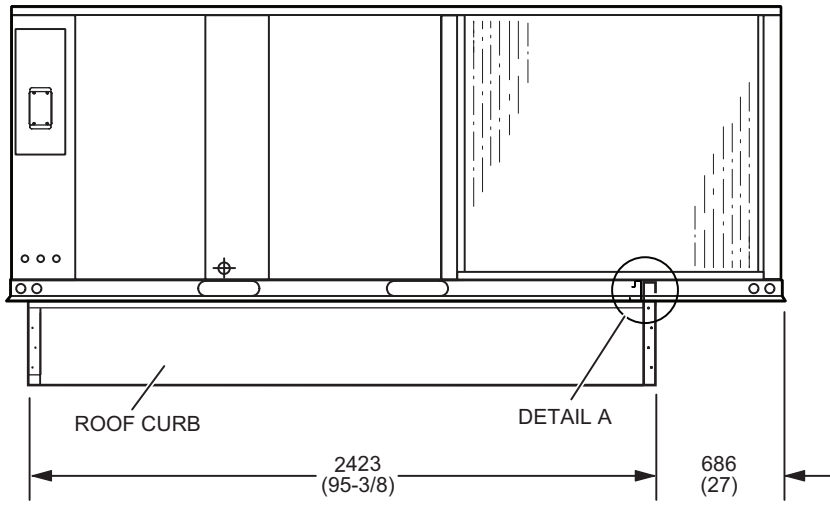

SIDE VIEW

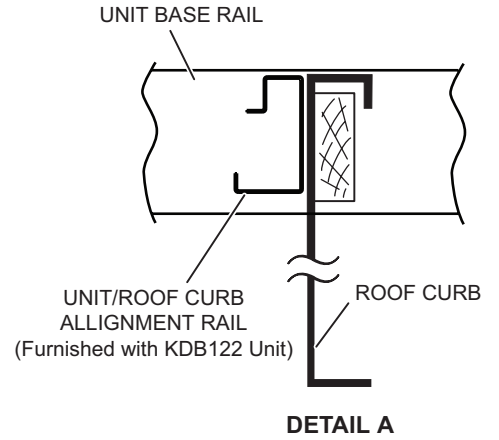

DETAIL A

NOTE - Unit cannot be installed on a full perimeter curb!

OUTDOOR AIR HOOD DETAIL

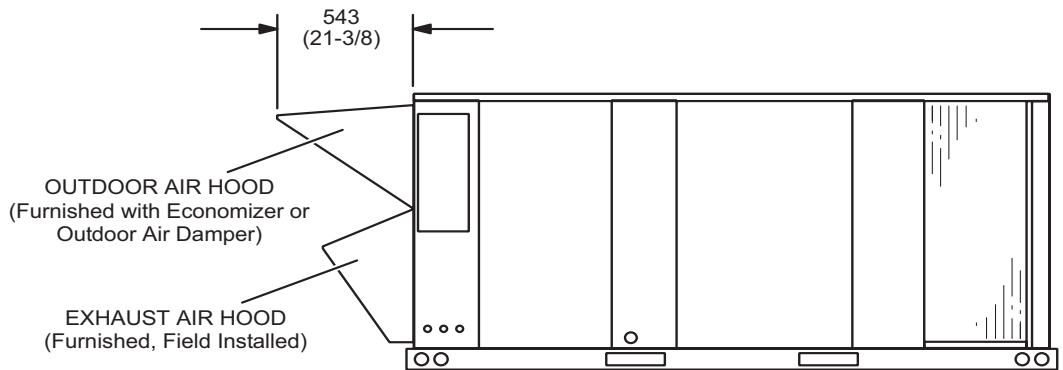

HORIZONTAL ECONOMIZER APPLICATION

(With Furnished Barometric Relief Dampers and Optional Horizontal Discharge Kit - Required)

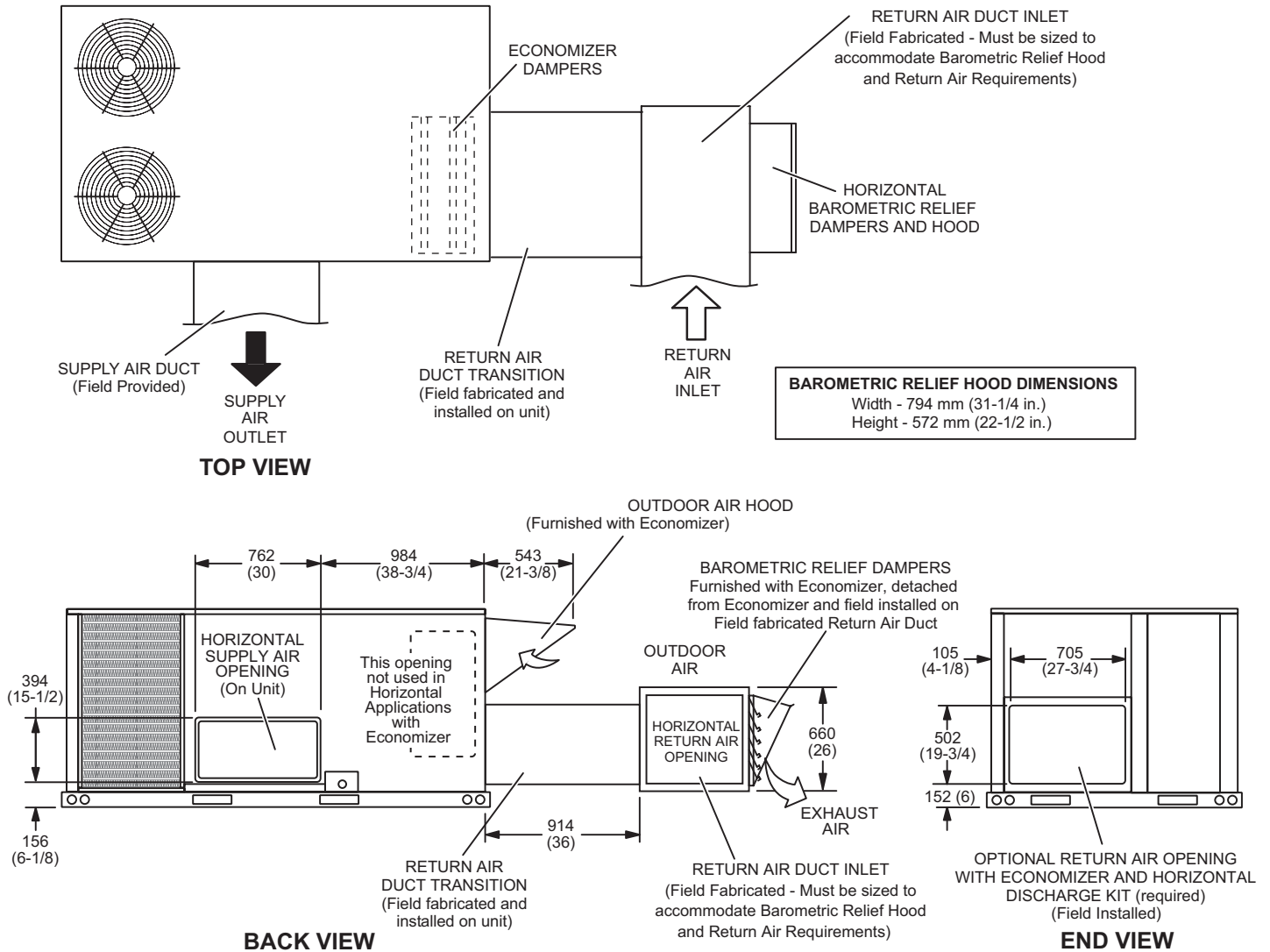

NOTE - Return Air Duct and Transition must be supported.

**BAROMETRIC RELIEF DAMPERS
(Furnished with Economizer)**

(Field installed in horizontal return air duct adjacent to unit)

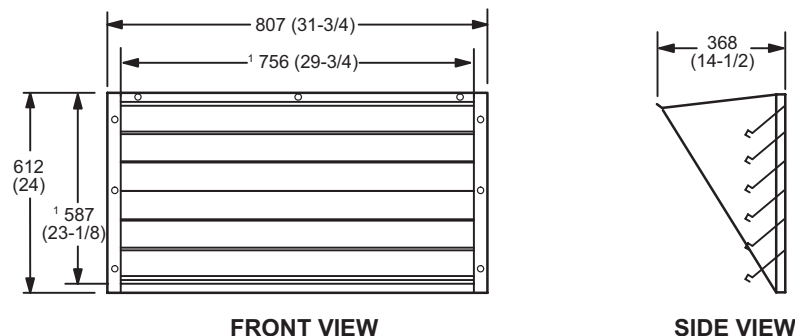

¹ NOTE - Opening size required in return air duct

HORIZONTAL ECONOMIZER APPLICATION

(with Optional Low Profile Horizontal Barometric Relief Dampers and Horizontal Discharge Kit - Required)

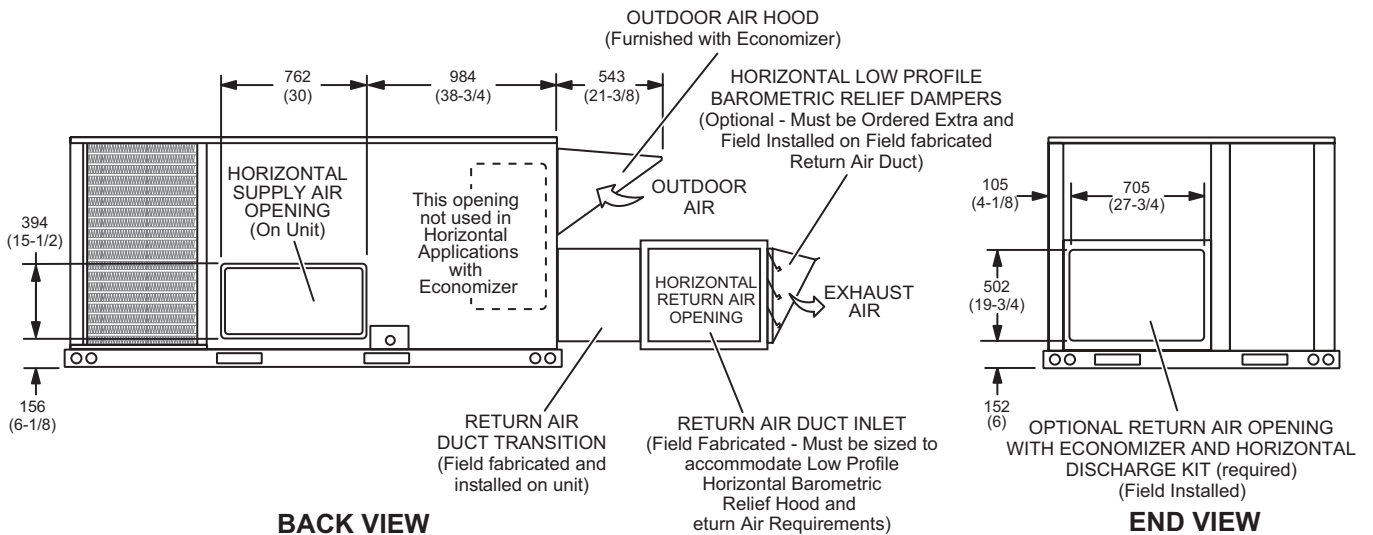
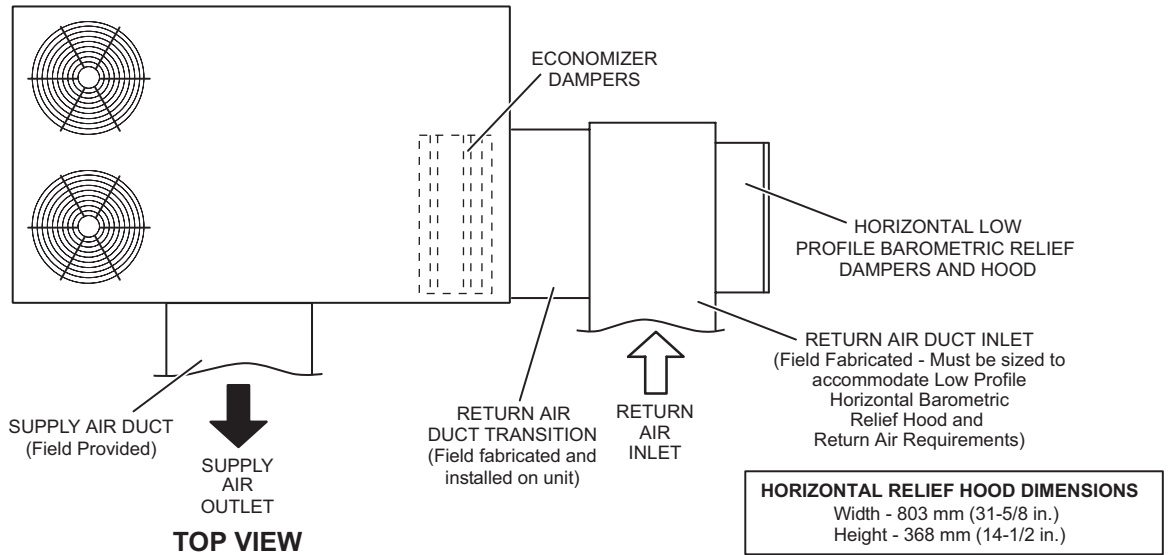

NOTE - Return Air Duct and Transition must be supported.

HORIZONTAL LOW PROFILE BAROMETRIC RELIEF DAMPERS
 (Field installed in horizontal return air duct adjacent to unit)

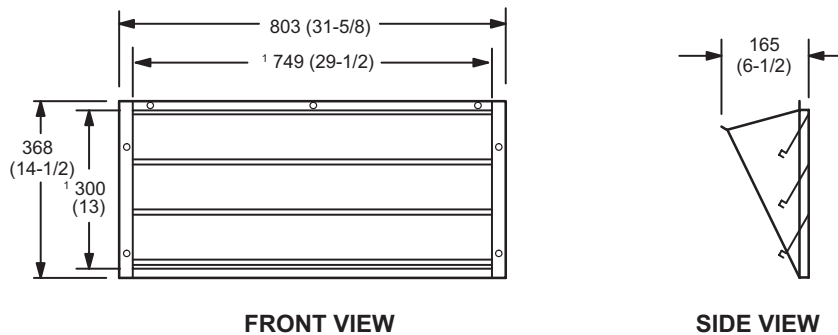

¹ NOTE - Opening size required in return air duct.

HYBRID ROOF CURBS - DOUBLE DUCT OPENING

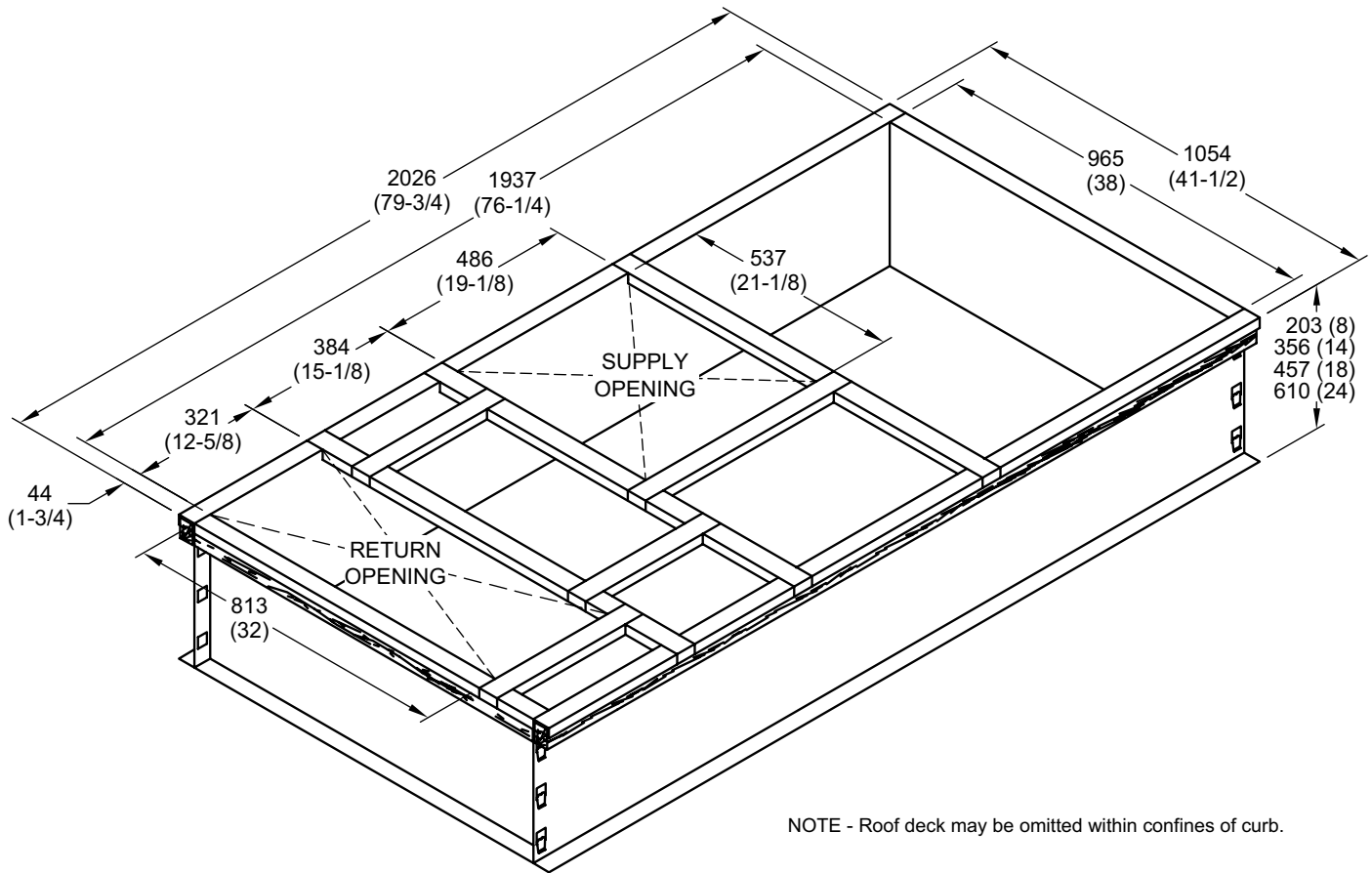

NOTE - Roof deck may be omitted within confines of curb.

TYPICAL FLASHING DETAIL FOR ROOF CURB

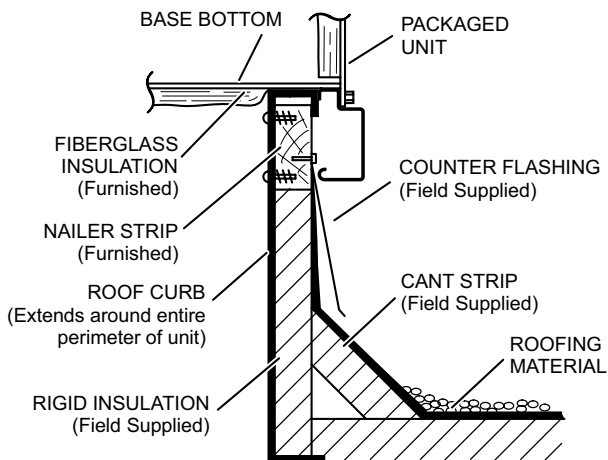

DETAIL ROOF CURB

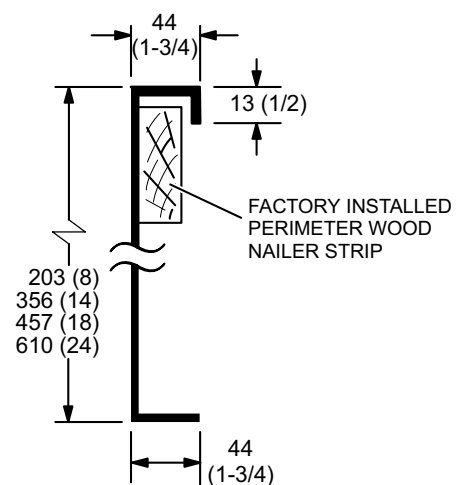

ADJUSTABLE PITCH CURBS - DOUBLE DUCT OPENING

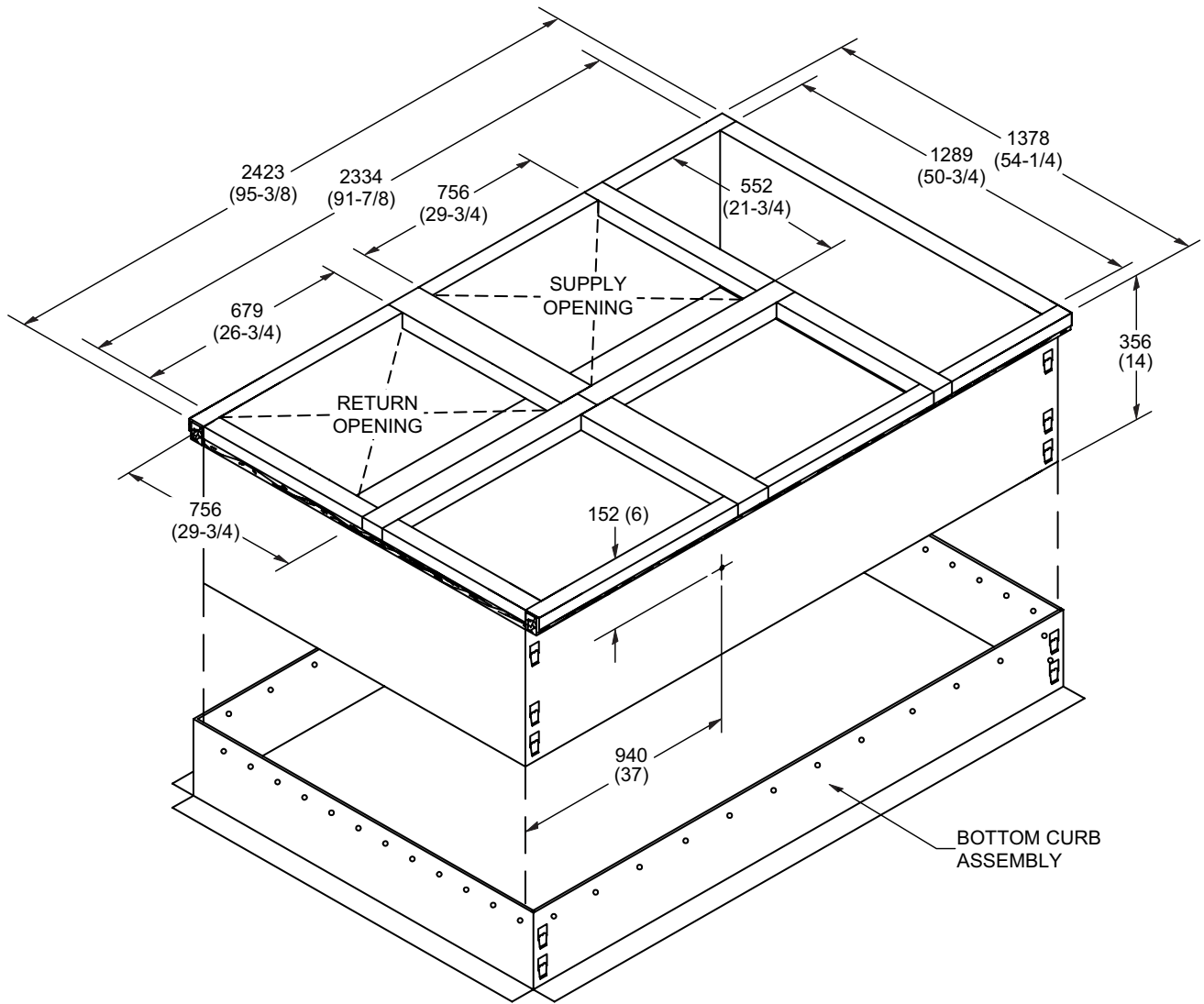

NOTE - Maximum slope pitch is 19 mm per 305 mm (3/4 in. per 1 foot) in any one direction.

TYPICAL FLASHING DETAIL FOR ROOF CURB

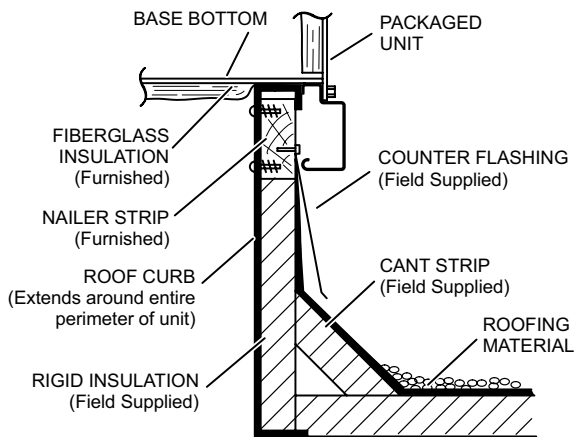

DETAIL ROOF CURB

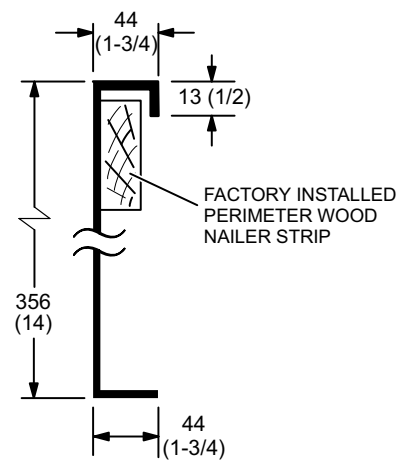

ROOF CURBS WITH SUPPLY & RETURN AIR TRANSITIONS FOR CEILING DIFFUSERS

C1DIFF30B-1 ROUND TRANSITIONS
(for 092 models)

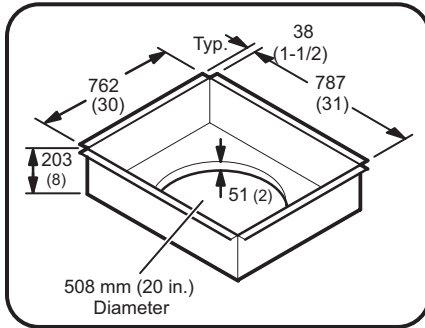

C1DIFF31B-1 & C1DIFF32B-1 RECTANGULAR TRANSITIONS
(for 102 thru 150 models)

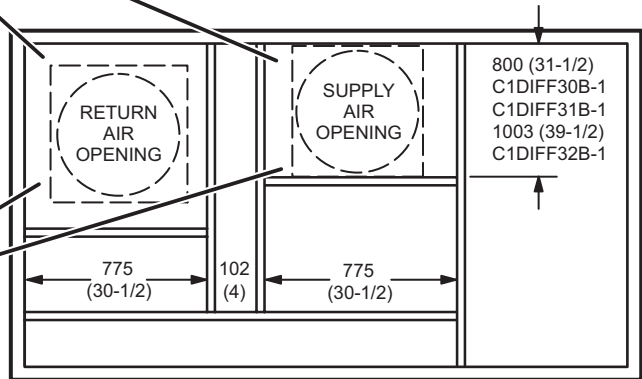
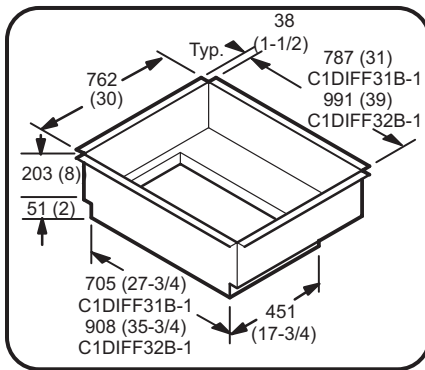

TOP VIEW

COMBINATION CEILING SUPPLY AND RETURN DIFFUSERS

STEP-DOWN CEILING DIFFUSER

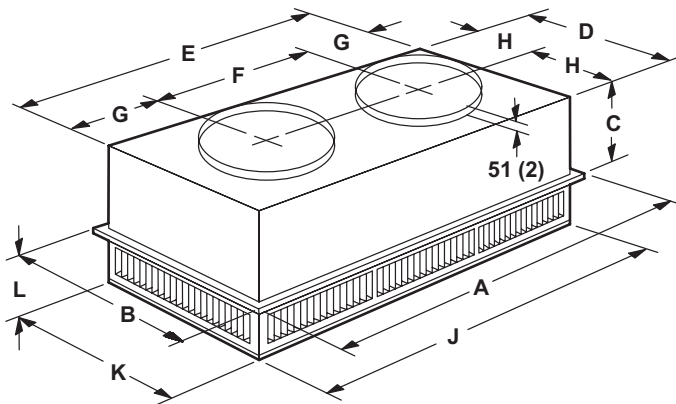

FLUSH CEILING DIFFUSER

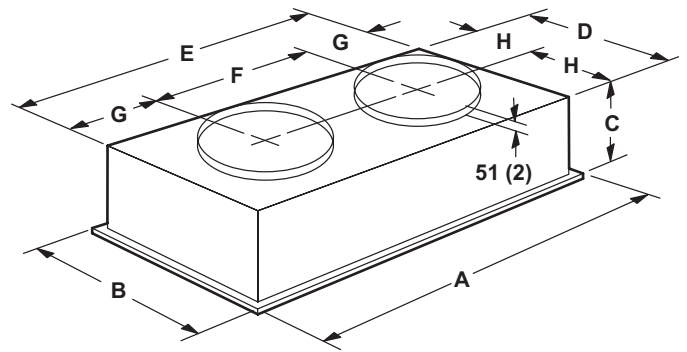

Model Number		RTD11-95S
A	mm	1159
	in.	47-5/8
B	mm	752
	in.	29-5/8
C	mm	365
	in.	14-3/8
D	mm	699
	in.	27-1/2
E	mm	1158
	in.	45-1/2
F	mm	572
	in.	22-1/2
G	mm	292
	in.	11-1/2
H	mm	349
	in.	13-3/4
J	mm	1156
	in.	45-1/2
K	mm	699
	in.	27-1/2
L	mm	206
	in.	8-1/8
Duct Size	mm	508 round
	in.	20 round

Model Number		FD11-95S
A	mm	1159
	in.	47-5/8
B	mm	752
	in.	29-5/8
C	mm	422
	in.	16-5/8
D	mm	686
	in.	27
E	mm	1143
	in.	45
F	mm	22-1/2
	in.	572
G	mm	286
	in.	11-1/4
H	mm	343
	in.	13-1/2
Duct Size	mm	508 round
	in.	20 round

COMBINATION CEILING SUPPLY AND RETURN DIFFUSERS

STEP-DOWN CEILING DIFFUSER

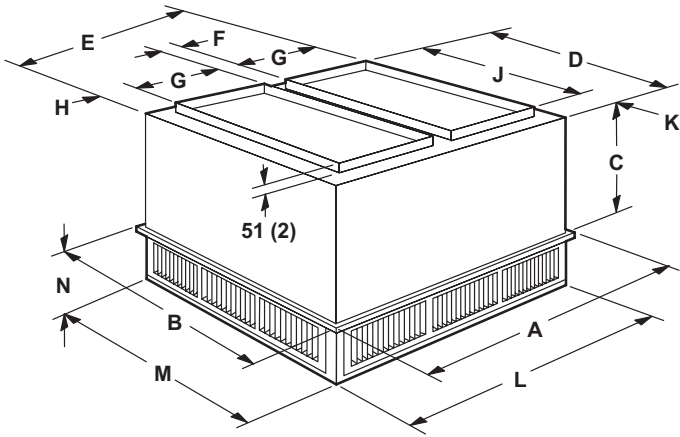

FLUSH CEILING DIFFUSER

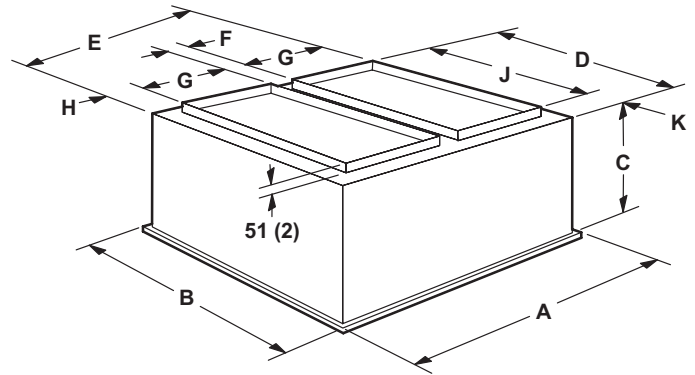

Model Number		RTD11-135S
A	mm	1210
	in.	47-5/8
B	mm	905
	in.	35-5/8
C	mm	524
	in.	20-5/8
D	mm	851
	in.	33-1/2
E	mm	1156
	in.	45-1/2
F	mm	114
	in.	4-1/2
G	mm	457
	in.	18
H	mm	64
	in.	2-1/2
J	mm	711
	in.	28
K	mm	70
	in.	2-3/4
L	mm	1156
	in.	45-1/2
M	mm	851
	in.	33-1/2
N	mm	232
	in.	9-1/8
Duct Size	mm	457 x 711
	in.	18 x 28

Model Number		FD11-135S
A	mm	1210
	in.	47-5/8
B	mm	905
	in.	35-5/8
C	mm	591
	in.	23-1/4
D	mm	838
	in.	33
E	mm	1143
	in.	45
F	mm	112
	in.	4-1/2
G	mm	457
	in.	18
H	mm	57
	in.	2-1/4
J	mm	711
	in.	28
K	mm	64
	in.	2-1/2
Duct Size	mm	457 x 711
	in.	18 x 28

REVISIONS

Sections	Description of Change
Options/Accessories	High Performance Economizer information updated.



Visit us at www.Lennox.com

For the latest technical information, www.LennoxCommercial.com

Contact us at 1-800-4-LENNOX

NOTE - Due to Lennox' ongoing commitment to quality, Specifications, Ratings and Dimensions subject to change without notice and without incurring liability. Improper installation, adjustment, alteration, service or maintenance can cause property damage or personal injury. Installation and service must be performed by a qualified installer and servicing agency.

©2022 Lennox Industries, Inc.