



KHA072

Landmark® Rooftop Units
Standard Efficiency - 50 Hz

Bulletin No. 490187
March 2021
Supersedes January 2019

**COMMERCIAL
PRODUCT SPECIFICATIONS**



LANDMARK®
Performance Marked by Flexibility™

21 kW (6 Tons)
Net Cooling Capacity - 9.0 to 17.4 kW (30 600 to 59 300 Btuh)
Net Heating Capacity - 9.6 to 18.4 kW (32 700 to 63 000 Btuh)
Optional Electric Heat - 5.7 to 23 kW

MODEL NUMBER IDENTIFICATION

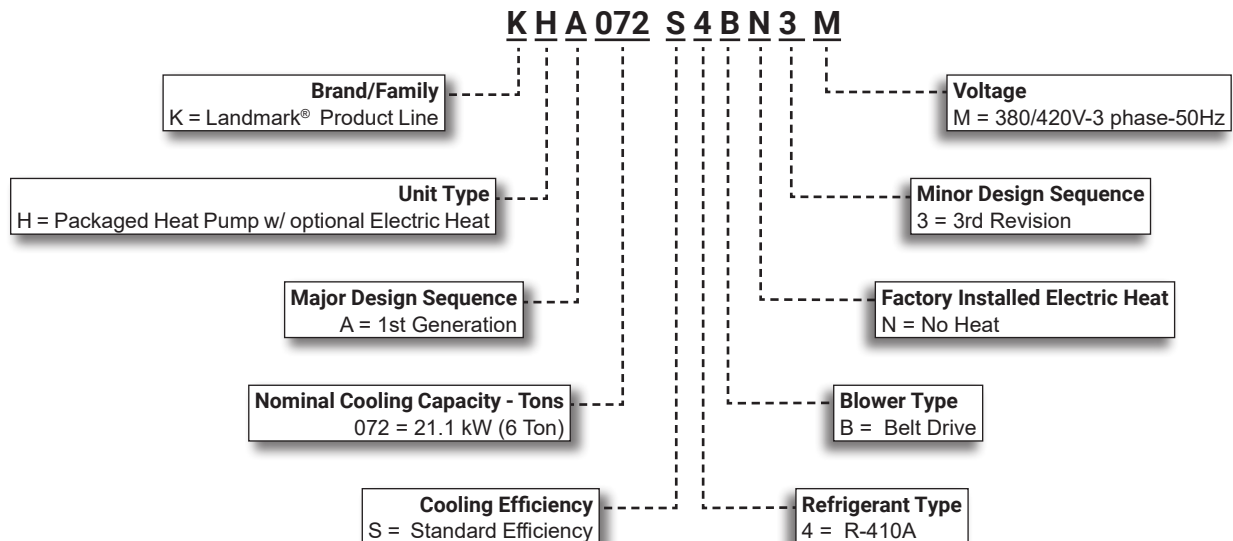

FEATURE HIGHLIGHTS

Landmark® rooftop units from Lennox are the new standard for reliable, efficient rooftop units built for long-lasting performance that can significantly improve indoor environments.

1. Single Speed Scroll Compressor
2. Check/Thermal Expansion Valve
3. Coil Construction
4. Outdoor Coil Fan Motor
5. Construction
6. Power Entry
7. Exterior Panels
8. Insulation
9. Hinged Access Panels
10. Blower
11. Electric Heat
12. Economizer
13. Power Exhaust Fan

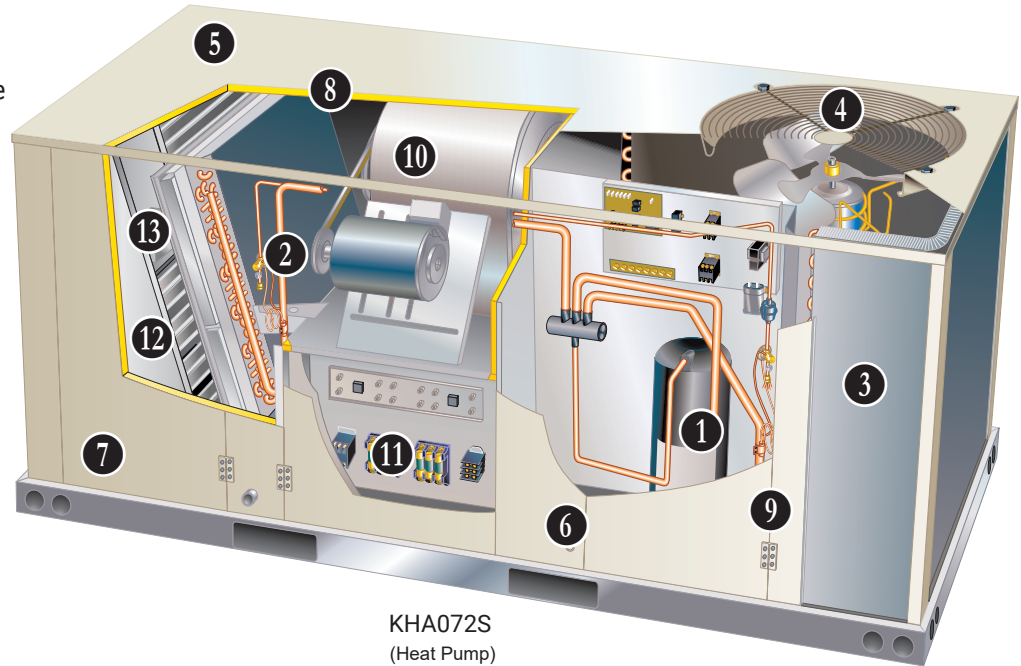

KHA072S
(Heat Pump)

Shown With Optional Electric Heat, Economizer, Power Exhaust and Hinged Access Panels

CONTENTS

Blower Data - Belt Drive - Kha072 - Downflow	13
Cooling / Heating Ratings	12
Dimensions - Accessories	20
Dimensions - Unit	19
Electrical / Electric Heat Data	16
Electric Heat Capacities	16
Features And Benefits	3
Model Number Identification.	1
Optional Conventional Temperature Control Systems	8
Options / Accessories	9
Outdoor Sound Data	17
Specifications	11
Unit Clearances	17
Weight Data	18

PERFORMANCE/QUALITY AND CE MARK OPTION

PERFORMANCE

- Components bonded for grounding to meet safety standards for servicing required by Underwriters Laboratories (UL) and the International Electrotechnical Commission (IEC)
- Cooling performance is rated at test conditions included in Air-Conditioning, Heating and Refrigeration Institute (AHRI) Standard 340/360-2007 while operating at rated voltage and air volumes
- International Organization for Standardization (ISO) 9001 Registered Manufacturing Quality System

CE MARK OPTION

- The CE mark has been added to our rooftop product line as a configure to order (CTO) option. This optional construction allows units to be sold into countries requiring CE marking for rooftop products
- CE marked units meet the requirements of the Machinery Directive 2006/42/EC, Low Voltage Directive 73/23/EEC, EMC Directive 89/336/EEC, and Gas Directive 90/396/EEC. Declaration of conformity certificates will be provided for each CE marked unit on demand
- Key features of this over and above standard product features are:
 - Touch-proof electrical components meeting the requirements of EN 60529
 - Branch circuits over 0.5 kW load have overcurrent protection
 - Rotary style/finger safe disconnect switch with locking handle prevents disconnect door from being opened with the power on. Padlock can be applied to lock the disconnect switch in the OFF position
 - The factory wiring has been redesigned for separation of high and low voltage circuits



FEATURES AND BENEFITS

COOLING SYSTEM

- Designed to maximize sensible and latent cooling performance at design conditions
- System can operate from -1°C to 52°C without any additional controls

R-410A Refrigerant

- Non-chlorine
- Ozone friendly

1 Single Speed Scroll Compressor

- Scroll compressors for high performance, reliability and quiet operation
- Resiliently mounted on rubber grommets for quiet operation

Compressor Crankcase Heater

- Protects against refrigerant migration that can occur during low ambient operation

2 Check/Thermal Expansion Valve

- Ensures optimal performance throughout the application range
- Removable element head

High Pressure Switch

- Protects the system from high pressure conditions

Reversing Valves

- 4-way interchange reversing valve effects a rapid change in direction of refrigerant flow resulting in quick changeover from cooling to heating and vice versa

Defrost Control

- Control furnished as standard
- Gives a demand defrost cycle whenever system heating performance falls below optimum levels

- Sensing element on coil determines when defrost cycle is required and when to terminate cycle
- Anti-short cycle (5 minutes) incorporated into the board
- Diagnostic LEDs furnished as an aid in troubleshooting

Filter/Drier

- High capacity filter/drier protects the system from dirt and moisture

Freezestat

- Protects the evaporator coil from damaging ice build-up due to conditions such as low/no air flow, or low refrigerant charge

3 Coil Construction

- Copper tube construction
- Enhanced rippled-edge aluminum fins
- Flared shoulder tubing connections
- Silver soldered construction
- Factory leak tested

Indoor Coil

- Cross row circuiting
- Rifled copper tubing optimizes both sensible and latent cooling capacity

Condensate Drain Pan

- Plastic pan, sloped to meet drainage requirements of American Society of Heating Refrigeration and Air Conditioning Engineers 62.1
- Side or bottom drain connections.
- Reversible to allow connection at back of unit

FEATURES AND BENEFITS

COOLING SYSTEM (continued)

- 4 Outdoor Coil Fan Motor**
- Thermal overload protected
 - Totally enclosed
 - Permanently lubricated sleeve bearing (standard efficiency)
 - Permanently lubricated ball bearings (high efficiency)
 - Shaft up
 - Wire basket mount

Outdoor Coil Fan

- Polyvinyl chloride (PVC) coated fan guard furnished

Required Selections

Cooling Capacity

- Specify nominal cooling capacity

Options / Accessories

Field Installed

Condensate Drain Trap

- Field installed only
- Available in copper or polyvinyl chloride (PVC)

Drain Pan Overflow Switch

- Monitors condensate level in drain pan, shuts down unit if drain becomes clogged

Low Ambient Kit

- Cycles the outdoor fan while allowing compressor operation in the cooling cycle
- This intermittent fan operation allows the system to operate without icing the evaporator coil and losing capacity
- Designed for use in ambient temperatures no lower than -18°C

CABINET

5 Construction

- Heavy-gauge steel panels
- Two-layer enamel paint finish
- Full perimeter heavy-gauge galvanized steel base rail
- Base rails have rigging holes
- Three sides of the base rail have fork slots
- Raised edges around duct and power entry openings in the bottom of the unit for water protection

Airflow Choice

- Units are shipped in downflow (vertical) configuration
- Can be field converted to horizontal air flow configuration without the need of a kit

6 Power Entry

- Electrical lines can be brought through the unit base or through horizontal access knock-outs

7 Exterior Panels

- Constructed of heavy-gauge, galvanized steel with a two-layer enamel paint finish

8 Insulation

- Fully insulated with non-hygroscopic fiberglass insulation (conditioned areas)
- Unit base is fully insulated
- Base insulation serves as an air seal to the roof curb, eliminating the need to add a seal during installation

Access Panels

- Economizer/Filter section
- Heating/Blower section
- Compressor/Controls section

NOTE - Include a filler panel for proper cabinet fit for optional accessories (Economizers, Power Exhaust, Outdoor Air Dampers and Barometric Relief Dampers).

Options / Accessories

Factory Installed

Corrosion Protection

- Completely flexible immersed coating
- Electrodeposited dry film process
- AST ElectroFin E-Coat
- Meets Mil Spec MIL-P-53084, ASTM B117 Standard Method Salt Spray Testing
- Indoor Corrosion Protection:
 - Coated coil
 - Painted blower housing
 - Painted base
- Outdoor Corrosion Protection:
 - Coated coil
 - Painted outdoor base

9 Hinged Access Panels

- Economizer/Filter section
- Heating/Blower section
- Compressor/Controls section
- Panel seals and quarter-turn latching handles provide a tight air and water seal

Field Installed

Combination Coil/Hail Guards

- Heavy gauge steel frame
- Painted to match cabinet
- Expanded metal mesh protects outdoor coil

FEATURES AND BENEFITS

CONTROLS

Unit Control

- All control voltage is provided via a 24V (secondary) transformer with built-in circuit breaker protection
- Up to 2 heat / 2 cool staging with a third party DDC control system or thermostat
- Low voltage terminal block provides screw terminal connections for thermostat or controller wiring
- Night Setback Mode saves energy by closing outdoor air dampers and operating supply fan on thermostat demand only

Options / Accessories

Field Installed

Smoke Detector

- Photoelectric type
- Installed in supply air section, return air section or both sections
- Available with power board and single sensor (supply or return) or power board and two sensors (supply and return)
- Power board located in unit control compartment

Thermostats

- Control system and thermostat options, see page 27
- Aftermarket unit controller options, see Options/ Accessories table

BLOWER

- 10** A wide selection of supply air blower options are available to meet a variety of air flow requirements

Motor

- Overload protected
- Ball bearings
- Two-Speed belt drive motors (low static/high static) are available on all model in several different sizes to maximize air performance

Supply Air Blower

- Forward curved blades
- Blower wheel is statically and dynamically balanced
- Belt drive motors have adjustable pulley for speed change

Ordering Information

- Specify drive kit number when base unit is ordered

Required Selections

- Order belt drive blower. (See Blower Data Table for specifications)
- Order drive kit, see Drive Kit Specifications Table

INDOOR AIR QUALITY

Air Filters

- Disposable 51 mm filters furnished as standard

Options / Accessories

Field Installed

Healthy Climate® UVC Germicidal Lamps

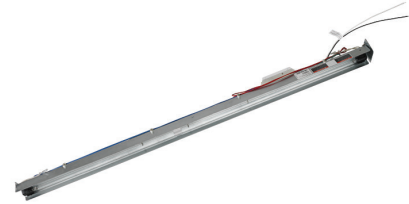

- Germicidal lamps emit ultra-violet (UV-C) energy, which has been proven to be effective in reducing microbes such as viruses, bacteria, yeasts, and molds
- This process either destroys the organism or controls its ability to reproduce
- UV-C energy greatly reduces the growth and proliferation of mold and other bioaerosols (bacteria and viruses) on illuminated surfaces (particularly coil and drain pan)
- Field installed in the blower/evaporator coil section
- Magnetic safety interlock terminates power when access panels are removed
- All necessary hardware for installation is included
- Lamps operate on 220V-1ph power supply

NOTE - Step-down transformer must be field supplied for field installation for 380/420V primary to 220V secondary.

ELECTRICAL

Marked & Color-Coded Wiring

- All electrical wiring is color-coded and marked to identify which components it is connecting

Electrical Plugs

- Positive connection electrical plugs are used to connect common accessories or maintenance parts for easy removal or installation

Required Selections

Voltage Choice

- Specify when ordering base unit

Options / Accessories

Field Installed

- 11** Electric Heat
- Helix wound nichrome elements
 - Individual element limit controls
 - Wiring harness
 - Unit fuse block
 - See Options / Accessories tables for ordering information

ECONOMIZER

Factory or Field Installed

12 Economizer (Standard and High Performance Common Features)

- Combination Outdoor Air Hood is furnished
- Factory installed Economizer can be ordered with two exhaust options:
 - Barometric Relief Dampers
 - No Exhaust
- Field installed Economizer includes Barometric Relief Dampers with Combination Hood
- Barometric Relief Dampers allow relief of excess air, dampers prevent blow back and outdoor air infiltration during off cycle, bird screen furnished

NOTE - Barometric Relief Dampers are required when Economizer is factory installed with field installed Power Exhaust Fan option. See Power Exhaust Fan section and Options/Accessories table.

- Occupied/Unoccupied mode with field furnished setback thermostat
- Demand Control Ventilation (DCV) ready using optional CO₂ sensors
- Mixed Air Sensor is furnished for field installation in the rooftop unit

NOTE - Sensor is factory installed when Economizers are factory installed.

- Single sensible sensor is furnished with Economizer and enables economizer operation if the outdoor temperature is less than the setpoint of the control
- Horizontal Barometric Dampers are required for horizontal Economizer applications and must be ordered separately

Standard Economizer Features

Gear-driven action

- Return air and outdoor air dampers
- Plug-in connections to unit
- Neoprene seals
- 24-volt, fully-modulating spring return motor

Standard Economizer Control Module

- Standard Economizer Control Module can be adjusted to operate based on outdoor air temperatures



Economizer Controls:

- **Damper Minimum Position** - Can be set lower than traditional minimum air requirements resulting in cost savings
- **IAQ Sensor** - Signals dampers to modulate and maintain 13°C when CO₂ is higher than the CO₂ setpoint
- **Demand Control Ventilation (DCV) LED** - A steady green Demand Control Ventilation LED indicates the IAQ reading is higher than setpoint and requires more fresh air
- **Free Cool LED** - A steady green LED indicates outdoor air is suitable for free cooling
 - Free Cooling runs when outdoor air temperature is lower than the set temperature on the economizer control

NOTE: The Free Cooling default setting for outdoor air temperature sensor is 13°C.

High Performance Economizer Features

- Gear-driven action
- High torque 24-volt fully-modulating spring return damper motor
- Return air and outdoor air dampers
- Plug-in connections to unit
- Nylon bearings
- Enhanced thermoplastic vulcanizate (TPV) blade edge seals
- Flexible stainless steel jamb seals to minimize air leakage

High Performance Economizer Control Module

- Module provides inputs and outputs to control economizer based on parameter settings
- Module automatically detects sensors by polling to determine which sensors are installed in system
- Module displays any alarm messages (fault detection and diagnostics) as an aid in troubleshooting
- Non-volatile memory retains parameter settings in case of power failure
- Keypad with four navigation buttons and LCD screen is furnished for setting economizer parameters:
 - Menu Up/Exit (↑) button returns to the main menu
 - Arrow Up (▲) button moves to the previous or next parameter within the selected menu
 - Arrow Down (▼) button moves to the next parameter within the selected menu
 - Select (enter) (↵) button confirms parameter selection



OPTIONS / ACCESSORIES

ECONOMIZER (continued)

Main Menu Structure:

- **Status** (economizer and system operation status)
- **Setpoints** (settings for various setpoint parameters)
- **System Setup** (settings/information about the system)
- **Advanced Setup** (freeze protection, CO₂ settings, stage 3 delay and additional calibration settings)
- **Checkout** (damper positions)
- **Alarms** (output signal that can be configured for remote alarm monitoring)

NOTE - Refer to Installation Instructions for complete setup information and menu parameters available.

Factory or Field Installed

Single Enthalpy Temperature Control

- Outdoor air enthalpy sensor enables Economizer if the outdoor enthalpy is less than the setpoint of the control

Field Installed

Differential Enthalpy Control

- Order two Single Enthalpy Controls
- One is field installed in the return air section, the other in the outdoor air section
- Allows the economizer control board to select between outdoor air or return air, whichever has lower enthalpy

EXHAUST

Field Installed

13 Power Exhaust Fan

- Installs internal to unit for downflow applications only with Economizer option
- Provides exhaust air pressure relief
- Interlocked to run when supply air blower is operating, fan runs when outdoor air dampers are 50% open (adjustable)
- Motor is overload protected
- Fan is 406 mm diameter with 4 fan blades and a 0.25 kW motor

NOTE - If Power Exhaust is field installed with a factory installed Economizer, the Economizer must be ordered with the "No Exhaust" option and the Barometric Relief Dampers with Exhaust Hood must also be ordered separately for field installation.

OUTDOOR AIR

Factory or Field Installed

Outdoor Air Dampers - Downflow or Horizontal

- Single blade damper
- 0 to 25% (fixed) outdoor air adjustable
- Installs in unit
- Automatic model features fully modulating spring return damper motor with plug-in connection
- Manual model features a slide damper
- Maximum mixed air temperature in cooling mode: 38°C

ROOF CURBS

- Nailer strip furnished
- Mates to unit
- US National Roofing Contractors Approved
- Shipped knocked down

Hybrid Roof Curbs, Downflow

- Downflow
- Interlocking tabs fasten corners together
- No tools required
- Can also be fastened together with furnished hardware
- Available in 203, 356, 457, and 610 mm heights.

NOTE - 072 models can be used on smaller 2026 mm Hybrid Roof Curbs (not full perimeter) with 400 mm overhang at condenser end of unit. See dimension drawing on page 24.

Adjustable Pitch Curb

- Downflow
- Fully adjustable pitch curb provides a level platform for rooftop units allowing flexible installations on roofs with uneven or sloped angles
- Maximum slope is 19 mm per 300 mm in any direction
- Uses interlocking tabs to fasten corners together; no tools required
- Hardware is furnished to connect upper curb with lower curb
- Available in 356 mm height

Adaptor Curbs (not shown)

- Curbs are regionally sourced
- Dimensions vary based upon the source

NOTE - Contact your local sales representative for a detailed cut sheet with applicable dimensions.

CEILING DIFFUSERS

Field Installed

Ceiling Diffusers (Flush or Step-Down)

- White powder coat finish on diffuser face and grilles
- Insulated UL listed duct liner
- Diffuser box has collars for duct connection
- Step-down diffusers have double deflection blades
- Flush diffusers have fixed blades
- Provisions for suspending
- Internally sealed to prevent recirculation
- Removable return air grille
- Adapts to T-bar ceiling grids or plaster ceilings

Transitions (Supply and Return)

- Used with diffusers
- Installs in roof curb
- Galvanized steel construction
- Flanges furnished for duct connection to diffusers
- Fully insulated

OPTIONAL CONVENTIONAL TEMPERATURE CONTROL SYSTEMS

ComfortSense® 7500 Commercial 7-Day Programmable Thermostat



- Four-Stage Heating / Two-Stage Cooling
- Universal Multi-Stage
- Intuitive Touchscreen Interface
- Automatic Changeover between Heating and Cooling
- Full Seven-Day Programming
- Four Time Periods Per Day
- Temperature and Humidity Control
- One-Touch Away Mode
- Holiday Scheduling
- Smooth Setback Recovery (SSR)
- Performance Reports
- Notifications/Reminders
- Economizer Relay Control
- Backlit Display
- Wallplate Furnished
- FDD, ASHRAE and IECC Compliant

ComfortSense® 3000 Commercial 5-2 Day Programmable Thermostat



- Two-Stage Heating / Two-Stage Cooling
- Conventional Systems
- Intuitive Interface
- 5-2 Day Programming
- Program Hold
- Remote Indoor Temperature Sensing
- Smooth Setback Recovery (SSR)
- Economizer Relay Control
- Maintenance/Filter/Service Reminders
- Backlit Display
- Wallplate Furnished
- Simple Up and Down Temperature Control

BACnet Compatible Thermostat With Reheat Function



- 7-Day Programmable
- BTL listed MS/TP ensures compatibility with any BACnet system
- Built-in control programs for conventional and heat pump applications
- Conventional systems up to 3-stage heat and 3-stage cool
- Heat pumps with 1 or 2 compressors and up to 2-stage auxiliary heat
- On-board temperature and humidity sensor
- Multiple configurable inputs and outputs enable advanced control strategies
- Set-up Wizard enables rapid system configuration
- No special tools required for installation or commissioning
- Seven-day (2, 4 or 6 event) occupancy scheduling per day
- Backlit 5-inch LCD touchscreen

Description	Catalog No.
ComfortSense® 7500 Commercial 7-Day Programmable Thermostat	
CS7500 7-Day Thermostat	17G74
Sensors/	¹ Remote non-adjustable wall-mount 20k 47W36
Accessories	¹ Remote non-adjustable wall-mount 10k 47W37
	Remote non-adjustable discharge air (duct mount) 19L22
	Outdoor temperature sensor X2658
ComfortSense® 3000 5-2 Day Programmable	
CS3000 5-2 Day Thermostat	11Y05
Sensor/	Remote non-adjustable wall mount 10k averaging 47W37
Accessories	Thermostat wall mounting plate X2659
BACnet Controls	² 7-Day BACnet Thermostat Y8241
	³ BACnet Module (factory or field) 16X70
⁴ BACnet Room Sensors	With Display 97W23
	Without Display 97W24
Universal Thermostat Guard with Lock (clear)	
	Inside Dimensions (H x W) 5 7/8 x 8 3/8 in. 39P21

¹ Remote wall-mount sensors can be applied in any of the following combinations:
 One Sensor - (1) 47W36, Two Sensors - (2) 47W37, Three Sensors - (2) 47W36 and (1) 47W37
 Four Sensors - (4) 47W36, Five Sensors - (3) 47W36 and (2) 47W37

² BACnet Thermostat (Y8241) will control units with and without the Humiditrol® option. If there is a mix of units equipped with and without Humiditrol on the same site, this thermostat can be used for all units if suitable.

³ Not compatible with units equipped with Humiditrol® option.

⁴ Only compatible with BACnet Module (16X70).

OPTIONS / ACCESSORIES

Item	Model No.	Catalog No.	Unit Model Number KHA072
CE MARK			
CE Marked Unit			O
COOLING SYSTEM			
Condensate Drain Trap	Polyvinyl Chloride (PVC) - C1TRAP20AD2	22H54	X
	Copper - C1TRAP10AD2	76W27	X
Drain Pan Overflow Switch	K1SNSR71AB1-	74W42	X
Low Ambient Kit	K1SNSR13A-2	14D96	X
Efficiency		Standard	O
Refrigerant Type		R-410A	O
BLOWER - SUPPLY AIR			
Motor	Belt Drive - 1.5 kW Standard Efficiency		O
Drive Kits	Kit A04 - T1DRKT004-1 - 807 - 1117 rev/min		O
See Blower Data Tables for selection	Kit A08 - T1DRKT008-1 - 994 - 1326 rev/min		O
	Kit A09 - T1DRKT009-1 - 1193 - 1524 rev/min		O
CABINET			
Combination Coil Hail Guards	K1GARD50AP1	13T17	X
Corrosion Protection			O
Hinged Access Panels			O
CONTROLS			
NOTE - Also see Conventional Thermostat Control Systems on page 17 for Additional Options.			
Smoke Detector - Supply or Return (Power board and one sensor)	C1SNSR44AP1	21Z11	X
Smoke Detector - Supply and Return (Power board and two sensors)	C1SNSR43AP1	21Z12	X
ECONOMIZER			
Standard Economizer With Outdoor Air Hood (Sensible Control)			
Standard Economizer - Includes Barometric Relief Dampers and Exhaust Hood	K1ECON30A-3-	14D90	OX
Economizer - No Exhaust		Factory	O
Standard Economizer Controls			
Single Enthalpy Control	C1SNSR64FF1	21Z09	OX
Differential Enthalpy Control (order 2)	C1SNSR64FF1	21Z09	X
High Performance Economizer With Outdoor Air Hood (Sensible Control)			
High Performance Economizer - Includes Barometric Relief Dampers and Exhaust Hood	K1ECON32A-4	20H49	OX
High Performance Economizer - No Exhaust		Factory	O
High Performance Economizer Controls			
Single Enthalpy Control	C1SNSR60FF1	10Z75	OX
Differential Enthalpy Control (order 2)	C1SNSR60FF1	10Z75	X
Economizer Accessories			
Horizontal Economizer Conversion Kit	T1HECK00AN1	17W45	X
OUTDOOR AIR			
Outdoor Air Dampers - Includes Outdoor Air Hood			
Manual	C1DAMP11A-2	15D18	OX
Motorized	C1DAMP21A-1	15D17	OX
POWER EXHAUST FAN			
Standard Static <i>NOTE - Order Barometric Relief Dampers with Exhaust Hood below if unit is ordered with factory installed Economizer with "No Exhaust" option</i>	380/420V-3ph - C1PWRE10A-1M	21Z16	X
¹ BAROMETRIC RELIEF			
Barometric Relief Dampers with Exhaust Hood	C1DAMP50A-1-	74W38	X

¹ Required when Economizer is factory installed (no exhaust option) with field installed Power Exhaust Fan option.

NOTE - The catalog and model numbers that appear here are for ordering field installed accessories only.

OX - Field Installed or Configure to Order (Factory installed)

O - Configure to Order (Factory Installed)

X - Field Installed.

OPTIONS / ACCESSORIES

Item	Model No.	Catalog No.	Unit Model Number KHA072
ELECTRICAL			
Voltage 50 hz with neutral (No neutral on CE marked models)	380/420V - 3 phase		O
¹ ELECTRIC HEAT			
5.7 kW	K1EH0057AN1M	67W92	X
11.5 kW	K1EH0115AN1M	67W93	X
17.2 kW	K1EH0172AN1M	67W94	X
23 kW	K1EH0230N-1M	67W95	X
INDOOR AIR QUALITY			
Air Filters			
Healthy Climate® High Efficiency Air Filters	MERV 8 (406 x 508 x 51) - C1FLTR15A-1-	54W20	
	MERV 13 (406 x 508 x 51) - T1FLTR40A-1-	52W37	
Order 4 per unit	MERV 8 (508 x 508 x 51) - C1FLTR15D-1-	54W21	X
	MERV 13 (508 x 508 x 51) - C1FLTR40D-1-	52W39	X
Indoor Air Quality (CO₂) Sensors			
Sensor - Wall-mount, off-white plastic cover with LCD display	C0SNSR50AE1L	77N39	X
Sensor - Wall-mount, black plastic case, no display, rated for plenum mounting	C0SNSR53AE1L	87N54	X
CO ₂ Sensor Duct Mounting Kit - for downflow applications	C0MISC19AE1-	85L43	X
Aspiration Box - for duct mounting non-plenum rated CO ₂ sensor (77N39)	C0MISC16AE1-	90N43	X
UVC Germicidal Lamps			
² Healthy Climate® UVC Light Kit (220V-1ph)	E1UVCL10AN1-	21A92	X
ROOF CURBS			
Hybrid Roof Curbs, Downflow			
203 mm height	C1CURB70A-1	11F50	² X
356 mm height	C1CURB71A-1	11F51	² X
457 mm height	C1CURB72A-1	11F52	² X
610 mm height	C1CURB73A-1	11F53	² X
Hybrid Roof Curbs, Full Perimeter, Downflow			
203 mm height	K1CURB70AP1	11S47	X
356 mm height	K1CURB71AP1	11S48	X
457 mm height	K1CURB72AP1	11T01	X
610 mm height	K1CURB73AP1	11T06	X
Adjustable Pitch Curb, Downflow			
356 mm height	C1CURB55AT1	43W27	³ X
CEILING DIFFUSERS			
Step-Down - Order one	RTD11-95S	13K61	X
Flush - Order one	FD11-95S	13K56	X
Transitions (Supply and Return) - Order one	T1TRAN20N-1	17W54	X

¹ Nominal kW at 420V-3ph-50hz.

² Lamps operate on 110-230V single-phase power supply. Step-down transformer may be ordered separately for 460V and 575V units. Alternately, 110V power supply may be used to directly power the UVC ballast(s).

³ KHA072 model will fit smaller roof curbs with overhang. See dimension drawing.

NOTE - The catalog and model numbers that appear here are for ordering field installed accessories only.

OX - Field Installed or Configure to Order (Factory installed)

O - Configure to Order (Factory Installed)

X - Field Installed.

SPECIFICATIONS

General Data		Nominal Size	21 kW (6 Ton)
		Model No.	KHA072S4B
		Efficiency Type	Standard
		Blower Type	Single Speed Belt Drive
Cooling Performance	Gross Cooling Capacity - kW (Btuh)	18.1 (61 800)	
	¹ Net Cooling Capacity - kW (Btuh)	17.4 (59 300)	
	AHRI Rated Air Flow - L/s (cfm)	970 (2060)	
	² Sound Rating Number (dB)	83	
	Total Unit Power - kW	5.6	
	¹ EER (Btuh/Watt)	11.0	
	¹ IEER (Btuh/Watt)	12.1	
Refrigerant	Type	R-410A	
	Charge Furnished	9.30 kg (20 lbs. 8 oz.)	
Heating Performance	Total High Heating Capacity - kW (Btuh)	18.4 (63 000)	
	Total Unit Power - kW	5.8	
	¹ COP	3.3	
	Total Low Heating Capacity - kW (Btuh)	10.5 (36 000)	
	Total Unit Power - kW	4.7	
	¹ COP	2.25	
Electric Heating Options		See Electric Heat, page 16	
Compressor Type (no.)		Scroll (1)	
Outdoor Coil	Net face area - m ² (sq. ft.)	2.6 (28.00)	
	Tube diameter - mm (in.)	9.5 (3/8)	
	Number of rows	2	
	Fins per meter (Fins / inch)	788 (20)	
Outdoor Coil Fan	Motor W (HP)	374 (1/2)	
	Motor rev/min	900	
	Total motor watts	520	
	Diameter - mm (in.) / No. of blades	610 (24) - 4	
	Total air volume - L/s (cfm)	2260 (4780)	
Indoor Coil	Net face area - m ² (sq. ft.)	0.90 (9.7)	
	Tube diameter - mm (in.)	9.5 (3/8)	
	Number of rows	4	
	Fins per meter (Fins / inch)	552 (14)	
	Drain Connection (no. and size) - in.	(1) 1 NPT	
	Expansion device type	Balanced Port Thermostatic Expansion Valve, removeable power head	
³ Indoor Blower & Drive Selection	Nominal Motor kW (HP)	1.5 (2)	
	Maximum Usable Motor kW (HP)	1.7 (2.3)	
	Wheel nom. diameter x width - mm (in.)	254 x 254 (10 x 10)	
	Drive Kit (rev/min range)	A04 - (807 - 1117) A08 - (994-1326) A09 - (1193 - 1524)	
Filters	Type	Disposable	
	Number and size - mm (in.)	(4) 20 x 20 x 2	
Electrical Characteristics - 50 hz		380/420V - 50 hertz - 3 phase with neutral (No neutral on CE marked models)	

NOTE - Net capacity includes evaporator blower motor heat deduction. Gross capacity does not include evaporator blower motor heat deduction.

¹ Rating test conditions are those included in Air-Conditioning, Heating and Refrigeration Institute (AHRI) Standard 1340/360 while operating at rated voltage and air volumes:

Cooling Ratings - 35°C (95°F) outdoor air temperature and 27°C (80°F) dry bulb/19°C (67°F) wet bulb entering indoor coil air.

High Temperature Heating Ratings - 8°C (47°F) dry bulb/6°C (43°F) wet bulb outdoor air temperature and 21°C (70°F) entering indoor coil air.

Low Temperature Heating Ratings - -8°C (17°F) dry bulb/-9°C (15°F) wet bulb outdoor air temperature and 21°C (70°F) entering indoor coil air.

² Sound Rating Number rated in accordance with test conditions included in AHRI Standard 270.

³ Using total air volume and system static pressure requirements determine from blower performance tables rev/min and motor size required. Maximum usable size of motors furnished is shown. If motors of comparable size are used, be sure to keep within the service factor limitations outlined on the motor nameplate.

COOLING / HEATING RATINGS

NOTE - For Temperatures and Capacities not shown in tables, see bulletin - Cooling Unit Rating Table Correction Factor Data in Miscellaneous Engineering Data section.

21 KW - KHA072S4 - COOLING CAPACITY

Entering Wet Bulb Temperature	Total Air Volume	Outdoor Air Temperature Entering Outdoor Coil																				
		26.7°C						35°C					43.3°C					46°C				
		Total Cool Cap.	Comp. Motor Input	Sensible To Total Ratio (S/T)			Total Cool Cap.	Comp. Motor Input	Sensible To Total Ratio (S/T)			Total Cool Cap.	Comp. Motor Input	Sensible To Total Ratio (S/T)			Total Cool Cap.	Comp. Motor Input	Sensible To Total Ratio (S/T)			
				Dry Bulb					Dry Bulb					Dry Bulb					Dry Bulb			
		L/s	kW	kW	24°C	27°C	29°C	kW	kW	24°C	27°C	29°C	kW	kW	24°C	27°C	29°C	kW	kW	24°C	27°C	29°C
17.2°C	905	18.5	3.55	0.72	0.9	1	16.7	4.16	0.74	0.95	1	14.7	4.88	0.77	1	1	14.1	5.14	0.82	1	1	
	1135	19.5	3.56	0.78	1	1	17.8	4.16	0.81	1	1	15.9	4.88	0.87	1	1	15.3	5.15	0.92	1	1	
	1360	20.6	3.56	0.86	1	1	18.9	4.17	0.9	1	1	16.9	4.89	0.97	1	1	16.2	5.14	0.99	1	1	
19.4°C	905	19.8	3.56	0.55	0.7	0.85	17.9	4.16	0.56	0.72	0.9	15.8	4.89	0.57	0.75	0.97	15.0	5.15	0.59	0.80	0.99	
	1135	20.7	3.56	0.6	0.76	0.96	18.7	4.16	0.6	0.78	1	16.5	4.89	0.62	0.84	1	15.8	5.14	0.65	0.89	1	
	1360	21.4	3.57	0.63	0.83	1	19.4	4.16	0.64	0.88	1	17.1	4.89	0.67	0.94	1	16.4	5.14	0.71	0.97	1	
21.7°C	905	21.1	3.56	0.41	0.54	0.68	19.1	4.16	0.4	0.55	0.7	17	4.89	0.38	0.56	0.72	16.2	5.14	0.39	0.59	0.77	
	1135	22.1	3.57	0.43	0.59	0.74	20	4.17	0.42	0.6	0.77	17.7	4.89	0.41	0.61	0.81	17.0	5.14	0.42	0.64	0.87	
	1360	22.8	3.57	0.45	0.63	0.81	20.7	4.17	0.44	0.64	0.85	18.3	4.89	0.44	0.67	0.91	17.5	5.15	0.45	0.71	0.95	

Entering Wet Bulb Temperature	Total Air Volume	Outdoor Air Temperature Entering Outdoor Coil														
		48°C					50°C					51.7°C				
		Total Cool Cap.	Comp. Motor Input	Sensible To Total Ratio (S/T)			Total Cool Cap.	Comp. Motor Input	Sensible To Total Ratio (S/T)			Total Cool Cap.	Comp. Motor Input	Sensible To Total Ratio (S/T)		
				Dry Bulb					Dry Bulb					Dry Bulb		
		L/s	kW	kW	24°C	27°C	29°C	kW	kW	24°C	27°C	29°C	kW	kW	24°C	27°C
17.2°C	905	13.6	5.35	0.84	1	1	13.1	5.57	0.85	1	1	12.7	5.76	0.83	1	1
	1135	14.8	5.35	0.93	1	1	14.2	5.57	0.95	1	1	13.8	5.76	0.96	1	1
	1360	15.7	5.35	1	1	1	15.2	5.57	1	1	1	14.7	5.76	1	1	1
19.4°C	905	14.4	5.35	0.59	0.81	1	13.8	5.56	0.60	0.82	1	13.4	5.76	0.58	0.8	1
	1135	15.2	5.35	0.66	0.91	1	14.6	5.56	0.67	0.92	1	14.1	5.76	0.65	0.92	1
	1360	15.7	5.35	0.72	0.99	1	15.2	5.57	0.73	1	1	14.7	5.76	0.7	1	1
21.7°C	905	15.6	5.35	0.39	0.59	0.78	15.0	5.56	0.38	0.59	0.80	14.5	5.76	0.37	0.57	0.77
	1135	16.4	5.35	0.42	0.65	0.88	15.7	5.57	0.42	0.66	0.90	15.2	5.76	0.41	0.64	0.89
	1360	16.8	5.35	0.45	0.72	0.97	16.2	5.57	0.45	0.73	0.98	15.6	5.76	0.44	0.7	0.99

21 KW - KHA072S4 - HEATING CAPACITY

Indoor Coil Air Volume 21°C Dry Bulb	Air Temperature Entering Outdoor Coil									
	18°C		7°C		-4°C		-15°C		-28°C	
	Total Heating Capacity	Comp. Motor Input	Total Heating Capacity	Comp. Motor Input	Total Heating Capacity	Comp. Motor Input	Total Heating Capacity	Comp. Motor Input	Total Heating Capacity	Comp. Motor Input
	L/s	kW	kW	kW	kW	kW	kW	kW	kW	kW
906	22.9	4.65	17.4	4.14	11.9	3.59	7.3	3.22	3.5	2.43
1133	23.5	4.42	18.1	3.91	12.5	3.37	7.9	3.00	4.1	2.21
1359	24.0	4.28	18.5	3.78	13.0	3.23	8.4	2.86	4.6	2.07

BLOWER DATA - BELT DRIVE - KHA072 - DOWNFLOW

BLOWER TABLE INCLUDES RESISTANCE FOR BASE UNIT ONLY WITH DRY INDOOR COIL AND AIR FILTERS IN PLACE.

FOR ALL UNITS ADD:

1 - Any factory installed options air resistance (heat section, economizer, etc.).

2 - Any field installed accessories air resistance (duct resistance, diffuser, etc.).

See page 15 for blower motors and drives and wet coil and options/accessory air resistance data.

Air Volume		External Static - Pa (in. w.g.)																		
		25 (0.10)		50 (0.20)		75 (0.30)		100 (0.40)		125 (0.50)		150 (0.60)		175 (0.70)		200 (0.80)				
L/s	cfm	Rev/min	BHP	Rev/min	BHP	Rev/min	BHP	Rev/min	BHP	Rev/min	BHP	Rev/min	BHP	Rev/min	BHP	Rev/min	BHP			
897	1900	826	0.27	0.36	0.41	0.45	0.45	928	0.37	0.50	0.56	1000	0.46	0.61	1036	0.49	0.66	1072	0.52	0.70
944	2000	857	0.31	0.42	0.47	0.52	0.52	952	0.43	0.57	0.62	1020	0.51	0.68	1055	0.54	0.73	1091	0.57	0.77
991	2100	878	0.37	0.49	0.54	0.59	0.59	973	0.48	0.64	0.70	1041	0.56	0.75	1076	0.60	0.80	1112	0.63	0.85
1038	2200	897	0.41	0.55	0.61	0.66	0.66	994	0.54	0.72	0.78	1063	0.62	0.83	1099	0.66	0.89	1134	0.69	0.93
1085	2300	918	0.46	0.62	0.68	0.74	0.74	1017	0.60	0.80	0.86	1087	0.69	0.92	1122	0.72	0.97	1157	0.76	1.02
1133	2400	941	0.52	0.70	0.77	0.83	0.83	1042	0.67	0.90	0.96	1111	0.75	1.01	1146	0.79	1.06	1181	0.83	1.11
1180	2500	966	0.59	0.79	0.86	0.93	0.93	1068	0.75	1.00	1.06	1137	0.83	1.11	1171	0.87	1.16	1205	0.90	1.20
1227	2600	994	0.67	0.90	0.97	1.04	1.04	1096	0.82	1.10	1.16	1164	0.90	1.21	1197	0.94	1.26	1231	0.97	1.30
1274	2700	1023	0.75	1.01	1.08	1.15	1.15	1125	0.91	1.22	1.27	1192	0.98	1.32	1225	1.02	1.37	1258	1.05	1.41
1321	2800	1053	0.84	1.13	1.21	1.27	1.27	1155	0.99	1.33	1.39	1221	1.07	1.43	1253	1.10	1.48	1286	1.14	1.53
1369	2900	1085	0.94	1.26	1.33	1.40	1.40	1186	1.08	1.45	1.51	1250	1.16	1.55	1281	1.20	1.61	1313	1.24	1.66
Air Volume		External Static - Pa (in. w.g.)																		
		225 (0.90)		250 (1.00)		275 (1.10)		300 (1.20)		325 (1.30)		350 (1.40)		375 (1.50)		400 (1.60)				
L/s	cfm	Rev/min	BHP	Rev/min	BHP	Rev/min	BHP	Rev/min	BHP	Rev/min	BHP	Rev/min	BHP	Rev/min	BHP	Rev/min	BHP			
897	1900	1109	0.56	0.75	0.79	0.82	0.82	1221	0.64	0.86	0.90	1294	0.70	0.94	1323	0.73	0.98	1349	0.76	1.02
944	2000	1128	0.61	0.82	0.86	0.89	0.89	1239	0.69	0.93	0.97	1310	0.75	1.01	1336	0.79	1.06	1362	0.82	1.10
991	2100	1148	0.66	0.89	0.93	0.97	0.97	1258	0.75	1.01	1.05	1325	0.81	1.09	1351	0.85	1.14	1376	0.89	1.19
1038	2200	1170	0.72	0.97	1.01	1.05	1.05	1277	0.81	1.09	1.14	1341	0.88	1.18	1365	0.92	1.23	1390	0.95	1.28
1085	2300	1193	0.79	1.06	1.09	1.14	1.14	1295	0.89	1.19	1.24	1355	0.96	1.29	1380	0.99	1.33	1406	1.02	1.37
1133	2400	1216	0.86	1.15	1.19	1.24	1.24	1313	0.97	1.30	1.36	1371	1.04	1.40	1396	1.07	1.44	1423	1.10	1.48
1180	2500	1240	0.93	1.24	1.29	1.36	1.36	1331	1.06	1.42	1.48	1388	1.13	1.52	1414	1.16	1.55	1441	1.18	1.58
1227	2600	1265	1.00	1.34	1.40	1.47	1.47	1352	1.15	1.54	1.60	1408	1.22	1.64	1434	1.25	1.67	1460	1.27	1.70
1274	2700	1291	1.09	1.46	1.52	1.59	1.59	1374	1.25	1.67	1.72	1429	1.31	1.76	1455	1.34	1.79	1481	1.36	1.82
1321	2800	1317	1.18	1.58	1.66	1.74	1.74	1399	1.34	1.80	1.85	1451	1.41	1.89	1477	1.43	1.92	1503	1.45	1.95
1369	2900	1343	1.28	1.72	1.80	1.88	1.88	1424	1.45	1.95	1.99	1475	1.51	2.02	1500	1.53	2.05	1526	1.55	2.08

BLOWER DATA - BELT DRIVE - KHA072 - HORIZONTAL

BLOWER TABLE INCLUDES RESISTANCE FOR BASE UNIT ONLY WITH DRY INDOOR COIL AND AIR FILTERS IN PLACE.

FOR ALL UNITS ADD:

1 - Any factory installed options air resistance (heat section, economizer, etc.);

2 - Any field installed accessories air resistance (duct resistance, diffuser, etc.);

See page 15 for blower motors and drives and wet coil and options/accessory air resistance data.

Air Volume		External Static - Pa (in. w.g.)																
		25 (0.10)		50 (0.20)		75 (0.30)		100 (0.40)		125 (0.50)		150 (0.60)		175 (0.70)		200 (0.80)		
L/s	cfm	Rev/ min	BHP	Rev/ min	BHP	Rev/ min	BHP	Rev/ min	BHP	Rev/ min	BHP	Rev/ min	BHP	Rev/ min	BHP	Rev/ min	BHP	
897	1900	853	0.31	0.41	886	0.34	0.46	0.50	0.55	986	0.45	0.60	0.64	1021	0.48	0.51	0.69	0.73
944	2000	883	0.36	0.48	913	0.40	0.53	0.57	0.62	1009	0.50	0.67	0.71	1043	0.53	0.57	0.76	0.80
991	2100	906	0.42	0.56	936	0.45	0.60	0.65	0.70	1033	0.56	0.75	0.79	1067	0.59	0.63	0.84	0.88
1038	2200	930	0.48	0.64	960	0.51	0.68	0.73	0.78	1058	0.62	0.83	0.88	1092	0.66	0.69	0.92	0.96
1085	2300	954	0.54	0.72	985	0.57	0.77	0.82	0.87	1085	0.69	0.92	0.96	1119	0.72	0.75	1.00	1.04
1133	2400	981	0.60	0.81	1013	0.64	0.86	0.91	0.96	1113	0.75	1.00	1.05	1146	0.78	0.81	1.09	1.13
1180	2500	1010	0.68	0.91	1042	0.72	0.96	1.00	1.05	1142	0.81	1.09	1.14	1175	0.85	0.88	1.18	1.23
1227	2600	1040	0.75	1.01	1073	0.78	1.05	1.10	1.14	1171	0.89	1.19	1.23	1203	0.92	0.95	1.28	1.33
1274	2700	1072	0.82	1.10	1104	0.86	1.15	1.20	1.24	1201	0.96	1.29	1.34	1232	1.00	1.04	1.40	1.46
1321	2800	1105	0.90	1.21	1137	0.93	1.25	1.30	1.35	1231	1.04	1.40	1.46	1261	1.09	1.13	1.52	1.59
1369	2900	1138	0.98	1.32	1169	1.02	1.37	1.42	1.47	1261	1.14	1.53	1.60	1291	1.19	1.24	1.66	1.73

Air Volume		External Static - Pa (in. w.g.)																
		225 (0.90)		250 (1.00)		275 (1.10)		300 (1.20)		325 (1.30)		350 (1.40)		375 (1.50)		400 (1.60)		
L/s	cfm	Rev/ min	BHP	Rev/ min	BHP	Rev/ min	BHP	Rev/ min	BHP	Rev/ min	BHP	Rev/ min	BHP	Rev/ min	BHP	Rev/ min	BHP	
897	1900	1126	0.57	0.77	1163	0.60	0.81	1.00	0.85	1237	0.66	0.88	1.08	1.04	1306	0.72	0.96	1.04
944	2000	1148	0.63	0.84	1183	0.66	0.88	1.08	0.92	1257	0.72	0.96	1.16	1.04	1323	0.78	1.04	1.12
991	2100	1170	0.69	0.92	1206	0.72	0.96	1.16	1.00	1277	0.78	1.04	1.24	1.13	1340	0.84	1.13	1.21
1038	2200	1195	0.75	1.00	1230	0.78	1.04	1.24	1.08	1299	0.84	1.13	1.33	1.23	1359	0.92	1.23	1.31
1085	2300	1220	0.81	1.08	1254	0.84	1.13	1.33	1.17	1320	0.92	1.23	1.43	1.34	1378	1.00	1.34	1.42
1133	2400	1245	0.88	1.18	1278	0.91	1.22	1.42	1.28	1341	0.99	1.33	1.52	1.45	1397	1.08	1.45	1.54
1180	2500	1271	0.95	1.28	1303	0.99	1.33	1.53	1.39	1363	1.08	1.45	1.62	1.57	1418	1.17	1.57	1.66
1227	2600	1297	1.04	1.39	1328	1.08	1.45	1.63	1.52	1385	1.18	1.58	1.71	1.64	1439	1.27	1.70	1.78
1274	2700	1323	1.13	1.52	1353	1.18	1.58	1.73	1.65	1409	1.28	1.72	1.81	1.77	1462	1.36	1.82	1.90
1321	2800	1351	1.23	1.65	1380	1.28	1.72	1.81	1.78	1434	1.38	1.85	1.94	1.90	1486	1.45	1.95	2.02
1369	2900	1379	1.34	1.79	1407	1.39	1.86	1.95	1.92	1460	1.48	1.98	2.07	2.04	1511	1.55	2.08	2.15

BLOWER DATA

BELT DRIVE KIT SPECIFICATIONS

Model No.	Motor kW (HP)		No. of Speeds	Drive Kits and Rev/Min Range		
	Nominal	Max		A04	A08	A09
072	1.5 (2)	1.7 (2.3)	1	807 - 1117	994 - 1326	1193 - 1524

NOTE - Using total air volume and system static pressure requirements determine from blower performance tables rev/min and motor kW required. Maximum usable kW of motors furnished are shown. If motors of comparable kW are used, be sure to keep within the service factor limitations outlined on the motor nameplate.

OPTIONS / ACCESSORIES AIR RESISTANCE

Air Volume		Wet Indoor Coil		Economizer		Electric Heat		Filters			
								MERV 8		MERV 13	
L/s	cfm	Pa	in. w.g.	Pa	in. w.g.	Pa	in. w.g.	Pa	in. w.g.	Pa	in. w.g.
850	1800	7	0.04	12	0.05	37	0.15	12	0.05	17	0.07
945	2000	12	0.05	12	0.05	45	0.18	12	0.05	20	0.08
1040	2200	15	0.06	12	0.05	50	0.20	12	0.05	20	0.08
1130	2400	17	0.07	12	0.05	55	0.22	12	0.05	20	0.08
1225	2600	20	0.08	15	0.06	60	0.24	12	0.05	20	0.08
1320	2800	22	0.09	15	0.06	65	0.26	12	0.05	20	0.08
1415	3000	25	0.10	15	0.06	70	0.28	12	0.05	20	0.08

POWER EXHAUST FAN PERFORMANCE

Return Air System Static Pressure		Air Volume Exhausted	
Pa	in. w.g.	L/s	cfm
0	0.00	944	2000
12	0.05	939	1990
25	0.10	908	1924
37	0.15	854	1810
50	0.20	785	1664
62	0.25	711	1507
75	0.30	637	1350
87	0.35	571	1210

CEILING DIFFUSERS AIR RESISTANCE

Air Volume		RTD11-95S Step-Down Diffuser						FD11-95S Flush Diffuser	
		2 Ends Open		1 Side & 2 Ends Open		All Ends & Sides Open			
L/s	cfm	Pa	in. w.g.	Pa	in. w.g.	Pa	in. w.g.	Pa	in. w.g.
850	1800	32	0.13	27	0.11	22	0.09	22	0.09
945	2000	37	0.15	32	0.13	27	0.11	25	0.10
1040	2200	45	0.18	37	0.15	30	0.12	30	0.12
1130	2400	52	0.21	45	0.18	37	0.15	35	0.14
1225	2600	60	0.24	52	0.21	45	0.18	42	0.17
1320	2800	67	0.27	60	0.24	52	0.21	50	0.20
1415	3000	80	0.32	72	0.29	62	0.25	62	0.25

CEILING DIFFUSER AIR THROW DATA

Air Volume		¹ Effective Throw			
Model No.		RTD11-95S		FD11-95S	
1225	2600	7 - 9	24 - 29	6 - 7	19 - 24
1320	2800	8 - 9	25 - 30	6 - 9	20 - 28
1415	3000	8 - 10	27 - 33	6 - 9	21 - 29

¹ Effective throw based on terminal velocities of 23 m per minute (75 ft. per minute).

ELECTRICAL / ELECTRIC HEAT DATA

Model No.	KHA072S4		
¹ Voltage - 50hz with Neutral	380/420V - 3 Ph		
Compressor	Rated Load Amps	9.7	
	Locked Rotor Amps	64	
Outdoor Fan Motor	Full Load Amps	1.5	
Power Exhaust (1) 0.25 kW	Full Load Amps	1.3	
Indoor Blower Motor	kW	1.5	
	Full Load Amps	3.6	
² Maximum Overcurrent Protection	Unit Only	25	
	With (1) 0.25 kW Power Exhaust	25	
³ Minimum Circuit Ampacity	Unit Only	18	
	With (1) 0.25 kW Power Exhaust	19	

ELECTRIC HEAT DATA

Electric Heat Voltage				420V
² Maximum Overcurrent Protection	Unit+	5.7 kW	30	
	⁴ Electric Heat	11.5 kW	40	
		17.2 kW	50	
		23 kW	60	
³ Minimum Circuit Ampacity	Unit+	5.7 kW	28	
	⁴ Electric Heat	11.5 kW	37	
		17.2 kW	47	
		23 kW	57	
² Maximum Overcurrent Protection	Unit+	5.7 kW	35	
	⁴ Electric Heat and (1) 0.25 kW Power Exhaust	11.5 kW	40	
		17.2 kW	50	
		23 kW	60	
³ Minimum Circuit Ampacity	Unit+	5.7 kW	29	
	⁴ Electric Heat and (1) 0.25 kW Power Exhaust	11.5 kW	39	
		17.2 kW	49	
		23 kW	58	

¹ Extremes of operating range are plus and minus 10% of line voltage.

² Heating, Air Conditioning, Refrigeration type breaker or fuse.

³ Refer to local electrical code to determine wire, fuse and disconnect size requirements.

⁴ Nominal kW based on 420V-3ph-50hz.

ELECTRIC HEAT CAPACITIES

Input Voltage	5.7 kW			11.5 kW			17.2 kW			23 kW		
	No of Steps	kW input	Btuh Output	No of Steps	kW input	Btuh Output	No of Steps	kW input	Btuh Output	No of Steps	kW input	Btuh Output
380	1	4.7	16 100	1	9.4	32 100	1	14.1	48 200	1	18.8	64 200
400	1	5.2	17 800	1	10.4	35 500	1	15.6	53 300	1	20.9	71 400
420	1	5.7	19 500	1	11.5	39 300	1	17.2	58 800	1	23.0	78 500

UNIT CLEARANCES

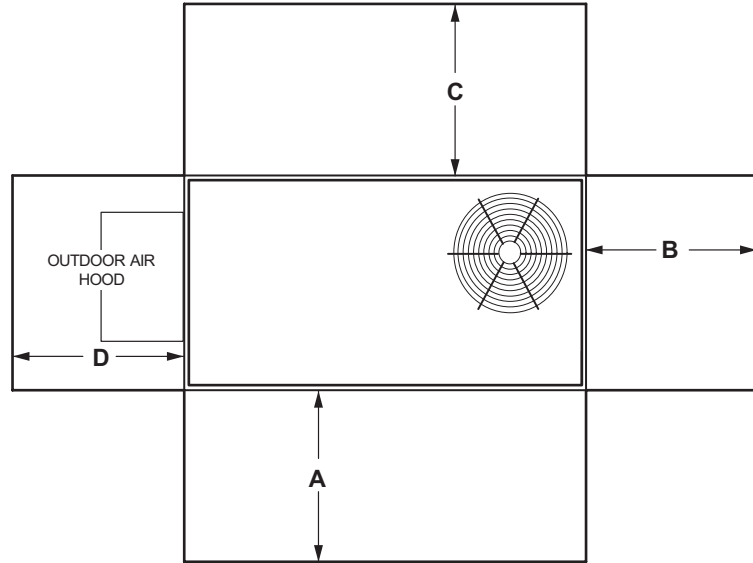

¹ Unit Clearance	A		B		C		D		Top Clearance
	mm	in.	mm	in.	mm	in.	mm	in.	
Service Clearance	914	36	914	36	914	36	914	36	Unobstructed
Minimum Operation Clearance	914	36	914	36	914	36	914	36	

NOTE - Entire perimeter of unit base requires support when elevated above the mounting surface.

¹ Service Clearance - Required for removal of serviceable parts.

Minimum Operation Clearance - Required clearance for proper unit operation.

OUTDOOR SOUND DATA

¹ Unit Model No.	Octave Band Linear Sound Power Levels dBA, re 10 ⁻¹² Watts - Center Frequency - Hz							¹ Sound Rating Number (SRN) (dBA)
	125	250	500	1000	2000	4000	8000	
KHA072	67	75	78	78	75	68	59	83

Note - The octave sound power data does not include tonal corrections.

¹ Sound Rating Number according to ARI Standard 270-95 (includes pure tone penalty). "SRN" is the overall A-Weighted Sound Power Level, (LWA), dBA (100 Hz to 10,000 Hz).

WEIGHT DATA

Model Number	Net				Shipping			
	Base		Max.		Base		Max.	
	kg	lbs.	kg	lbs.	kg	lbs.	kg	lbs.
KHA072S	340	750	391	862	367	810	422	931

Base Unit - The unit with NO OPTIONS.

Max. Unit - The unit with ALL OPTIONS Installed (Economizer, etc.)

OPTIONS / ACCESSORIES

	Shipping Weights		
	kg	lbs.	
ECONOMIZER			
Economizer			
Economizer, Includes Outdoor Air Hood and Barometric Relief Dampers with Hood	59	131	
outdoor air			
Outdoor Air Dampers			
Motorized	18	40	
Manual	14	30	
Power Exhaust			
Standard Static	16	35	
ELECTRIC HEAT			
5.7 kW	14	31	
11.5 kW	14	31	
17.2 kW	16	35	
23 kW	16	35	
ROOF CURBS			
Hybrid Roof Curbs, Downflow			
203 mm height	23	50	
356 mm height	32	70	
457 mm height	36	80	
610 mm height	45	100	
Hybrid Curbs, Full Perimeter, Downflow			
203 mm height	26	57	
356 mm height	27	60	
457 mm height	41	91	
610 mm height	52	114	
Adjustable Pitch Curb, Downflow			
356 mm height	51	113	
CEILING DIFFUSERS			
Step-Down	RTD11-95S	54	118
Flush	FD11-95S	54	118
Transitions (Supply and Return)	T1TRAN20N-1	10	21

DIMENSIONS - UNIT

Model No.	CORNER WEIGHTS								CENTER OF GRAVITY															
	AA		BB		CC		DD		EE		FF													
	Base	Max.	Base	Max.	Base	Max.	Base	Max.	Base	Max.	Base	Max.												
	kg	lbs.	kg	lbs.	kg	lbs.	kg	lbs.	mm	in.	mm	in.												
072	73	160	84	185	82	180	94	208	106	233	122	269	94	207	109	239	1174	46-1/4	1174	46-1/4	521	20-1/2	521	20-1/2

Base Unit - The unit with standard heat exchanger NO OPTIONS.
 Max. Unit - The unit with ALL OPTIONS Installed (Economizer, etc.).

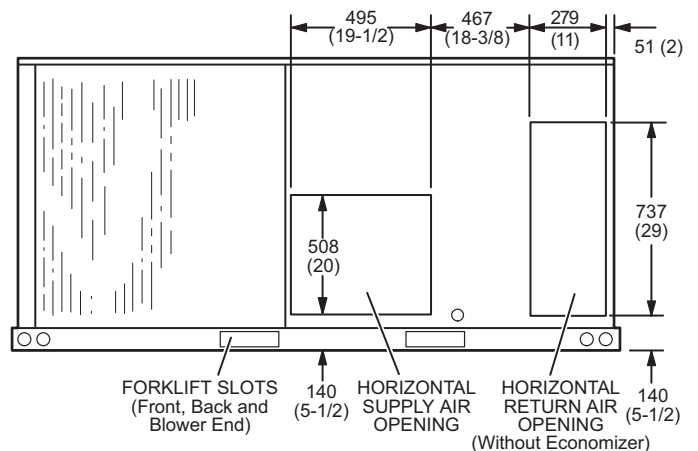
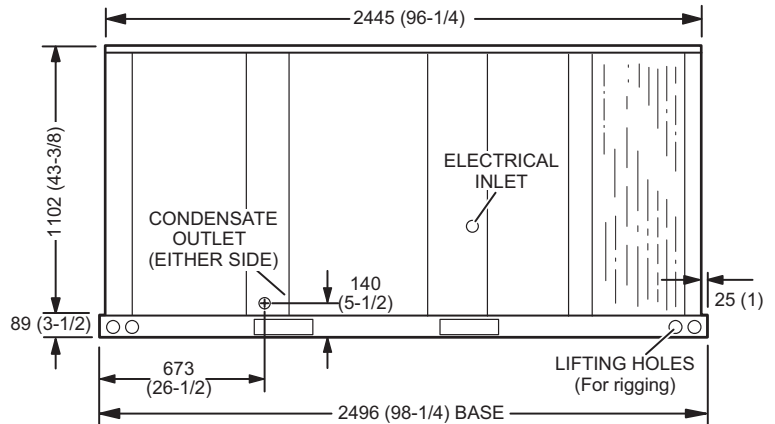
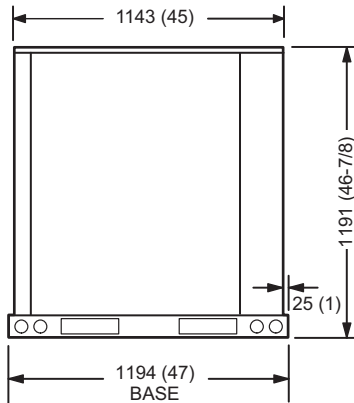
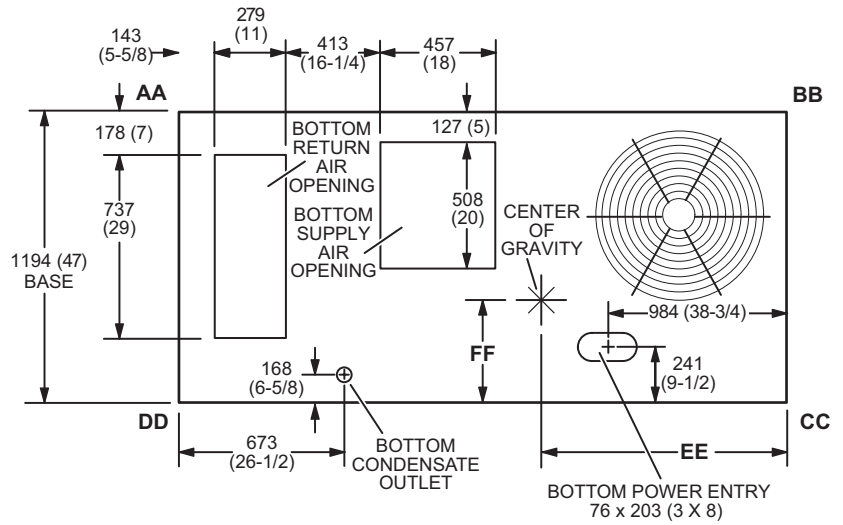

DIMENSIONS - ACCESSORIES

COMBINATION OUTDOOR AIR HOOD DETAIL FOR OPTIONAL ECONOMIZER AND BAROMETRIC RELIEF DAMPERS (Furnished With Economizer for Downflow Applications)

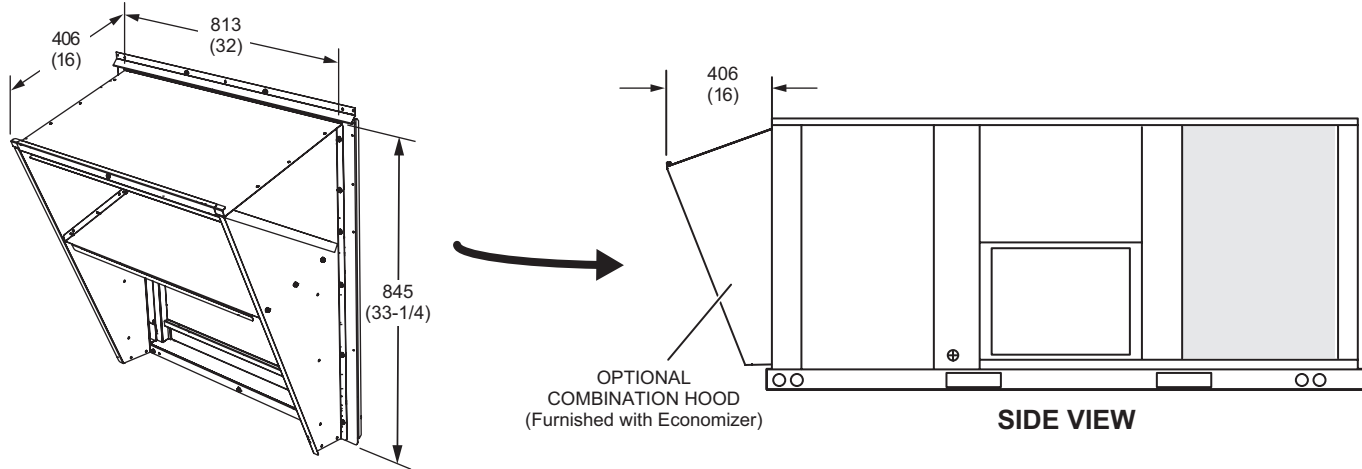

OUTDOOR AIR DAMPER HOOD DETAIL (Downflow or Horizontal Applications)

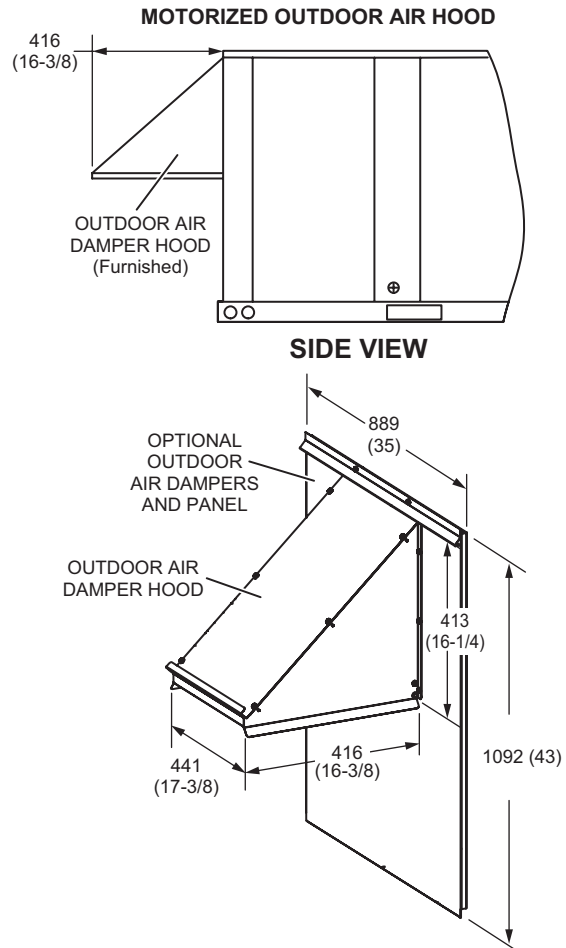
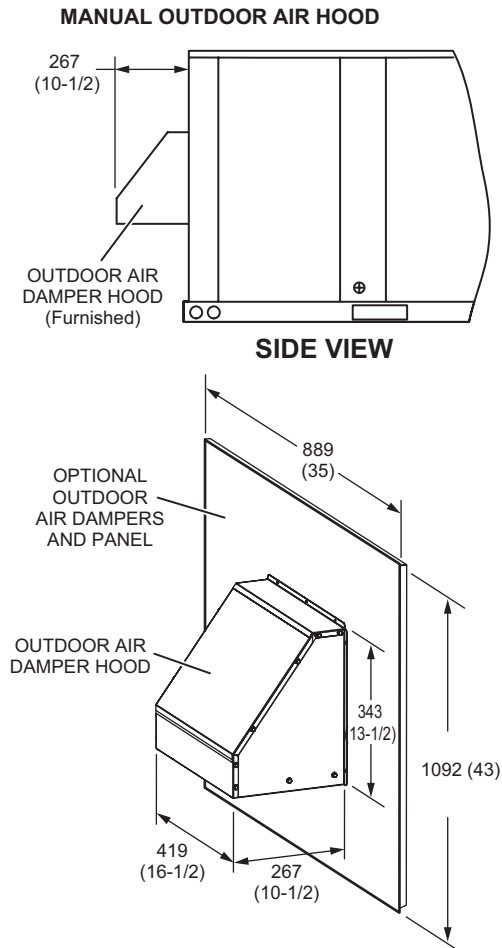

DIMENSIONS - ACCESSORIES

OUTDOOR AIR HOOD DETAIL WITH OPTIONAL ECONOMIZER AND BAROMETRIC RELIEF DAMPERS (Horizontal Applications)

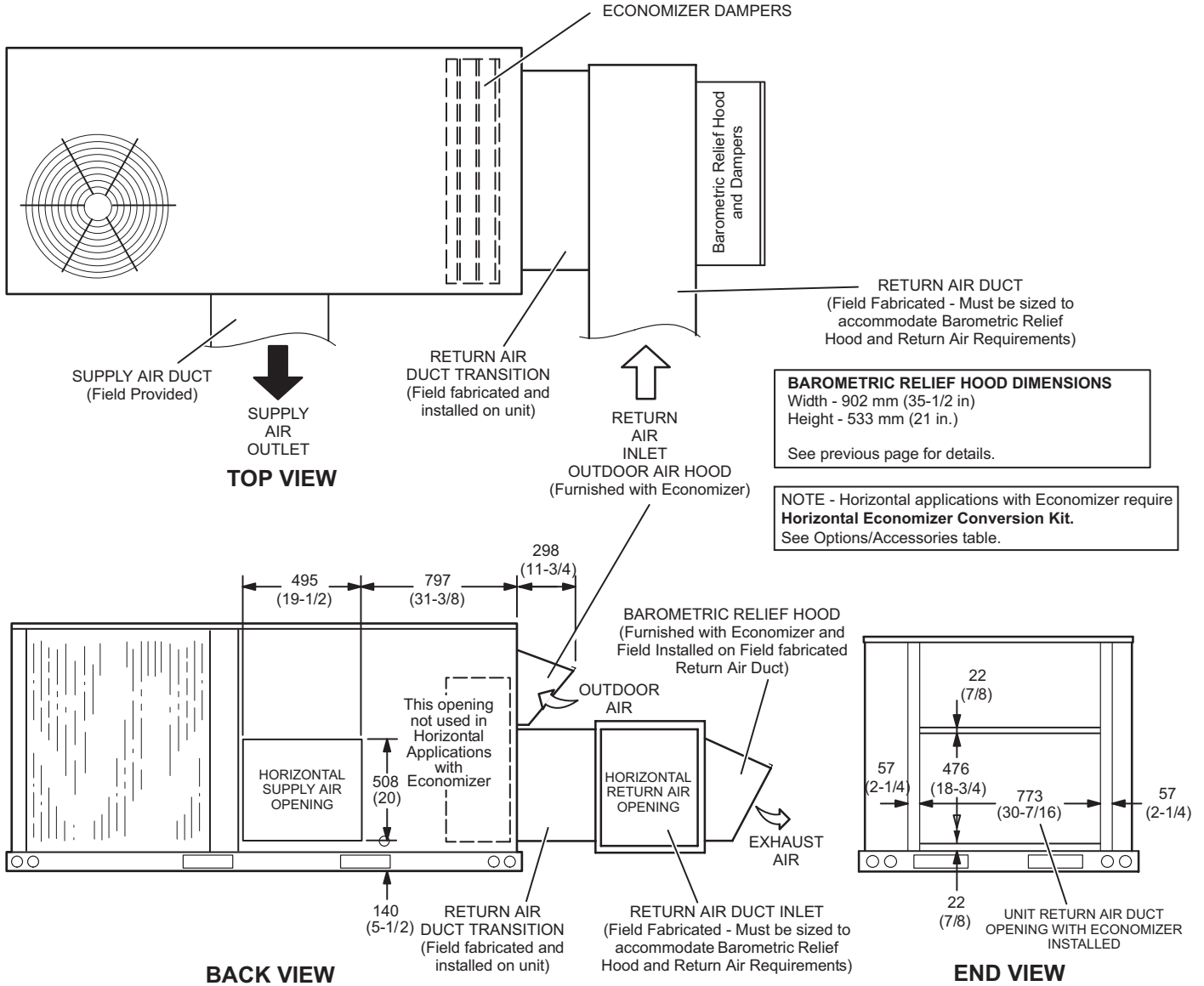

NOTE - Return Air Duct and Transition must be supported.

DIMENSIONS - ACCESSORIES

HYBRID ROOF CURBS - DOUBLE DUCT OPENING - STANDARD AND FULL PERIMETER

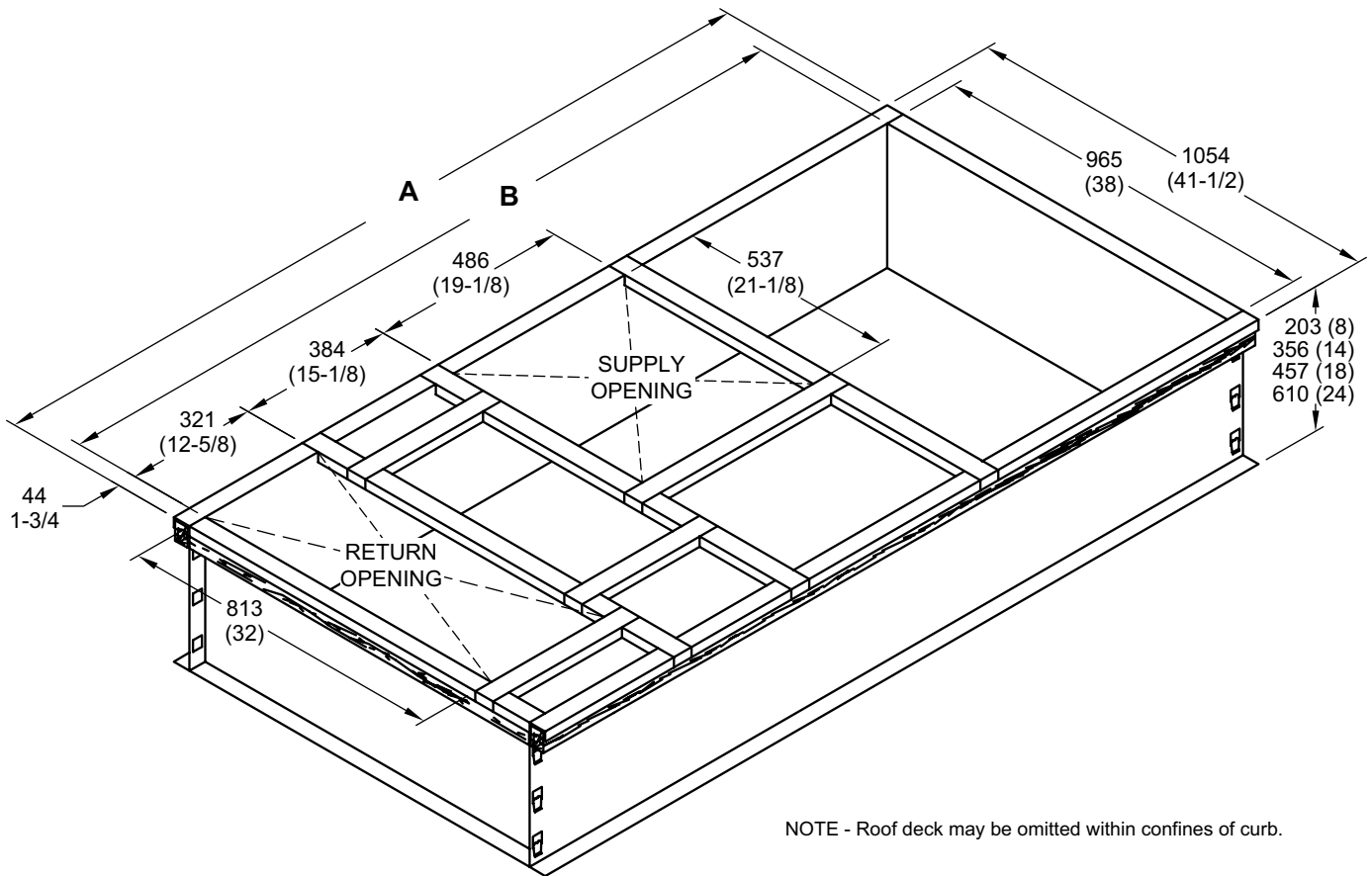

TYPICAL FLASHING DETAIL FOR ROOF CURB

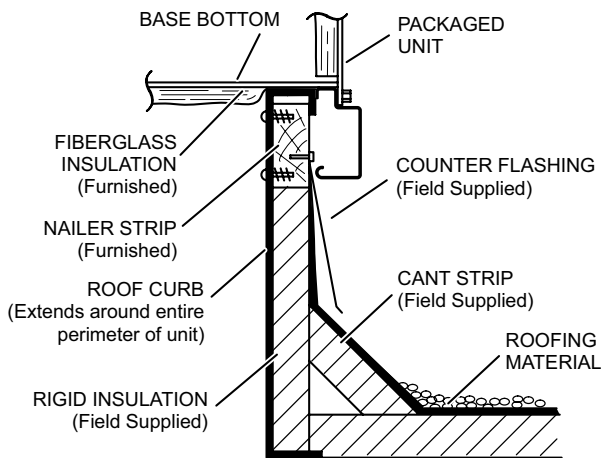

DETAIL ROOF CURB

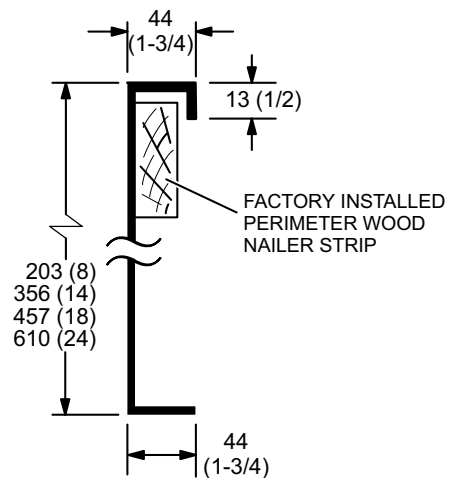

Model No.	A		B	
	mm	in.	mm	in.
Standard - ¹ 072	2026	79-3/4	1937	76-1/4
Full Perimeter - 072	2356	92-3/4	2267	89-1/4

¹ 072 models can be used on smaller 2026 mm (79-3/4 in.) roof curbs (not full perimeter) with 400 mm (15-3/4 in.) overhang at condenser end of unit. See dimension drawing on page 24.

DIMENSIONS - ADJUSTABLE PITCH CURB

ADJUSTABLE PITCH CURBS - DOUBLE DUCT OPENING

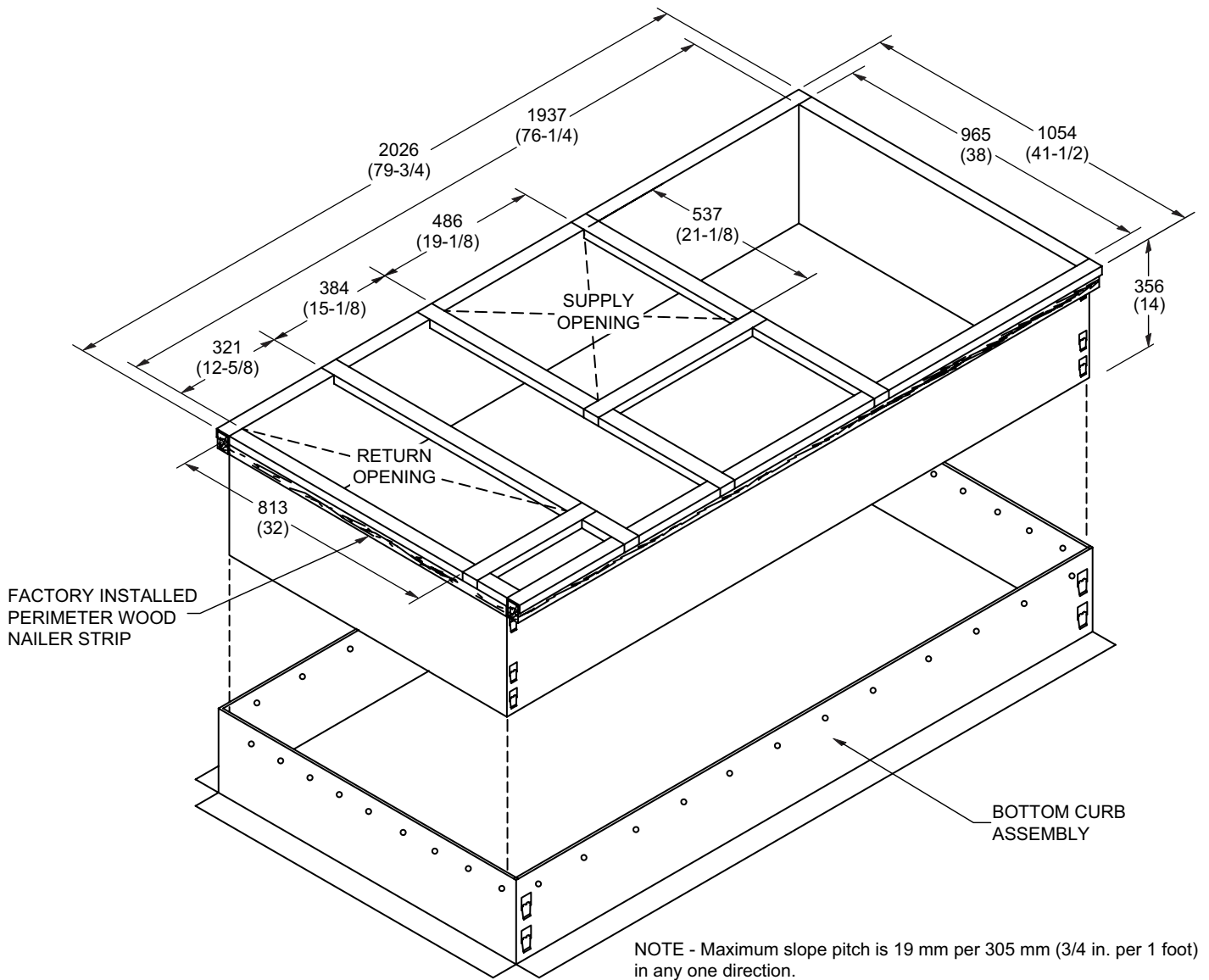

TYPICAL FLASHING DETAIL FOR ROOF CURB

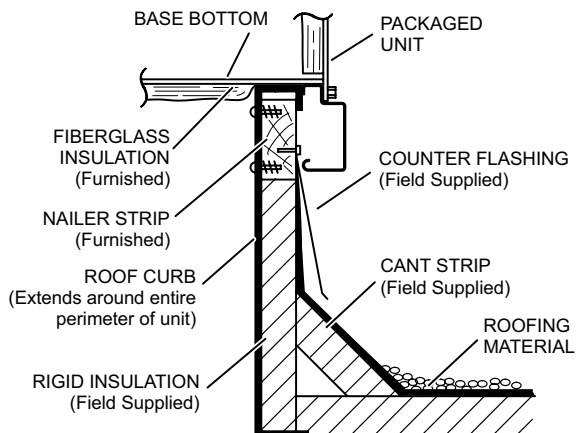

DETAIL ROOF CURB

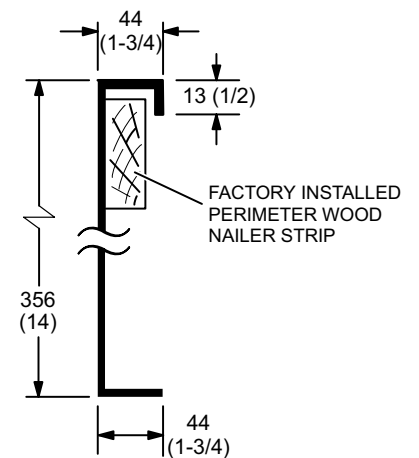

DIMENSIONS - ACCESSORIES

072 MODELS - SHOWING OVERHANG ON SMALLER 2026 MM LENGTH ROOF CURBS
(Not Full Perimeter)

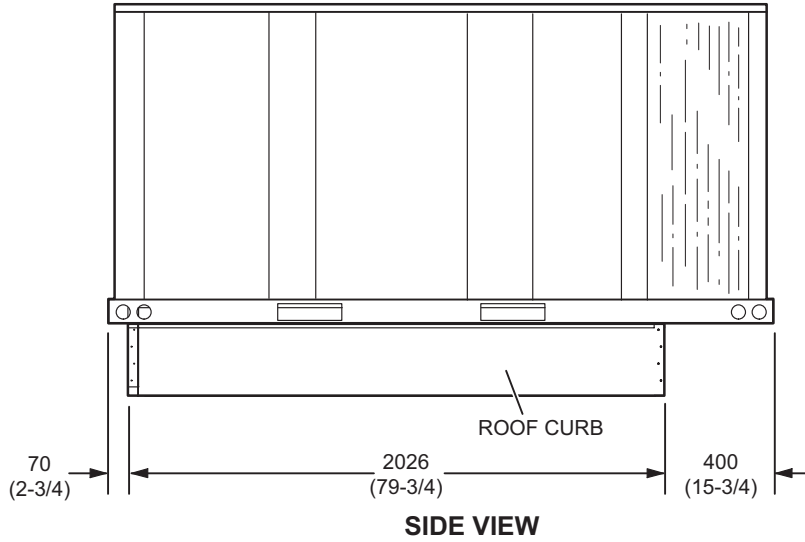

TRANSITIONS

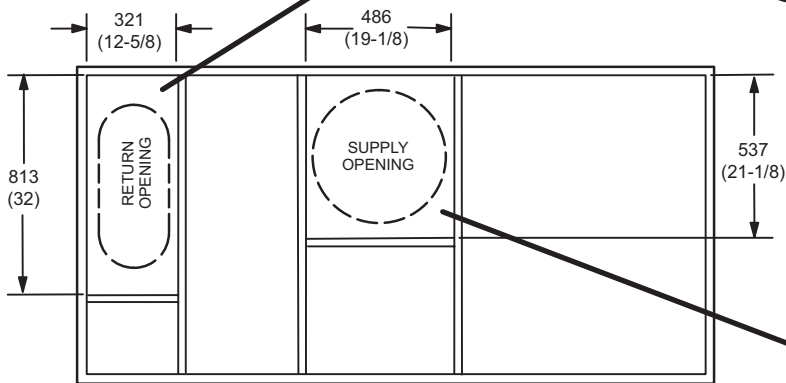

T1TRAN10AN-1 - FOR 457 mm (18 inch) DUCT
T1TRAN20N-1 - FOR 508 mm (20 inch) DUCT

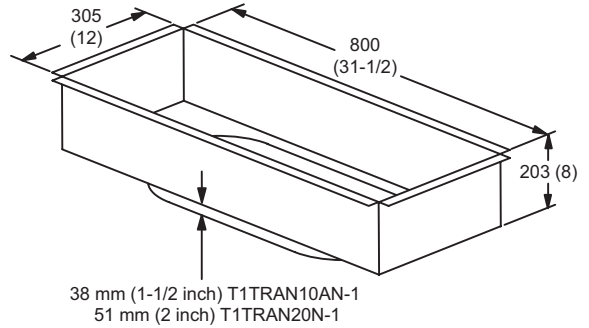

38 mm (1-1/2 inch) T1TRAN10AN-1
51 mm (2 inch) T1TRAN20N-1

T1TRAN10AN-1 - FOR 457 mm (18 inch) DUCT
T1TRAN20N-1 - FOR 508 mm (20 inch) DUCT

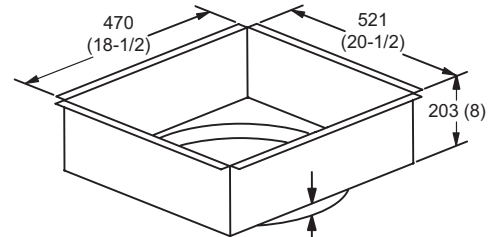

38 mm (1-1/2 inch) T1TRAN10AN-1
51 mm (2 inch) T1TRAN20N-1

DIMENSIONS - ACCESSORIES

COMBINATION CEILING SUPPLY AND RETURN DIFFUSERS

STEP-DOWN CEILING DIFFUSER

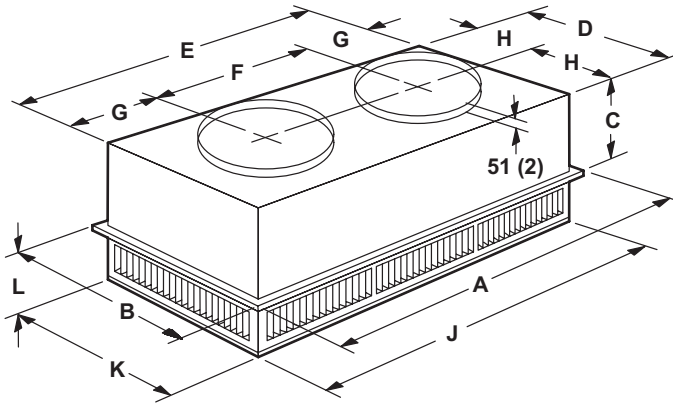

Model Number		RTD11-95S
A	mm	1159
	in.	47-5/8
B	mm	752
	in.	29-5/8
C	mm	365
	in.	14-3/8
D	mm	699
	in.	27-1/2
E	mm	1158
	in.	45-1/2
F	mm	572
	in.	22-1/2
G	mm	292
	in.	11-1/2
H	mm	349
	in.	13-3/4
J	mm	1156
	in.	45-1/2
K	mm	699
	in.	27-1/2
L	mm	206
	in.	8-1/8
Duct Size	mm	508 round
	in.	20 round

FLUSH CEILING DIFFUSER

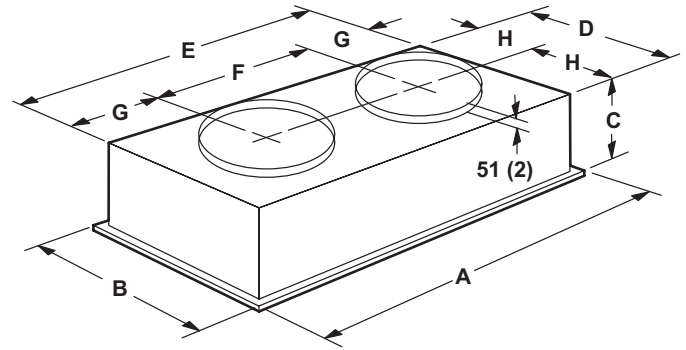

Model Number		FD11-95S
A	mm	1159
	in.	47-5/8
B	mm	752
	in.	29-5/8
C	mm	422
	in.	16-5/8
D	mm	686
	in.	27
E	mm	1143
	in.	45
F	mm	572
	in.	22-1/2
G	mm	286
	in.	11-1/4
H	mm	343
	in.	13-1/2
Duct Size	mm	508 round
	in.	20 round

REVISIONS

Sections	Description of Change
Options/Accessories	Catalog numbers revised for: Disconnects Economizers Gravity Exhaust Dampers Power Exhaust Single Enthalpy Smoke Detectors



Visit us at www.lennox.com

For the latest technical information, www.lennoxcommercial.com

Contact us at 1-800-4-LENNOX

NOTE - Due to Lennox' ongoing commitment to quality, Specifications, Ratings and Dimensions subject to change without notice and without incurring liability. Improper installation, adjustment, alteration, service or maintenance can cause property damage or personal injury. Installation and service must be performed by a qualified installer and servicing agency.

©2021 Lennox Industries, Inc.