

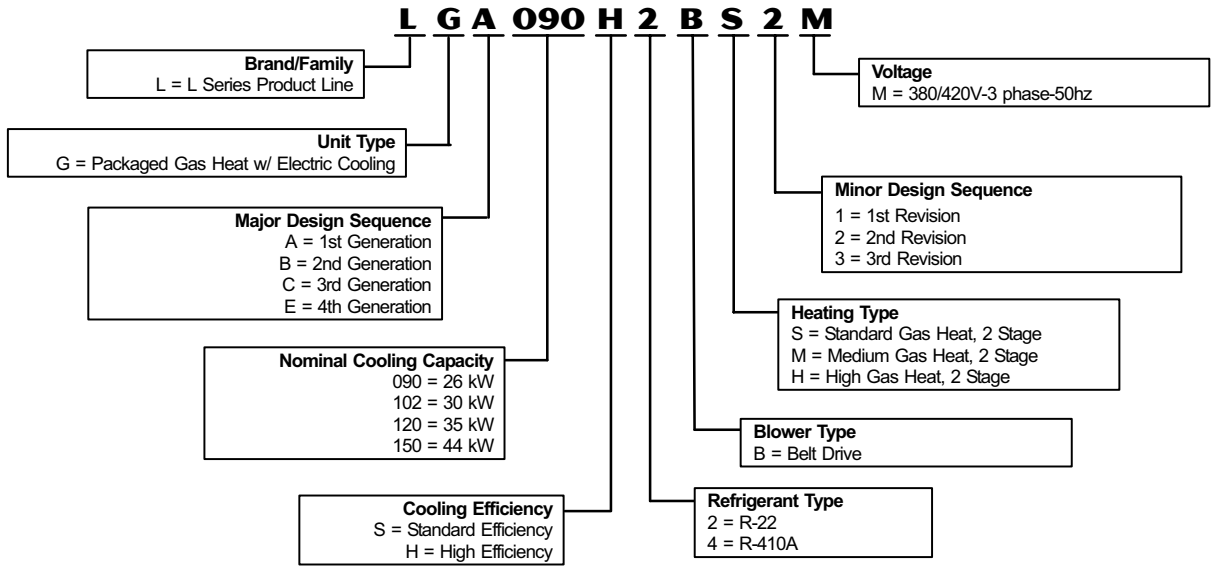

Nominal Cooling Capacity - 26 to 44 kW
Net Cooling Capacity - 23.9 to 37.7 kW
Gas Input Heat Capacity - 24.8 to 61.5 kW

MODEL NUMBER IDENTIFICATION



CONTENTS

Accessory Air Resistance	Page 18
Blower Performance	Pages 17-19
Cooling Ratings	Pages 11-16
Dimensions	Pages 24-30
Electrical Data	Pages 20-21
Features and Benefits	Pages 2-6
High Altitude Information	Page 11
Model Number Identification	Page 1
Options / Accessories	Pages 6-8
Specifications	Pages 9-10
Sound Data	Page 19
Temperature Control Systems	Page 22
Unit Clearances	Page 21
Weights	Page 23

FEATURES AND BENEFITS

PERFORMANCE / QUALITY

Components bonded for grounding to meet safety standards for servicing required by Underwriters Laboratories (UL) and the International Electrotechnical Commission (IEC). Cooling performance is rated at test conditions included in Air-Conditioning and Refrigeration Institute (ARI) Standard 340/360-2004 while operating at rated voltage and air volumes. International Organization for Standardization (ISO) 9001 Registered Manufacturing Quality System.

CABINET

Construction

Heavy-gauge steel panels and full perimeter heavy-gauge galvanized steel base rail provides structural integrity for transportation, handling, and installation.

- 1 Base rails have rigging holes. Three sides of the base rail have fork slots. Raised edges around duct and power entry openings in the bottom of the unit provide additional protection against water entering the building.

Air-Flow Choice

Units are available in down-flow (vertical) or horizontal air flow configuration.

Duct Flanges

Horizontal supply duct flange is standard on all units.

- 2 Power/Gas Entry

Electrical and gas lines can be brought through the unit base or through horizontal access knock-outs.

- 3 Exterior Panels

Constructed of heavy-gauge, galvanized steel with a two-layer enamel paint finish.

- 4 Insulation

All panels adjacent to conditioned air are fully insulated with non-hygroscopic fiberglass insulation.

- 5 Unit base is fully insulated. The insulation also serves as an air seal to the roof curb, eliminating the need to add a seal during installation.

- 6 Access Panels

Hinged access panels are provided for the economizer/filter section, blower/heating section and the compressor/controls section.

All panels have seals and quarter-turn latching handles to provide a tight air and water seal.

REQUIRED SELECTIONS

Air Flow Configuration

Specify horizontal or down-flow.

OPTIONS/ACCESSORIES

Factory Installed

Corrosion Protection

Polymeric epoxy coating that is deposited by electrical transport (electrophoresis), using a process known as electrocoat (e-coat). Available for enhanced coil corrosion protection. Factory installed on the condenser coil, evaporator coil, or both.

Field Installed

Coil Guards

Painted, galvanized steel wire guards to protect outdoor coil. Not used with Hail Guards.

Grille Guards

Protects space between outdoor coils and main cabinet.

Hail Guards

Constructed of heavy gauge steel, painted to match cabinet, helps protect outdoor coils from hail damage. Not used with Coil Guards.

Horizontal Conversion Kit

Two piece duct cover in kit blocks off unit down flow supply air opening, horizontal return air opening panel (on unit) is moved to block off down flow return air opening for horizontal applications.

FEATURES AND BENEFITS

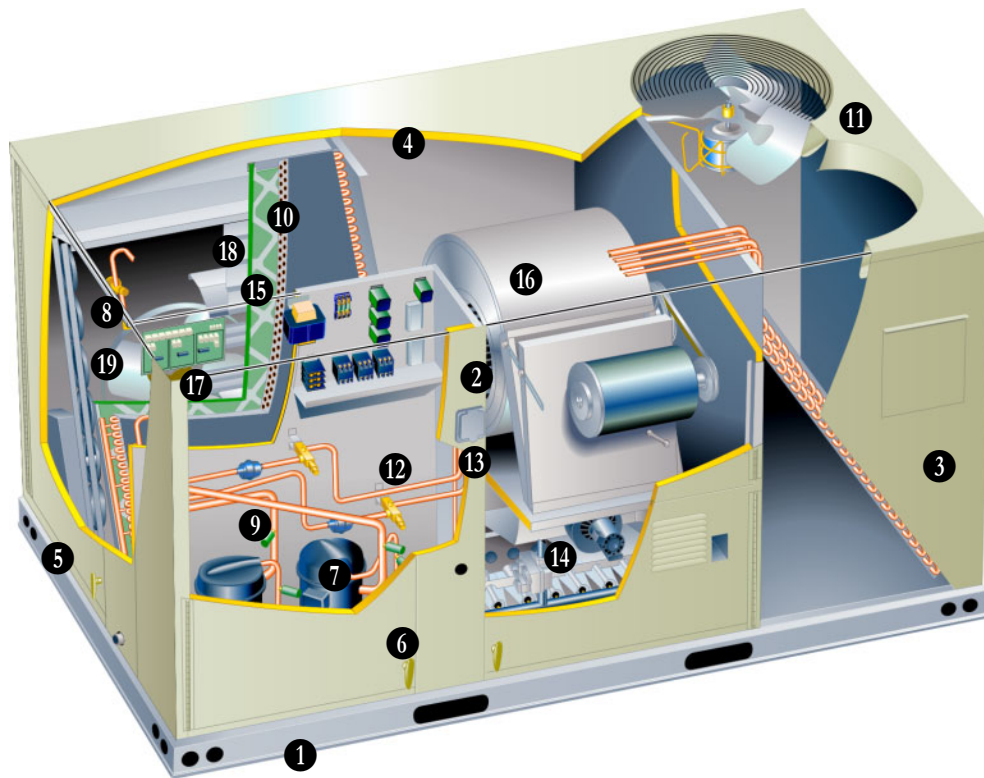

COOLING SYSTEM

Designed to maximize sensible and latent cooling performance at design conditions.

Two efficiency levels provide flexibility. System can operate from -18°C (0°F) to 52°C (125°F) without any additional controls.

7 Compressors

Resiliently mounted on rubber grommets for quiet operation. Scroll compressors on all models for high performance, reliability and quiet operation.

Compressor Crankcase Heaters

Protects against refrigerant migration that can occur during low ambient operation.

8 Thermal Expansion Valves

Assures optimal performance throughout the application range. Removable element head.

Filter/Driers

High capacity filter/drier protects the system from dirt and moisture.

9 High Pressure Switches

Protects the compressor from overload conditions such as dirty condenser coils, blocked refrigerant flow, or loss of outdoor fan operation.

Low Pressure Switches

Protects the compressor from low pressure conditions such as low refrigerant charge, or low/no air flow.

Freezestats

Protects the evaporator coil from damaging ice build-up due to conditions such as low/no air flow, or low/no refrigerant charge.

10 Coil Construction

Copper tube construction, enhanced rippled-edge aluminum fins, flared shoulder tubing connections, silver soldered construction for improved heat transfer. Factory leak tested.

Evaporator Coil

Face split with separate circuits. Cross row circuiting optimizes both sensible and latent cooling capacity.

Condenser Coil

Slab type on all models.

Condensate Drain Pan

Painted, galvanized pan with positive slope. Drain connection extends outside unit.

11 Outdoor Coil Fan Motors

Thermal overload protected, totally enclosed, permanently lubricated ball bearings, shaft up, wire basket mount.

Outdoor Coil Fans

Polyvinyl chloride (PVC) coated fan guard furnished.

REQUIRED SELECTIONS

Cooling Capacity

Specify the nominal cooling capacity of the unit.

Cooling Efficiency

Specify either standard or high efficiency.

Refrigerant Choice

Specify R-22 or R-410A refrigerant.

OPTIONS/ACCESSORIES

Factory Installed

12 Service Valves

Fully serviceable brass valves installed in discharge and liquid lines.

Factory or Field Installed

Condensate Drain Trap

Field installed only, may be factory enclosed to ship with unit. Available in copper or polyvinyl chloride (PVC).

ELECTRICAL

OPTIONS/ACCESSORIES

13 Factory or Field Installed

Disconnect Switch

Accessible from outside of unit, spring loaded weatherproof cover furnished.

FEATURES AND BENEFITS

HEATING SYSTEM

- 14 Aluminized steel inshot burners, direct spark ignition, electronic flame sensor, combustion air inducer, redundant automatic dual stage gas valve with manual shut-off.

Fan & Limit Controls

Factory installed, limit controls with fixed temperature setting.

Heat limit controls protect against overheating.

Safety Switches

Flame roll-out switches, flame sensor switches and combustion air inducer proving switches protect system operation.

All safety switches are monitored by the IMC unit controller and diagnostic errors are reported and recorded.

Heat Exchanger

Tubular construction, aluminized steel, life cycle tested.

Stainless Steel Heat Exchanger is required if mixed air temperature is below 7°C (45°F).

REQUIRED SELECTIONS

Gas Input - Order one:

24.8/33.4 kW (84 500/114 000 Btuh)

Standard Heat Gas Input

34.3/46.7 kW (117 000/159 500 Btuh)

Medium Heat Gas Input

45.7/61.5 kW (156 000/210 000 Btuh)

High Heat Gas Input

OPTIONS/ACCESSORIES

Factory Installed

Low Temperature Vestibule Heater

Electric heater automatically controls minimum temperature in gas burner compartment when temperature is below -40°C (-40°F).

Stainless Steel Heat Exchanger

Required if mixed air temperature is below 7°C (45°F).

Factory or Field Installed

Field Installed

Combustion Air Intake Extensions

Recommended for use with existing flue extension kits in areas where high snow drifts can block intake air

LPG/Propane Kit

Conversion kit to field changeover units from Natural Gas to LPG/Propane.

Vertical Vent Extension Kit

For high snow areas or when vent is too close to fresh air intake.

INDOOR AIR QUALITY

15 Air Filters

Disposable 51 mm (2 inch) filters furnished as standard.

OPTIONS/ACCESSORIES

Factory or Field Installed

Healthy Climate® High Efficiency Air Filters

Disposable MERV 11 (Minimum Efficiency Reporting Value based on ASHRAE 52.2) efficiency 51 mm (2 inch) pleated filters.

Healthy Climate® High Efficiency Air Filters

Disposable MERV 15 (Minimum Efficiency Reporting Value based on ASHRAE 52.2) efficiency 51 mm (2 inch) pleated filters.

Indoor Air Quality (CO₂) Sensor

Monitors CO₂ levels, reports to IMC board which adjusts economizer dampers as needed.

16 BLOWER

A wide selection of supply air blower options are available to meet a variety of air flow requirements.

Motor

Overload protected, equipped with ball bearings.

Belt drive motors are offered on all models and are available in several different sizes to maximize air performance.

Supply Air Blower

Forward curved blades, double inlet, blower wheel is statically and dynamically balanced, ball bearings, adjustable pulley (allows speed change), blower assembly slides out of unit for servicing.

Ordering Information

Specify motor horsepower and drive kit number when base unit is ordered.

See Blower Data table for specifications.

REQUIRED SELECTIONS

Supply Air Blower

Order Standard or High Efficiency Blower motor (See Blower Data Table for specifications).

Order one drive kit, see Drive Kit Specifications Table.

SERVICEABILITY

Designed to streamline general maintenance and decrease troubleshooting time.

Diagnostics

IMC diagnostic codes pinpoint problems, minimizing troubleshooting time.

Marked & Color-Coded Wiring

All electrical wiring is color-coded and marked to identify which components it is connecting.

Electrical Plugs

Positive connection electrical plugs are used to connect common accessories or maintenance parts for easy removal or installation.

Toolless, Hinged Access Panels

Large access panels are hinged and have quarter-turn, latching handles for quick and easy access to maintenance areas.

Blower Access

Blower assembly slides out of the unit for easy access.

Thermal Expansion Valves

Thermal expansion valves (TXVs) are located near the perimeter of the unit for easier access.

Removable element head allows change out of element and bulb without removing the TXV.

Coil Cleaning

Slab coils allow for easy cleaning. Doors at each end of the coil compartment allow access to clean coils from the inside.

Standard Components

A large number of common maintenance parts are standard throughout the entire range of sizes, reducing the need to carry a lot of different parts to the job or in inventory.

Compressor Compartment

Compressors are located near the perimeter of the unit for easier access. Compressors are isolated from the condenser air flow allowing system operation checks to be done without changing the air flow across the outdoor coils.

Service Valves (optional)

Optional factory installed liquid and discharge service valves allow refrigerant to be isolated to the high side for service work on the low side of the refrigeration system.

CONTROLS

17 INTELLIGENT UNIT CONTROLLER

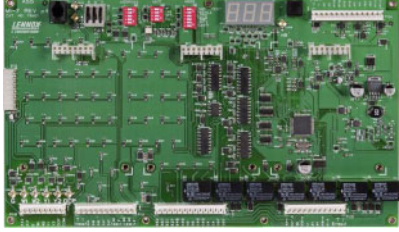

The Integrated Modular Controller (IMC) is a solid-state microprocessor-based control board that provides flexible control of all unit functions.

All control voltage is provided via a 24V (secondary) transformer with built-in circuit breaker protection.

Built-in functions include:

Blower On/Off Delay - Adjustable time delay between blower on and off.

Built-in Control Parameter Defaults - No programming required.

Compressor Time-Off Delay - Adjustable time delay between compressor shutoff and start up.

DDC Compatible - Various third party DDC controllers can be factory or field installed. Refer to the Unit Controllers section for details.

Dirty Filter Switch Input - When a Dirty Filter Switch is installed, the IMC will signal when the indoor blower static pressure increases, indicating a dirty filter condition. Switch is optional and can be factory or field installed.

Discharge Air Temperature Control - The IMC will cycle up to 4 stages of heating or cooling to maintain the discharge air setpoints for heating or cooling. Optional sensor for remote field installation in the supply duct.

Display/Sensor Readout - Displays control parameters, diagnostic codes, and sensor readings. The IMC unit controller displays temperature readings from return air, supply air, and outdoor air sensors that are furnished as standard on all L Series units. IMC will also display readings from optional sensors such as zone sensors, CO₂ sensors or relative humidity sensors.

Economizer Control Choice - The economizer is controlled by an add-on board to the IMC. The economizer control board has several choices for controlling the economizer. See Economizer / Outdoor Air / Exhaust Options.

Fresh Air Tempering - Provides heating and cooling as needed to maintain the supply air temperature within a comfort range, regardless of the thermostat demand. Sensor ships with unit but must be field installed in the supply air duct. Requires change to IMC (ECTO) parameter in the field to activate this mode of operation.

Extensive Unit Diagnostics - The IMC monitors all sensors and functions related to unit operation to provide critical information. The IMC will display detailed diagnostic information with over 90 diagnostic codes to pinpoint any problems and reduce troubleshooting time. All diagnostic codes are listed inside control access panel for easy reference.

Exhaust Fan Control Modes - Fans controlled by fresh air damper position or building static differential pressure transducer.

Permanent Diagnostic Code Storage - Maintains diagnostic codes through a power failure.

Field Changeable Control Parameters - Over 200 different control parameters allow customization of the unit operation by changing delays, cooling stages, deadbands, and setpoints.

Indoor Air Quality Input - The IMC is Demand Control Ventilation ready from the factory (optional field installed CO₂ sensor required). Two modes of operation are available: setpoint and proportional.

1 - Setpoint - Opens the economizer dampers to full position when CO₂ setpoint level is reached.

2 - Proportional - Opens the dampers at the first set point and gradually increases it as the CO₂ level increases until the second setpoint is reached.

Low Ambient Controls - Allows unit cooling operation down to -17°C (0°F).

Gas Valve Time Delay Between First and Second Stage - Allows gradual increase of input rate.

Minimum Compressor Run Time - Ensures proper oil return to the compressor.

Network Capable - The IMC can be daisy chained to other L Series units using twisted pair wire.

Night Setback Mode - Adjusts setpoints, closes outdoor air dampers and operates the blower on demand, may be customized for special requirements.

Return Air Temperature Limit Control - Allows the user to override the demands based upon the return air temperature during either heating or cooling operation. Helps protect against abnormal operating conditions in the event of a room sensor or thermostat failure.

Safety Switch Input - Normally-closed digital input allows the IMC to respond to a external safety switch trip (phase protector, low voltage, etc.) shutting down unit operation.

Service Relay Output - Digital output can indicate a critical error has occurred to an external control device. Can also be configured to energize based on relative humidity, indoor air quality, outdoor air temperature or unit operation.

Smoke Alarm Mode - Control board has four choices for responding to a smoke alarm.

1 - Unit Off - unit will turn off.

2 - Positive Pressure - blower is energized, exhaust fan is de-energized, and the outdoor air dampers are opened.

3 - Negative Pressure - blower is energized, exhaust fan is energized, and the outdoor air dampers are closed.

4 - Purge - blower is energized, exhaust fan is energized, and the outdoor air dampers are opened.

Staging - 2 heat/2 cool. Capable of up to 4 heat/4 cool with zone sensor or third party DDC control system.

“Strike Three” Protection - Ends cooling or heating operation when any of the following occurs three times (adjustable) within a thermostat cycle: low pressure trip, high pressure trip, heat limit trip, or freeze-stat trip.

Gas Reheat - Control parameter option that allows simultaneous heating and cooling operation for controlling humidity for process air applications such as supermarkets. Field installed relative humidity sensor or dehumidistat can be used.

Thermostat Bounce Delay - Protects compressor from short cycling when mechanical thermostat is used.

Warm-up Mode Delay - Adjustable time that the economizer dampers are kept in the closed position during morning warm-up.

On-Board User Interface - Push-button, DIP switches used with three-digit display readout for field adjustment of control parameters. LED indicators for each thermostat input.

PC Interface - PC with optional Unit Controller software may be used to field or remotely adjust parameters, read alarms, or display unit status.

Zone Sensor Operation - Controls zone temperature with up to 4 stages of heating or cooling with optional zone sensor.

FEATURES AND BENEFITS

CONTROLS - CONT.

OPTIONS / ACCESSORIES

Factory or Field Installed

Blower Proving Switch

Monitors blower operation, shuts down unit if blower fails. Factory installed.

Dirty Filter Switch

Senses static pressure increase indicating dirty filter condition.

Fresh Air Tempering

Used in applications with high outside air requirements. The IMC energizes the first stage heat as needed to maintain a minimum supply air temperature for comfort, regardless of the thermostat demand. When ordered as a factory option, the sensor ships with the unit but must be field installed.

Smoke Detector

Photoelectric type, installed in supply air section or return air section or both sections

Thermostats

Control system and thermostat options. Aftermarket unit controller options. See See Page 22.

Field Installed

Humidity Sensor Kit, Remote Mounted

Humidity sensor required with Supermarket reheat field selectable option.

OPTIONS / ACCESSORIES

ECONOMIZER/OUTDOOR AIR/EXHAUST OPTIONS

Factory or Field Installed

18 Economizer

Parallel gear driven action return air and outdoor air dampers, plug-in connections to unit, nylon bearings, neoprene seals, 24 volt fully modulating spring return motor, adjustable minimum damper position, damper assembly slides in unit, outdoor air hood must be ordered separately, optional down-flow barometric relief dampers available, choice of economizer controls. The IMC add-on board for economizer control is included with the economizer. Control board has four choices for controlling the economizer (DIP switch selections).

1 - Differential Sensible Control

Factory setting. Uses outdoor air and return air sensors that are furnished with the unit. The IMC compares outdoor air and return air and using setpoints, enables the economizer when the outdoor air temperature is below the configured setpoint and cooler than return air.

NOTE - Differential Sensible Control can be configured in the field to provide Offset Differential Sensible Control or Single Sensible Control.

In Offset Differential Sensible Control mode, the economizer is enabled if the temperature differential (offset) between outdoor air and return air reaches the configured setpoint.

In Single Sensible Control mode, the economizer is enabled when outdoor air temperature falls below the configured setpoint.

2 - Global Control - The IMC communicates with a DDC system with one global sensor (enthalpy or sensible) to determine whether outside air is suitable for free cooling on all units connected to the control system. Sensor must be field provided.

3 - Single Enthalpy Control - Outdoor air enthalpy sensor enables economizer if the outdoor enthalpy is less than the setpoint of the board. Factory installed.

4 - Differential Enthalpy Control

Two solid-state enthalpy sensors allow the economizer control board to select between outdoor air or return air, whichever has lower enthalpy. Factory installed.

Down-Flow Barometric Relief Dampers

Allows relief of excess air, aluminum blade dampers prevent blow back and outdoor air infiltration during off cycle, bird screen furnished, see Field Installed section (below) for damper hood

Outdoor Air Damper Section

Linked mechanical dampers, 0 to 25% (fixed) outdoor air adjustable, installs in unit, outdoor air hood must be ordered separately. Motorized model features fully modulating spring return damper motor with plug-in connection. Manual model features a slide damper.

Minimum mixed air temperature in heating mode: -1°C (30°F).

Maximum mixed air temperature in cooling mode: 32°C (90°F).

Outdoor Air Hood

Required with LAREMD Economizer, LAOAD and LAOADM Outdoor Air Damper Sections, two cleanable aluminum mesh fresh air filter furnished.

19 Power Exhaust Fan

Installs external to unit for down-flow applications only with economizer option, provides exhaust air pressure relief, interlocked to run when supply air blower is operating, fan runs when outdoor air dampers are 50% open (adjustable), motor is overload protected, steel cabinet and hood painted to match unit. Fan is 508 mm (20 in.) in diameter with 5 fan blades. Total air volume is 1650 L/s (3500 cfm) at 0 Pa (in. wg.). 249 (1/3 hp) motor. 300 Watts total input.

Field Installed

Down-Flow Barometric Relief Damper Hood

Field installed only.

Horizontal Barometric Relief Dampers

Allows relief of excess air, aluminum blade dampers prevent blow back and outdoor air infiltration during off cycle, field installed in return air duct, bird screen and hood furnished, two dampers per order number.

CEILING DIFFUSERS

Ceiling Diffusers (Flush or Step-Down)

Aluminum grilles, large center grille, insulated diffuser box with flanges, hanging rings furnished, interior transition (even air flow), internally sealed (prevents recirculation), adapts to T-bar ceiling grids or plaster ceilings.

Transitions (Supply and Return)

Used with diffusers, installs in roof curb, galvanized steel construction, flanges furnished for duct connection to diffusers, fully insulated.

ROOF CURBS

Roof Curb, Down-Flow

Nailer strip furnished, mates to unit, US National Roofing Contractors Approved, shipped knocked down. Available in 203, 356, 457 and 610 mm (8, 14, 18 and 24 inch) heights. Standard roof curb corners fasten together with furnished hardware. Cliplock curbs use interlocking tabs to fasten together. No tools required.

OPTIONS / ACCESSORIES

Item	Catalog No.	090	102	120	150	
COOLING SYSTEM						
Condensate Drain Trap	Copper - LTACDKC09/36	76M19	⊗	⊗	⊗	⊗
	Polyvinyl Chloride (PVC) - LTACDKP09/36	76M18	⊗	⊗	⊗	⊗
Corrosion Protection	Factory	○	○	○	○	
Efficiency	Standard	Factory	○	○	○	○
	High	Factory	○	○	○	○
Refrigerant Type	R-22	Factory	○	○	○	○
	R-410A	Factory	○	○	○	○
Service Valves	Factory	○	○	○	○	
Stainless Steel Condensate Drain Pan	Factory	○	○	○	○	
HEATING SYSTEM						
Combustion Air Intake Extensions	LTACAIK10/15	89L97	x	x	x	x
Gas Heat Input (2 Stage)	Standard - 33.4 kW input	Factory	○	○	○	○
	Medium - 46.7 kW input	Factory	○	○	○	○
	High - 61.5 kW input	Factory	○	○	○	○
Low Temperature Vestibule Heater	Factory	○	○	○	○	
LPG/Propane Conversion Kits	33.4 kW input - LTALPGK-130	72M94	x	x	x	x
	46.7 kW input - LTALPGK-180	72M95	x	x	x	x
	61.5 kW input - LTALPGK-240	72M96	x	x	x	x
Stainless Steel Heat Exchanger	Factory	○	○	○	○	
Vertical Vent Extension	LTAWEK10/15	73M72	x	x	x	x
BLOWER - SUPPLY AIR						
Constant Air Volume	1.5 kW (2 hp) Standard Efficiency	Factory	○	○	○	○
	2.2 kW (3 hp) Standard Efficiency	Factory	○	○	○	○
	3.7 kW (5 hp) Standard Efficiency	Factory	○	○	○	○
CABINET						
Coil Guards		88K51	x	x	x	x
Grille Guards		86K29	x	x	x	x
Hail Guards		88K24	x	x	x	x
Horizontal Discharge Conversion Kit	LTHSDKGC10/15	56K53	x	x	x	x
CONTROLS						
Blower Proving Switch	C0SWCH01AE1-	30K49	⊗	⊗	⊗	⊗
Dirty Filter Switch	C0SWCH00AE1-	30K48	⊗	⊗	⊗	⊗
Fresh Air Tempering	C0SND03AE-1	45L78	⊗	⊗	⊗	⊗
Smoke Detector - Supply	LTSASDK10/36	70K87	⊗	⊗	⊗	⊗
Smoke Detector - Return	LTARSDK10/30	70K86	⊗	⊗	⊗	⊗
ELECTRICAL						
Voltage - 50 hz with neutral	380/420V - 3 phase	Factory	○	○	○	○
Disconnect Switch		84M13	⊗	⊗	⊗	⊗

NOTE - The catalog and model numbers that appear here are for ordering field installed accessories only.

⊗ - Field Installed or Configure to Order (factory installed)

○ - Configure to Order (Factory Installed)

X - Field Installed.

OPTIONS / ACCESSORIES

Item	Catalog No.	090	102	120	150	
INDOOR AIR QUALITY						
Air Filters						
Healthy Climate® High Efficiency Air Filters 457 x 610 x 51 mm - Order 4 per unit	MERV 11 - C1FLTR20B-1-	97L86	⊗	⊗	⊗	⊗
	MERV 15 - C1FLTR50B-1-	28W04	x	x	x	x
Indoor Air Quality Sensors						
CO ₂ Sensor - white case w/ display	C0SNSR50AE1L	77N39	x	x	x	x
CO ₂ Sensor - white case, no display	C0SNSR52AE1L	87N53	x	x	x	x
CO ₂ Sensor - black case w/ display	C0SNSR51AE1L	87N52	x	x	x	x
CO ₂ Sensor - black case, no display	C0SNSR53AE1L	87N54	x	x	x	x
CO ₂ Sensor Duct Mounting Kit	C0MISC19AE1-	85L43	x	x	x	x
Aspiration Box for duct mounting Sensor	C0MISC16AE1-	90N43	x	x	x	x
Handheld CO ₂ Monitor	LTAIAQSHM03/36	70N93	x	x	x	x
ECONOMIZER						
Economizer						
Economizer - Order Hood Separately	LAREMD10/15	53K51	⊗	⊗	⊗	⊗
Outdoor Air Hood (down-flow) (2) 406 x 635 x 25 mm	LAOAH10/15	53K05	⊗	⊗	⊗	⊗
Economizer Controls						
Differential Enthalpy	C1SNSR07AE	86M33	⊗	⊗	⊗	⊗
Single Enthalpy	C1SNSR06AE	86M32	⊗	⊗	⊗	⊗
Global, Enthalpy	Sensor Field Provided	Factory	○	○	○	○
Differential Sensible	Furnished	Factory	○	○	○	○
Barometric Relief						
Down-Flow Barometric Relief Dampers - Order Hood Separately	LAGED10/15	53K03	⊗	⊗	⊗	⊗
Hood for Down-Flow LAGED	LAGEH09/15	88K79	x	x	x	x
Horizontal Barometric Relief Dampers - Hood Furnished	LAGEDH03/15	53K04	x	x	x	x
OUTDOOR AIR						
Outdoor Air Dampers						
Damper Section (down-flow) - Motorized - Order Hood Separately	LAOADM10/15	53K53	⊗	⊗	⊗	⊗
Damper Section (down-flow) - Manual - Order Hood Separately	LAOAD10/15	66K69	⊗	⊗	⊗	⊗
Outdoor Air Hood (down-flow) (2) 406 x 635 x 25 mm	LAOAH10/15	53K05	⊗	⊗	⊗	⊗
Power Exhaust						
Standard Static	LAPEF10/15	73M33	⊗	⊗	⊗	⊗
ROOF CURBS						
ClipLock 1000						
203 mm (8 in.) height	C1CURB40B-1	26W31	x	x	x	x
356 mm (14 in.) height	LARMF10/15S-14	65K34	x	x	x	x
457 mm (18 in.) height	LARMF10/15S-18	65K35	x	x	x	x
610 mm (24 in.) height	LARMF10/15S-24	35K36	x	x	x	x
Standard						
356 mm (14 in.) height	LARMF10/15-14	53K50	x	x	x	x
610 mm (24 in.) height	LARMF10/15-24	49K54	x	x	x	x
CEILING DIFFUSERS						
Step-Down Order one	RTD11-95	29G04	x			
	RTD11-135	29G05		x	x	
	RTD11-185	29G06				x
Flush Order one	FD11-95	29G08	x			
	FD11-135	29G09		x	x	
	FD11-185	29G10				x
Transitions (Supply and Return) Order one	LASRT08/10	24L14	x			
	LASRT10/12	49K55		x	x	
	LASRT15	49K56				x
	LASRT15S	65K38				x

NOTE - The catalog and model numbers that appear here are for ordering field installed accessories only.

⊗ - Field Installed or Configure to Order (factory installed)

○ - Configure to Order (Factory Installed)

x - Field Installed.

SPECIFICATIONS

26 - 30 kW

General Data		26 kW			30 kW		
		LGC090S2B	LGA090H2B	LGA090H4B	LGC102S2B	LGA102H2B	LGA102H4B
Nominal kW							
Model No.							
Efficiency Type		Standard	High	High	Standard	High	High
Cooling Performance	Gross Cooling Capacity - kW (Btuh)	25.7 (87 700)	24.9 (84 900)	24.9 (84 900)	27.3 (93 100)	28.0 (95 700)	27.3 (93 200)
	¹ Net Cooling Capacity - kW (Btuh)	24.7 (84 300)	23.9 (81 500)	23.9 (81 500)	26.1 (89 000)	26.7 (91 500)	26.1 (89 100)
	ARI Rated Air Flow - L/s (cfm)	1415 (3000)	1370 (2900)	1370 (2900)	1605 (3400)	1510 (3200)	1510 (3200)
	² Sound Rating Number (dB)	88	88	88	88	88	88
	Total Unit Power (kW)	8.0	7.1	7.1	8.9	8.1	7.9
	¹ EER (Btuh/Watt)	10.5	11.4	11.4	10.0	11.3	11.3
	¹ Integrated Part Load Value (Btuh/Watt)	11.2	12.2	12.2	10.6	11.7	11.9
Refrigerant Type		R-22	R-22	R-410A	R-22	R-22	R-410A
Refrigerant Charge	Circuit 1 Furnished	2.72 kg (6 lbs. 0 oz.)	4.54 kg (10 lbs. 0 oz.)	4.76 kg (10 lbs. 8 oz.)	2.72 kg (6 lbs. 0 oz.)	4.76 kg (10 lbs. 8 oz.)	4.76 kg (10 lbs. 8 oz.)
	Circuit 2	2.72 kg (6 lbs. 0 oz.)	4.54 kg (10 lbs. 0 oz.)	4.76 kg (10 lbs. 8 oz.)	2.72 kg (6 lbs. 0 oz.)	4.76 kg (10 lbs. 8 oz.)	4.31 kg (9 lbs. 8 oz.)
Gas Heating Options Available - See page 11		Standard (2 Stage), Medium (2 Stage), or High (2 Stage)					
Compressor Type		Scroll (2)	Scroll (2)	Scroll (2)	Scroll (2)	Scroll (2)	Scroll (2)
Outdoor Coil	Net face area - m ² (sq. ft.)	2.72 (29.3) total			2.72 (29.3) total		
	Tube diameter - mm (in.)	9.5 (3/8)	9.5 (3/8)	9.5 (3/8)	9.5 (3/8)	9.5 (3/8)	9.5 (3/8)
	Number of rows	1	2	2	1	2	2
	Fins per meter (inch)	787 (20)	787 (20)	787 (20)	787 (20)	787 (20)	787 (20)
Outdoor Coil Fans	Motor Watts (hp)	(2) 249 (1/3)			(2) 249 (1/3)		
	Motor rev/min	896			896		
	Total Motor watts	535			535		
	Diameter - mm (in.)	(2) 610 (24)			(2) 610 (24)		
	Number of blades	3			3		
	Total air volume - L/s (cfm)	3145 (6665)			3145 (6665)		
Indoor Coil	Net face area - m ² (sq. ft.)	0.98 (10.5) total			0.98 (10.5) total		
	Number of rows	3			3		
	Tube diameter - mm (in.)	9.5 (3/8)			9.5 (3/8)		
	Fins per meter (inch)	551 (14)			551 (14)		
	Drain connection - no. & size	(1) 1 in. NPT coupling			(1) 1 in. NPT coupling		
	Expansion device type	Balanced Port Thermostatic Expansion Valve, removeable power head					
³ Indoor Blower and Drive Selection	Nominal motor output - voltage	1.5. 2.2 or 3.7 kW (2, 3, or 5 hp)					
	Motor - Drive kit	1.5 kW (2 hp) kit #1 - 567 - 771 rev/min kit #3 - 746 - 933 rev/min		2.2 kW (3 hp) kit #2 - 567 - 771 rev/min kit #4 - 746 - 933 rev/min kit #6 - 925 - 1163 rev/min		3.7 kW (5 hp) kit #4 - 746 - 933 rev/min kit #6 - 935 - 1163 rev/min	
	Wheel nominal diameter x width - mm (in.)	(1) 381 x 381 (15 x 15)			(1) 381 x 381 (15 x 15)		
Filters	Type of filter	Disposable					
	Number and size - mm (in.)	(4) 457 x 610 x 51 (18 x 24 x 2)					
Electrical characteristics - 50 Hz		380/420V - 3 phase					

NOTE - Net capacity includes evaporator blower motor heat deduction. Gross capacity does not include evaporator blower motor heat deduction.
¹ Rating test conditions are those included in Air-Conditioning and Refrigeration Institute (ARI) Standard 340/360 while operating at rated voltage and air volumes; 35°C (95°F) outdoor air temperature and 27°C (80°F) db/19°C (67°F) wb entering evaporator air; minimum external duct static pressure.
² Sound Rating Number rated in accordance with test conditions included in Air-Conditioning and Refrigeration Institute (ARI) Standard 270.
³ Using total air volume and system static pressure requirements determine from blower performance tables rev/min and motor output required. If motors of comparable output are used, be sure to keep within the service factor limitations outlined on the motor nameplate.

SPECIFICATIONS

35 - 44 kW

General Data		Nominal kW	35 kW			44 kW	
		Model No.	LGC120S2B	LGA120H2B	LGA120H4B	LGC150S2B	LGC150S4B
Efficiency Type		Standard	High	High	Standard	Standard	
Cooling Performance	Gross Cooling Capacity - kW (Btuh)	33.5 (114 400)	33.6 (114 700)	33.1 (112 900)	38.7 (132 100)	39.9 (136 200)	
	¹ Net Cooling Capacity - kW (Btuh)	31.9 (108 900)	32.2 (109 900)	31.7 (108 100)	36.6 (124 900)	37.7 (128 900)	
	ARI Rated Air Flow - L/s (cfm)	1795 (3800)	1700 (3600)	1700 (3600)	2005 (4250)	2005 (4250)	
	³ Sound Rating Number (dB)	88	88	88	88	88	
	Total Unit Power (kW)	10.5	9.8	9.7	13.3	13.2	
	¹ EER (Btuh/Watt)	10.4	11.2	11.2	9.4	9.8	
	² Integrated Part Load Value (Btuh/Watt)	10.6	11.7	11.9	9.3	10.0	
Refrigerant Type		R-22	R-22	R-410A	R-22	R-410A	
Refrigerant Charge Furnished	Circuit 1	4.53 kg (10 lbs. 0 oz)	5.22 kg (11 lbs. 8 oz)	4.77 kg (10 lbs. 8 oz)	6.35 kg (14 lbs. 0 oz)	5.90 kg (13 lbs. 0 oz)	
	Circuit 2	4.53 kg (10 lbs. 0 oz)	5.22 kg (11 lbs. 8 oz)	4.77 kg (10 lbs. 8 oz)	6.35 kg (14 lbs. 0 oz)	5.22 kg (11 lbs. 8 oz)	
Gas Heating Options Available - See below		Standard (2 Stage), Medium (2 Stage), or High (2 Stage)					
Compressor Type (No.)		Scroll (2)	Scroll (2)	Scroll (2)	Scroll (2)	Scroll (2)	
Outdoor Coil	Net face area - m ² (sq. ft.)	2.72 (29.3) total			2.47 (26.6) total		
	Tube diameter - mm (in.) - No. of rows	9.5 (3/8) - 2			9.5 (3/8) - 3		
	Fins per meter (inch)	787 (20)			787 (20)		
Outdoor Coil Fans	Motor Watts (horsepower)	(2) 249 (1/3)			(2) 372 (1/2)		
	Motor rev/min	896			896		
	Total Motor watts	535			878		
	Diameter - mm (in.) - no. of blades	(2) 610 (24) - 3			(2) 610 (24) - 3		
	Total air volume - L/s (cfm)	3145 (6665)			3535 (7500)		
Indoor Coil	Net face area - m ² (sq. ft.)	0.98 (10.5) total			0.98 (10.5) total		
	Tube diameter - mm (in.) - No. of rows	9.5 (3/8) - 4			9.5 (3/8) - 4		
	Fins per meter (inch)	551 (14)			551 (14)		
	Drain connection - no. & size	(1) 1 in. NPT coupling			(1) 1 in. NPT coupling		
	Expansion device type	Balanced Port Thermostatic Expansion Valve, removeable power head					
⁴ Indoor Blower and Drive Selection	Nominal motor output	1.5, 2.2, or 3.7 kW (2, 3, or 5 hp)					
	Motor - Drive kit	1.5 kW (2 hp) kit #1 - 567 - 771 rev/min kit #3 - 746 - 933 rev/min	2.2 kW (3 hp) kit #2 - 567 - 771 rev/min kit #4 - 746 - 933 rev/min kit #6 - 925 - 1163 rev/min	3.7 kW (5 hp) kit #4 - 746 - 933 rev/min kit #6 - 935 - 1163 rev/min			
	Wheel nominal diameter x width - mm (in.)	(1) 381 x 381 (15 x 15)					
Filters	Type of filter	Disposable					
	Number and size - mm (in.)	(4) 457 x 610 x51 (18 x 24 x 2)					
Electrical characteristics		380/420V - 50 hertz - 3 phase					

NOTE - Net capacity includes evaporator blower motor heat deduction. Gross capacity does not include evaporator blower motor heat deduction.

¹ Rating test conditions are those included in Air-Conditioning and Refrigeration Institute (ARI) Standard 340/360 while operating at rated voltage and air volumes; 35°C (95°F) outdoor air temperature and 27°C (80°F) db/19°C (67°F) wb entering evaporator air; minimum external duct static pressure.

² Integrated Part Load Value rated at 27°C (80°F) outdoor air temperature.

³ Sound Rating Number rated in accordance with test conditions included in Air-Conditioning and Refrigeration Institute (ARI) Standard 270.

⁴ Using total air volume and system static pressure requirements determine from blower performance tables rev/min and motor output required. If motors of comparable output are used, be sure to keep within the service factor limitations outlined on the motor nameplate.

SPECIFICATIONS - GAS HEAT

Gas Heating Performance	Heat Input Type		Standard (2 Stage)	Medium (2 Stage)	High (2 Stage)
	Input - kW (Btuh)	First Stage	24.8 (84 500)	34.3 (117 000)	45.7 (156 000)
		Second Stage	33.4 (114 000)	46.7 (159.500)	61.5 (210 000)
Output - kW (Btuh)	Second Stage	26.7 (91 200)	36.9 (126 000)	49.2 (168 000)	
Thermal Efficiency			81.0%		
Gas Supply Connections			3/4 in. npt		
Recommended Gas Supply Pressure - Natural			0.70 kPa (2.8 in. w.c.)		
LPG/Propane			1.97 kPa (7.9 in. w.c.)		

HIGH ALTITUDE DERATE

Units may be installed at altitudes up to 610 m (2000 feet) above sea level without any modification. At altitudes above 610 m (2000 feet), units must be derated to match gas manifold pressures shown in table below. NOTE - This is the only permissible derate for these units.

	Altitude		Gas Manifold Pressure				Input Rate	
	m	ft.	Natural Gas		LPG/Propane		kW	Btuh
			kPa	in. w.g.	kPa	in. w.g.		
Standard	610 - 1372	2001 - 4500	0.62	2.5	1.82	7.3	31.7	108 000
Medium	610 - 1372	2001 - 4500	0.62	2.5	1.82	7.3	43.7	149 000
High	610 - 1372	2001 - 4500	0.62	2.5	1.82	7.3	58.0	198 000

COOLING RATINGS

NOTE - For Temperatures and Capacities not shown in tables, see bulletin - Cooling Unit Rating Table Correction Factor Data in Miscellaneous Engineering Data section.

26 kW STANDARD EFFICIENCY COOLING CAPACITY - ONE COMPRESSOR OPERATING

LGC090S2

Entering Wet Bulb Temperature	Total Air Volume		Outdoor Air Temperature Entering Outdoor Coil																							
			18°C (65°F)						24°C (75°F)						29°C (85°F)						35°C (95°F)					
			Total Cooling Capacity		Comp Motor kW Input	Sensible To Total Ratio (S/T) Dry Bulb			Total Cooling Capacity		Comp Motor kW Input	Sensible To Total Ratio (S/T) Dry Bulb			Total Cooling Capacity		Comp Motor kW Input	Sensible To Total Ratio (S/T) Dry Bulb			Total Cooling Capacity		Comp Motor kW Input	Sensible To Total Ratio (S/T) Dry Bulb		
			kW	kBtuh		24°C 75°F	27°C 80°F	29°C 85°F	kW	kBtuh		24°C 75°F	27°C 80°F	29°C 85°F	kW	kBtuh		24°C 75°F	27°C 80°F	29°C 85°F	kW	kBtuh		24°C 75°F	27°C 80°F	29°C 85°F
17°C (63°F)	1.13	2400	13.7	46.6	2.26	.61	.78	.96	13.2	45.2	2.51	.62	.79	.97	12.8	43.7	2.80	.63	.81	.99	12.3	42.1	3.13	.64	.84	1.00
	1.41	3000	14.2	48.4	2.29	.66	.88	1.00	13.7	46.9	2.54	.68	.90	1.00	13.3	45.3	2.83	.70	.93	1.00	12.8	43.7	3.17	.71	.95	1.00
	1.70	3600	14.6	49.8	2.32	.74	.97	1.00	14.2	48.3	2.57	.75	.98	1.00	13.7	46.8	2.87	.78	1.00	1.00	13.2	45.2	3.20	.80	1.00	1.00
19°C (67°F)	1.13	2400	14.5	49.5	2.31	.48	.59	.73	14.0	47.9	2.57	.48	.60	.75	13.6	46.3	2.85	.49	.61	.77	13.0	44.5	3.19	.50	.62	.79
	1.41	3000	14.9	51.0	2.34	.51	.64	.84	14.4	49.3	2.59	.51	.65	.86	14.0	47.6	2.89	.52	.67	.88	13.4	45.8	3.22	.53	.69	.91
	1.70	3600	15.3	52.1	2.36	.54	.71	.93	14.8	50.4	2.62	.54	.73	.95	14.2	48.6	2.91	.55	.75	.97	13.7	46.7	3.24	.56	.77	.99
22°C (71°F)	1.13	2400	15.4	52.6	2.37	.36	.47	.57	14.9	50.9	2.63	.36	.47	.58	14.4	49.2	2.92	.36	.48	.59	13.9	47.3	3.26	.37	.48	.60
	1.41	3000	15.9	54.1	2.40	.37	.50	.62	15.3	52.3	2.66	.37	.50	.63	14.8	50.5	2.96	.38	.51	.64	14.2	48.5	3.29	.38	.52	.66
	1.70	3600	16.1	55.1	2.43	.38	.53	.68	15.6	53.2	2.69	.39	.54	.70	15.0	51.3	2.98	.39	.54	.72	14.4	49.3	3.31	.39	.56	.75

26 kW STANDARD EFFICIENCY COOLING CAPACITY - ALL COMPRESSORS OPERATING

LGC090S2

Entering Wet Bulb Temperature	Total Air Volume		Outdoor Air Temperature Entering Outdoor Coil																							
			27°C (80°F)						35°C (95°F)						43°C (110°F)						52°C (125°F)					
			Total Cooling Capacity		Comp Motor kW Input	Sensible To Total Ratio (S/T) Dry Bulb			Total Cooling Capacity		Comp Motor kW Input	Sensible To Total Ratio (S/T) Dry Bulb			Total Cooling Capacity		Comp Motor kW Input	Sensible To Total Ratio (S/T) Dry Bulb			Total Cooling Capacity		Comp Motor kW Input	Sensible To Total Ratio (S/T) Dry Bulb		
			kW	kBtuh		24°C 75°F	27°C 80°F	29°C 85°F	kW	kBtuh		24°C 75°F	27°C 80°F	29°C 85°F	kW	kBtuh		24°C 75°F	27°C 80°F	29°C 85°F	kW	kBtuh		24°C 75°F	27°C 80°F	29°C 85°F
17°C (63°F)	1.13	2400	24.9	85.1	5.32	.69	.84	.99	23.6	80.6	6.29	.70	.87	1.00	22.2	75.7	7.49	.72	.90	1.00	20.6	70.3	8.99	.75	.95	1.00
	1.41	3000	25.8	88.2	5.39	.74	.93	1.00	24.5	83.6	6.36	.77	.96	1.00	23.0	78.6	7.57	.80	.99	1.00	21.5	73.5	9.09	.84	1.00	1.00
	1.70	3600	26.7	91.0	5.45	.81	.99	1.00	25.4	86.5	6.43	.84	1.00	1.00	23.9	81.7	7.65	.87	1.00	1.00	22.4	76.3	9.17	.92	1.00	1.00
19°C (67°F)	1.13	2400	26.4	90.1	5.43	.54	.66	.80	25.0	85.3	6.40	.55	.68	.83	23.4	80.0	7.61	.56	.70	.87	21.7	74.0	9.12	.57	.73	.91
	1.41	3000	27.2	92.7	5.49	.57	.72	.89	25.7	87.7	6.47	.58	.74	.93	24.0	82.0	7.67	.60	.77	.96	22.3	76.0	9.18	.62	.81	.99
	1.70	3600	27.7	94.6	5.54	.60	.78	.97	26.2	89.3	6.51	.62	.81	.99	24.5	83.6	7.73	.64	.85	1.00	22.7	77.4	9.23	.66	.90	1.00
22°C (71°F)	1.13	2400	28.1	95.8	5.56	.40	.52	.64	26.6	90.6	6.54	.40	.53	.66	24.9	84.9	7.76	.41	.54	.68	23.0	78.6	9.27	.41	.56	.71
	1.41	3000	28.8	98.4	5.62	.41	.56	.70	27.2	92.8	6.61	.42	.57	.72	25.5	86.9	7.82	.42	.59	.75	23.6	80.4	9.33	.43	.61	.79
	1.70	3600	29.3	100.0	5.67	.42	.59	.76	27.7	94.4	6.65	.43	.61	.79	25.8	88.2	7.86	.44	.63	.83	23.9	81.6	9.38	.45	.66	.88

COOLING RATINGS

NOTE - For Temperatures and Capacities not shown in tables, see bulletin - Cooling Unit Rating Table Correction Factor Data in Miscellaneous Engineering Data section.

26 kW HIGH EFFICIENCY COOLING CAPACITY - ONE COMPRESSOR OPERATING

LGA090H2

Entering Wet Bulb Temperature	Total Air Volume		Outdoor Air Temperature Entering Outdoor Coil																							
			18°C (65°F)						24°C (75°F)						29°C (85°F)						35°C (95°F)					
			Total Cooling Capacity		Comp Motor kW Input	Sensible To Total Ratio (S/T) Dry Bulb			Total Cooling Capacity		Comp Motor kW Input	Sensible To Total Ratio (S/T) Dry Bulb			Total Cooling Capacity		Comp Motor kW Input	Sensible To Total Ratio (S/T) Dry Bulb			Total Cooling Capacity		Comp Motor kW Input	Sensible To Total Ratio (S/T) Dry Bulb		
			kW	kBtu/h		24°C 75°F	27°C 80°F	29°C 85°F	kW	kBtu/h		24°C 75°F	27°C 80°F	29°C 85°F	kW	kBtu/h		24°C 75°F	27°C 80°F	29°C 85°F	kW	kBtu/h		24°C 75°F	27°C 80°F	29°C 85°F
17°C (63°F)	1.13	2400	13.0	44.5	1.85	.65	.82	.99	12.7	43.2	2.09	.66	.84	1.00	12.3	41.8	2.36	.67	.86	1.00	11.8	40.3	2.66	.68	.88	1.00
	1.41	3000	13.5	46.2	1.86	.70	.92	1.00	13.1	44.8	2.10	.72	.94	1.00	12.7	43.4	2.37	.74	.96	1.00	12.3	41.9	2.67	.76	.99	1.00
	1.70	3600	14.0	47.7	1.86	.78	.99	1.00	13.6	46.4	2.11	.80	1.00	1.00	13.2	45.0	2.37	.82	1.00	1.00	12.8	43.6	2.68	.85	1.00	1.00
19°C (67°F)	1.13	2400	13.9	47.3	1.86	.50	.63	.78	13.4	45.8	2.10	.51	.64	.79	13.0	44.3	2.37	.52	.65	.81	12.5	42.7	2.68	.52	.66	.84
	1.41	3000	14.3	48.7	1.87	.54	.68	.88	13.8	47.2	2.11	.54	.69	.90	13.4	45.6	2.38	.55	.71	.93	12.9	43.9	2.69	.56	.73	.95
	1.70	3600	14.6	49.7	1.88	.57	.75	.97	14.1	48.2	2.12	.57	.77	.98	13.6	46.5	2.39	.58	.79	1.00	13.1	44.8	2.69	.59	.82	1.00
22°C (71°F)	1.13	2400	14.8	50.4	1.88	.38	.49	.60	14.3	48.8	2.12	.38	.50	.61	13.8	47.2	2.39	.38	.50	.63	13.3	45.5	2.69	.38	.51	.64
	1.41	3000	15.2	51.8	1.89	.39	.52	.66	14.7	50.2	2.13	.39	.53	.67	14.2	48.4	2.40	.39	.54	.68	13.7	46.7	2.70	.40	.55	.70
	1.70	3600	15.4	52.7	1.90	.40	.56	.72	14.9	51.0	2.13	.40	.57	.74	14.4	49.3	2.40	.41	.58	.76	13.9	47.5	2.70	.41	.59	.79

26 kW HIGH EFFICIENCY COOLING CAPACITY - ALL COMPRESSORS OPERATING

LGA090H2

Entering Wet Bulb Temperature	Total Air Volume		Outdoor Air Temperature Entering Outdoor Coil																							
			27°C (80°F)						35°C (95°F)						43°C (110°F)						52°C (125°F)					
			Total Cooling Capacity		Comp Motor kW Input	Sensible To Total Ratio (S/T) Dry Bulb			Total Cooling Capacity		Comp Motor kW Input	Sensible To Total Ratio (S/T) Dry Bulb			Total Cooling Capacity		Comp Motor kW Input	Sensible To Total Ratio (S/T) Dry Bulb			Total Cooling Capacity		Comp Motor kW Input	Sensible To Total Ratio (S/T) Dry Bulb		
			kW	kBtu/h		24°C 75°F	27°C 80°F	29°C 85°F	kW	kBtu/h		24°C 75°F	27°C 80°F	29°C 85°F	kW	kBtu/h		24°C 75°F	27°C 80°F	29°C 85°F	kW	kBtu/h		24°C 75°F	27°C 80°F	29°C 85°F
17°C (63°F)	1.13	2400	24.1	82.4	4.50	.70	.86	1.00	22.9	78.2	5.40	.71	.89	1.00	21.5	73.5	6.49	.74	.92	1.00	20.0	68.4	7.81	.76	.96	1.00
	1.41	3000	25.1	85.6	4.52	.75	.95	1.00	23.8	81.2	5.42	.78	.98	1.00	22.5	76.7	6.51	.81	.99	1.00	21.1	71.9	7.83	.86	1.00	1.00
	1.70	3600	25.9	88.5	4.54	.82	1.00	1.00	24.7	84.4	5.44	.85	1.00	1.00	23.4	79.8	6.53	.89	1.00	1.00	21.9	74.7	7.84	.93	1.00	1.00
19°C (67°F)	1.13	2400	25.6	87.5	4.53	.54	.68	.82	24.3	82.9	5.44	.55	.69	.85	22.8	77.9	6.53	.56	.71	.88	21.2	72.3	7.84	.58	.74	.93
	1.41	3000	26.4	90.1	4.55	.58	.73	.91	25.0	85.3	5.46	.59	.75	.94	23.4	80.0	6.54	.60	.78	.98	21.7	74.2	7.86	.62	.83	1.00
	1.70	3600	26.9	91.9	4.57	.61	.80	.98	25.5	87.0	5.47	.62	.83	1.00	23.9	81.7	6.56	.64	.86	1.00	22.2	75.9	7.86	.67	.91	1.00
22°C (71°F)	1.13	2400	27.3	93.3	4.57	.40	.53	.65	25.9	88.4	5.47	.41	.54	.67	24.4	83.1	6.56	.41	.55	.69	22.6	77.1	7.88	.42	.57	.72
	1.41	3000	28.1	95.8	4.59	.42	.56	.71	26.6	90.7	5.48	.42	.58	.73	24.9	85.1	6.57	.43	.59	.76	23.1	78.9	7.89	.43	.61	.80
	1.70	3600	28.6	97.5	4.59	.43	.60	.77	27.1	92.3	5.49	.43	.62	.80	25.4	86.5	6.58	.44	.64	.84	23.5	80.2	7.90	.45	.66	.88

26 kW HIGH EFFICIENCY (R-410A) COOLING CAPACITY - ONE COMPRESSOR OPERATING

LGA090H4

Entering Wet Bulb Temperature	Total Air Volume		Outdoor Air Temperature Entering Outdoor Coil																							
			18°C (65°F)						24°C (75°F)						29°C (85°F)						35°C (95°F)					
			Total Cooling Capacity		Comp Motor kW Input	Sensible To Total Ratio (S/T) Dry Bulb			Total Cooling Capacity		Comp Motor kW Input	Sensible To Total Ratio (S/T) Dry Bulb			Total Cooling Capacity		Comp Motor kW Input	Sensible To Total Ratio (S/T) Dry Bulb			Total Cooling Capacity		Comp Motor kW Input	Sensible To Total Ratio (S/T) Dry Bulb		
			kW	kBtu/h		24°C 75°F	27°C 80°F	29°C 85°F	kW	kBtu/h		24°C 75°F	27°C 80°F	29°C 85°F	kW	kBtu/h		24°C 75°F	27°C 80°F	29°C 85°F	kW	kBtu/h		24°C 75°F	27°C 80°F	29°C 85°F
17°C (63°F)	1.13	2400	13.3	45.4	1.83	.67	.82	.97	12.8	43.7	2.10	.68	.84	.98	12.3	42.0	2.40	.69	.86	1.00	11.8	40.1	2.74	.70	.89	1.00
	1.41	3000	13.8	47.2	1.85	.72	.91	1.00	13.3	45.5	2.12	.73	.92	1.00	12.8	43.7	2.42	.75	.95	1.00	12.3	41.8	2.76	.78	.97	1.00
	1.70	3600	14.3	48.7	1.87	.78	.98	1.00	13.8	47.0	2.14	.80	.99	1.00	13.3	45.3	2.42	.82	1.00	1.00	12.7	43.5	2.78	.85	1.00	1.00
19°C (67°F)	1.13	2400	14.2	48.4	1.87	.52	.64	.78	13.7	46.6	2.13	.53	.65	.80	13.1	44.7	2.43	.54	.66	.82	12.5	42.7	2.77	.54	.68	.84
	1.41	3000	14.7	50.0	1.89	.55	.69	.87	14.1	48.2	2.15	.56	.70	.89	13.5	46.2	2.45	.57	.72	.91	12.9	44.1	2.79	.58	.75	.94
	1.70	3600	15.0	51.2	1.91	.58	.75	.94	14.4	49.2	2.17	.59	.77	.96	13.8	47.2	2.47	.60	.80	.98	13.2	45.0	2.80	.61	.82	1.00
22°C (71°F)	1.13	2400	15.2	51.8	1.91	.39	.50	.62	14.6	49.9	2.18	.39	.51	.63	14.0	47.9	2.48	.40	.52	.64	13.4	45.8	2.81	.40	.53	.65
	1.41	3000	15.6	53.4	1.94	.40	.54	.67	15.1	51.4	2.20	.40	.54	.68	14.5	49.4	2.49	.41	.55	.70	13.8	47.1	2.83	.41	.56	.72
	1.70	3600	16.0	54.5	1.95	.41	.57	.72	15.4	52.5	2.22	.42	.58	.74	14.7	50.3	2.51	.42	.59	.76	14.1	48.0	2.84	.43	.60	.79

26 kW HIGH EFFICIENCY (R-410A) COOLING CAPACITY - ALL COMPRESSORS OPERATING

LGA090H4

Entering Wet Bulb Temperature	Total Air Volume		Outdoor Air Temperature Entering Outdoor Coil																							
			27°C (80°F)						35°C (95°F)						43°C (110°F)						52°C (125°F)					
			Total Cooling Capacity		Comp Motor kW Input	Sensible To Total Ratio (S/T) Dry Bulb			Total Cooling Capacity		Comp Motor kW Input	Sensible To Total Ratio (S/T) Dry Bulb			Total Cooling Capacity		Comp Motor kW Input	Sensible To Total Ratio (S/T) Dry Bulb			Total Cooling Capacity		Comp Motor kW Input	Sensible To Total Ratio (S/T) Dry Bulb		
			kW	kBtu/h		24°C 75°F	27°C 80°F	29°C 85°F	kW	kBtu/h		24°C 75°F	27°C 80°F	29°C 85°F	kW	kBtu/h		24°C 75°F	27°C 80°F	29°C 85°F	kW	kBtu/h		24°C 75°F	27°C 80°F	29°C 85°F
17°C (63°F)	1.13	2400	24.4	83.1	4.49	.68	.84	.99	22.8	77.7	5.48	.70	.88	1.00	21.0	71.6	6.70	.73	.93	1.00	19.0	65.0	8.18	.78	.98	1.00
	1.41	3000	25.4	86.5	4.53	.73	.93	1.00	23.7	80.9	5.52	.76	.97	1.00	22.0	75.0	6.73	.81	1.00	1.00	20.2	68.8	8.21	.87	1.00	1.00
	1.70	3600	26.2	89.5	4.57	.80	.99	1.00	24.7	84.2	5.56	.84	1.00	1.00	22.9	78.3	6.77	.89	1.00	1.00	21.0	71.8	8.25	.95	1.00	1.00
19°C (67°F)	1.13	2400	26.0	88.6	4.56	.53	.66	.79	24.3	82.8	5.54	.54	.68	.83	22.3	76.2	6.75	.56	.70	.88	20.2	68.9	8.22	.58	.74	.94
	1.41	3000	26.8	91.4	4.61	.56	.71	.89	25.0	85.3	5.59	.58	.73	.93	23.0	78.6	6.79	.60	.78	.98	20.8	70.9	8.25	.62	.84	1.00
	1.70	3600	27.4	93.6	4.63	.59	.77	.97	25.6	87.3	5.62	.61	.81	.99	23.5	80.3	6.81	.63	.86	1.00	21.3	72.6	8.28	.67	.92	1.00
22°C (71°F)	1.13	2400	27.8	94.9	4.65	.39	.51	.63	26.0	88.7	5.64	.40	.53	.65	24.0	81.9	6.83	.40	.54	.68	21.7	74.0	8.29	.41	.56	.72
	1.41	3000	28.6	97.7	4.69	.40	.55	.69	26.7	91.2	5.67	.41	.56	.71	24.6	83.9	6.87	.42	.58	.75	22.2	75.8	8.33	.43	.61	.81
	1.70	3600	29.2	99.7	4.72	.42	.58	.74	27.2	92.9	5.70	.42	.60	.78	25.1	85.5	6.89	.44	.62	.83	22.6	77.0	8.35	.45	.66	.89

COOLING RATINGS

NOTE - For Temperatures and Capacities not shown in tables, see bulletin - Cooling Unit Rating Table Correction Factor Data in Miscellaneous Engineering Data section.

30 kW STANDARD EFFICIENCY COOLING CAPACITY - ONE COMPRESSOR OPERATING

LGC102S2

Entering Wet Bulb Temperature	Total Air Volume		Outdoor Air Temperature Entering Outdoor Coil																							
			18°C (65°F)						24°C (75°F)						29°C (85°F)						35°C (95°F)					
			Total Cooling Capacity		Comp Motor kW Input	Sensible To Total Ratio (S/T) Dry Bulb			Total Cooling Capacity		Comp Motor kW Input	Sensible To Total Ratio (S/T) Dry Bulb			Total Cooling Capacity		Comp Motor kW Input	Sensible To Total Ratio (S/T) Dry Bulb			Total Cooling Capacity		Comp Motor kW Input	Sensible To Total Ratio (S/T) Dry Bulb		
			kW	kBtuh		24°C 75°F	27°C 80°F	29°C 85°F	kW	kBtuh		24°C 75°F	27°C 80°F	29°C 85°F	kW	kBtuh		24°C 75°F	27°C 80°F	29°C 85°F	kW	kBtuh		24°C 75°F	27°C 80°F	29°C 85°F
17°C (63°F)	1.28	2720	14.2	48.5	2.41	.67	.83	.99	13.7	46.9	2.67	.68	.85	1.00	13.3	45.3	2.96	.69	.87	1.00	12.8	43.6	3.30	.70	.89	1.00
	1.60	3400	14.7	50.3	2.44	.72	.93	1.00	14.3	48.7	2.70	.74	.95	1.00	13.8	47.0	3.00	.75	.97	1.00	13.3	45.3	3.34	.78	.99	1.00
	1.92	4080	15.2	51.9	2.47	.79	.99	1.00	14.7	50.3	2.74	.81	1.00	1.00	14.3	48.7	3.04	.83	1.00	1.00	13.8	47.0	3.38	.86	1.00	1.00
19°C (67°F)	1.28	2720	15.1	51.4	2.46	.52	.64	.79	14.6	49.7	2.73	.53	.65	.81	14.0	47.9	3.02	.53	.67	.83	13.5	46.1	3.36	.54	.68	.85
	1.60	3400	15.5	52.8	2.49	.55	.70	.89	15.0	51.1	2.75	.56	.71	.91	14.4	49.2	3.05	.57	.73	.94	13.9	47.3	3.40	.57	.75	.96
	1.92	4080	15.8	53.9	2.52	.58	.76	.97	15.3	52.1	2.78	.59	.78	.98	14.7	50.2	3.08	.60	.81	1.00	14.1	48.2	3.42	.61	.83	1.00
22°C (71°F)	1.28	2720	16.0	54.6	2.53	.39	.50	.62	15.5	52.8	2.79	.39	.51	.63	14.9	51.0	3.09	.39	.52	.64	14.4	49.0	3.43	.39	.53	.66
	1.60	3400	16.4	56.0	2.56	.40	.54	.68	15.9	54.2	2.82	.40	.55	.69	15.3	52.2	3.12	.40	.56	.70	14.7	50.1	3.46	.41	.57	.73
	1.92	4080	16.7	57.0	2.58	.41	.57	.74	16.1	55.1	2.84	.41	.58	.76	15.6	53.1	3.14	.42	.59	.78	14.9	50.9	3.48	.42	.60	.81

30 kW STANDARD EFFICIENCY COOLING CAPACITY - ALL COMPRESSORS OPERATING

LGC102S2

Entering Wet Bulb Temperature	Total Air Volume		Outdoor Air Temperature Entering Outdoor Coil																							
			27°C (80°F)						35°C (95°F)						43°C (110°F)						52°C (125°F)					
			Total Cooling Capacity		Comp Motor kW Input	Sensible To Total Ratio (S/T) Dry Bulb			Total Cooling Capacity		Comp Motor kW Input	Sensible To Total Ratio (S/T) Dry Bulb			Total Cooling Capacity		Comp Motor kW Input	Sensible To Total Ratio (S/T) Dry Bulb			Total Cooling Capacity		Comp Motor kW Input	Sensible To Total Ratio (S/T) Dry Bulb		
			kW	kBtuh		24°C 75°F	27°C 80°F	29°C 85°F	kW	kBtuh		24°C 75°F	27°C 80°F	29°C 85°F	kW	kBtuh		24°C 75°F	27°C 80°F	29°C 85°F	kW	kBtuh		24°C 75°F	27°C 80°F	29°C 85°F
17°C (63°F)	1.28	2720	26.6	90.8	5.88	.69	.85	.99	25.1	85.8	6.91	.71	.89	1.00	23.5	80.2	8.17	.73	.93	1.00	21.7	74.0	9.70	.77	.97	1.00
	1.60	3400	27.6	94.1	5.95	.75	.95	1.00	26.1	89.0	6.99	.77	.98	1.00	24.5	83.5	8.26	.81	1.00	1.00	22.7	77.6	9.80	.86	1.00	1.00
	1.92	4080	28.5	97.3	6.02	.81	1.00	1.00	27.1	92.3	7.07	.85	1.00	1.00	25.4	86.7	8.35	.89	1.00	1.00	23.6	80.6	9.88	.94	1.00	1.00
19°C (67°F)	1.28	2720	28.2	96.1	6.00	.54	.67	.81	26.6	90.7	7.03	.55	.69	.85	24.8	84.6	8.30	.56	.71	.89	22.8	77.8	9.83	.58	.74	.94
	1.60	3400	29.0	98.9	6.06	.57	.73	.91	27.3	93.1	7.11	.58	.75	.95	25.4	86.8	8.36	.60	.79	.98	23.4	79.8	9.89	.63	.84	1.00
	1.92	4080	29.6	100.9	6.11	.60	.79	.98	27.8	94.9	7.16	.62	.83	1.00	25.9	88.5	8.41	.64	.87	1.00	23.9	81.4	9.93	.67	.92	1.00
22°C (71°F)	1.28	2720	30.0	102.2	6.14	.40	.52	.65	28.3	96.5	7.18	.40	.53	.67	26.4	90.0	8.45	.41	.55	.69	24.3	82.8	9.98	.41	.57	.72
	1.60	3400	30.7	104.8	6.21	.41	.56	.71	28.9	98.7	7.24	.42	.57	.73	27.0	92.0	8.51	.42	.59	.76	24.7	84.4	10.04	.43	.62	.81
	1.92	4080	31.2	106.6	6.25	.42	.60	.77	29.4	100.3	7.29	.43	.61	.80	27.4	93.4	8.55	.44	.64	.85	25.1	85.6	10.08	.45	.67	.90

30 kW HIGH EFFICIENCY COOLING CAPACITY - ONE COMPRESSOR OPERATING

LGA102H2

Entering Wet Bulb Temperature	Total Air Volume		Outdoor Air Temperature Entering Outdoor Coil																							
			18°C (65°F)						24°C (75°F)						29°C (85°F)						35°C (95°F)					
			Total Cooling Capacity		Comp Motor kW Input	Sensible To Total Ratio (S/T) Dry Bulb			Total Cooling Capacity		Comp Motor kW Input	Sensible To Total Ratio (S/T) Dry Bulb			Total Cooling Capacity		Comp Motor kW Input	Sensible To Total Ratio (S/T) Dry Bulb			Total Cooling Capacity		Comp Motor kW Input	Sensible To Total Ratio (S/T) Dry Bulb		
			kW	kBtuh		24°C 75°F	27°C 80°F	29°C 85°F	kW	kBtuh		24°C 75°F	27°C 80°F	29°C 85°F	kW	kBtuh		24°C 75°F	27°C 80°F	29°C 85°F	kW	kBtuh		24°C 75°F	27°C 80°F	29°C 85°F
17°C (63°F)	1.28	2720	14.2	48.6	2.13	.69	.84	.99	13.9	47.3	2.40	.69	.86	1.00	13.4	45.8	2.71	.71	.88	1.00	13.0	44.2	3.05	.72	.90	1.00
	1.60	3400	14.8	50.5	2.14	.74	.93	1.00	14.4	49.1	2.41	.75	.95	1.00	14.0	47.6	2.72	.77	.96	1.00	13.5	45.9	3.07	.79	.98	1.00
	1.92	4080	15.3	52.2	2.15	.81	.99	1.00	14.9	50.8	2.42	.82	1.00	1.00	14.4	49.3	2.73	.84	1.00	1.00	14.0	47.7	3.08	.86	1.00	1.00
19°C (67°F)	1.28	2720	15.2	51.7	2.15	.53	.66	.80	14.7	50.2	2.42	.54	.67	.82	14.2	48.6	2.73	.55	.68	.84	13.7	46.8	3.08	.55	.69	.86
	1.60	3400	15.6	53.3	2.16	.57	.72	.89	15.2	51.8	2.43	.57	.73	.91	14.7	50.0	2.74	.58	.74	.93	14.1	48.2	3.09	.59	.76	.95
	1.92	4080	16.0	54.5	2.17	.60	.78	.97	15.5	52.9	2.44	.61	.79	.98	15.0	51.1	2.75	.61	.81	.99	14.4	49.1	3.10	.63	.84	1.00
22°C (71°F)	1.28	2720	16.2	55.3	2.17	.40	.52	.64	15.7	53.7	2.44	.40	.52	.65	15.2	51.9	2.75	.40	.53	.66	14.7	50.0	3.09	.40	.54	.67
	1.60	3400	16.6	56.8	2.18	.41	.55	.69	16.1	55.1	2.45	.41	.56	.71	15.6	53.3	2.76	.42	.57	.72	15.0	51.2	3.11	.42	.58	.74
	1.92	4080	17.0	57.9	2.19	.42	.59	.75	16.5	56.2	2.46	.43	.59	.77	15.9	54.2	2.77	.43	.61	.79	15.3	52.1	3.11	.43	.62	.81

30 kW HIGH EFFICIENCY COOLING CAPACITY - ALL COMPRESSORS OPERATING

LGA102H2

Entering Wet Bulb Temperature	Total Air Volume		Outdoor Air Temperature Entering Outdoor Coil																							
			27°C (80°F)						35°C (95°F)						43°C (110°F)						52°C (125°F)					
			Total Cooling Capacity		Comp Motor kW Input	Sensible To Total Ratio (S/T) Dry Bulb			Total Cooling Capacity		Comp Motor kW Input	Sensible To Total Ratio (S/T) Dry Bulb			Total Cooling Capacity		Comp Motor kW Input	Sensible To Total Ratio (S/T) Dry Bulb			Total Cooling Capacity		Comp Motor kW Input	Sensible To Total Ratio (S/T) Dry Bulb		
			kW	kBtuh		24°C 75°F	27°C 80°F	29°C 85°F	kW	kBtuh		24°C 75°F	27°C 80°F	29°C 85°F	kW	kBtuh		24°C 75°F	27°C 80°F	29°C 85°F	kW	kBtuh		24°C 75°F	27°C 80°F	29°C 85°F
17°C (63°F)	1.28	2720	27.3	93.1	5.25	.70	.86	.99	25.9	88.4	6.28	.72	.89	1.00	24.3	83.0	7.53	.74	.92	1.00	22.5	76.9	9.03	.77	.97	1.00
	1.60	3400	28.4	96.9	5.27	.76	.94	1.00	26.9	91.8	6.32	.78	.97	1.00	25.3	86.4	7.56	.81	1.00	1.00	23.7	80.8	9.06	.86	1.00	1.00
	1.92	4080	29.3	100.1	5.29	.82	1.00	1.00	27.9	95.3	6.34	.85	1.00	1.00	26.3	89.9	7.60	.89	1.00	1.00	24.6	84.0	9.09	.93	1.00	1.00
19°C (67°F)	1.28	2720	29.0	99.0	5.29	.55	.68	.82	27.5	93.7	6.34	.56	.70	.85	25.7	87.8	7.58	.57	.72	.88	23.8	81.2	9.08	.59	.75	.93
	1.60	3400	29.9	102.0	5.31	.58	.73	.91	28.3	96.5	6.36	.59	.76	.94	26.4	90.2	7.62	.61	.79	.97	24.4	83.4	9.10	.63	.83	1.00
	1.92	4080	30.5	104.2	5.33	.61	.80	.98	28.8	98.4	6.38	.63	.83	1.00	27.0	92.1	7.63	.65	.86	1.00	25.0	85.2	9.12	.67	.91	1.00
22°C (71°F)	1.28	2720	31.0	105.7	5.34	.41	.53	.66	29.3	100.1	6.38	.41	.54	.67	27.5	93.7	7.63	.41	.55	.69	25.4	86.6	9.14	.42	.57	.72
	1.60	3400	31.8	108.6	5.36	.42	.57	.71	30.1	102.6	6.41	.42	.58	.73	28.1	95.9	7.65	.43	.60	.76	26.0	88.6	9.15	.44	.62	.81
	1.92	4080	32.4	110.6	5.38	.43	.60	.77	30.6	104.4	6.42	.44	.62	.80	28.6	97.5	7.67	.45	.64	.84	26.4	90.0	9.17	.46	.67	.88

COOLING RATINGS

NOTE - For Temperatures and Capacities not shown in tables, see bulletin - Cooling Unit Rating Table Correction Factor Data in Miscellaneous Engineering Data section.

30 kW HIGH EFFICIENCY (R-410A) COOLING CAPACITY - ONE COMPRESSOR OPERATING

LGA102H4

Entering Wet Bulb Temperature	Total Air Volume		Outdoor Air Temperature Entering Outdoor Coil																							
			18°C (65°F)						24°C (75°F)						29°C (85°F)						35°C (95°F)					
			Total Cooling Capacity		Comp Motor kW Input	Sensible To Total Ratio (S/T) Dry Bulb			Total Cooling Capacity		Comp Motor kW Input	Sensible To Total Ratio (S/T) Dry Bulb			Total Cooling Capacity		Comp Motor kW Input	Sensible To Total Ratio (S/T) Dry Bulb			Total Cooling Capacity		Comp Motor kW Input	Sensible To Total Ratio (S/T) Dry Bulb		
			kW	kBtuh		24°C 75°F	27°C 80°F	29°C 85°F	kW	kBtuh		24°C 75°F	27°C 80°F	29°C 85°F	kW	kBtuh		24°C 75°F	27°C 80°F	29°C 85°F	kW	kBtuh		24°C 75°F	27°C 80°F	29°C 85°F
17°C (63°F)	1.28	2720	14.5	49.5	2.02	.58	.77	.98	14.0	47.7	2.30	.58	.80	1.00	13.5	45.9	2.61	.60	.83	1.00	12.9	43.9	2.97	.61	.87	1.00
	1.60	3400	15.1	51.4	2.02	.63	.90	1.00	14.5	49.6	2.31	.65	.93	1.00	14.0	47.7	2.62	.68	.96	1.00	13.4	45.7	2.98	.71	.99	1.00
	1.92	4080	15.6	53.1	2.03	.72	.99	1.00	15.0	51.3	2.32	.75	1.00	1.00	14.5	49.5	2.63	.78	1.00	1.00	13.9	47.5	2.99	.82	1.00	1.00
19°C (67°F)	1.28	2720	15.4	52.6	2.03	.45	.56	.72	14.8	50.6	2.32	.46	.57	.74	14.2	48.6	2.63	.46	.58	.78	13.6	46.4	2.99	.47	.59	.81
	1.60	3400	15.9	54.1	2.04	.47	.60	.84	15.3	52.1	2.32	.48	.62	.88	14.7	50.0	2.64	.49	.64	.91	14.0	47.7	3.00	.50	.67	.95
	1.92	4080	16.2	55.3	2.05	.50	.68	.95	15.6	53.2	2.33	.51	.71	.98	14.9	51.0	2.65	.52	.74	1.00	14.3	48.7	3.00	.53	.78	1.00
22°C (71°F)	1.28	2720	16.4	56.1	2.05	.33	.44	.54	15.8	54.0	2.34	.34	.44	.55	15.2	51.9	2.65	.34	.45	.56	14.5	49.6	3.01	.34	.46	.57
	1.60	3400	16.9	57.6	2.06	.34	.46	.59	16.2	55.4	2.35	.35	.47	.60	15.6	53.2	2.66	.35	.48	.61	14.9	50.8	3.02	.35	.49	.64
	1.92	4080	17.2	58.7	2.07	.35	.49	.65	16.5	56.4	2.36	.36	.50	.67	15.9	54.1	2.67	.36	.51	.71	15.1	51.6	3.02	.37	.52	.75

30 kW HIGH EFFICIENCY (R-410A) COOLING CAPACITY - ALL COMPRESSORS OPERATING

LGA102H4

Entering Wet Bulb Temperature	Total Air Volume		Outdoor Air Temperature Entering Outdoor Coil																							
			27°C (80°F)						35°C (95°F)						43°C (110°F)						52°C (125°F)					
			Total Cooling Capacity		Comp Motor kW Input	Sensible To Total Ratio (S/T) Dry Bulb			Total Cooling Capacity		Comp Motor kW Input	Sensible To Total Ratio (S/T) Dry Bulb			Total Cooling Capacity		Comp Motor kW Input	Sensible To Total Ratio (S/T) Dry Bulb			Total Cooling Capacity		Comp Motor kW Input	Sensible To Total Ratio (S/T) Dry Bulb		
			kW	kBtuh		24°C 75°F	27°C 80°F	29°C 85°F	kW	kBtuh		24°C 75°F	27°C 80°F	29°C 85°F	kW	kBtuh		24°C 75°F	27°C 80°F	29°C 85°F	kW	kBtuh		24°C 75°F	27°C 80°F	29°C 85°F
17°C (63°F)	1.28	2720	27.0	92.2	5.12	.68	.85	1.00	25.3	86.4	6.19	.70	.89	1.00	23.4	79.9	7.55	.73	.94	1.00	21.4	73.1	9.25	.78	.99	1.00
	1.60	3400	28.0	95.7	5.14	.74	.95	1.00	26.3	89.8	6.22	.77	.98	1.00	24.5	83.6	7.56	.82	1.00	1.00	22.6	77.1	9.27	.88	1.00	1.00
	1.92	4080	29.0	99.0	5.16	.81	1.00	1.00	27.3	93.3	6.24	.85	1.00	1.00	25.5	87.0	7.59	.90	1.00	1.00	23.5	80.1	9.29	.96	1.00	1.00
19°C (67°F)	1.28	2720	28.6	97.7	5.16	.53	.66	.81	26.8	91.4	6.23	.54	.68	.85	24.8	84.5	7.58	.56	.71	.90	22.5	76.9	9.27	.58	.74	.96
	1.60	3400	29.5	100.7	5.17	.56	.72	.91	27.5	94.0	6.26	.58	.74	.95	25.4	86.8	7.59	.60	.79	.99	23.2	79.1	9.29	.63	.85	1.00
	1.92	4080	30.1	102.7	5.19	.60	.78	.98	28.1	96.0	6.28	.61	.82	1.00	26.0	88.6	7.61	.64	.87	1.00	23.7	80.9	9.31	.67	.93	1.00
22°C (71°F)	1.28	2720	30.5	104.2	5.20	.39	.52	.64	28.6	97.6	6.28	.40	.53	.66	26.5	90.3	7.63	.40	.55	.69	24.1	82.3	9.33	.41	.57	.72
	1.60	3400	31.4	107.0	5.22	.40	.55	.70	29.3	100.1	6.30	.41	.57	.72	27.1	92.4	7.65	.42	.59	.76	24.6	84.1	9.35	.43	.62	.82
	1.92	4080	31.9	109.0	5.23	.42	.59	.75	29.8	101.7	6.32	.43	.61	.80	27.5	93.8	7.66	.44	.63	.85	25.1	85.5	9.36	.45	.66	.91

35 kW STANDARD EFFICIENCY COOLING CAPACITY - ONE COMPRESSOR OPERATING

LGC120S2

Entering Wet Bulb Temperature	Total Air Volume		Outdoor Air Temperature Entering Outdoor Coil																							
			18°C (65°F)						24°C (75°F)						29°C (85°F)						35°C (95°F)					
			Total Cooling Capacity		Comp Motor kW Input	Sensible To Total Ratio (S/T) Dry Bulb			Total Cooling Capacity		Comp Motor kW Input	Sensible To Total Ratio (S/T) Dry Bulb			Total Cooling Capacity		Comp Motor kW Input	Sensible To Total Ratio (S/T) Dry Bulb			Total Cooling Capacity		Comp Motor kW Input	Sensible To Total Ratio (S/T) Dry Bulb		
			kW	kBtuh		24°C 75°F	27°C 80°F	29°C 85°F	kW	kBtuh		24°C 75°F	27°C 80°F	29°C 85°F	kW	kBtuh		24°C 75°F	27°C 80°F	29°C 85°F	kW	kBtuh		24°C 75°F	27°C 80°F	29°C 85°F
17°C (63°F)	1.51	3200	17.2	58.8	3.00	.72	.87	1.00	16.9	57.5	3.28	.73	.88	1.00	16.4	55.8	3.61	.74	.90	1.00	15.8	53.8	3.98	.75	.92	1.00
	1.89	4000	17.9	61.0	3.05	.78	.95	1.00	17.5	59.6	3.32	.79	.96	1.00	17.0	57.9	3.64	.80	.98	1.00	16.4	56.0	4.02	.82	.99	1.00
	2.26	4800	18.5	63.0	3.08	.84	1.00	1.00	18.1	61.7	3.36	.86	1.00	1.00	17.6	60.1	3.68	.87	1.00	1.00	17.1	58.2	4.07	.89	1.00	1.00
19°C (67°F)	1.51	3200	18.2	62.1	3.07	.56	.70	.84	17.8	60.7	3.34	.57	.71	.85	17.3	59.0	3.66	.57	.72	.86	16.7	56.9	4.04	.58	.73	.88
	1.89	4000	18.7	63.9	3.10	.60	.76	.92	18.3	62.4	3.38	.60	.77	.94	17.8	60.6	3.70	.61	.78	.95	17.1	58.5	4.07	.62	.80	.97
	2.26	4800	19.1	65.1	3.13	.63	.82	.99	18.7	63.7	3.40	.64	.84	.99	18.1	61.8	3.72	.65	.85	1.00	17.5	59.6	4.10	.66	.87	1.00
22°C (71°F)	1.51	3200	19.3	65.9	3.14	.42	.55	.68	18.9	64.5	3.41	.42	.55	.68	18.3	62.6	3.73	.42	.56	.69	17.7	60.5	4.12	.42	.56	.71
	1.89	4000	19.8	67.5	3.18	.43	.59	.74	19.3	66.0	3.45	.43	.59	.75	18.8	64.2	3.77	.44	.60	.76	18.1	61.9	4.14	.44	.61	.78
	2.26	4800	20.1	68.6	3.20	.45	.63	.80	19.7	67.1	3.46	.45	.63	.82	19.1	65.2	3.79	.45	.64	.83	18.4	62.9	4.16	.46	.65	.85

35 kW STANDARD EFFICIENCY COOLING CAPACITY - ALL COMPRESSORS OPERATING

LGC120S2

Entering Wet Bulb Temperature	Total Air Volume		Outdoor Air Temperature Entering Outdoor Coil																							
			27°C (80°F)						35°C (95°F)						43°C (110°F)						52°C (125°F)					
			Total Cooling Capacity		Comp Motor kW Input	Sensible To Total Ratio (S/T) Dry Bulb			Total Cooling Capacity		Comp Motor kW Input	Sensible To Total Ratio (S/T) Dry Bulb			Total Cooling Capacity		Comp Motor kW Input	Sensible To Total Ratio (S/T) Dry Bulb			Total Cooling Capacity		Comp Motor kW Input	Sensible To Total Ratio (S/T) Dry Bulb		
			kW	kBtuh		24°C 75°F	27°C 80°F	29°C 85°F	kW	kBtuh		24°C 75°F	27°C 80°F	29°C 85°F	kW	kBtuh		24°C 75°F	27°C 80°F	29°C 85°F	kW	kBtuh		24°C 75°F	27°C 80°F	29°C 85°F
17°C (63°F)	1.51	3200	32.7	111.6	7.02	.74	.88	1.00	31.0	105.8	8.14	.75	.91	1.00	29.2	99.5	9.51	.77	.94	1.00	27.3	93.3	11.17	.80	.97	1.00
	1.89	4000	33.9	115.8	7.10	.80	.96	1.00	32.3	110.1	8.22	.82	.98	1.00	30.5	103.9	9.60	.85	1.00	1.00	28.7	97.9	11.29	.88	1.00	1.00
	2.26	4800	35.1	119.7	7.17	.86	1.00	1.00	33.5	114.3	8.31	.88	1.00	1.00	31.7	108.2	9.71	.91	1.00	1.00	29.8	101.7	11.39	.95	1.00	1.00
19°C (67°F)	1.51	3200	34.6	118.0	7.15	.57	.71	.85	32.8	112.0	8.26	.58	.73	.87	30.8	105.1	9.65	.60	.75	.91	28.8	98.2	11.32	.61	.78	.94
	1.89	4000	35.6	121.4	7.21	.61	.78	.93	33.8	115.2	8.33	.62	.80	.96	31.7	108.1	9.72	.64	.83	.99	29.6	100.9	11.40	.66	.86	1.00
	2.26	4800	36.3	123.8	7.27	.65	.84	.99	34.4	117.4	8.38	.66	.86	1.00	32.3	110.3	9.78	.68	.90	1.00	30.2	103.1	11.46	.71	.93	1.00
22°C (71°F)	1.51	3200	36.7	125.3	7.29	.42	.56	.69	34.9	119.1	8.42	.43	.57	.71	32.8	111.9	9.82	.43	.58	.73	30.6	104.5	11.50	.44	.60	.76
	1.89	4000	37.6	128.4	7.36	.44	.60	.76	35.8	122.0	8.48	.44	.61	.78	33.6	114.6	9.87	.45	.63	.80	31.3	106.7	11.57	.46	.65	.84
	2.26	4800	38.3	130.6	7.40	.45	.64	.82	36.3	124.0	8.52	.46	.66	.84	34.1	116.4	9.91	.47	.68	.88	31.7	108.3	11.61	.48	.70	.91

COOLING RATINGS

NOTE - For Temperatures and Capacities not shown in tables, see bulletin - Cooling Unit Rating Table Correction Factor Data in Miscellaneous Engineering Data section.

35 kW HIGH EFFICIENCY COOLING CAPACITY - ONE COMPRESSOR OPERATING

LGA120H2

Entering Wet Bulb Temperature	Total Air Volume		Outdoor Air Temperature Entering Outdoor Coil																							
			18°C (65°F)						24°C (75°F)						29°C (85°F)						35°C (95°F)					
			Total Cooling Capacity		Comp Motor kW Input	Sensible To Total Ratio (S/T) Dry Bulb			Total Cooling Capacity		Comp Motor kW Input	Sensible To Total Ratio (S/T) Dry Bulb			Total Cooling Capacity		Comp Motor kW Input	Sensible To Total Ratio (S/T) Dry Bulb			Total Cooling Capacity		Comp Motor kW Input	Sensible To Total Ratio (S/T) Dry Bulb		
			kW	kBtu/h		24°C 75°F	27°C 80°F	29°C 85°F	kW	kBtu/h		24°C 75°F	27°C 80°F	29°C 85°F	kW	kBtu/h		24°C 75°F	27°C 80°F	29°C 85°F	kW	kBtu/h		24°C 75°F	27°C 80°F	29°C 85°F
17°C (63°F)	1.51	3200	17.6	60.0	2.70	.67	.83	.99	17.1	58.2	3.03	.67	.85	1.00	16.5	56.3	3.42	.69	.87	1.00	15.9	54.3	3.86	.70	.89	1.00
	1.89	4000	18.3	62.3	2.73	.72	.93	1.00	17.7	60.4	3.05	.74	.95	1.00	17.1	58.5	3.44	.76	.97	1.00	16.6	56.5	3.88	.78	.99	1.00
	2.26	4800	18.9	64.4	2.75	.80	1.00	1.00	18.3	62.6	3.07	.81	1.00	1.00	17.8	60.7	3.46	.83	1.00	1.00	17.2	58.8	3.91	.86	1.00	1.00
19°C (67°F)	1.51	3200	18.6	63.6	2.74	.52	.64	.79	18.1	61.6	3.07	.52	.65	.80	17.5	59.6	3.45	.53	.66	.83	16.8	57.4	3.90	.54	.67	.85
	1.89	4000	19.2	65.5	2.76	.55	.70	.89	18.6	63.4	3.09	.56	.71	.91	18.0	61.3	3.47	.57	.73	.93	17.3	59.0	3.92	.57	.75	.96
	2.26	4800	19.6	66.9	2.77	.58	.77	.97	19.0	64.8	3.10	.59	.79	.99	18.3	62.5	3.49	.60	.81	1.00	17.6	60.2	3.93	.61	.83	1.00
22°C (71°F)	1.51	3200	19.8	67.7	2.78	.39	.50	.62	19.2	65.6	3.11	.39	.51	.63	18.6	63.4	3.50	.39	.52	.64	17.9	61.1	3.95	.39	.52	.65
	1.89	4000	20.4	69.5	2.80	.40	.54	.68	19.7	67.3	3.13	.40	.55	.69	19.0	65.0	3.51	.40	.56	.70	18.3	62.5	3.96	.41	.56	.72
	2.26	4800	20.7	70.8	2.81	.41	.57	.74	20.1	68.5	3.14	.42	.58	.76	19.4	66.1	3.53	.42	.60	.78	18.6	63.6	3.98	.42	.61	.81

35 kW HIGH EFFICIENCY COOLING CAPACITY - ALL COMPRESSORS OPERATING

LGA120H2

Entering Wet Bulb Temperature	Total Air Volume		Outdoor Air Temperature Entering Outdoor Coil																							
			27°C (80°F)						35°C (95°F)						43°C (110°F)						52°C (125°F)					
			Total Cooling Capacity		Comp Motor kW Input	Sensible To Total Ratio (S/T) Dry Bulb			Total Cooling Capacity		Comp Motor kW Input	Sensible To Total Ratio (S/T) Dry Bulb			Total Cooling Capacity		Comp Motor kW Input	Sensible To Total Ratio (S/T) Dry Bulb			Total Cooling Capacity		Comp Motor kW Input	Sensible To Total Ratio (S/T) Dry Bulb		
			kW	kBtu/h		24°C 75°F	27°C 80°F	29°C 85°F	kW	kBtu/h		24°C 75°F	27°C 80°F	29°C 85°F	kW	kBtu/h		24°C 75°F	27°C 80°F	29°C 85°F	kW	kBtu/h		24°C 75°F	27°C 80°F	29°C 85°F
17°C (63°F)	1.51	3200	33.0	112.5	6.48	.69	.85	.99	31.3	106.9	7.78	.77	.88	1.00	29.5	100.6	9.37	.73	.92	1.00	27.5	93.8	11.29	.76	.96	1.00
	1.89	4000	34.3	117.0	6.53	.75	.95	1.00	32.6	111.1	7.83	.77	.97	1.00	30.7	104.9	9.43	.81	.99	1.00	28.8	98.4	11.35	.85	1.00	1.00
	2.26	4800	35.5	121.0	6.57	.82	1.00	1.00	33.8	115.3	7.88	.85	1.00	1.00	32.0	109.2	9.48	.89	1.00	1.00	30.0	102.3	11.40	.93	1.00	1.00
19°C (67°F)	1.51	3200	34.9	119.2	6.55	.54	.67	.81	33.1	113.1	7.86	.55	.69	.84	31.2	106.3	9.46	.56	.71	.88	29.0	98.8	11.37	.58	.73	.92
	1.89	4000	36.0	122.9	6.60	.57	.73	.91	34.1	116.3	7.91	.59	.75	.94	32.0	109.2	9.51	.60	.78	.97	29.7	101.5	11.42	.62	.82	1.00
	2.26	4800	36.8	125.5	6.63	.61	.80	.98	34.8	118.7	7.94	.62	.83	1.00	32.7	111.5	9.55	.64	.86	1.00	30.4	103.7	11.46	.67	.91	1.00
22°C (71°F)	1.51	3200	37.2	126.9	6.64	.40	.52	.65	35.3	120.4	7.96	.40	.53	.66	33.1	113.1	9.57	.41	.55	.69	30.8	105.1	11.48	.41	.56	.71
	1.89	4000	38.2	130.3	6.68	.41	.56	.71	36.1	123.3	8.00	.42	.57	.73	33.9	115.8	9.61	.42	.59	.76	31.5	107.5	11.53	.43	.61	.80
	2.26	4800	38.9	132.6	6.72	.43	.60	.77	36.8	125.5	8.04	.43	.62	.80	34.5	117.6	9.64	.44	.64	.84	32.0	109.2	11.56	.45	.66	.89

35 kW HIGH EFFICIENCY (R-410A) COOLING CAPACITY - ONE COMPRESSOR OPERATING

LGA120H4

Entering Wet Bulb Temperature	Total Air Volume		Outdoor Air Temperature Entering Outdoor Coil																							
			18°C (65°F)						24°C (75°F)						29°C (85°F)						35°C (95°F)					
			Total Cooling Capacity		Comp Motor kW Input	Sensible To Total Ratio (S/T) Dry Bulb			Total Cooling Capacity		Comp Motor kW Input	Sensible To Total Ratio (S/T) Dry Bulb			Total Cooling Capacity		Comp Motor kW Input	Sensible To Total Ratio (S/T) Dry Bulb			Total Cooling Capacity		Comp Motor kW Input	Sensible To Total Ratio (S/T) Dry Bulb		
			kW	kBtu/h		24°C 75°F	27°C 80°F	29°C 85°F	kW	kBtu/h		24°C 75°F	27°C 80°F	29°C 85°F	kW	kBtu/h		24°C 75°F	27°C 80°F	29°C 85°F	kW	kBtu/h		24°C 75°F	27°C 80°F	29°C 85°F
17°C (63°F)	1.51	3200	17.3	58.9	2.50	.66	.84	1.00	16.6	56.7	2.85	.67	.86	1.00	15.9	54.4	3.23	.69	.89	1.00	15.2	51.9	3.68	.70	.92	1.00
	1.89	4000	17.9	61.2	2.52	.72	.94	1.00	17.3	58.9	2.87	.74	.97	1.00	16.6	56.6	3.26	.77	.99	1.00	15.9	54.2	3.70	.79	1.00	1.00
	2.26	4800	18.6	63.3	2.54	.80	1.00	1.00	17.9	61.1	2.89	.82	1.00	1.00	17.2	58.8	3.28	.85	1.00	1.00	16.5	56.4	3.73	.89	1.00	1.00
19°C (67°F)	1.51	3200	18.3	62.4	2.54	.52	.64	.79	17.6	60.0	2.88	.52	.65	.81	16.8	57.4	3.27	.53	.67	.84	16.0	54.7	3.72	.54	.68	.88
	1.89	4000	18.8	64.2	2.56	.55	.70	.90	18.1	61.7	2.90	.56	.71	.93	17.3	59.0	3.29	.57	.74	.96	16.5	56.2	3.73	.58	.77	.99
	2.26	4800	19.2	65.6	2.57	.58	.77	.99	18.5	63.0	2.92	.59	.80	1.00	17.6	60.2	3.31	.61	.83	1.00	16.8	57.4	3.75	.62	.86	1.00
22°C (71°F)	1.51	3200	19.5	66.4	2.58	.38	.50	.62	18.7	63.8	2.92	.38	.51	.63	17.9	61.1	3.31	.39	.52	.64	17.1	58.2	3.76	.39	.53	.66
	1.89	4000	20.0	68.1	2.60	.39	.54	.68	19.2	65.4	2.95	.40	.55	.69	18.3	62.6	3.33	.40	.56	.71	17.4	59.5	3.78	.41	.57	.74
	2.26	4800	20.3	69.3	2.61	.41	.57	.74	19.5	66.5	2.96	.41	.58	.77	18.6	63.6	3.35	.42	.60	.80	17.7	60.4	3.79	.42	.61	.84

35 kW HIGH EFFICIENCY (R-410A) COOLING CAPACITY - ALL COMPRESSORS OPERATING

LGA120H4

Entering Wet Bulb Temperature	Total Air Volume		Outdoor Air Temperature Entering Outdoor Coil																							
			27°C (80°F)						35°C (95°F)						43°C (110°F)						52°C (125°F)					
			Total Cooling Capacity		Comp Motor kW Input	Sensible To Total Ratio (S/T) Dry Bulb			Total Cooling Capacity		Comp Motor kW Input	Sensible To Total Ratio (S/T) Dry Bulb			Total Cooling Capacity		Comp Motor kW Input	Sensible To Total Ratio (S/T) Dry Bulb			Total Cooling Capacity		Comp Motor kW Input	Sensible To Total Ratio (S/T) Dry Bulb		
			kW	kBtu/h		24°C 75°F	27°C 80°F	29°C 85°F	kW	kBtu/h		24°C 75°F	27°C 80°F	29°C 85°F	kW	kBtu/h		24°C 75°F	27°C 80°F	29°C 85°F	kW	kBtu/h		24°C 75°F	27°C 80°F	29°C 85°F
17°C (63°F)	1.51	3200	33.1	112.8	6.22	.69	.85	.99	30.9	105.3	7.54	.71	.89	1.00	28.4	96.9	9.20	.74	.94	1.00	25.8	87.9	11.27	.79	.98	1.00
	1.89	4000	34.4	117.3	6.27	.74	.95	1.00	32.1	109.7	7.60	.78	.98	1.00	29.7	101.4	9.26	.83	1.00	1.00	27.1	92.4	11.33	.90	1.00	1.00
	2.26	4800	35.6	121.5	6.32	.82	.99	1.00	33.4	113.9	7.65	.86	1.00	1.00	30.9	105.5	9.31	.92	1.00	1.00	28.1	95.9	11.39	.97	1.00	1.00
19°C (67°F)	1.51	3200	35.0	119.5	6.31	.54	.67	.81	32.6	111.3	7.63	.55	.69	.85	29.9	102.1	9.28	.57	.72	.90	26.9	91.7	11.34	.59	.76	.97
	1.89	4000	36.0	123.0	6.35	.57	.73	.91	33.5	114.4	7.68	.59	.75	.95	30.7	104.9	9.32	.61	.80	.98	27.6	94.3	11.38	.64	.87	1.00
	2.26	4800	36.8	125.6	6.38	.60	.79	.98	34.2	116.8	7.71	.63	.84	.99	31.4	107.1	9.36	.65	.89	1.00	28.3	96.5	11.42	.69	.95	1.00
22°C (71°F)	1.51	3200	37.3	127.2	6.40	.40	.52	.64	34.7	118.3	7.74	.40	.54	.67	31.8	108.6	9.39	.41	.55	.70	28.6	97.6	11.44	.42	.58	.74
	1.89	4000	38.3	130.6	6.44	.41	.56	.70	35.5	121.3	7.78	.42	.58	.73	32.5	111.0	9.42	.43	.60	.78	29.2	99.6	11.48	.44	.63	.84
	2.26	4800	38.9	132.9	6.49	.42	.60	.77	36.1	123.3	7.81	.43	.62	.81	33.0	112.7	9.45	.45	.65	.87	29.6	101.1	11.51	.46	.69	.94

COOLING RATINGS

NOTE - For Temperatures and Capacities not shown in tables, see bulletin - Cooling Unit Rating Table Correction Factor Data in Miscellaneous Engineering Data section.

44 kW STANDARD EFFICIENCY COOLING CAPACITY - ONE COMPRESSOR OPERATING

LGC150S2

Entering Wet Bulb Temperature	Total Air Volume		Outdoor Air Temperature Entering Outdoor Coil																							
			18°C (65°F)						24°C (75°F)						29°C (85°F)						35°C (95°F)					
			Total Cooling Capacity		Comp Motor kW Input	Sensible To Total Ratio (S/T) Dry Bulb			Total Cooling Capacity		Comp Motor kW Input	Sensible To Total Ratio (S/T) Dry Bulb			Total Cooling Capacity		Comp Motor kW Input	Sensible To Total Ratio (S/T) Dry Bulb			Total Cooling Capacity		Comp Motor kW Input	Sensible To Total Ratio (S/T) Dry Bulb		
			kW	kBtuh		24°C 75°F	27°C 80°F	29°C 85°F	kW	kBtuh		24°C 75°F	27°C 80°F	29°C 85°F	kW	kBtuh		24°C 75°F	27°C 80°F	29°C 85°F	kW	kBtuh		24°C 75°F	27°C 80°F	29°C 85°F
17°C (63°F)	1.79	3800	19.2	65.5	3.52	.62	.80	.97	18.6	63.5	3.91	.63	.82	.99	18.1	61.6	4.36	.64	.84	1.00	17.4	59.5	4.87	.65	.86	1.00
	2.07	4400	19.7	67.1	3.56	.66	.87	1.00	19.1	65.1	3.94	.67	.89	1.00	18.5	63.1	4.39	.69	.91	1.00	17.8	60.9	4.91	.71	.93	1.00
	2.36	5000	20.1	68.5	3.58	.71	.93	1.00	19.5	66.5	3.98	.72	.95	1.00	18.9	64.4	4.42	.74	.97	1.00	18.3	62.3	4.94	.76	.99	1.00
19°C (67°F)	1.79	3800	20.3	69.3	3.60	.49	.60	.76	19.7	67.2	3.99	.49	.61	.77	19.0	65.0	4.44	.50	.62	.79	18.4	62.8	4.95	.50	.63	.82
	2.07	4400	20.7	70.6	3.63	.51	.63	.82	20.1	68.5	4.02	.51	.64	.84	19.4	66.3	4.47	.52	.66	.87	18.7	63.9	4.98	.52	.68	.89
	2.36	5000	21.0	71.7	3.66	.52	.68	.89	20.4	69.5	4.05	.53	.70	.91	19.7	67.3	4.49	.54	.71	.93	19.0	64.9	5.01	.54	.73	.96
22°C (71°F)	1.79	3800	21.6	73.6	3.70	.36	.47	.58	20.9	71.4	4.09	.37	.48	.59	20.3	69.1	4.54	.37	.48	.60	19.5	66.7	5.05	.37	.49	.61
	2.07	4400	22.0	74.9	3.73	.38	.49	.61	21.3	72.6	4.12	.37	.50	.62	20.6	70.3	4.57	.37	.51	.64	19.9	67.8	5.08	.38	.51	.65
	2.36	5000	22.2	75.9	3.76	.38	.51	.65	21.6	73.6	4.15	.38	.52	.67	20.9	71.2	4.59	.38	.53	.68	20.1	68.6	5.10	.39	.54	.71

44 kW STANDARD EFFICIENCY COOLING CAPACITY - ALL COMPRESSORS OPERATING

LGC150S2

Entering Wet Bulb Temperature	Total Air Volume		Outdoor Air Temperature Entering Outdoor Coil																							
			27°C (80°F)						35°C (95°F)						43°C (110°F)						52°C (125°F)					
			Total Cooling Capacity		Comp Motor kW Input	Sensible To Total Ratio (S/T) Dry Bulb			Total Cooling Capacity		Comp Motor kW Input	Sensible To Total Ratio (S/T) Dry Bulb			Total Cooling Capacity		Comp Motor kW Input	Sensible To Total Ratio (S/T) Dry Bulb			Total Cooling Capacity		Comp Motor kW Input	Sensible To Total Ratio (S/T) Dry Bulb		
			kW	kBtuh		24°C 75°F	27°C 80°F	29°C 85°F	kW	kBtuh		24°C 75°F	27°C 80°F	29°C 85°F	kW	kBtuh		24°C 75°F	27°C 80°F	29°C 85°F	kW	kBtuh		24°C 75°F	27°C 80°F	29°C 85°F
17°C (63°F)	1.79	3800	38.0	129.8	8.48	.69	.85	.99	36.1	123.3	10.01	.70	.87	1.00	34.0	116.1	11.88	.72	.91	1.00	31.7	108.2	14.13	.75	.95	1.00
	2.07	4400	38.9	132.9	8.54	.72	.90	1.00	37.0	126.3	10.08	.74	.93	1.00	34.9	119.1	11.95	.77	.97	1.00	32.6	111.4	14.20	.81	.99	1.00
	2.36	5000	39.8	135.8	8.60	.76	.95	1.00	37.8	129.1	10.15	.79	.98	1.00	35.8	122.1	12.02	.82	1.00	1.00	33.6	114.5	14.30	.86	1.00	1.00
19°C (67°F)	1.79	3800	40.2	137.2	8.64	.53	.66	.81	38.2	130.3	10.17	.54	.68	.83	35.9	122.6	12.04	.55	.70	.87	33.4	114.1	14.30	.57	.72	.91
	2.07	4400	41.0	139.9	8.70	.55	.70	.87	38.9	132.7	10.24	.57	.72	.90	36.6	124.8	12.11	.58	.74	.93	34.0	116.1	14.38	.60	.78	.97
	2.36	5000	41.6	142.0	8.75	.58	.74	.92	39.5	134.8	10.29	.59	.76	.95	37.1	126.7	12.16	.60	.80	.98	34.5	117.8	14.43	.62	.84	1.00
22°C (71°F)	1.79	3800	42.8	145.9	8.84	.40	.52	.64	40.6	138.4	10.38	.40	.53	.66	38.2	130.3	12.25	.41	.54	.68	35.5	121.3	14.53	.41	.56	.70
	2.07	4400	43.5	148.4	8.90	.41	.54	.68	41.3	140.8	10.45	.41	.55	.70	38.8	132.4	12.32	.41	.57	.72	36.1	123.2	14.58	.42	.59	.75
	2.36	5000	44.1	150.4	8.95	.41	.56	.71	41.8	142.5	10.49	.42	.58	.74	39.3	134.0	12.37	.43	.59	.77	36.5	124.6	14.64	.43	.62	.81

44 kW STANDARD EFFICIENCY (R-410A) COOLING CAPACITY - ONE COMPRESSOR OPERATING

LGC150S4

Entering Wet Bulb Temperature	Total Air Volume		Outdoor Air Temperature Entering Outdoor Coil																							
			18°C (65°F)						24°C (75°F)						29°C (85°F)						35°C (95°F)					
			Total Cooling Capacity		Comp Motor kW Input	Sensible To Total Ratio (S/T) Dry Bulb			Total Cooling Capacity		Comp Motor kW Input	Sensible To Total Ratio (S/T) Dry Bulb			Total Cooling Capacity		Comp Motor kW Input	Sensible To Total Ratio (S/T) Dry Bulb			Total Cooling Capacity		Comp Motor kW Input	Sensible To Total Ratio (S/T) Dry Bulb		
			kW	kBtuh		24°C 75°F	27°C 80°F	29°C 85°F	kW	kBtuh		24°C 75°F	27°C 80°F	29°C 85°F	kW	kBtuh		24°C 75°F	27°C 80°F	29°C 85°F	kW	kBtuh		24°C 75°F	27°C 80°F	29°C 85°F
17°C (63°F)	1.79	3800	21.9	74.7	3.67	.54	.75	.96	21.1	72.0	4.10	.55	.78	.99	20.3	69.1	4.58	.56	.81	1.00	19.3	66.0	5.13	.58	.85	1.00
	2.07	4400	22.4	76.5	3.70	.58	.83	1.00	21.6	73.8	4.13	.60	.86	1.00	20.7	70.8	4.61	.62	.90	1.00	19.8	67.6	5.16	.65	.94	1.00
	2.36	5000	22.9	78.1	3.73	.64	.91	1.00	22.1	75.4	4.16	.66	.94	1.00	21.2	72.4	4.64	.69	.97	1.00	20.3	69.3	5.20	.72	.99	1.00
19°C (67°F)	1.79	3800	23.2	79.0	3.74	.42	.53	.69	22.3	76.1	4.17	.43	.53	.72	21.4	73.0	4.66	.44	.54	.75	20.4	69.7	5.21	.44	.56	.79
	2.07	4400	23.6	80.6	3.77	.44	.55	.78	22.7	77.6	4.20	.45	.56	.81	21.8	74.4	4.68	.45	.59	.84	20.8	70.9	5.24	.46	.62	.89
	2.36	5000	24.0	81.8	3.80	.46	.60	.86	23.1	78.8	4.22	.46	.62	.89	22.1	75.5	4.71	.47	.65	.93	21.1	72.0	5.26	.48	.69	.96
22°C (71°F)	1.79	3800	24.6	83.9	3.83	.32	.41	.51	23.7	80.9	4.26	.32	.42	.52	22.7	77.6	4.75	.32	.42	.53	21.7	74.1	5.30	.32	.43	.54
	2.07	4400	25.0	85.4	3.86	.32	.43	.54	24.1	82.3	4.29	.33	.44	.55	23.2	79.0	4.77	.33	.44	.56	22.1	75.3	5.32	.33	.45	.58
	2.36	5000	25.4	86.5	3.88	.33	.45	.57	24.4	83.4	4.31	.33	.46	.59	23.4	79.9	4.79	.34	.46	.62	22.3	76.1	5.35	.34	.47	.65

44 kW STANDARD EFFICIENCY (R-410A) COOLING CAPACITY - ALL COMPRESSORS OPERATING

LGC150S4

Entering Wet Bulb Temperature	Total Air Volume		Outdoor Air Temperature Entering Outdoor Coil																							
			27°C (80°F)						35°C (95°F)						43°C (110°F)						52°C (125°F)					
			Total Cooling Capacity		Comp Motor kW Input	Sensible To Total Ratio (S/T) Dry Bulb			Total Cooling Capacity		Comp Motor kW Input	Sensible To Total Ratio (S/T) Dry Bulb			Total Cooling Capacity		Comp Motor kW Input	Sensible To Total Ratio (S/T) Dry Bulb			Total Cooling Capacity		Comp Motor kW Input	Sensible To Total Ratio (S/T) Dry Bulb		
			kW	kBtuh		24°C 75°F	27°C 80°F	29°C 85°F	kW	kBtuh		24°C 75°F	27°C 80°F	29°C 85°F	kW	kBtuh		24°C 75°F	27°C 80°F	29°C 85°F	kW	kBtuh		24°C 75°F	27°C 80°F	29°C 85°F
17°C (63°F)	1.79	3800	40.0	136.6	8.42	.64	.82	.99	37.4	127.5	10.01	.66	.87	1.00	34.4	117.4	11.95	.69	.92	1.00	31.1	106.1	14.36	.75	.99	1.00
	2.07	4400	41.0	139.8	8.48	.67	.89	1.00	38.2	130.5	10.07	.70	.93	1.00	35.3	120.3	12.02	.75	.98	1.00	32.0	109.3	14.46	.82	1.00	1.00
	2.36	5000	41.8	142.5	8.54	.71	.95	1.00	39.1	133.3	10.12	.76	.98	1.00	36.1	123.3	12.11	.81	1.00	1.00	32.9	112.2	14.54	.89	1.00	1.00
19°C (67°F)	1.79	3800	42.3	144.4	8.57	.50	.62	.78	39.4	134.5	10.15	.51	.64	.82	36.1	123.3	12.12	.52	.67	.88	32.4	110.7	14.52	.55	.72	.95
	2.07	4400	43.1	146.9	8.61	.51	.65	.85	40.1	136.7	10.21	.53	.67	.90	36.8	125.4	12.16	.55	.72	.95	33.0	112.6	14.57	.57	.79	1.00
	2.36	5000	43.7	149.0	8.65	.53	.68	.91	40.6	138.6	10.26	.55	.73	.96	37.3	127.2	12.20	.57	.78	.99	33.4	114.1	14.63	.60	.86	1.00
22°C (71°F)	1.79	3800	44.9	153.2	8.75	.37	.48	.60	41.9	142.8	10.34	.37	.50	.62	38.4	130.9	12.32	.38	.51	.65	34.5	117.7	14.71	.39	.54	.69
	2.07	4400	45.6	155.7	8.80	.38	.50	.63	42.5	144.9	10.40	.38	.52	.66	38.9	132.9	12.36	.39	.54	.69	35.0	119.3	14.77	.40	.57	.76
	2.36	5000	46.2	157.7	8.84	.38	.52	.66	43.0	146.6	10.43	.39	.54	.70	39.4	134.3	12.40	.40	.56	.76	35.3	120.3	14.80	.41	.60	.83

BLOWER DATA

BELT DRIVE BLOWER - BASE UNIT

BLOWER TABLE INCLUDES RESISTANCE FOR BASE UNIT ONLY (NO HEAT SECTION) WITH DRY INDOOR COIL AND AIR FILTERS IN PLACE. FOR ALL UNITS ADD:

- 1 - Wet indoor coil air resistance of selected unit.
- 2 - Any factory installed options air resistance (heat section, economizer, etc.)
- 3 - Any field installed accessories air resistance (duct resistance, diffuser, etc.)

Then determine from blower table blower motor output and drive required.

See below for blower motors and drives. See page 18 for wet coil and option/accessory air resistance data.

BOLD INDICATES FIELD FURNISHED DRIVE.

Air Volume L/s (cfm)	Total Static Pressure - Pa (in. w.g.)																										
	50 (.20)		100 (.40)		150 (.60)		200 (.80)		250 (1.00)		300 (1.20)		350 (1.40)		400 (1.60)		450 (1.80)		495 (2.00)		2.20 (545)		2.40 (595)		2.60 (645)		
	rev/ min	BHP (kW)	rev/ min	BHP (kW)	rev/ min	BHP (kW)	rev/ min	BHP (kW)	rev/ min	BHP (kW)	rev/ min	BHP (kW)	rev/ min	BHP (kW)	rev/ min	BHP (kW)	rev/ min	BHP (kW)	rev/ min	BHP (kW)	rev/ min	BHP (kW)	rev/ min	BHP (kW)	rev/ min	BHP (kW)	rev/ min
1060 (2250)	455	0.30 (0.22)	555	0.45 (0.34)	640	0.60 (0.45)	720	0.80 (0.60)	790	1.00 (0.75)	855	1.20 (0.90)	915	1.40 (1.04)	975	1.60 (1.19)	1030	1.85 (1.38)	1080	2.05 (1.53)	1130	2.30 (1.72)	1175	2.55 (1.90)	1220	2.80 (2.09)	
1180 (2500)	475	0.40 (0.30)	575	0.55 (0.41)	660	0.70 (0.52)	735	0.90 (0.67)	805	1.10 (0.82)	870	1.30 (0.97)	930	1.55 (1.16)	985	1.75 (1.31)	1040	2.00 (1.49)	1090	2.25 (1.68)	1140	2.50 (1.87)	1185	2.75 (2.05)	1230	3.00 (2.24)	
1300 (2750)	495	0.45 (0.34)	595	0.65 (0.48)	675	0.85 (0.63)	750	1.05 (0.78)	820	1.25 (0.93)	885	1.45 (1.08)	940	1.70 (1.27)	995	1.90 (1.42)	1050	2.20 (1.64)	1100	2.45 (1.83)	1145	2.65 (1.98)	1195	2.95 (2.20)	1240	3.25 (2.42)	
1415 (3000)	525	0.55 (0.41)	615	0.75 (0.56)	695	0.95 (0.71)	770	1.20 (0.90)	835	1.40 (1.04)	895	1.60 (1.19)	955	1.85 (1.38)	1010	2.10 (1.57)	1060	2.35 (1.75)	1110	2.65 (1.98)	1160	2.90 (2.16)	1205	3.20 (2.39)	1250	3.45 (2.57)	
1535 (3250)	550	0.65 (0.48)	640	0.90 (0.67)	715	1.10 (0.82)	790	1.35 (1.01)	855	1.60 (1.19)	915	1.80 (1.34)	970	2.05 (1.53)	1025	2.35 (1.75)	1075	2.60 (1.94)	1125	2.85 (2.13)	1170	3.15 (2.35)	1215	3.40 (2.54)	1260	3.70 (2.76)	
1650 (3500)	580	0.80 (0.60)	665	1.05 (0.78)	740	1.25 (0.93)	810	1.50 (1.12)	870	1.75 (1.31)	930	2.00 (1.49)	985	2.25 (1.68)	1040	2.55 (1.90)	1090	2.85 (2.13)	1135	3.10 (2.31)	1185	3.40 (2.54)	1230	3.70 (2.76)	1270	4.00 (2.98)	
1770 (3750)	605	0.95 (0.71)	690	1.20 (0.90)	760	1.45 (1.08)	830	1.70 (1.27)	890	1.95 (1.45)	950	2.25 (1.68)	1005	2.50 (1.87)	1055	2.80 (2.09)	1105	3.10 (2.31)	1150	3.35 (2.50)	1195	3.65 (2.72)	1240	3.95 (2.95)	1285	4.30 (3.21)	
1890 (4000)	635	1.10 (0.82)	715	1.40 (1.04)	785	1.65 (1.23)	850	1.90 (1.42)	910	2.20 (1.64)	965	2.45 (1.83)	1020	2.75 (2.05)	1070	3.05 (2.28)	1120	3.35 (2.50)	1165	3.65 (2.72)	1210	3.95 (2.95)	1255	4.30 (3.21)	1295	4.60 (3.43)	
2005 (4250)	665	1.30 (0.97)	740	1.60 (1.19)	810	1.85 (1.38)	870	2.15 (1.60)	930	2.45 (1.83)	985	2.75 (2.05)	1040	3.05 (2.28)	1090	3.35 (2.50)	1135	3.65 (2.72)	1185	4.00 (2.98)	1225	4.30 (3.21)	1270	4.65 (3.47)	1310	4.95 (3.69)	
2125 (4500)	695	1.50 (1.12)	770	1.80 (1.34)	835	2.10 (1.57)	895	2.40 (1.79)	955	2.70 (2.01)	1005	3.00 (2.24)	1060	3.35 (2.50)	1105	3.65 (2.72)	1155	4.00 (2.98)	1200	4.30 (3.21)	1245	4.65 (3.47)	1285	5.00 (3.73)	1325	5.30 (3.95)	
2240 (4750)	725	1.75 (1.31)	795	2.05 (1.53)	860	2.40 (1.79)	920	2.70 (2.01)	975	3.00 (2.24)	1030	3.35 (2.50)	1080	3.65 (2.72)	1125	3.95 (2.95)	1175	4.35 (3.25)	1215	4.65 (3.47)	1260	5.00 (3.73)	1300	5.35 (3.99)	1340	5.70 (4.25)	
2360 (5000)	760	2.05 (1.53)	825	2.35 (1.75)	885	2.65 (1.98)	945	3.00 (2.24)	1000	3.35 (2.50)	1050	3.65 (2.72)	1100	4.00 (2.98)	1145	4.35 (3.25)	1190	4.70 (3.51)	1235	5.05 (3.77)	1280	5.45 (4.07)	---	---	---	---	
2475 (5250)	790	2.30 (1.72)	855	2.65 (1.98)	910	2.95 (2.20)	970	3.35 (2.50)	1020	3.65 (2.72)	1070	4.00 (2.98)	1120	4.35 (3.25)	1165	4.70 (3.51)	1210	5.10 (3.80)	1255	5.45 (4.07)	---	---	---	---	---	---	
2595 (5500)	820	2.60 (1.94)	880	2.95 (2.20)	940	3.30 (2.46)	995	3.70 (2.76)	1045	4.05 (3.02)	1095	4.40 (3.28)	1145	4.80 (3.58)	1190	5.15 (3.84)	1230	5.50 (4.10)	---	---	---	---	---	---	---	---	
2715 (5750)	850	2.95 (2.20)	910	3.30 (2.46)	965	3.70 (2.76)	1020	4.05 (3.02)	1070	4.45 (3.32)	1120	4.80 (3.58)	1165	5.20 (3.88)	1210	5.60 (4.18)	---	---	---	---	---	---	---	---	---	---	
2830 (6000)	885	3.35 (2.50)	940	3.70 (2.76)	995	4.10 (3.06)	1045	4.45 (3.32)	1095	4.85 (3.62)	1145	5.25 (3.92)	1190	5.65 (4.21)	---	---	---	---	---	---	---	---	---	---	---	---	

FACTORY INSTALLED BELT DRIVE KIT SPECIFICATIONS

Motor Efficiency	Motor Outputs				rev/min Range				
	Nominal kW	hp	Maximum kW	hp	Drive 1	Drive 2	Drive 3	Drive 4	Drive 6
Standard	1.5	2	1.7	2.3	567 - 771	---	746 - 933	---	---
Standard	2.2	3	2.6	3.45	---	567 - 771	---	746 - 933	925 - 1163
Standard	3.7	5	4.3	5.75	---	---	---	746 - 933	925 - 1163

NOTE - Using total air volume and system static pressure requirements determine from blower performance tables rev/min and motor output required. Maximum usable output of motors furnished by Lennox are shown. If motors of comparable output are used, be sure to keep within the service factor limitations outlined on the motor nameplate.

BLOWER DATA

FACTORY INSTALLED OPTIONS/FIELD INSTALLED ACCESSORY AIR RESISTANCE

Air Volume		Wet Indoor Coil				Gas Heat Exchanger						Economizer		Filters			
		090, 102		120,150		Standard Heat		Medium Heat		High Heat				MERV 11		MERV 15	
L/s	cfm	Pa	in. w.g.	Pa	in. w.g.	Pa	in. w.g.	Pa	in. w.g.	Pa	in. w.g.	Pa	in. w.g.	Pa	in. w.g.	Pa	in. w.g.
1060	2250	15	0.06	25	0.10	12	0.05	17	0.07	22	0.09	9	0.035	2	0.01	10	0.04
1180	2500	20	0.08	30	0.12	12	0.05	22	0.09	27	0.11	10	0.04	2	0.01	12	0.05
1325	2750	22	0.09	35	0.14	15	0.06	25	0.10	32	0.13	11	0.045	5	0.02	12	0.05
1420	3000	25	0.10	40	0.16	17	0.07	30	0.12	40	0.16	12	0.05	5	0.02	15	0.06
1535	3250	27	0.11	47	0.19	20	0.08	37	0.15	47	0.19	15	0.06	5	0.02	15	0.06
1650	3500	32	0.13	52	0.21	22	0.09	42	0.17	55	0.22	17	0.07	7	0.03	17	0.07
1770	3750	35	0.14	57	0.23	25	0.10	50	0.20	65	0.26	19	0.075	7	0.03	20	0.08
1890	4000	40	0.16	65	0.26	27	0.11	55	0.22	75	0.30	20	0.08	10	0.04	20	0.08
2005	4250	42	0.17	70	0.28	30	0.12	62	0.25	85	0.34	22	0.09	10	0.04	22	0.09
2125	4500	45	0.18	77	0.31	32	0.13	70	0.28	94	0.38	25	0.10	10	0.04	22	0.09
2240	4750	50	0.20	82	0.33	35	0.14	77	0.31	104	0.42	27	0.11	12	0.05	25	0.10
2360	5000	55	0.22	90	0.36	40	0.16	87	0.35	117	0.47	30	0.12	15	0.06	25	0.10
2475	5250	60	0.24	97	0.39	45	0.18	94	0.38	129	0.52	32	0.13	15	0.06	27	0.11
2595	5500	65	0.26	104	0.42	50	0.20	104	0.42	142	0.57	35	0.14	17	0.07	30	0.12
2715	5750	70	0.28	112	0.45	55	0.22	114	0.46	154	0.62	37	0.15	17	0.07	30	0.12
2830	6000	75	0.30	119	0.48	60	0.24	124	0.50	169	0.68	40	0.16	20	0.08	32	0.13

AIR RESISTANCE - CEILING DIFFUSERS

Unit Size	Air Volume		RTD11 Step-Down Diffuser						FD11 Flush Diffuser	
			2 Ends Open		1 Side, 2 Ends Open		All Ends & Sides Open			
	L/s	cfm	Pa	in. w.g.	Pa	in. w.g.	Pa	in. w.g.	Pa	in. w.g.
090 Models	1135	2400	52	0.21	45	0.18	37	0.15	35	0.14
	1225	2600	60	0.24	52	0.21	45	0.18	42	0.17
	1320	2800	67	0.27	60	0.24	52	0.21	50	0.20
	1415	3000	80	0.32	72	0.29	62	0.25	62	0.25
	1510	3200	102	0.41	92	0.37	80	0.32	77	0.31
	1605	3400	124	0.50	112	0.45	97	0.39	92	0.37
	1700	3600	152	0.61	134	0.54	119	0.48	109	0.44
102 & 120 Models	1795	3800	182	0.73	157	0.63	142	0.57	127	0.51
	1700	3600	90	0.36	70	0.28	57	0.23	37	0.15
	1795	3800	99	0.40	80	0.32	65	0.26	45	0.18
	1890	4000	109	0.44	90	0.36	72	0.29	52	0.21
	1980	4200	122	0.49	99	0.40	82	0.33	60	0.24
	2075	4400	134	0.54	109	0.44	92	0.37	67	0.27
	2170	4600	149	0.60	122	0.49	104	0.42	77	0.31
150 Models	2265	4800	162	0.65	132	0.53	114	0.46	87	0.35
	2360	5000	172	0.69	144	0.58	124	0.50	97	0.39
	2455	5200	186	0.75	154	0.62	134	0.54	107	0.43
	1980	4200	55	0.22	47	0.19	40	0.16	25	0.10
	2075	4400	70	0.28	60	0.24	50	0.20	30	0.12
	2170	4600	85	0.34	72	0.29	60	0.24	37	0.15
	2265	4800	99	0.40	85	0.34	72	0.29	47	0.19
150 Models	2360	5000	114	0.46	97	0.39	85	0.34	57	0.23
	2455	5200	129	0.52	109	0.44	97	0.39	67	0.27
	2550	5400	144	0.58	122	0.49	107	0.43	77	0.31
	2645	5600	159	0.64	134	0.54	117	0.47	87	0.35
	2735	5800	174	0.70	147	0.59	127	0.51	97	0.39

BLOWER DATA

CEILING DIFFUSER AIR THROW DATA

Model No.	Air Volume		¹ Effective Throw Range			
			RTD11 Step-Down		FD11 Flush	FD11 Flush
	L/s	cfm	m	ft.	m	ft.
090	1225	2600	7 - 9	24 - 29	6 - 7	19 - 24
	1320	2800	8 - 9	25 - 30	6 - 9	20 - 28
	1415	3000	8 - 10	27 - 33	6 - 9	21 - 29
	1510	3200	9 - 11	28 - 35	7 - 9	22 - 29
	1605	3400	9 - 11	30 - 37	7 - 9	22 - 30
102 120	1700	3600	8 - 10	25 - 33	7 - 9	22 - 29
	1795	3800	8 - 11	27 - 35	7 - 9	22 - 30
	1885	4000	9 - 11	29 - 37	7 - 10	24 - 33
	1980	4200	10 - 12	32 - 40	8 - 11	26 - 35
	2075	4400	10 - 13	34 - 42	9 - 11	28 - 37
150	2645	5600	12 - 15	39 - 49	9 - 11	28 - 37
	2740	5800	13 - 16	42 - 51	9 - 12	29 - 38
	2830	6000	13 - 17	44 - 54	12 - 15	40 - 50
	2925	6200	14 - 17	45 - 55	13 - 16	42 - 51
	3020	6400	14 - 17	46 - 55	13 - 16	43 - 52
	3115	6600	14 - 17	47 - 56	14 - 17	45 - 56

¹ Throw is the horizontal or vertical distance an air stream travels on leaving the outlet or diffuser before the maximum velocity is reduced to 50 ft. (15 m) per minute. Four sides open.

POWER EXHAUST FANS PERFORMANCE

Return Air System Static Pressure		Air Volume Exhausted	
Pa	in. w.g.	L/s	cfm
0	0	1650	3500
12	0.05	1563	3308
25	0.10	1475	3125
37	0.15	1383	2933
50	0.20	1300	2750
62	0.25	1213	2566
75	0.30	1125	2383
87	0.35	1038	2200

OUTDOOR SOUND DATA

Unit Model No.	Octave Band Sound Power Levels dBA, re 10 ⁻¹² Watts							¹ Sound Rating Number (dB)
	Center Frequency - HZ							
	125	250	500	1000	2000	4000	8000	
090, 102, and 120	76	79	84	83	79	73	66	88
150	77	80	85	84	79	74	66	88

NOTE - The octave sound power data shown does not include tonal correction.

¹ Tested according to ARI Standard 270-95 test conditions and ANSI Standard S1.32-1981.

ELECTRICAL DATA

		LGC090S2			LGA090H2			LGA090H4		
Voltage - 50hz - 3 phase with neutral		380/420V			380/420V			380/420V		
Compressors (2)	Rated Load Amps - each (total)	6.4 (12.8)			6.4 (12.8)			7.1 (14.2)		
	Locked Rotor Amps - each (total)	46 (92)			44 (88)			46 (92)		
Outdoor Fan Motors (2)	Full Load Amps - each (total)	1.3 (2.6)			1.3 (2.6)			1.3 (2.6)		
	Locked Rotor Amps - each (total)	2.4 (4.8)			2.4 (4.8)			2.4 (4.8)		
Power Exhaust Fan	Watts (Horsepower)	249 (1/3)			249 (1/3)			249 (1/3)		
	Full Load Amps	1.3			1.3			1.3		
	Locked Rotor Amps	2.4			2.4			2.4		
Indoor Blower Motor	kilowatts (hp)	1.5 (2)	2.2 (3)	3.7 (5)	1.5 (2)	2.2 (3)	3.7 (5)	1.5 (2)	2.2 (3)	3.7 (5)
	Rated Load Amps	3.5	5.0	7.8	3.5	5.0	7.8	3.5	5.0	7.8
	Locked Rotor Amps	22.1	27.0	41.0	22.1	27.0	41.0	22.1	27.0	41.0
¹ Maximum Overcurrent Protection	Unit only	25	25	30	25	25	30	25	30	30
	with power exhaust	25	25	30	25	25	30	30	30	35
² Minimum Circuit Ampacity	Unit only	21	22	25	21	22	25	23	24	27
	with power exhaust	22	24	27	22	24	27	24	25	28
Disconnect		84M13			84M13			84M13		
		LGC102S2			LGA102H2			LGA102H4		
Voltage - 50hz - 3 phase with neutral		380/420V			380/420V			380/420V		
Compressors (2)	Rated Load Amps - each (total)	7.1 (14.2)			7.1 (14.2)			7.9 (15.8)		
	Locked Rotor Amps - each (total)	50 (100)			50 (100)			46 (92)		
Outdoor Fan Motors (2)	Full Load Amps - each (total)	1.3 (2.6)			1.3 (2.6)			1.3 (2.6)		
	Locked Rotor Amps - each (total)	2.4 (4.8)			2.4 (4.8)			2.4 (4.8)		
Power Exhaust Fan	Watts (Horsepower)	249 (1/3)			249 (1/3)			249 (1/3)		
	Full Load Amps	1.3			1.3			1.3		
	Locked Rotor Amps	2.4			2.4			2.4		
Indoor Blower Motor	Watts	1.5 (2)	2.2 (3)	3.7 (5)	1.5 (2)	2.2 (3)	3.7 (5)	1.5 (2)	2.2 (3)	3.7 (5)
	Rated Load Amps	3.5	5.0	7.8	3.5	5.0	7.8	3.5	5.0	7.8
	Locked Rotor Amps	22.1	27.0	41.0	22.1	27.0	41.0	22.1	27.0	41.0
¹ Maximum Overcurrent Protection	Unit only	25	30	30	25	30	30	30	30	35
	with power exhaust	30	30	35	30	30	35	30	30	35
² Minimum Circuit Ampacity	Unit only	23	24	27	23	24	27	24	26	29
	with power exhaust	24	25	28	24	25	28	26	27	30
Disconnect		84M13			84M13			84M13		
		LGC120S2			LGA120H2			LGA120H4		
Voltage - 50hz - 3 phase with neutral		380/420V			380/420V			380/420V		
Compressors (2)	Rated Load Amps - each (total)	7.4 (14.8)			9.0 (18.0)			7.8 (15.6)		
	Locked Rotor Amps - each (total)	59.6 (119.2)			62 (124)			52 (104)		
Outdoor Fan Motors (2)	Full Load Amps - each (total)	1.3 (2.6)			1.3 (2.6)			1.3 (2.6)		
	Locked Rotor Amps - each (total)	2.4 (4.8)			2.4 (4.8)			2.4 (4.8)		
Power Exhaust Fan	Watts (Horsepower)	249 (1/3)			249 (1/3)			249 (1/3)		
	Full Load Amps	1.3			1.3			1.3		
	Locked Rotor Amps	2.4			2.4			2.4		
Indoor Blower Motor	Watts	1.5 (2)	2.2 (3)	3.7 (5)	1.5 (2)	2.2 (3)	3.7 (5)	1.5 (2)	2.2 (3)	3.7 (5)
	Rated Load Amps	3.5	5.0	7.8	3.5	5.0	7.8	3.5	5.0	7.8
	Locked Rotor Amps	22.1	27.0	41.0	22.1	27.0	41.0	22.1	27.0	41.0
¹ Maximum Overcurrent Protection	Unit only	30	30	35	35	35	35	30	30	35
	with power exhaust	30	30	35	35	35	40	30	30	35
² Minimum Circuit Ampacity	Unit only	23	25	28	27	28	31	24	26	28
	with power exhaust	25	26	29	28	30	32	25	27	30
Disconnect		84M13			84M13			84M13		

NOTE - Extremes of operating range are plus and minus 10% of line voltage.

¹ HACR type breaker or fuse.

² Refer to local electrical codes to determine wire, fuse and disconnect size requirements.

³ Factory installed circuit breaker not available.

ELECTRICAL DATA

		LGC150S2			LGC150S4		
Voltage - 50hz - 3 phase with neutral		380/420V			380/420V		
Compressors (2)	Rated Load Amps - each (total)	9 (18)			10.6 (21.2)		
	Locked Rotor Amps - each (total)	75 (150)			75 (150)		
Outdoor Fan Motors (2)	Full Load Amps - each (total)	1.5 (3.0)			1.5 (3.0)		
	Locked Rotor Amps - each (total)	3.0 (6.0)			3.0 (6.0)		
Power Exhaust Fan	Watts (Horsepower)	249 (1/3)			249 (1/3)		
	Full Load Amps	1.3			1.3		
	Locked Rotor Amps	2.4			2.4		
Indoor Blower Motor	Horsepower	1.5 (2)	2.2 (3)	3.7 (5)	1.5 (2)	2.2 (3)	3.7 (5)
	Rated Load Amps	3.5	5.0	7.8	3.5	5.0	7.8
	Locked Rotor Amps	22.1	27.0	41.0	22.1	27.0	41.0
¹ Maximum Overcurrent Protection	Unit only	35	35	40	40	40	45
	with power exhaust	35	35	40	40	40	45
² Minimum Circuit Ampacity	Unit only	27	29	32	31	32	35
	with power exhaust	29	30	33	32	34	36
Disconnect		84M13			84M13		

NOTE - Extremes of operating range are plus and minus 10% of line voltage.

¹ Refer to local electrical codes to determine wire, fuse and disconnect size requirements.

² HACR type breaker or fuse.

³ Factory installed circuit breaker not available.

UNIT CLEARANCES - MM (INCHES)

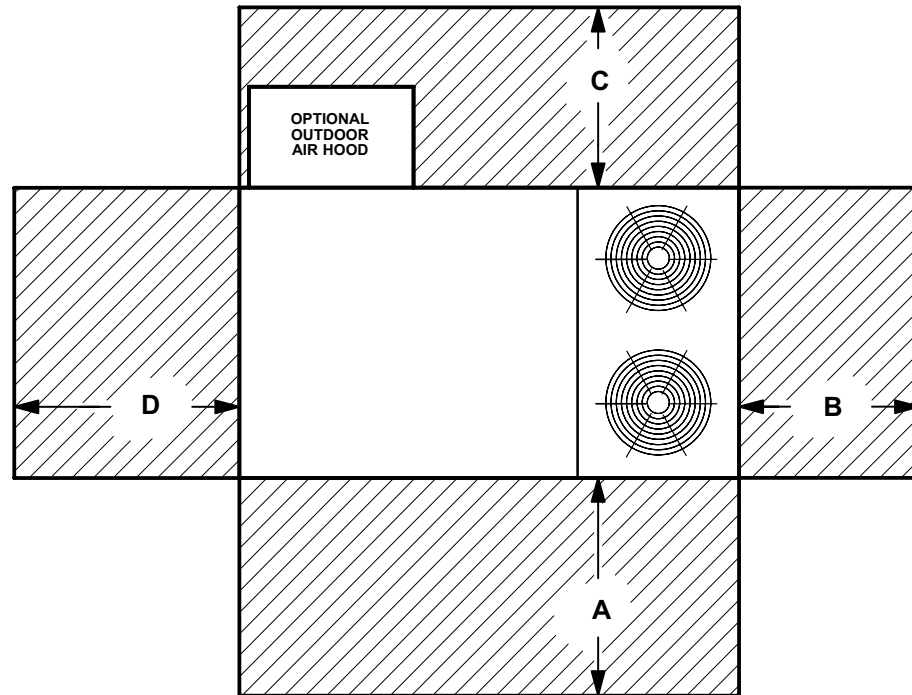

¹ Unit Clearance	A		B		C		D		Top Clearance
	mm	in.	mm	in.	mm	in.	mm	in.	
Service Clearance	1524	60	914	36	914	36	1676	66	Unobstructed
Clearance to Combustibles	914	36	25	1	25	1	25	1	
Minimum Operation Clearance	914	36	914	36	914	36	914	36	

NOTE - Entire perimeter of unit base requires support when elevated above the mounting surface.

¹ Service Clearance - Required for removal of serviceable parts.

Clearance to Combustibles - Required clearance to combustible material.

Minimum Operation Clearance - Required clearance for proper unit operation.

OPTIONAL CONVENTIONAL TEMPERATURE CONTROL SYSTEMS - FIELD INSTALLED

COMMERCIAL TOUCHSCREEN THERMOSTAT



Intuitive Touchscreen Interface - **Two Stage Heating / Two Stage Cooling Conventional or Heat Pump** - Seven Day Programmable - Four Time Periods/Day - Economizer Output - Title 24 Compliant - ENERGY STAR® Qualified - Backlit Display - Automatic Changeover

C0STAT02AE1L

Sensors For Touchscreen Thermostat

¹ Remote non-adjustable wall mount 20k temperature sensor	C0SNZN01AE1-
¹ Remote non-adjustable wall mount 10k averaging temperature sensor	C0SNZN73AE1-
¹ Remote non-adjustable duct mount temperature sensor	C0SNDC00AE1-
Outdoor temperature sensor	C0SNSR03AE1-

Accessories For Touchscreen Thermostat

Locking cover (clear)	C0MISC15AE1-
-----------------------------	--------------

¹ Remote sensors for C0STAT02AE1L can be applied in the following combinations: (1) C0SNZN01AE1-, (2) C0SNZN73AE1-, (2) C0SNZN01AE1- and (1) C0SNZN73AE1-, (4) C0SNZN01AE1-, (3) C0SNZN01AE1- and (2) C0SNZN73AE1.

DIGITAL NON-PROGRAMMABLE THERMOSTATS



Intuitive Interface - Automatic Changeover - Simple Up and Down Temperature Control

Two-stage heating / cooling conventional systems	C0STAT10AE1L
---	--------------

Sensor For Digital Non-Programmable Thermostats Above

Remote wall mounted temperature sensor	C0SNZN00AE1-
--	--------------

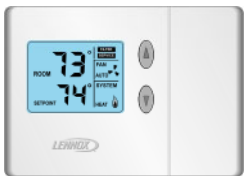

Intuitive Interface - Automatic Changeover - Backlit Display - Simple Up and Down Temperature Control

One-stage heating / cooling conventional systems	C0STAT12AE1L
---	--------------

Sensor For Digital Non-Programmable Thermostats Above

Outdoor temperature sensor	C0SNSR04AE1-
----------------------------------	--------------

Accessories For Digital Non-Programmable Thermostats Above

Optional wall mounting plate	C0MISC17AE1-
------------------------------------	--------------

WEIGHT DATA

Model Number	Net		Shipping	
	kg	lbs.	kg	lbs.
090/102 Base Unit	590	1300	628	1385
090/102 Max. Unit	692	1525	730	1610
120 Base Unit	615	1355	653	1440
120 Max. Unit	717	1580	755	1665
150 Base Unit	630	1390	669	1475
150 Max. Unit	733	1615	771	1700

OPTIONS / ACCESSORIES

		Weight	
		kg.	lbs.
CEILING DIFFUSERS			
Step-Down	RTD11-95	40	88
	RTD11-135	93	205
	RTD11-185	178	392
Flush	FD11-95	34	75
	FD11-135	79	174
	FD11-185	131	289
Transitions	LASRT08/10	14	30
	LASRT10/12	15	32
	LASRT15	16	36

ECONOMIZER / OUTDOOR AIR / EXHAUST

Economizer	LAREMD10/15	21	47
Barometric Relief			
Down-Flow Barometric Relief Dampers	LAGED10/15	4	8
Horizontal Barometric Relief Dampers	LAGEDH18/24	9	20
Outdoor Air Dampers			
Damper Section (down-flow) - Automatic	LAOADM10/15	14	31
Damper Section (down-flow) - Manual	LAOAD10/15	12	26
Outdoor Air Hood (down-flow)	LAOAH10/15	5	11
Power Exhaust	LAPEF10/15	13	28

PACKAGING

LTL Packaging (less than truck load)		48	105
--------------------------------------	--	----	-----

ROOF CURBS - STANDARD

Down-Flow			
356 mm height	LARMF10/15-14	57	126
610 mm height	LARMF10/15-24	79	174

ROOF CURBS - CLIPLOCK 1000

Down-Flow			
356 mm height	LARMF10/15S-14	52	115
457 mm height	LARMF10/15S-28	71	156
610 mm height	LARMF10/15S-24	86	189

Base Unit - The unit with low fire heat exchanger NO OPTIONS.

Max. Unit - The unit with ALL OPTIONS Installed. (High Input Heat Exchanger, Economizer, Power Exhaust Fans, Controls)

DIMENSIONS - MM (INCHES)

Model Number	CORNER WEIGHTS								CENTER OF GRAVITY			
	AA		BB		CC		DD		EE		FF	
	kg	lbs.	kg	lbs.	kg	lbs.	kg	lbs.	mm	inch	mm	inch
090/102 Base Unit	142	314	131	289	149	329	167	368	1194	47	546	21-1/2
090/102 Max. Unit	173	381	154	339	170	374	195	431	1168	46	597	23-1/2
120 Base Unit	149	328	136	300	156	343	174	384	1194	47	546	21-1/2
120 Max. Unit	179	394	160	352	176	387	203	447	1168	46	597	23-1/2
150 Base Unit	152	336	152	312	160	353	176	389	1207	47-1/2	559	22
150 Max. Unit	183	403	165	364	181	398	204	450	1181	46-1/2	610	24

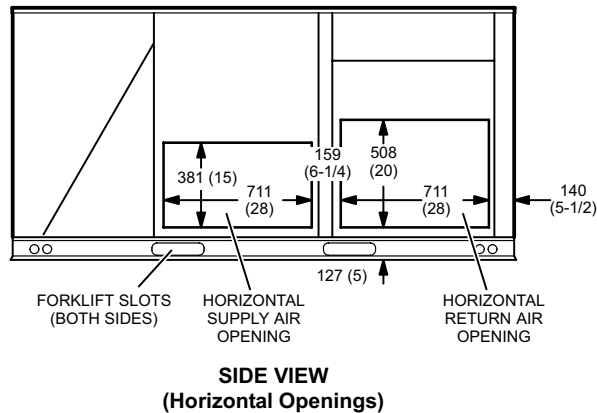
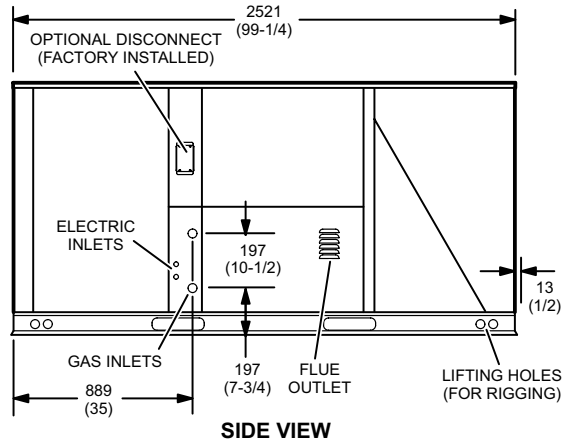
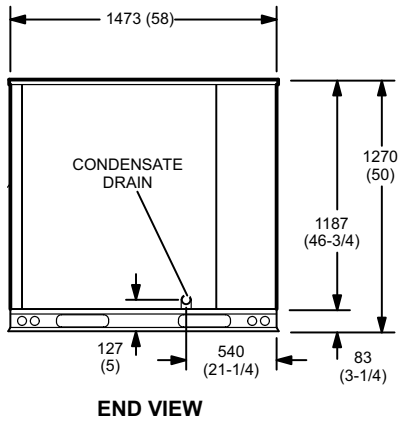
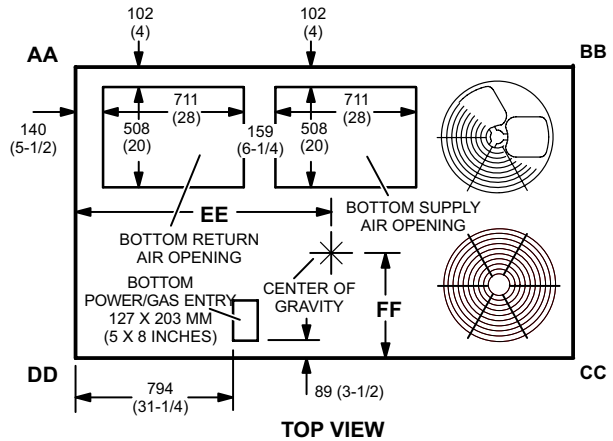

ACCESSORY DIMENSIONS - MM (INCHES)

OPTIONAL OUTDOOR AIR HOOD DETAIL

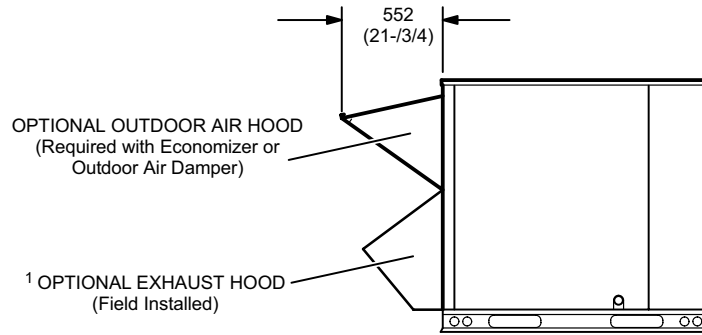

¹ NOTE — Field Installed in Return Air Duct for Horizontal Applications.

HORIZONTAL BAROMETRIC RELIEF DAMPERS (Field installed in horizontal return air duct adjacent to unit)

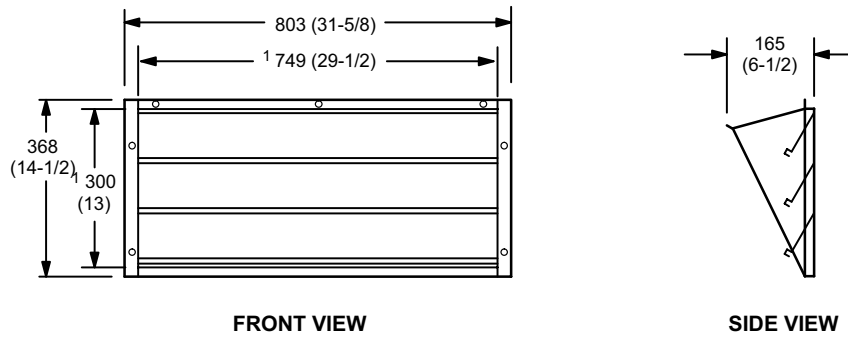

¹ NOTE - Opening size required in return air duct.

ACCESSORY DIMENSIONS - MM (INCHES)

STANDARD ROOF CURBS - DOUBLE DUCT OPENING

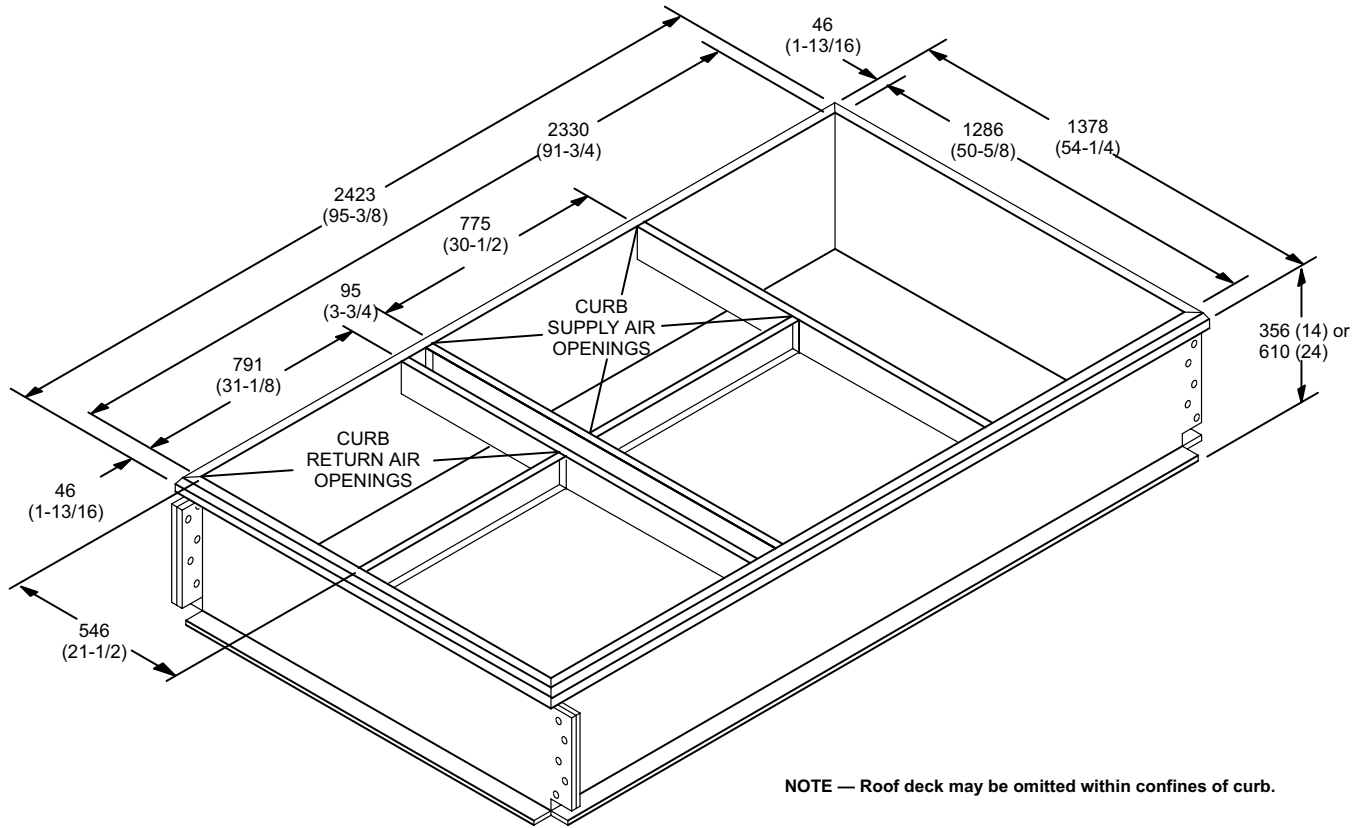

NOTE — Roof deck may be omitted within confines of curb.

TYPICAL FLASHING DETAIL FOR ROOF CURB

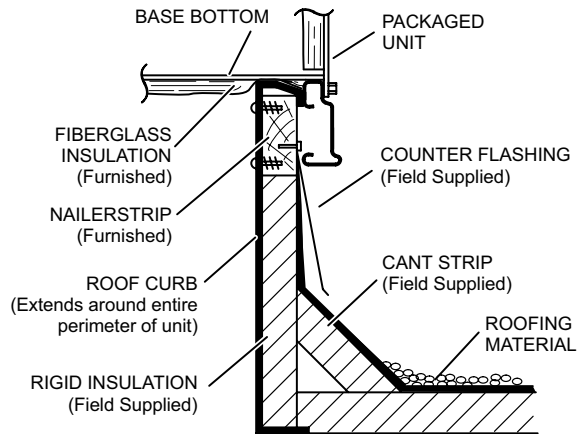

DETAIL ROOF CURB

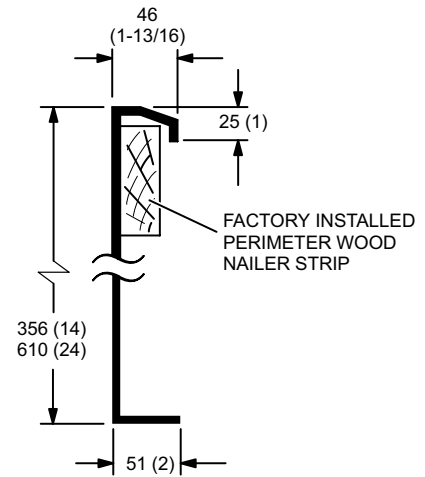

ACCESSORY DIMENSIONS - INCHES (MM)

CLIPLOCK 1000 ROOF CURBS - DOUBLE DUCT OPENING

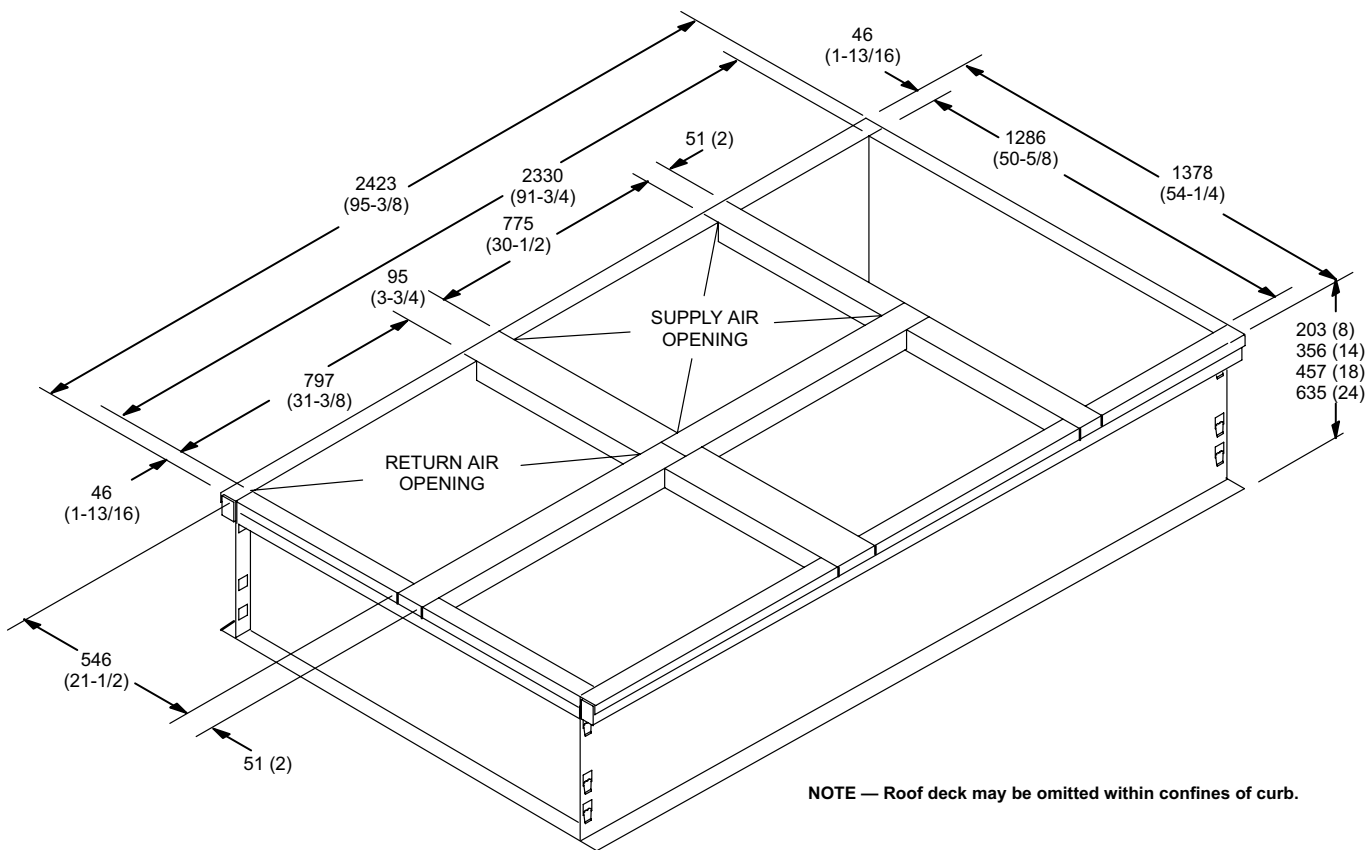

NOTE — Roof deck may be omitted within confines of curb.

TYPICAL FLASHING DETAIL FOR ROOF CURB

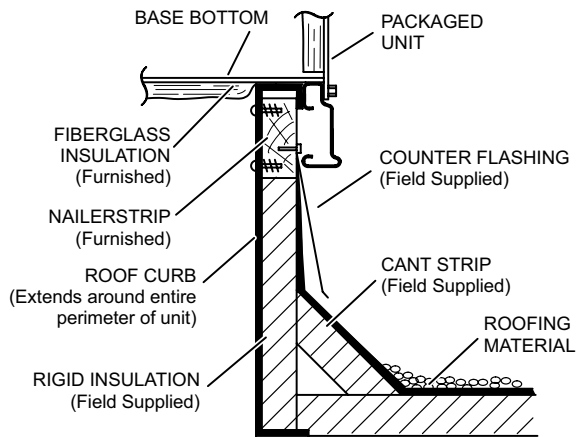

DETAIL ROOF CURB

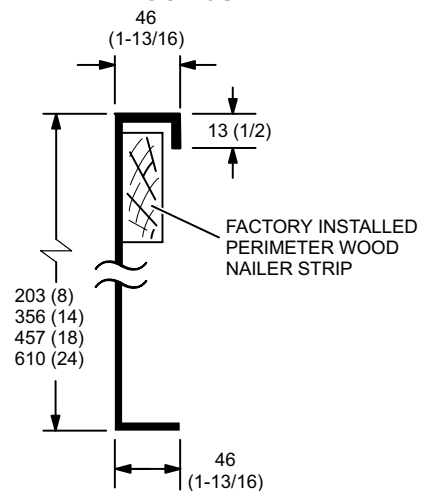

ACCESSORY DIMENSIONS - MM (INCHES)

STANDARD ROOF CURBS WITH SUPPLY & RETURN AIR TRANSITIONS FOR CEILING DIFFUSERS

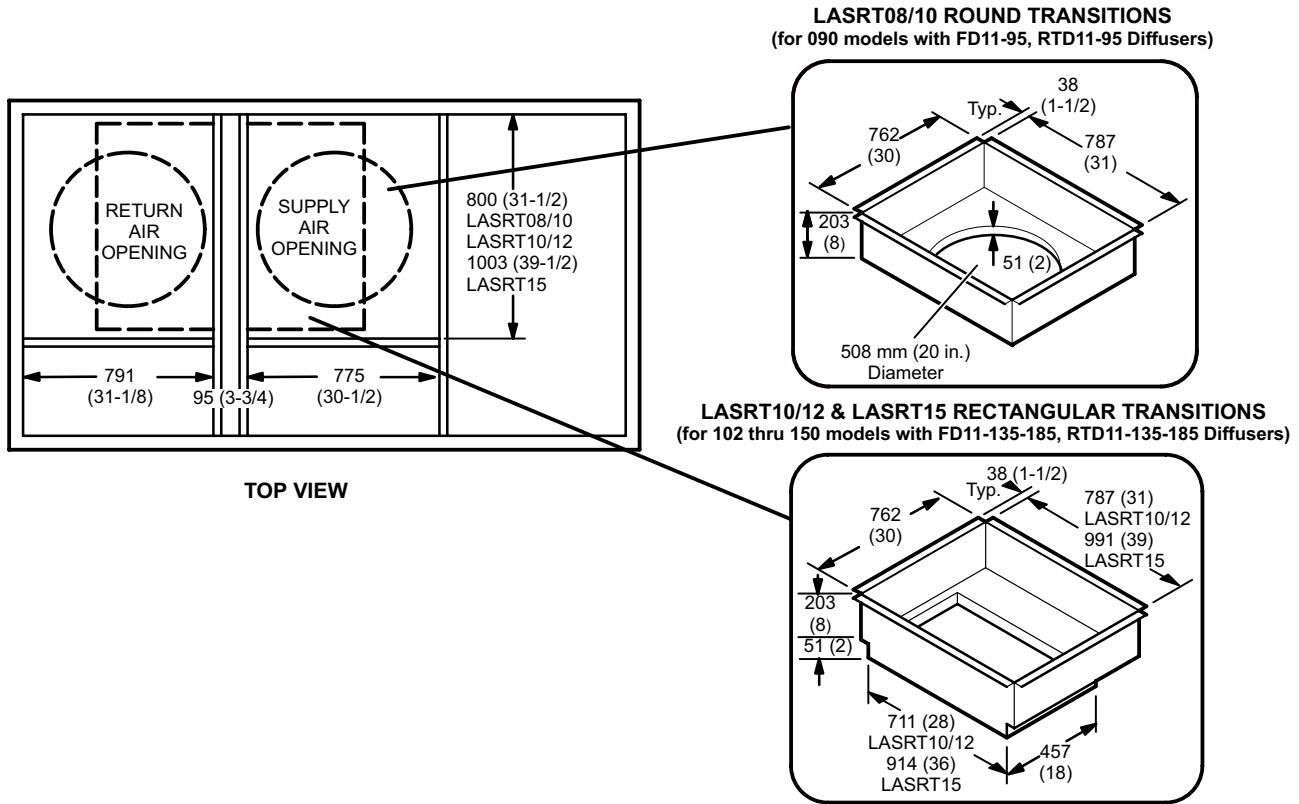

ACCESSORY DIMENSIONS - MM (INCHES)

COMBINATION CEILING SUPPLY AND RETURN DIFFUSERS

STEP-DOWN CEILING DIFFUSER

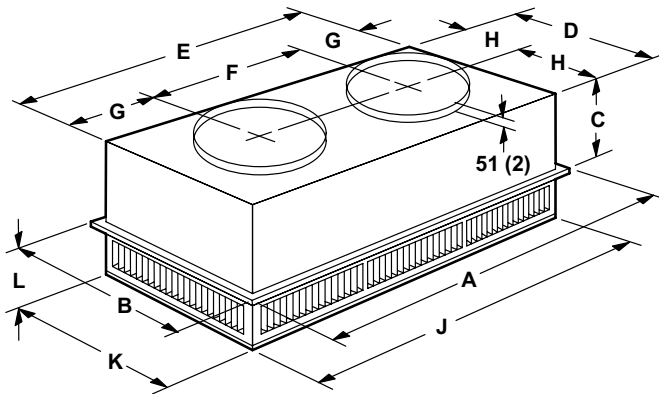

Model Number		RTD11-95
A	mm	1159
	in.	47-5/8
B	mm	752
	in.	29-5/8
C	mm	365
	in.	14-3/8
D	mm	699
	in.	27-1/2
E	mm	1158
	in.	45-1/2
F	mm	572
	in.	22-1/2
G	mm	292
	in.	11-1/2
H	mm	349
	in.	13-3/4
J	mm	1156
	in.	45-1/2
K	mm	699
	in.	27-1/2
L	mm	206
	in.	8-1/8
Duct Size	mm	508 round
	in.	20 round

FLUSH CEILING DIFFUSER

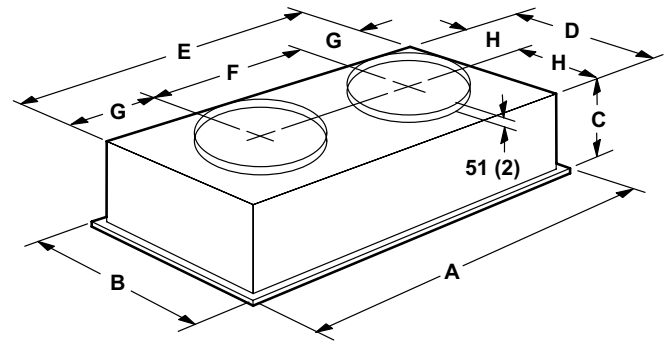

Model Number		FD11-95
A	mm	1159
	in.	47-5/8
B	mm	752
	in.	29-5/8
C	mm	422
	in.	16-5/8
D	mm	686
	in.	27
E	mm	1143
	in.	45
F	mm	572
	in.	22-1/2
G	mm	286
	in.	11-1/4
H	mm	343
	in.	13-1/2
Duct Size	mm	508 round
	in.	20 round

ACCESSORY DIMENSIONS - MM (INCHES)

COMBINATION CEILING SUPPLY AND RETURN DIFFUSERS

STEP-DOWN CEILING DIFFUSER

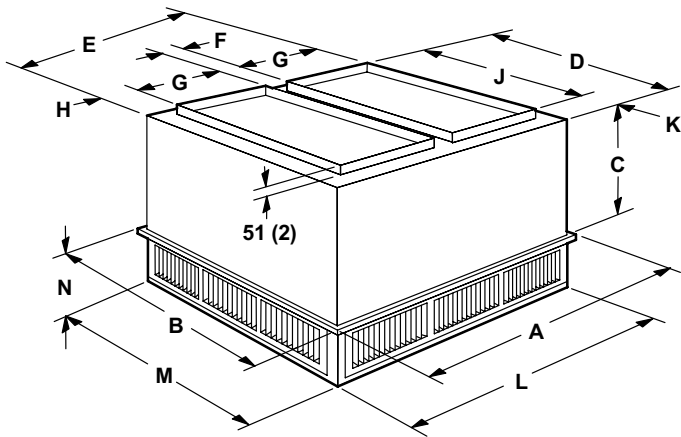

FLUSH CEILING DIFFUSER

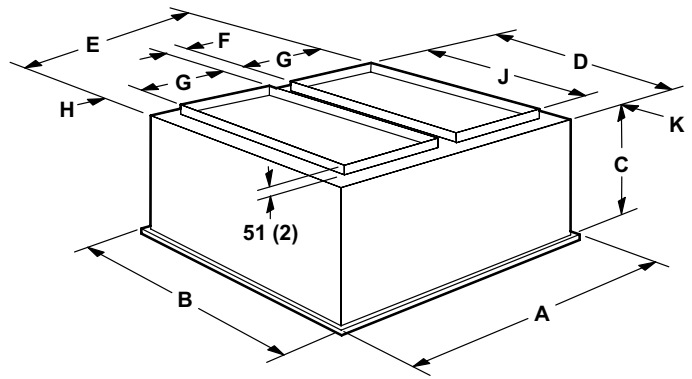

Model Number		RTD11-135	RTD11-185
A	mm	1210	1210
	in.	47-5/8	47-5/8
B	mm	905	1210
	in.	35-5/8	47-5/8
C	mm	524	625
	in.	20-5/8	24-5/8
D	mm	851	1156
	in.	33-1/2	45-1/2
E	mm	1156	1156
	in.	45-1/2	45-1/2
F	mm	114	114
	in.	4-1/2	4-1/2
G	mm	457	457
	in.	18	18
H	mm	64	64
	in.	2-1/2	2-1/2
J	mm	711	914
	in.	28	36
K	mm	70	121
	in.	2-3/4	4-3/4
L	mm	1156	1156
	in.	45-1/2	45-1/2
M	mm	851	1156
	in.	33-1/2	45-1/2
N	mm	232	257
	in.	9-1/8	10-1/8
Duct Size	mm	457 x 711	457 x 914
	in.	18 x 28	18 x 36

Model Number		FD11-135	FD11-185
A	mm	1210	1210
	in.	47-5/8	47-5/8
B	mm	905	1210
	in.	35-5/8	47-5/8
C	mm	591	743
	in.	23-1/4	29-1/4
D	mm	838	1143
	in.	33	45
E	mm	1143	1143
	in.	45	45
F	mm	114	114
	in.	4-1/2	4-1/2
G	mm	457	457
	in.	18	18
H	mm	57	57
	in.	2-1/4	2-1/4
J	mm	711	914
	in.	28	36
K	mm	64	114
	in.	2-1/2	4-1/2
Duct Size	mm	457 x 711	457 x 914
	in.	18 x 28	18 x 36



Visit us at www.lennox.com
For the latest technical information, www.lennoxcommercial.com
Contact us at 1-800-4-LENNOX

