



Nominal Cooling Capacity - 46 to 88 kW
Net Cooling Capacity - 41.1 to 76.2 kW
Gas Input Heat Capacity - 49.5 to 123.0 kW

MODEL NUMBER IDENTIFICATION

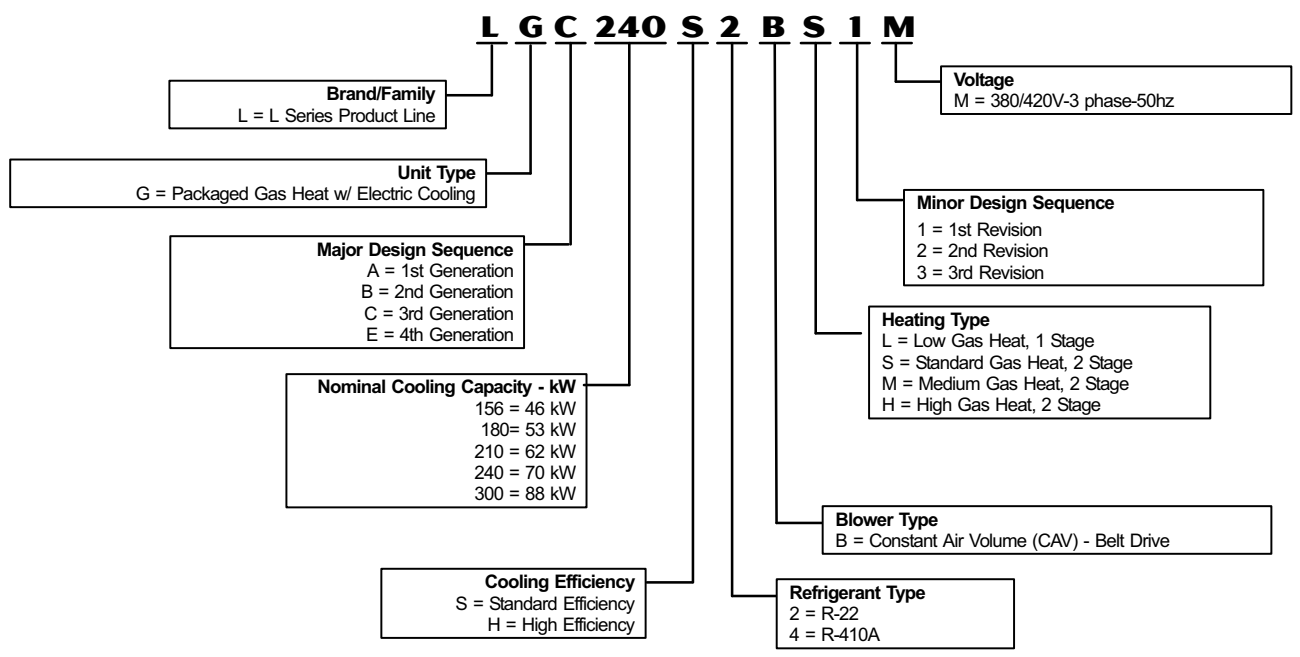

TABLE OF CONTENTS

Blower Data	Pages 22-29
Cooling Ratings	Pages 16-22
Dimensions	Pages 35-41
Electrical / Electric Heat Data	Pages 30-31
Features and Benefits	Pages 2-5
Model Number Identification	Page 1
Options / Accessories	Pages 7-9
Specifications	Pages 10-14
Sound Data	Page 31
Temperature Control Systems	Page 6
Unit Clearances	Page 32
Weight Data	Page 34

FEATURES AND BENEFITS

PERFORMANCE / QUALITY

Components bonded for grounding to meet safety standards for servicing required by Underwriters Laboratories (UL) and the International Electrotechnical Commission (IEC).

Cooling performance is rated at test conditions included in Air-Conditioning and Refrigeration Institute (ARI) Standard 340/360-2004 while operating at rated voltage and air volumes.

International Organization for Standardization (ISO) 9001 Registered Manufacturing Quality System.

COOLING SYSTEM

Designed to maximize sensible and latent cooling performance at design conditions.

Two efficiency levels provide flexibility. System can operate from -17.7°C to 51.6°C (0°F to 125°F) without any additional controls.

1 Compressors

Resiliently mounted on rubber grommets for quiet operation. Scroll compressors on all models for high performance, reliability and quiet operation.

Compressor Crankcase Heaters

Protects against refrigerant migration that can occur during low ambient operation.

2 Thermal Expansion Valves

Assures optimal performance throughout the application range. Removable element head.

3 Filter/Driers

High capacity filter/driers protect the system from dirt and moisture.

4 High Pressure Switches

Protects the compressor from overload conditions such as dirty condenser coils, blocked refrigerant flow, or loss of outdoor fan operation. Automatic reset

Low Pressure Switches

Protects the compressor from low pressure conditions such as low refrigerant charge, or low/no air flow. Automatic reset.

Freezestats

Protects the evaporator coil from damaging ice build-up due to conditions such as low/no air flow, or low/no refrigerant charge.

5 Coil Construction

Copper tube construction, enhanced rippled-edge aluminum fins, flared shoulder tubing connections, silver soldered construction for improved heat transfer. Factory leak tested.

Evaporator Coil

Face-split coil. Cross row circuiting with rifled copper tubing optimizes both sensible and latent cooling capacity. Low fin density minimizes air pressure drop.

Condenser Coil

Angled, slab design helps protect coil from possible contact or hail damage.

Condensate Drain Pan

Drain connection extends outside unit. Painted, galvanized pan with positive slope. Stainless steel drain pan available as a factory installed option.

6 Outdoor Coil Fan Motors

Thermal overload protected, totally enclosed, permanently lubricated ball bearings, shaft up, wire basket mount.

Outdoor Coil Fan

Polyvinyl (PVC) coated fan guard furnished.

Refrigerant Choice

R-22 or R-410A refrigerant.

REQUIRED SELECTIONS

Cooling Capacity

Specify the nominal cooling capacity of the unit.

Cooling Efficiency

Specify either standard or high efficiency.

Refrigerant Choice

Specify R-22 or R-410A refrigerant.

OPTIONS / ACCESSORIES

Factory Installed

Fresh Air Tempering

Provides heating and cooling as needed to maintain the supply air temperature within a comfort range, regardless of the thermostat demand. Sensor ships with unit but must be field installed in the supply air duct. Requires change to IMC (Integrated Modular Control) (ECTO) parameter in the field to activate this mode of operation.

Service Valves

Fully serviceable brass valves installed in discharge & liquid lines.

Stainless Steel Condensate Drain Pan

Factory installed

Factory or Field Installed

Condensate Drain Trap

Field installed only, may be factory enclosed to ship with unit. Available in copper or polyvinyl chloride (PVC).

FEATURES AND BENEFITS

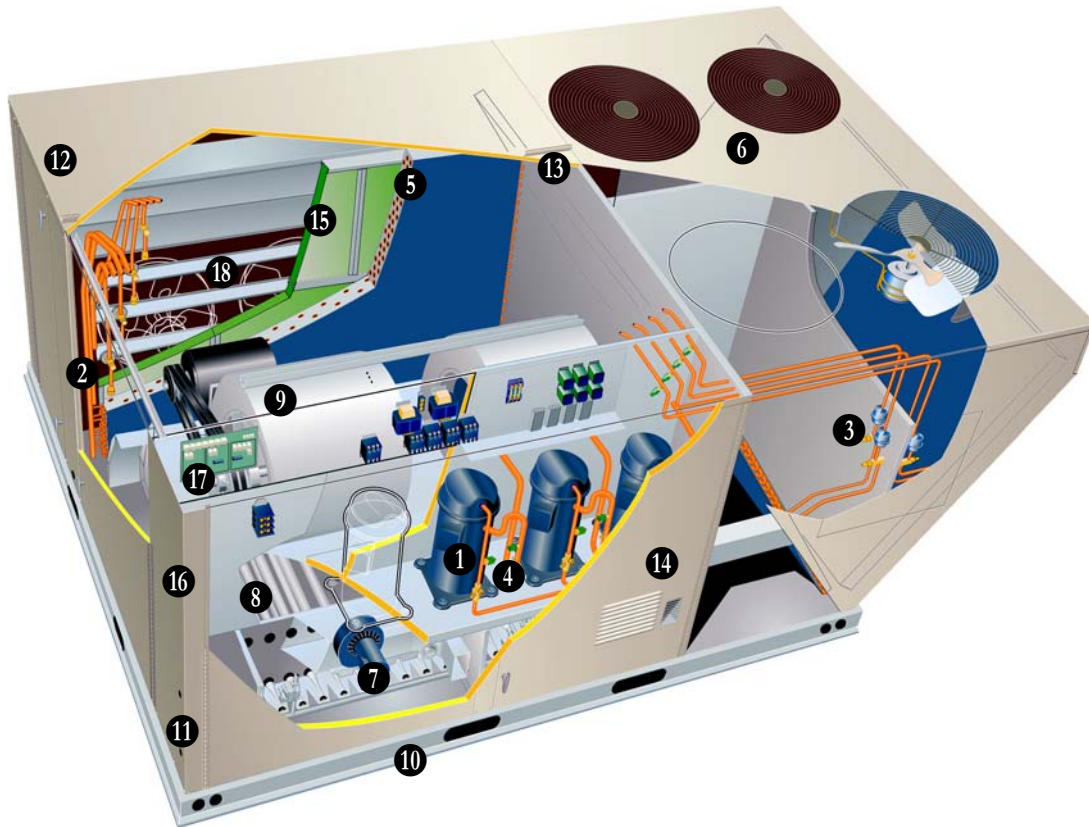

HEATING SYSTEM

7 Aluminized steel inshot burners, direct spark ignition, electronic flame sensor, combustion air inducer, redundant automatic single or dual stage gas valve with manual shut-off.

8 Heat Exchanger

Tubular construction, aluminized steel, life cycle tested. Stainless Steel Heat Exchanger is required if mixed air temperature is less than 7.2°C (45°F).

Fan & Limit Controls

Factory installed with fixed temperature setting. Heat limit controls protect against overheating.

Safety Switches

Flame roll-out switches, flame sensors and combustion air inducer proving switches protect system operation. All safety switches are monitored by the IMC unit controller and diagnostic errors are reported and recorded.

REQUIRED SELECTIONS

Gas Input - Order one:

49.5 kW Low Heat Gas Input (LGC156, LGC180 and LGC210 models only).
49.5 / 68.5 kW low/high fire - Standard Heat Gas Input.
68.5 / 91.9 kW low/high fire - Medium Gas Heat Input.
91.4 / 123.0 kW low/high fire - High Gas Heat Input (Not available for LGC156).

OPTIONS / ACCESSORIES

Factory Installed

Stainless Steel Heat Exchanger

Required if mixed air temperature is below 7.2°C (45°F).

Low Temperature Vestibule Heater

Electric heater automatically controls minimum temperature in gas burner compartment when temperature is below -40°C (-40°F).

Discharge Air Temperature Sensor

Sensor sends information to the IMC to cycle up to 4 stages of heating or cooling to maintain the discharge air setpoints for heating or cooling. Optional sensor is shipped with the unit for remote field installation in the supply duct.

Factory or Field Installed

Field Installed

Combustion Air Intake Extensions

Recommended for use with existing flue extension kits in areas where high snow drifts can block intake air.

Side Gas Piping Kit

Kit allows gas to be brought into the unit from the side. Includes gas shut-off valve and all piping and connections needed.

LPG/Propane Kits

Conversion kit to field change over units from Natural Gas to LPG/Propane.

Vertical Vent Extension Kit

Exhausts flue gases vertically above unit.

9 BLOWER

A wide selection of supply air blower options are available to meet a variety of air flow requirements.

Motor

Overload protected, equipped with ball bearings.

Belt drive motors are offered in several different sizes to maximize air performance.

Motor Efficiency

Specify standard or high.

Supply Air Blower

Forward curved blades, blower wheel is statically and dynamically balanced.

Belt drive motors with adjustable pulley for speed change.

Blower assembly slides out of unit for servicing.

Grease fittings furnished.

REQUIRED SELECTIONS

Supply Air Blower

Order Standard or High Efficiency Blower motor (See Blower Data Table for specifications).

Order one drive kit, see Drive Kit Specifications Table.

FEATURES AND BENEFITS

CABINET

Construction

Heavy-gauge steel panels and full perimeter heavy-gauge galvanized steel base rail provides structural integrity for transportation, handling, and installation.

- 10 Base rails have rigging holes. Three sides of the base rail have fork slots. Raised edges around duct and power entry openings in the bottom of the unit provide additional protection against water entering the building.

Air-Flow Choice

Units are available in down-flow (vertical) or horizontal return air flow configuration.

Horizontal air flow requires Horizontal Roof Curb.

Horizontal Return Air Panel Kit is also required if converting a down-flow configured unit to horizontal air flow.

11 **Power and Gas Entry**

Electrical and gas lines can be brought through the unit base or through horizontal access knock-outs.

12 **Exterior Panels**

Constructed of heavy-gauge, galvanized steel with a two-layer enamel paint finish.

13 **Insulation**

All panels adjacent to conditioned air are fully insulated with non-hygroscopic fiberglass insulation.

Unit base is fully insulated. The insulation also serves as an air seal to the roof curb, eliminating the need to add a seal during installation.

14 **Access Panels**

Hinged access panels are provided for 2 compressor/controls/heating areas, blower access and air filter/economizer access.

All panels have seals and quarter-turn latching handles to provide a tight air and water seal.

REQUIRED SELECTIONS

Air Flow Configuration

Specify horizontal or down-flow.

OPTIONS / ACCESSORIES

Factory Installed

Corrosion Protection

Phenolic epoxy coating, applied to condenser coils (with painted base section) and evaporator coils (with painted base and painted blower housings), factory applied to either section or both sections.

Field Installed

Coil Guards

Painted, galvanized steel wire guards to protect outdoor coil. Not used with Hail Guards.

Grille Guards

Protects the space between outdoor coils and main cabinet.

Hail Guards

Constructed of heavy gauge steel, painted to match cabinet, helps protect outdoor coils from hail damage. Not used with Coil Guards.

Horizontal Return Air Panel Kit

Required for horizontal applications with Horizontal Roof Curb, contains panel with return air opening for field replacement of existing unit panel and panel to cover bottom return air opening in unit, see dimension drawings.

INDOOR AIR QUALITY

15 **Air Filters**

Disposable 51 mm (2 inch) filters furnished as standard.

OPTIONS / ACCESSORIES

Factory or Field Installed

Healthy Climate® High Efficiency Air Filters

Disposable MERV 11 (Minimum Efficiency Reporting Value based on ASHRAE 52.2) efficiency 51 mm (2 inch) pleated filters.

Field Installed

Healthy Climate® High Efficiency Air Filters

Disposable MERV 15 (Minimum Efficiency Reporting Value based on ASHRAE 52.2) efficiency 51 mm (2 inch) pleated filters.

Replacement Filter Media Kit With Frame

Replaces existing pleated filter media. Includes washable metal mesh screen and metal frame with clip for holding replaceable non-pleated filter media. Filter media is furnished.

Indoor Air Quality (CO₂) Sensor

Monitors CO₂ levels, reports to IMC board which adjusts economizer dampers as needed.

ELECTRICAL

OPTIONS/ACCESSORIES

Factory or Field Installed

16 **Disconnect Switch up to 250 Amp**

Accessible from outside of unit, spring loaded weatherproof cover furnished. Main power to the unit is field connected to the disconnect which allows all power to be shut off for service. See Electrical / Electric Heat tables for field installed disconnect switches.

SERVICEABILITY

Designed to streamline general maintenance and decrease troubleshooting time.

Diagnostics

IMC diagnostic codes pinpoint problems, minimizing troubleshooting time.

Marked & Color-Coded Wiring

All electrical wiring is color-coded and marked to identify which components it is connecting.

Electrical Plugs

Positive connection electrical plugs are used to connect common accessories or maintenance parts for easy removal or installation.

Tool-less, Hinged Access Panels

Large access panels are hinged and have quarter-turn, latching handles for quick and easy access to maintenance areas.

Filter access panels are hinged for easy access to the filters.

Blower Access

Blower assembly slides out of the unit for easy access.

Coil Cleaning

Slab condenser coils allow easier cleaning.

Standard Components

A large number of common maintenance parts are standard throughout the entire range of sizes, reducing the need to carry a lot of different parts to the job or in inventory.

Compressor Compartment

Compressors are located near the perimeter of the unit for easier access. Compressors are isolated from the condenser air flow allowing system operation checks to be done without changing the air flow across the outdoor coils.

Thermal Expansion Valves

Thermal expansion valves are located near the perimeter of the unit for easier access.

Removable element head allows change out of element and bulb without removing the TXV.

Service Valves (optional)

Optional factory installed liquid and discharge service valves allow refrigerant to be isolated to the high side for service work on the low side of the refrigeration system.

FEATURES AND BENEFITS

CONTROLS

17 INTELLIGENT UNIT CONTROLLER

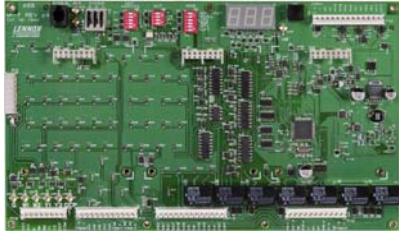

The Integrated Modular Controller (IMC) is a solid-state microprocessor-based control board that provides flexible control of all unit functions.

All control voltage is provided via a 24V (secondary) transformer with built-in circuit breaker protection.

Built-in functions include:

Blower On/Off Delay - Adjustable time delay between blower on and off.

Built-in Control Parameter Defaults - No programming required.

Compressor Time-Off Delay - Adjustable time delay between compressor shutoff and start up.

DDC Compatible - Various third party DDC controllers can be field installed.

Dirty Filter Switch Input - When a Dirty Filter Switch is installed, the IMC will signal when the indoor blower static pressure increases, indicating a dirty filter condition. Switch is optional and can be factory or field installed.

Discharge Air Temperature Control - The IMC will cycle up to 4 stages of heating or cooling to maintain the discharge air setpoints for heating or cooling. Optional sensor is shipped with the unit for remote field installation in the supply duct.

Display/Sensor Readout - Displays control parameters, diagnostic codes, and sensor readings. The IMC unit controller displays temperature readings from return air, supply air, and outdoor air sensors that are furnished as standard on all L Series units. IMC will also display readings from optional sensors such as zone sensors, CO₂ sensors or relative humidity sensors.

Economizer Control Choice - The economizer is controlled by an add-on board to the IMC. The economizer control board has several choices for controlling the economizer. See Economizer / Outdoor Air / Exhaust Options.

Extensive Unit Diagnostics - The IMC monitors all sensors and functions related to unit operation to provide critical information. The IMC will display detailed diagnostic information with over 90 diagnostic codes to pinpoint any problems and reduce troubleshooting time. All diagnostic codes are listed inside control access panel for easy reference.

Exhaust Fan Control Modes - Fans controlled by fresh air damper position or building static differential pressure transducer.

Fresh Air Tempering - Provides heating and cooling as needed to maintain the supply air temperature within a comfort range, regardless of the thermostat demand. Sensor ships with unit but must be field installed in the supply air duct. Requires change to IMC (ECTO) parameter in the field to activate this mode of operation.

Permanent Diagnostic Code Storage - Maintains diagnostic codes through a power failure.

Field Changeable Control Parameters - Over 200 different control parameters allow customization of the unit operation by changing delays, cooling stages, deadbands, and setpoints.

Indoor Air Quality Input - The IMC is Demand Control Ventilation ready from the factory (optional field installed CO₂ sensor required). Two modes of operation are available: setpoint and proportional.

1 - Setpoint - Opens the economizer dampers to full position when CO₂ setpoint level is reached.

2 - Proportional - Opens the dampers at the first set point and gradually increases it as the CO₂ level increases until the second setpoint is reached.

Low Ambient Controls - Allows unit cooling operation down to -17°C (0°F).

Gas Valve Time Delay Between First and Second Stage - Allows gradual increase of input rate.

Minimum Compressor Run Time - Ensures proper oil return to the compressor.

Network Capable - The IMC can be daisy chained to other L Series units or L Connection® Network controllers using twisted pair wire.

Night Setback Mode - Adjusts setpoints, closes outdoor air dampers and operates the blower on demand, may be customized for special requirements.

Return Air Temperature Limit Control - Allows the user to override the demands based upon the return air temperature during either heating or cooling operation. Helps protect against abnormal operating conditions in the event of a room sensor or thermostat failure.

Safety Switch Input - Normally-closed digital input allows the IMC to respond to a external safety switch trip (phase protector, low voltage, etc.) shutting down unit operation.

Service Relay Output - Digital output can indicate a critical error has occurred to an external control device. Can also be configured to energize based on relative humidity, indoor air quality, outdoor air temperature or unit operation.

Smoke Alarm Mode - Control board has four choices for responding to a smoke alarm.

1 - Unit Off - unit will turn off.

2 - Positive Pressure - blower is energized, exhaust fan is

de-energized, and the outdoor air dampers are opened.

3 - Negative Pressure - blower is energized, exhaust fan is energized, and the outdoor air dampers are closed.

4 - Purge - blower is energized, exhaust fan is energized, and the outdoor air dampers are opened.

Staging - 2 heat/2 cool. Capable of up to 4 heat/4 cool with zone sensor or third party DDC control system.

“Strike Three” Protection - Ends cooling or heating operation when any of the following occurs three times (adjustable) within a thermostat cycle: low pressure trip, high pressure trip, heat limit trip, or freeze-stat trip.

Gas Reheat - Control parameter option that allows simultaneous heating and cooling operation for controlling humidity for process air applications such as supermarkets. Field installed relative humidity sensor or dehumidistat can be used.

On-Demand Dehumidification - Prioritizes heat and cool demand with dehumidification demand. Reheat demand can be enabled by digital input or a field installed relative humidity sensor can be used. CAV models only.

Thermostat Bounce Delay - Protects compressor from short cycling when mechanical thermostat is used.

Warm-up Mode Delay - Adjustable time that the economizer dampers are kept in the closed position during morning warm-up.

On-Board User Interface - Push-button, DIP switches used with three-digit display readout for field adjustment of control parameters. LED indicators for each thermostat input.

PC Interface - PC with optional Unit Controller software may be used to field or remotely adjust parameters, read alarms, or display unit status.

Zone Sensor Operation - Controls zone temperature with up to 4 stages of heating or cooling with optional zone sensor.

FEATURES AND BENEFITS

OPTIONS / ACCESSORIES

Factory or Field Installed

Blower Proving Switch

Monitors blower operation, shuts down unit if blower fails. Factory installed.

Dirty Filter Switch

Senses static pressure increase indicating dirty filter condition.

Smoke Detector

Photoelectric type, installed in supply air section or return air section or both sections

Fresh Air Tempering

Provides heating and cooling as needed to maintain the supply air temperature within a comfort range, regardless of the thermostat demand. Sensor ships with unit but must be field installed in the supply air duct. Requires change to IMC (Integrated Control Module) (ECTO) parameter in the field to activate this mode of operation.

Commercial Control Systems

Thermostats

Control system and thermostat options. Aftermarket unit controller options. See Page 6.

Field Installed

Humidity Sensor Kit, Remote Mounted

Humidity sensor required with Supermarket reheat field selectable option.

OPTIONS / ACCESSORIES

ECONOMIZER/OUTDOOR AIR/EXHAUST

Factory or Field Installed

18 Economizer

Parallel gear driven action return air and outdoor air dampers, plug-in connections to unit, nylon bearings, neoprene seals, 24 volt fully modulating spring return motor, adjustable minimum damper position, damper assembly slides in unit, outdoor air hood must be ordered separately, optional down-flow barometric relief dampers available, choice of economizer controls. The IMC add-on board for economizer control is included with the economizer. Control board has four choices for controlling the economizer (DIP switch selections).

1 - Differential Sensible Control -

Factory setting. Uses the outdoor air and return air sensors that are furnished with the unit. The IMC compares the outdoor air and return air and using setpoints, enables the economizer when the outdoor air temperature is below the configured setpoint and cooler than return air.

NOTE - Differential Sensible Control can be configured in the field to provide Offset Differential Sensible Control or Single Sensible Control.

In Offset Differential Sensible Control mode, the economizer is enabled if the temperature differential (offset) between outdoor air and return air reaches the configured setpoint.

In Single Sensible Control mode, the economizer is enabled when outdoor air temperature falls below the configured setpoint.

2 - Global Control - The IMC communicates with a DDC system with one global sensor (enthalpy or sensible) to determine whether outside air is suitable for free cooling on all units connected to the control system. Sensor must be field provided.

3 - Single Enthalpy Control - Outdoor air enthalpy sensor enables economizer if the outdoor enthalpy is less than the setpoint of the board. Factory installed.

4 - Differential Enthalpy Control - Two solid-state enthalpy sensors allow the economizer control board to select between outdoor air or return air, whichever has lower enthalpy. Factory installed.

Outdoor Air Dampers, Manual or Motorized

Linked mechanical dampers, 0 to 25% (fixed) outdoor air adjustable, installs in unit, outdoor air hood must be ordered separately. Motorized model features fully modulating spring return damper motor with plug-in connection. Manual model features a slide damper.

Outdoor Air Hood

Required with LAREMD Economizer, LAOAD and LAOADM Outdoor Air Damper Sections, cleanable aluminum mesh fresh air filters furnished.

Down-Flow Barometric Relief Dampers

Allows relief of excess air, aluminum blade dampers prevent blow back and outdoor air infiltration during off cycle, bird screen furnished. Dampers are required with Power Exhaust Fans. Down-Flow Barometric Relief Damper Hood is available and must be ordered extra.

Factory or Field Installed

Standard Static Power Exhaust Fans

Two, 250 Watt (1/3 hp) motors with 508 mm (20 in.), five blade propeller-type fans with a total power input of 750 Watts and a total air volume of 4070 L/s (8630 cfm) at 0 Pa (0 in. w.g.).

Motor is inherently protected and enclosed for maximum protection from weather, dust and corrosion. Installs internal to unit for down-flow applications only with economizer option, provides exhaust air pressure relief, interlocked to run when return air dampers are closed and supply air blower is operating, fan runs when outdoor air dampers are 50% open (adjustable), motor is overload protected, steel cabinet and hood painted to match unit, requires optional Down-flow Economizer Barometric Relief Dampers.

See Standard Static Power Exhaust Blower Tables.

Power Exhaust Control Options:

Damper Position Control

IMC controls exhaust fan based on economizer damper position.

Field Installed

Down-Flow Barometric Relief Damper Hood

Field installed only. Use with Barometric Relief Dampers.

Horizontal Barometric Relief Dampers

Aluminum blade dampers prevent blow back and outdoor air infiltration during off cycle, field installed in return air duct, bird screen furnished.

CEILING DIFFUSERS

Field Installed

Ceiling Diffusers (Flush or Step-Down)

Aluminum grilles, large center grille, insulated diffuser box with flanges, hanging rings furnished, interior transition (even air flow), internally sealed (prevents recirculation), adapts to T-bar ceiling grids or plaster ceilings.

Transitions (Supply and Return)

Used with diffusers, installs in roof curb, galvanized steel construction, flanges furnished for duct connection to diffusers, fully insulated.

ROOF CURBS

Field Installed

Nailer strip furnished, mates to unit, shipped knocked down.

Standard roof curb corners fasten together with furnished hardware.

Cliplock curbs use interlocking tabs to fasten together. No tools required.

Standard Down-Flow

US National Roofing Contractors Approved, available in 356 and 610 mm (14 and 24 inch) heights.

Horizontal

Converts unit from down-flow to horizontal (side) air flow, return air is on unit, supply air is on curb, see dimension drawings. Curbs for rooftop applications meet National Roofing Code requirements. Requires Horizontal Return Air Panel. Available in 660, 762, 940, and 1041 mm (26, 30, 37 and 41 inch) heights. Optional Insulation Kit is available to help prevent sweating.

Cliplock 1000 Full Perimeter Down-Flow

Available in 203, 356, 457, and 610 mm (8, 14, 18, and 24 inch) heights.

OPTIONS / ACCESSORIES

Item	Catalog No.	156	180	210	240	300S
COOLING SYSTEM						
Condensate Drain Trap	Polyvinyl Chloride (PVC) - LTACDKP09/36	76M18	⊗	⊗	⊗	⊗
	Copper - LTACDKC09/36	76M19	⊗	⊗	⊗	⊗
Corrosion Protection	Factory	○	○	○	○	○
Efficiency	Standard	Factory		○	○	○
	High	Factory	○	○	○	○
Refrigerant Type	R-22	Factory	○	○	○	○
	R-410A	Factory	○	○	○	○
Service Valves	Factory	○	○	○	○	○
Stainless Steel Condensate Drain Pan	Factory	○	○	○	○	○
HEATING SYSTEM						
Combustion Air Intake Extensions	LTACAIK10/15	89L97	1x	1x	1x	1x
Gas Heat Input	Low - 49.5 kW input	Factory	○	○	○	
	Standard - 66.5 kW input	Factory	○	○	○	○
	Medium - 92.2 kW input	Factory	○	○	○	○
	High - 123.0 kW input	Factory		○	○	○
Low Temperature Vestibule Heater		Factory	○	○	○	○
LPG/Propane Conversion Kits	49.5 kW input - LTALPGK-130	72M94	1x	1x	1x	
	66.5 kW input - LTALPGK-130	72M94	1x	1x	1x	1x
	92.2 kW input - LTALPGK-180	72M95	1x	1x	1x	1x
	123.0 kW input - LTALPGK-240	72M96		1x	1x	1x
Side Gas Piping Kit	C1GPKT01C-	85M31	x	x	x	x
Stainless Steel Heat Exchanger		Factory	○	○	○	○
Vertical Vent Extension	LTAWEK10/15	73M72	1x	1x	1x	1x
BLOWER - SUPPLY AIR						
Constant Air Volume	1.5 kW (2 hp) Standard Efficiency	Factory	○			
	2.2 kW (3 hp) Standard Efficiency	Factory	○	○	○	
	3.7 kW (5 hp) Standard Efficiency	Factory	○	○	○	○
	5.6 kW (7.5 hp) Standard Efficiency	Factory		○	○	○
	7.5 kW (10 hp) Standard Efficiency	Factory				○
CABINET						
Coil Guards		88K52	x	x	x	x
Grille Guards		72K78	x	x	x	x
Hail Guards		88K25	x	x	x	x
Horizontal Return Air Panel Kit		87M00	x	x	x	x
CONTROLS						
Blower Proving Switch	C0SWCH01AE1-	30K49	⊗	⊗	⊗	⊗
Dirty Filter Switch	C0SWCH00AE1-	30K48	⊗	⊗	⊗	⊗
Fresh Air Tempering	C0SNDC03AE1-	45L78	⊗	⊗	⊗	⊗
Smoke Detector - Supply	LTSASDK10/36	70K87	⊗	⊗	⊗	⊗
Smoke Detector - Return	LTARSDK10/30	70K86	⊗	⊗	⊗	⊗

NOTE - The catalog and model numbers that appear here are for ordering field installed accessories only.

⊗ - Field Installed or Configure to Order (factory installed)

○ - Configure to Order (Factory Installed)

X - Field Installed.

OPTIONS / ACCESSORIES

Item	Catalog No.	156	180	210	240	300S
INDOOR AIR QUALITY						
Air Filters						
Healthy Climate® High Efficiency Air Filters 610 x 610 x 51 mm (24 x 24 x 2 in.) - order 6 per unit	MERV 11 - C1FLTR10C-1-	97L87	⊗	⊗	⊗	⊗
	MERV 15 - C1FLTR50C-1-	28W05	x	x	x	x
Replaceable Media Filter With Metal Mesh Frame (includes non-pleated filter media)	C1FLTR30C - order 6 per unit 610 x 610 x 51 mm (24 x 24 x 2 in)	44N61	x	x	x	x
Indoor Air Quality Sensors						
CO ₂ Sensor - white case w/ display	C0SNSR50AE1L	77N39	x	x	x	x
CO ₂ Sensor - white case, no display	C0SNSR52AE1L	87N53	x	x	x	x
CO ₂ Sensor - black case w/ display	C0SNSR51AE1L	87N52	x	x	x	x
CO ₂ Sensor - black case, no display	C0SNSR53AE1L	87N54	x	x	x	x
CO ₂ Sensor Duct Mounting Kit	C0MISC19AE1-	85L43	x	x	x	x
Aspiration Box for duct mounting Sensor	C0MISC16AE1-	90N43	x	x	x	x
Handheld CO ₂ Monitor	LTAIAQSHM03/36	70N93	x	x	x	x
ELECTRICAL						
Voltage - 50 hz with neutral	380/420V - 3 phase	Factory	○	○	○	○
Disconnect Switch - See Electrical / Electric Heat Tables for selection	80 Amp	84M13	⊗	⊗	⊗	⊗
	150 Amp	84M14	⊗	⊗	⊗	⊗
	250 Amp	84M15	⊗	⊗	⊗	⊗
ECONOMIZER						
Economizer - Order Hood Separately	LAREMD18/24	16K95	⊗	⊗	⊗	⊗
Outdoor Air Hood (down-flow) Number of Filters - 406 x 635 x 25 mm (16 x 25 x 1 in.)	C1HOOD10C (3)	85M25	⊗	⊗	⊗	⊗
Economizer Controls						
Differential Enthalpy	C1SNSR07AE1	86M33	⊗	⊗	⊗	⊗
Single Enthalpy	C1SNSR06AE1	86M32	⊗	⊗	⊗	⊗
Global, Enthalpy	Sensor Field Provided	Factory	○	○	○	○
Differential Sensible	Furnished	Factory	○	○	○	○
Barometric Relief						
Down-Flow Barometric Relief Dampers Order Hood Separately	LAGED18/24	16K98	⊗	⊗	⊗	⊗
Hood for Down-Flow LAGED	C1HOOD20C-1	85M26	⊗	⊗	⊗	⊗
Horizontal Barometric Relief Dampers Hood Furnished	LAGEDH18/24	16K99	⊗	⊗	⊗	⊗
OUTDOOR AIR						
Outdoor Air Dampers						
Damper Section (down-flow) - Order Hood Separately	Motorized - LAOADM18/24	16K94	⊗	⊗	⊗	⊗
	Manual - LAOAD18/24	16K93	⊗	⊗	⊗	⊗
Outdoor Air Hood (down-flow) - Number of Filters - 406 x 635 x 25 mm (16 x 25 x 1 in.)	C1HOOD10C-1 (3)	85M25	⊗	⊗	⊗	⊗
Power Exhaust						
Standard Static	380/420V - C1PWRE20C-1M	85M40	⊗	⊗	⊗	⊗

NOTE - The catalog and model numbers that appear here are for ordering field installed accessories only.

⊗ - Field Installed or Configure to Order (factory installed)

○ - Configure to Order (Factory Installed)

x - Field Installed.

OPTIONS / ACCESSORIES

Item	Catalog No.	156	180	210	240	300S
ROOF CURBS - CLIPLOCK 1000						
Down-Flow						
203 mm (8 in.) height	C1CURB40CD1	26W32	x	x	x	x
356 mm (14 in.) height	LARMF18/30S-14	33K44	x	x	x	x
457 mm (18 in.) height	LARMF18/30S-18	33K45	x	x	x	x
610 mm (24 in.) height	LARMF18/30S-24	33K46	x	x	x	x
ROOF CURBS - STANDARD						
Down-Flow						
356 mm (14 in.) height	LARMF18/36-14	16K87	x	x	x	x
610 mm (24 in.) height	LARMF18/36-24	16K88	x	x	x	x
Horizontal						
660 mm (26 in.) height - Rooftop Applications	LARMFH18/24-26	97J33	x	x	x	
940 mm (37 in.) height - Slab Applications	LARMFH18/24-37	38K53	x	x	x	
762 mm (30 in.) height - Rooftop applications	LARMFH30/36-30	33K79				x
1041 mm (41 in.) height - Slab applications	LARMFH30/36-41	38K54				x
Horizontal Air Panel Kit	C1HAP10C-1	87M00	x	x	x	x
Insulation Kits						
for LARMFH18/24-26	C1INSU11C-1	73K32	x	x	x	
for LARMFH18/24-37	C1INSU13C-1	73K34	x	x	x	
for LARMFH30/36-30		73K33				x
for LARMFH30/36-41		73K35				x
CEILING DIFFUSERS						
Step-Down - Order one	RTD11-185	29G06	x	x		
	RTD11-275-R	29G07			x	x
Flush - Order one	FD11-185	29G10	x	x		
	FD11-275-R	29G11			x	x
Transitions (Supply and Return) - Order one	LASRT18	19K01	x	x		
	LASRT21/24	19K02			x	x

NOTE - The catalog and model numbers that appear here are for ordering field installed accessories only.
X - Field Installed.

SPECIFICATIONS

General Data		Nominal Size Model No. Efficiency Type	46 kW		
			LGC156H2B High		LGC156H4B High
Cooling Performance	Gross Cooling Capacity - kW (Btuh)		42.4 (144 900)		42.4 (144 900)
	¹ Net Cooling Capacity - kW (Btuh)		41.1 (140 300)		41.1 (140 300)
	ARI Rated Air Flow - L/s (cfm)		2405 (5100)		2455 (5200)
	Total Unit Power (kW)		11.5		11.5
	¹ EER (Btuh/Watt)		12.2		12.2
	² Integrated Part Load Value (Btuh/Watt)		13.3		13.3
Refrigerant Type			R-22		R-410
Refrigerant Charge Furnished	Circuit 1		4.99 kg (11 lbs. 0 oz.)		5.9 kg (13 lbs. 0 oz.)
	Circuit 2		4.99 kg (11 lbs. 0 oz.)		5.9 kg (13 lbs. 0 oz.)
	Circuit 3		4.99 kg (11 lbs. 0 oz.)		5.9 kg (13 lbs. 0 oz.)
Gas Heating Options Available - See page 15			Low (1 Stage), Standard (2 Stage), or Medium (2 Stage)		
Compressor Type (no.)			Scroll (3)		Scroll (3)
Outdoor Coils	Net face area - m ² (sq. ft.) total		5.25 (56.5)		5.25 (56.5)
	Tube diameter - mm (in.) - No. of rows		9.5 (3/8) - 2		9.5 (3/8) - 2
	Fins per meter (inch)		787 (20)		787 (20)
Outdoor Coil Fans	Motor Watts (horsepower)		(4) 249 (1/3)		(4) 249 (1/3)
	Motor rev/min		896		896
	Total Motor watts		1065		1065
	Diameter - mm (in.) - No. of blades		(4) 610 (24) - 3		(4) 610 (24) - 3
	Total Air volume - L/s (cfm)		6075 (12 900)		6075 (12 900)
Indoor Coils	Net face area - m ² (sq. ft.) total		2.07 (22.3)		2.07 (22.3)
	Tube diameter - mm (in.) - No. of rows		9.5 (3/8) - 3		9.5 (3/8) - 3
	Fins per meter (inch)		551 (14)		551 (14)
	Drain connection - number and size		(1) 1 in. NPT coupling		
Expansion device type			Balanced Port Thermostatic Expansion Valve, removeable power head		
³ Indoor Blower and Drive Selection	Nominal motor output		1.5 kW (2 hp)	2.2 kW (3 hp)	3.7 kW (5 hp)
	Maximum usable motor output		1.7 kW (2.3 hp)	2.6 kW (3.45 hp)	4.3 kW (5.75 hp)
	Motor - Drive kit		1.5 kW kit #A - 446-604 rev/min	2.2 kW kit #2 - 571-721 rev/min	3.7 kW kit #2 - 571-721 rev/min kit #3 - 708-871 rev/min kit #4 - 788-988 rev/min
Blower wheel nominal diameter x width - mm (in.)			(2) 381 x 381 (15 x 15)		
Filters	Type of filter		Disposable		
	No. and size - mm (in.)		(6) 610 x 610 x 51 (24 x 24 x 2)		
Electrical characteristics			380/420V - 50 hertz - 3 phase		

NOTE - Net capacity includes evaporator blower motor heat deduction. Gross capacity does not include evaporator blower motor heat deduction.

¹ Rating test conditions are those included in Air-Conditioning and Refrigeration Institute (ARI) Standard 340/360 while operating at rated voltage and air volumes; 35°C (95°F) outdoor air temperature and 27°C (80°F) db/19°C (67°F) wb entering evaporator air; minimum external duct static pressure.

² Integrated Part Load Value rated at 27°C (80°F) outdoor air temperature.

³ Using total air volume and system static pressure requirements determine from blower performance tables rev/min and motor output required. Maximum usable output of motors furnished are shown. If motors of comparable output are used, be sure to keep within the service factor limitations outlined on the motor nameplate.

SPECIFICATIONS

General Data		Nominal Size	53 kW		
		Model No.	LGC180S2B	LGC180H2B	LGC180H4B
		Efficiency Type	Standard	High	High
Cooling Performance	Gross Cooling Capacity - kW (Btuh)		49.7 (169 700)	49.8 (170 100)	49.7 (169 800)
	¹ Net Cooling Capacity - kW (Btuh)		47.9 (163 600)	48.0 (164 000)	47.9 (163 600)
	ARI Rated Air Flow - L/s (cfm)		2830 (6000)	2690 (5700)	2690 (5700)
	Total Unit Power (kW)		15.7	14.3	14.2
	¹ EER (Btuh/Watt)		10.4	11.5	11.5
	² Integrated Part Load Value (Btuh/Watt)		11.3	12.9	12.9
	Refrigerant Type		R-22	R-22	R-410A
Refrigerant Charge Furnished	Circuit 1		4.08 kg (9 lbs. 0 oz.)	5.22 kg (11 lbs. 8 oz.)	5.22 kg (11 lbs. 8 oz.)
	Circuit 2		4.08 kg (9 lbs. 0 oz.)	5.22 kg (11 lbs. 8 oz.)	5.22 kg (11 lbs. 8 oz.)
	Circuit 3		4.08 kg (9 lbs. 0 oz.)	5.22 kg (11 lbs. 8 oz.)	5.22 kg (11 lbs. 8 oz.)
Gas Heating Options Available - See page 15			Low (1 Stage), Standard (2 Stage), Medium (2 Stage), or High (2 Stage)		
Compressor Type (no.)			Scroll (3)	Scroll (3)	Scroll (3)
Outdoor Coils	Net face area - m ² (sq. ft.) total		5.25 (56.5)	5.25 (56.5)	5.25 (56.5)
	Tube diameter - mm (in.) - No. of rows		9.5 (3/8) - 1	9.5 (3/8) - 2	9.5 (3/8) - 2
	Fins per meter (inch)		787 (20)	787 (20)	787 (20)
Outdoor Coil Fans	Motor Watts (horsepower)		(4) 249 (1/3)	(4) 249 (1/3)	(4) 249 (1/3)
	Motor rev/min		896	896	896
	Total Motor watts		1045	1065	1065
	Diameter - mm (in.) - No. of blades		(4) 610 (24) - 3	(4) 610 (24) - 3	(4) 610 (24) - 3
	Total Air volume - L/s (cfm)		6235 (13 200)	6075 (12 900)	6075 (12 900)
Indoor Coils	Net face area - m ² (sq. ft.) total		2.07 (22.3)	2.07 (22.3)	2.07 (22.3)
	Tube diameter - mm (in.) - No. of rows		9.5 (3/8) - 3	9.5 (3/8) - 3	9.5 (3/8) - 3
	Fins per meter (inch)		551 (14)	551 (14)	551 (14)
	Drain connection - number and size		(1) 1 in. NPT coupling		
Expansion device type			Balanced Port Thermostatic Expansion Valve, removeable power head		
³ Indoor Blower and Drive Selection	Nominal motor output		2.2 kW (3 hp)	3.7 kW (5 hp)	5.6 kW (7.5 hp)
	Maximum usable motor output		2.6 kW (3.45 hp)	4.3 kW (5.75 hp)	6.4 kW (8.63 hp)
	Motor - Drive kit		2.2 kW kit #2 - 571 - 721 rev/min	3.7 kW kit #2 - 571 - 721 rev/min kit #3 - 708 - 871 rev/min kit #4 - 788 - 988 rev/min	5.6 kW kit# 5 - 788 - 988 rev/min kit# 6 - 871 - 1071 rev/min kit# 7 - 708 - 871 rev/min
Blower wheel nominal diameter x width - mm (in.)			(2) 381 x 381 (15 x 15 in.)		
Filters	Type of filter		Disposable		
	No. and size - mm (in.)		(6) 610 x 610 x51 (24 x 24 x 2)		
Electrical characteristics			380/420V - 50 hertz - 3 phase		

NOTE - Net capacity includes evaporator blower motor heat deduction. Gross capacity does not include evaporator blower motor heat deduction.

¹ Rating test conditions are those included in Air-Conditioning and Refrigeration Institute (ARI) Standard 340/360 while operating at rated voltage and air volumes; 35°C (95°F) outdoor air temperature and 27°C (80°F) db/19°C (67°F) wb entering evaporator air; minimum external duct static pressure.

² Integrated Part Load Value tested at 27°C (80°F) outdoor air temperature.

³ Using total air volume and system static pressure requirements determine from blower performance tables rev/min and motor output required. Maximum usable output of motors furnished are shown. If motors of comparable output are used, be sure to keep within the service factor limitations outlined on the motor nameplate.

SPECIFICATIONS

General Data		Nominal Size	62 kW		
		Model No.	LGC210S2B	LGC210H2B	LGC210H4B
		Efficiency Type	Standard	High	High
Cooling Performance	Gross Cooling Capacity - kW (Btuh)		56.4 (192 500)	56.0 (191 400)	56.5 (193 000)
	¹ Net Cooling Capacity - kW (Btuh)		54.0 (184 300)	53.6 (183 200)	54.1 (184 800)
	ARI Rated Air Flow - L/s (cfm)		3210 (6800)	3115 (6600)	3115 (6600)
	Total Unit Power (kW)		17.9	15.9	16.1
	¹ EER (Btuh/Watt)		10.3	11.5	11.5
	² Integrated Part Load Value (Btuh/Watt)		10.8	12.3	12.3
	Refrigerant Type		R-22	R-22	R-410A
Refrigerant Charge Furnished	Circuit 1		3.18 kg (7 lbs. 0 oz.)	4.99 kg (11 lbs. 0 oz.)	5.67 kg (12 lbs. 8 oz.)
	Circuit 2		3.18 kg (7 lbs. 0 oz.)	4.99 kg (11 lbs. 0 oz.)	5.67 kg (12 lbs. 8 oz.)
	Circuit 3		3.18 kg (7 lbs. 0 oz.)	4.99 kg (11 lbs. 0 oz.)	5.44 kg (12 lbs. 0 oz.)
	Circuit 4		3.18 kg (7 lbs. 0 oz.)	4.99 kg (11 lbs. 0 oz.)	5.44 kg (12 lbs. 0 oz.)
Gas Heating Options Available - See page 15			Low (1 Stage), Standard (2 Stage), Medium (2 Stage), or High (2 Stage)		
Compressor Type (no.)			Scroll (4)	Scroll (4)	Scroll (4)
Outdoor Coils	Net face area - m ² (sq. ft.) total		5.25 (56.5)	5.25 (56.5)	5.25 (56.5)
	Tube diameter - mm (in.)		9.5 (3/8)	9.5 (3/8)	9.5 (3/8)
	Number of rows		1	2	2
	Fins per meter (inch)		787 (20)	787 (20)	787 (20)
Outdoor Coil Fans	Motor Watts (horsepower)		(4) 249 (1/3)	(4) 249 (1/3)	(4) 249 (1/3)
	Motor rev/min		896	896	896
	Total Motor watts		1045	1065	1065
	Diameter - mm (in.)		(4) 610 (24)	(4) 610 (24)	(4) 610 (24)
	No. of blades		3	3	3
	Total Air volume - L/s (cfm)		6235 (13 200)	6075 (12 900)	6075 (12 900)
Indoor Coils	Net face area - m ² (sq. ft.) total		2.07 (22.3)	2.07 (22.3)	2.07 (22.3)
	Tube diameter - mm (in.)		9.5 (3/8)	9.5 (3/8)	9.5 (3/8)
	No. of rows		3	4	4
	Fins per meter (inch)		551 (14)	551 (14)	551 (14)
Drain connection - number and size			(1) 1 in. NPT coupling		
Expansion device type			Balanced Port Thermostatic Expansion Valve, removeable power head		
³ Indoor Blower and Drive Selection	Nominal motor output		2.2 kW (3 hp)	3.7 kW (5 hp)	5.6 kW (7.5 hp)
	Maximum usable motor output		2.6 kW (3.45 hp)	4.3 kW (5.75 hp)	6.4 kW (8.63 hp)
	Motor - Drive kit number		2.2 kW kit #2 - 571-721 rev/min	3.7 kW kit #2 - 571 -721 rev/min kit #3 - 708 - 871 rev/min kit #4 - 788 - 988 rev/min	5.6 kW kit# 5 - 788 - 988 rev/min kit# 6 - 871 -1071 rev/min kit# 7 - 708 - 871 rev/min
Blower wheel nominal diameter x width - mm (in.)			(2) 381 x 381 (15 x 15)		
Filters	Type of filter		Disposable		
	No. and size - mm (in.)		(6) 610 x 610 x 51 (24 x 24 x 2)		
Electrical characteristics			380/420V - 50 hertz - 3 phase		

NOTE - Net capacity includes evaporator blower motor heat deduction. Gross capacity does not include evaporator blower motor heat deduction.

¹ Rating test conditions are those included in Air-Conditioning and Refrigeration Institute (ARI) Standard 340/360 while operating at rated voltage and air volumes; 35°C (95°F) outdoor air temperature and 27°C (80°F) db/19°C (67°F) wb entering evaporator air; minimum external duct static pressure.

² Integrated Part Load Value tested at 27°C (80°F) outdoor air temperature.

³ Using total air volume and system static pressure requirements determine from blower performance tables rev/min and motor output required. Maximum usable output of motors furnished are shown. If motors of comparable output are used, be sure to keep within the service factor limitations outlined on the motor nameplate.

SPECIFICATIONS

General Data		Nominal size	70 kW		
		Model No.	LGC240S2B	LGA240H2B	LGA240H4B
		Efficiency Type	Standard	High	High
Cooling Performance	Gross Cooling Capacity - kW (Btuh)		64.8 (221 400)	66.4 (226 700)	63.7 (217 600)
	¹ Net Cooling Capacity - kW (Btuh)		61.7 (210 800)	63.5 (216 800)	60.8 (207 700)
	ARI Rated Air Flow - L/s (cfm)		3775 (8000)	3540 (7500)	3540 (7500)
	Total Unit Power (kW)		21.1	20.1	18.9
	¹ EER (Btuh/Watt)		10.0	10.8	11.0
	² Integrated Part Load Value (Btuh/Watt)		10.3	11.5	12.0
	Refrigerant Type		R-22	R-22	R-410A
Refrigerant Charge Furnished	Circuit 1		4.99 kg (11 lbs. 0 oz.)	510 kg (11 lbs. 4 oz.)	4.76 kg (10 lbs. 8 oz.)
	Circuit 2		4.99 kg (11 lbs. 0 oz.)	510 kg (11 lbs. 4 oz.)	4.76 kg (10 lbs. 8 oz.)
	Circuit 3		4.99 kg (11 lbs. 0 oz.)	510 kg (11 lbs. 4 oz.)	4.76 kg (10 lbs. 8 oz.)
	Circuit 4		4.99 kg (11 lbs. 0 oz.)	510 kg (11 lbs. 4 oz.)	4.76 kg (10 lbs. 8 oz.)
Gas Heating Options Available - See page 15			Standard (2 Stage), Medium (2 Stage), or High (2 Stage)		
Compressor Type (no.)			Scroll (4)	Scroll (4)	Scroll (4)
Outdoor Coils	Net face area - m ² (sq. ft.) total		5.25 (56.5)	5.25 (56.5)	5.25 (56.5)
	Tube diameter - mm (in.)		9.5 (3/8)	9.5 (3/8)	9.5 (3/8)
	Number of rows		2	2	2
	Fins per meter (inch)		787 (20)	787 (20)	787 (20)
Outdoor Coil Fans	Motor Watts (horsepower)		(4) 249 (1/3)	(4) 249 (1/3)	(4) 249 (1/3)
	Motor rev/min		896	896	896
	Total Motor watts		1065	1065	1065
	Diameter - mm (in.)		(4) 610 (24)	(4) 610 (24)	(4) 610 (24)
	No. of blades		3	3	3
	Total Air volume - L/s (cfm)		6075 (12 900)	6075 (12 900)	6075 (12 900)
Indoor Coils	Net face area - m ² (sq. ft.) total		2.07 (22.3)	2.07 (22.3)	2.07 (22.3)
	Tube diameter - mm (in.)		9.5 (3/8)	9.5 (3/8)	9.5 (3/8)
	No. of rows		3	4	4
	Fins per meter (inch)		551 (14)	551 (14)	551 (14)
	Drain connection - number and size			(1) 1 in. NPT coupling	
Expansion device type			Balanced Port Thermostatic Expansion Valve, removeable power head		
³ Indoor Blower and Drive Selection	Nominal motor output		3.7 kW (5 hp)	5.6 kW (7.5 hp)	7.5 kW (10 hp)
	Maximum usable motor output		4.3 kW (5.75 hp)	6.4 kW (8.63 hp)	8.6 kW (11.5 hp)
	Motor - Drive kit number		3.7 kW kit #2 - 571 - 721 rev/min kit #3 - 708 - 871 rev/min kit #4 - 788 - 988 rev/min	5.6 kW kit# 5 - 788 - 988 rev/min kit# 6 - 871- 1071 rev/min kit# 7 - 708 - 871 rev/min	7.5 kW kit #6 - 871-1071 rev/min kit #8 - 945- 1138 rev/min
	Blower wheel nominal diameter x width - mm (in.)		(2) 381 x 381 (15 x 15)		
Filters	Type of filter		Disposable		
	No. and size - mm (in.)		(6) 610 x 610 x 51 (24 x 24 x 2)		
Electrical characteristics			380/420V - 50 hertz - 3 phase		

NOTE - Net capacity includes evaporator blower motor heat deduction. Gross capacity does not include evaporator blower motor heat deduction.

¹ Rating test conditions are those included in Air-Conditioning and Refrigeration Institute (ARI) Standard 340/360 while operating at rated voltage and air volumes; 35°C (95°F) outdoor air temperature and 27°C (80°F) db/19°C (67°F) wb entering evaporator air; minimum external duct static pressure.

² Integrated Part Load Value tested at 27°C (80°F) outdoor air temperature.

³ Using total air volume and system static pressure requirements determine from blower performance tables rev/min and motor output required. Maximum usable output of motors furnished are shown. If motors of comparable output are used, be sure to keep within the service factor limitations outlined on the motor nameplate.

SPECIFICATIONS

General Data		Nominal Size	88 kW		
		Model No.	LGC300S2B	LGC300S4B	
		Efficiency Type	Standard	Standard	
Cooling Performance	Gross Cooling Capacity - Btuh (kW)		80.5 (274 900)	77.0 (263 100)	
	¹ Net Cooling Capacity - Btuh (kW)		76.2 (260 200)	72.7 (248 400)	
	ARI Rated Air Flow - cfm (L/s)		4250 (9000)	4250 (9000)	
	Total Unit Power (kW)		27.7	26.4	
	¹ EER (Btuh/Watt)		9.4	9.4	
	² Integrated Part Load Value (Btuh/Watt)		9.7	9.7	
	Refrigerant Type		R-22	R-410A	
Refrigerant Charge Furnished	Circuit 1		5.10 kg (11 lbs. 4 oz.)	5.10 kg (11 lbs. 4 oz.)	
	Circuit 2		5.10 kg (11 lbs. 4 oz.)	5.10 kg (11 lbs. 4 oz.)	
	Circuit 3		5.10 kg (11 lbs. 4 oz.)	5.10 kg (11 lbs. 4 oz.)	
	Circuit 4		5.10 kg (11 lbs. 4 oz.)	5.10 kg (11 lbs. 4 oz.)	
Gas Heating Options Available - See page 15			Standard (2 Stage), Medium (2 Stage), or High (2 Stage)		
Compressor Type (no.)			Scroll (4)	Scroll (4)	
Outdoor Coils	Net face area - sq. ft. (m ²) total		56.5 (5.25)	56.5 (5.25)	
	Tube diameter - in. (mm) - No. of rows		9.5 (3/8) - 2	9.5 (3/8) - 2	
	Fins per inch (m)		787 (20)	787 (20)	
Outdoor Coil Fans	Motor horsepower (W)		(4) 373 (1/2)	(4) 373 (1/2)	
	Motor rev/min		896	896	
	Total Motor watts		1375	1375	
	Diameter - in. (mm) - No. of blades		(4) 610 (24) - 3	(4) 610 (24) - 3	
	Total Air volume - cfm (L/s)		6290 (13 300)	6290 (13 300)	
Indoor Coils	Net face area - sq. ft. (m ²) total		2.07 (22.3)	2.07 (22.3)	
	Tube diameter - in. (mm) - No. of rows		9.5 (3/8) - 4	9.5 (3/8) - 4	
	Fins per inch (m)		551 (14)	551 (14)	
	Drain connection - number and size		(1) 1 in. NPT coupling	(1) 1 in. NPT coupling	
	Expansion device type		Balanced Port Thermostatic Expansion Valve, removeable power head		
³ Indoor Blower and Drive Selection	Nominal motor output		3.7 kW (5 hp)	5.6 kW (7.5 hp)	7.5 kW (10 hp)
	Maximum usable motor output		4.3 kW (5.75 hp)	6.4 kW (8.63 hp)	8.6 kW (11.5 hp)
	Motor - Drive kit		3.7 kW kit #2 - 571 - 721 rev/min kit #3 - 708 - 871 rev/min kit #4 - 788 - 988 rev/min	5.6 kW kit# 5 - 788 - 988 rev/min kit# 6 - 871-1071 rev/min kit# 7 - 708 - 871 rev/min	7.5 kW kit #6 - 871-1071 rev/min kit #8 - 945-1138 rev/min
Blower wheel nominal diameter x width - mm (in.)			(2) 381 x 381 (15 x 15)	(2) 381 x 381 (15 x 15)	
Filters	Type of filter		Disposable		
	Number and size - in. (mm)		(6) 610 x 610 x 51 (24 x 24 x 2)	(6) 610 x 610 x 51 (24 x 24 x 2)	
Electrical characteristics			380/420V - 50 hertz - 3 phase		

NOTE - Net capacity includes evaporator blower motor heat deduction. Gross capacity does not include evaporator blower motor heat deduction.

¹ Rating test conditions are those included in Air-Conditioning and Refrigeration Institute (ARI) Standard 340/360 while operating at rated voltage and air volumes; 35°C (95°F) outdoor air temperature and 27°C (80°F) db/19°C (67°F) wb entering evaporator air; minimum external duct static pressure.

² Integrated Part Load Value tested at 27°C (80°F) outdoor air temperature.

³ Using total air volume and system static pressure requirements determine from blower performance tables rev/min and motor output required. Maximum usable output of motors furnished are shown. If motors of comparable output are used, be sure to keep within the service factor limitations outlined on the motor nameplate.

SPECIFICATIONS - GAS HEAT

Usage Data		Model No.	-156, -180, -210	-156, -180, -210, -240, -300	-180, -210, -240, -300	
Gas Heating Performance	Heat Input Type		Low (1 Stage)	Standard (2 Stage)	Medium (2 Stage)	High (2 Stage)
	Input - kW (Btuh)	First Stage	49.5 (169 000)	49.5 (169 000)	68.5 (234 000)	91.4 (312 000)
		Second Stage	---	68.5 (234 000)	91.9 (314 000)	123.0 (420 000)
	Output - kW (Btuh)	First Stage	39.5 (135 000)	---	---	---
		Second Stage	---	54.8 (187 000)	73.5 (251 000)	98.4 (336 000)
	Thermal Efficiency		80.0%			
Gas Supply Connections		1 in. npt				
Recommended Gas Supply Pressure - Natural		1.7 kPa (7 in. w.g.)				
LPG/Propane		2.7 kPa (11 in. w.g.)				

HIGH ALTITUDE DERATE

Units may be installed at altitudes up to 610 m (2000 feet) above sea level without any modification. At altitudes above 610 m (2000 feet), units must be derated to match gas manifold pressures shown in table below. NOTE - This is the only permissible derate for these units.

	Altitude		Gas Manifold Pressure				Input Rate	
	m	ft.	Natural Gas		LPG/Propane		Natural Gas	
			kPa	in. w.g.	kPa	in. w.g.	kW	Btuh
Low	610 - 1372	2001 - 4500	0.52	2.6	1.82	7.3	49.5	169 000
Standard	610 - 1372	2001 - 4500	0.52	2.6	1.82	7.3	66.0	225 500
Medium	610 - 1372	2001 - 4500	0.52	2.6	1.82	7.3	88.7	303 000
High	610 - 1372	2001 - 4500	0.52	2.6	1.82	7.3	118.6	405 000

COOLING RATINGS

NOTE - For Temperatures and Capacities not shown in tables, see bulletin — Cooling Unit Rating Table Correction Factor Data in Miscellaneous Engineering Data section.

46 kW HIGH EFFICIENCY COOLING CAPACITY - ONE COMPRESSOR OPERATING

LGC156H2

Entering Wet Bulb Temperature	Total Air Volume		Outdoor Air Temperature Entering Outdoor Coil																							
			18°C (65°F)						24°C (75°F)						29°C (85°F)						35°C (95°F)					
			Total Cooling Capacity		Comp Motor kW Input	Sensible To Total Ratio (S/T) Dry Bulb			Total Cooling Capacity		Comp Motor kW Input	Sensible To Total Ratio (S/T) Dry Bulb			Total Cooling Capacity		Comp Motor kW Input	Sensible To Total Ratio (S/T) Dry Bulb			Total Cooling Capacity		Comp Motor kW Input	Sensible To Total Ratio (S/T) Dry Bulb		
			kW	kBtu/h		24°C 75°F	27°C 80°F	29°C 85°F	kW	kBtu/h		24°C 75°F	27°C 80°F	29°C 85°F	kW	kBtu/h		24°C 75°F	27°C 80°F	29°C 85°F	kW	kBtu/h		24°C 75°F	27°C 80°F	29°C 85°F
17°C (63°F)	1.96	4160	28.3	96.7	4.13	.66	.82	.98	27.5	94.0	4.66	.67	.84	.99	26.7	91.0	5.26	.68	.86	1.00	25.7	87.7	5.93	.69	.88	1.00
	2.45	5200	29.5	100.7	4.15	.71	.92	1.00	28.7	97.9	4.68	.73	.94	1.00	27.8	94.7	5.28	.74	.96	1.00	26.8	91.4	5.95	.76	.98	1.00
	2.94	6240	30.6	104.3	4.17	.78	.99	1.00	29.8	101.6	4.69	.80	1.00	1.00	28.9	98.5	5.29	.82	1.00	1.00	27.9	95.2	5.96	.84	1.00	1.00
19°C (67°F)	1.96	4160	30.3	103.4	4.17	.51	.64	.78	29.4	100.4	4.69	.52	.64	.79	28.4	97.0	5.28	.52	.65	.81	27.4	93.5	5.96	.53	.66	.83
	2.45	5200	31.4	107.0	4.19	.54	.69	.87	30.4	103.8	4.71	.55	.70	.89	29.4	100.2	5.30	.56	.71	.92	28.2	96.3	5.97	.57	.73	.94
	2.94	6240	32.1	109.6	4.20	.57	.75	.96	31.1	106.2	4.73	.58	.77	.98	30.0	102.4	5.32	.59	.79	.99	28.8	98.4	5.99	.60	.81	1.00
22°C (71°F)	1.96	4160	32.5	110.9	4.21	.38	.50	.61	31.6	107.7	4.73	.39	.50	.62	30.5	104.0	5.32	.39	.51	.63	29.3	100.0	5.99	.39	.52	.64
	2.45	5200	33.6	114.5	4.23	.39	.53	.66	32.5	110.9	4.75	.40	.54	.67	31.4	107.0	5.34	.40	.54	.69	30.1	102.8	6.01	.40	.55	.70
	2.94	6240	34.3	116.9	4.24	.41	.56	.72	33.2	113.2	4.76	.41	.57	.74	31.9	109.0	5.34	.41	.58	.76	30.7	104.7	6.01	.42	.59	.79

46 kW HIGH EFFICIENCY COOLING CAPACITY - ALL COMPRESSORS OPERATING

LGC156H2

Entering Wet Bulb Temperature	Total Air Volume		Outdoor Air Temperature Entering Outdoor Coil																							
			27°C (80°F)						35°C (95°F)						43°C (110°F)						52°C (125°F)					
			Total Cooling Capacity		Comp Motor kW Input	Sensible To Total Ratio (S/T) Dry Bulb			Total Cooling Capacity		Comp Motor kW Input	Sensible To Total Ratio (S/T) Dry Bulb			Total Cooling Capacity		Comp Motor kW Input	Sensible To Total Ratio (S/T) Dry Bulb			Total Cooling Capacity		Comp Motor kW Input	Sensible To Total Ratio (S/T) Dry Bulb		
			kW	kBtu/h		24°C 75°F	27°C 80°F	29°C 85°F	kW	kBtu/h		24°C 75°F	27°C 80°F	29°C 85°F	kW	kBtu/h		24°C 75°F	27°C 80°F	29°C 85°F	kW	kBtu/h		24°C 75°F	27°C 80°F	29°C 85°F
17°C (63°F)	1.96	4160	41.0	139.8	7.52	.70	.87	1.00	38.8	132.4	9.00	.72	.90	1.00	36.3	124.0	10.79	.74	.94	1.00	33.7	115.0	12.95	.78	.98	1.00
	2.45	5200	42.6	145.4	7.55	.76	.96	1.00	40.4	138.0	9.04	.79	.99	1.00	38.1	129.9	10.81	.82	1.00	1.00	35.6	121.4	12.95	.87	1.00	1.00
	2.94	6240	44.3	151.2	7.57	.83	1.00	1.00	42.1	143.8	9.06	.86	1.00	1.00	39.8	135.7	10.84	.90	1.00	1.00	37.1	126.5	12.98	.95	1.00	1.00
19°C (67°F)	1.96	4160	43.7	149.1	7.56	.55	.68	.82	41.4	141.1	9.06	.56	.70	.85	38.6	131.7	10.84	.57	.72	.90	35.7	121.8	12.97	.59	.75	.94
	2.45	5200	45.1	153.9	7.59	.58	.74	.92	42.6	145.3	9.07	.59	.76	.95	39.7	135.6	10.85	.61	.80	.99	36.7	125.3	12.98	.63	.84	1.00
	2.94	6240	46.1	157.4	7.61	.61	.80	.99	43.5	148.5	9.09	.63	.84	1.00	40.6	138.7	10.87	.65	.88	1.00	37.5	128.0	13.01	.68	.93	1.00
22°C (71°F)	1.96	4160	46.8	159.8	7.62	.40	.53	.66	44.2	150.9	9.09	.41	.54	.67	41.4	141.1	10.87	.41	.55	.70	38.2	130.4	13.01	.42	.57	.73
	2.45	5200	48.2	164.5	7.64	.42	.57	.71	45.5	155.1	9.12	.42	.58	.74	42.4	144.7	10.90	.43	.60	.77	39.1	133.4	13.04	.44	.62	.81
	2.94	6240	49.1	167.7	7.67	.43	.60	.77	46.3	157.9	9.14	.44	.62	.81	43.1	147.1	10.91	.45	.64	.85	39.7	135.6	13.04	.46	.67	.90

46 kW HIGH EFFICIENCY (R-410A) COOLING CAPACITY - ONE COMPRESSOR OPERATING

LGC156H4

Entering Wet Bulb Temperature	Total Air Volume		Outdoor Air Temperature Entering Outdoor Coil																							
			18°C (65°F)						24°C (75°F)						29°C (85°F)						35°C (95°F)					
			Total Cooling Capacity		Comp Motor kW Input	Sensible To Total Ratio (S/T) Dry Bulb			Total Cooling Capacity		Comp Motor kW Input	Sensible To Total Ratio (S/T) Dry Bulb			Total Cooling Capacity		Comp Motor kW Input	Sensible To Total Ratio (S/T) Dry Bulb			Total Cooling Capacity		Comp Motor kW Input	Sensible To Total Ratio (S/T) Dry Bulb		
			kW	kBtu/h		24°C 75°F	27°C 80°F	29°C 85°F	kW	kBtu/h		24°C 75°F	27°C 80°F	29°C 85°F	kW	kBtu/h		24°C 75°F	27°C 80°F	29°C 85°F	kW	kBtu/h		24°C 75°F	27°C 80°F	29°C 85°F
17°C (63°F)	1.96	4160	29.2	99.6	3.92	.68	.84	.98	28.3	96.4	4.45	.69	.85	.99	27.2	92.9	5.05	.70	.87	1.00	26.1	89.1	5.72	.71	.89	1.00
	2.45	5200	30.4	103.6	3.94	.73	.92	1.00	29.4	100.3	4.48	.75	.94	1.00	28.3	96.6	5.07	.77	.96	1.00	27.2	92.8	5.74	.79	.98	1.00
	2.94	6240	31.4	107.2	3.96	.80	.99	1.00	30.5	103.9	4.49	.82	1.00	1.00	29.5	100.6	5.08	.84	1.00	1.00	28.4	96.9	5.75	.86	1.00	1.00
19°C (67°F)	1.96	4160	31.2	106.3	3.96	.53	.66	.79	30.1	102.8	4.49	.54	.66	.81	29.0	99.0	5.08	.54	.68	.83	27.8	94.9	5.75	.55	.69	.85
	2.45	5200	32.2	109.9	3.98	.56	.71	.88	31.1	106.2	4.50	.57	.72	.90	30.0	102.2	5.10	.58	.74	.93	28.7	97.8	5.76	.59	.76	.95
	2.94	6240	33.0	112.5	3.98	.59	.77	.96	31.8	108.6	4.52	.60	.79	.98	30.6	104.4	5.10	.61	.81	.99	29.3	100.0	5.77	.62	.83	1.00
22°C (71°F)	1.96	4160	33.4	113.9	4.00	.40	.51	.63	32.3	110.1	4.52	.40	.52	.64	31.1	106.1	5.11	.40	.53	.65	29.8	101.6	5.78	.40	.53	.67
	2.45	5200	34.4	117.5	4.01	.41	.55	.69	33.2	113.4	4.54	.41	.56	.70	32.0	109.1	5.12	.41	.56	.71	30.6	104.4	5.79	.42	.57	.73
	2.94	6240	35.2	120.0	4.02	.42	.58	.74	33.9	115.6	4.55	.42	.59	.76	32.6	111.1	5.14	.43	.60	.78	31.2	106.3	5.80	.43	.62	.81

46 kW HIGH EFFICIENCY (R-410A) COOLING CAPACITY - ALL COMPRESSORS OPERATING

LGC156H4

Entering Wet Bulb Temperature	Total Air Volume		Outdoor Air Temperature Entering Outdoor Coil																							
			27°C (80°F)						35°C (95°F)						43°C (110°F)						52°C (125°F)					
			Total Cooling Capacity		Comp Motor kW Input	Sensible To Total Ratio (S/T) Dry Bulb			Total Cooling Capacity		Comp Motor kW Input	Sensible To Total Ratio (S/T) Dry Bulb			Total Cooling Capacity		Comp Motor kW Input	Sensible To Total Ratio (S/T) Dry Bulb			Total Cooling Capacity		Comp Motor kW Input	Sensible To Total Ratio (S/T) Dry Bulb		
			kW	kBtu/h		24°C 75°F	27°C 80°F	29°C 85°F	kW	kBtu/h		24°C 75°F	27°C 80°F	29°C 85°F	kW	kBtu/h		24°C 75°F	27°C 80°F	29°C 85°F	kW	kBtu/h		24°C 75°F	27°C 80°F	29°C 85°F
17°C (63°F)	1.96	4160	41.1	140.1	7.21	.72	.87	1.00	38.7	132.0	8.67	.74	.91	1.00	36.1	123.1	10.43	.76	.94	1.00	33.3	113.5	12.58	.80	.99	1.00
	2.45	5200	42.7	145.7	7.24	.78	.96	1.00	40.3	137.6	8.70	.80	.99	1.00	37.8	129.1	10.45	.84	1.00	1.00	35.2	120.0	12.58	.89	1.00	1.00
	2.94	6240	44.4	151.4	7.24	.84	1.00	1.00	42.1	143.5	8.71	.87	1.00	1.00	39.5	134.7	10.47	.91	1.00	1.00	36.6	125.0	12.62	.96	1.00	1.00
19°C (67°F)	1.96	4160	43.8	149.3	7.24	.56	.69	.84	41.2	140.6	8.71	.57	.71	.87	38.3	130.7	10.47	.58	.74	.91	35.2	120.1	12.61	.60	.77	.95
	2.45	5200	45.2	154.1	7.27	.59	.75	.93	42.5	144.9	8.73	.61	.78	.96	39.4	134.5	10.49	.63	.82	.99	36.2	123.6	12.63	.65	.86	1.00
	2.94	6240	46.1	157.4	7.30	.63	.82	.99	43.4	148.0	8.74	.65	.85	1.00	40.4	137.7	10.49	.67	.89	1.00	37.0	126.4	12.65	.70	.94	1.00
22°C (71°F)	1.96	4160	46.9	159.9	7.30	.41	.54	.67	44.1	150.4	8.76	.42	.55	.69	41.1	140.1	10.52	.42	.57	.72	37.7	128.7	12.65	.43	.59	.75
	2.45	5200	48.2	164.5	7.33	.43	.58	.73	45.3	154.5	8.77	.43	.60	.75	42.1	143.7	10.52	.44	.61	.79	38.6	131.7	12.67	.45	.64	.83
	2.94	6240	49.1	167.6	7.33	.44	.62	.79	46.1	157.4	8.79	.45	.64	.82	42.8	146.1	10.55	.46	.66	.87	39.2	133.8	12.68	.47	.69	.92

COOLING RATINGS

NOTE - For Temperatures and Capacities not shown in tables, see bulletin — Cooling Unit Rating Table Correction Factor Data in Miscellaneous Engineering Data section.

53 kW STANDARD EFFICIENCY COOLING CAPACITY - ONE COMPRESSOR OPERATING

LGC180S2

Entering Wet Bulb Temperature	Total Air Volume		Outdoor Air Temperature Entering Outdoor Coil																							
			18°C (65°F)						24°C (75°F)						29°C (85°F)						35°C (95°F)					
			Total Cooling Capacity		Comp Motor kW Input	Sensible To Total Ratio (S/T) Dry Bulb			Total Cooling Capacity		Comp Motor kW Input	Sensible To Total Ratio (S/T) Dry Bulb			Total Cooling Capacity		Comp Motor kW Input	Sensible To Total Ratio (S/T) Dry Bulb			Total Cooling Capacity		Comp Motor kW Input	Sensible To Total Ratio (S/T) Dry Bulb		
			kW	kBtuh		24°C 75°F	27°C 80°F	29°C 85°F	kW	kBtuh		24°C 75°F	27°C 80°F	29°C 85°F	kW	kBtuh		24°C 75°F	27°C 80°F	29°C 85°F	kW	kBtuh		24°C 75°F	27°C 80°F	29°C 85°F
17°C (63°F)	2.26	4800	33.1	112.9	6.04	.69	.84	.98	32.2	109.9	6.63	.69	.85	.99	31.2	106.3	7.30	.70	.87	1.00	30.0	102.5	8.09	.71	.89	1.00
	2.83	6000	34.3	117.0	6.12	.74	.92	1.00	33.4	113.9	6.71	.75	.94	1.00	32.3	110.3	7.40	.77	.95	1.00	31.2	106.5	8.18	.78	.97	1.00
	3.40	7200	35.3	120.6	6.19	.80	.99	1.00	34.5	117.6	6.78	.82	.99	1.00	33.5	114.2	7.48	.83	1.00	1.00	32.4	110.5	8.27	.85	1.00	1.00
19°C (67°F)	2.26	4800	35.1	119.7	6.17	.54	.66	.80	34.1	116.5	6.76	.54	.67	.81	33.1	112.8	7.45	.55	.68	.83	31.9	108.7	8.23	.55	.69	.85
	2.83	6000	36.1	123.2	6.25	.57	.72	.89	35.2	120.0	6.84	.57	.73	.90	34.0	116.0	7.52	.58	.74	.92	32.8	111.8	8.32	.59	.76	.94
	3.40	7200	36.8	125.7	6.31	.60	.78	.96	35.9	122.4	6.89	.61	.79	.97	34.7	118.4	7.58	.61	.81	.99	33.4	114.1	8.36	.63	.83	1.00
22°C (71°F)	2.26	4800	37.2	127.1	6.33	.40	.52	.64	36.3	123.9	6.92	.40	.53	.65	35.2	120.1	7.60	.40	.53	.66	33.9	115.8	8.40	.41	.54	.67
	2.83	6000	38.3	130.6	6.40	.41	.55	.70	37.3	127.2	6.98	.42	.56	.71	36.1	123.2	7.68	.42	.57	.72	34.8	118.8	8.47	.42	.58	.73
	3.40	7200	38.9	132.8	6.45	.43	.59	.76	38.0	129.5	7.04	.43	.60	.77	36.8	125.4	7.72	.43	.61	.79	35.4	120.7	8.52	.44	.62	.81

53 kW STANDARD EFFICIENCY COOLING CAPACITY - ALL COMPRESSORS OPERATING

LGC180S2

Entering Wet Bulb Temperature	Total Air Volume		Outdoor Air Temperature Entering Outdoor Coil																							
			27°C (80°F)						35°C (95°F)						43°C (110°F)						52°C (125°F)					
			Total Cooling Capacity		Comp Motor kW Input	Sensible To Total Ratio (S/T) Dry Bulb			Total Cooling Capacity		Comp Motor kW Input	Sensible To Total Ratio (S/T) Dry Bulb			Total Cooling Capacity		Comp Motor kW Input	Sensible To Total Ratio (S/T) Dry Bulb			Total Cooling Capacity		Comp Motor kW Input	Sensible To Total Ratio (S/T) Dry Bulb		
			kW	kBtuh		24°C 75°F	27°C 80°F	29°C 85°F	kW	kBtuh		24°C 75°F	27°C 80°F	29°C 85°F	kW	kBtuh		24°C 75°F	27°C 80°F	29°C 85°F	kW	kBtuh		24°C 75°F	27°C 80°F	29°C 85°F
17°C (63°F)	2.26	4800	48.1	164.2	10.80	.71	.87	1.00	45.6	155.5	12.56	.73	.89	1.00	42.8	146.2	14.71	.75	.93	1.00	40.3	137.5	17.29	.77	.96	1.00
	2.83	6000	49.9	170.3	10.94	.77	.95	1.00	47.3	161.4	12.71	.79	.97	1.00	44.7	152.4	14.87	.82	1.00	1.00	42.2	144.0	17.50	.86	1.00	1.00
	3.40	7200	51.6	176.0	11.06	.83	1.00	1.00	49.1	167.6	12.85	.86	1.00	1.00	46.5	158.6	15.04	.89	1.00	1.00	43.9	149.8	17.69	.93	1.00	1.00
19°C (67°F)	2.26	4800	51.1	174.2	11.03	.55	.69	.83	48.3	164.9	12.78	.56	.71	.85	45.4	154.9	14.96	.58	.73	.89	42.6	145.2	17.56	.59	.75	.92
	2.83	6000	52.5	179.2	11.13	.59	.75	.92	49.7	169.7	12.91	.60	.77	.94	46.7	159.2	15.08	.62	.80	.98	43.7	149.0	17.70	.64	.83	1.00
	3.40	7200	53.6	182.9	11.21	.62	.81	.98	50.7	173.1	12.99	.64	.84	1.00	47.6	162.5	15.17	.66	.87	1.00	44.6	152.1	17.81	.68	.91	1.00
22°C (71°F)	2.26	4800	54.3	185.3	11.27	.41	.54	.67	51.5	175.8	13.04	.42	.55	.68	48.4	165.1	15.25	.42	.56	.70	45.3	154.7	17.89	.43	.58	.73
	2.83	6000	55.7	190.2	11.37	.43	.58	.73	52.8	180.2	13.16	.43	.59	.75	49.6	169.2	15.37	.44	.61	.77	46.4	158.2	18.03	.44	.63	.81
	3.40	7200	56.7	193.5	11.45	.44	.61	.79	53.7	183.2	13.25	.45	.63	.82	50.4	171.9	15.44	.45	.65	.85	47.0	160.5	18.12	.46	.67	.89

53 kW HIGH EFFICIENCY COOLING CAPACITY - ONE COMPRESSOR OPERATING

LGC180H2

Entering Wet Bulb Temperature	Total Air Volume		Outdoor Air Temperature Entering Outdoor Coil																							
			18°C (65°F)						24°C (75°F)						29°C (85°F)						35°C (95°F)					
			Total Cooling Capacity		Comp Motor kW Input	Sensible To Total Ratio (S/T) Dry Bulb			Total Cooling Capacity		Comp Motor kW Input	Sensible To Total Ratio (S/T) Dry Bulb			Total Cooling Capacity		Comp Motor kW Input	Sensible To Total Ratio (S/T) Dry Bulb			Total Cooling Capacity		Comp Motor kW Input	Sensible To Total Ratio (S/T) Dry Bulb		
			kW	kBtuh		24°C 75°F	27°C 80°F	29°C 85°F	kW	kBtuh		24°C 75°F	27°C 80°F	29°C 85°F	kW	kBtuh		24°C 75°F	27°C 80°F	29°C 85°F	kW	kBtuh		24°C 75°F	27°C 80°F	29°C 85°F
17°C (63°F)	2.26	4800	34.3	117.2	5.18	.68	.83	.96	33.4	113.8	5.80	.69	.84	.98	32.4	110.4	6.52	.70	.85	.99	31.2	106.4	7.36	.71	.87	1.00
	2.83	6000	35.6	121.6	5.20	.73	.91	1.00	34.6	118.2	5.84	.74	.92	1.00	33.5	114.4	6.56	.76	.94	1.00	32.4	110.4	7.40	.77	.96	1.00
	3.40	7200	36.8	125.4	5.24	.79	.97	1.00	35.7	121.8	5.86	.80	.98	1.00	34.6	118.2	6.58	.82	1.00	1.00	33.5	114.4	7.42	.84	1.00	1.00
19°C (67°F)	2.26	4800	36.5	124.6	5.24	.55	.66	.79	35.5	121.0	5.86	.54	.66	.80	34.3	117.2	6.58	.54	.67	.82	33.1	113.0	7.42	.55	.68	.83
	2.83	6000	37.7	128.6	5.26	.56	.71	.87	36.6	124.8	5.88	.57	.72	.88	35.3	120.6	6.62	.58	.73	.90	34.1	116.2	7.46	.58	.75	.93
	3.40	7200	38.5	131.4	5.30	.59	.77	.94	37.3	127.4	5.92	.60	.78	.96	36.1	123.2	6.64	.61	.80	.97	34.8	118.6	7.48	.62	.82	.99
22°C (71°F)	2.26	4800	38.9	132.8	5.30	.40	.52	.63	37.8	129.0	5.94	.40	.52	.64	36.6	124.8	6.66	.40	.53	.65	35.3	120.4	7.48	.41	.53	.66
	2.83	6000	40.1	136.8	5.34	.41	.55	.69	38.9	132.6	5.96	.41	.56	.70	37.6	128.2	6.70	.42	.56	.71	36.2	123.6	7.54	.42	.57	.72
	3.40	7200	40.9	139.4	5.36	.42	.58	.74	39.6	135.2	6.00	.43	.59	.76	38.3	130.6	6.72	.43	.60	.77	36.9	125.8	7.56	.43	.61	.79

53 kW HIGH EFFICIENCY COOLING CAPACITY - ALL COMPRESSORS OPERATING

LGC180H2

Entering Wet Bulb Temperature	Total Air Volume		Outdoor Air Temperature Entering Outdoor Coil																							
			27°C (80°F)						35°C (95°F)						43°C (110°F)						52°C (125°F)					
			Total Cooling Capacity		Comp Motor kW Input	Sensible To Total Ratio (S/T) Dry Bulb			Total Cooling Capacity		Comp Motor kW Input	Sensible To Total Ratio (S/T) Dry Bulb			Total Cooling Capacity		Comp Motor kW Input	Sensible To Total Ratio (S/T) Dry Bulb			Total Cooling Capacity		Comp Motor kW Input	Sensible To Total Ratio (S/T) Dry Bulb		
			kW	kBtuh		24°C 75°F	27°C 80°F	29°C 85°F	kW	kBtuh		24°C 75°F	27°C 80°F	29°C 85°F	kW	kBtuh		24°C 75°F	27°C 80°F	29°C 85°F	kW	kBtuh		24°C 75°F	27°C 80°F	29°C 85°F
17°C (63°F)	2.26	4800	48.5	165.4	9.37	.71	.86	1.00	46.0	156.9	11.22	.72	.89	1.00	43.2	147.5	13.53	.74	.92	1.00	40.4	137.8	16.31	.77	.96	1.00
	2.83	6000	50.3	171.6	9.43	.76	.95	1.00	47.8	163.0	11.31	.79	.97	1.00	45.0	153.7	13.58	.82	1.00	1.00	42.4	144.6	16.34	.85	1.00	1.00
	3.40	7200	52.1	177.7	9.48	.83	1.00	1.00	49.6	169.2	11.34	.85	1.00	1.00	46.9	160.1	13.65	.89	1.00	1.00	44.1	150.4	16.43	.93	1.00	1.00
19°C (67°F)	2.26	4800	51.5	175.7	9.46	.55	.68	.82	48.8	166.6	11.34	.56	.70	.85	45.8	156.4	13.64	.57	.72	.88	42.7	145.7	16.40	.59	.75	.92
	2.83	6000	53.0	181.0	9.52	.58	.74	.91	50.2	171.3	11.40	.60	.76	.94	47.1	160.7	13.67	.61	.79	.97	43.8	149.6	16.45	.63	.83	1.00
	3.40	7200	54.2	184.8	9.57	.62	.80	.98	51.2	174.8	11.43	.63	.83	1.00	48.1	164.2	13.71	.65	.87	1.00	44.8	152.8	16.49	.68	.91	1.00
22°C (71°F)	2.26	4800	54.9	187.4	9.58	.41	.54	.66	52.1	177.7	11.45	.41	.54	.68	48.9	166.9	13.76	.42	.56	.70	45.5	155.4	16.52	.42	.57	.72
	2.83	6000	56.5	192.7	9.64	.42	.57	.72	53.5	182.4	11.49	.43	.58	.74	50.1	171.0	13.79	.43	.60	.77	46.6	159.0	16.57	.44	.62	.80
	3.40	7200	57.5	196.2	9.67	.43	.61	.78	54.3	185.4	11.55	.44	.62	.81	50.9	173.7	13.83	.45	.64	.84	47.4	161.6	16.61	.46	.67	.89

COOLING RATINGS

NOTE - For Temperatures and Capacities not shown in tables, see bulletin — Cooling Unit Rating Table Correction Factor Data in Miscellaneous Engineering Data section.

53 KW HIGH EFFICIENCY (R-410A) COOLING CAPACITY - ONE COMPRESSOR OPERATING

LGC180H4

Entering Wet Bulb Temperature	Total Air Volume		Outdoor Air Temperature Entering Outdoor Coil																							
			18°C (65°F)						24°C (75°F)						29°C (85°F)						35°C (95°F)					
			Total Cooling Capacity		Comp Motor kW Input	Sensible To Total Ratio (S/T) Dry Bulb			Total Cooling Capacity		Comp Motor kW Input	Sensible To Total Ratio (S/T) Dry Bulb			Total Cooling Capacity		Comp Motor kW Input	Sensible To Total Ratio (S/T) Dry Bulb			Total Cooling Capacity		Comp Motor kW Input	Sensible To Total Ratio (S/T) Dry Bulb		
			kW	kBtu/h		24°C 75°F	27°C 80°F	29°C 85°F	kW	kBtu/h		24°C 75°F	27°C 80°F	29°C 85°F	kW	kBtu/h		24°C 75°F	27°C 80°F	29°C 85°F	kW	kBtu/h		24°C 75°F	27°C 80°F	29°C 85°F
17°C (63°F)	2.26	4800	34.8	118.8	4.89	.68	.83	.96	33.5	114.3	5.57	.69	.84	.98	32.1	109.6	6.34	.70	.86	.99	30.6	104.4	7.21	.72	.89	1.00
	2.83	6000	36.2	123.5	4.92	.73	.91	1.00	34.8	118.8	5.61	.74	.93	1.00	33.4	113.8	6.38	.76	.95	1.00	31.9	108.7	7.25	.79	.97	1.00
	3.40	7200	37.4	127.5	4.95	.79	.97	1.00	36.0	122.8	5.64	.81	.98	1.00	34.5	117.8	6.41	.83	.99	1.00	33.0	112.7	7.28	.86	1.00	1.00
19°C (67°F)	2.26	4800	37.1	126.5	4.94	.53	.65	.79	35.6	121.6	5.64	.54	.67	.80	34.1	116.5	6.40	.55	.68	.83	32.5	110.8	7.28	.55	.69	.85
	2.83	6000	38.3	130.7	4.98	.56	.70	.87	36.8	125.5	5.66	.57	.72	.89	35.2	120.0	6.43	.58	.74	.91	33.4	114.1	7.31	.59	.76	.94
	3.40	7200	39.2	133.7	5.00	.59	.76	.94	37.6	128.2	5.69	.60	.78	.96	35.9	122.5	6.46	.61	.81	.98	34.1	116.5	7.33	.63	.83	.99
22°C (71°F)	2.26	4800	39.6	135.1	5.00	.40	.52	.63	38.0	129.8	5.70	.40	.52	.64	36.4	124.2	6.47	.40	.53	.65	34.6	118.2	7.35	.41	.54	.67
	2.83	6000	40.8	139.2	5.04	.41	.55	.68	39.2	133.6	5.74	.41	.56	.70	37.4	127.7	6.51	.42	.57	.71	35.6	121.4	7.38	.42	.58	.74
	3.40	7200	41.6	142.0	5.06	.42	.58	.74	39.9	136.2	5.76	.43	.59	.76	38.1	129.9	6.53	.43	.60	.78	36.2	123.4	7.40	.44	.62	.81

53 KW HIGH EFFICIENCY (R-410A) COOLING CAPACITY - ALL COMPRESSORS OPERATING

LGC180H4

Entering Wet Bulb Temperature	Total Air Volume		Outdoor Air Temperature Entering Outdoor Coil																							
			27°C (80°F)						35°C (95°F)						43°C (110°F)						52°C (125°F)					
			Total Cooling Capacity		Comp Motor kW Input	Sensible To Total Ratio (S/T) Dry Bulb			Total Cooling Capacity		Comp Motor kW Input	Sensible To Total Ratio (S/T) Dry Bulb			Total Cooling Capacity		Comp Motor kW Input	Sensible To Total Ratio (S/T) Dry Bulb			Total Cooling Capacity		Comp Motor kW Input	Sensible To Total Ratio (S/T) Dry Bulb		
			kW	kBtu/h		24°C 75°F	27°C 80°F	29°C 85°F	kW	kBtu/h		24°C 75°F	27°C 80°F	29°C 85°F	kW	kBtu/h		24°C 75°F	27°C 80°F	29°C 85°F	kW	kBtu/h		24°C 75°F	27°C 80°F	29°C 85°F
17°C (63°F)	2.26	4800	49.3	168.1	8.93	.70	.86	.99	45.9	156.6	10.82	.73	.89	1.00	42.2	143.9	13.17	.76	.94	1.00	38.0	129.8	16.13	.81	.99	1.00
	2.83	6000	51.2	174.6	8.99	.76	.94	1.00	47.8	163.0	10.88	.79	.97	1.00	44.1	150.5	13.23	.84	.99	1.00	40.0	136.6	16.18	.90	1.00	1.00
	3.40	7200	52.9	180.6	9.04	.82	.99	1.00	49.6	169.1	10.93	.86	1.00	1.00	45.9	156.5	13.28	.91	1.00	1.00	41.6	142.0	16.22	.96	1.00	1.00
19°C (67°F)	2.26	4800	52.3	178.5	9.02	.55	.68	.82	48.7	166.1	10.92	.56	.70	.86	44.6	152.2	13.26	.58	.73	.90	39.9	136.2	16.19	.60	.78	.96
	2.83	6000	53.9	184.0	9.07	.58	.74	.91	50.1	171.0	10.97	.60	.77	.95	45.9	156.5	13.32	.62	.81	.98	41.0	140.0	16.24	.65	.87	1.00
	3.40	7200	55.1	188.0	9.11	.61	.80	.97	51.1	174.5	11.00	.64	.84	.99	46.8	159.8	13.35	.66	.89	1.00	42.0	143.2	16.27	.70	.95	1.00
22°C (71°F)	2.26	4800	55.9	190.6	9.13	.41	.53	.66	51.9	177.2	11.03	.41	.55	.68	47.6	162.4	13.37	.42	.57	.71	42.6	145.3	16.28	.43	.59	.75
	2.83	6000	57.4	195.9	9.19	.42	.57	.72	53.3	181.8	11.08	.43	.59	.74	48.7	166.1	13.41	.44	.61	.78	43.5	148.4	16.33	.45	.65	.85
	3.40	7200	58.5	199.6	9.22	.43	.60	.77	54.2	184.8	11.11	.44	.63	.81	49.5	168.8	13.45	.45	.66	.87	44.1	150.6	16.35	.47	.70	.93

62 KW STANDARD EFFICIENCY COOLING CAPACITY - ONE COMPRESSOR OPERATING

LGC210S2

Entering Wet Bulb Temperature	Total Air Volume		Outdoor Air Temperature Entering Outdoor Coil																							
			18°C (65°F)						24°C (75°F)						29°C (85°F)						35°C (95°F)					
			Total Cooling Capacity		Comp Motor kW Input	Sensible To Total Ratio (S/T) Dry Bulb			Total Cooling Capacity		Comp Motor kW Input	Sensible To Total Ratio (S/T) Dry Bulb			Total Cooling Capacity		Comp Motor kW Input	Sensible To Total Ratio (S/T) Dry Bulb			Total Cooling Capacity		Comp Motor kW Input	Sensible To Total Ratio (S/T) Dry Bulb		
			kW	kBtu/h		24°C 75°F	27°C 80°F	29°C 85°F	kW	kBtu/h		24°C 75°F	27°C 80°F	29°C 85°F	kW	kBtu/h		24°C 75°F	27°C 80°F	29°C 85°F	kW	kBtu/h		24°C 75°F	27°C 80°F	29°C 85°F
17°C (63°F)	2.64	5600	28.0	95.4	5.08	.66	.83	.98	27.1	92.4	5.62	.67	.84	1.00	26.1	89.2	6.24	.68	.87	1.00	25.1	85.6	6.96	.69	.89	1.00
	3.30	7000	29.0	98.8	5.14	.72	.92	1.00	28.1	95.8	5.70	.73	.94	1.00	27.1	92.4	6.32	.75	.96	1.00	26.1	89.0	7.06	.77	.98	1.00
	3.96	8400	29.9	102.0	5.22	.79	.99	1.00	29.0	98.8	5.78	.80	1.00	1.00	28.0	95.6	6.42	.83	1.00	1.00	27.1	92.4	7.14	.85	1.00	1.00
19°C (67°F)	2.64	5600	29.7	101.2	5.20	.52	.64	.78	28.7	97.8	5.76	.52	.65	.80	27.7	94.4	6.38	.53	.66	.83	26.6	90.6	7.10	.54	.67	.85
	3.30	7000	30.5	104.0	5.26	.55	.69	.88	29.5	100.6	5.82	.55	.70	.90	28.4	96.8	6.46	.56	.73	.93	27.3	93.0	7.18	.57	.75	.95
	3.96	8400	31.1	106.2	5.32	.58	.76	.97	30.1	102.6	5.88	.59	.78	.98	29.0	98.8	6.50	.60	.80	.99	27.8	94.8	7.22	.61	.83	1.00
22°C (71°F)	2.64	5600	31.5	107.4	5.34	.39	.50	.62	30.5	104.0	5.90	.39	.51	.63	29.4	100.2	6.54	.39	.52	.64	28.3	96.4	7.26	.39	.52	.65
	3.30	7000	32.3	110.2	5.40	.40	.54	.67	31.2	106.6	5.96	.40	.54	.69	30.1	102.8	6.62	.40	.55	.70	28.9	98.6	7.34	.41	.56	.72
	3.96	8400	32.9	112.2	5.46	.41	.57	.74	31.8	108.4	6.02	.41	.58	.75	30.6	104.4	6.66	.42	.59	.78	29.3	100.0	7.38	.42	.60	.80

62 KW STANDARD EFFICIENCY COOLING CAPACITY - ALL COMPRESSORS OPERATING

LGC210S2

Entering Wet Bulb Temperature	Total Air Volume		Outdoor Air Temperature Entering Outdoor Coil																							
			27°C (80°F)						35°C (95°F)						43°C (110°F)						52°C (125°F)					
			Total Cooling Capacity		Comp Motor kW Input	Sensible To Total Ratio (S/T) Dry Bulb			Total Cooling Capacity		Comp Motor kW Input	Sensible To Total Ratio (S/T) Dry Bulb			Total Cooling Capacity		Comp Motor kW Input	Sensible To Total Ratio (S/T) Dry Bulb			Total Cooling Capacity		Comp Motor kW Input	Sensible To Total Ratio (S/T) Dry Bulb		
			kW	kBtu/h		24°C 75°F	27°C 80°F	29°C 85°F	kW	kBtu/h		24°C 75°F	27°C 80°F	29°C 85°F	kW	kBtu/h		24°C 75°F	27°C 80°F	29°C 85°F	kW	kBtu/h		24°C 75°F	27°C 80°F	29°C 85°F
17°C (63°F)	2.64	5600	55.3	188.6	11.94	.71	.87	1.00	52.2	178.0	14.04	.73	.90	1.00	48.8	166.6	16.62	.75	.94	1.00	45.1	153.8	19.74	.79	.98	1.00
	3.30	7000	57.2	195.2	12.10	.77	.96	1.00	54.2	184.8	14.24	.80	.98	1.00	50.9	173.6	16.82	.83	1.00	1.00	47.3	161.4	19.98	.88	1.00	1.00
	3.96	8400	59.1	201.8	12.26	.83	1.00	1.00	56.2	191.8	14.40	.87	1.00	1.00	52.9	180.4	17.02	.91	1.00	1.00	49.1	167.4	20.16	.95	1.00	1.00
19°C (67°F)	2.64	5600	58.4	199.4	12.22	.55	.69	.83	55.2	188.2	14.32	.56	.71	.86	51.4	175.4	16.92	.58	.73	.90	47.3	161.4	20.02	.60	.76	.95
	3.30	7000	60.1	205.2	12.36	.59	.75	.92	56.6	193.2	14.48	.60	.77	.96	52.8	180.2	17.04	.62	.81	.99	48.5	165.6	20.14	.64	.85	1.00
	3.96	8400	61.4	209.4	12.46	.62	.81	.99	57.7	197.0	14.58	.64	.85	1.00	53.9	183.8	17.16	.66	.88	1.00	49.5	169.0	20.26	.69	.93	1.00
22°C (71°F)	2.64	5600	62.2	212.2	12.54	.41	.54	.67	58.7	200.2	14.66	.41	.55	.69	54.7	186.6	17.26	.42	.57	.71	50.3	171.8	20.38	.43	.59	.74
	3.30	7000	63.8	217.6	12.66	.42	.58	.73	60.0	204.8	14.80	.43	.59	.75	55.9	190.8	17.38	.43	.61	.78	51.3	175.2	20.50	.45	.64	.83
	3.96	8400	64.8	221.0	12.76	.44	.61	.79	61.0	208.0	14.90	.44	.63	.82	56.8	193.8	17.48	.45	.65	.86	52.0	177.6	20.58	.46	.69	.91

COOLING RATINGS

NOTE - For Temperatures and Capacities not shown in tables, see bulletin — Cooling Unit Rating Table Correction Factor Data in Miscellaneous Engineering Data section.

62 kW HIGH EFFICIENCY COOLING CAPACITY - ONE COMPRESSOR OPERATING

LGC210H2

Entering Wet Bulb Temperature	Total Air Volume		Outdoor Air Temperature Entering Outdoor Coil																							
			18°C (65°F)						24°C (75°F)						29°C (85°F)						35°C (95°F)					
			Total Cooling Capacity		Comp Motor kW Input	Sensible To Total Ratio (S/T) Dry Bulb			Total Cooling Capacity		Comp Motor kW Input	Sensible To Total Ratio (S/T) Dry Bulb			Total Cooling Capacity		Comp Motor kW Input	Sensible To Total Ratio (S/T) Dry Bulb			Total Cooling Capacity		Comp Motor kW Input	Sensible To Total Ratio (S/T) Dry Bulb		
			kW	kBtuh		24°C 75°F	27°C 80°F	29°C 85°F	kW	kBtuh		24°C 75°F	27°C 80°F	29°C 85°F	kW	kBtuh		24°C 75°F	27°C 80°F	29°C 85°F	kW	kBtuh		24°C 75°F	27°C 80°F	29°C 85°F
17°C (63°F)	2.64	5600	29.2	99.8	4.37	.67	.84	1.00	28.4	96.9	4.93	.68	.86	1.00	27.4	93.6	5.57	.69	.88	1.00	26.4	90.0	6.27	.71	.90	1.00
	3.30	7000	30.5	103.9	4.41	.73	.94	1.00	29.5	100.8	4.97	.75	.96	1.00	28.6	97.5	5.59	.77	.98	1.00	27.5	93.9	6.30	.79	1.00	1.00
	3.96	8400	31.6	107.8	4.45	.81	1.00	1.00	30.7	104.9	4.99	.82	1.00	1.00	29.8	101.6	5.63	.85	1.00	1.00	28.8	98.1	6.33	.87	1.00	1.00
19°C (67°F)	2.64	5600	31.2	106.3	4.43	.52	.65	.79	30.2	103.0	4.99	.53	.66	.81	29.1	99.4	5.61	.54	.67	.83	28.0	95.6	6.32	.54	.68	.86
	3.30	7000	32.2	109.8	4.46	.56	.71	.90	31.2	106.3	5.01	.56	.72	.92	30.0	102.5	5.65	.57	.74	.94	28.8	98.4	6.35	.58	.76	.97
	3.96	8400	32.9	112.4	4.49	.59	.78	.98	31.8	108.6	5.03	.60	.80	.99	30.7	104.7	5.67	.61	.82	1.00	29.5	100.5	6.37	.62	.84	1.00
22°C (71°F)	2.64	5600	33.3	113.7	4.49	.39	.51	.63	32.3	110.1	5.05	.39	.51	.64	31.1	106.2	5.68	.39	.52	.65	29.9	102.0	6.38	.40	.53	.66
	3.30	7000	34.3	117.1	4.53	.40	.54	.68	33.2	113.3	5.07	.40	.55	.70	31.9	109.0	5.71	.41	.56	.71	30.7	104.6	6.41	.41	.57	.73
	3.96	8400	35.0	119.4	4.55	.42	.58	.75	33.8	115.4	5.09	.42	.59	.77	32.5	111.0	5.72	.42	.60	.79	31.2	106.4	6.43	.43	.61	.82

62 kW HIGH EFFICIENCY COOLING CAPACITY - ALL COMPRESSORS OPERATING

LGC210H2

Entering Wet Bulb Temperature	Total Air Volume		Outdoor Air Temperature Entering Outdoor Coil																							
			27°C (80°F)						35°C (95°F)						43°C (110°F)						52°C (125°F)					
			Total Cooling Capacity		Comp Motor kW Input	Sensible To Total Ratio (S/T) Dry Bulb			Total Cooling Capacity		Comp Motor kW Input	Sensible To Total Ratio (S/T) Dry Bulb			Total Cooling Capacity		Comp Motor kW Input	Sensible To Total Ratio (S/T) Dry Bulb			Total Cooling Capacity		Comp Motor kW Input	Sensible To Total Ratio (S/T) Dry Bulb		
			kW	kBtuh		24°C 75°F	27°C 80°F	29°C 85°F	kW	kBtuh		24°C 75°F	27°C 80°F	29°C 85°F	kW	kBtuh		24°C 75°F	27°C 80°F	29°C 85°F	kW	kBtuh		24°C 75°F	27°C 80°F	29°C 85°F
17°C (63°F)	2.64	5600	54.8	187.1	10.22	.71	.88	1.00	51.8	176.8	12.32	.73	.92	1.00	48.8	166.5	14.88	.75	.95	1.00	45.8	156.3	17.96	.78	.99	1.00
	3.30	7000	57.1	194.8	10.26	.77	.98	1.00	54.2	185.1	12.36	.80	1.00	1.00	51.3	175.1	14.96	.84	1.00	1.00	48.4	165.3	18.08	.88	1.00	1.00
	3.96	8400	59.5	203.1	10.28	.85	1.00	1.00	56.6	193.1	12.40	.89	1.00	1.00	53.5	182.7	15.00	.93	1.00	1.00	50.5	172.2	18.16	.97	1.00	1.00
19°C (67°F)	2.64	5600	58.2	198.7	10.30	.55	.69	.84	55.0	187.6	12.38	.56	.71	.87	51.7	176.3	15.00	.57	.73	.91	48.3	164.7	18.08	.59	.75	.96
	3.30	7000	59.9	204.5	10.30	.58	.75	.95	56.5	192.9	12.42	.60	.77	.98	53.1	181.1	15.04	.62	.81	1.00	49.6	169.4	18.16	.64	.85	1.00
	3.96	8400	61.2	208.9	10.32	.62	.82	1.00	57.8	197.2	12.44	.64	.86	1.00	54.3	185.2	15.08	.66	.90	1.00	50.8	173.5	18.24	.69	.94	1.00
22°C (71°F)	2.64	5600	62.1	212.0	10.34	.40	.53	.66	58.6	200.0	12.46	.41	.55	.68	55.1	187.9	15.12	.41	.56	.70	51.6	175.9	18.28	.42	.57	.73
	3.30	7000	63.7	217.4	10.34	.42	.57	.73	60.1	204.9	12.50	.42	.59	.75	56.4	192.4	15.16	.43	.61	.78	52.7	179.9	18.36	.44	.63	.82
	3.96	8400	64.8	221.2	10.34	.43	.62	.80	61.1	208.5	12.52	.44	.63	.83	57.3	195.6	15.20	.45	.66	.88	53.5	182.7	18.40	.46	.68	.92

62 kW HIGH EFFICIENCY (R-410A) COOLING CAPACITY - ONE COMPRESSOR OPERATING

LGC210H4

Entering Wet Bulb Temperature	Total Air Volume		Outdoor Air Temperature Entering Outdoor Coil																							
			18°C (65°F)						24°C (75°F)						29°C (85°F)						35°C (95°F)					
			Total Cooling Capacity		Comp Motor kW Input	Sensible To Total Ratio (S/T) Dry Bulb			Total Cooling Capacity		Comp Motor kW Input	Sensible To Total Ratio (S/T) Dry Bulb			Total Cooling Capacity		Comp Motor kW Input	Sensible To Total Ratio (S/T) Dry Bulb			Total Cooling Capacity		Comp Motor kW Input	Sensible To Total Ratio (S/T) Dry Bulb		
			kW	kBtuh		24°C 75°F	27°C 80°F	29°C 85°F	kW	kBtuh		24°C 75°F	27°C 80°F	29°C 85°F	kW	kBtuh		24°C 75°F	27°C 80°F	29°C 85°F	kW	kBtuh		24°C 75°F	27°C 80°F	29°C 85°F
17°C (63°F)	2.64	5600	29.5	100.6	4.26	.68	.84	1.00	28.4	96.9	4.86	.69	.86	1.00	27.3	93.0	5.51	.70	.89	1.00	26.0	88.8	6.26	.72	.92	1.00
	3.30	7000	30.7	104.6	4.29	.74	.94	1.00	29.5	100.8	4.88	.76	.97	1.00	28.4	96.9	5.54	.78	.99	1.00	27.3	93.0	6.29	.81	1.00	1.00
	3.96	8400	31.8	108.5	4.32	.81	1.00	1.00	30.8	105.0	4.91	.84	1.00	1.00	29.7	101.2	5.57	.86	1.00	1.00	28.5	97.1	6.32	.89	1.00	1.00
19°C (67°F)	2.64	5600	31.3	106.8	4.31	.53	.66	.80	30.1	102.8	4.90	.54	.67	.82	28.9	98.7	5.56	.54	.68	.85	27.6	94.2	6.30	.55	.70	.87
	3.30	7000	32.3	110.2	4.34	.56	.72	.91	31.1	106.0	4.93	.57	.73	.93	29.8	101.6	5.58	.58	.75	.95	28.4	97.0	6.33	.60	.78	.98
	3.96	8400	33.0	112.7	4.36	.60	.79	.99	31.8	108.4	4.95	.61	.81	1.00	30.5	103.9	5.61	.62	.83	1.00	29.1	99.2	6.36	.64	.87	1.00
22°C (71°F)	2.64	5600	33.4	114.0	4.37	.39	.52	.64	32.1	109.7	4.96	.40	.52	.65	30.9	105.3	5.62	.40	.53	.66	29.5	100.5	6.37	.40	.54	.67
	3.30	7000	34.3	117.2	4.40	.41	.55	.70	33.0	112.7	4.99	.41	.56	.71	31.7	108.0	5.65	.41	.57	.73	30.2	103.1	6.39	.42	.58	.75
	3.96	8400	35.0	119.4	4.42	.42	.59	.76	33.6	114.8	5.01	.43	.60	.78	32.2	109.9	5.67	.43	.62	.81	30.7	104.9	6.42	.44	.63	.84

62 kW HIGH EFFICIENCY (R-410A) COOLING CAPACITY - ALL COMPRESSORS OPERATING

LGC210H4

Entering Wet Bulb Temperature	Total Air Volume		Outdoor Air Temperature Entering Outdoor Coil																							
			27°C (80°F)						35°C (95°F)						43°C (110°F)						52°C (125°F)					
			Total Cooling Capacity		Comp Motor kW Input	Sensible To Total Ratio (S/T) Dry Bulb			Total Cooling Capacity		Comp Motor kW Input	Sensible To Total Ratio (S/T) Dry Bulb			Total Cooling Capacity		Comp Motor kW Input	Sensible To Total Ratio (S/T) Dry Bulb			Total Cooling Capacity		Comp Motor kW Input	Sensible To Total Ratio (S/T) Dry Bulb		
			kW	kBtuh		24°C 75°F	27°C 80°F	29°C 85°F	kW	kBtuh		24°C 75°F	27°C 80°F	29°C 85°F	kW	kBtuh		24°C 75°F	27°C 80°F	29°C 85°F	kW	kBtuh		24°C 75°F	27°C 80°F	29°C 85°F
17°C (63°F)	2.64	5600	55.9	190.7	10.19	.76	.91	1.00	52.2	178.2	12.32	.79	.94	1.00	48.4	165.1	14.99	.82	.98	1.00	44.4	151.6	18.34	.86	1.00	1.00
	3.30	7000	58.2	198.6	10.24	.83	.98	1.00	54.7	186.6	12.37	.86	1.00	1.00	51.1	174.2	15.03	.89	1.00	1.00	47.1	160.8	18.41	.94	1.00	1.00
	3.96	8400	60.7	207.0	10.30	.89	1.00	1.00	57.1	195.0	12.44	.92	1.00	1.00	53.3	181.8	15.11	.96	1.00	1.00	49.1	167.6	18.46	.99	1.00	1.00
19°C (67°F)	2.64	5600	59.3	202.3	10.28	.59	.74	.88	55.4	189.0	12.40	.60	.76	.91	51.2	174.6	15.07	.62	.79	.95	46.6	159.1	18.42	.64	.83	.99
	3.30	7000	61.1	208.6	10.32	.63	.80	.96	57.0	194.6	12.46	.65	.83	.99	52.7	179.8	15.11	.67	.87	1.00	48.0	163.9	18.49	.70	.92	1.00
	3.96	8400	62.4	213.0	10.36	.67	.87	1.00	58.3	198.9	12.51	.69	.90	1.00	53.9	183.9	15.16	.72	.94	1.00	49.4	168.5	18.52	.76	.98	1.00
22°C (71°F)	2.64	5600	63.3	216.0	10.39	.43	.57	.71	59.1	201.7	12.52	.44	.59	.74	54.7	186.5	15.19	.45	.61	.77	49.9	170.2	18.56	.45	.63	.80
	3.30	7000	65.0	221.7	10.44	.45	.62	.78	60.6	206.9	12.58	.46	.64	.81	56.0	191.1	15.24	.47	.66	.85	51.1	174.2	18.60	.48	.69	.89
	3.96	8400	66.1	225.7	10.48	.47	.66	.85	61.7	210.5	12.63	.48	.69	.88	56.9	194.3	15.28	.49	.71	.92	51.9	177.1	18.65	.50	.75	.96

COOLING RATINGS

NOTE - For Temperatures and Capacities not shown in tables, see bulletin — Cooling Unit Rating Table Correction Factor Data in Miscellaneous Engineering Data section.

70 kW STANDARD EFFICIENCY COOLING CAPACITY - ONE COMPRESSOR OPERATING

LGC240S2

Entering Wet Bulb Temperature	Total Air Volume		Outdoor Air Temperature Entering Outdoor Coil																							
			18°C (65°F)						24°C (75°F)						29°C (85°F)						35°C (95°F)					
			Total Cooling Capacity		Comp Motor kW Input	Sensible To Total Ratio (S/T) Dry Bulb			Total Cooling Capacity		Comp Motor kW Input	Sensible To Total Ratio (S/T) Dry Bulb			Total Cooling Capacity		Comp Motor kW Input	Sensible To Total Ratio (S/T) Dry Bulb			Total Cooling Capacity		Comp Motor kW Input	Sensible To Total Ratio (S/T) Dry Bulb		
			kW	kBtuh		24°C 75°F	27°C 80°F	29°C 85°F	kW	kBtuh		24°C 75°F	27°C 80°F	29°C 85°F	kW	kBtuh		24°C 75°F	27°C 80°F	29°C 85°F	kW	kBtuh		24°C 75°F	27°C 80°F	29°C 85°F
17°C (63°F)	3.02	6400	31.9	108.8	6.00	.62	.80	.97	31.1	106.0	6.60	.63	.81	.98	30.1	102.6	7.28	.64	.83	1.00	29.0	99.0	8.04	.65	.86	1.00
	3.77	8000	33.0	112.6	6.08	.68	.90	1.00	32.2	109.8	6.66	.69	.92	1.00	31.2	106.4	7.34	.71	.94	1.00	30.1	102.6	8.12	.73	.96	1.00
	4.53	9600	33.9	115.8	6.14	.75	.98	1.00	33.2	113.2	6.72	.76	.99	1.00	32.2	109.8	7.42	.79	1.00	1.00	31.1	106.2	8.20	.81	1.00	1.00
19°C (67°F)	3.02	6400	33.8	115.2	6.14	.49	.60	.75	32.9	112.2	6.72	.49	.61	.77	31.8	108.6	7.40	.50	.62	.79	30.7	104.6	8.18	.50	.63	.81
	3.77	8000	34.6	118.2	6.20	.51	.65	.86	33.8	115.2	6.78	.52	.66	.87	32.7	111.6	7.46	.53	.68	.90	31.5	107.6	8.24	.53	.70	.92
	4.53	9600	35.3	120.6	6.24	.54	.72	.95	34.5	117.6	6.82	.55	.74	.96	33.4	113.8	7.50	.56	.76	.98	32.1	109.6	8.30	.57	.78	1.00
22°C (71°F)	3.02	6400	35.8	122.2	6.28	.36	.47	.58	34.9	119.2	6.86	.37	.48	.59	33.8	115.4	7.54	.37	.48	.60	32.6	111.4	8.34	.37	.49	.61
	3.77	8000	36.7	125.2	6.34	.37	.50	.63	35.8	122.0	6.92	.38	.51	.64	34.6	118.2	7.60	.38	.52	.65	33.4	114.0	8.38	.38	.52	.67
	4.53	9600	37.3	127.2	6.38	.39	.54	.69	36.4	124.2	6.96	.39	.54	.71	35.2	120.2	7.64	.39	.55	.73	33.9	115.8	8.44	.39	.56	.76

70 kW STANDARD EFFICIENCY COOLING CAPACITY - ALL COMPRESSORS OPERATING

LGC240S2

Entering Wet Bulb Temperature	Total Air Volume		Outdoor Air Temperature Entering Outdoor Coil																							
			27°C (80°F)						35°C (95°F)						43°C (110°F)						52°C (125°F)					
			Total Cooling Capacity		Comp Motor kW Input	Sensible To Total Ratio (S/T) Dry Bulb			Total Cooling Capacity		Comp Motor kW Input	Sensible To Total Ratio (S/T) Dry Bulb			Total Cooling Capacity		Comp Motor kW Input	Sensible To Total Ratio (S/T) Dry Bulb			Total Cooling Capacity		Comp Motor kW Input	Sensible To Total Ratio (S/T) Dry Bulb		
			kW	kBtuh		24°C 75°F	27°C 80°F	29°C 85°F	kW	kBtuh		24°C 75°F	27°C 80°F	29°C 85°F	kW	kBtuh		24°C 75°F	27°C 80°F	29°C 85°F	kW	kBtuh		24°C 75°F	27°C 80°F	29°C 85°F
17°C (63°F)	3.02	6400	63.0	214.8	14.16	.77	.88	1.00	59.7	203.8	16.48	.73	.91	1.00	56.2	191.8	19.28	.75	.94	1.00	52.9	180.4	22.68	.78	.98	1.00
	3.77	8000	65.2	222.6	14.32	.77	.97	1.00	61.9	211.2	16.64	.79	1.00	1.00	58.4	199.4	19.48	.83	1.00	1.00	55.2	188.2	22.92	.86	1.00	1.00
	4.53	9600	67.3	229.6	14.46	.84	1.00	1.00	64.1	218.6	16.80	.87	1.00	1.00	60.7	207.2	19.68	.90	1.00	1.00	57.3	195.4	23.14	.94	1.00	1.00
19°C (67°F)	3.02	6400	66.6	227.4	14.42	.55	.69	.84	63.1	215.4	16.74	.56	.71	.87	59.4	202.6	19.56	.58	.73	.90	55.7	190.0	23.00	.59	.75	.94
	3.77	8000	68.5	233.6	14.54	.59	.75	.93	64.9	221.4	16.86	.60	.77	.96	61.0	208.0	19.74	.61	.80	1.00	57.0	194.6	23.18	.63	.84	1.00
	4.53	9600	69.9	238.4	14.64	.62	.81	1.00	66.2	225.8	16.98	.63	.84	1.00	62.1	212.0	19.86	.65	.88	1.00	58.1	198.4	23.30	.68	.92	1.00
22°C (71°F)	3.02	6400	70.8	241.6	14.70	.41	.54	.67	67.2	229.2	17.06	.41	.55	.68	63.2	215.8	19.90	.42	.56	.70	59.2	202.0	23.38	.42	.58	.73
	3.77	8000	72.6	247.6	14.84	.42	.57	.73	68.8	234.8	17.16	.43	.59	.75	64.7	220.8	20.06	.43	.60	.77	60.4	206.2	23.56	.44	.63	.81
	4.53	9600	73.7	251.6	14.90	.44	.61	.79	69.9	238.6	17.26	.44	.63	.82	65.6	223.8	20.14	.45	.65	.85	61.4	209.4	23.62	.46	.67	.90

70 kW HIGH EFFICIENCY COOLING CAPACITY - ONE COMPRESSOR OPERATING

LGA240H2

Entering Wet Bulb Temperature	Total Air Volume		Outdoor Air Temperature Entering Outdoor Coil																							
			18°C (65°F)						24°C (75°F)						29°C (85°F)						35°C (95°F)					
			Total Cooling Capacity		Comp Motor kW Input	Sensible To Total Ratio (S/T) Dry Bulb			Total Cooling Capacity		Comp Motor kW Input	Sensible To Total Ratio (S/T) Dry Bulb			Total Cooling Capacity		Comp Motor kW Input	Sensible To Total Ratio (S/T) Dry Bulb			Total Cooling Capacity		Comp Motor kW Input	Sensible To Total Ratio (S/T) Dry Bulb		
			kW	kBtuh		24°C 75°F	27°C 80°F	29°C 85°F	kW	kBtuh		24°C 75°F	27°C 80°F	29°C 85°F	kW	kBtuh		24°C 75°F	27°C 80°F	29°C 85°F	kW	kBtuh		24°C 75°F	27°C 80°F	29°C 85°F
17°C (63°F)	3.02	6400	33.9	115.8	5.58	.65	.82	.98	32.9	112.4	6.26	.66	.84	1.00	31.8	108.6	7.06	.67	.86	1.00	30.7	104.6	7.98	.68	.88	1.00
	3.77	8000	35.3	120.4	5.62	.71	.92	1.00	34.2	116.8	6.32	.72	.94	1.00	33.1	112.8	7.12	.74	.96	1.00	31.9	108.8	8.04	.76	.98	1.00
	4.53	9600	36.5	124.4	5.66	.78	.99	1.00	35.4	120.8	6.36	.80	1.00	1.00	34.3	117.2	7.16	.82	1.00	1.00	33.2	113.2	8.10	.85	1.00	1.00
19°C (67°F)	3.02	6400	36.0	122.8	5.66	.51	.63	.77	34.9	119.2	6.34	.52	.64	.79	33.7	115.0	7.14	.52	.65	.81	32.5	110.8	8.06	.53	.66	.83
	3.77	8000	37.2	126.8	5.70	.54	.69	.88	36.0	122.8	6.40	.55	.70	.90	34.8	118.6	7.20	.56	.71	.92	33.4	114.0	8.12	.56	.74	.95
	4.53	9600	38.0	129.6	5.72	.57	.76	.97	36.8	125.4	6.42	.58	.78	.98	35.5	121.0	7.22	.59	.80	1.00	34.1	116.4	8.14	.60	.82	1.00
22°C (71°F)	3.02	6400	38.4	131.0	5.74	.38	.50	.61	37.2	127.0	6.44	.38	.50	.62	35.9	122.6	7.24	.38	.51	.63	34.6	118.0	8.16	.39	.51	.64
	3.77	8000	39.5	134.8	5.78	.39	.53	.66	38.2	130.4	6.48	.39	.54	.68	36.9	125.8	7.28	.40	.54	.69	35.5	121.0	8.22	.40	.55	.71
	4.53	9600	40.2	137.2	5.82	.40	.56	.73	38.9	132.8	6.52	.41	.57	.75	37.5	128.0	7.32	.41	.58	.77	36.0	123.0	8.24	.42	.59	.79

70 kW HIGH EFFICIENCY COOLING CAPACITY - ALL COMPRESSORS OPERATING

LGA240H2

Entering Wet Bulb Temperature	Total Air Volume		Outdoor Air Temperature Entering Outdoor Coil																							
			27°C (80°F)						35°C (95°F)						43°C (110°F)						52°C (125°F)					
			Total Cooling Capacity		Comp Motor kW Input	Sensible To Total Ratio (S/T) Dry Bulb			Total Cooling Capacity		Comp Motor kW Input	Sensible To Total Ratio (S/T) Dry Bulb			Total Cooling Capacity		Comp Motor kW Input	Sensible To Total Ratio (S/T) Dry Bulb			Total Cooling Capacity		Comp Motor kW Input	Sensible To Total Ratio (S/T) Dry Bulb		
			kW	kBtuh		24°C 75°F	27°C 80°F	29°C 85°F	kW	kBtuh		24°C 75°F	27°C 80°F	29°C 85°F	kW	kBtuh		24°C 75°F	27°C 80°F	29°C 85°F	kW	kBtuh		24°C 75°F	27°C 80°F	29°C 85°F
17°C (63°F)	3.02	6400	64.9	221.6	13.16	.78	.88	1.00	61.5	209.8	15.80	.73	.91	1.00	57.7	197.0	19.02	.76	.94	1.00	53.9	183.8	22.91	.79	.98	1.00
	3.77	8000	67.5	230.2	13.27	.78	.97	1.00	63.9	218.2	15.92	.80	1.00	1.00	60.4	206.2	19.13	.84	1.00	1.00	56.7	193.4	23.06	.88	1.00	1.00
	4.53	9600	70.0	238.8	13.36	.85	1.00	1.00	66.6	227.2	16.04	.88	1.00	1.00	62.9	214.6	19.26	.92	1.00	1.00	59.0	201.4	23.18	.96	1.00	1.00
19°C (67°F)	3.02	6400	68.9	235.0	13.32	.56	.69	.84	65.1	222.2	15.97	.57	.71	.87	61.0	208.2	19.22	.58	.73	.90	56.8	193.8	23.09	.60	.76	.95
	3.77	8000	70.9	242.0	13.42	.59	.76	.93	67.0	228.7	16.08	.61	.78	.97	62.8	214.2	19.30	.62	.81	1.00	58.3	199.0	23.20	.64	.85	1.00
	4.53	9600	72.4	247.2	13.48	.63	.82	1.00	68.4	233.4	16.12	.65	.86	1.00	64.1	218.7	19.38	.67	.89	1.00	59.6	203.4	23.28	.69	.94	1.00
22°C (71°F)	3.02	6400	73.4	250.4	13.52	.41	.54	.67	69.4	236.8	16.16	.42	.55	.69	65.0	221.9	19.44	.42	.57	.71	60.5	206.3	23.33	.43	.58	.74
	3.77	8000	75.3	257.1	13.62	.43	.58	.73	71.2	242.8	16.28	.43	.60	.76	66.6	227.2	19.52	.44	.61	.79	61.9	211.1	23.42	.45	.64	.83
	4.53	9600	76.7	261.6	13.66	.44	.62	.80	72.3	246.8	16.32	.45	.64	.83	67.7	230.9	19.58	.46	.66	.87	62.8	214.3	23.50	.47	.69	.92

COOLING RATINGS

NOTE - For Temperatures and Capacities not shown in tables, see bulletin — Cooling Unit Rating Table Correction Factor Data in Miscellaneous Engineering Data section.

70 kW HIGH EFFICIENCY (R-410A) COOLING CAPACITY - ONE COMPRESSOR OPERATING

LGA240H4

Entering Wet Bulb Temperature	Total Air Volume		Outdoor Air Temperature Entering Outdoor Coil																							
			18°C (65°F)						24°C (75°F)						29°C (85°F)						35°C (95°F)					
			Total Cooling Capacity		Comp Motor kW Input	Sensible To Total Ratio (S/T) Dry Bulb			Total Cooling Capacity		Comp Motor kW Input	Sensible To Total Ratio (S/T) Dry Bulb			Total Cooling Capacity		Comp Motor kW Input	Sensible To Total Ratio (S/T) Dry Bulb			Total Cooling Capacity		Comp Motor kW Input	Sensible To Total Ratio (S/T) Dry Bulb		
			kW	kBtuh		24°C 75°F	27°C 80°F	29°C 85°F	kW	kBtuh		24°C 75°F	27°C 80°F	29°C 85°F	kW	kBtuh		24°C 75°F	27°C 80°F	29°C 85°F	kW	kBtuh		24°C 75°F	27°C 80°F	29°C 85°F
17°C (63°F)	3.02	6400	33.4	114.0	4.90	.64	.81	.97	32.2	109.9	5.58	.66	.83	.99	30.9	105.4	6.34	.67	.86	1.00	29.5	100.6	7.22	.68	.89	1.00
	3.77	8000	34.8	118.6	4.95	.70	.92	1.00	33.5	114.2	5.63	.72	.94	1.00	32.1	109.7	6.40	.74	.96	1.00	30.7	104.9	7.28	.77	.98	1.00
	4.53	9600	35.9	122.6	4.99	.78	.98	1.00	34.6	118.2	5.68	.80	.99	1.00	33.4	113.8	6.46	.83	1.00	1.00	32.0	109.1	7.34	.86	1.00	1.00
19°C (67°F)	3.02	6400	35.4	120.9	4.97	.50	.62	.76	34.1	116.3	5.66	.51	.63	.79	32.7	111.5	6.43	.52	.65	.81	31.2	106.4	7.31	.53	.66	.84
	3.77	8000	36.5	124.6	5.02	.53	.68	.87	35.1	119.8	5.71	.54	.69	.90	33.6	114.7	6.48	.55	.71	.93	32.1	109.4	7.35	.56	.74	.96
	4.53	9600	37.3	127.4	5.05	.57	.75	.96	35.8	122.3	5.75	.58	.77	.98	34.3	117.1	6.51	.59	.80	.99	32.7	111.6	7.39	.60	.83	1.00
22°C (71°F)	3.02	6400	37.7	128.6	5.07	.38	.49	.60	36.3	123.7	5.77	.38	.50	.61	34.7	118.4	6.54	.38	.50	.62	33.1	112.9	7.42	.39	.51	.64
	3.77	8000	38.7	132.2	5.11	.39	.52	.66	37.2	126.9	5.81	.39	.53	.67	35.6	121.5	6.59	.39	.54	.69	33.9	115.7	7.46	.40	.55	.71
	4.53	9600	39.4	134.6	5.15	.40	.56	.72	37.9	129.2	5.85	.41	.57	.75	36.2	123.5	6.62	.41	.58	.77	34.4	117.5	7.50	.42	.60	.81

70 kW HIGH EFFICIENCY (R-410A) COOLING CAPACITY - ALL COMPRESSORS OPERATING

LGA240H4

Entering Wet Bulb Temperature	Total Air Volume		Outdoor Air Temperature Entering Outdoor Coil																							
			27°C (80°F)						35°C (95°F)						43°C (110°F)						52°C (125°F)					
			Total Cooling Capacity		Comp Motor kW Input	Sensible To Total Ratio (S/T) Dry Bulb			Total Cooling Capacity		Comp Motor kW Input	Sensible To Total Ratio (S/T) Dry Bulb			Total Cooling Capacity		Comp Motor kW Input	Sensible To Total Ratio (S/T) Dry Bulb			Total Cooling Capacity		Comp Motor kW Input	Sensible To Total Ratio (S/T) Dry Bulb		
			kW	kBtuh		24°C 75°F	27°C 80°F	29°C 85°F	kW	kBtuh		24°C 75°F	27°C 80°F	29°C 85°F	kW	kBtuh		24°C 75°F	27°C 80°F	29°C 85°F	kW	kBtuh		24°C 75°F	27°C 80°F	29°C 85°F
17°C (63°F)	3.02	6400	63.5	216.6	11.89	.74	.90	1.00	59.3	202.4	14.42	.76	.93	1.00	54.8	187.0	17.57	.79	.97	1.00	50.0	170.6	21.50	.84	.99	1.00
	3.77	8000	66.0	225.3	11.99	.80	.98	1.00	61.9	211.3	14.54	.83	.99	1.00	57.5	196.1	17.70	.88	1.00	1.00	52.5	179.2	21.65	.93	1.00	1.00
	4.53	9600	68.5	233.8	12.13	.87	1.00	1.00	64.4	219.7	14.69	.91	1.00	1.00	59.8	203.9	17.84	.95	1.00	1.00	54.5	185.8	21.78	.99	1.00	1.00
19°C (67°F)	3.02	6400	67.1	228.9	12.07	.57	.72	.86	62.6	213.6	14.59	.59	.74	.90	57.6	196.6	17.74	.60	.77	.94	51.9	177.2	21.65	.63	.81	.99
	3.77	8000	69.0	235.4	12.16	.61	.78	.95	64.3	219.4	14.70	.63	.81	.98	59.1	201.5	17.82	.65	.86	1.00	53.3	181.9	21.75	.69	.91	1.00
	4.53	9600	70.4	240.1	12.22	.65	.85	.99	65.6	223.8	14.78	.68	.89	1.00	60.3	205.8	17.90	.70	.93	1.00	54.6	186.2	21.84	.74	.98	1.00
22°C (71°F)	3.02	6400	71.2	243.1	12.27	.42	.56	.69	66.4	226.5	14.82	.43	.57	.72	61.0	208.3	17.94	.43	.59	.75	55.0	187.8	21.86	.44	.62	.79
	3.77	8000	73.0	249.2	12.36	.44	.60	.76	67.9	231.8	14.91	.44	.62	.79	62.3	212.7	18.05	.45	.65	.83	56.2	191.6	21.94	.47	.68	.89
	4.53	9600	74.2	253.1	12.43	.45	.65	.83	69.0	235.4	14.97	.46	.67	.87	63.2	215.7	18.11	.48	.70	.92	56.9	194.1	22.02	.50	.74	.97

88 kW STANDARD EFFICIENCY COOLING CAPACITY - ONE COMPRESSOR OPERATING

LGC300S2

Entering Wet Bulb Temperature	Total Air Volume		Outdoor Air Temperature Entering Outdoor Coil																							
			18°C (65°F)						24°C (75°F)						29°C (85°F)						35°C (95°F)					
			Total Cooling Capacity		Comp Motor kW Input	Sensible To Total Ratio (S/T) Dry Bulb			Total Cooling Capacity		Comp Motor kW Input	Sensible To Total Ratio (S/T) Dry Bulb			Total Cooling Capacity		Comp Motor kW Input	Sensible To Total Ratio (S/T) Dry Bulb			Total Cooling Capacity		Comp Motor kW Input	Sensible To Total Ratio (S/T) Dry Bulb		
			kW	kBtuh		24°C 75°F	27°C 80°F	29°C 85°F	kW	kBtuh		24°C 75°F	27°C 80°F	29°C 85°F	kW	kBtuh		24°C 75°F	27°C 80°F	29°C 85°F	kW	kBtuh		24°C 75°F	27°C 80°F	29°C 85°F
17°C (63°F)	3.77	8000	40.0	136.4	7.46	.63	.80	.99	38.7	132.2	8.30	.64	.82	1.00	37.5	127.8	9.26	.65	.85	1.00	36.2	123.4	10.36	.66	.87	1.00
	4.72	10000	41.5	141.6	7.58	.68	.91	1.00	40.2	137.2	8.42	.70	.94	1.00	38.9	132.8	9.38	.72	.96	1.00	37.6	128.2	10.48	.74	.98	1.00
	5.66	12000	42.8	146.0	7.68	.76	.99	1.00	41.6	141.8	8.54	.78	1.00	1.00	40.3	137.4	9.50	.81	1.00	1.00	38.9	132.8	10.62	.83	1.00	1.00
19°C (67°F)	3.77	8000	42.3	144.2	7.64	.49	.61	.76	40.9	139.6	8.50	.50	.62	.78	39.6	135.0	9.46	.50	.63	.80	38.1	130.0	10.54	.51	.64	.83
	4.72	10000	43.4	148.2	7.74	.52	.66	.87	42.1	143.6	8.58	.53	.67	.90	40.6	138.6	9.56	.54	.69	.92	39.1	133.4	10.66	.54	.71	.95
	5.66	12000	44.4	151.4	7.82	.55	.73	.97	42.9	146.4	8.66	.56	.76	.98	41.4	141.4	9.64	.57	.78	1.00	39.9	136.0	10.74	.58	.81	1.00
22°C (71°F)	3.77	8000	44.8	153.0	7.86	.37	.48	.59	43.4	148.2	8.70	.37	.48	.60	42.0	143.2	9.68	.37	.49	.61	40.4	137.8	10.78	.37	.50	.62
	4.72	10000	46.0	157.0	7.96	.38	.51	.64	44.5	152.0	8.80	.38	.52	.65	43.0	146.8	9.78	.38	.52	.67	41.4	141.2	10.88	.39	.53	.69
	5.66	12000	46.8	159.6	8.04	.39	.54	.71	45.3	154.4	8.88	.39	.55	.73	43.7	149.0	9.84	.40	.56	.75	42.0	143.2	10.94	.40	.57	.78

88 kW STANDARD EFFICIENCY COOLING CAPACITY - ALL COMPRESSORS OPERATING

LGC300S2

Entering Wet Bulb Temperature	Total Air Volume		Outdoor Air Temperature Entering Outdoor Coil																							
			27°C (80°F)						35°C (95°F)						43°C (110°F)						52°C (125°F)					
			Total Cooling Capacity		Comp Motor kW Input	Sensible To Total Ratio (S/T) Dry Bulb			Total Cooling Capacity		Comp Motor kW Input	Sensible To Total Ratio (S/T) Dry Bulb			Total Cooling Capacity		Comp Motor kW Input	Sensible To Total Ratio (S/T) Dry Bulb			Total Cooling Capacity		Comp Motor kW Input	Sensible To Total Ratio (S/T) Dry Bulb		
			kW	kBtuh		24°C 75°F	27°C 80°F	29°C 85°F	kW	kBtuh		24°C 75°F	27°C 80°F	29°C 85°F	kW	kBtuh		24°C 75°F	27°C 80°F	29°C 85°F	kW	kBtuh		24°C 75°F	27°C 80°F	29°C 85°F
17°C (63°F)	3.77	8000	79.6	271.5	17.84	.72	.89	1.00	75.5	257.5	20.86	.74	.92	1.00	70.8	241.7	24.76	.76	.96	1.00	65.8	224.6	29.44	.79	1.00	1.00
	4.72	10000	82.5	281.5	17.88	.78	.98	1.00	78.3	267.2	21.10	.81	1.00	1.00	73.9	252.1	25.06	.84	1.00	1.00	69.1	235.7	29.79	.89	1.00	1.00
	5.66	12000	85.3	291.1	18.12	.85	1.00	1.00	81.2	277.1	21.38	.89	1.00	1.00	76.7	261.7	25.34	.93	1.00	1.00	71.7	244.6	30.08	.97	1.00	1.00
19°C (67°F)	3.77	8000	84.0	286.5	18.04	.56	.70	.85	79.5	271.3	21.24	.57	.72	.88	74.5	254.3	25.16	.58	.74	.92	69.0	235.5	29.85	.60	.77	.97
	4.72	10000	86.3	294.5	18.20	.60	.76	.95	81.6	278.5	21.46	.61	.78	.98	76.5	261.1	25.38	.63	.82	1.00	70.8	241.7	30.06	.65	.86	1.00
	5.66	12000	88.0	300.3	18.40	.63	.83	1.00	83.2	283.9	21.62	.65	.86	1.00	78.0	266.1	25.53	.67	.91	1.00	72.4	246.9	30.23	.70	.95	1.00
22°C (71°F)	3.77	8000	89.1	304.1	18.48	.41	.55	.68	84.4	288.0	21.69	.42	.56	.69	79.2	270.3	25.64	.42	.57	.72	73.4	250.3	30.34	.43	.59	.75
	4.72	10000	91.4	311.7	18.67	.43	.58	.74	86.4	294.7	21.92	.43	.60	.76	80.9	276.1	25.82	.44	.62	.79	74.9	255.5	30.54	.45	.64	.84
	5.66	12000	92.8	316.7	18.83	.44	.63	.81	87.6	299.0	22.04	.45	.64	.84	82.1	280.1	25.97	.46	.67	.88	75.9	259.1	30.70	.47	.69	.93

COOLING RATINGS

NOTE - For Temperatures and Capacities not shown in tables, see bulletin — Cooling Unit Rating Table Correction Factor Data in Miscellaneous Engineering Data section.

88 kW STANDARD EFFICIENCY (R-410A) COOLING CAPACITY - ONE COMPRESSOR OPERATING

LGC300S4

Entering Wet Bulb Temperature	Total Air Volume		Outdoor Air Temperature Entering Outdoor Coil																							
			18°C (65°F)						24°C (75°F)						29°C (85°F)						35°C (95°F)					
			Total Cooling Capacity		Comp Motor kW Input	Sensible To Total Ratio (S/T) Dry Bulb			Total Cooling Capacity		Comp Motor kW Input	Sensible To Total Ratio (S/T) Dry Bulb			Total Cooling Capacity		Comp Motor kW Input	Sensible To Total Ratio (S/T) Dry Bulb			Total Cooling Capacity		Comp Motor kW Input	Sensible To Total Ratio (S/T) Dry Bulb		
			kW	kBtuh		24°C 75°F	27°C 80°F	29°C 85°F	kW	kBtuh		24°C 75°F	27°C 80°F	29°C 85°F	kW	kBtuh		24°C 75°F	27°C 80°F	29°C 85°F	kW	kBtuh		24°C 75°F	27°C 80°F	29°C 85°F
17°C (63°F)	3.77	8000	39.5	134.8	7.24	.63	.81	.99	38.0	129.6	8.08	.64	.84	1.00	36.4	124.2	9.02	.66	.86	1.00	34.6	118.0	10.12	.67	.90	1.00
4.72	10000	41.0	139.8	7.34	.68	.92	1.00	39.4	134.6	8.18	.71	.95	1.00	37.8	129.0	9.14	.74	.98	1.00	36.0	123.0	10.24	.77	1.00	1.00	
5.66	12000	42.3	144.2	7.44	.77	1.00	1.00	40.8	139.2	8.28	.79	1.00	1.00	39.2	133.8	9.26	.83	1.00	1.00	37.5	127.8	10.36	.87	1.00	1.00	
19°C (67°F)	3.77	8000	41.7	142.4	7.40	.49	.61	.76	40.1	136.8	8.24	.50	.62	.79	38.3	130.8	9.20	.51	.64	.82	36.5	124.4	10.30	.51	.65	.86
4.72	10000	43.0	146.6	7.48	.52	.66	.88	41.2	140.6	8.34	.53	.68	.91	39.4	134.4	9.30	.54	.70	.94	37.4	127.6	10.38	.55	.74	.98	
5.66	12000	43.8	149.4	7.56	.55	.74	.97	42.0	143.4	8.40	.56	.77	.99	40.2	137.0	9.36	.58	.80	1.00	38.2	130.2	10.44	.59	.84	1.00	
22°C (71°F)	3.77	8000	44.3	151.2	7.58	.37	.48	.59	42.6	145.4	8.44	.37	.49	.60	40.7	139.0	9.40	.37	.49	.62	38.7	132.0	10.50	.37	.50	.63
4.72	10000	45.4	155.0	7.68	.38	.51	.65	43.7	149.0	8.52	.38	.52	.66	41.7	142.2	9.50	.38	.53	.68	39.6	135.0	10.58	.39	.55	.71	
5.66	12000	46.2	157.6	7.74	.39	.55	.71	44.3	151.2	8.58	.39	.56	.74	42.3	144.4	9.54	.40	.57	.77	40.2	137.0	10.64	.41	.59	.81	

88 kW STANDARD EFFICIENCY (R-410A) COOLING CAPACITY - ONE COMPRESSOR OPERATING

LGC300S4

Entering Wet Bulb Temperature	Total Air Volume		Outdoor Air Temperature Entering Outdoor Coil																							
			27°C (80°F)						35°C (95°F)						43°C (110°F)						52°C (125°F)					
			Total Cooling Capacity		Comp Motor kW Input	Sensible To Total Ratio (S/T) Dry Bulb			Total Cooling Capacity		Comp Motor kW Input	Sensible To Total Ratio (S/T) Dry Bulb			Total Cooling Capacity		Comp Motor kW Input	Sensible To Total Ratio (S/T) Dry Bulb			Total Cooling Capacity		Comp Motor kW Input	Sensible To Total Ratio (S/T) Dry Bulb		
			kW	kBtuh		24°C 75°F	27°C 80°F	29°C 85°F	kW	kBtuh		24°C 75°F	27°C 80°F	29°C 85°F	kW	kBtuh		24°C 75°F	27°C 80°F	29°C 85°F	kW	kBtuh		24°C 75°F	27°C 80°F	29°C 85°F
17°C (63°F)	3.77	8000	77.6	264.9	17.20	.73	.90	1.00	72.2	246.5	20.39	.75	.94	1.00	66.3	226.3	24.33	.79	1.00	1.00	60.2	205.3	29.17	.84	1.00	1.00
4.72	10000	80.6	274.9	17.41	.79	1.00	1.00	75.2	256.7	20.65	.83	1.00	1.00	69.5	237.3	24.63	.88	1.00	1.00	63.2	215.7	29.50	.95	1.00	1.00	
5.66	12000	83.4	284.7	17.65	.86	1.00	1.00	78.2	266.7	20.89	.91	1.00	1.00	72.2	246.3	24.87	.97	1.00	1.00	65.4	223.3	29.74	1.00	1.00	1.00	
19°C (67°F)	3.77	8000	81.9	279.5	17.54	.56	.71	.86	76.1	259.7	20.75	.58	.73	.90	69.6	237.6	24.65	.60	.77	.96	62.4	213.0	29.47	.63	.81	1.00
4.72	10000	84.1	287.1	17.73	.60	.77	.96	78.1	266.5	20.93	.62	.80	1.00	71.4	243.6	24.85	.65	.85	1.00	64.0	218.5	29.67	.68	.93	1.00	
5.66	12000	85.8	292.8	17.87	.64	.84	1.00	79.7	271.8	21.05	.66	.89	1.00	72.9	248.8	25.00	.70	.95	1.00	65.6	223.7	29.84	.74	1.00	1.00	
22°C (71°F)	3.77	8000	87.0	296.7	17.94	.42	.55	.68	80.8	275.8	21.15	.42	.57	.71	73.9	252.3	25.09	.43	.59	.74	66.3	226.1	29.92	.44	.62	.79
4.72	10000	89.0	303.8	18.11	.43	.59	.75	82.6	282.0	21.33	.44	.61	.78	75.4	257.4	25.25	.45	.64	.83	67.5	230.4	30.08	.46	.68	.90	
5.66	12000	90.4	308.5	18.23	.45	.63	.82	83.9	286.2	21.45	.46	.66	.86	76.5	261.2	25.37	.47	.69	.92	68.4	233.4	30.20	.49	.73	1.00	

BLOWER DATA

FACTORY INSTALLED BELT DRIVE KIT SPECIFICATIONS

Model No.	Motor Efficiency	Nominal kW	Maximum kW	Nominal hp	Maximum hp	Drive Kit Number	Rev/Min Range
156H	Standard	1.5	1.7	2 hp	2.3	A	446 - 604
156H thru 210	Standard	2.2	2.6	3 hp	3.45	2	571 - 721
156H thru 300S	Standard	3.7	4.3	5 hp	5.75	2 3 4	571 - 721 708 - 871 788 - 988
180 thru 300S	Standard	5.6	6.4	7.5 hp	8.63	5 6 7	788 - 988 871 - 1071 708 - 871
240 thru 300S	Standard	7.5	8.6	10 hp	11.5	6 8	871 - 1071 945 - 1138

BLOWER DATA

BLOWER TABLE INCLUDES RESISTANCE FOR BASE UNIT WITH STANDARD GAS HEAT, WET INDOOR COIL & AIR FILTERS IN PLACE.

FOR ALL UNITS ADD:

1 - Any factory installed options air resistance (high gas heat, economizer, etc.). See table below

2 - Any field installed accessories air resistance (duct resistance, diffuser, etc.). See page 28

Then determine from table the blower motor output and drive required.

75 to 225 Pa

LGC156

Air Volume L/s		External Static - Pa (in. w.g.)																				
		75 (0.30)			100 (0.40)			125 (0.50)			150 (0.60)			175 (0.70)			200 (0.80)			225 (0.90)		
rev/min	kW	BHP	rev/min	kW	BHP	rev/min	kW	BHP	rev/min	kW	BHP	rev/min	kW	BHP	rev/min	kW	BHP	rev/min	kW	BHP		
L/s	cfm	Low Static - 1.5 kW (2 HP)						Standard Static - 2.2 kW (3 HP)						Standard Static - 3.7 kW (5 HP)								
1965	4160	551	0.67	0.90	596	0.78	1.04	641	0.88	1.18	681	0.99	1.33	720	1.10	1.48	755	1.22	1.64	790	1.34	1.80
2075	4400	561	0.72	0.97	606	0.85	1.14	651	0.97	1.30	689	1.08	1.45	727	1.19	1.60	762	1.32	1.77	797	1.45	1.94
2265	4800	577	0.84	1.13	620	0.98	1.31	662	1.10	1.48	702	1.24	1.66	742	1.37	1.83	777	1.50	2.01	811	1.63	2.18
2455	5200	593	0.99	1.33	636	1.13	1.51	678	1.25	1.68	716	1.40	1.88	754	1.54	2.07	789	1.69	2.27	823	1.84	2.46
2640	5600	609	1.13	1.51	652	1.28	1.71	694	1.42	1.91	732	1.58	2.12	769	1.74	2.33	803	1.89	2.53	837	2.04	2.73
2830	6000	630	1.31	1.75	670	1.45	1.95	710	1.60	2.15	748	1.78	2.38	785	1.94	2.60	818	2.11	2.83	850	2.28	3.05
2945	6240	640	1.41	1.89	680	1.58	2.12	720	1.75	2.34	757	1.92	2.57	795	2.08	2.79	827	2.25	3.02	860	2.42	3.24

250 to 425 Pa

LGC156

Air Volume L/s		External Static - Pa (in. w.g.)																							
		250 (1.00)			275 (1.10)			300 (1.20)			325 (1.30)			350 (1.40)			375 (1.50)			400 (1.60)			425 (1.70)		
rev/min	kW	BHP	rev/min	kW	BHP	rev/min	kW	BHP	rev/min	kW	BHP	rev/min	kW	BHP	rev/min	kW	BHP	rev/min	kW	BHP	rev/min	kW	BHP		
L/s	cfm	Standard Static - 3.7 kW (5 HP)												Field Furnished											
1965	4160	822	1.45	1.95	855	1.57	2.11	885	1.69	2.26	915	1.80	2.41	942	1.92	2.57	970	2.04	2.73	997	2.15	2.88	1023	2.26	3.03
2075	4400	830	1.57	2.11	862	1.70	2.28	892	1.81	2.43	922	1.92	2.58	950	2.05	2.75	977	2.18	2.92	1003	2.29	3.07	1028	2.40	3.22
2265	4800	842	1.76	2.36	872	1.89	2.54	902	2.03	2.72	932	2.16	2.89	960	2.29	3.07	987	2.42	3.24	1014	2.55	3.42	1041	2.69	3.60
2455	5200	856	1.98	2.66	888	2.13	2.86	916	2.27	3.04	944	2.39	3.21	972	2.54	3.41	999	2.69	3.60	1024	2.82	3.78	1049	2.95	3.96
2640	5600	868	2.19	2.93	899	2.33	3.13	928	2.48	3.33	957	2.63	3.53	985	2.79	3.74	1012	2.95	3.95	1037	3.10	4.15	1062	3.25	4.35
2830	6000	880	2.42	3.25	910	2.57	3.45	940	2.75	3.68	970	2.91	3.90	998	3.08	4.13	1025	3.25	4.35	1050	3.42	4.58	1075	3.58	4.80
2945	6240	890	2.59	3.47	920	2.75	3.69	947	2.92	3.92	975	3.09	4.14	1002	3.26	4.37	1030	3.42	4.59	1055	3.60	4.82	1080	3.76	5.04

450 to 625 Pa

LGC156

Air Volume L/s		External Static - Pa (in. w.g.)																							
		450 (1.80)			475 (1.90)			500 (2.00)			525 (2.10)			550 (2.20)			570 (2.30)			600 (2.40)			625 (2.50)		
rev/min	kW	BHP	rev/min	kW	BHP	rev/min	kW	BHP	rev/min	kW	BHP	rev/min	kW	BHP	rev/min	kW	BHP	rev/min	kW	BHP	rev/min	kW	BHP		
L/s	cfm	Field Furnished																							
1965	4160	1048	2.39	3.20	1073	2.52	3.38	1097	2.64	3.54	1120	2.77	3.71	1142	2.88	3.86	1165	2.99	4.01	1187	3.11	4.17	1208	3.23	4.33
2075	4400	1053	2.54	3.40	1078	2.66	3.57	1103	2.80	3.76	1127	2.95	3.95	1150	3.06	4.10	1172	3.17	4.25	1193	3.30	4.42	1213	3.42	4.59
2265	4800	1064	2.82	3.78	1087	2.95	3.95	1112	3.08	4.13	1136	3.21	4.30	1159	3.36	4.50	1181	3.51	4.70	1204	3.64	4.88	1226	3.77	5.06
2455	5200	1074	3.10	4.16	1099	3.25	4.35	1124	3.39	4.55	1148	3.54	4.74	1171	3.69	4.94	1193	3.83	5.14	1214	3.98	5.34	1234	4.13	5.54
2640	5600	1087	3.41	4.57	1112	3.58	4.80	1135	3.73	5.00	1157	3.88	5.2	1180	4.04	5.41	1202	4.19	5.62	1223	4.35	5.83	1244	4.51	6.04
2830	6000	1098	3.73	5.00	1120	3.88	5.20	1145	4.05	5.43	1170	4.21	5.65	1193	4.39	5.88	1215	4.55	6.10	1235	4.72	6.33	1255	4.89	6.55
2945	6240	1105	3.92	5.26	1130	4.10	5.49	1152	4.26	5.71	1175	4.43	5.94	1197	4.62	6.19	1220	4.80	6.44	1242	4.97	6.66	1265	5.14	6.89

AIR RESISTANCE - Factory Installed Options

Air Volume L/s cfm		Gas Heat Exchanger				Economizer		Horizontal Roof Curb		Filters			
		Medium Heat		High Heat						MERV 11		MERV 15	
L/s	cfm	Pa	in. w.g.	Pa	in. w.g.	Pa	in. w.g.	Pa	in. w.g.	Pa	in. w.g.	Pa	in. w.g.
1965	4160	5.0	0.02	---	---	---	---	17.4	0.07	2.5	0.01	5.0	0.02
2075	4400	5.0	0.02	909	0.04	---	---	17.4	0.07	2.5	0.01	5.0	0.02
2265	4800	7.5	0.03	12.4	0.05	---	---	19.9	0.08	2.5	0.01	5.0	0.02
2455	5000	9.9	0.04	14.9	0.06	---	---	19.9	0.08	2.5	0.01	5.0	0.02
2640	5600	9.9	0.04	17.4	0.07	---	---	24.9	0.10	5.0	0.02	5.0	0.02
2830	6000	12.4	0.05	19.9	0.08	---	---	27.3	0.11	5.0	0.02	7.5	0.03
2945	6240	12.4	0.05	22.4	0.09	2.5	0.01	29.8	0.12	5.0	0.02	7.5	0.03

BLOWER DATA

BLOWER TABLE INCLUDES RESISTANCE FOR BASE UNIT WITH STANDARD GAS HEAT, WET INDOOR COIL & AIR FILTERS IN PLACE.

FOR ALL UNITS ADD:

1 - Any factory installed options air resistance (high gas heat, economizer, etc.). See table below

2 - Any field installed accessories air resistance (duct resistance, diffuser, etc.). See page 28

Then determine from table the blower motor output and drive required.

75 to 250 Pa

LGC180

Air Volume	External Static - Pa (in. w.g.)																										
	75 (0.30)			100 (0.40)			125 (0.50)			150 (0.60)			175 (0.70)			200 (0.80)			225 (0.90)			250 (1.00)					
	rev/min	kW	BHP	rev/min	kW	BHP	rev/min	kW	BHP	rev/min	kW	BHP	rev/min	kW	BHP	rev/min	kW	BHP	rev/min	kW	BHP	rev/min	kW	BHP			
L/s cfm	Low Static - 2.2 kW (3 HP)												Standard Static - 3.7 kW (5 HP)														
2265 4800	577	0.84	1.13	620	0.98	1.31	662	1.10	1.48	702	1.24	1.66	742	1.37	1.83	777	1.50	2.01	811	1.63	2.18	842	1.76	2.36			
2360 5000	585	0.93	1.25	628	1.07	1.43	670	1.19	1.60	710	1.33	1.78	750	1.45	1.95	783	1.59	2.13	815	1.72	2.30	848	1.87	2.50			
2595 5500	605	1.08	1.45	648	1.23	1.65	690	1.38	1.85	728	1.53	2.05	765	1.68	2.25	800	1.83	2.45	835	1.98	2.65	865	2.13	2.85			
2830 6000	630	1.31	1.75	670	1.45	1.95	710	1.60	2.15	748	1.78	2.38	785	1.94	2.60	818	2.11	2.83	850	2.28	3.05	880	2.42	3.25			
3065 6500	650	1.53	2.05	690	1.70	2.28	730	1.87	2.50	768	2.05	2.75	805	2.24	3.00	838	2.41	3.23	870	2.57	3.45	900	2.76	3.70			
3305 7000	675	1.75	2.35	715	1.96	2.63	755	2.16	2.90	790	2.35	3.15	825	2.54	3.40	858	2.75	3.68	890	2.95	3.95	920	3.13	4.20			
3400 7200	687	1.90	2.55	725	2.10	2.81	763	2.28	3.06	798	2.48	3.33	833	2.69	3.60	866	2.88	3.86	898	3.07	4.11	926	3.25	4.36			

275 to 425 Pa

LGC180

Air Volume	External Static - Pa (in. w.g.)																										
	275 (1.10)			300 (1.20)			325 (1.30)			350 (1.40)			375 (1.50)			400 (1.60)			425 (1.70)			450 (1.80)					
	rev/min	kW	BHP	rev/min	kW	BHP	rev/min	kW	BHP	rev/min	kW	BHP	rev/min	kW	BHP	rev/min	kW	BHP	rev/min	kW	BHP	rev/min	kW	BHP			
L/s cfm	Standard Static - 3.7 kW (5 HP)												High Static - 5.6 kW (7.5 HP)														
2265 4800	872	1.89	2.54	902	2.03	2.72	932	2.16	2.89	960	2.29	3.07	987	2.42	3.24	1014	2.55	3.42	1041	2.69	3.60	1064	2.82	3.78			
2360 5000	880	2.01	2.70	910	2.15	2.88	940	2.28	3.05	968	2.41	3.23	995	2.54	3.40	1020	2.69	3.60	1045	2.83	3.80	1070	2.97	3.98			
2595 5500	895	2.28	3.05	925	2.42	3.25	955	2.57	3.45	983	2.72	3.65	1010	2.87	3.85	1035	3.02	4.05	1060	3.17	4.25	1085	3.34	4.48			
2830 6000	910	2.57	3.45	940	2.75	3.68	970	2.91	3.90	998	3.08	4.13	1025	3.25	4.35	1050	3.42	4.58	1075	3.58	4.80	1098	3.73	5.00			
3065 6500	930	2.95	3.95	958	3.12	4.18	985	3.28	4.40	1013	3.45	4.63	1040	3.62	4.85	1065	3.80	5.10	1090	3.99	5.35	1115	4.18	5.60			
3305 7000	950	3.32	4.45	978	3.51	4.70	1005	3.69	4.95	1030	3.86	5.18	1055	4.03	5.40	1080	4.24	5.68	1105	4.44	5.95	1130	4.63	6.20			
3400 7200	954	3.44	4.61	984	3.66	4.90	1013	3.87	5.19	1038	4.06	5.44	1063	4.24	5.68	1088	4.43	5.94	1113	4.62	6.19	1136	4.80	6.44			

450 to 625 Pa

LGC180

Air Volume	External Static - Pa (in. w.g.)																							
	475 (1.90)			500 (2.00)			525 (2.10)			550 (2.20)			575 (2.30)			600 (2.40)			625 (2.50)					
	rev/min	kW	BHP	rev/min	BHP	kW	rev/min	kW	BHP	rev/min	kW	BHP	rev/min	kW	BHP	rev/min	kW	BHP	rev/min	kW	BHP	rev/min	kW	BHP
L/s cfm	Field Furnished																							
2265 4800	1087	2.95	3.95	1112	4.13	3.08	1136	3.21	4.30	1159	3.36	4.50	1181	3.51	4.70	1204	3.64	4.88	1226	3.77	5.06			
2360 5000	1095	3.10	4.15	1118	4.33	3.23	1140	3.36	4.50	1163	3.51	4.70	1185	3.66	4.90	1208	3.80	5.10	1230	3.95	5.30			
2595 5500	1110	3.51	4.70	1133	4.90	3.66	1155	3.80	5.10	1178	3.95	5.30	1200	4.10	5.50	1220	4.25	5.70	1240	4.40	5.90			
2830 6000	1120	3.88	5.20	1145	5.43	4.05	1170	4.21	5.65	1193	4.39	5.88	1215	4.55	6.10	1235	4.72	6.33	1255	4.89	6.55			
3065 6500	1140	4.36	5.85	1163	6.08	4.54	1185	4.70	6.30	1205	4.87	6.53	1225	5.04	6.75	1248	5.22	7.00	1270	5.41	7.25			
3305 7000	1155	4.81	6.45	1178	6.70	5.00	1200	5.18	6.95	1220	5.37	7.20	1240	5.56	7.45	1263	5.77	7.73	1285	5.97	8.00			
3400 7200	1159	4.99	6.69	1182	6.96	5.19	1204	5.39	7.23	1226	5.60	7.50	1248	5.80	7.77	1269	5.99	8.03	1289	6.18	8.28			

NOTE - *italics* - field furnished.

AIR RESISTANCE - Factory Installed Options

Air Volume	Gas Heat Exchanger						Economizer	Horizontal Roof Curb		Filters			
	Medium Heat		High Heat							MERV 11		MERV 15	
L/s cfm	Pa	in. wg.	Pa	in. wg.	Pa	in. wg.	Pa	in. wg.	Pa	in. wg.	Pa	in. wg.	
2265 4800	7.4	0.03	12.4	0.05	---	---	19.9	0.08	2.5	0.01	5.0	0.02	
2360 5000	9.9	0.04	14.9	0.06	---	---	19.9	0.08	2.5	0.01	5.0	0.02	
2595 5500	9.9	0.04	17.4	0.07	---	---	24.9	0.10	5.0	0.02	5.0	0.02	
2830 6000	12.4	0.05	19.9	0.08	---	---	27.3	0.11	5.0	0.02	7.4	0.03	
3065 6500	12.4	0.05	22.4	0.09	5.0	0.02	32.3	0.13	5.0	0.02	7.4	0.03	
3305 7000	14.9	0.06	24.9	0.10	9.9	0.04	37.3	0.15	7.4	0.03	7.4	0.03	
3400 7200	17.4	0.07	27.3	0.11	12.4	0.05	39.8	0.16	7.4	0.03	7.4	0.03	

BLOWER DATA

BLOWER TABLE INCLUDES RESISTANCE FOR BASE UNIT WITH STANDARD GAS HEAT, WET INDOOR COIL & AIR FILTERS IN PLACE.

FOR ALL UNITS ADD:

1 - Any factory installed options air resistance (high gas heat, economizer, etc.). See table below

2 - Any field installed accessories air resistance (duct resistance, diffuser, etc.). See page 28

Then determine from table the blower motor output and drive required.

50 to 200 Pa

LGC210

Air Volume		External Static - Pa (in. w.g.)																				
		50 (0.20)			75 (0.30)			100 (0.40)			125 (0.50)			150 (0.60)			175 (0.70)			200 (0.80)		
L/s	cfm	rev/min	kW	BHP	rev/min	kW	BHP	rev/min	kW	BHP	rev/min	kW	BHP	rev/min	kW	BHP	rev/min	kW	BHP	rev/min	kW	BHP
		Low Static - 2.2 kW (3 HP)									Standard Static - 3.7 kW (5 HP)											
2645	5600	609	1.13	1.51	652	1.28	1.71	694	1.42	1.91	732	1.58	2.12	769	1.74	2.33	803	1.89	2.53	837	2.04	2.73
2830	6000	630	1.31	1.75	670	1.45	1.95	710	1.60	2.15	748	1.78	2.38	785	1.94	2.60	818	2.11	2.83	850	2.28	3.05
3065	6500	650	1.53	2.05	690	1.70	2.28	730	1.87	2.50	768	2.05	2.75	805	2.24	3.00	838	2.41	3.23	870	2.57	3.45
3305	7000	675	1.75	2.35	715	1.96	2.63	755	2.16	2.90	790	2.35	3.15	825	2.54	3.40	858	2.75	3.68	890	2.95	3.95
3540	7500	700	2.05	2.75	738	2.26	3.03	775	2.46	3.30	810	2.67	3.58	845	2.87	3.85	878	3.10	4.15	910	3.32	4.45
3775	8000	725	2.39	3.20	763	2.61	3.50	800	2.83	3.80	833	3.04	4.08	865	3.25	4.35	898	3.47	4.65	930	3.69	4.95
3965	8400	746	2.65	3.55	783	2.89	3.87	819	3.12	4.18	853	3.35	4.49	886	3.58	4.80	916	3.82	5.12	946	4.05	5.43

225 to 400 Pa

LGC210

Air Volume		External Static - Pa (in. w.g.)																							
		225 (0.90)			250 (1.00)			275 (1.10)			300 (1.20)			325 (1.30)			350 (1.40)			375 (1.50)			400 (1.60)		
L/s	cfm	rev/min	kW	BHP	rev/min	kW	BHP	rev/min	kW	BHP	rev/min	kW	BHP	rev/min	kW	BHP	rev/min	kW	BHP	rev/min	kW	BHP	rev/min	kW	BHP
		Standard Static - 3.7 kW (5 HP)											Standard Static - 5.6 kW (7.5 HP)												
2645	5600	868	2.19	2.93	899	2.33	3.13	928	2.48	3.33	957	2.63	3.53	985	2.79	3.74	1012	2.95	3.95	1037	3.10	4.15	1062	3.25	4.35
2830	6000	880	2.42	3.25	910	2.57	3.45	940	2.75	3.68	970	2.91	3.90	998	3.08	4.13	1025	3.25	4.35	1050	3.42	4.58	1075	3.58	4.80
3065	6500	900	2.76	3.70	930	2.95	3.95	958	3.12	4.18	985	3.28	4.40	1013	3.45	4.63	1040	3.62	4.85	1065	3.80	5.10	1090	3.99	5.35
3305	7000	920	3.13	4.20	950	3.32	4.45	978	3.51	4.70	1005	3.69	4.95	1030	3.86	5.18	1055	4.03	5.40	1080	4.24	5.68	1105	4.44	5.95
3540	7500	938	3.51	4.70	965	3.69	4.95	993	3.90	5.23	1020	4.10	5.50	1048	4.31	5.78	1075	4.51	6.05	1100	4.72	6.33	1125	4.92	6.60
3775	8000	958	3.90	5.23	985	4.10	5.50	1013	4.33	5.80	1040	4.55	6.10	1065	4.77	6.40	1090	5.00	6.70	1115	5.21	6.98	1140	5.41	7.25
3965	8400	974	4.27	5.73	1001	4.50	6.03	1029	4.74	6.35	1056	4.97	6.66	1081	5.19	6.96	1106	5.42	7.26	1131	5.65	7.58	1156	5.89	7.89

425 to 600 Pa

LGC210

Air Volume		External Static - Pa (in. w.g.)																								
		425 (1.70)			450 (1.80)			475 (1.90)			500 (2.00)			525 (2.10)			550 (2.20)			575 (2.30)			600 (2.40)			
L/s	cfm	rev/min	kW	BHP	rev/min	kW	BHP	rev/min	kW	BHP	rev/min	kW	BHP	rev/min	kW	BHP	rev/min	kW	BHP	rev/min	kW	BHP	rev/min	kW	BHP	
		Field Furnished																								
2645	5600	1087	3.42	4.58	1112	3.58	4.80	1135	3.73	5.00	1157	3.88	5.20	1180	4.04	5.41	1202	4.19	5.62	1223	4.35	5.83	1244	4.51	6.04	
2830	6000	1098	3.73	5.00	1120	3.88	5.20	1145	4.05	5.43	1170	4.21	5.65	1193	4.39	5.88	1215	4.55	6.10	1235	4.72	6.33	1255	4.89	6.55	
3065	6500	1115	4.18	5.60	1140	4.36	5.85	1163	4.54	6.08	1185	4.70	6.30	1205	4.87	6.53	1225	5.04	6.75	1248	5.22	7.00	1270	5.41	7.25	
3305	7000	1130	4.63	6.20	1155	4.81	6.45	1178	5.00	6.70	1200	5.18	6.95	1220	5.37	7.20	1240	5.56	7.45	1263	5.77	7.73	1285	5.97	8.00	
3540	7500	1148	5.13	6.88	1170	5.33	7.15	1193	5.52	7.40	1215	5.71	7.65	1238	5.93	7.95	1260	6.15	8.25	1280	6.34	8.50	1300	6.53	8.75	
3775	8000	1163	5.63	7.55	1185	5.86	7.85	1208	6.06	8.13	1230	6.27	8.40	1253	6.49	8.70	1275	6.71	9.00	1295	6.94	9.30	1315	7.16	9.60	
3965	8400	1179	6.11	8.19	1201	6.33	8.49	1224	6.56	8.79	1246	6.78	9.09	1266	7.00	9.38	1286	7.21	9.67	1307	7.45	9.98	1328	7.68	10.29	

NOTE - *italics* - field furnished.

AIR RESISTANCE - Factory or Field Installed Options

Air Volume		Gas Heat Exchanger				Economizer		Horizontal Roof Curb		Filters			
		Medium. Heat		High Heat						MERV 11		MERV 15	
L/s	cfm	Pa	in. w.g.	Pa	in. w.g.	Pa	in. w.g.	Pa	in. w.g.	Pa	in. w.g.	Pa	in. w.g.
2645	5600	9.9	0.04	17.4	0.07	---	---	24.9	0.10	5.0	0.02	5.0	0.02
2830	6000	12.4	0.05	19.9	0.08	---	---	27.3	0.11	5.0	0.02	7.5	0.03
3065	6500	12.4	0.05	22.4	0.09	5.0	0.02	32.3	0.13	5.0	0.02	7.5	0.03
3305	7000	14.9	0.06	24.9	0.10	9.9	0.04	37.3	0.15	7.5	0.03	7.5	0.03
3540	7500	17.4	0.07	27.3	0.11	14.9	0.06	42.3	0.17	7.5	0.03	7.5	0.03
3775	8000	19.9	0.08	32.3	0.13	22.4	0.09	47.2	0.19	9.9	0.04	7.5	0.03
3965	8400	19.9	0.08	34.8	0.14	27.3	0.11	52.2	0.21	9.9	0.04	7.5	0.03

BLOWER DATA

BLOWER TABLE INCLUDES RESISTANCE FOR BASE UNIT WITH STANDARD GAS HEAT, WET INDOOR COIL & AIR FILTERS IN PLACE.

FOR ALL UNITS ADD:

1 - Any factory installed options air resistance (high gas heat, economizer, etc.). See table below

2 - Any field installed accessories air resistance (duct resistance, diffuser, etc.). See page 28

Then determine from table the blower motor output and drive required.

50 to 200 Pa

LGA/LGC240

Air Volume		External Static - Pa (in. w.g.)																				
		50 (0.20)			75 (0.30)			100 (0.40)			125 (0.50)			150 (0.60)			175 (0.70)			200 (0.80)		
rev/ min	kW	BHP	rev/ min	kW	BHP	rev/ min	kW	BHP	rev/ min	kW	BHP	rev/ min	kW	BHP	rev/ min	kW	BHP	rev/ min	kW	BHP		
L/s	cfm	Low Static - 3.7 kW (5 HP)																		Standard - 5.6 kW		
3020	6400	648	1.48	1.99	688	1.66	2.22	727	1.84	2.46	764	2.01	2.69	801	2.18	2.92	834	2.35	3.15	866	2.53	3.39
3305	7000	675	1.75	2.35	715	1.96	2.63	755	2.16	2.90	790	2.35	3.15	825	2.54	3.40	858	2.75	3.68	890	2.95	3.95
3540	7500	700	2.05	2.75	738	2.26	3.03	775	2.46	3.30	810	2.67	3.58	845	2.87	3.85	878	3.10	4.15	910	3.32	4.45
3775	8000	725	2.39	3.20	763	2.61	3.50	800	2.83	3.80	833	3.04	4.08	865	3.25	4.35	898	3.47	4.65	930	3.69	4.95
4010	8500	750	2.72	3.65	788	2.97	3.98	825	3.21	4.30	858	3.43	4.60	890	3.66	4.90	920	3.90	5.23	950	4.14	5.55
4245	9000	780	3.13	4.20	815	3.38	4.53	850	3.62	4.85	880	3.86	5.18	910	4.10	5.50	940	4.35	5.83	970	4.59	6.15
4530	9600	811	3.63	4.87	845	3.89	5.22	879	4.16	5.57	910	4.43	5.94	941	4.71	6.31	970	4.98	6.67	999	5.24	7.02

NOTE - *italics* - field furnished.

225 to 400 Pa

LGA/LGC240

Air Volume		External Static - Pa (in. w.g.)																							
		225 (0.90)			250 (1.00)			275 (1.10)			300 (1.20)			325 (1.30)			350 (1.40)			375 (1.50)			400 (1.60)		
rev/ min	kW	BHP	rev/ min	kW	BHP	rev/ min	kW	BHP	rev/ min	kW	BHP	rev/ min	kW	BHP	rev/ min	kW	BHP	rev/ min	kW	BHP	rev/ min	kW	BHP		
L/s	cfm	Standard Static - 5.6 kW (7.5 HP)															High Static - 7.5 kW (10 HP)								
3020	6400	896	2.70	3.62	926	2.87	3.85	954	3.04	4.08	981	3.21	4.30	1008	3.38	4.53	1035	3.54	4.75	1060	3.72	4.98	1085	3.89	5.22
3305	7000	920	3.13	4.20	950	3.32	4.45	978	3.51	4.70	1005	3.69	4.95	1030	3.86	5.18	1055	4.03	5.40	1080	4.24	5.68	1105	4.44	5.95
3540	7500	938	3.51	4.70	965	3.69	4.95	993	3.90	5.23	1020	4.10	5.50	1048	4.31	5.78	1075	4.51	6.05	1100	4.72	6.33	1125	4.92	6.60
3775	8000	958	3.90	5.23	985	4.10	5.50	1013	4.33	5.80	1040	4.55	6.10	1065	4.77	6.40	1090	5.00	6.70	1115	5.21	6.98	1140	5.41	7.25
4010	8500	978	4.36	5.85	1005	4.59	6.15	1033	4.83	6.48	1060	5.07	6.80	1085	5.30	7.10	1110	5.52	7.40	1135	5.77	7.73	1160	6.01	8.05
4245	9000	998	4.83	6.48	1025	5.07	6.80	1053	5.33	7.15	1080	5.60	7.50	1105	5.84	7.83	1130	6.08	8.15	1153	6.30	8.45	1175	6.53	8.75
4530	9600	1027	5.51	7.38	1054	5.77	7.74	1079	6.03	8.08	1104	6.27	8.41	1129	6.54	8.77	1154	6.81	9.13	1177	7.06	9.46	1199	7.30	9.78

425 to 600 Pa

LGA/LGC240

Air Volume		External Static - Pa (in. w.g.)																							
		425 (1.70)			450 (1.80)			475 (1.90)			500 (2.00)			525 (2.10)			550 (2.20)			575 (2.30)			600 (2.40)		
rev/ min	kW	BHP	rev/ min	kW	BHP	rev/ min	kW	BHP	rev/ min	kW	BHP	rev/ min	kW	BHP	rev/ min	kW	BHP	rev/ min	kW	BHP	rev/ min	kW	BHP		
L/s	cfm	High Static - 7.5 kW (10 HP)						Field Furnished																	
3020	6400	1110	4.07	5.45	1135	4.24	5.68	1157	4.41	5.91	1180	4.59	6.15	1202	4.77	6.40	1225	4.96	6.65	1246	5.13	6.88	1268	5.30	7.11
3305	7000	1130	4.63	6.20	1155	4.81	6.45	1178	5.00	6.70	1200	5.18	6.95	1220	5.37	7.20	1240	5.56	7.45	1263	5.77	7.73	1285	5.97	8.00
3540	7500	1148	5.13	6.88	1170	5.33	7.15	1193	5.52	7.40	1215	5.71	7.65	1238	5.93	7.95	1260	6.15	8.25	1280	6.34	8.50	1300	6.53	8.75
3775	8000	1163	5.63	7.55	1185	5.86	7.85	1208	6.06	8.13	1230	6.27	8.40	1253	6.49	8.70	1275	6.71	9.00	1295	6.94	9.30	1315	7.16	9.60
4010	8500	1183	6.23	8.35	1205	6.45	8.65	1228	6.68	8.95	1250	6.90	9.25	1270	7.12	9.55	1290	7.35	9.85	1310	7.57	10.15	1330	7.80	10.45
4245	9000	1198	6.77	9.08	1220	7.01	9.40	1243	7.27	9.75	1265	7.53	10.10	1288	7.80	10.45	1310	8.06	10.80	1330	8.28	11.10	1350	8.50	11.40
4530	9600	1222	7.56	10.14	1244	7.83	10.50	1267	8.11	10.87	1289	8.38	11.23	---	---	---	---	---	---	---	---	---	---	---	

AIR RESISTANCE - Factory or Field Installed Options

Air Volume		Gas Heat Exchanger						Economizer		Horizontal Roof Curb		Filters			
		Medium Heat		High Heat		MERV 11						MERV 15			
L/s	cfm	Pa	in. w.g.	Pa	in. w.g.	Pa	in. w.g.	Pa	in. w.g.	Pa	in. w.g.	Pa	in. w.g.	Pa	in. w.g.
3020	6400	12.4	0.05	22.4	0.09	5.0	0.02	32.3	0.13	5.0	0.02	7.5	0.03	7.5	0.03
3305	7000	14.9	0.06	24.9	0.10	9.9	0.04	37.3	0.15	7.5	0.03	7.5	0.03	7.5	0.03
3540	7500	17.4	0.07	27.3	0.11	14.9	0.06	42.3	0.17	7.5	0.03	7.5	0.03	7.5	0.03
3775	8000	19.9	0.08	32.3	0.13	22.4	0.09	47.2	0.19	9.9	0.04	7.5	0.03	7.5	0.03
4010	8500	19.9	0.08	34.8	0.14	27.3	0.11	52.2	0.21	9.9	0.04	7.5	0.03	7.5	0.03
4245	9000	24.9	0.10	39.8	0.16	34.8	0.14	59.7	0.24	9.9	0.04	9.9	0.04	9.9	0.04
4530	9600	27.3	0.11	44.7	0.18	39.8	0.16	64.6	0.26	12.4	0.05	9.9	0.04	9.9	0.04

BLOWER DATA

BLOWER TABLE INCLUDES RESISTANCE FOR BASE UNIT WITH STANDARD GAS HEAT, WET INDOOR COIL & AIR FILTERS IN PLACE.

FOR ALL UNITS ADD:

1 - Any factory installed options air resistance (high gas heat, economizer, etc.). See table below

2 - Any field installed accessories air resistance (duct resistance, diffuser, etc.). See page 28

Then determine from table the blower motor output and drive required.

0 to 150 Pa

LGC300S

Air Volume		External Static - Pa (in. w.g.)																				
		00 (00)			25 (0.10)			50 (0.20)			75 (0.30)			100 (0.40)			125 (0.50)			150 (0.60)		
rev/ min	kW	BHP	rev/ min	kW	BHP	rev/ min	kW	BHP	rev/ min	kW	BHP	rev/ min	kW	BHP	rev/ min	kW	BHP	rev/ min	kW	BHP		
L/s	cfm	Low Static - 3.7 kW (5 HP)									Low Static - 5.6 kW (7.5 HP)											
3775	8000	725	2.39	3.20	763	2.61	3.50	800	2.83	3.80	833	3.04	4.08	865	3.25	4.35	898	3.47	4.65	930	3.69	4.95
4010	8500	750	2.72	3.65	788	2.97	3.98	825	3.21	4.30	858	3.43	4.60	890	3.66	4.90	920	3.90	5.23	950	4.14	5.55
4365	9250	790	3.32	4.45	825	3.58	4.80	860	3.84	5.15	893	4.10	5.50	925	4.36	5.85	955	4.63	6.20	985	4.89	6.55
4720	10000	835	4.03	5.40	868	4.31	5.78	900	4.59	6.15	930	4.85	6.50	960	5.11	6.85	988	5.39	7.23	1015	5.67	7.60
5075	10750	875	4.77	6.40	908	5.10	6.83	940	5.41	7.25	970	5.71	7.65	1000	6.01	8.05	1028	6.30	8.45	1055	6.60	8.85
5225	11500	915	5.52	7.40	948	5.88	7.88	980	6.23	8.35	1010	6.56	8.80	1040	6.90	9.25	1068	7.22	9.68	1095	7.53	10.1

NOTE - *italics* - field furnished.

175 to 350 Pa

LGC300S

Air Volume		External Static - Pa (in. w.g.)																							
		175 (0.70)			200 (0.80)			225 (0.90)			250 (1.00)			275 (1.10)			300 (1.20)			325 (1.30)			350 (1.40)		
rev/ min	kW	BHP	rev/ min	kW	BHP	rev/ min	kW	BHP	rev/ min	kW	BHP	rev/ min	kW	BHP	rev/ min	kW	BHP	rev/ min	kW	BHP	rev/ min	kW	BHP		
L/s	cfm	Low Static - 5.6 kW (7.5 HP)									Standard Static - 7.5 kW (10 HP)									Field Furnished					
3775	8000	958	3.90	5.23	985	4.10	5.50	1013	4.33	5.80	1040	4.55	6.10	1065	4.77	6.40	1090	5.00	6.70	1115	5.21	6.98	1140	5.41	7.25
4010	8500	978	4.36	5.85	1005	4.59	6.15	1033	4.83	6.48	1060	5.07	6.80	1085	5.30	7.10	1110	5.52	7.40	1135	5.77	7.73	1160	6.01	8.05
4365	9250	1013	5.13	6.88	1040	5.37	7.20	1065	5.62	7.53	1090	5.86	7.85	1115	6.12	8.20	1140	6.38	8.55	1163	6.62	8.88	1185	6.86	9.20
4720	10000	1043	5.95	7.98	1070	6.23	8.35	1095	6.49	8.70	1120	6.75	9.05	1145	7.03	9.43	1170	7.31	9.80	1193	7.57	10.15	1215	7.83	10.5
5075	10750	1080	6.90	9.25	1105	7.20	9.65	1130	7.50	10.05	1155	7.80	10.45	1178	8.08	10.83	1200	8.36	11.20	1222	8.63	11.57	---	---	---
5225	11500	1118	7.86	10.53	1140	8.17	10.95	1165	8.50	11.40	1190	8.84	11.85	1210	9.12	12.23	1230	9.40	12.60	---	---	---	---	---	

375 to 550 Pa

LGC300S

Air Volume		External Static - Pa (in. w.g.)																							
		375 (1.50)			400 (1.60)			425 (1.70)			450 (1.80)			475 (1.90)			500 (2.00)			525 (2.25)			550 (2.35)		
rev/ min	kW	BHP	rev/ min	kW	BHP	rev/ min	kW	BHP	rev/ min	kW	BHP	rev/ min	kW	BHP	rev/ min	kW	BHP	rev/ min	kW	BHP	rev/ min	kW	BHP		
L/s	cfm	Field Furnished																							
3775	8000	1163	5.63	7.55	1185	5.86	7.85	1208	6.06	8.13	1230	6.27	8.40	1253	6.49	8.70	1275	6.71	9.00	1295	6.94	9.30	1315	7.16	9.60
4010	8500	1183	6.23	8.35	1205	6.45	8.65	1228	6.68	8.95	1250	6.90	9.25	1270	7.12	9.55	1290	7.35	9.85	1310	7.57	10.15	1330	7.80	10.45
4365	9250	1208	7.11	9.53	1230	7.35	9.85	1253	7.61	10.20	1275	7.87	10.55	1295	8.12	10.88	1315	8.36	11.20	---	---	---	---	---	
4720	10000	1238	8.12	10.88	1260	8.39	11.25	1283	8.67	11.62	---	---	---	---	---	---	---	---	---	---	---	---	---	---	
5075	10750	---	---	---	---	---	---	---	---	---	---	---	---	---	---	---	---	---	---	---	---	---	---	---	
5225	11500	---	---	---	---	---	---	---	---	---	---	---	---	---	---	---	---	---	---	---	---	---	---	---	

AIR RESISTANCE - Factory or Field Installed Options

Air Volume		Gas Heat Exchanger						Economizer		Horizontal Roof Curb		Filters			
		Medium Heat		High Heat		MERV 11						MERV 15			
L/s	cfm	Pa	in. w.g.	Pa	in. w.g.	Pa	in. w.g.	Pa	in. w.g.	Pa	in. w.g.	Pa	in. w.g.	Pa	in. w.g.
3775	8000	19.9	0.08	32.3	0.13	22.4	0.09	32.3	0.13	9.9	0.04	7.5	0.03		
4010	8500	19.9	0.08	34.8	0.14	27.3	0.11	37.3	0.15	9.9	0.04	7.5	0.03		
4365	9250	27.3	0.11	42.3	0.17	37.2	0.15	44.7	0.18	12.4	0.05	7.5	0.03		
4720	10,000	27.3	0.11	47.2	0.19	47.2	0.19	52.2	0.21	14.9	0.06	9.9	0.04		

BLOWER DATA

CEILING DIFFUSER AIR RESISTANCE

Air Volume		Step-Down Diffuser										Flush Diffuser					
		RTD11-185						RTD11-275				FD11-185		FD11-275			
		2 Ends Open		1 Side/2 Ends Open		All Ends & Sides Open		2 Ends Open		1 Side/2 Ends Open		All Ends & Sides Open		Pa	in. w.g.	Pa	in. w.g.
L/s	cfm	Pa	in. w.g.	Pa	in. w.g.	Pa	in. w.g.	Pa	in. w.g.	Pa	in. w.g.	Pa	in. w.g.	Pa	in. w.g.		
2360	5000	127	.51	109	.44	97	.39	---	---	---	---	---	---	67	.27	---	---
2455	5200	139	.56	119	.48	104	.42	---	---	---	---	---	---	75	.30	---	---
2550	5400	152	.61	129	.52	112	.45	---	---	---	---	---	---	82	.33	---	---
2645	5600	164	.66	139	.56	119	.48	---	---	---	---	---	---	90	.36	---	---
2735	5800	177	.71	147	.59	127	.51	---	---	---	---	---	---	97	.39	---	---
2830	6000	189	.76	157	.63	137	.55	90	.36	77	.31	67	.27	104	.42	72	.29
2925	6200	199	.80	169	.68	147	.59	---	---	---	---	---	---	114	.46	---	---
3020	6400	214	.86	179	.72	157	.63	---	---	---	---	---	---	124	.50	---	---
3065	6500	---	---	---	---	---	---	104	.42	90	.36	77	.31	---	---	85	.34
3115	6600	229	.92	191	.77	167	.67	---	---	---	---	---	---	134	.54	---	---
3210	6800	246	.99	206	.83	174	.72	---	---	---	---	---	---	144	.58	---	---
3305	7000	256	1.03	216	.87	189	.76	122	.49	102	.41	90	.36	154	.62	99	.40
3400	7200	271	1.09	229	.92	199	.80	---	---	---	---	---	---	164	.66	---	---
3490	7400	286	1.15	241	.97	209	.84	---	---	---	---	---	---	174	.70	---	---
3540	7500	---	---	---	---	---	---	127	.51	114	.46	102	.41	---	---	112	.45
3585	7600	301	1.20	254	1.02	219	.88	---	---	---	---	---	---	184	.74	---	---
3775	8000	---	---	---	---	---	---	147	.59	122	.49	107	.43	---	---	124	.50
4010	8500	---	---	---	---	---	---	172	.69	144	.58	124	.50	---	---	142	.57
4245	9000	---	---	---	---	---	---	196	.79	167	.67	144	.58	---	---	164	.66
4485	9500	---	---	---	---	---	---	221	.89	186	.75	162	.65	---	---	184	.74
4720	10,000	---	---	---	---	---	---	249	1.00	209	.84	182	.73	---	---	201	.81
4955	10,500	---	---	---	---	---	---	273	1.10	229	.92	199	.80	---	---	221	.89
5190	11,000	---	---	---	---	---	---	301	1.21	251	1.01	219	.88	---	---	239	.96

BLOWER DATA

POWER EXHAUST FANS STANDARD STATIC OPERATION

Pa	Return Duct Negative Static Pressure		Air Volume	
	in. w.g.		L/s	cfm
0	0		3395	7190
12	0.05		3230	6840
25	0.10		3040	6440
37	0.15		2795	5925
50	0.20		2545	5390
62	0.25		2275	4825
75	0.30		1990	4215
87	0.35		1690	3585
100	0.40		1380	2925
112	0.45		1055	2240
125	0.50		725	1535

CEILING DIFFUSER AIR THROW DATA

Model No.	Air Volume		¹ Effective Throw Range			
	L/s	cfm	Step-Down		Flush	
			m	ft.	m	ft.
156H 180	Diffuser Model	Diffuser Model	RTD11-185	RTD11-185	FD11-185	FD11-185
	2645	5600	12 - 15	39 - 49	9 - 11	28 - 37
	2740	5800	13 - 16	42 - 51	9 - 12	29 - 38
	2830	6000	13 - 17	44 - 54	12 - 15	40 - 50
	2925	6200	14 - 17	45 - 55	13 - 16	42 - 51
	3020	6400	14 - 17	46 - 55	13 - 16	53 - 52
	3115	6600	14 - 17	57 - 56	14 - 17	45 - 56
210 240 300S	Diffuser Model	Diffuser Model	RTD11-275	RTD11-275	FD11-275	FD11-275
	3400	7200	10 - 12	33 - 38	8 - 11	26 - 35
	3490	7400	11 - 12	35 - 40	9 - 11	28 - 37
	3585	7600	11 - 13	36 - 41	9 - 12	29 - 38
	3680	7800	11 - 13	38 - 43	12 - 15	40 - 50
	3775	8000	12 - 13	39 - 44	13 - 16	42 - 51
	3870	8200	12 - 14	41 - 46	13 - 16	43 - 52
	3965	8400	13 - 15	43 - 49	13 - 17	44 - 54
	4060	8600	13 - 15	44 - 50	14 - 17	46 - 57
4155	8800	14 - 17	47 - 55	15 - 18	48 - 59	

¹ Throw is the horizontal or vertical distance an airstream travels on leaving the outlet or diffuser before the maximum velocity is reduced to 15 m (50 ft.) per minute. Four sides open.

ELECTRICAL DATA

		LGC156H2			LGC156H4					
Voltage - 50hz - 3 phase with neutral		380/420V			380/420V					
Compressors (3)	Rated Load Amps (total)	7.1 (21.3)			7.9 (23.7)					
	Locked Rotor Amps (total)	50 (150)			46 (138)					
Outdoor Fan Motors (4)	Full Load Amps (total)	1.3 (5.2)			1.3 (5.2)					
	Locked Rotor Amps (total)	2.4 (9.6)			2.4 (9.6)					
Standard Power Exhaust Fans (2)	Watts (Horsepower)	249 (1/3)			249 (1/3)					
	Full Load Amps(total)	1.3 (2.6)			1.3 (2.6)					
	Locked Rotor Amps (total)	2.4 (4.8)			2.4 (4.8)					
Indoor Blower Motor	kW (Horsepower)	1.5 (2)	2.2 (3)	3.7 (5)	1.5 (2)	2.2 (3)	3.7 (5)			
	Rated Load Amps	3.5	5.0	7.8	3.5	5.0	7.8			
	Locked Rotor Amps	22.1	27	41	22.1	27	41			
¹ Maximum Overcurrent Protection	Unit only	35	40	40	40	40	45			
	with power exhaust	40	40	45	40	45	45			
² Minimum Circuit Ampacity	Unit only	32	34	37	35	36	39			
	with power exhaust	35	36	39	37	39	42			
Disconnect	84M13			84M13						
		LGC180S2			LGC180H2			LGC180H4		
Voltage - 50hz - 3 phase with neutral		380/420V			380/420V			380/420V		
Compressors (3)	Rated Load Amps (total)	7.4 (22.2)			9 (27)			7.8 (23.4)		
	Locked Rotor Amps (total)	59.6 (178.8)			62 (186)			52 (156)		
Outdoor Fan Motors (4)	Full Load Amps (total)	1.3 (5.2)			1.3 (5.2)			1.3 (5.2)		
	Locked Rotor Amps (total)	2.4 (9.6)			2.4 (9.6)			2.4 (9.6)		
Standard Power Exhaust Fans (2)	Watts (Horsepower)	249 (1/3)			249 (1/3)			249 (1/3)		
	Full Load Amps(total)	1.3 (2.6)			1.3 (2.6)			1.3 (2.6)		
	Locked Rotor Amps (total)	2.4 (4.8)			2.4 (4.8)			2.4 (4.8)		
Indoor Blower Motor	kW (Horsepower)	2.2 (3)	3.7 (5)	5.6 (7.5)	2.2 (3)	3.7 (5)	5.6 (7.5)	2.2 (3)	3.7 (5)	5.6 (7.5)
	Rated Load Amps	5	7.8	11.1	5	7.8	11.1	5	7.8	11.1
	Locked Rotor Amps	27	41	66	27	41	66	27	41	66
¹ Maximum Overcurrent Protection	Unit only	40	45	50	45	50	50	40	45	50
	with power exhaust	40	45	50	50	50	50	45	45	50
² Minimum Circuit Ampacity	Unit only	35	38	41	40	43	46	36	39	42
	with power exhaust	37	40	43	43	45	49	38	41	45
Disconnect	84M13			84M13			84M13			
		LGC210S2			LGC210H2			LGC210H4		
Voltage - 50hz - 3 phase with neutral		380/420V			380/420V			380/420V		
Compressors (4)	Rated Load Amps (total)	7.1 (28.4)			7.1 (28.4)			7.9 (31.6)		
	Locked Rotor Amps (total)	50 (200)			50 (200)			46 (184)		
Outdoor Fan Motors (4)	Full Load Amps (total)	1.3 (5.2)			1.3 (5.2)			1.3 (5.2)		
	Locked Rotor Amps (total)	2.4 (9.6)			2.4 (9.6)			2.4 (9.6)		
Standard Power Exhaust Fans (2)	Watts (Horsepower)	249 (1/3)			249 (1/3)			249 (1/3)		
	Full Load Amps(total)	1.3 (2.6)			1.3 (2.6)			1.3 (2.6)		
	Locked Rotor Amps (total)	2.4 (4.8)			2.4 (4.8)			2.4 (4.8)		
Indoor Blower Motor	kW (Horsepower)	2.2 (3)	3.7 (5)	5.6 (7.5)	2.2 (3)	3.7 (5)	5.6 (7.5)	2.2 (3)	3.7 (5)	5.6 (7.5)
	Rated Load Amps	5	7.8	11	5	7.8	11.1	5	7.8	11.1
	Locked Rotor Amps	27	41	66	27	41	66	27	41	66
¹ Maximum Overcurrent Protection	Unit only	45	50	50	45	50	50	50	50	60
	with power exhaust	50	50	60	50	50	60	50	50	60
² Minimum Circuit Ampacity	Unit only	41	44	47	41	44	47	44	47	50
	with power exhaust	43	46	50	43	46	50	47	50	53
Disconnect	84M13			84M13			84M13			

NOTE - Extremes of operating range are plus and minus 10% of line voltage.

¹ HACR type breaker or fuse.

² Refer to local electrical codes to determine wire, fuse and disconnect size requirements.

ELECTRICAL DATA

		LGC240S2			LGA240H2			LGA240H4		
Voltage - 50hz - 3 phase with neutral		380/420V			380/420V			380/420V		
Compressors (4)	Rated Load Amps (total)	7.4 (29.6)			9 (36)			7.8 (31.2)		
	Locked Rotor Amps (total)	59.6 (238.4)			62 (248)			52 (208)		
Outdoor Fan Motors (4)	Full Load Amps (total)	1.3 (5.2)			1.3 (5.2)			1.3 (5.2)		
	Locked Rotor Amps (total)	2.4 (9.6)			2.4 (9.6)			2.4 (9.6)		
Standard Power Exhaust Fans (2)	Watts (Horsepower)	249 (1/3)			249 (1/3)			249 (1/3)		
	Full Load Amps (total)	1.3 (2.6)			1.3 (2.6)			1.3 (2.6)		
	Locked Rotor Amps (total)	2.4 (4.8)			2.4 (4.8)			2.4 (4.8)		
Indoor Blower Motor	kW (Horsepower)	3.7 (5)	5.6 (7.5)	7.5 (10)	3.7 (5)	5.6 (7.5)	7.5 (10)	3.7 (5)	5.6 (7.5)	7.5 (10)
	Rated Load Amps	7.8	11.1	15.2	7.8	11.1	15.2	7.8	11.1	15.2
	Locked Rotor Amps	41	66	84	41	66	84	41	66	84
² Maximum Overcurrent Protection	Unit only	50	50	60	60	60	70	50	60	70
	with power exhaust	50	60	70	60	60	70	50	60	70
¹ Minimum Circuit Ampacity	Unit only	45	48	52	52	55	59	47	50	54
	with power exhaust	48	51	55	54	58	62	49	53	57
Disconnect		84M13			84M13			84M13		
		LGC300S2				LGC300S4				
Voltage - 50hz - 3 phase with neutral		380/420V				380/420V				
Compressors (4)	Rated Load Amps (total)	9 (36)				10.6 (42.4)				
	Locked Rotor Amps (total)	75 (300)				75 (300)				
Outdoor Fan Motors (4)	Full Load Amps (total)	1.5 (6)				1.5 (6)				
	Locked Rotor Amps (total)	3 (12)				3 (12)				
Standard Power Exhaust Fans (2)	Watts (Horsepower)	249 (1/3)				249 (1/3)				
	Full Load Amps (total)	1.3 (2.6)				1.3 (2.6)				
	Locked Rotor Amps (total)	2.4 (4.8)				2.4 (4.8)				
Indoor Blower Motor	kW (Horsepower)	3.7 (5)	5.6 (7.5)	7.5 (10)	3.7 (5)	5.6 (7.5)	7.5 (10)	3.7 (5)	5.6 (7.5)	7.5 (10)
	Rated Load Amps	7.8	11	15.2	7.8	11.1	15.2	7.8	11.1	15.2
	Locked Rotor Amps	41	66	84	41	66	84	41	66	84
¹ Maximum Overcurrent Protection	Unit only	60	60	70	60	60	70	60	60	70
	with power exhaust	60	60	70	60	60	70	60	60	70
² Minimum Circuit Ampacity	Unit only	53	56	60	59	63	67	63	67	67
	with power exhaust	55	58	63	62	65	69	65	69	69
Disconnect		84M13				84M13				

NOTE - Extremes of operating range are plus and minus 10% of line voltage.

¹ HACR type breaker or fuse.

² Refer to local electrical codes to determine wire, fuse and disconnect size requirements.

OUTDOOR SOUND DATA

Unit Model No.	Octave Band Sound Power Levels dBA, re 10 ⁻¹² Watts							¹ Sound Rating Number (dB)
	Center Frequency - HZ							
	125	250	500	1000	2000	4000	8000	
156H, 180S, 180H	80	83	87	88	84	80	71	93
210S, 210H, 240S, 240H	77	83	87	87	84	80	71	92
300S	80	84	87	87	83	77	64	93

NOTE - The octave sound power data shown does not include tonal correction.

¹ Tested according to ARI Standard 270-95 test conditions and ANSI Standard S1.32-1981.

UNIT CLEARANCES - MM (INCHES)

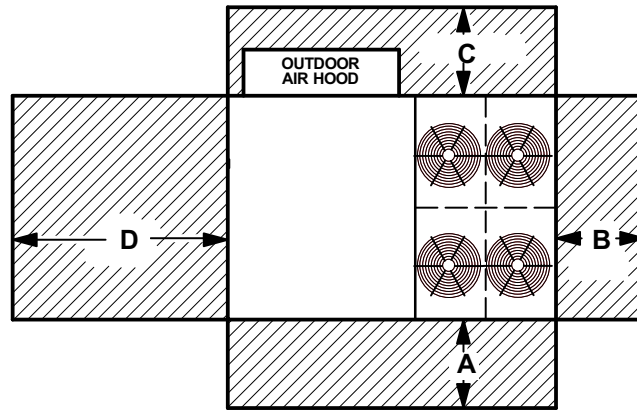

¹ Unit Clearance	A		B		C		D		Top Clearance
	mm	in.	mm	in.	mm	in.	mm	in.	
Service Clearance	1524	60	914	36	914	36	1676	66	Unobstructed
Clearance to Combustibles	914	36	25	1	25	1	25	1	
Minimum Operation Clearance	1143	45	914	36	914	36	1041	41	

NOTE - Entire perimeter of unit base requires support when elevated above the mounting surface.

¹ **Service Clearance** - Required for removal of serviceable parts.

Clearance to Combustibles - Required clearance to combustible material.

Minimum Operation Clearance - Required clearance for proper unit operation.

OPTIONAL CONVENTIONAL TEMPERATURE CONTROL SYSTEMS - FIELD INSTALLED

COMMERCIAL TOUCHSCREEN THERMOSTAT



Intuitive Touchscreen Interface - **Two Stage Heating / Two Stage Cooling Conventional or Heat Pump** - Seven Day Programmable - Four Time Periods/Day - Economizer Output - Title 24 Compliant - ENERGY STAR® Qualified - Backlit Display - Automatic Changeover

C0STAT02AE1L

Sensors For Touchscreen Thermostat

1 Remote non-adjustable wall mount 20k temperature sensor	C0SNZN01AE1-
1 Remote non-adjustable wall mount 10k averaging temperature sensor	C0SNZN73AE1-
1 Remote non-adjustable duct mount temperature sensor	C0SNDC00AE1-
Outdoor temperature sensor	C0SNSR03AE1-

Accessories For Touchscreen Thermostat

Locking cover (clear)	C0MISC15AE1-
---------------------------------	--------------

¹ Remote sensors for C0STAT02AE1L can be applied in the following combinations: (1) C0SNZN01AE1-, (2) C0SNZN73AE1-, (2) C0SNZN01AE1- and (1) C0SNZN73AE1-, (4) C0SNZN01AE1-, (3) C0SNZN01AE1- and (2) C0SNZN73AE1.

DIGITAL NON-PROGRAMMABLE THERMOSTATS



Intuitive Interface - Automatic Changeover - Simple Up and Down Temperature Control

Two-stage heating / cooling conventional systems	C0STAT10AE1L
---	--------------

Sensor For Digital Non-Programmable Thermostats Above

Remote wall mounted temperature sensor	C0SNZN00AE1-
--	--------------



Intuitive Interface - Automatic Changeover - Backlit Display - Simple Up and Down Temperature Control

One-stage heating / cooling conventional systems	C0STAT12AE1L
---	--------------

Sensor For Digital Non-Programmable Thermostats Above

Outdoor temperature sensor	C0SNSR04AE1-
--------------------------------------	--------------

Accessories For Digital Non-Programmable Thermostats Above

Optional wall mounting plate	C0MISC17AE1-
--	--------------

WEIGHT DATA

Model Number	Net		Shipping	
	kg	lbs.	kg	lbs.
156H/180 Base Unit	1070	2355	1159	2555
156H/180 Max. Unit	1179	2600	1252	2760
210 Base Unit	1127	2485	1218	2685
210 Max. Unit	1216	2680	1306	2880
240/300S Base Unit	1150	2535	1241	2735
240/300S Max. Unit	1243	2740	1334	2940

OPTIONS / ACCESSORIES

		Weight	
		kg	lbs.
CEILING DIFFUSERS			
Step-Down	RTD11-185	178	392
	RTD11-275	183	403
Flush	FD11-185	135	289
	FD11-275	165	363
Transitions	LASRT18	36	80
	LASRT21/24	34	75

ECONOMIZER / OUTDOOR AIR / EXHAUST

Economizer	LAREMD18/24	39	86
Barometric Relief			
Down-Flow Barometric Relief Dampers	LAGED18/24	14	30
Horizontal Barometric Relief Dampers	LAGEDH18/24	9	20
Outdoor Air Dampers			
Damper Section (down-flow) - Automatic	LAOADM18/24	24	52
Damper Section (down-flow) - Manual	LAOAD18/24	22	49
Outdoor Air Hood (down-flow)	C1HOOD10C	29	65
Power Exhaust	C1PWRE20C	28	62

HEAT EXCHANGER

High Fire Heat Exchanger		36	80
--------------------------	--	----	----

PACKAGING

LTL Packaging (less than truck load)		127	280
--------------------------------------	--	-----	-----

ROOF CURBS - STANDARD

Down-Flow			
356 mm (14 in.) height	LARMF18/36-14	73	160
610 mm (24 in.) height	LARMF18/36-24	100	220
Horizontal			
660 mm (26 in.) height	LARMFH18/24-26	191	420
940 mm (37 in.) height	LARMFH18/24-37	263	580
762 mm (30 in.) height	LARMFH30/36-30	202	445
1041 mm (41 in.) height	LARMFH30/36-41	329	725

ROOF CURBS - CLIPLOCK 1000

Down-Flow			
356 mm (14 in.) height	LARMF18/30S-14	75	165
457 mm (18 in.) height	LARMF18/30S-18	88	193
610 mm (24 in.) height	LARMF18/30S-24	106	234
Horizontal			
660 mm (26 in.) height	LARMFH18/24S-26	207	457
940 mm (37 in.) height	LARMFH18/24S-37	223	491
762 mm (30 in.) height	LARMFH30/36S-30	207	456
1041 mm (41 in.) height	LARMFH30/36S-41	218	480

Base Unit - The unit with low fire heat exchanger NO OPTIONS.

Max. Unit - The unit with ALL OPTIONS Installed. (High Input Heat Exchanger, Economizer, Power Exhaust Fans, Controls)

DIMENSIONS - MM (INCHES)

Model Number	CORNER WEIGHTS								CENTER OF GRAVITY			
	AA		BB		CC		DD		EE		FF	
	kg	lbs.	kg	lbs.	kg	lbs.	kg	lbs.	mm	inch	mm	inch
156H/180 Base Unit	244	539	212	467	284	626	328	723	1270	50	978	38-1/2
156H/180 Max. Unit	271	597	272	600	319	703	318	700	1372	54	1054	41-1/2
210 Base Unit	237	523	225	497	324	714	341	751	1334	52-1/2	940	37
210 Max. Unit	283	625	269	594	323	712	340	749	1334	52-1/2	1041	41
240/300S Base Unit	236	521	242	534	340	749	332	732	1384	54-1/2	953	37-1/2
240/300S Max. Unit	284	626	275	606	337	742	348	767	1346	53	1029	40-1/2

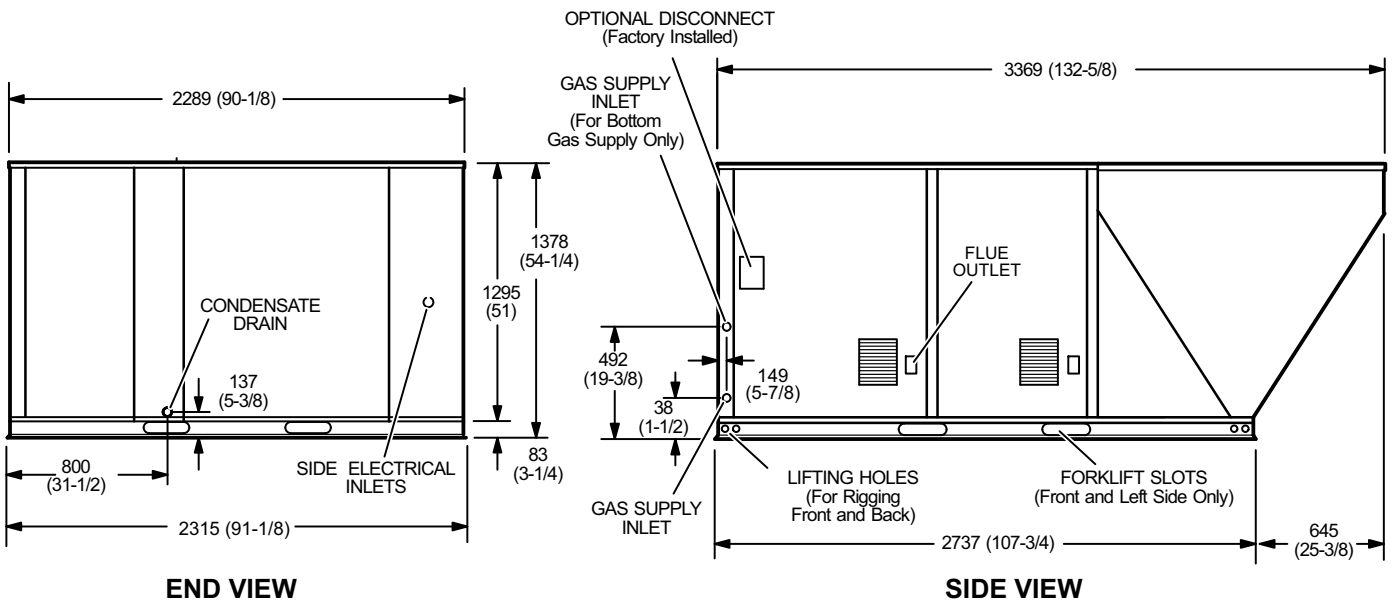
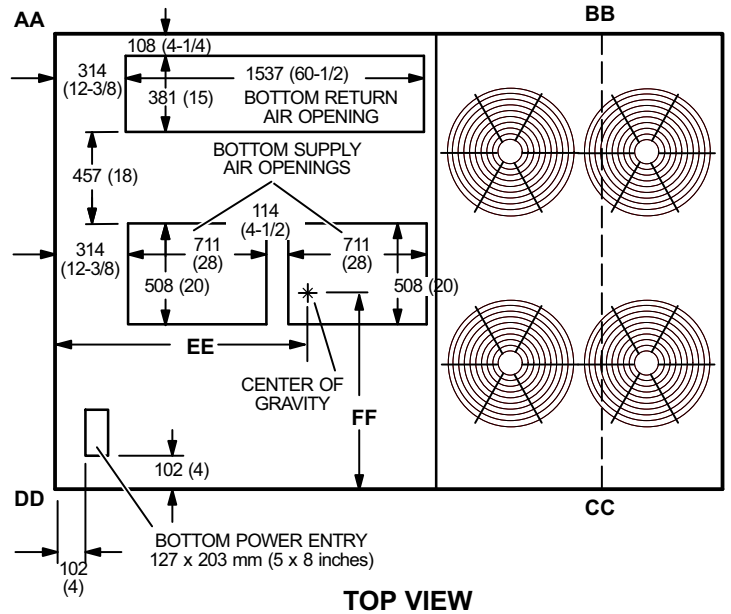

ACCESSORY DIMENSIONS - MM (INCHES)

**OPTIONAL OUTDOOR AIR HOOD DETAIL
WITH STANDARD STATIC POWER EXHAUST FANS**

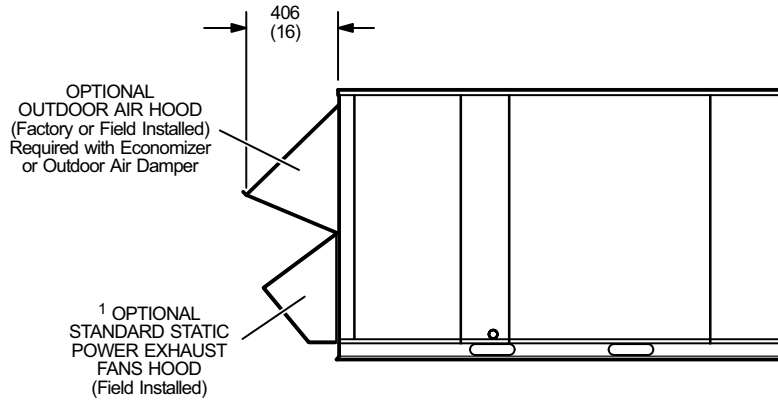

¹ Field Installed in Return Air Duct for Horizontal Applications.

HORIZONTAL BAROMETRIC RELIEF DAMPERS

(Field installed in horizontal return air duct adjacent to unit)

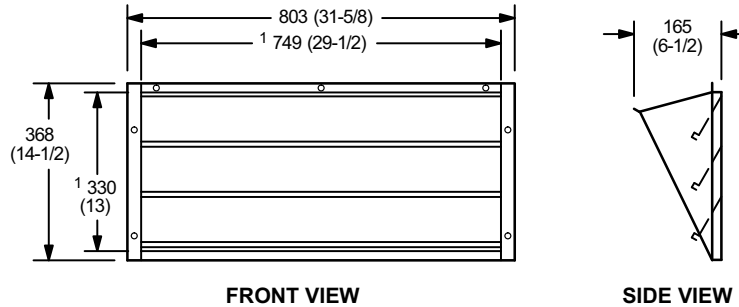

NOTE - Two furnished per order no.

¹ NOTE - Opening size required in return air duct.

ACCESSORY DIMENSIONS - MM (INCHES)

STANDARD ROOF CURBS - DOUBLE DUCT OPENING

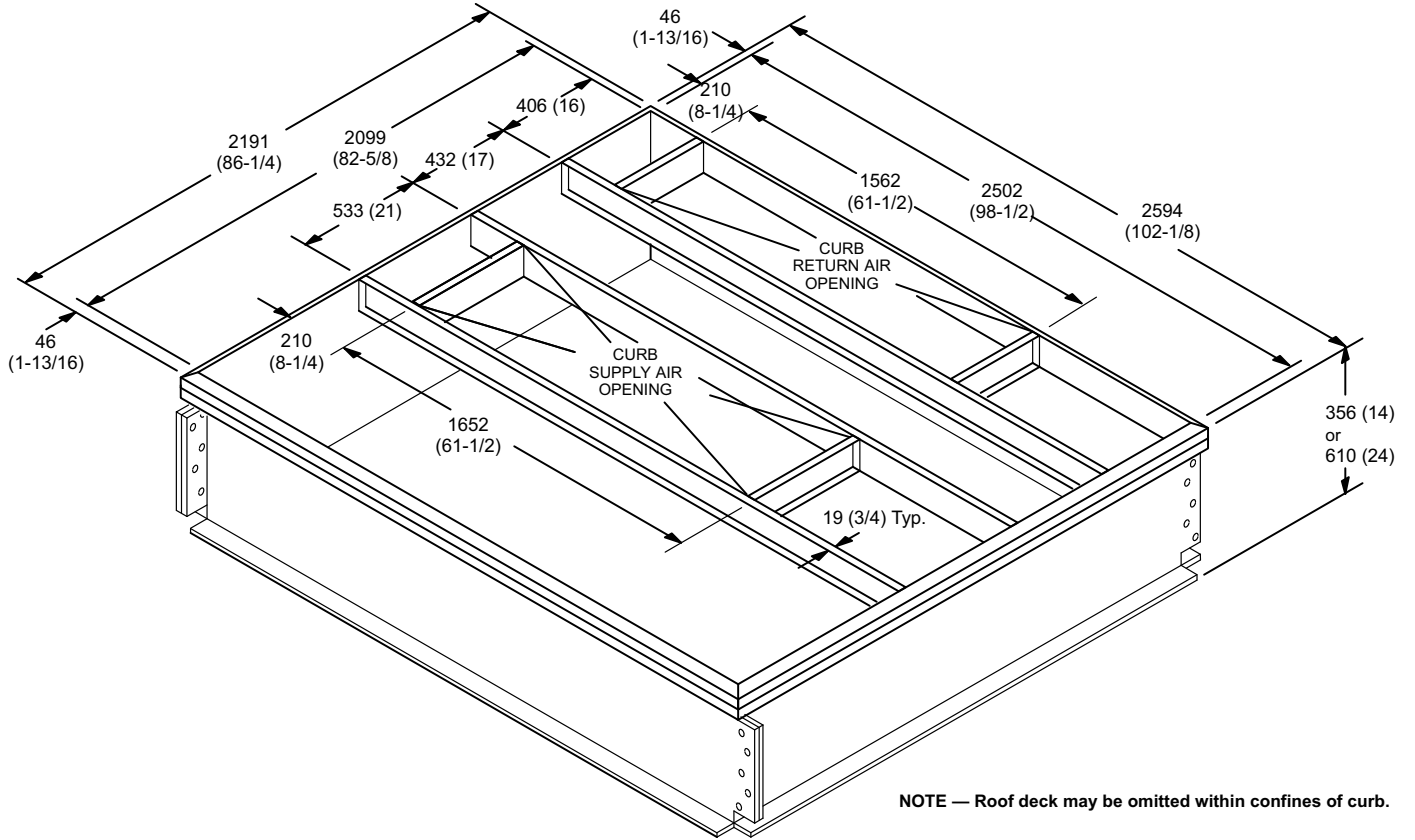

TYPICAL FLASHING DETAIL FOR ROOF CURB

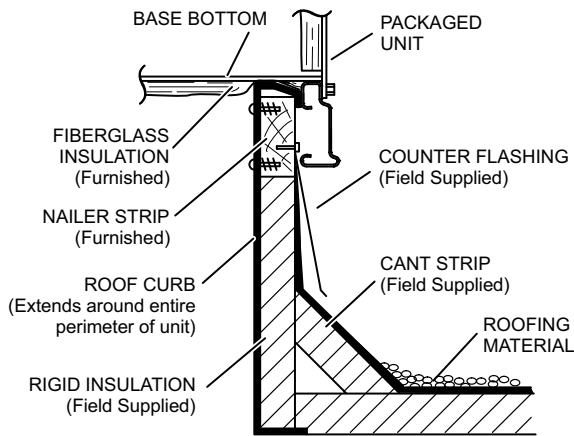

DETAIL ROOF CURB

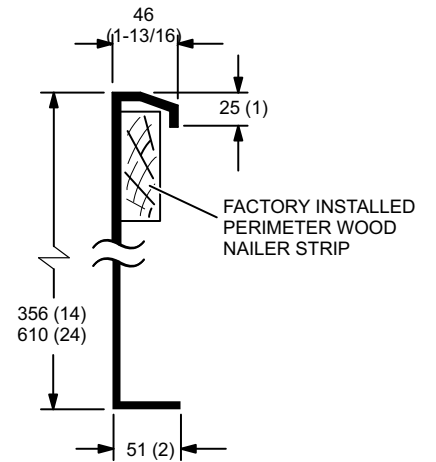

ACCESSORY DIMENSIONS - MM (INCHES)

CLIPLOCK 1000 ROOF CURBS - DOUBLE DUCT OPENING

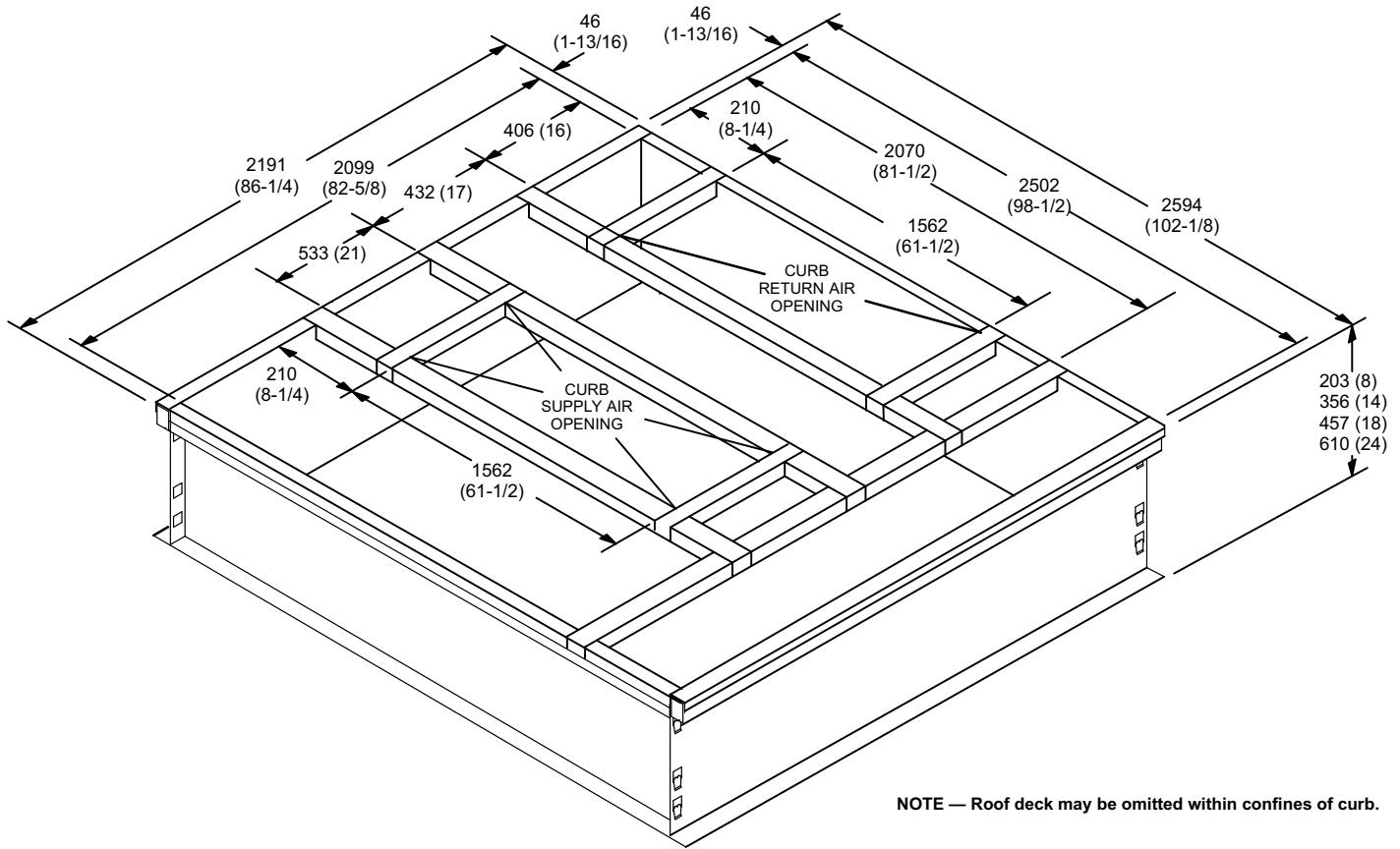

NOTE — Roof deck may be omitted within confines of curb.

TYPICAL FLASHING DETAIL FOR ROOF CURB

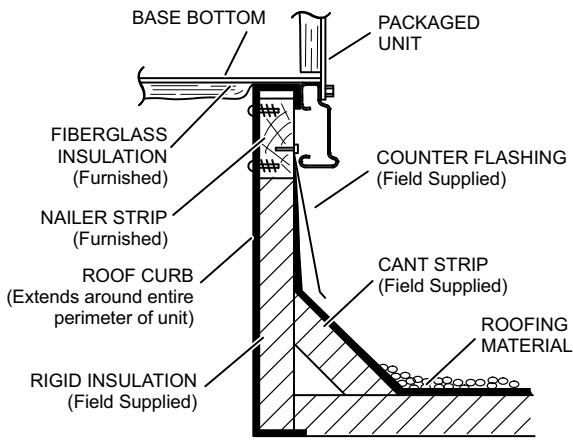

DETAIL ROOF CURB

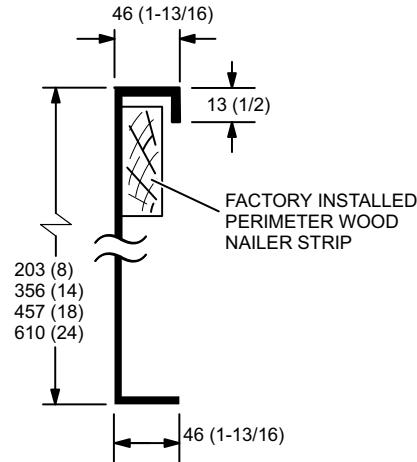

ACCESSORY DIMENSIONS - MM (INCHES)

STANDARD ROOF CURBS WITH SUPPLY & RETURN AIR TRANSITIONS FOR CEILING DIFFUSERS

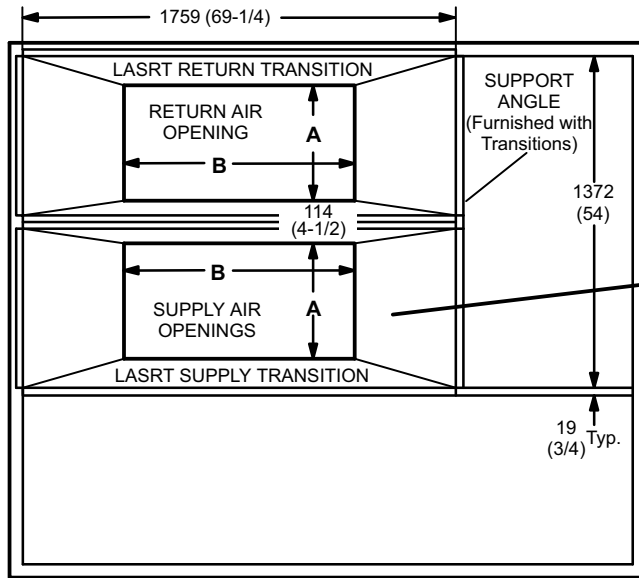

TOP VIEW

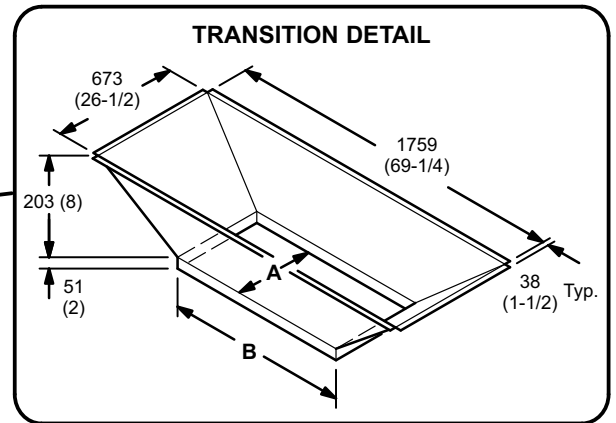

TRANSITION OPENING SIZES

Model Number	A		B	
	mm	inch	mm	inch
LASRT18	457	18	914	36
LASRT21/24	610	24	1219	48

ACCESSORY DIMENSIONS - MM (INCHES)

HORIZONTAL ROOF CURBS - Requires Optional Horizontal Return Air Panel Kit

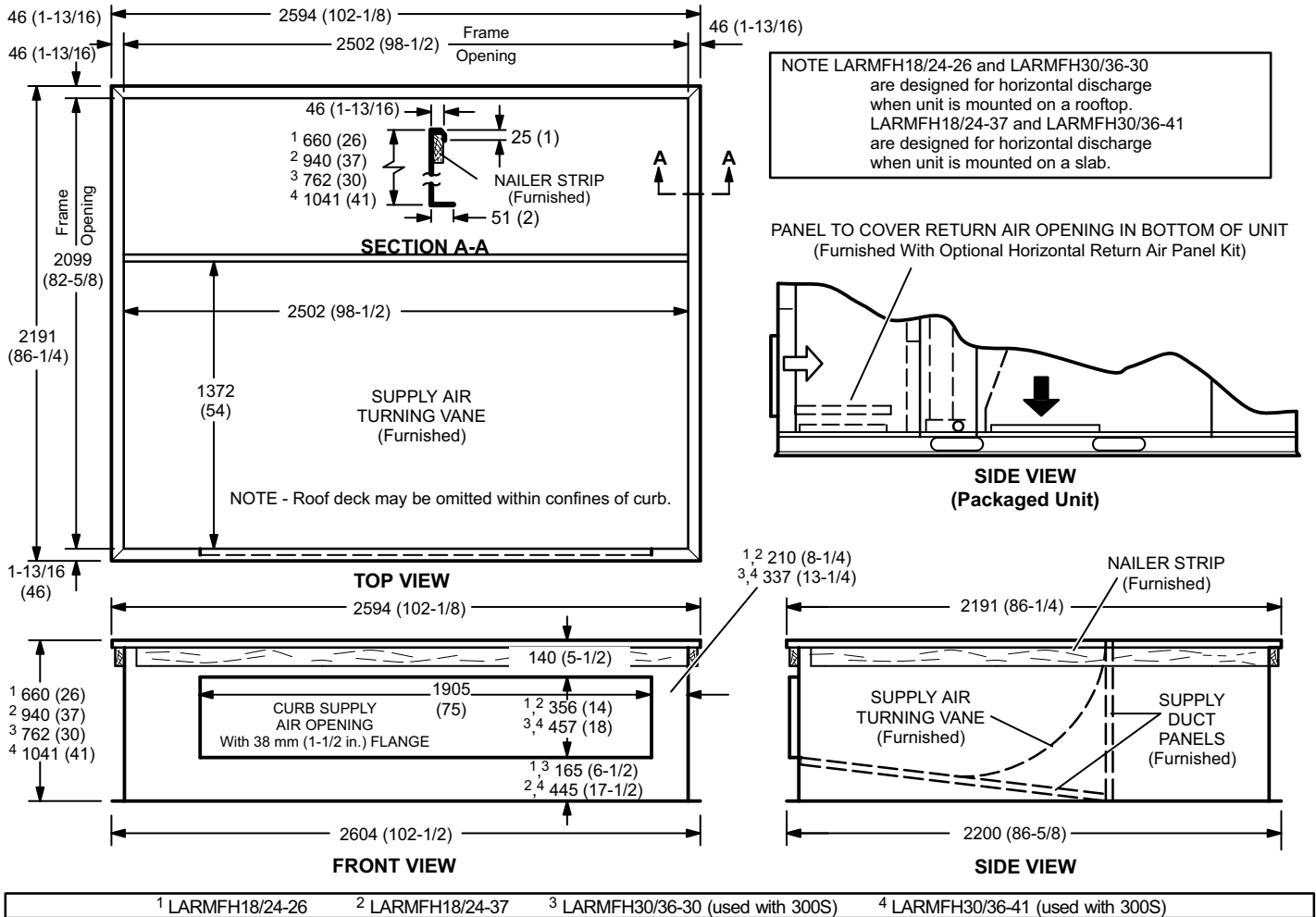

HORIZONTAL SUPPLY AND RETURN AIR OPENINGS WITH HORIZONTAL ROOF CURB

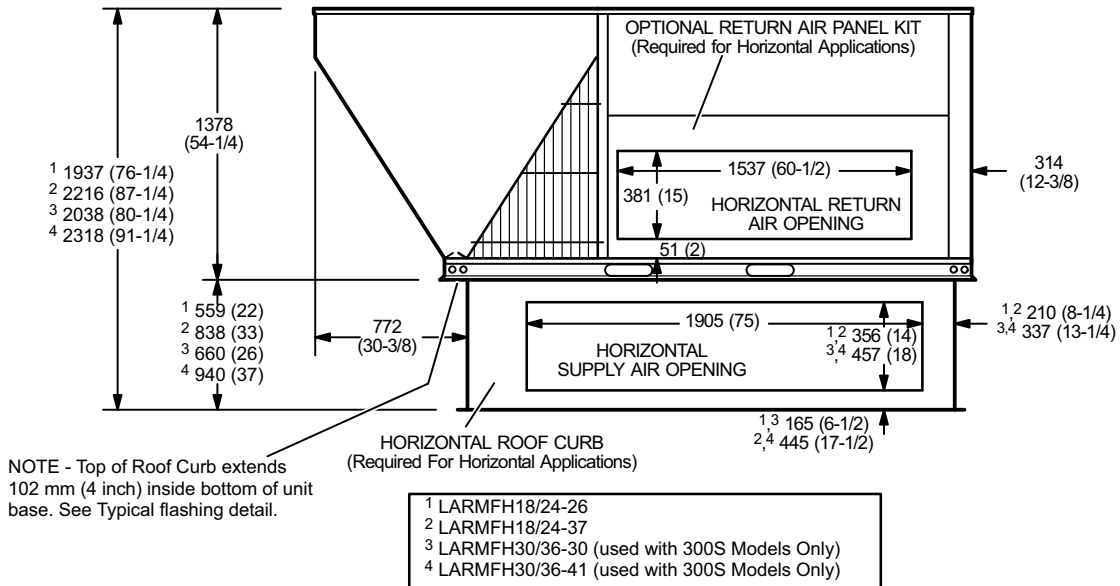

ACCESSORY DIMENSIONS - MM (INCHES)

COMBINATION CEILING SUPPLY AND RETURN DIFFUSERS

STEP-DOWN CEILING DIFFUSER

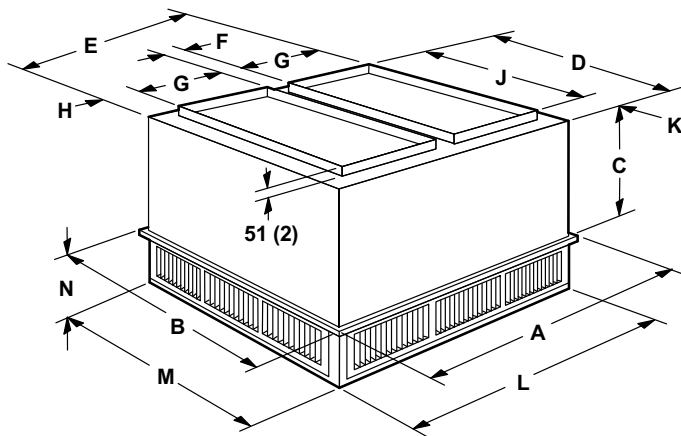

Model Number		RTD11-185	RTD11-275
A	mm	1210	1514
	in.	47-5/8	59-5/8
B	mm	1210	1514
	in.	47-5/8	59-5/8
C	mm	625	778
	in.	24-5/8	30-5/8
D	mm	1156	1461
	in.	45-1/2	57-1/2
E	mm	1156	1461
	in.	45-1/2	57-1/2
F	mm	114	114
	in.	4-1/2	4-1/2
G	mm	457	610
	in.	18	24
H	mm	64	64
	in.	2-1/2	2-1/2
J	mm	914	1219
	in.	36	48
K	mm	121	121
	in.	4-3/4	4-3/4
L	mm	1156	1461
	in.	45-1/2	57-1/2
M	mm	1156	1461
	in.	45-1/2	57-1/2
N	mm	257	283
	in.	10-1/8	11-1/8
Duct Size	mm	457 x 914	610 x 1219
	in.	18 x 36	24 x 48

FLUSH CEILING DIFFUSER

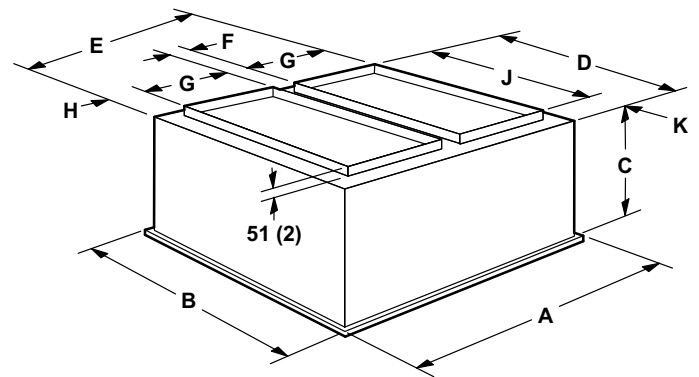

Model Number		FD11-185	FD11-275
A	mm	1210	1514
	in.	47-5/8	59-5/8
B	mm	1210	1514
	in.	47-5/8	59-5/8
C	mm	743	895
	in.	29-1/4	35-1/4
D	mm	1143	1148
	in.	45	57
E	mm	1143	1448
	in.	45	57
F	mm	114	114
	in.	4-1/2	4-1/2
G	mm	457	610
	in.	18	24
H	mm	57	57
	in.	2-1/4	2-1/4
J	mm	914	1219
	in.	36	48
K	mm	114	114
	in.	4-1/2	4-1/2
Duct Size	mm	457 x 914	610 x 1219
	in.	18 x 36	24 x 48



Visit us at www.lennox.com
For the latest technical information, www.lennoxcommercial.com
Contact us at 1-800-4-LENNOX

