

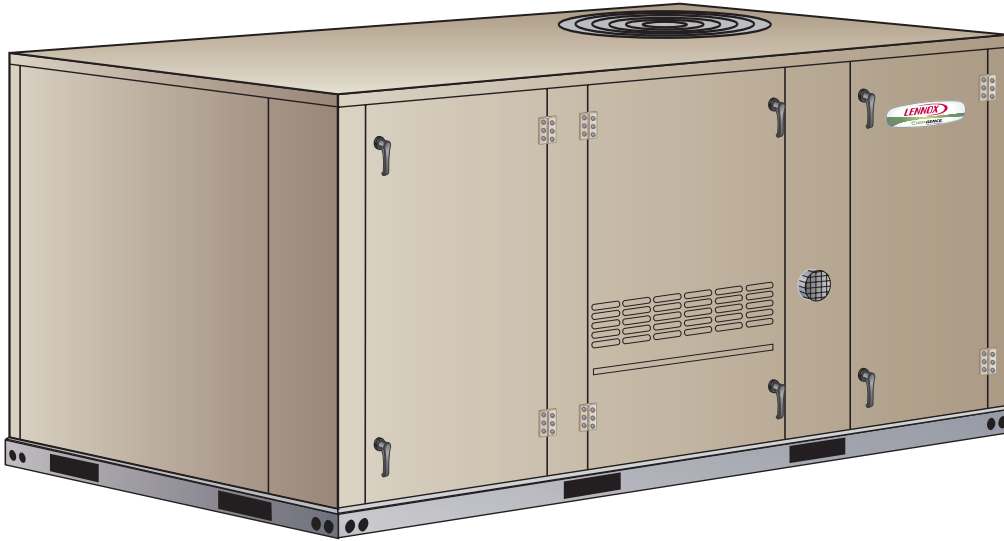

**COMMERCIAL
PRODUCT SPECIFICATIONS**

Bulletin No. 490138
March 2021
Supersedes November 2019



10.5 to 21 kW (3 to 6 Ton)
Net Cooling Capacity - 9.2 to 19.2 kW (32 400 to 65 500 Btuh)
Gas Input Heat Capacity - 16.7 to 38.7 kW (57 000 to 132 000 Btuh)

MODEL NUMBER IDENTIFICATION

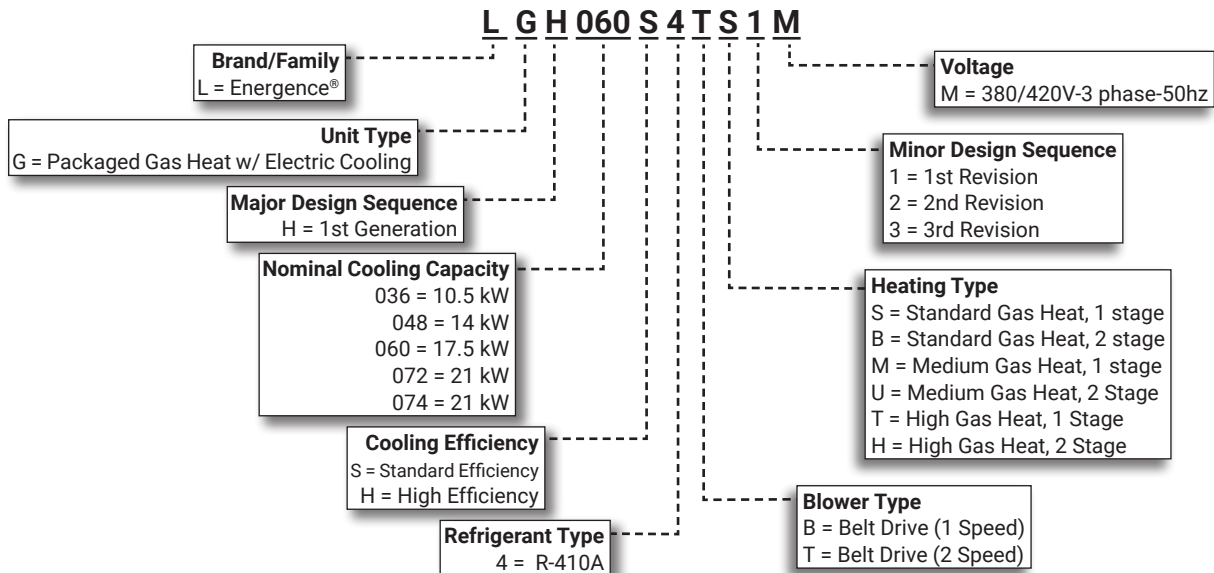

FEATURE HIGHLIGHTS

Lennox' Energence® packaged rooftop unit product line was created to save energy with intelligence by offering some of the highest energy efficiency ratings available with a powerful, easy to use unit controller. This makes Energence® rooftop units perfect for business owners looking for a Heating, Ventilation, and Air Conditioning (HVAC) product with the lowest total cost of ownership.

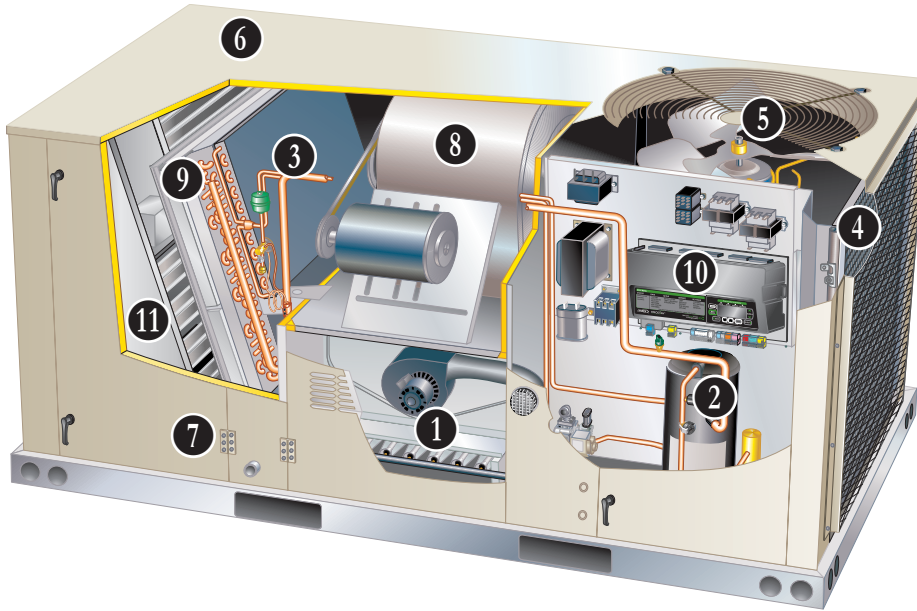

1. Aluminized Steel Inshot Burners
2. Two-Stage Compressor
3. Filter/Drier
4. Lennox' Environ™ Coil System
5. Outdoor Coil Fan Motor
6. Heavy Gauge Steel Cabinet
7. Hinged Access Panels
8. Supply Air Blower
9. Air Filters
10. Prodigy® Control System
11. Economizer (option)

CONTENTS

Blower Data	29
Control System	7
Cooling Ratings	22
Dimensions - Accessories	42
Dimensions - Unit	41
Electrical Data	39
Feature Highlights	2
Features And Benefits	3
Humiditrol® Dehumidification System Option	11
Humiditrol® Dehumidification System Ratings	27
Model Number Identification	1
Optional Conventional Temperature Control Systems	12
Options / Accessories	17
Outdoor Sound Data	40
Sequence Of Operation	14
Specifications	20
Specifications - Gas Heat	21
Unit Clearances	39
Weight Data	40

PERFORMANCE/QUALITY AND CE MARK OPTION

PERFORMANCE/QUALITY

- Cooling performance is rated at test conditions included in Air-Conditioning, Heating and Refrigeration Institute (AHRI) Standard 210/240 (036 thru 060) or 340/360 (072/074) while operating at rated voltage and air volumes
- Components bonded for grounding to meet safety standards for servicing required by Underwriters Laboratories (UL) and the International Electrotechnical Commission (IEC)
- International Organization for Standardization (ISO) 9001 Registered Manufacturing Quality System

CE MARK OPTION

- The CE mark has been added to our rooftop product line as a configure to order (CTO) option
- Optional construction allows units to be sold into countries requiring CE marking for rooftop products
- CE marked units meet the requirements of the Machinery Directive 2006/42/EC, Low Voltage Directive 73/23/EEC, EMC Directive 89/336/EEC, and Gas Directive 90/396/EEC
- Declaration of conformity certificates will be provided for each CE marked unit on demand
- Key features of this option over and above standard product features are:
 - Touch-proof electrical components meeting the requirements of EN 60529
 - Branch circuits over 0.5 kW load have overcurrent protection
 - Rotary style/finger safe disconnect switch with locking handle prevents disconnect door from being opened with the power on
 - Padlock can be applied to lock the disconnect switch in the OFF position
 - The factory wiring has been redesigned for separation of high and low voltage circuits



FEATURES AND BENEFITS

HEATING SYSTEM

1. Aluminized steel inshot burners
 - Direct spark ignition
 - Electronic flame sensor
 - Combustion air inducer
 - Redundant automatic single or dual stage gas valve with manual shut-off

Heat Exchanger

- Tubular construction
- Aluminized steel
- Life cycle tested

NOTE - Stainless Steel Heat Exchanger is required if mixed air temperature is below 7°C.

Limit Controls

- Factory installed
- Redundant limit controls with fixed temperature setting
- Protect heat exchanger and other components from overheating

Safety Switches

- Flame roll-out switch
- Flame sensor and combustion air inducer proving switch protects system operation
- All safety switches are monitored by the Prodigy 2.0 Unit Controller and diagnostic information is reported and recorded

Required Selections

Gas Input Choice - Order one:

- Standard Gas Heat, 1 Stage (16.7 kW)
- Standard Gas Heat, 2 Stage (16.7 kW)
- Medium Gas Heat, 1 Stage (27.8 kW)
- Medium Gas Heat, 2 Stage (20.8/27.8 kW)
- High Gas Heat, 1 Stage (38.7 kW)
- High Gas Heat, 2 Stage (29.0/38.7 kW)

Options/Accessories

Factory Installed

Stainless Steel Heat Exchanger

- Required if mixed air temperature is below 7°C

Factory or Field Installed

Low Temperature Vestibule Heater

- Extends gas heat operation from -40°C (standard) down to -51°C
- Electric heater automatically controls minimum temperature in gas burner compartment when temperature falls below -40°C

Field Installed

Combustion Air Intake Extensions

- Recommended for use with existing flue extension kits in areas where high snow can block intake air

FEATURES AND BENEFITS

HEATING SYSTEM (continued)

Options/Accessories (continued)

Field Installed (continued)

LPG/Propane Kits

- Conversion kit to field change over units from Natural Gas to LPG/Propane

Vertical Vent Extension Kit

- Use to exhaust flue gases vertically above unit
- Required when unit vent is too close to fresh air intakes per building codes
- Prevents ice formation on intake louvers
- Kit contains vent transition, drain cap and installation hardware

NOTE - Straight vent pipe (51 mm B-Vent), vent tee and vent cap are not furnished and must be field supplied. Refer to kit instructions for additional information.

COOLING SYSTEM

- Designed to maximize sensible and latent cooling performance at design conditions
- System can operate from -18°C to 52°C without any additional controls

RR-410A Refrigerant

- Non-chlorine based
- Ozone friendly

2 Two-Stage Compressor (10.5 to 17.5 kW and 21 kW 074 Models)

- Scroll compressors on all models for high performance, reliability, and quiet operation
 - Two-stage scroll compressors are furnished on 10.5 to 17.5 kW and 21 kW (074) models for increased part load efficiency
 - Single speed scroll furnished on 21 kW (072) models
- Resiliently mounted on rubber grommets for quiet operation

Compressor Crankcase Heater

- Protects against refrigerant migration that can occur during low ambient operation or during extended off cycles

Thermal Expansion Valve

- Ensures optimal performance throughout the application range
- Removable element head

3 Filter/Drier

- High capacity filter/drier protects the system from dirt and moisture

High Pressure Switch

- Protects the compressor from overload conditions such as dirty condenser coils, blocked refrigerant flow, or loss of outdoor fan operation

Low Pressure Switch

- Protects the compressor from low pressure conditions such as low refrigerant charge, or low/no airflow

Freezestat

- Protects the evaporator coil from damaging ice build-up due to conditions such as low/no airflow, or low refrigerant charge

4 Condenser Coil - Lennox' Environ™ Coil System

- Lightweight, all aluminum brazed fin construction
- Constructed of three components:
 - A flat extrusion tube
 - Fins in-between the flat extrusion tube
 - Two refrigerant manifolds

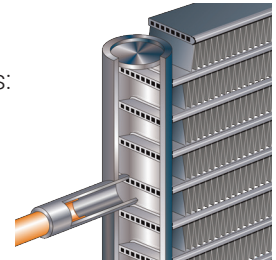

Environ™ Coil System Features:

- Improved heat transfer performance due to high primary surface area (flat tubes) versus secondary surface (fins)
- Smaller internal volume (reduced refrigerant charge)
- All aluminum construction
- Fewer brazed joints
- Compact design
- Easy maintenance/cleaning
- Face-split design
- Mounting brackets with rubber inserts

Evaporator Coil

- Copper tube construction
- Enhanced rippled-edge aluminum fins
- Flared shoulder tubing connections
- Silver soldered construction
- Factory leak tested
- Cross row circuiting with rifled tubing

Condensate Drain Pan

- Plastic pan with positive slope
- Side or bottom drain connections
- Reversible to allow connection at back of unit

5 Outdoor Coil Fan Motor

- Thermal overload protected
- Totally enclosed
- Permanently lubricated sleeve bearings (036 and 048 models)
- Permanently lubricated ball bearings (060, 072, and 074 models)
- Shaft up
- Wire basket mount

Outdoor Coil Fan

- Polyvinyl chloride (PVC) coated fan guard furnished

FEATURES AND BENEFITS

COOLING SYSTEM (continued)

Required Selections

Cooling Capacity

- Specify nominal cooling capacity

Options/Accessories

Factory Installed

Conventional Fin/Tube Condenser Coil (replaces Environ™ Coil System)

- Copper tube construction
- Enhanced rippled-edge aluminum fins
- Flared shoulder tubing connections
- Silver soldered construction

Service Valves

- Fully serviceable brass valves installed in discharge & liquid lines

NOTE - Not available for units equipped with Environ™ Coil System or Humiditrol Dehumidification option.

Factory or Field Installed

Condensate Drain Trap

- Available in copper or polyvinyl chloride (PVC)

NOTE - Factory installed option is shipped with the unit for field installation.

Drain Pan Overflow Switch

- Monitors condensate level in drain pan
- Shuts down unit if drain becomes clogged

CABINET

6 Construction

- Heavy-gauge steel panels
- Full perimeter heavy-gauge galvanized steel base rail
- Base rails have rigging holes
- Three sides of the base rail have forklift slots
- Raised edges around duct and power entry openings in the bottom of the unit for water protection

Airflow Choice

- Units are shipped in downflow (vertical) return air flow configuration
- Can be field converted to horizontal air flow configuration without the need of a kit

Duct Flanges

- Provided for horizontal duct attachment

Power/Gas Entry

- Electrical and gas lines can be brought through the unit base or through horizontal access knock-outs

Exterior Panels

- Constructed of heavy-gauge, galvanized steel
- Two-layer enamel paint finish

Insulation

- Fully insulated with non-hygroscopic fiberglass insulation (conditioned areas)
- Unit base is fully insulated
- Base insulation serves as an air seal to the roof curb, eliminating the need to add a seal during installation

7 Access Panels

- Tool-less access
- Filter section
- Blower/heating section
- Compressor/controls section
- Panel seals and quarter-turn latching handles provide a tight air and water seal

NOTE - 060/072/074 models include a filler panel for proper cabinet fit for optional accessories (Economizers, Power Exhaust, Outdoor Air Dampers and Barometric Relief Dampers).

Required Selections

Airflow Configuration

- Specify downflow or horizontal

FEATURES AND BENEFITS

CABINET (continued)

Options/Accessories

Factory Installed

Corrosion Protection

- Completely flexible immersed coating
- Electrodeposited dry film process
- AST ElectroFin E-Coat
- Meets Mil Spec MIL-P-53084, ASTM B117 Standard Method Salt Spray Testing
- Indoor Corrosion Protection:
 - Coated coil
 - Coated reheat coil (Humiditrol®)
 - Painted blower housing
 - Painted base
- Outdoor Corrosion Protection:
 - Coated coil
 - Painted outdoor base

Field Installed

Combination Coil/Hail Guards

- Heavy gauge steel frame
- Painted to match cabinet
- Expanded metal mesh to protect the outdoor coil

BLOWER

- A wide selection of supply air blower options are available to meet a variety of airflow requirements

Blower Motor Choice

- Overload protected
- Ball bearings
- Two-speed belt drive motors (low static/high static) available on 036, 048, 060 and 074 models in several different sizes to maximize air performance
- Single-speed belt drive motor is available on 072 models

8 Supply Air Blower

- Forward curved blades
- Blower wheel statically and dynamically balanced
- Belt drive motors have adjustable pulley for speed change

Ordering Information

- Specify motor kW and drive kit number when base unit is ordered

Required Selections

- Order one drive kit
- See Drive Kit Specifications Table

ELECTRICAL

SmartWire™ System

- Keyed and color-coded wiring connectors prevent miswiring
- Wire coloring scheme is standardized across all models
- Each connection is intuitively labeled to make troubleshooting and servicing quick and easy

Electrical Plugs

- Positive connection electrical plugs are used to connect common accessories or maintenance parts for easy removal or installation

INDOOR AIR QUALITY

9 Air Filters

- Disposable 51 mm filters furnished as standard

Option/Accessories

Factory or Field Installed

Healthy Climate® High Efficiency Air Filters

Disposable MERV 8 or MERV 13 (Minimum Efficiency Reporting Value based on ASHRAE 52.2) efficiency 51 mm pleated filters

Field Installed

Healthy Climate® UVC Germicidal Lamps

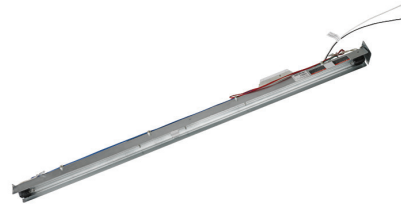

- Germicidal lamps emit ultra-violet (UV-C) energy, which has been proven to be effective in reducing microbes such as viruses, bacteria, yeasts, and molds
- This process either destroys the organism or controls its ability to reproduce
- UV-C energy greatly reduces the growth and proliferation of mold and other bioaerosols (bacteria and viruses) on illuminated surfaces (particularly coil and drain pan)
- Field installed in the blower/evaporator coil section
- Magnetic safety interlock terminates power when access panels are removed
- All necessary hardware for installation is included
- Lamps operate on 220V-1ph power supply

NOTE - Step-down transformer must be field supplied for field installation for 380/420V primary to 220V secondary.

Indoor Air Quality (CO₂) Sensors

- Monitors CO₂ levels
- Reports to the Prodigy 2.0 unit controller, which adjusts economizer dampers as needed

CONTROL SYSTEM

PRODIGY 2.0 UNIT CONTROLLER



10 The Prodigy 2.0 unit controller is a microprocessor-based controller that provides flexible control of all unit functions.

Features:

- LCD Display
- Easy to read menu (4 lines x 20 character display)
- Buttons for menu navigation during setup and diagnostic
- Menu navigation LEDs for Data, Setup, Service, Settings
- Main Menu and Help Buttons for quick navigation to home screen and built-in help functions
- Scroll, Value Adjustment Select and Save Buttons
- Setup menu ensures proper installation and simplified setup of the rooftop unit
- Profile setup copies key settings between units with the same configuration to reduce setup time
- USB port allows a technician to download and transfer unit information to help verify service was performed
- USB software updates on the Prodigy Control System enhance functionality without the need to change components
- Unit Controller Software
- Unit self-test verifies individual critical component and system performance
- Economizer test function assures economizer is operating correctly
- Time Clock with Run-Time Information

Built-In Functions Include:

- Adjustable Blower On/Off Delay
- Built-in Control Parameter Defaults
- Compressor Time-Off Delay
- DDC Compatible
- Dirty Filter Switch Input
- Discharge Air Temperature Control
- Display/Sensor Readout
- Economizer Control Options
(See Economizer / Exhaust Air / Outdoor Air sections)
- Fresh Air Tempering
- Over 100 diagnostic and status messages in English
- Exhaust Fan Control Modes for fresh air damper position
- Permanent Diagnostic Code Storage
- Field Adjustable Control Parameters (Over 200 settings)
- Indoor Air Quality Input (Demand Control Ventilation)
- Low Ambient Controls for cooling operation down to -17°C

- Gas Valve Time Delay Between First and Second Stage
- Minimum Compressor Run Time
- Network Capable
(Can be daisy chained to other units or controls)
- Night Setback Mode
- Return Air Temperature Limit Control
- Safety Switch Input allows Controller to respond to a external safety switch trip
- Service Relay Output
- Smoke Alarm Mode has four choices (unit off, positive pressure, negative pressure, purge)
- Up to 2 heat/2 cool (standard Prodigy® unit controller thermostat input)
- Up to 3 cool with additional relay
- Up to 4 cool with room sensor or network operation
- “Strike Three” Protection
- Gas Reheat Control allows simultaneous heating and cooling operation for humidity control of process air applications such as supermarkets
- On Demand Dehumidification monitors and controls condenser hot gas reheat operation with Humiditrol® dehumidification option
- Thermostat Bounce Delay
- Warm Up Mode Delay
- LED Indicators
- PC Interface connects the Prodigy 2.0 unit controller to a PC with the Lennox Unit Controller Software
- Room Sensor Operation controls temperature

NOTE - Prodigy® Control System features vary with the type of rooftop unit in which the control is installed.

NOTE - See separate Prodigy® Control System Product Specifications Bulletin for additional information.

CONTROL SYSTEM

PRODIGY 2.0 UNIT CONTROLLER (continued)

Options / Accessories

Factory or Field Installed

Blower Proving Switch

- Monitors blower operation, shuts down unit if blower fails

Dirty Filter Switch

- Senses static pressure increase indicating dirty filter condition

Control Options

Factory or Field Installed

Fresh Air Tempering

- Used in applications with high outside air requirements
- Controller energizes the first stage heat as needed to maintain a minimum supply air temperature for comfort, regardless of the thermostat demand
- When ordered as a factory option, sensor ships with the unit for field installation

Smoke Detector

- Photoelectric type
- Installed in supply air section, return air section or both sections
- Available with power board and single sensor (supply or return) or power board and two sensors (supply and return)
- Power board located in unit control compartment

Interoperability via BACnet® or LonTalk® Protocols

- Communication compatible with third-party automation systems that support the BACnet Application Specific Controller device profile, LonMark® Space Comfort Controller functional profile, or LonMark Discharge Air Controller functional profile

Commercial Control Systems

After-Market DDC

- Novar® Unit Controller and options

Thermostats

- Control system and thermostat options
- After-Market unit controller options

Field Installed

General Purpose Control Kit

- Plug-in control provides additional analog and digital inputs/outputs for field installed options

Humidity Sensor Kit

- Humidity sensor required with factory installed Humiditrol® Dehumidification Option or Supermarket reheat field selectable option

OPTIONS / ACCESSORIES

ECONOMIZER

- 11 Economizer operation is set and controlled by the Prodigy 2.0 Unit Controller

- Standard and High Performance Models available
- Simple plug-in connections from economizer to unit controller for easy installation

NOTE - Optional sensors may be used instead of unit sensors to determine whether outdoor air is suitable for free cooling.

Factory or Field Installed

High Performance Economizer

- Combination Outdoor Air Hood is furnished
- Factory installed Economizer can be ordered with three exhaust options
 1. Barometric Relief Dampers
 2. Power Exhaust Fan

NOTE - See Power Exhaust Fan section for additional requirements.

3. No Exhaust

- Field installed Economizer includes Barometric Relief Dampers with Combination Hood
- Barometric Relief Dampers allow relief of excess air
- Dampers prevent blow back and outdoor air infiltration during off cycle
- Bird screen furnished

NOTE - Barometric Relief Dampers are required when Economizer is factory installed with field or factory installed Power Exhaust Fan option. See Power Exhaust Fan section and Options/Accessories table.

- Demand Control Ventilation (DCV) ready using optional CO₂ sensors

NOTE - Horizontal Economizer Conversion kit is available for field installation.

NOTE - Horizontal Barometric Dampers are required for horizontal Economizer applications and must be ordered separately.

- Gear-driven action
- High torque 24-volt fully-modulating spring return damper motor
- Return air and outdoor air dampers
- Plug-in connections to unit
- Nylon bearings
- Enhanced thermoplastic vulcanizate (TPV) blade edge seals
- Flexible stainless steel jamb seals

NOTE - Refer to Installation Instructions for complete setup information.

OPTIONS / ACCESSORIES

ECONOMIZER (continued)

Factory or Field Installed

Differential Sensible Control

- Factory setting
- Uses outdoor air and return air sensors that are furnished with the unit
- The Prodigy 2.0 Unit Controller compares outdoor air temperature and return air
- Engages the economizer when the outdoor air temperature is below the configured setpoint and cooler than return air

NOTE - Differential Sensible Control can be configured in the field to provide Offset Differential Sensible Control or Single Sensible Control.

NOTE - In Offset Differential Sensible Control mode, the economizer is enabled if the temperature differential (offset) between outdoor air and return air reaches the configured setpoint. In Single Sensible Control mode, the economizer is enabled when outdoor air temperature falls below the configured setpoint.

Global Control

- The unit controller communicates with a DDC system with one global sensor (enthalpy or sensible)
- Determines whether outside air is suitable for free cooling on all units connected to the control system
- Sensor must be field provided

Single Enthalpy Temperature Control

- Outdoor air enthalpy sensor enables Economizer if the outdoor enthalpy is less than the setpoint of the control

Differential Enthalpy Control

- Order two Single Enthalpy Controls:
 - One is field installed in the return air section
 - One is installed in the outdoor air section
- Allows the economizer control to select between outdoor air or return air, whichever has lower enthalpy

Field Installed

Building Pressure Control

- Maintains constant building pressure level
- Includes a static pressure transducer and outdoor static pressure assembly
- Using differential pressure information between the outdoor air and the building air, the Prodigy 2.0 unit controller changes the economizer position to help maintain a constant building pressure

NOTE - Not available with Demand Control Ventilation (CO₂ Sensor).

Horizontal Barometric Relief Dampers

- For use when unit is configured for horizontal applications with an Economizer
- Allows relief of excess air
- Blade type dampers prevent blow back and outdoor air infiltration during off cycle
- Field installed in return air duct
- Exhaust hood with bird screen furnished

NOTE - Requires Horizontal Economizer Conversion Kit.

Horizontal Economizer Conversion Kit

- Insulated panel covers the bottom return air opening on the unit base to convert downflow Economizer to horizontal air flow

EXHAUST

Factory or Field Installed

Power Exhaust Fan

- Installs internally for downflow applications with economizer option
- Provides exhaust air pressure relief
- Interlocked to run when supply air blower is operating, fan runs when outdoor air dampers are 50% open (adjustable)
- Motor is overload protected
- 406 mm diameter fan
- 4 fan blades
- 0.25 kW motor

NOTE - If Power Exhaust is field installed with a factory installed Economizer, the Economizer must be ordered with No Exhaust option. Barometric Relief Dampers must also be ordered separately for field installation.

NOTE - If Power Exhaust is factory installed with a factory installed Economizer, Barometric Relief Dampers must also be ordered separately for field installation.

OUTDOOR AIR

Factory or Field Installed

Outdoor Air Dampers - Downflow or Horizontal

- Single blade damper
- 0 to 25% (fixed) outdoor air adjustable; installs in unit
- Automatic model features fully modulating spring return damper motor with plug-in connection
- Manual model features a slide damper
- Maximum mixed air temperature in cooling mode: 38°C
- Outdoor Air Hood is furnished

OPTIONS / ACCESSORIES

ROOF CURBS

- Nailer strip furnished
- Mates to unit
- US National Roofing Contractors Approved
- Shipped knocked down

Hybrid Roof Curbs

- Downflow
- Roof curb can be assembled using interlocking tabs to fasten corners together
- No tools required
- Curb can also be fastened together with furnished hardware
- Available in 203, 356, 457, and 610 mm heights

Adjustable Pitch Curb

- Downflow
- Fully adjustable pitch curb provides a level platform for rooftop units allowing flexible installations on roofs with uneven or sloped angles
- Maximum slope is 19 mm per 300 mm in any direction
- Uses interlocking tabs to fasten corners together; no tools required
- Hardware is furnished to connect upper curb with lower curb
- Available in 356 mm height

Adaptor Curbs (not shown)

- Curbs are regionally sourced
- Dimensions will vary based upon the source

NOTE - Contact your local sales representative for a detailed cut sheet with applicable dimensions.

CEILING DIFFUSERS

Ceiling Diffusers (Flush or Step-Down)

- White powder coat finish on diffuser face and grilles
- Insulated UL listed duct liner
- Diffuser box has collars for duct connection
- Step-down diffusers have double deflection blades
- Flush diffusers have fixed blades
- Provisions for suspending
- Internally sealed to prevent recirculation
- Removable return air grille
- Adapts to T-bar ceiling grids or plaster ceilings

Transitions (Supply and Return)

- Used with diffusers
- Installs in roof curb
- Galvanized steel construction
- Flanges furnished for duct connection to diffusers
- Fully insulated

HUMIDITROL® DEHUMIDIFICATION SYSTEM OPTION

OVERVIEW

- Factory installed option designed to control humidity
- Provides dehumidification on demand using American Society of Heating, Refrigeration and Air Conditioning Engineers (ASHRAE) 90.1 recommended method for comfort conditioning humidity control
- Unit comes equipped with one row reheat coil, solenoid valve and humidity controller
- A humidity sensor is required and must be located in the occupied space

NOTE - Remote Mounted Humidity Sensor Kit is required for field installation.

- Humidity sensor provides input to the Unit Controller, which is used to control activation of the dehumidification operation
- Reheat controls are located in the compressor control section of the unit for easy access

BENEFITS

- Improves indoor air quality
- Helps prevent damage due to high humidity levels
- Improves comfort levels by reducing space humidity levels

OPERATION

No Dehumidification Demand

- The unit will operate conventionally whenever there is a demand for cooling or heating and no dehumidification demand
- Free cooling is only permitted when there is no demand for dehumidification

Dehumidification Demand Only

- The Unit Controller is factory set at 60% relative humidity setpoint and can be adjusted at the Unit Controller or with optional Unit Controller Software
- Reheat operation will initiate on a dehumidification demand and does not require a cooling demand
- The unit will operate in the dehumidification mode until the relative humidity of the conditioned space is below the setpoint
- The reheat coil is sized to provide 20°C to 24°C supply air during reheat operation
- This reduces sensible cooling capacity and extends compressor run time to control humidity when the cooling load is low
- A solenoid valve diverts hot gas from the compressor to the reheat coil
- The cooled and dehumidified air from the evaporator is reheated as it passes through the reheat coil

- The de-superheated and partially condensed refrigerant continues to the outdoor condenser coil where condensing is completed
- Unit will continue to operate in this mode until the dehumidification demand is satisfied

NOTE - See Sequence of Operation for additional information.

Dehumidification and Cooling Demand (Thermostat/ Room Sensor Application)

Two-stage compressor models (036, 048, 060, 074)

- If both a dehumidification and a 1st stage cooling demand occur, the system will operate in the full cooling mode at first stage indoor air flow. If a 2nd stage cooling demand occurs along with a dehumidification demand, the system operates in full cooling mode at full cooling airflow until the 2nd stage cooling demand is satisfied. Then the system will revert to the dehumidification mode if a dehumidification mode demand is present

Single speed compressor model (072H)

- If both a dehumidification and a cooling demand occur, the system will operate in cooling until the cooling demand is satisfied; then the system will start the dehumidification mode

Options/Accessories

Humidity Sensor Kit

- Remote mounted dehumidistat for factory installed Humiditrol® option or Supermarket reheat field selectable option

TYPICAL DEHUMIDIFICATION SCHEMATIC

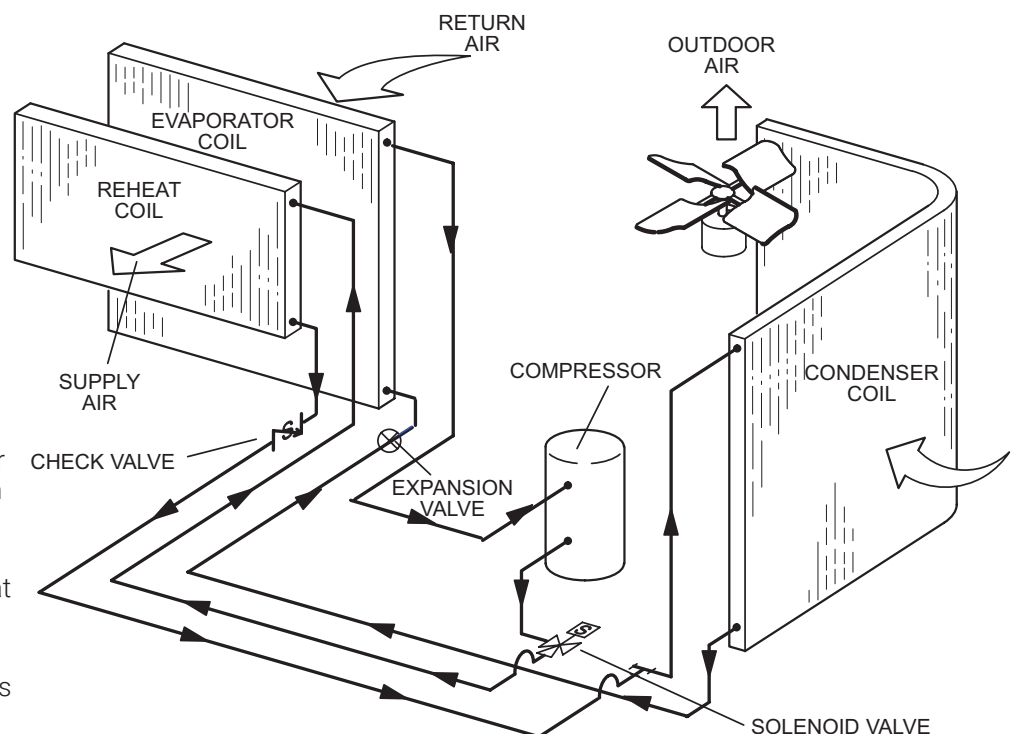

OPTIONAL CONVENTIONAL TEMPERATURE CONTROL SYSTEMS

ComfortSense® 8500 Commercial 7-Day Programmable Thermostat

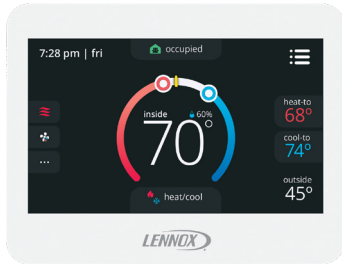

- Fully Communicating Sensor
- Full Color Touchscreen Interface
- Variable Speed System Control (On Compatible Units)
- Up To 4 Heat / 4 Cool
- Built-In Sensors For Temperature, Humidity And Optional CO₂
- Remote Sensor Options For Occupancy, Temperature
- BACnet Capable Options
- 5-2 or 7-Day Scheduling
- Smooth Setback Recovery
- Heat/Cool Auto-Changeover
- Four-Wire Installation
- FDD, ASHRAE, IECC Compliant

ComfortSense® 7500 Commercial 7-Day Programmable Thermostat



- Premium Universal Thermostat
- Full Color Touchscreen Interface
- Up To 4 Heat / 4 Cool
- Built-In Sensors For Temperature and Humidity
- Remote Sensors Options For Temperature, Discharge Air, Outdoor Air
- 5-2 or 7-Day Scheduling
- Smooth Setback Recovery
- Heat/Cool Auto-Changeover
- FDD, ASHRAE, IECC Compliant

ComfortSense® 3000 Commercial 5-2 Day Programmable Thermostat



- Conventional Multi-Stage Thermostat
- Intuitive Display
- Push-Button Operation
- Up To 2 Heat / 2 Cool
- Built-In Temperature Sensor
- Remote Temperature Sensing
- Up to 5-2 Day Scheduling
- Smooth Setback Recovery
- Heat/Cool Auto-changeover

Wired Room Sensor (LCS-5030)



- Simple Push-Button Override
- Variable Speed System Control (On Compatible Units)
- Up To 4 Heat / 4 Cool
- Built-In Temperature and Humidity Sensors
- AA Battery / 24VAC Powered
- SBUS Wired Operation
- Automatic Sensor Averaging
- Locking Hex Screw

OPTIONAL CONVENTIONAL TEMPERATURE CONTROL SYSTEMS

Description	Catalog No.
ComfortSense® 8500 Commercial 7 Day Programmable Thermostat	
CS8500 7-Day Thermostat	No CO ₂ Sensing 17G75
	With CO ₂ Sensing 17G76
Sensors/Accessories	¹ Remote non-adjustable wall-mount 10k 47W37
	¹ Remote non-adjustable wall-mount 11k 94L61
Sysbus Network Cable (Yellow) for ComfortSense 8500 and LCS-5030 Wired Room Sensor	
Twisted pair 100% shielded communication cable, Red and Black	500 ft. box 27M19
22 AWG, yellow jacket, rated at 75°C, 300V, Plenum rated	1000 ft. box 94L63
Insulation - Low smoke PVC, NEC, CMP	2500 ft. roll 68M25
ComfortSense® 7500 Commercial 7-Day Programmable Thermostat	
CS7500 7-Day Thermostat	17G74
Sensors/Accessories	² Remote non-adjustable wall-mount 20k 47W36
	² Remote non-adjustable wall-mount 10k 47W37
	Remote non-adjustable discharge air (duct mount) 19L22
	Outdoor temperature sensor X2658
ComfortSense® 3000 Commercial 5-2 Day Programmable Thermostat	
CS3000 5-2 Day Thermostat	11Y05
Sensors/Accessories	Remote non-adjustable wall mount 10k averaging 47W37
	Thermostat wall mounting plate X2659
ComfortSense® Non-Programmable Thermostat	
CS3000 Non-Programmable Thermostat	51M32
Universal Thermostat Guard with Lock (clear)	
	Inside Dimensions (H x W) 5 7/8 x 8 3/8 in. 39P21
Wired Room Sensor	
LCS-5030 Wired Room Sensor	21L07

¹ Up to nine of the same type remote temperature sensors can be connected in parallel.

² Remote wall-mount sensors can be applied in any of the following combinations:
 One Sensor - (1) 47W36, Two Sensors - (2) 47W37, Three Sensors - (2) 47W36 and (1) 47W37
 Four Sensors - (4) 47W36, Five Sensors - (3) 47W36 and (2) 47W37

Objective: Outline the unit functions as a result of room thermostat or zone sensor demands.

Given: When economizer is present, it will function as initial part of the unit cooling system. When not present, unit will function as if outdoor ambient is high and sensed as not suitable.

BELT DRIVE SYSTEM OPERATION (036 THROUGH 060 AND 074 MODELS):

Modulating Outdoor Air Damper:

Damper minimum positions #1 and 2 are adjusted during unit setup to provide minimum fresh air requirements at the indicated supply fan speeds per American Society of Heating, Refrigeration, and Air Conditioning Engineers (ASHRAE) 62.1.

- Supply fan is off and the outdoor air damper is closed
- Supply fan is on low speed and the outdoor air damper is at minimum position 1
- Supply fan is on high speed and the outdoor air damper is at minimum position 2

¹Unit Features an Economizer and Outdoor Air is Suitable

Cooling - Thermostat or Zone Sensor Mode (Up to 3 stages Y1, Y2, Y3)

Y1 Demand:

Compressor is off, supply fan is on low speed, economizer modulates (minimum to maximum open position) to maintain 13°C supply air temperature (default unit controller setting)

After 5 minutes (default unit controller setting), supply fan switches to high speed. Economizer continues modulating with supply fan on high speed to maintain 13°C supply air temperature

Y2 Demand:

Compressor is off, supply fan is on high speed, and economizer modulates to maintain 13°C supply air temperature

Economizer opens to maximum. If economizer stays at maximum open for 3 minutes (default unit controller setting) compressor is energized and operates at first stage while supply fan stays on high speed

¹ Outdoor air suitability is determined by the energy state of outdoor ambient (enthalpy or sensible) and its ability to achieve the desired free cooling effects. Outdoor air suitability can also be determined by a third party controller and provided to the rooftop unit (RTU) via a network connection.

Y3 Demand:

Economizer is at maximum open and compressor operates at first stage. If economizer stays at maximum open for 3 minutes (default unit controller setting) compressor switches to second stage operation while supply fan stays on high speed

Unit Does Not Feature an Economizer (or Outdoor Air Is Not Suitable)

Cooling - Thermostat or Zone Sensor (Up to 2 stages Y1, Y2)

Y1 Demand:

Compressor operates at first stage and supply fan operates at low speed

Y2 Demand:

Compressor operates at second stage and supply fan operates at high speed

(Continued on Next Page)

BELT DRIVE SYSTEM OPERATION (036 THROUGH 060 AND 074 MODELS) (CONTINUED):**Dehumidification Mode (economizer free cooling is locked out):**

Unit features the Humiditrol® dehumidification system

No Y1, Y2 Demand but a call for dehumidification:

Compressor operates at second stage, supply fan operates at low speed, and the reheat valve is energized

Y1 Demand:

Compressor operates at second stage, outdoor fan operates at high speed, supply fan operates at low speed and the reheat valve is de-energized

Y2 Demand:

Compressor operates at second stage, supply fan operates at high speed, and the reheat valve is de-energized

Heating mode: Thermostat or Zone Sensor (Up to 2 stages W1, W2)**W1 Demand:**

Gas valve is open (stage 1 on units with 2 stage gas valve) and the supply fan operates at high speed

W2 Demand:

Gas valve is open (stage 2 on units with 2 stage gas valve) and the supply fan operates at high speed

SINGLE STAGE UNIT OPERATION (072)**Modulating Outdoor Air Damper:**

Damper minimum positions are adjusted during unit setup to provide minimum fresh air requirements at the indicated supply fan speeds per American Society of Heating, Refrigeration, and Air Conditioning Engineers (ASHRAE) 62.1.

- Supply fan is off and the outdoor air damper is closed
- Supply fan is on and the outdoor air damper is at minimum position

¹ Unit Features an Economizer and Outdoor Air is Suitable

Cooling - Thermostat or Zone Sensor (Up to 2 stages Y1, Y2)

Y1 Demand:

Compressor is off, supply fan is on, economizer modulates (minimum to maximum open position) to maintain 13°C supply air temperature (default unit controller setting)

Y2 Demand:

Economizer goes to maximum open position and if the damper stays open for three minutes (default unit controller setting) the compressor is energized

Unit Does Not Feature an Economizer (or outdoor air is not suitable)

Cooling - Thermostat or Zone Sensor (Up to 1 stage Y1)

Y1 Demand:

Compressor is operating and supply fan is on

Dehumidification Mode (economizer free cooling is locked out):**Unit Features the Humiditrol® Dehumidification System****No Y1 Demand but a call for dehumidification:**

Compressor is operating, supply fan is on, and the reheat valve is energized

Y1 Demand:

Compressor is operating, supply fan is on, and the reheat valve is de-energized

Y2 Demand:

Compressor is operating, supply fan is on, and the reheat valve is de-energized

Heating Mode Thermostat or Zone Sensor (Up to 2 stages W1, W2)**W1 Demand:**

Gas valve is open (stage 1 on units with 2 stage gas valve), supply fan is on

W2 Demand:

Gas valve is open (stage 2 on units with 2 stage gas valve), supply fan is on

OPTIONS / ACCESSORIES

Item	Model Number	Catalog Number	Unit				
			036	048	060	072	074
CE MARK							
CE Marked Unit		Factory	O	O	O	O	O
COOLING SYSTEM							
Condensate Drain Trap	Polyvinyl Chloride (PVC) - C1TRAP20AD2	22H54	OX	OX	OX	OX	OX
	Copper - C1TRAP10AD2	76W27	OX	OX	OX	OX	OX
Drain Pan Overflow Switch	E1SNSR71AD1	21Z07	OX	OX	OX	OX	OX
Efficiency	Standard	Factory	O	O	O		
	High	Factory				O	O
Service valves (not for Environ™ Coil System or Humiditrol equipped units)		Factory	O	O	O	O	O
HEATING SYSTEM							
Bottom Gas Piping Kit	T1GPKT01AN1	19W50	OX	OX	OX	OX	OX
Combustion Air Intake Extensions	T1EXTN10AN1	19W51	X	X	X	X	X
Gas Heat Input	Standard One-Stage - 16.7 kW input	Factory	O	O	O	O	O
	Standard Two-Stage - 12.6/16.7 input	Factory	O	O	O	O	O
	Medium One-Stage - 27.8 kW input	Factory	O	O	O	O	O
	Medium Two-Stage - 20.8/27.8 kW input	Factory	O	O	O	O	O
	High One-Stage - 38.7 kW input	Factory		O	O	O	O
	High Two-Stage - 29.0/38.7 kW input	Factory		O	O	O	O
LPG/Propane Conversion Kits	For one-stage models - C1PROP10AP2	21Z22	X	X	X	X	X
	For two-stage models - C1PROP20AP2	21Z23	X	X	X	X	X
Stainless Steel Heat Exchanger		Factory	O	O	O	O	O
Vertical Vent Extension	C1EXTN20FF1	31W62	X	X	X	X	X
BLOWER - SUPPLY AIR							
Drive Kits See Blower Data Tables for selection	Belt Drive - 0.47 kW (2 Speed)	Factory	O	O			
	Belt Drive - 0.62 kW (2 Speed)	Factory	O		O		O
	Belt Drive - 1.24 kW (2 Speed)	Factory		O	O		O
	Belt Drive - 0.75 kW (2 Speed)	Factory					O
	Belt Drive - 1.5 kW (2 Speed)	Factory					O
	Belt Drive - 1.5 kW Standard Efficiency	Factory				O	
	Kit A01 - T1DRKT001-1 - 374-842 rev/min	Factory	O				
	Kit A02 - T1DRKT002-1 - 414-931 rev/min	Factory		O			
	Kit A03 - T1DRKT003-1 - 463-1042 rev/min	Factory			O		
	Kit A05 - T1DRKT005-1 - 498-1122 rev/min	Factory	O				
Kit A06 - T1DRKT006-1 - 595-1191 rev/min	Factory		O				
Kit A07 - T1DRKT007-1 - 673-1290 rev/min	Factory			O			
Kit AA02 - T1DRKT002AP1 - 527-729 rev/min	Factory				O		
Kit AA03 - T1DRKT003AP1 - 665-921 rev/min	Factory				O	O	
Kit AA04 - T1DRKT004AP1 - 768-1023 rev/min	Factory				O	O	
CABINET							
Combination Coil/Hail Guards	C1GARD51A-1	13R98	X	X			
	C1GARD51AT1	13T03			X	X	X
Corrosion Protection (indoor coil / outdoor coil)		Factory	O	O	O	O	O

NOTE - Catalog and model numbers shown are for ordering field installed accessories.

OX - Configure To Order (Factory Installed) or Field Installed

O = Configure To Order (Factory Installed)

X = Field Installed

OPTIONS / ACCESSORIES

Item	Model Number	Catalog Number	Unit				
			036	048	060	072	074
CONTROLS							
Blower Proving Switch	C1SNSR35FF1	21Z10	OX	OX	OX	OX	OX
Commercial Controls	Novar® LSE	Factory	O	O	O	O	O
	Novar 2051 - E0CTRL30A1	64W72	OX	OX	OX	OX	OX
	Prodigy® Control System - BACnet® Module - C0CTRL60AE1L	59W51	OX	OX	OX	OX	OX
	Prodigy® Control System - LonTalk® Module - C0CTRL65FF1	54W27	OX	OX	OX	OX	OX
Dirty Filter Switch	E1SNSR55AP1	53W66	OX	OX	OX	OX	OX
General Purpose Control Kit	E1GPBK30C1	13J78	X	X	X	X	X
Fresh Air Tempering	C1SNSR75AD1	21Z08	OX	OX	OX	OX	OX
Smoke Detector - Supply or Return (Power board and one sensor)	C1SNSR44AP1	21Z11	OX	OX	OX	OX	OX
Smoke Detector - Supply and Return (Power board and two sensors)	C1SNSR43AP1	21Z12	OX	OX	OX	OX	OX
ELECTRICAL							
Voltage 50 hz with neutral	380/420V - 3 phase	Factory	O	O	O	O	O
ECONOMIZER							
High Performance Economizer With Outdoor Air Hood (Sensible Control)							
High Performance Economizer - Includes Barometric Relief Dampers with Exhaust Hood	E1ECON17A-2	20H48	OX	OX	OX	OX	OX
High Performance Economizer - No Exhaust Option		Factory	O	O	O	O	O
Economizer Accessories							
Horizontal Economizer Conversion Kit	T1HECK00AN1	17W45	X	X	X	X	X
Economizer Controls							
Differential Enthalpy	Order 2 - C1SNSR64FF1	21Z09	OX	OX	OX	OX	OX
Sensible Control	Sensor is Furnished	Factory	O	O	O	O	O
Single Enthalpy	C1SNSR64FF1	21Z09	OX	OX	OX	OX	OX
Global Control	Sensor Field Provided	Factory	O	O	O	O	O
Building Pressure Control	E1GPBK20C1	13J77	X	X	X	X	X
POWER EXHAUST FAN (DOWNFLOW ONLY)							
Standard Static	380/420V-3ph - C1PWRE10A-1M	21Z16	OX	OX	OX	OX	OX
<i>NOTE - Factory installed Power Exhaust Fan requires "Barometric Relief Dampers for Power Exhaust Kit" for field installation. See below.</i>							
BAROMETRIC RELIEF							
¹ Barometric Relief Dampers for Power Exhaust Kit	C1DAMP50A-3-	21Z21	X	X	X	X	X
² Horizontal Barometric Relief Dampers With Exhaust Hood	LAGEDH03/15-2	19F01	X	X	X	X	X
OUTDOOR AIR							
Outdoor Air Dampers With Outdoor Air Hood							
Motorized	C1DAMP21A-1	15D17	OX	OX	OX	OX	OX
Manual	C1DAMP11A-2	15D18	OX	OX	OX	OX	OX
HUMIDITROL® CONDENSER REHEAT OPTION							
Humiditrol		Factory	O	O	O	O	O
Humidity Sensor Kit, Remote mounted (required)	COSNSR31AE-1	17M50	X	X	X	X	X

¹ Required when Economizer is factory installed with factory or field installed Power Exhaust Fan option.

² Required when Economizer is configured for horizontal airflow.

NOTE - Catalog and model numbers shown are for ordering field installed accessories.

OX - Configure To Order (Factory Installed) or Field Installed

O = Configure To Order (Factory Installed)

X = Field Installed

OPTIONS / ACCESSORIES

Item	Model Number	Catalog Number	Unit				
			036	048	060	072	074
INDOOR AIR QUALITY							
Air Filters							
Healthy Climate® High Efficiency Air Filters	MERV 8 (406 x 508 x 51 mm) - C1FLTR15A-1-	54W20	OX	OX			
	MERV 13 (406 x 508 x 51 mm) - T1FLTR40A-1-	52W37	OX	OX			
Order 4 per unit	MERV 8 (508 x 508 x 51 mm) - C1FLTR15D-1-	54W21			OX	OX	OX
	MERV 13 (508 x 508 x 51 mm) - C1FLTR40D-1-	52W39			OX	OX	OX
Replaceable Media Filter With Metal Mesh Frame (includes non-pleated filter media)	406 x 508 x 51 mm (Order 4) - K1FLTR30A-1	39W09	X	X			
	508 x 508 x 51 mm (Order 4) - K1FLTR30A-2	44N60			X	X	X
Indoor Air Quality (CO₂) Sensors							
Sensor - Wall-mount, off-white plastic cover with LCD display	C0SNSR50AE1L	77N39	X	X	X	X	X
Sensor - Wall-mount, off-white plastic cover, no display	C0SNSR52AE1L	87N53	X	X	X	X	X
Sensor - Black plastic case with LCD display, rated for plenum mounting	C0SNSR51AE1L	87N52	X	X	X	X	X
Sensor - Wall-mount, black plastic case, no display, rated for plenum mounting	C0SNSR53AE1L	87N54	X	X	X	X	X
CO ₂ Sensor Duct Mounting Kit - for downflow applications	C0MISC19AE1-	85L43	X	X	X	X	X
Aspiration Box - for duct mounting non-plenum rated CO ₂ sensors (87N53 or 77N39)	C0MISC16AE1-	90N43	X	X	X	X	X
UVC Germicidal Lamps							
³ Healthy Climate® UVC Light Kit (220V-1ph)	C1UVCL10AN1-	21A92	OX	OX	OX	OX	OX
ROOF CURBS							
Hybrid Roof Curbs, Downflow							
203 mm height	C1CURB70A-1	11F50	X	X	X	X	X
356 mm height	C1CURB71A-1	11F51	X	X	X	X	X
457 mm height	C1CURB72A-1	11F52	X	X	X	X	X
610 mm height	C1CURB73A-1	11F53	X	X	X	X	X
Adjustable Pitch Curb							
356 mm height	C1CURB55AT1	43W27	X	X	X	X	X
Transition Curb							
Matches Emergence® 036-072 Units to existing L Series® Curbs	E1CURB60A-1	20W06	X	X	X	X	X
CEILING DIFFUSERS							
Step-Down - Order one	RTD9-65S	13K60	X	X	X		
	RTD11-95S	13K61				X	X
Flush - Order one	FD9-65S	13K55	X	X	X		
	FD11-95S	13K56				X	X
Transitions (Supply and Return) - Order one	T1TRAN10AN1	17W53	X	X	X		
	T1TRAN20N-1	17W54				X	X

¹ Required when Economizer is factory installed (no exhaust option) with field installed Power Exhaust Fan option.

² Required when Economizer is factory installed with factory installed Power Exhaust Fan option.

³ Lamps operate on 220V single-phase power supply. Step-down transformer must be field supplied for field installation for 380/420V primary to 220V secondary. Alternately, a separate 220V power supply may be used to directly power the UVC ballast(s).

NOTE - Catalog and model numbers shown are for ordering field installed accessories.

OX = Configure To Order (Factory Installed) or Field Installed

O = Configure To Order (Factory Installed)

X = Field Installed

SPECIFICATIONS

General Data		Nominal kW (Tons)	10.6 kW (3 Ton)	14 kW (4 Ton)	17.6 kW (5 Ton)	21 kW (6 Ton)	21 kW (6 Ton)	
		Model Number	LGH036S4T	LGH048S4T	LGH060S4T	LGH072H4B	LGH074H4T	
		Efficiency Type	Standard	Standard	Standard	High	High	
		Blower Type	Two Speed Belt Drive	Two Speed Belt Drive	Two Speed Belt Drive	Single Speed Belt Drive	Two Speed Belt Drive	
Cooling Performance	Gross Cooling Capacity - kW (Btuh)		9.5 (32 400)	12.6 (43 000)	16.4 (56 000)	19.6 (67 000)	18.3 (62 300)	
	Net Cooling Capacity - kW (Btuh)		¹ 9.2 (31 400)	¹ 12.2 (41 500)	¹ 15.9 (54 500)	² 19.2 (65 500)	² 17.5 (59 700)	
	AHRI Rated Air Flow - L/s (cfm)		565 (1200)	755 (1600)	825 (1750)	905 (1920)	991 (2100)	
	Total Unit Power - kW		2.7	3.7	4.5	5.2	4.9	
	SEER (Btuh/Watt)		¹ 15.0	¹ 15.0	¹ 15.5	---	---	
	IEER (Btuh/Watt)		---	---	---	² 13.5	² 16.2	
	¹ EER (Btuh/Watt) at 35°C (95°F)		¹ 11.5	¹ 11.8	¹ 12.0	² 12.0	² 12.2	
	³ EER (Btuh/Watt) at 46°C (115°F)		8.1	8.2	8.3	8.5	8.5	
Refrigerant Charge	Refrigerant Type		R-410A	R-410A	R-410A	R-410A	R-410A	
	Environ™ Coil System		1.95 kg (4 lbs. 5 oz.)	2.83 kg (6 lbs. 4 oz.)	3.63 kg (8 lbs. 0 oz.)	3.40 kg (7 lbs. 8 oz.)	3.23 kg (7 lbs. 2 oz.)	
	Conventional Fin/Tube Coil		3.86 kg (8 lbs. 8 oz.)	5.05 kg (11 lbs. 2 oz.)	6.35 kg (14 lbs. 0 oz.)	6.24 kg (13 lbs. 12 oz.)	6.21 kg (13 lbs. 11 oz.)	
	Environ™ Coil System With Humiditrol®		2.32 kg (5 lbs. 2 oz.)	2.95 kg (6 lbs. 8 oz.)	3.63 kg (8 lbs. 0 oz.)	4.08 kg (9 lbs. 0 oz.)	4.05 kg (8 lbs. 15 oz.)	
	Conventional Fin/Tube With Humiditrol® Option		4.17 kg (9 lbs. 3 oz.)	5.56 kg (12 lbs. 4 oz.)	7.26 kg (16 lbs. 0 oz.)	6.89 kg (15 lbs. 3 oz.)	7.12 kg (15 lbs. 11 oz.)	
	Gas Heating Options Available - See page 21		Standard (1 stage) or Medium (1 or 2 stage)	Standard (1 stage), Medium (1 or 2 Stage) or High (1 or 2 Stage)	Standard (1 stage), Medium (1 or 2 Stage) or High (1 or 2 Stage)	Standard (1 stage), Medium (1 or 2 Stage) or High (1 or 2 Stage)	Standard (1 stage), Medium (1 or 2 stage) or High (1 or 2 stage)	
Compressor Type (number)		Scroll (1)	Scroll (1)	Scroll (1)	Scroll (1)	Scroll (1)		
Outdoor Coil Environ™/ (Fin/Tube)	Net face area (total) - m ² (sq. ft.)		1.09 (11.70)/ 1.45 (15.60)	1.09 (11.70)/ 1.45 (15.60)	1.65 (17.80)/ 1.79 (19.30)	1.65 (17.80)/ 1.79 (19.30)	1.65 (17.80)/ 1.79 (19.30)	
	Tube diameter - mm (in.)		18 (0.71)/ 9.5 (3/8)	18 (0.71)/ 9.5 (3/8)	18 (0.71)/ 9.5 (3/8)	18 (0.71)/ 9.5 (3/8)	---	
	Number of rows		1 (1.5)	1 (2)	1 (2)	1 (2)	1 (2)	
	Fins per m (Fins per inch)		788 (20)	788 (20)	788 (20)	788 (20)	788 (20)	
Outdoor Coil Fans	Motor - (No.) W (horsepower)		(1) 124 (1/6)	(1) 185 (1/4)	(1) 250 1/3	(1) 250 (1/3)	(1) 249 (1/3)	
	Motor rev/min		688	688	896	896	900	
	Total Motor Input - watts		128	176	313	313	284	
	Diameter - (No.) mm (in.)		(1) 610 (24)	(1) 610 (24)	(1) 610 (24)	(1) 610 (24)	(1) 610 (24)	
	Number of blades		3	3	3	3	3	
	Total air volume - L/s (cfm)		1180 (2500)	1295 (2750)	1885 (4000)	1885 (4000)	1848 (3900)	
Indoor Coils	Net face area (total) - m ² (sq. ft.)		0.72 (7.78)	0.72 (7.78)	0.90 (9.72)	0.90 (9.72)	0.90 (9.72)	
	Tube diameter - mm (in.)		9.5 (3/8)	9.5 (3/8)	9.5 (3/8)	9.5 (3/8)	9.5 (3/8)	
	Number of rows		3	4	4	4	4	
	Fins per m (Fins per inch)		551 (14)	551 (14)	551 (14)	551 (14)	551 (14)	
Drain connection (Number) and size - in.		(1) 1 NPT	(1) 1 NPT	(1) 1 NPT	(1) 1 NPT	(1) 1 NPT		
Expansion device type		Balance port thermal expansion valve, removable head						
Indoor Blower and Drive Selection	Nominal Motor kW (hp)		0.47 (0.63)	0.47 (0.63)	0.62 (0.83)	1.5 (2)	0.75 (1) 1.5 (2)	
	Maximum usable motor kW (hp)		0.54 (0.72)	0.54 (0.72)	0.71 (0.95)	1.7 (2.3)	0.88 (1.15) 1.72 (2.3)	
	Kit # (rev/min range)		A01 (low 374-561) (high 546-842)	A02 (low 414 621) (high 621-931)	A03 (low 463-694) (high 694-1042)	AA02 (527-729) AA03 (665-921) AA04 (768-1023)	--- --- AA03 (665-921) AA04 (768-1023)	
	Nominal Motor kW (hp)		0.62 (0.83)	1.24 (1.66)	1.24 (1.66)	---	---	
	Maximum usable motor kW (hp)		0.71 (0.95)	1.42 (1.91)	1.42 (1.91)	---	---	
	Kit # (rev/min range)		A05 (low 498-748) (high 748-1122)	A06 (low 595-794) (high 893-1191)	A07 (low 673-860) (high 1010 -1290)	---	---	
	Blower wheel nominal diameter x width - mm (in.)		(1) 254 x 254 10 x 10)	(1) 254 x 254 (10 x 10)	(1) 254 x 254 (10 x 10)	(1) 381 x 229 (15 x 9)	(1) 381 x 229 (15 x 9)	
	Filters	Type of filter		disposable				
		Number and size - mm (in.)		(4) 406 x 508 x 51 (16 x 20 x 2)	(4) 508 x 508 x 51 (20 x 20 x 2)			
	Electrical characteristics			380/420V-50 Hz-3 phase with neutral				

NOTE - Net capacity includes evaporator blower motor heat deduction. Gross capacity does not include evaporator blower motor heat deduction.

^{1,2} Tested at conditions included in AHRI Standard ¹ 210/240 or ² 340/360; 35°C (95°F) outdoor air temperature and 27°C (80°F) dry bulb/19°C (67°F) wet bulb entering evaporator air; minimum external duct static pressure while operating at rated voltage and air volumes.

³ Rated at 46°C (115°F) outdoor air temperature and 27°C (80°F) db/19°C (67°F) wb entering evaporator air (T3 Conditions).

⁴ Using total air volume and system static pressure requirements determine from blower performance tables rev/min and motor output required. Maximum usable output of motors furnished are shown. If motors of comparable output are used, be sure to keep within the service factor limitations outlined on the motor nameplate.

SPECIFICATIONS - GAS HEAT

Model No.	036, 048, 060	072, 074	036, 048, 060	072, 074	036, 048, 060	072, 074	036, 048, 060	072, 074	048, 060	072, 074	048, 060	072, 074	
Heat Input Type	Standard (1 Stage)		Standard (2 Stage)		Medium (1 Stage)		Medium (2 Stage)		High (1 Stage)		High (2 Stage)		
Input kW (Btuh)	1st Stage	16.7 (57 000)	13.8 (47 000)		27.8 (95 000)		20.8 (71 000)		38.7 (132 000)		29.0 (99 000)		
	2nd Stage	---	18.1 (62 000)		---		27.8 (95 000)		---		38.7 (132 000)		
Output kW (Btuh)	1st Stage	13.5 (46 000)	11.1 (38 000)		22.3 (76 000)		16.7 (57 000)		31.1 (106 000)		23.2 (79 000)		
	2nd Stage	---	14.6 (50 000)		---		22.3 (76 000)		---		31.1 (106 000)		
Temperature Rise Range °C (°F)	1st Stage	6-22 (10-40)	3-19 (5-35)	3-19 (5-35)	3-19 (5-35)	14-36 (25-65)	6-22 (10-40)	11-28 (20-50)	3-19 (5-35)	22-39 (40-70)	11-28 (20-50)	14-31 (25-55)	6-22 (10-40)
	2nd Stage	---	---	6-22 (10-40)	6-22 (10-40)	---	---	14-36 (25-65)	6-22 (10-40)	---	---	22-39 (40-70)	11-28 (20-50)
¹ Thermal Efficiency	80%	80%	80%	80%	80%	80%	80%	80%	80%	80%	80%	80%	
Gas Supply Connections	1/2 in. NPT												
Recommended Gas Supply Pressure - Natural/ LPG	1.7 kPa (7.0 in. w.c.) / 2.7 kPa (11.0 in. w.c.)												

¹ Thermal Efficiency at full input.

HIGH ALTITUDE DERATE

NOTE - Units may be installed at altitudes up to 610 m (2000 ft) above sea level without any modifications. At altitudes above 610 m (2000 ft.), units must be derated to match information in the table shown. At altitudes above 1372 m (4500 ft.), unit must be derated 2% for each 305 m (1000 ft.) above sea level.

NOTE - This is the only permissible derate for these units.

Heat Input Type	Altitude Feet		Gas Manifold Pressure				Input Rate	
			kPa		in. w.g.			
	Meters	Feet	Natural Gas	LPG/ Propane	Natural Gas	LPG/ Propane	kW	Btuh
Standard (1 stage)	610 - 1372	2001 - 4500	0.58	1.73	2.3	6.9	15.5	53 000
Medium (1 stage)	610 - 1372	2001 - 4500	0.58	1.73	2.3	6.9	25.8	88 000
Medium (2 stage)	610 - 1372	2001 - 4500	0.58 / 0.33	1.73 / 0.98	2.3 / 1.3	6.9 / 3.9	25.8 / 19.3	88 000 / 66 000
High (1 stage)	610 - 1372	2001 - 4500	0.58	1.73	2.3	6.9	35.8	122 000
High (2 stage)	610 - 1372	2001 - 4500	0.58 / 0.33	1.73 / 0.98	2.3 / 1.3	6.9 / 3.9	35.8 / 27.0	122 000 / 92 000

COOLING RATINGS

NOTE - For Temperatures and Capacities not shown in tables, see bulletin - Cooling Unit Rating Table Correction Factor Data in Miscellaneous Engineering Data section.

10.6 kW - LGH036S4 (1ST STAGE)

Entering Wet Bulb Temperature	Total Air Volume	Outdoor Air Temperature Entering Outdoor Coil																							
		18°C						24°C						29°C						35°C					
		Total Cool Cap.	Comp. Motor Input	Sensible To Total Ratio (S/T)			Total Cool Cap.	Comp. Motor Input	Sensible To Total Ratio (S/T)			Total Cool Cap.	Comp. Motor Input	Sensible To Total Ratio (S/T)			Total Cool Cap.	Comp. Motor Input	Sensible To Total Ratio (S/T)						
				Dry Bulb					Dry Bulb					Dry Bulb					Dry Bulb						
L/s	kW	kW	24°C	27°C	29°C	kW	kW	24°C	27°C	29°C	kW	kW	24°C	27°C	29°C	kBtu/h	kW	24°C	27°C	29°C					
17°C	300	7.1	.93	0.71	0.85	1.00	6.7	1.09	0.72	0.88	1.00	6.2	1.26	0.73	0.91	1.00	5.8	1.47	0.75	0.94	1.00				
	380	7.5	.93	0.76	0.94	1.00	7.1	1.08	0.77	0.97	1.00	6.6	1.25	0.79	1.00	1.00	6.2	1.45	0.82	1.00	1.00				
	455	7.9	.92	0.81	1.00	1.00	7.4	1.07	0.84	1.00	1.00	7.0	1.24	0.87	1.00	1.00	6.6	1.44	0.90	1.00	1.00				
19°C	300	7.5	.93	0.56	0.68	0.81	7.1	1.08	0.57	0.70	0.83	6.7	1.25	0.57	0.71	0.86	6.2	1.45	0.57	0.73	0.89				
	380	7.9	.92	0.59	0.74	0.90	7.5	1.07	0.59	0.75	0.93	7.0	1.24	0.60	0.77	0.96	6.5	1.44	0.61	0.79	1.00				
	455	8.3	.92	0.62	0.79	0.98	7.8	1.07	0.62	0.81	1.00	7.3	1.24	0.65	0.84	1.00	6.8	1.44	0.66	0.87	1.00				
22°C	300	8.0	.92	0.42	0.54	0.66	7.6	1.07	0.42	0.55	0.68	7.1	1.24	0.42	0.56	0.69	6.6	1.44	0.42	0.56	0.70				
	380	8.4	.92	0.44	0.58	0.72	7.9	1.06	0.44	0.59	0.73	7.4	1.24	0.43	0.58	0.75	6.9	1.43	0.43	0.60	0.77				
	455	8.7	.92	0.45	0.61	0.77	8.2	1.06	0.44	0.62	0.79	7.7	1.23	0.45	0.63	0.81	7.2	1.42	0.46	0.65	0.85				

10.6 kW - LGH036S4 (2ND STAGE)

Entering Wet Bulb Temperature	Total Air Volume	Outdoor Air Temperature Entering Outdoor Coil																							
		26.7°C						35°C						43.3°C						46°C					
		Total Cool Cap.	Comp. Motor Input	Sensible To Total Ratio (S/T)			Total Cool Cap.	Comp. Motor Input	Sensible To Total Ratio (S/T)			Total Cool Cap.	Comp. Motor Input	Sensible To Total Ratio (S/T)			Total Cool Cap.	Comp. Motor Input	Sensible To Total Ratio (S/T)						
				Dry Bulb					Dry Bulb					Dry Bulb					Dry Bulb						
L/s	kW	kW	24°C	27°C	29°C	kW	kW	24°C	27°C	29°C	kW	kW	24°C	27°C	29°C	kW	kW	24°C	27°C	29°C					
17.2°C	455	9.2	1.80	0.74	0.91	1.00	8.4	2.13	0.76	0.95	1.00	7.5	2.54	0.79	1.00	1.00	7.3	2.70	0.82	1.00	1.00				
	565	9.6	1.81	0.80	1.00	1.00	8.9	2.15	0.83	1.00	1.00	8.1	2.56	0.88	1.00	1.00	7.8	2.71	0.92	1.00	1.00				
	680	10.1	1.83	0.86	1.00	1.00	9.3	2.16	0.92	1.00	1.00	8.4	2.57	0.97	1.00	1.00	8.2	2.72	0.99	1.00	1.00				
19.4°C	455	9.7	1.82	0.58	0.72	0.87	8.9	2.15	0.59	0.74	0.91	8.0	2.56	0.60	0.77	0.96	7.7	2.71	0.61	0.81	0.98				
	565	10.1	1.83	0.61	0.78	0.96	9.3	2.16	0.63	0.81	1.00	8.3	2.57	0.65	0.86	1.00	8.0	2.71	0.67	0.89	1.00				
	680	10.5	1.84	0.65	0.84	1.00	9.6	2.17	0.67	0.89	1.00	8.6	2.57	0.70	0.95	1.00	8.2	2.72	0.72	0.97	1.00				
21.7°C	455	10.3	1.84	0.43	0.57	0.70	9.4	2.16	0.42	0.58	0.72	8.5	2.57	0.43	0.59	0.75	8.1	2.72	0.43	0.61	0.78				
	565	10.7	1.85	0.45	0.61	0.76	9.8	2.17	0.44	0.62	0.79	8.8	2.57	0.45	0.64	0.83	8.5	2.72	0.46	0.67	0.87				
	680	11.0	1.86	0.46	0.64	0.83	10.1	2.18	0.47	0.66	0.87	9.1	2.58	0.47	0.69	0.93	8.7	2.73	0.48	0.72	0.96				

Entering Wet Bulb Temperature	Total Air Volume	Outdoor Air Temperature Entering Outdoor Coil																	
		48°C						50°C						51.7°C					
		Total Cool Cap.	Comp. Motor Input	Sensible To Total Ratio (S/T)			Total Cool Cap.	Comp. Motor Input	Sensible To Total Ratio (S/T)			Total Cool Cap.	Comp. Motor Input	Sensible To Total Ratio (S/T)					
				Dry Bulb					Dry Bulb					Dry Bulb					
L/s	kW	kW	24°C	27°C	29°C	kW	kW	24°C	27°C	29°C	kW	kW	24°C	27°C	29°C				
17.2°C	455	7.1	2.82	0.84	1.00	1.00	6.9	2.95	0.85	1.00	1.00	6.7	3.07	0.84	1.00	1.00			
	565	7.6	2.83	0.93	1.00	1.00	7.4	2.96	0.95	1.00	1.00	7.2	3.08	0.96	1.00	1.00			
	680	8.0	2.84	1.00	1.00	1.00	7.7	2.97	1.00	1.00	1.00	7.5	3.09	1.00	1.00	1.00			
19.4°C	455	7.4	2.82	0.62	0.81	1.00	7.2	2.95	0.63	0.83	1.00	7.0	3.07	0.62	0.82	1.00			
	565	7.7	2.83	0.68	0.91	1.00	7.5	2.96	0.69	0.92	1.00	7.2	3.08	0.68	0.93	1.00			
	680	8.0	2.84	0.73	0.99	1.00	7.7	2.96	0.74	1.00	1.00	7.5	3.09	0.73	1.00	1.00			
21.7°C	455	7.9	2.84	0.43	0.61	0.79	7.6	2.97	0.43	0.62	0.80	7.4	3.08	0.42	0.62	0.79			
	565	8.2	2.84	0.46	0.68	0.88	7.9	2.97	0.46	0.69	0.90	7.7	3.09	0.46	0.68	0.91			
	680	8.4	2.85	0.48	0.73	0.97	8.1	2.97	0.48	0.74	0.99	7.9	3.09	0.48	0.73	1.00			

COOLING RATINGS

NOTE - For Temperatures and Capacities not shown in tables, see bulletin - Cooling Unit Rating Table Correction Factor Data in Miscellaneous Engineering Data section.

14 kW - LGH048S4 (1ST STAGE)

Entering Wet Bulb Temperature	Total Air Volume	Outdoor Air Temperature Entering Outdoor Coil																			
		18°C					24°C					29°C					35°C				
		Total Cool Cap.	Comp. Motor Input	Sensible To Total Ratio (S/T)			Total Cool Cap.	Comp. Motor Input	Sensible To Total Ratio (S/T)			Total Cool Cap.	Comp. Motor Input	Sensible To Total Ratio (S/T)			Total Cool Cap.	Comp. Motor Input	Sensible To Total Ratio (S/T)		
				Dry Bulb					Dry Bulb					Dry Bulb					Dry Bulb		
L/s	kW	kW	24°C	27°C	29°C	kW	kW	24°C	27°C	29°C	kW	kW	24°C	27°C	29°C	kBtuh	kW	24°C	27°C	29°C	
17°C	400	9.7	1.13	0.69	0.84	1.00	9.1	1.36	0.70	0.86	1.00	8.6	1.60	0.71	0.89	1.00	7.9	1.87	0.72	0.91	1.00
	505	10.2	1.12	0.75	0.94	1.00	9.7	1.34	0.76	0.97	1.00	9.1	1.59	0.77	1.00	1.00	8.5	1.86	0.79	1.00	1.00
	605	10.8	1.11	0.81	1.00	1.00	10.3	1.33	0.83	1.00	1.00	9.7	1.57	0.86	1.00	1.00	9.1	1.85	0.89	1.00	1.00
19°C	400	10.4	1.12	0.55	0.68	0.80	9.8	1.34	0.55	0.68	0.82	9.2	1.58	0.55	0.69	0.84	8.6	1.86	0.54	0.70	0.87
	505	11.0	1.11	0.57	0.72	0.89	10.4	1.33	0.56	0.74	0.92	9.7	1.57	0.59	0.75	0.95	9.1	1.85	0.60	0.77	0.99
	605	11.4	1.10	0.61	0.78	0.98	10.8	1.32	0.62	0.79	1.00	10.1	1.56	0.62	0.83	1.00	9.4	1.84	0.64	0.85	1.00
22°C	400	11.1	1.10	0.42	0.53	0.64	10.6	1.32	0.41	0.54	0.65	9.9	1.57	0.40	0.54	0.66	9.2	1.84	0.40	0.54	0.68
	505	11.7	1.09	0.42	0.56	0.70	11.0	1.31	0.39	0.55	0.71	10.4	1.56	0.43	0.57	0.73	9.7	1.83	0.40	0.58	0.75
	605	12.2	1.08	0.43	0.60	0.76	11.5	1.30	0.42	0.61	0.77	10.8	1.55	0.44	0.62	0.79	10.1	1.82	0.43	0.63	0.82

14 kW - LGH048S4 (2ND STAGE)

Entering Wet Bulb Temperature	Total Air Volume	Outdoor Air Temperature Entering Outdoor Coil																			
		26.7°C					35°C					43.3°C					46°C				
		Total Cool Cap.	Comp. Motor Input	Sensible To Total Ratio (S/T)			Total Cool Cap.	Comp. Motor Input	Sensible To Total Ratio (S/T)			Total Cool Cap.	Comp. Motor Input	Sensible To Total Ratio (S/T)			Total Cool Cap.	Comp. Motor Input	Sensible To Total Ratio (S/T)		
				Dry Bulb					Dry Bulb					Dry Bulb					Dry Bulb		
L/s	kW	kW	24°C	27°C	29°C	kW	kW	24°C	27°C	29°C	kW	kW	24°C	27°C	29°C	kW	kW	24°C	27°C	29°C	
17.2°C	605	12.4	2.27	0.73	0.90	1.00	11.3	2.69	0.75	0.95	1.00	10.1	3.20	0.78	1.00	1.00	9.8	3.39	0.83	1.00	1.00
	755	13.1	2.29	0.79	1.00	1.00	12.1	2.71	0.82	1.00	1.00	10.9	3.24	0.88	1.00	1.00	10.5	3.43	0.92	1.00	1.00
	905	13.9	2.31	0.87	1.00	1.00	12.7	2.74	0.92	1.00	1.00	11.6	3.26	0.98	1.00	1.00	11.2	3.46	1.00	1.00	1.00
19.4°C	605	13.3	2.29	0.57	0.71	0.86	12.1	2.71	0.56	0.72	0.90	10.9	3.23	0.59	0.76	0.96	10.4	3.42	0.60	0.80	0.99
	755	13.9	2.31	0.61	0.77	0.97	12.7	2.74	0.61	0.80	1.00	11.3	3.25	0.63	0.85	1.00	10.8	3.44	0.66	0.89	1.00
	905	14.3	2.33	0.64	0.84	1.00	13.1	2.75	0.66	0.89	1.00	11.7	3.27	0.69	0.96	1.00	11.2	3.45	0.72	0.98	1.00
21.7°C	605	14.2	2.32	0.42	0.56	0.68	12.9	2.74	0.41	0.56	0.70	11.6	3.26	0.41	0.57	0.73	11.2	3.46	0.42	0.60	0.78
	755	14.8	2.34	0.44	0.59	0.75	13.5	2.76	0.43	0.61	0.77	12.1	3.28	0.43	0.62	0.82	11.6	3.47	0.44	0.65	0.87
	905	15.2	2.35	0.45	0.64	0.81	13.9	2.77	0.45	0.65	0.86	12.5	3.30	0.47	0.68	0.93	12.0	3.49	0.48	0.72	0.96

Entering Wet Bulb Temperature	Total Air Volume	Outdoor Air Temperature Entering Outdoor Coil														
		48°C					50°C					51.7°C				
		Total Cool Cap.	Comp. Motor Input	Sensible To Total Ratio (S/T)			Total Cool Cap.	Comp. Motor Input	Sensible To Total Ratio (S/T)			Total Cool Cap.	Comp. Motor Input	Sensible To Total Ratio (S/T)		
				Dry Bulb					Dry Bulb					Dry Bulb		
L/s	kW	kW	24°C	27°C	29°C	kW	kW	24°C	27°C	29°C	kW	kW	24°C	27°C	29°C	
17.2°C	605	9.5	3.56	0.84	1.00	1.00	9.2	3.72	0.85	1.00	1.00	9.0	3.88	0.84	1.00	1.00
	755	10.2	3.58	0.94	1.00	1.00	10.0	3.75	0.95	1.00	1.00	9.6	3.91	0.96	1.00	1.00
	905	10.8	3.61	1.00	1.00	1.00	10.5	3.78	1.00	1.00	1.00	10.2	3.93	1.00	1.00	1.00
19.4°C	605	10.1	3.58	0.61	0.81	1.00	9.7	3.74	0.61	0.82	1.00	9.4	3.90	0.60	0.80	1.00
	755	10.5	3.60	0.67	0.91	1.00	10.1	3.76	0.68	0.93	1.00	9.8	3.92	0.66	0.93	1.00
	905	10.8	3.61	0.72	0.99	1.00	10.4	3.77	0.75	1.00	1.00	10.2	3.93	0.72	1.00	1.00
21.7°C	605	10.8	3.60	0.42	0.59	0.78	10.4	3.77	0.41	0.60	0.80	10.1	3.93	0.40	0.60	0.78
	755	11.3	3.63	0.45	0.66	0.89	10.8	3.79	0.45	0.67	0.90	10.5	3.95	0.44	0.66	0.90
	905	11.6	3.64	0.48	0.72	0.97	11.2	3.81	0.50	0.73	0.99	10.8	3.97	0.45	0.72	1.00

COOLING RATINGS

NOTE - For Temperatures and Capacities not shown in tables, see bulletin - Cooling Unit Rating Table Correction Factor Data in Miscellaneous Engineering Data section.

17.6 kW - LGH060S4 (1ST STAGE)

Entering Wet Bulb Temperature	Total Air Volume	Outdoor Air Temperature Entering Outdoor Coil																			
		18°C					24°C					29°C					35°C				
		Total Cool Cap.	Comp. Motor Input	Sensible To Total Ratio (S/T)			Total Cool Cap.	Comp. Motor Input	Sensible To Total Ratio (S/T)			Total Cool Cap.	Comp. Motor Input	Sensible To Total Ratio (S/T)			Total Cool Cap.	Comp. Motor Input	Sensible To Total Ratio (S/T)		
				Dry Bulb					Dry Bulb					Dry Bulb					Dry Bulb		
L/s	kW	kW	24°C	27°C	29°C	kW	kW	24°C	27°C	29°C	kW	kW	24°C	27°C	29°C	kBtuh	kW	24°C	27°C	29°C	
17°C	505	12.0	1.33	0.72	0.86	1.00	11.3	1.60	0.72	0.88	1.00	10.6	1.89	0.73	0.90	1.00	9.8	2.21	0.73	0.92	1.00
	630	12.7	1.31	0.77	0.93	1.00	12.0	1.58	0.77	0.96	1.00	11.3	1.88	0.78	0.99	1.00	10.6	2.19	0.82	1.00	1.00
	755	13.3	1.29	0.82	1.00	1.00	12.7	1.56	0.84	1.00	1.00	12.0	1.86	0.87	1.00	1.00	11.3	2.18	0.90	1.00	1.00
19°C	505	12.9	1.30	0.56	0.69	0.82	12.2	1.58	0.57	0.70	0.84	11.5	1.87	0.57	0.71	0.86	10.7	2.19	0.56	0.71	0.87
	630	13.6	1.28	0.59	0.74	0.89	12.9	1.56	0.60	0.76	0.92	12.1	1.85	0.59	0.76	0.95	11.2	2.17	0.60	0.78	0.99
22°C	505	13.8	1.27	0.43	0.55	0.67	13.1	1.55	0.43	0.55	0.67	12.3	1.85	0.42	0.55	0.69	11.4	2.17	0.40	0.55	0.69
	630	14.5	1.25	0.46	0.58	0.71	13.8	1.53	0.43	0.59	0.73	12.9	1.83	0.43	0.58	0.74	12.0	2.15	0.42	0.59	0.75
	755	15.0	1.23	0.47	0.61	0.77	14.2	1.51	0.48	0.61	0.79	13.4	1.82	0.46	0.63	0.82	12.4	2.14	0.45	0.64	0.83

17.6 kW - LGH060S4 (2ND STAGE)

Entering Wet Bulb Temperature	Total Air Volume	Outdoor Air Temperature Entering Outdoor Coil																			
		26.7°C					35°C					43.3°C					46°C				
		Total Cool Cap.	Comp. Motor Input	Sensible To Total Ratio (S/T)			Total Cool Cap.	Comp. Motor Input	Sensible To Total Ratio (S/T)			Total Cool Cap.	Comp. Motor Input	Sensible To Total Ratio (S/T)			Total Cool Cap.	Comp. Motor Input	Sensible To Total Ratio (S/T)		
				Dry Bulb					Dry Bulb					Dry Bulb					Dry Bulb		
L/s	kW	kW	24°C	27°C	29°C	kW	kW	24°C	27°C	29°C	kW	kW	24°C	27°C	29°C	kW	kW	24°C	27°C	29°C	
17.2°C	755	15.6	2.67	0.75	0.91	1.00	14.2	3.17	0.76	0.95	1.00	12.7	3.78	0.79	0.99	1.00	12.3	4.00	0.82	1.00	1.00
	945	16.4	2.69	0.80	1.00	1.00	15.2	3.20	0.83	1.00	1.00	13.8	3.82	0.88	1.00	1.00	13.3	4.04	0.91	1.00	1.00
	1135	17.4	2.72	0.88	1.00	1.00	16.0	3.23	0.92	1.00	1.00	14.6	3.85	0.97	1.00	1.00	14.1	4.07	0.99	1.00	1.00
19.4°C	755	16.7	2.70	0.58	0.72	0.87	15.2	3.20	0.58	0.74	0.91	13.7	3.81	0.58	0.76	0.95	13.2	4.04	0.59	0.79	0.97
	945	17.5	2.73	0.61	0.78	0.96	16.0	3.23	0.63	0.81	1.00	14.3	3.84	0.64	0.86	1.00	13.8	4.07	0.66	0.88	1.00
21.7°C	755	17.8	2.74	0.43	0.57	0.70	16.4	3.24	0.42	0.57	0.72	14.7	3.85	0.41	0.58	0.74	14.2	4.07	0.42	0.59	0.76
	945	18.6	2.76	0.44	0.60	0.76	17.1	3.27	0.45	0.62	0.79	15.4	3.88	0.44	0.64	0.83	14.8	4.10	0.45	0.65	0.86
	1135	19.3	2.78	0.46	0.65	0.82	17.6	3.29	0.46	0.66	0.87	15.9	3.91	0.46	0.69	0.92	15.3	4.13	0.47	0.71	0.94

Entering Wet Bulb Temperature	Total Air Volume	Outdoor Air Temperature Entering Outdoor Coil														
		48°C					50°C					51.7°C				
		Total Cool Cap.	Comp. Motor Input	Sensible To Total Ratio (S/T)			Total Cool Cap.	Comp. Motor Input	Sensible To Total Ratio (S/T)			Total Cool Cap.	Comp. Motor Input	Sensible To Total Ratio (S/T)		
				Dry Bulb					Dry Bulb					Dry Bulb		
L/s	kW	kW	24°C	27°C	29°C	kW	kW	24°C	27°C	29°C	kW	kW	24°C	27°C	29°C	
17.2°C	755	11.9	4.18	0.83	1.00	1.00	11.6	4.38	0.84	1.00	1.00	11.3	4.56	0.84	1.00	1.00
	945	12.9	4.22	0.92	1.00	1.00	12.5	4.42	0.94	1.00	1.00	12.2	4.59	0.95	1.00	1.00
	1135	13.7	4.26	1.00	1.00	1.00	13.3	4.45	1.00	1.00	1.00	12.9	4.63	1.00	1.00	1.00
19.4°C	755	12.8	4.22	0.61	0.80	0.98	12.3	4.41	0.61	0.81	1.00	11.9	4.58	0.61	0.81	1.00
	945	13.4	4.24	0.67	0.90	1.00	12.9	4.43	0.68	0.91	1.00	12.5	4.61	0.67	0.92	1.00
21.7°C	755	13.7	4.25	0.42	0.60	0.77	13.3	4.45	0.41	0.60	0.78	12.9	4.62	0.42	0.60	0.78
	945	14.4	4.29	0.45	0.66	0.87	13.9	4.48	0.45	0.67	0.88	13.5	4.66	0.44	0.67	0.89
	1135	14.8	4.31	0.48	0.72	0.96	14.3	4.50	0.48	0.73	0.97	13.8	4.67	0.48	0.73	0.99

COOLING RATINGS

NOTE - For Temperatures and Capacities not shown in tables, see bulletin - Cooling Unit Rating Table Correction Factor Data in Miscellaneous Engineering Data section.

21 kW - LGH072H4 (FULL LOAD)

Entering Wet Bulb Temperature	Total Air Volume	Outdoor Air Temperature Entering Outdoor Coil																			
		26.7°C						35°C					43.3°C					46°C			
		Total Cool Cap.	Comp. Motor Input	Sensible To Total Ratio (S/T)			Total Cool Cap.	Comp. Motor Input	Sensible To Total Ratio (S/T)			Total Cool Cap.	Comp. Motor Input	Sensible To Total Ratio (S/T)			Total Cool Cap.	Comp. Motor Input	Sensible To Total Ratio (S/T)		
				Dry Bulb					Dry Bulb					Dry Bulb					Dry Bulb		
L/s	kW	kW	24°C	27°C	29°C	kW	kW	24°C	27°C	29°C	kW	kW	24°C	27°C	29°C	kW	kW	24°C	27°C	29°C	
17.2°C	905	19.1	3.55	0.72	0.90	1.00	17.5	4.15	0.74	0.95	1.00	15.6	4.86	0.77	1.00	1.00	15.1	5.11	0.83	1.00	1.00
	1135	20.1	3.56	0.78	1.00	1.00	18.6	4.16	0.81	1.00	1.00	16.9	4.88	0.88	1.00	1.00	16.3	5.13	0.92	1.00	1.00
	1360	21.2	3.58	0.86	1.00	1.00	19.6	4.17	0.91	1.00	1.00	17.9	4.89	0.98	1.00	1.00	17.2	5.15	1.00	1.00	1.00
19.4°C	905	20.4	3.57	0.56	0.70	0.86	18.7	4.16	0.57	0.72	0.90	16.8	4.87	0.57	0.74	0.95	16.1	5.13	0.61	0.80	0.98
	1135	21.3	3.58	0.59	0.76	0.97	19.5	4.17	0.60	0.79	1.00	17.5	4.89	0.62	0.84	1.00	16.9	5.14	0.67	0.89	1.00
	1360	22.0	3.58	0.63	0.83	1.00	20.2	4.18	0.65	0.88	1.00	18.1	4.89	0.68	0.95	1.00	17.4	5.15	0.72	0.98	1.00
21.7°C	905	21.7	3.58	0.41	0.55	0.68	20.0	4.17	0.41	0.56	0.70	17.9	4.89	0.41	0.57	0.72	17.2	5.15	0.41	0.59	0.77
	1135	22.7	3.59	0.43	0.58	0.74	20.8	4.19	0.43	0.60	0.77	18.7	4.90	0.43	0.62	0.80	18.0	5.16	0.44	0.65	0.86
	1360	23.4	3.60	0.44	0.63	0.80	21.4	4.19	0.45	0.64	0.85	19.3	4.91	0.46	0.67	0.92	18.6	5.17	0.47	0.71	0.95

Entering Wet Bulb Temperature	Total Air Volume	Outdoor Air Temperature Entering Outdoor Coil														
		48°C						50°C					51.7°C			
		Total Cool Cap.	Comp. Motor Input	Sensible To Total Ratio (S/T)			Total Cool Cap.	Comp. Motor Input	Sensible To Total Ratio (S/T)			Total Cool Cap.	Comp. Motor Input	Sensible To Total Ratio (S/T)		
				Dry Bulb					Dry Bulb					Dry Bulb		
L/s	kW	kW	24°C	27°C	29°C	kW	kW	24°C	27°C	29°C	kW	kW	24°C	27°C	29°C	
17.2°C	905	14.7	5.32	0.83	1.00	1.00	14.3	5.55	0.85	1.00	1.00	13.9	5.75	0.84	1.00	1.00
	1135	15.8	5.34	0.93	1.00	1.00	15.4	5.56	0.95	1.00	1.00	14.9	5.77	0.96	1.00	1.00
	1360	16.8	5.36	1.00	1.00	1.00	16.2	5.58	1.00	1.00	1.00	15.7	5.79	1.00	1.00	1.00
19.4°C	905	15.6	5.34	0.61	0.81	1.00	15.0	5.55	0.62	0.82	1.00	14.5	5.75	0.60	0.79	1.00
	1135	16.4	5.35	0.67	0.91	1.00	15.8	5.57	0.68	0.93	1.00	15.2	5.78	0.66	0.93	1.00
	1360	16.8	5.36	0.73	0.99	1.00	16.2	5.58	0.74	1.00	1.00	15.7	5.78	0.71	1.00	1.00
21.7°C	905	16.7	5.35	0.42	0.60	0.78	16.2	5.58	0.42	0.61	0.80	15.6	5.78	0.41	0.59	0.77
	1135	17.4	5.37	0.45	0.67	0.88	16.9	5.59	0.45	0.68	0.90	16.3	5.80	0.44	0.65	0.89
	1360	18.0	5.38	0.48	0.72	0.97	17.3	5.60	0.48	0.74	0.99	16.7	5.81	0.47	0.71	0.99

COOLING RATINGS

NOTE - For Temperatures and Capacities not shown in tables, see bulletin - Cooling Unit Rating Table Correction Factor Data in Miscellaneous Engineering Data section.

21 kW - LGH074H4 (1ST STAGE)

Entering Wet Bulb Temperature	Total Air Volume	Outdoor Air Temperature Entering Outdoor Coil																							
		18°C						24°C						29°C						35°C					
		Total Cool Cap.	Comp. Motor Input	Sensible To Total Ratio (S/T)			Total Cool Cap.	Comp. Motor Input	Sensible To Total Ratio (S/T)			Total Cool Cap.	Comp. Motor Input	Sensible To Total Ratio (S/T)			Total Cool Cap.	Comp. Motor Input	Sensible To Total Ratio (S/T)						
				Dry Bulb					Dry Bulb					Dry Bulb					Dry Bulb						
L/s	kW	kW	24°C	27°C	29°C	kW	kW	24°C	27°C	29°C	kW	kW	24°C	27°C	29°C	kBtuh	kW	24°C	27°C	29°C					
17°C	565	13.7	1.85	0.74	0.88	0.97	13.1	2.13	0.75	0.90	0.99	12.5	2.40	0.76	0.92	1.00	11.7	2.77	0.78	0.95	1.00				
	755	14.8	1.84	0.81	0.98	1.00	14.1	2.12	0.82	1.00	1.00	13.5	2.39	0.84	1.00	1.00	12.8	2.76	0.86	1.00	1.00				
	945	16.0	1.82	0.88	1.00	1.00	15.3	2.11	0.90	1.00	1.00	14.6	2.38	0.92	1.00	1.00	13.7	2.75	0.95	1.00	1.00				
19°C	565	14.7	1.84	0.59	0.74	0.82	14.0	2.13	0.60	0.75	0.84	13.3	2.40	0.61	0.76	0.86	12.5	2.77	0.62	0.78	0.88				
	755	15.8	1.83	0.65	0.82	0.92	15.0	2.11	0.66	0.82	0.94	14.3	2.39	0.64	0.84	0.96	13.3	2.76	0.67	0.87	0.99				
	945	16.5	1.82	0.69	0.89	1.00	15.7	2.10	0.71	0.91	1.00	15.0	2.38	0.71	0.93	1.00	14.0	2.75	0.73	0.96	1.00				
22°C	565	16.1	1.82	0.41	0.53	0.62	15.3	2.11	0.42	0.54	0.63	14.6	2.38	0.41	0.55	0.64	13.7	2.75	0.41	0.56	0.65				
	755	17.2	1.81	0.43	0.59	0.69	16.4	2.09	0.43	0.60	0.70	15.6	2.37	0.42	0.60	0.71	14.7	2.74	0.43	0.61	0.73				
	945	18.1	1.79	0.45	0.63	0.74	17.2	2.08	0.45	0.64	0.75	16.4	2.36	0.45	0.64	0.78	15.4	2.73	0.46	0.67	0.80				

21 kW - LGH074H4 (2ND STAGE)

Entering Wet Bulb Temperature	Total Air Volume	Outdoor Air Temperature Entering Outdoor Coil																							
		26.7°C						35°C						43.3°C						46°C					
		Total Cool Cap.	Comp. Motor Input	Sensible To Total Ratio (S/T)			Total Cool Cap.	Comp. Motor Input	Sensible To Total Ratio (S/T)			Total Cool Cap.	Comp. Motor Input	Sensible To Total Ratio (S/T)			Total Cool Cap.	Comp. Motor Input	Sensible To Total Ratio (S/T)						
				Dry Bulb					Dry Bulb					Dry Bulb					Dry Bulb						
L/s	kW	kW	24°C	27°C	29°C	kW	kW	24°C	27°C	29°C	kW	kW	24°C	27°C	29°C	kW	kW	24°C	27°C	29°C					
17.2°C	905	18.0	3.22	0.80	0.97	1.00	16.5	3.85	0.82	1.00	1.00	15.1	4.63	0.86	1.00	1.00	14.7	4.91	0.87	1.00	1.00				
	1135	19.1	3.25	0.87	1.00	1.00	17.8	3.90	0.90	1.00	1.00	16.2	4.66	0.95	1.00	1.00	15.7	4.94	0.97	1.00	1.00				
	1360	20.2	3.28	0.94	1.00	1.00	18.6	3.92	0.98	1.00	1.00	17.1	4.70	1.00	1.00	1.00	16.6	4.98	1.00	1.00	1.00				
19.4°C	905	19.0	3.25	0.64	0.81	0.91	17.5	3.88	0.65	0.83	0.95	15.8	4.65	0.67	0.86	0.99	15.2	4.93	0.68	0.88	1.00				
	1135	19.9	3.27	0.69	0.88	0.99	18.2	3.91	0.70	0.91	1.00	16.5	4.68	0.73	0.97	1.00	15.9	4.95	0.75	0.98	1.00				
	1360	20.5	3.29	0.73	0.95	1.00	18.8	3.93	0.76	0.99	1.00	17.1	4.69	0.79	1.00	1.00	16.5	4.97	0.81	1.00	1.00				
21.7°C	905	20.6	3.30	0.43	0.59	0.68	18.9	3.93	0.43	0.60	0.70	17.1	4.70	0.42	0.61	0.72	16.6	4.98	0.43	0.62	0.74				
	1135	21.5	3.32	0.44	0.62	0.74	19.7	3.96	0.45	0.64	0.77	17.8	4.72	0.45	0.66	0.80	17.2	5.00	0.44	0.68	0.82				
	1360	22.1	3.35	0.46	0.66	0.80	20.3	3.99	0.47	0.69	0.84	18.3	4.75	0.47	0.72	0.88	17.7	5.02	0.47	0.73	0.90				

Entering Wet Bulb Temperature	Total Air Volume	Outdoor Air Temperature Entering Outdoor Coil																	
		48°C						50°C						51.7°C					
		Total Cool Cap.	Comp. Motor Input	Sensible To Total Ratio (S/T)			Total Cool Cap.	Comp. Motor Input	Sensible To Total Ratio (S/T)			Total Cool Cap.	Comp. Motor Input	Sensible To Total Ratio (S/T)					
				Dry Bulb					Dry Bulb					Dry Bulb					
L/s	kW	kW	24°C	27°C	29°C	kW	kW	24°C	27°C	29°C	kW	kW	24°C	27°C	29°C				
17.2°C	905	14.3	5.14	0.88	1.00	1.00	14.0	5.37	0.89	1.00	1.00	13.6	5.57	0.91	1.00	1.00			
	1135	15.3	5.16	0.98	1.00	1.00	14.9	5.40	0.99	1.00	1.00	14.5	5.60	1.00	1.00	1.00			
	1360	16.1	5.20	1.00	1.00	1.00	15.7	5.43	1.00	1.00	1.00	15.2	5.62	1.00	1.00	1.00			
19.4°C	905	14.8	5.15	0.68	0.90	1.00	14.3	5.37	0.69	0.91	1.00	13.9	5.57	0.69	0.92	1.00			
	1135	15.4	5.17	0.75	0.99	1.00	14.9	5.40	0.76	1.00	1.00	14.6	5.60	0.77	1.00	1.00			
	1360	16.0	5.19	0.82	1.00	1.00	15.6	5.42	0.82	1.00	1.00	15.3	5.63	0.83	1.00	1.00			
21.7°C	905	16.1	5.19	0.43	0.63	0.75	15.6	5.42	0.43	0.63	0.76	15.2	5.62	0.42	0.63	0.76			
	1135	16.7	5.22	0.45	0.68	0.83	16.2	5.45	0.45	0.69	0.84	15.8	5.65	0.46	0.70	0.86			
	1360	17.2	5.24	0.48	0.74	0.91	16.7	5.47	0.48	0.75	0.93	16.1	5.66	0.48	0.76	0.94			

HUMIDITROL® DEHUMIDIFICATION SYSTEM RATINGS

10.6 kW - LGH036S4 with HUMIDITROL OPERATING

Entering Wet Bulb Temperature	Total Air Volume	Outdoor Air Temperature Entering Outdoor Coil																							
		18°C						24°C						29°C						35°C					
		Total Cool Cap.	Comp. Motor Input	Sensible To Total Ratio (S/T)			Total Cool Cap.	Comp. Motor Input	Sensible To Total Ratio (S/T)			Total Cool Cap.	Comp. Motor Input	Sensible To Total Ratio (S/T)			Total Cool Cap.	Comp. Motor Input	Sensible To Total Ratio (S/T)						
				Dry Bulb					Dry Bulb					Dry Bulb					Dry Bulb						
L/s	kW	kW	24°C	27°C	29°C	kW	kW	24°C	27°C	29°C	kW	kW	24°C	27°C	29°C	kBtuh	kW	24°C	27°C	29°C					
17°C	300	5.8	1.34	0.51	0.68	0.83	4.8	1.48	0.43	0.64	0.83	3.8	1.63	0.33	0.58	0.83	2.7	1.81	0.12	0.47	0.82				
	380	6.2	1.36	0.57	0.75	0.93	5.1	1.49	0.51	0.73	0.94	3.9	1.64	0.31	0.70	0.98	2.7	1.81	0.18	0.63	0.86				
	455	6.5	1.37	0.61	0.82	1.00	5.3	1.50	0.57	0.82	1.00	4.0	1.65	0.47	0.81	1.00	2.7	1.81	0.28	0.79	1.00				
19°C	300	6.6	1.36	0.37	0.51	0.65	5.6	1.50	0.28	0.45	0.62	4.5	1.66	0.15	0.36	0.57	3.4	1.83	-0.06	0.22	0.49				
	380	7.0	1.38	0.40	0.57	0.72	5.9	1.51	0.30	0.50	0.71	4.8	1.67	0.17	0.36	0.67	3.5	1.83	-0.06	0.29	0.62				
	455	7.3	1.39	0.42	0.61	0.79	6.1	1.52	0.34	0.57	0.78	4.8	1.67	0.20	0.50	0.78	3.4	1.83	-0.04	0.38	0.75				
22°C	300	7.4	1.38	0.25	0.38	0.51	6.3	1.52	0.16	0.31	0.45	5.2	1.68	0.02	0.21	0.38	4.1	1.85	-0.19	0.05	0.27				
	380	7.9	1.40	0.26	0.41	0.55	6.7	1.53	0.16	0.33	0.51	5.5	1.68	0.02	0.23	0.44	4.2	1.85	-0.22	0.08	0.31				
	455	8.2	1.41	0.27	0.44	0.60	6.9	1.54	0.17	0.37	0.56	5.6	1.69	0.02	0.26	0.51	4.2	1.85	-0.24	0.10	0.42				

14 kW - LGH048S4 with HUMIDITROL OPERATING

Entering Wet Bulb Temperature	Total Air Volume	Outdoor Air Temperature Entering Outdoor Coil																							
		18°C						24°C						29°C						35°C					
		Total Cool Cap.	Comp. Motor Input	Sensible To Total Ratio (S/T)			Total Cool Cap.	Comp. Motor Input	Sensible To Total Ratio (S/T)			Total Cool Cap.	Comp. Motor Input	Sensible To Total Ratio (S/T)			Total Cool Cap.	Comp. Motor Input	Sensible To Total Ratio (S/T)						
				Dry Bulb					Dry Bulb					Dry Bulb					Dry Bulb						
L/s	kW	kW	24°C	27°C	29°C	kW	kW	24°C	27°C	29°C	kW	kW	24°C	27°C	29°C	kBtuh	kW	24°C	27°C	29°C					
17°C	420	7.9	1.67	0.50	0.67	0.83	6.6	1.86	0.43	0.63	0.83	5.2	2.07	0.33	0.58	0.83	3.9	2.29	0.18	0.50	0.84				
	525	8.4	1.69	0.56	0.75	0.94	6.9	1.87	0.43	0.74	0.85	5.5	2.08	0.41	0.70	1.00	3.9	2.29	0.26	0.68	0.93				
	630	8.8	1.70	0.60	0.85	1.00	7.2	1.88	0.57	0.84	0.99	5.6	2.08	0.47	0.84	1.00	4.0	2.30	0.35	0.76	0.81				
19°C	420	9.0	1.70	0.35	0.49	0.64	7.6	1.89	0.27	0.44	0.61	6.3	2.10	0.16	0.35	0.56	4.8	2.33	-0.01	0.25	0.50				
	525	9.5	1.72	0.31	0.54	0.71	8.1	1.91	0.30	0.50	0.70	6.5	2.11	0.19	0.42	0.67	4.9	2.33	0.00	0.32	0.65				
	630	9.9	1.73	0.40	0.60	0.80	8.3	1.92	0.33	0.57	0.80	6.7	2.11	0.21	0.49	0.80	4.9	2.33	0.03	0.40	0.79				
22°C	420	10.1	1.73	0.23	0.35	0.48	8.7	1.93	0.15	0.29	0.43	7.3	2.14	0.04	0.20	0.36	5.9	2.36	-0.14	0.07	0.28				
	525	10.6	1.75	0.24	0.39	0.54	9.3	1.95	0.15	0.27	0.49	7.6	2.14	0.03	0.23	0.43	6.0	2.37	-0.16	0.10	0.36				
	630	11.1	1.77	0.24	0.41	0.58	9.4	1.95	0.15	0.35	0.55	7.7	2.15	0.03	0.26	0.50	6.0	2.37	-0.18	0.13	0.34				

17.6 kW - LGH060S4 with HUMIDITROL OPERATING

Entering Wet Bulb Temperature	Total Air Volume	Outdoor Air Temperature Entering Outdoor Coil																							
		18°C						24°C						29°C						35°C					
		Total Cool Cap.	Comp. Motor Input	Sensible To Total Ratio (S/T)			Total Cool Cap.	Comp. Motor Input	Sensible To Total Ratio (S/T)			Total Cool Cap.	Comp. Motor Input	Sensible To Total Ratio (S/T)			Total Cool Cap.	Comp. Motor Input	Sensible To Total Ratio (S/T)						
				Dry Bulb					Dry Bulb					Dry Bulb					Dry Bulb						
L/s	kW	kW	24°C	27°C	29°C	kW	kW	24°C	27°C	29°C	kW	kW	24°C	27°C	29°C	kBtuh	kW	24°C	27°C	29°C					
17°C	510	9.4	2.28	0.46	0.64	0.82	7.5	2.53	0.37	0.59	0.81	5.7	2.81	0.20	0.50	0.80	3.7	3.11	-0.09	0.33	0.77				
	635	9.9	2.30	0.52	0.73	0.94	7.9	2.55	0.43	0.69	0.96	5.8	2.82	0.28	0.63	0.98	3.7	3.11	-0.03	0.50	1.00				
	765	10.4	2.31	0.57	0.81	1.00	8.1	2.56	0.49	0.80	1.00	5.9	2.82	0.35	0.77	1.00	3.5	3.11	0.05	0.74	1.00				
19°C	510	10.8	2.32	0.31	0.46	0.62	8.9	2.58	0.21	0.38	0.56	7.0	2.85	0.05	0.28	0.50	5.0	3.16	-0.24	0.08	0.38				
	635	11.5	2.34	0.34	0.52	0.69	9.4	2.60	0.25	0.44	0.62	7.3	2.87	0.02	0.34	0.62	5.1	3.17	-0.24	0.15	0.52				
	765	12.0	2.36	0.36	0.56	0.77	9.7	2.61	0.26	0.51	0.75	7.4	2.88	0.08	0.40	0.73	5.0	3.17	-0.25	0.23	0.67				
22°C	510	12.3	2.36	0.20	0.33	0.46	10.4	2.62	0.10	0.24	0.40	8.4	2.90	-0.06	0.13	0.31	6.4	3.22	-0.32	-0.07	0.16				
	635	13.1	2.39	0.21	0.36	0.51	10.8	2.65	0.10	0.28	0.45	8.6	2.92	-0.07	0.16	0.31	6.5	3.23	-0.36	-0.06	0.23				
	765	13.6	2.41	0.21	0.38	0.56	11.3	2.66	0.10	0.30	0.51	8.9	2.93	-0.08	0.18	0.43	6.5	3.23	-0.40	-0.04	0.30				

21 kW - LGH072H4 with HUMIDITROL OPERATING

Entering Wet Bulb Temperature	Total Air Volume	Outdoor Air Temperature Entering Outdoor Coil																							
		18°C						24°C						29°C						35°C					
		Total Cool Cap.	Comp. Motor Input	Sensible To Total Ratio (S/T)			Total Cool Cap.	Comp. Motor Input	Sensible To Total Ratio (S/T)			Total Cool Cap.	Comp. Motor Input	Sensible To Total Ratio (S/T)			Total Cool Cap.	Comp. Motor Input	Sensible To Total Ratio (S/T)						
				Dry Bulb					Dry Bulb					Dry Bulb					Dry Bulb						
L/s	kW	kW	24°C	27°C	29°C	kW	kW	24°C	27°C	29°C	kW	kW	24°C	27°C	29°C	kBtuh	kW	24°C	27°C	29°C					
17°C	905	11.2	2.70	0.61	0.83	1.00	8.9	3.00	0.53	0.82	0.98	6.4	3.31	0.40	0.83	1.00	4.0	3.67	0.09	0.79	1.00				
	1135	11.6	2.72	0.70	0.95	0.92	8.9	3.01	0.64	0.99	1.00	6.4	3.32	0.54	1.00	1.00	3.9	3.67	0.26	1.00	1.00				
	1360	12.1	2.75	0.76	1.00	1.00	9.5	3.04	0.75	1.00	0.88	6.9	3.35	0.69	0.99	1.00	4.1	3.69	0.49	1.00	0.99				
19°C	905	12.7	2.77	0.39	0.60	0.80	10.4	3.07	0.27	0.54	0.79	7.9	3.39	0.08	0.45	0.77	5.5	3.75	-0.28	0.26	0.76				
	1135	13.2	2.79	0.44	0.68	0.91	10.6	3.09	0.33	0.62	0.94	7.9	3.40	0.13	0.57	0.96	5.2	3.74	-0.27	0.43	1.00				
	1360	13.5	2.81	0.48	0.75	1.00	10.7	3.09	0.37	0.73	1.00	7.8	3.40	0.18	0.70	1.00	5.0	3.73	-0.25	0.57	1.00				
22°C	905	14.3	2.84	0.21	0.41	0.59	11.9	3.14	0.08	0.32	0.55	9.4	3.47	-0.12	0.18	0.47	6.9	3.82	-0.49	-0.05	0.34				
	1135	14.7	2.87	0.23	0.46	0.68	12.1	3.16	0.09	0.37	0.64	9.4	3.47	-0.15	0.25	0.59	6.7	3.82	-0.57	-0.02	0.49				
	1360	15.1	2.89	0.24	0.50	0.75	12.3	3.17	0.10	0.42	0.73	9.3	3.48	-0.15	0.29	0.69	6.4	3.81	-0.64	0.05	0.63				

HUMIDITROL® DEHUMIDIFICATION SYSTEM RATINGS

21 kW - LGH074H4 with HUMIDITROL OPERATING

Entering Wet Bulb Temperature	Total Air Volume	Outdoor Air Temperature Entering Outdoor Coil																			
		18°C					24°C					29°C					35°C				
		Total Cool Cap.	Comp. Motor Input	Sensible To Total Ratio (S/T) Dry Bulb			Total Cool Cap.	Comp. Motor Input	Sensible To Total Ratio (S/T) Dry Bulb			Total Cool Cap.	Comp. Motor Input	Sensible To Total Ratio (S/T) Dry Bulb			Total Cool Cap.	Comp. Motor Input	Sensible To Total Ratio (S/T) Dry Bulb		
				24°C	27°C	29°C			24°C	27°C	29°C			24°C	27°C	29°C			24°C	27°C	29°C
L/s	kW	kW	24°C	27°C	29°C	kW	kW	24°C	27°C	29°C	kW	kW	24°C	27°C	29°C	kBtuh	kW	24°C	27°C	29°C	
17°C	565	10.0	2.62	0.46	0.63	0.80	8.0	2.88	0.39	0.58	0.76	6.2	3.20	0.21	0.49	0.76	4.2	3.57	-0.10	0.32	0.73
	755	10.7	2.66	0.53	0.74	0.95	8.8	2.91	0.44	0.65	0.97	6.5	3.21	0.30	0.60	0.99	4.1	3.57	-0.02	0.55	1.00
	945	11.2	2.69	0.60	0.84	1.00	8.8	2.92	0.52	0.84	1.00	6.4	3.21	0.39	0.83	1.00	3.8	3.55	0.11	0.85	1.00
19°C	565	11.4	2.68	0.31	0.46	0.61	9.5	2.94	0.20	0.39	0.57	7.5	3.26	0.04	0.27	0.49	5.5	3.63	-0.25	0.07	0.37
	755	12.3	2.72	0.35	0.52	0.71	10.1	2.97	0.23	0.46	0.68	7.8	3.27	0.06	0.35	0.63	5.5	3.63	-0.27	0.15	0.55
	945	12.8	2.75	0.38	0.59	0.81	10.4	2.99	0.26	0.53	0.80	7.9	3.28	0.09	0.44	0.78	5.4	3.62	-0.26	0.26	0.76
22°C	565	12.9	2.73	0.19	0.33	0.45	10.9	3.00	0.08	0.24	0.40	9.0	3.32	-0.08	0.11	0.30	6.9	3.70	-0.35	-0.10	0.16
	755	13.8	2.78	0.20	0.37	0.52	11.6	3.03	0.08	0.28	0.47	9.3	3.34	-0.10	0.15	0.33	7.0	3.70	-0.41	-0.08	0.24
	945	14.4	2.81	0.20	0.40	0.59	12.0	3.06	0.08	0.31	0.54	9.5	3.35	-0.12	0.18	0.47	6.9	3.70	-0.48	-0.06	0.34

BLOWER DATA

BELT DRIVE | 3 TON

BLOWER TABLE INCLUDES RESISTANCE FOR BASE UNIT ONLY WITH DRY INDOOR COIL AND AIR FILTERS IN PLACE.

FOR ALL UNITS ADD:

- 1 - Any factory installed options air resistance (heat section, economizer, etc.).
- 2 - Any field installed accessories air resistance (duct resistance, diffuser, etc.).

See page 37 for blower motors and drives and wet coil and options/accessory air resistance data.

DOWNFLOW

Air Volume		External Static - Pa (in.w.g.)																													
		25 (0.10)		50 (0.20)		75 (0.30)		100 (0.40)		125 (0.50)		150 (0.60)		175 (0.70)		200 (0.80)		225 (0.90)		250 (1.00)											
L/s	cfm	Rev/min	BHP	Rev/min	BHP	Rev/min	BHP	Rev/min	BHP	Rev/min	BHP	Rev/min	BHP	Rev/min	BHP	Rev/min	BHP	Rev/min	BHP	Rev/min	BHP										
330	700	453	0.05	0.07	523	0.08	0.11	596	0.10	0.14	679	0.13	0.17	762	0.13	0.18	828	0.16	0.21	878	0.18	0.24	927	0.19	0.26	979	0.22	0.29	1029	0.23	0.31
380	800	471	0.07	0.09	542	0.10	0.13	614	0.12	0.16	696	0.14	0.19	777	0.16	0.21	841	0.17	0.23	889	0.19	0.26	938	0.22	0.29	990	0.23	0.31	1042	0.25	0.34
425	900	493	0.08	0.11	563	0.11	0.15	634	0.14	0.19	715	0.16	0.21	793	0.17	0.23	854	0.19	0.26	902	0.22	0.29	950	0.24	0.32	1002	0.25	0.34	1054	0.27	0.36
470	1000	517	0.10	0.14	587	0.13	0.18	657	0.16	0.21	736	0.18	0.24	811	0.19	0.26	869	0.22	0.29	916	0.24	0.32	964	0.26	0.35	1015	0.28	0.37	1067	0.30	0.40
520	1100	544	0.13	0.17	613	0.16	0.21	683	0.18	0.24	759	0.20	0.27	831	0.22	0.30	886	0.24	0.32	931	0.27	0.36	978	0.28	0.38	1028	0.31	0.41	1078	0.32	0.43
565	1200	574	0.15	0.20	643	0.18	0.24	711	0.20	0.27	784	0.22	0.30	852	0.25	0.33	904	0.27	0.36	947	0.29	0.39	993	0.31	0.42	1042	0.34	0.45	1091	0.35	0.47
615	1300	608	0.18	0.24	676	0.21	0.28	743	0.23	0.31	812	0.25	0.34	875	0.28	0.37	923	0.30	0.40	964	0.33	0.44	1010	0.34	0.46	1057	0.37	0.49	1104	0.38	0.51
660	1400	645	0.21	0.28	711	0.23	0.31	776	0.26	0.35	842	0.28	0.38	898	0.31	0.41	942	0.33	0.44	983	0.36	0.48	1028	0.38	0.51	1074	0.40	0.53	1120	0.42	0.56

Air Volume		External Static - Pa (in.w.g.)																													
		275 (1.10)		300 (1.20)		325 (1.30)		350 (1.40)		375 (1.50)		400 (1.60)		425 (1.70)		450 (1.80)		475 (1.90)		500 (2.00)											
L/s	cfm	Rev/min	BHP	Rev/min	BHP	Rev/min	BHP	Rev/min	BHP	Rev/min	BHP	Rev/min	BHP	Rev/min	BHP	Rev/min	BHP	Rev/min	BHP	Rev/min	BHP										
330	700	1078	0.25	0.33	1124	0.27	0.36	1180	0.31	0.41	1221	0.33	0.44	1260	0.35	0.47	1307	0.40	0.53	1345	0.42	0.56	1382	0.44	0.59	1420	0.46	0.62	1465	0.52	0.70
380	800	1091	0.27	0.36	1137	0.29	0.39	1180	0.31	0.41	1221	0.33	0.44	1260	0.35	0.47	1307	0.40	0.53	1345	0.42	0.56	1382	0.44	0.59	1420	0.46	0.62	1465	0.52	0.70
425	900	1105	0.29	0.39	1150	0.31	0.42	1192	0.34	0.45	1232	0.35	0.47	1270	0.37	0.50	1307	0.40	0.53	1345	0.42	0.56	1382	0.44	0.59	1420	0.46	0.62	1465	0.52	0.70
470	1000	1117	0.31	0.42	1162	0.34	0.45	1203	0.36	0.48	1242	0.38	0.51	1279	0.40	0.54	1316	0.43	0.57	1353	0.45	0.60	1390	0.47	0.63	1427	0.49	0.66	1465	0.52	0.70
520	1100	1126	0.34	0.46	1171	0.37	0.49	1212	0.39	0.52	1251	0.42	0.56	1288	0.44	0.59	1325	0.46	0.62	1361	0.48	0.65	1397	0.51	0.68	1433	0.53	0.71	1470	0.56	0.75
565	1200	1137	0.37	0.50	1180	0.40	0.54	1222	0.43	0.57	1260	0.45	0.60	1298	0.48	0.64	1334	0.50	0.67	1369	0.52	0.70	1404	0.54	0.73	1440	0.57	0.77	1477	0.60	0.80
615	1300	1149	0.41	0.55	1191	0.43	0.58	1232	0.46	0.62	1270	0.48	0.65	1307	0.51	0.69	1343	0.54	0.72	1378	0.57	0.76	1413	0.59	0.79	1449	0.61	0.82	1486	0.64	0.86
660	1400	1163	0.45	0.60	1204	0.47	0.63	1243	0.50	0.67	1281	0.53	0.71	1317	0.55	0.74	1353	0.58	0.78	1388	0.61	0.82	1423	0.63	0.85	1459	0.66	0.89	1496	0.69	0.92

BLOWER DATA

BELT DRIVE | 3 TON

BLOWER TABLE INCLUDES RESISTANCE FOR BASE UNIT ONLY WITH DRY INDOOR COIL AND AIR FILTERS IN PLACE.

FOR ALL UNITS ADD:

1 - Any factory installed options air resistance (heat section, economizer, etc.).

2 - Any field installed accessories air resistance (duct resistance, diffuser, etc.).

See page 37 for blower motors and drives and wet coil and options/accessory air resistance data.

HORIZONTAL

Air Volume		External Static - Pa (in.w.g.)																																
		25 (0.10)		50 (0.20)		75 (0.30)		100 (0.40)		125 (0.50)		150 (0.60)		175 (0.70)		200 (0.80)		225 (0.90)		250 (1.00)														
L/s	cfm	Rev/min	kW	BHP	Rev/min	kW	BHP	Rev/min	kW	BHP	Rev/min	kW	BHP	Rev/min	kW	BHP	Rev/min	kW	BHP	Rev/min	kW	BHP												
330	700	440	0.05	0.07	510	0.07	0.10	585	0.09	0.12	657	0.10	0.14	726	0.13	0.17	793	0.15	0.20	856	0.17	0.23	915	0.19	0.25	967	0.21	0.28	967	0.21	0.28	1016	0.23	0.31
380	800	456	0.06	0.08	526	0.08	0.11	600	0.10	0.14	672	0.12	0.16	739	0.14	0.19	804	0.16	0.22	866	0.19	0.25	923	0.21	0.28	975	0.23	0.31	1025	0.25	0.34			
425	900	474	0.07	0.10	544	0.10	0.13	617	0.12	0.16	688	0.13	0.18	754	0.16	0.21	818	0.18	0.24	877	0.20	0.27	932	0.22	0.30	984	0.25	0.33	1034	0.27	0.36			
470	1000	495	0.09	0.12	565	0.11	0.15	637	0.13	0.18	707	0.16	0.21	771	0.17	0.23	832	0.20	0.27	889	0.22	0.30	943	0.25	0.33	993	0.27	0.36	1043	0.29	0.39			
520	1100	518	0.10	0.14	588	0.13	0.18	659	0.16	0.21	727	0.17	0.23	789	0.19	0.26	848	0.22	0.30	903	0.25	0.33	954	0.28	0.37	1003	0.30	0.40	1052	0.32	0.43			
565	1200	544	0.13	0.17	613	0.16	0.21	682	0.18	0.24	748	0.20	0.27	809	0.22	0.29	866	0.25	0.33	918	0.28	0.37	967	0.30	0.40	1014	0.32	0.43	1062	0.34	0.46			
615	1300	572	0.16	0.21	640	0.18	0.24	707	0.20	0.27	771	0.22	0.30	830	0.25	0.33	884	0.28	0.37	934	0.31	0.41	981	0.33	0.44	1027	0.35	0.47	1073	0.37	0.50			
660	1400	602	0.18	0.24	669	0.21	0.28	733	0.23	0.31	795	0.25	0.34	851	0.28	0.37	903	0.31	0.41	950	0.34	0.45	995	0.37	0.49	1040	0.39	0.52	1086	0.41	0.55			

Air Volume		External Static - Pa (in.w.g.)																															
		275 (1.10)		300 (1.20)		325 (1.30)		350 (1.40)		375 (1.50)		400 (1.60)		425 (1.70)		450 (1.80)		475 (1.90)		500 (2.00)													
L/s	cfm	Rev/min	kW	BHP	Rev/min	kW	BHP	Rev/min	kW	BHP	Rev/min	kW	BHP	Rev/min	kW	BHP	Rev/min	kW	BHP	Rev/min	kW	BHP											
330	700	1065	0.25	0.33	---	---	---	---	---	---	---	---	---	---	---	---	---	---	---	---	---	---											
380	800	1075	0.27	0.36	1122	0.29	0.39	1164	0.31	0.42	1203	0.34	0.45	1241	0.35	0.47	---	---	---	---	---	---											
425	900	1086	0.29	0.39	1133	0.31	0.42	1174	0.34	0.45	1213	0.36	0.48	1250	0.38	0.51	1286	0.40	0.54	1322	0.43	0.57	1357	0.45	0.60	1392	0.48	0.64	---	---	---	---	---
470	1000	1094	0.32	0.43	1142	0.34	0.46	1183	0.37	0.49	1222	0.39	0.52	1259	0.41	0.55	1295	0.43	0.58	1330	0.46	0.62	1365	0.48	0.65	1400	0.51	0.68	1435	0.53	0.71		
520	1100	1102	0.34	0.46	1148	0.37	0.49	1191	0.40	0.53	1230	0.42	0.56	1267	0.45	0.60	1303	0.47	0.63	1338	0.49	0.66	1373	0.51	0.69	1408	0.54	0.73	1444	0.57	0.76		
565	1200	1110	0.37	0.50	1156	0.40	0.53	1198	0.43	0.57	1238	0.45	0.61	1275	0.48	0.64	1311	0.51	0.68	1346	0.53	0.71	1381	0.55	0.74	1416	0.58	0.78	1452	0.60	0.81		
615	1300	1120	0.40	0.54	1164	0.43	0.58	1207	0.46	0.62	1246	0.48	0.65	1283	0.51	0.69	1319	0.54	0.73	1354	0.57	0.76	1389	0.59	0.79	1424	0.62	0.83	1460	0.64	0.86		
660	1400	1131	0.44	0.59	1175	0.47	0.63	1216	0.50	0.67	1255	0.52	0.70	1292	0.55	0.74	1327	0.58	0.78	1362	0.60	0.81	1397	0.63	0.84	1432	0.66	0.88	1468	0.68	0.91		

BLOWER DATA

BELT DRIVE | 4 TON

BLOWER TABLE INCLUDES RESISTANCE FOR BASE UNIT ONLY WITH DRY INDOOR COIL AND AIR FILTERS IN PLACE.

FOR ALL UNITS ADD:

1 - Any factory installed options air resistance (heat section, economizer, etc.).

2 - Any field installed accessories air resistance (duct resistance, diffuser, etc.).

See page 37 for blower motors and drives and wet coil and options/accessory air resistance data.

DOWNFLOW

Air Volume		External Static - Pa (in.w.g.)																										
		25 (0.10)		50 (0.20)		75 (0.30)		100 (0.40)		125 (0.50)		150 (0.60)		175 (0.70)		200 (0.80)		225 (0.90)		250 (1.00)								
L/s	cfm	Rev/ min	kW	BHP	Rev/ min	kW	BHP	Rev/ min	kW	BHP	Rev/ min	kW	BHP	Rev/ min	kW	BHP	Rev/ min	kW	BHP	Rev/ min	kW	BHP						
425	900	502	0.09	0.12	573	0.11	0.15	0.18	0.22	0.28	802	0.18	0.24	861	0.19	0.26	908	0.22	0.29	957	0.24	0.32	1009	0.25	0.34	1061	0.28	0.37
470	1000	528	0.10	0.14	598	0.13	0.18	0.22	0.28	0.34	821	0.20	0.27	877	0.22	0.30	923	0.25	0.33	971	0.26	0.35	1022	0.28	0.38	1074	0.30	0.40
520	1100	557	0.13	0.17	626	0.16	0.21	0.25	0.31	0.37	841	0.22	0.30	894	0.25	0.33	939	0.27	0.36	986	0.29	0.39	1037	0.31	0.41	1087	0.33	0.44
565	1200	589	0.16	0.21	657	0.19	0.25	0.28	0.34	0.40	864	0.25	0.33	913	0.28	0.37	956	0.30	0.40	1003	0.32	0.43	1052	0.34	0.45	1100	0.36	0.48
615	1300	625	0.19	0.25	692	0.21	0.28	0.32	0.38	0.44	887	0.28	0.37	933	0.31	0.41	975	0.33	0.44	1021	0.35	0.47	1068	0.37	0.49	1115	0.39	0.52
660	1400	665	0.22	0.29	730	0.24	0.32	0.36	0.42	0.48	911	0.31	0.42	953	0.34	0.45	995	0.37	0.49	1040	0.39	0.52	1086	0.40	0.54	1131	0.43	0.57
710	1500	706	0.25	0.33	768	0.27	0.36	0.40	0.46	0.52	934	0.34	0.46	974	0.37	0.50	1015	0.40	0.54	1060	0.42	0.56	1105	0.44	0.59	1149	0.46	0.62
755	1600	746	0.28	0.37	805	0.30	0.40	0.44	0.50	0.56	957	0.39	0.52	996	0.41	0.55	1037	0.44	0.59	1081	0.46	0.62	1126	0.48	0.64	1167	0.51	0.68
800	1700	784	0.31	0.42	840	0.34	0.45	0.50	0.56	0.62	980	0.43	0.57	1019	0.45	0.61	1060	0.48	0.64	1104	0.50	0.67	1147	0.52	0.70	1187	0.55	0.74
850	1800	821	0.35	0.47	874	0.38	0.51	0.55	0.62	0.68	1006	0.47	0.63	1044	0.50	0.67	1085	0.52	0.70	1128	0.54	0.73	1170	0.57	0.77	1208	0.61	0.82
895	1900	857	0.40	0.53	906	0.43	0.57	0.62	0.68	0.74	1032	0.52	0.70	1071	0.54	0.73	1112	0.57	0.76	1154	0.60	0.80	1194	0.63	0.85	1230	0.67	0.90
Air Volume		External Static - Pa (in.w.g.)																										
		275 (1.10)		300 (1.20)		325 (1.30)		350 (1.40)		375 (1.50)		400 (1.60)		425 (1.70)		450 (1.80)		475 (1.90)		500 (2.00)								
L/s	cfm	Rev/ min	kW	BHP	Rev/ min	kW	BHP	Rev/ min	kW	BHP	Rev/ min	kW	BHP	Rev/ min	kW	BHP	Rev/ min	kW	BHP	Rev/ min	kW	BHP	Rev/ min	kW	BHP			
425	900	1111	0.29	0.39	1156	0.31	0.42	0.45	0.51	0.57	1275	0.38	0.51	1312	0.40	0.54	1349	0.42	0.56	1387	0.44	0.59	1424	0.46	0.62	1470	0.52	0.70
470	1000	1124	0.32	0.43	1168	0.34	0.46	0.49	0.56	0.62	1285	0.41	0.55	1322	0.43	0.58	1358	0.45	0.61	1395	0.48	0.64	1432	0.50	0.67	1477	0.56	0.75
520	1100	1134	0.35	0.47	1178	0.37	0.50	0.53	0.60	0.66	1295	0.45	0.60	1331	0.47	0.63	1367	0.49	0.66	1403	0.51	0.69	1439	0.54	0.72	1477	0.56	0.75
565	1200	1146	0.38	0.51	1189	0.40	0.54	0.58	0.65	0.71	1305	0.48	0.65	1341	0.51	0.68	1376	0.53	0.71	1411	0.55	0.74	1447	0.57	0.77	1485	0.60	0.81
615	1300	1159	0.41	0.55	1201	0.44	0.59	0.63	0.70	0.76	1315	0.52	0.70	1351	0.54	0.73	1386	0.57	0.77	1421	0.60	0.80	1457	0.62	0.83	1495	0.65	0.87
660	1400	1173	0.45	0.61	1214	0.48	0.64	0.68	0.75	0.81	1327	0.56	0.75	1362	0.59	0.79	1397	0.61	0.82	1432	0.64	0.86	1468	0.66	0.89	1506	0.69	0.93
710	1500	1189	0.49	0.66	1228	0.52	0.70	0.74	0.81	0.87	1339	0.60	0.81	1374	0.63	0.85	1409	0.66	0.89	1445	0.69	0.92	1481	0.72	0.96	1519	0.75	1.00
755	1600	1206	0.54	0.72	1244	0.57	0.76	0.80	0.87	0.93	1353	0.66	0.88	1388	0.69	0.92	1423	0.72	0.96	1459	0.75	1.00	1496	0.78	1.04	1535	0.81	1.08
800	1700	1224	0.59	0.79	1261	0.62	0.83	0.87	0.94	1.00	1369	0.71	0.95	1404	0.74	0.99	1440	0.77	1.03	1476	0.80	1.07	1513	0.84	1.12	1552	0.87	1.16
850	1800	1244	0.64	0.86	1280	0.68	0.91	0.95	1.02	1.08	1387	0.77	1.03	1422	0.80	1.07	1457	0.83	1.11	1494	0.87	1.16	1532	0.89	1.20	1570	0.92	1.24
895	1900	1265	0.71	0.95	1301	0.75	1.00	1.04	1.11	1.17	1406	0.84	1.12	1441	0.87	1.16	1477	0.89	1.20	1515	0.92	1.24	1553	0.96	1.29	1592	0.99	1.33

BLOWER DATA

BELT DRIVE | 4 TON

BLOWER TABLE INCLUDES RESISTANCE FOR BASE UNIT ONLY WITH DRY INDOOR COIL AND AIR FILTERS IN PLACE.

FOR ALL UNITS ADD:

- 1 - Any factory installed options air resistance (heat section, economizer, etc.).
- 2 - Any field installed accessories air resistance (duct resistance, diffuser, etc.).

See page 37 for blower motors and drives and wet coil and options/accessory air resistance data.

HORIZONTAL

Air Volume		External Static - Pa (in.w.g.)																													
		25 (0.10)		50 (0.20)		75 (0.30)		100 (0.40)		125 (0.50)		150 (0.60)		175 (0.70)		200 (0.80)		225 (0.90)		250 (1.00)											
L/s	cfm	Rev/min	kW	BHP	Rev/min	kW	BHP	Rev/min	kW	BHP	Rev/min	kW	BHP	Rev/min	kW	BHP	Rev/min	kW	BHP	Rev/min	kW	BHP									
425	900	483	0.07	0.10	554	0.10	0.13	627	0.12	0.16	699	0.14	0.19	765	0.16	0.22	826	0.18	0.24	882	0.20	0.27	935	0.22	0.30	986	0.25	0.33	1039	0.27	0.36
470	1000	505	0.09	0.12	576	0.12	0.16	648	0.14	0.19	719	0.16	0.21	784	0.18	0.24	842	0.20	0.27	896	0.22	0.30	947	0.25	0.33	998	0.28	0.37	1050	0.30	0.40
520	1100	530	0.11	0.15	601	0.13	0.18	671	0.16	0.21	741	0.18	0.24	804	0.20	0.27	860	0.22	0.30	912	0.25	0.34	961	0.28	0.37	1010	0.30	0.40	1060	0.32	0.43
565	1200	558	0.13	0.18	627	0.16	0.22	696	0.19	0.25	764	0.21	0.28	824	0.22	0.30	878	0.25	0.34	928	0.28	0.37	975	0.31	0.41	1023	0.33	0.44	1072	0.35	0.47
615	1300	588	0.16	0.22	656	0.19	0.25	723	0.21	0.28	788	0.23	0.31	846	0.25	0.34	897	0.28	0.38	945	0.31	0.42	990	0.34	0.45	1037	0.36	0.48	1084	0.38	0.51
660	1400	621	0.19	0.25	687	0.22	0.29	752	0.24	0.32	814	0.26	0.35	868	0.28	0.38	916	0.31	0.42	962	0.34	0.46	1006	0.37	0.50	1052	0.40	0.53	1098	0.42	0.56
710	1500	655	0.22	0.29	719	0.25	0.33	781	0.27	0.36	839	0.29	0.39	890	0.32	0.43	936	0.35	0.47	979	0.38	0.51	1023	0.41	0.55	1068	0.43	0.58	1113	0.45	0.61
755	1600	690	0.25	0.33	751	0.28	0.37	810	0.30	0.40	865	0.33	0.44	912	0.36	0.48	955	0.39	0.52	997	0.42	0.56	1041	0.45	0.60	1086	0.47	0.63	1129	0.49	0.66
800	1700	725	0.28	0.38	784	0.31	0.41	839	0.34	0.45	891	0.37	0.49	935	0.40	0.53	975	0.43	0.58	1017	0.46	0.62	1060	0.48	0.65	1104	0.51	0.68	1147	0.54	0.72
850	1800	761	0.31	0.42	816	0.34	0.46	868	0.37	0.50	916	0.41	0.55	957	0.44	0.59	997	0.48	0.64	1038	0.51	0.68	1081	0.53	0.71	1124	0.55	0.74	1165	0.59	0.79
895	1900	795	0.36	0.48	848	0.39	0.52	897	0.42	0.56	942	0.45	0.61	981	0.49	0.66	1020	0.52	0.70	1060	0.55	0.74	1103	0.57	0.77	1145	0.60	0.81	1183	0.63	0.85

Air Volume		External Static - Pa (in.w.g.)																													
		275 (1.10)		300 (1.20)		325 (1.30)		350 (1.40)		375 (1.50)		400 (1.60)		425 (1.70)		450 (1.80)		475 (1.90)		500 (2.00)											
L/s	cfm	Rev/min	kW	BHP	Rev/min	kW	BHP	Rev/min	kW	BHP	Rev/min	kW	BHP	Rev/min	kW	BHP	Rev/min	kW	BHP	Rev/min	kW	BHP									
425	900	1091	0.30	0.40	1138	0.32	0.43	1180	0.34	0.46	1220	0.37	0.49	1257	0.40	0.53	1293	0.42	0.56	1329	0.44	0.59	1364	0.46	0.62	1400	0.48	0.65	1435	0.51	0.69
470	1000	1101	0.32	0.43	1149	0.34	0.46	1190	0.37	0.50	1229	0.40	0.53	1266	0.43	0.57	1302	0.45	0.60	1338	0.47	0.63	1373	0.49	0.66	1408	0.52	0.70	1444	0.54	0.73
520	1100	1110	0.34	0.46	1156	0.37	0.50	1199	0.40	0.54	1238	0.43	0.57	1275	0.45	0.61	1311	0.48	0.64	1346	0.50	0.67	1381	0.53	0.71	1416	0.55	0.74	1452	0.58	0.78
565	1200	1119	0.37	0.50	1165	0.40	0.54	1207	0.43	0.58	1247	0.46	0.62	1284	0.48	0.65	1319	0.51	0.69	1355	0.54	0.72	1389	0.56	0.75	1425	0.59	0.79	1460	0.61	0.82
615	1300	1130	0.41	0.55	1175	0.44	0.59	1216	0.47	0.63	1255	0.49	0.66	1292	0.52	0.70	1328	0.55	0.74	1363	0.57	0.77	1398	0.60	0.80	1433	0.63	0.84	1469	0.65	0.87
660	1400	1143	0.45	0.60	1186	0.47	0.63	1226	0.50	0.67	1265	0.53	0.71	1302	0.56	0.75	1337	0.59	0.79	1372	0.61	0.82	1406	0.63	0.85	1441	0.66	0.89	1477	0.69	0.93
710	1500	1156	0.48	0.65	1198	0.51	0.69	1237	0.54	0.73	1275	0.57	0.77	1311	0.60	0.80	1346	0.63	0.84	1381	0.66	0.88	1415	0.68	0.91	1450	0.71	0.95	1486	0.73	0.98
755	1600	1171	0.52	0.70	1211	0.55	0.74	1249	0.58	0.78	1286	0.61	0.82	1321	0.64	0.86	1356	0.67	0.90	1390	0.69	0.93	1425	0.72	0.97	1460	0.75	1.01	1496	0.78	1.05
800	1700	1186	0.57	0.76	1225	0.60	0.80	1262	0.63	0.84	1298	0.66	0.88	1333	0.69	0.92	1367	0.72	0.96	1401	0.75	1.00	1436	0.77	1.03	1471	0.80	1.07	1507	0.84	1.12
850	1800	1202	0.62	0.83	1240	0.65	0.87	1276	0.68	0.91	1311	0.71	0.95	1345	0.74	0.99	1380	0.77	1.03	1413	0.80	1.07	1448	0.83	1.11	1483	0.86	1.15	1520	0.89	1.19
895	1900	1220	0.67	0.90	1256	0.70	0.94	1291	0.74	0.99	1326	0.77	1.03	1360	0.80	1.07	1393	0.82	1.10	1427	0.85	1.14	1462	0.88	1.18	1497	0.91	1.22	1534	0.95	1.27

BLOWER DATA

BELT DRIVE | 5 TON

BLOWER TABLE INCLUDES RESISTANCE FOR BASE UNIT ONLY WITH DRY INDOOR COIL AND AIR FILTERS IN PLACE.

FOR ALL UNITS ADD:

- 1 - Any factory installed options air resistance (heat section, economizer, etc.).
- 2 - Any field installed accessories air resistance (duct resistance, diffuser, etc.).

See page 37 for blower motors and drives and wet coil and options/accessory air resistance data.

DOWNFLOW

Air Volume		External Static - Pa (in. w.g.)																													
		25 (0.10)		50 (0.20)		75 (0.30)		100 (0.40)		125 (0.50)		150 (0.60)		175 (0.70)		200 (0.80)		225 (0.90)		250 (1.00)											
L/s	cfm	Rev/ min	BHP	Rev/ min	BHP	Rev/ min	BHP	Rev/ min	BHP	Rev/ min	BHP	Rev/ min	BHP	Rev/ min	BHP	Rev/ min	BHP	Rev/ min	BHP	Rev/ min	BHP										
520	1100	503	0.10	0.14	569	0.13	0.17	636	0.15	0.20	703	0.17	0.23	769	0.19	0.26	842	0.21	0.28	909	0.22	0.30	964	0.25	0.33	1008	0.27	0.36	1049	0.30	0.40
565	1200	525	0.12	0.16	590	0.15	0.20	657	0.17	0.23	722	0.19	0.26	787	0.22	0.29	857	0.23	0.31	921	0.25	0.34	974	0.28	0.37	1016	0.30	0.40	1056	0.32	0.43
615	1300	548	0.14	0.19	613	0.17	0.23	679	0.19	0.26	743	0.22	0.29	806	0.24	0.32	873	0.26	0.35	934	0.28	0.37	984	0.31	0.41	1026	0.33	0.44	1065	0.35	0.47
660	1400	574	0.16	0.22	638	0.19	0.26	702	0.22	0.30	765	0.25	0.33	827	0.27	0.36	891	0.29	0.39	949	0.31	0.41	996	0.34	0.45	1037	0.36	0.48	1076	0.38	0.51
710	1500	609	0.19	0.25	671	0.22	0.29	733	0.25	0.33	793	0.27	0.36	851	0.29	0.39	911	0.31	0.42	965	0.34	0.46	1010	0.37	0.49	1049	0.40	0.53	1088	0.42	0.56
755	1600	654	0.21	0.28	712	0.24	0.32	769	0.27	0.36	825	0.29	0.39	879	0.32	0.43	933	0.35	0.47	982	0.37	0.50	1024	0.40	0.54	1063	0.43	0.58	1101	0.45	0.61
800	1700	703	0.23	0.31	756	0.26	0.35	807	0.29	0.39	858	0.32	0.43	906	0.35	0.47	955	0.38	0.51	999	0.41	0.55	1039	0.44	0.59	1078	0.47	0.63	1117	0.49	0.66
850	1800	752	0.25	0.34	798	0.28	0.38	844	0.32	0.43	889	0.36	0.48	933	0.39	0.52	977	0.43	0.57	1017	0.45	0.61	1056	0.48	0.65	1094	0.51	0.68	1133	0.54	0.72
895	1900	796	0.28	0.38	837	0.32	0.43	878	0.36	0.48	918	0.40	0.53	958	0.43	0.58	997	0.46	0.62	1036	0.50	0.67	1074	0.53	0.71	1112	0.55	0.74	1151	0.57	0.77
945	2000	833	0.32	0.43	870	0.36	0.48	907	0.40	0.54	943	0.44	0.59	980	0.48	0.64	1018	0.51	0.69	1055	0.54	0.73	1093	0.57	0.77	1131	0.60	0.80	1170	0.62	0.83
990	2100	864	0.37	0.50	897	0.41	0.55	931	0.45	0.60	966	0.48	0.65	1002	0.53	0.71	1038	0.57	0.76	1075	0.60	0.80	1113	0.62	0.83	1151	0.65	0.87	1189	0.67	0.90
1040	2200	887	0.43	0.57	920	0.46	0.62	953	0.50	0.67	988	0.54	0.73	1024	0.58	0.78	1060	0.62	0.83	1097	0.65	0.87	1135	0.67	0.90	1173	0.70	0.94	1210	0.73	0.98
1085	2300	909	0.48	0.64	942	0.52	0.70	976	0.56	0.75	1011	0.60	0.81	1046	0.64	0.86	1083	0.68	0.91	1120	0.71	0.95	1157	0.73	0.98	1195	0.76	1.02	1231	0.79	1.06
1135	2400	931	0.54	0.72	965	0.58	0.78	999	0.62	0.83	1035	0.66	0.89	1071	0.70	0.94	1108	0.74	0.99	1144	0.77	1.03	1181	0.80	1.07	1217	0.82	1.10	1252	0.86	1.15

Air Volume		External Static - Pa (in. w.g.)																													
		275 (1.10)		300 (1.20)		325 (1.30)		350 (1.40)		375 (1.50)		400 (1.60)		425 (1.70)		450 (1.80)		475 (1.90)		500 (2.00)											
L/s	cfm	Rev/ min	BHP	Rev/ min	BHP	Rev/ min	BHP	Rev/ min	BHP	Rev/ min	BHP	Rev/ min	BHP	Rev/ min	BHP	Rev/ min	BHP	Rev/ min	BHP	Rev/ min	BHP										
520	1100	1090	0.31	0.42	1132	0.34	0.45	1175	0.35	0.47	1216	0.37	0.50	1257	0.40	0.53	1296	0.42	0.56	1334	0.44	0.59	1370	0.46	0.62	1405	0.48	0.65	1439	0.51	0.69
565	1200	1097	0.34	0.46	1139	0.37	0.49	1181	0.38	0.51	1222	0.40	0.54	1263	0.43	0.57	1301	0.45	0.60	1338	0.47	0.63	1374	0.50	0.67	1409	0.52	0.70	1443	0.55	0.74
615	1300	1106	0.37	0.50	1147	0.40	0.53	1189	0.41	0.55	1230	0.43	0.58	1270	0.45	0.61	1307	0.48	0.65	1344	0.51	0.68	1379	0.54	0.72	1414	0.56	0.75	1447	0.59	0.79
660	1400	1116	0.40	0.54	1157	0.43	0.57	1198	0.45	0.60	1239	0.47	0.63	1278	0.49	0.66	1315	0.52	0.70	1351	0.55	0.74	1385	0.57	0.77	1419	0.60	0.81	1452	0.63	0.85
710	1500	1128	0.44	0.59	1168	0.46	0.62	1209	0.48	0.64	1249	0.51	0.68	1287	0.53	0.71	1323	0.56	0.75	1358	0.59	0.79	1393	0.62	0.83	1426	0.65	0.87	1458	0.68	0.91
755	1600	1141	0.48	0.64	1181	0.50	0.67	1222	0.52	0.70	1261	0.54	0.73	1298	0.57	0.77	1333	0.60	0.81	1367	0.63	0.85	1401	0.66	0.89	1433	0.69	0.93	1465	0.72	0.97
800	1700	1156	0.51	0.69	1196	0.54	0.72	1235	0.56	0.75	1273	0.59	0.79	1309	0.62	0.83	1344	0.65	0.87	1377	0.68	0.91	1410	0.72	0.96	1442	0.75	1.00	1473	0.78	1.04
850	1800	1172	0.56	0.75	1211	0.58	0.78	1250	0.60	0.81	1287	0.63	0.85	1322	0.67	0.90	1355	0.70	0.94	1388	0.73	0.98	1420	0.76	1.02	1451	0.80	1.07	1482	0.83	1.11
895	1900	1190	0.60	0.81	1228	0.63	0.84	1265	0.66	0.88	1301	0.69	0.92	1335	0.72	0.97	1367	0.75	1.01	1399	0.78	1.05	1431	0.82	1.10	1462	0.85	1.14	1492	0.88	1.18
945	2000	1208	0.65	0.87	1245	0.68	0.91	1281	0.72	0.96	1316	0.75	1.00	1349	0.78	1.04	1380	0.81	1.09	1412	0.84	1.13	1443	0.88	1.18	1473	0.91	1.22	1503	0.94	1.26
990	2100	1227	0.70	0.94	1263	0.74	0.99	1298	0.78	1.04	1331	0.81	1.08	1363	0.84	1.13	1394	0.87	1.17	1425	0.91	1.22	1455	0.94	1.26	1485	0.98	1.31	1515	1.01	1.35
1040	2200	1246	0.76	1.02	1281	0.80	1.07	1315	0.84	1.12	1347	0.87	1.17	1379	0.91	1.22	1409	0.94	1.26	1439	0.98	1.31	1469	1.01	1.36	1499	1.04	1.40	1529	1.08	1.45
1085	2300	1266	0.83	1.11	1300	0.87	1.16	1333	0.91	1.22	1364	0.95	1.27	1395	0.98	1.32	1424	1.01	1.36	1454	1.05	1.41	1484	1.09	1.46	1513	1.12	1.50	1543	1.16	1.55
1135	2400	1286	0.89	1.20	1319	0.94	1.26	1351	0.98	1.32	1382	1.03	1.38	1411	1.07	1.43	1440	1.10	1.48	1470	1.13	1.52	1499	1.17	1.57	1528	1.20	1.61	1558	1.24	1.66

BLOWER DATA

BELT DRIVE | 5 TON

BLOWER TABLE INCLUDES RESISTANCE FOR BASE UNIT ONLY WITH DRY INDOOR COIL AND AIR FILTERS IN PLACE.

FOR ALL UNITS ADD:

- 1 - Any factory installed options air resistance (heat section, economizer, etc.).
- 2 - Any field installed accessories air resistance (duct resistance, diffuser, etc.).

See page 37 for blower motors and drives and wet coil and options/accessory air resistance data.

HORIZONTAL

Air Volume		External Static - Pa (in.w.g.)																													
		25 (0.10)		50 (0.20)		75 (0.30)		100 (0.40)		125 (0.50)		150 (0.60)		175 (0.70)		200 (0.80)		225 (0.90)		250 (1.00)											
L/s	cfm	Rev/ min	kW	BHP	Rev/ min	kW	BHP	Rev/ min	kW	BHP	Rev/ min	kW	BHP	Rev/ min	kW	BHP	Rev/ min	kW	BHP	Rev/ min	kW	BHP									
520	1100	503	0.10	0.14	569	0.13	0.17	636	0.15	0.20	703	0.17	0.23	769	0.19	0.26	842	0.21	0.28	909	0.22	0.30	964	0.25	0.33	1008	0.27	0.36	1049	0.30	0.40
565	1200	525	0.12	0.16	590	0.15	0.20	657	0.17	0.23	722	0.19	0.26	787	0.22	0.29	857	0.23	0.31	921	0.25	0.34	974	0.28	0.37	1016	0.30	0.40	1056	0.32	0.43
615	1300	548	0.14	0.19	613	0.17	0.23	679	0.19	0.26	743	0.22	0.29	806	0.24	0.32	873	0.26	0.35	934	0.28	0.37	984	0.31	0.41	1026	0.33	0.44	1065	0.35	0.47
665	1400	574	0.16	0.22	638	0.19	0.26	702	0.22	0.30	765	0.25	0.33	827	0.27	0.36	891	0.29	0.39	949	0.31	0.41	996	0.34	0.45	1037	0.36	0.48	1076	0.38	0.51
710	1500	609	0.19	0.25	671	0.22	0.29	733	0.25	0.33	793	0.27	0.36	851	0.29	0.39	911	0.31	0.42	965	0.34	0.46	1010	0.37	0.49	1049	0.40	0.53	1088	0.42	0.56
755	1600	654	0.21	0.28	712	0.24	0.32	769	0.27	0.36	825	0.29	0.39	879	0.32	0.43	933	0.35	0.47	982	0.37	0.50	1024	0.40	0.54	1063	0.43	0.58	1101	0.45	0.61
800	1700	703	0.23	0.31	756	0.26	0.35	807	0.29	0.39	858	0.32	0.43	906	0.35	0.47	955	0.38	0.51	999	0.41	0.55	1039	0.44	0.59	1078	0.47	0.63	1117	0.49	0.66
850	1800	752	0.25	0.34	798	0.28	0.38	844	0.32	0.43	889	0.36	0.48	933	0.39	0.52	977	0.43	0.57	1017	0.45	0.61	1056	0.48	0.65	1094	0.51	0.68	1133	0.54	0.72
895	1900	796	0.28	0.38	837	0.32	0.43	878	0.36	0.48	918	0.40	0.53	958	0.43	0.58	997	0.46	0.62	1036	0.50	0.67	1074	0.53	0.71	1112	0.55	0.74	1151	0.57	0.77
945	2000	833	0.32	0.43	870	0.36	0.48	907	0.40	0.54	943	0.44	0.59	980	0.48	0.64	1018	0.51	0.69	1055	0.54	0.73	1093	0.57	0.77	1131	0.60	0.80	1170	0.62	0.83
990	2100	864	0.37	0.50	897	0.41	0.55	931	0.45	0.60	966	0.48	0.65	1002	0.53	0.71	1038	0.57	0.76	1075	0.60	0.80	1113	0.62	0.83	1151	0.65	0.87	1189	0.67	0.90
1040	2200	887	0.43	0.57	920	0.46	0.62	953	0.50	0.67	988	0.54	0.73	1024	0.58	0.78	1060	0.62	0.83	1097	0.65	0.87	1135	0.67	0.90	1173	0.70	0.94	1210	0.73	0.98
1085	2300	909	0.48	0.64	942	0.52	0.70	976	0.56	0.75	1011	0.60	0.81	1046	0.64	0.86	1083	0.68	0.91	1120	0.71	0.95	1157	0.73	0.98	1195	0.76	1.02	1231	0.79	1.06
1135	2400	931	0.54	0.72	965	0.58	0.78	999	0.62	0.83	1035	0.66	0.89	1071	0.70	0.94	1108	0.74	0.99	1144	0.77	1.03	1181	0.80	1.07	1217	0.82	1.10	1252	0.86	1.15

Air Volume		External Static - Pa (in.w.g.)																													
		275 (1.10)		300 (1.20)		325 (1.30)		350 (1.40)		375 (1.50)		400 (1.60)		425 (1.70)		450 (1.80)		475 (1.90)		500 (2.00)											
L/s	cfm	Rev/ min	kW	BHP	Rev/ min	kW	BHP	Rev/ min	kW	BHP	Rev/ min	kW	BHP	Rev/ min	kW	BHP	Rev/ min	kW	BHP	Rev/ min	kW	BHP									
520	1100	1090	0.31	0.42	1132	0.34	0.45	1175	0.35	0.47	1216	0.37	0.50	1257	0.40	0.53	1296	0.42	0.56	1334	0.44	0.59	1370	0.46	0.62	1405	0.48	0.65	1439	0.51	0.69
565	1200	1097	0.34	0.46	1139	0.37	0.49	1181	0.38	0.51	1222	0.40	0.54	1263	0.43	0.57	1301	0.45	0.60	1338	0.47	0.63	1374	0.50	0.67	1409	0.52	0.70	1443	0.55	0.74
615	1300	1106	0.37	0.50	1147	0.40	0.53	1189	0.41	0.55	1230	0.43	0.58	1270	0.45	0.61	1307	0.48	0.65	1344	0.51	0.68	1379	0.54	0.72	1414	0.56	0.75	1447	0.59	0.79
665	1400	1116	0.40	0.54	1157	0.43	0.57	1198	0.45	0.60	1239	0.47	0.63	1278	0.49	0.66	1315	0.52	0.70	1351	0.55	0.74	1385	0.57	0.77	1419	0.60	0.81	1452	0.63	0.85
710	1500	1128	0.44	0.59	1168	0.46	0.62	1209	0.48	0.64	1249	0.51	0.68	1287	0.53	0.71	1323	0.56	0.75	1358	0.59	0.79	1393	0.62	0.83	1426	0.65	0.87	1458	0.68	0.91
755	1600	1141	0.48	0.64	1181	0.50	0.67	1222	0.52	0.70	1261	0.54	0.73	1298	0.57	0.77	1333	0.60	0.81	1367	0.63	0.85	1401	0.66	0.89	1433	0.69	0.93	1465	0.72	0.97
800	1700	1156	0.51	0.69	1196	0.54	0.72	1235	0.56	0.75	1273	0.59	0.79	1309	0.62	0.83	1344	0.65	0.87	1377	0.68	0.91	1410	0.72	0.96	1442	0.75	1.00	1473	0.78	1.04
850	1800	1172	0.56	0.75	1211	0.58	0.78	1250	0.60	0.81	1287	0.63	0.85	1322	0.67	0.90	1355	0.70	0.94	1388	0.73	0.98	1420	0.76	1.02	1451	0.80	1.07	1482	0.83	1.11
895	1900	1190	0.60	0.81	1228	0.63	0.84	1265	0.66	0.88	1301	0.69	0.92	1335	0.72	0.97	1367	0.75	1.01	1399	0.78	1.05	1431	0.82	1.10	1462	0.85	1.14	1492	0.88	1.18
945	2000	1208	0.65	0.87	1245	0.68	0.91	1281	0.72	0.96	1316	0.75	1.00	1349	0.78	1.04	1380	0.81	1.09	1412	0.84	1.13	1443	0.88	1.18	1473	0.91	1.22	1503	0.94	1.26
990	2100	1227	0.70	0.94	1263	0.74	0.99	1298	0.78	1.04	1331	0.81	1.08	1363	0.84	1.13	1394	0.87	1.17	1425	0.91	1.22	1455	0.94	1.26	1485	0.98	1.31	1515	1.01	1.35
1040	2200	1246	0.76	1.02	1281	0.80	1.07	1315	0.84	1.12	1347	0.87	1.17	1379	0.91	1.22	1409	0.94	1.26	1439	0.98	1.31	1469	1.01	1.36	1499	1.04	1.40	1529	1.08	1.45
1085	2300	1266	0.83	1.11	1300	0.87	1.16	1333	0.91	1.22	1364	0.95	1.27	1395	0.98	1.32	1424	1.01	1.36	1454	1.05	1.41	1484	1.09	1.46	1513	1.12	1.50	1543	1.16	1.55
1135	2400	1286	0.89	1.20	1319	0.94	1.26	1351	0.98	1.32	1382	1.03	1.38	1411	1.07	1.43	1440	1.10	1.48	1470	1.13	1.52	1499	1.17	1.57	1528	1.20	1.61	1558	1.24	1.66

BLOWER DATA

BELT DRIVE | 6 TON

BLOWER TABLE INCLUDES RESISTANCE FOR BASE UNIT ONLY WITH DRY INDOOR COIL AND AIR FILTERS IN PLACE.

FOR ALL UNITS ADD:

- 1 - Any factory installed options air resistance (heat section, economizer, etc.).
- 2 - Any field installed accessories air resistance (duct resistance, diffuser, etc.).

See page 37 for blower motors and drives and wet coil and options/accessory air resistance data.

DOWNFLOW

Air Volume		External Static - Pa (in.w.g.)																													
		25 (0.10)		50 (0.20)		75 (0.30)		100 (0.40)		125 (0.50)		150 (0.60)		175 (0.70)		200 (0.80)		225 (0.90)		250 (1.00)											
L/s	cfm	Rev/min	kw	BHP	Rev/min	kw	BHP	Rev/min	kw	BHP	Rev/min	kw	BHP	Rev/min	kw	BHP	Rev/min	kw	BHP	Rev/min	kw	BHP									
895	1900	510	0.34	0.45	544	0.37	0.5	579	0.41	0.55	614	0.45	0.6	649	0.48	0.65	684	0.52	0.7	718	0.55	0.74	752	0.59	0.79	784	0.62	0.83	812	0.66	0.88
945	2000	526	0.37	0.49	560	0.41	0.55	595	0.45	0.6	629	0.48	0.65	663	0.52	0.7	697	0.56	0.75	730	0.59	0.79	763	0.63	0.84	794	0.66	0.88	820	0.69	0.93
990	2100	542	0.40	0.54	576	0.44	0.59	610	0.48	0.65	644	0.52	0.7	678	0.56	0.75	711	0.60	0.8	743	0.63	0.84	775	0.66	0.89	804	0.70	0.94	830	0.73	0.98
1040	2200	560	0.44	0.59	593	0.48	0.64	627	0.52	0.7	660	0.56	0.75	693	0.60	0.8	725	0.63	0.85	757	0.67	0.9	787	0.70	0.94	814	0.74	0.99	840	0.77	1.03
1085	2300	578	0.48	0.64	610	0.52	0.7	644	0.56	0.75	676	0.60	0.81	709	0.64	0.86	740	0.68	0.91	770	0.71	0.95	799	0.75	1	826	0.78	1.05	851	0.81	1.09
1135	2400	597	0.52	0.7	629	0.56	0.75	661	0.60	0.81	693	0.64	0.86	725	0.68	0.91	755	0.72	0.96	784	0.75	1.01	812	0.79	1.06	838	0.83	1.11	862	0.86	1.15
1180	2500	617	0.57	0.76	648	0.60	0.81	679	0.65	0.87	710	0.69	0.92	741	0.72	0.97	770	0.77	1.03	799	0.81	1.08	825	0.84	1.13	850	0.87	1.17	875	0.91	1.22
1225	2600	637	0.61	0.82	667	0.65	0.87	698	0.69	0.93	728	0.73	0.98	758	0.78	1.04	786	0.81	1.09	814	0.86	1.15	839	0.89	1.2	864	0.92	1.24	887	0.95	1.28
1275	2700	658	0.66	0.88	687	0.70	0.94	717	0.75	1	746	0.78	1.05	775	0.83	1.11	802	0.87	1.16	829	0.91	1.22	853	0.95	1.27	877	0.98	1.31	901	1.01	1.36
1320	2800	679	0.71	0.95	708	0.75	1.01	736	0.80	1.07	764	0.84	1.12	792	0.88	1.18	819	0.92	1.24	844	0.97	1.3	868	1.01	1.35	892	1.04	1.39	915	1.07	1.43
1370	2900	701	0.76	1.02	728	0.81	1.08	756	0.85	1.14	783	0.89	1.2	809	0.94	1.26	835	0.98	1.32	860	1.03	1.38	884	1.07	1.43	907	1.10	1.47	930	1.13	1.52

Air Volume		External Static - Pa (in.w.g.)																													
		275 (1.10)		300 (1.20)		325 (1.30)		350 (1.40)		375 (1.50)		400 (1.60)		425 (1.70)		450 (1.80)		475 (1.90)		500 (2.00)											
L/s	cfm	Rev/min	kw	BHP	Rev/min	kw	BHP	Rev/min	kw	BHP	Rev/min	kw	BHP	Rev/min	kw	BHP	Rev/min	kw	BHP	Rev/min	kw	BHP									
895	1900	837	0.69	0.92	861	0.72	0.96	886	0.75	1	913	0.78	1.04	939	0.80	1.07	966	0.83	1.11	992	0.87	1.16	1017	0.90	1.21	1041	0.95	1.27	1065	0.99	1.33
945	2000	845	0.72	0.97	870	0.75	1.01	895	0.78	1.05	921	0.81	1.09	948	0.84	1.12	974	0.87	1.17	999	0.91	1.22	1023	0.95	1.27	1047	0.99	1.33	1070	1.04	1.39
990	2100	855	0.76	1.02	879	0.79	1.06	904	0.82	1.1	930	0.85	1.14	956	0.88	1.18	982	0.91	1.22	1006	0.95	1.28	1030	1.00	1.34	1053	1.04	1.4	1075	1.09	1.46
1040	2200	865	0.81	1.08	889	0.84	1.12	914	0.86	1.15	940	0.89	1.19	966	0.92	1.24	990	0.96	1.29	1014	1.00	1.34	1037	1.05	1.41	1059	1.10	1.47	1081	1.15	1.54
1085	2300	875	0.84	1.13	900	0.87	1.17	925	0.90	1.21	951	0.93	1.25	976	0.97	1.3	999	1.01	1.35	1022	1.05	1.41	1044	1.10	1.48	1066	1.16	1.55	1087	1.21	1.62
1135	2400	887	0.89	1.19	912	0.92	1.23	936	0.95	1.27	961	0.98	1.32	986	1.02	1.37	1009	1.07	1.43	1031	1.11	1.49	1052	1.17	1.57	1073	1.22	1.64	1094	1.28	1.71
1180	2500	899	0.93	1.25	923	0.96	1.29	948	1.00	1.34	973	1.04	1.39	996	1.07	1.44	1018	1.13	1.51	1039	1.18	1.58	1060	1.23	1.65	1080	1.29	1.73	1101	1.34	1.8
1225	2600	912	0.98	1.32	936	1.01	1.36	960	1.05	1.41	984	1.09	1.46	1007	1.13	1.52	1028	1.19	1.59	1049	1.25	1.67	1069	1.30	1.75	1089	1.36	1.82	1109	1.41	1.89
1275	2700	925	1.04	1.4	949	1.07	1.44	973	1.11	1.49	996	1.16	1.55	1018	1.20	1.61	1038	1.26	1.69	1058	1.31	1.76	1078	1.37	1.84	1098	1.43	1.92	1118	1.48	1.99
1320	2800	939	1.10	1.47	962	1.13	1.52	985	1.17	1.57	1008	1.22	1.64	1029	1.28	1.71	1049	1.33	1.79	1069	1.39	1.87	1088	1.45	1.94	1107	1.51	2.02	1127	1.56	2.09
1370	2900	953	1.16	1.56	976	1.20	1.61	998	1.25	1.67	1020	1.29	1.73	1041	1.35	1.81	1060	1.41	1.89	1079	1.48	1.98	1098	1.54	2.06	1117	1.59	2.13	1137	1.65	2.21

BLOWER DATA

BELT DRIVE | 6 TON

BLOWER TABLE INCLUDES RESISTANCE FOR BASE UNIT ONLY WITH DRY INDOOR COIL AND AIR FILTERS IN PLACE.

FOR ALL UNITS ADD:

- 1 - Any factory installed options air resistance (heat section, economizer, etc.).
- 2 - Any field installed accessories air resistance (duct resistance, diffuser, etc.).

See page 37 for blower motors and drives and wet coil and options/accessory air resistance data.

HORIZONTAL

Air Volume		External Static - Pa (in.w.g.)																													
		25 (0.10)		50 (0.20)		75 (0.30)		100 (0.40)		125 (0.50)		150 (0.60)		175 (0.70)		200 (0.80)		225 (0.90)		250 (1.00)											
L/s	cfm	Rev/ min	kW	BHP	Rev/ min	kW	BHP	Rev/ min	kW	BHP	Rev/ min	kW	BHP	Rev/ min	kW	BHP	Rev/ min	kW	BHP	Rev/ min	kW	BHP									
895	1900	485	0.41	0.55	516	0.43	0.57	549	0.44	0.59	583	0.46	0.62	618	0.48	0.65	654	0.51	0.69	689	0.54	0.73	724	0.57	0.77	758	0.61	0.82	790	0.64	0.86
945	2000	499	0.44	0.59	531	0.45	0.61	563	0.47	0.63	597	0.49	0.66	631	0.52	0.70	666	0.54	0.73	701	0.57	0.77	734	0.61	0.82	767	0.64	0.86	798	0.68	0.91
990	2100	514	0.47	0.63	546	0.48	0.65	578	0.51	0.68	611	0.53	0.71	645	0.55	0.74	679	0.58	0.78	712	0.61	0.82	745	0.64	0.86	777	0.68	0.91	806	0.72	0.96
1040	2200	530	0.51	0.68	562	0.52	0.70	594	0.54	0.73	627	0.57	0.76	660	0.59	0.79	693	0.62	0.83	725	0.65	0.87	757	0.69	0.92	787	0.72	0.96	816	0.75	1.01
1085	2300	548	0.54	0.73	579	0.56	0.75	610	0.58	0.78	643	0.60	0.81	675	0.63	0.85	707	0.66	0.88	738	0.69	0.93	769	0.72	0.97	798	0.76	1.02	826	0.79	1.06
1135	2400	566	0.58	0.78	596	0.60	0.81	628	0.63	0.84	659	0.65	0.87	691	0.67	0.90	722	0.70	0.94	752	0.73	0.98	782	0.77	1.03	810	0.81	1.08	837	0.84	1.12
1180	2500	585	0.63	0.84	615	0.64	0.86	645	0.67	0.90	676	0.69	0.93	707	0.72	0.96	737	0.75	1.00	767	0.78	1.05	795	0.81	1.09	822	0.85	1.14	848	0.89	1.19
1225	2600	604	0.67	0.90	634	0.69	0.93	664	0.72	0.96	694	0.74	0.99	724	0.77	1.03	753	0.80	1.07	781	0.83	1.11	809	0.86	1.15	835	0.89	1.20	861	0.93	1.25
1275	2700	624	0.72	0.96	653	0.74	0.99	682	0.76	1.02	712	0.79	1.06	741	0.81	1.09	769	0.84	1.13	796	0.88	1.18	823	0.91	1.22	849	0.95	1.27	873	0.98	1.32
1320	2800	645	0.76	1.02	673	0.78	1.05	701	0.81	1.09	730	0.84	1.12	758	0.87	1.16	785	0.89	1.20	812	0.93	1.25	838	0.96	1.29	862	1.00	1.34	886	1.04	1.39
1370	2900	665	0.81	1.09	693	0.84	1.12	721	0.87	1.16	748	0.89	1.19	775	0.92	1.23	802	0.95	1.27	827	0.98	1.32	852	1.01	1.36	877	1.05	1.41	900	1.09	1.46

Air Volume		External Static - Pa (in.w.g.)																													
		275 (1.10)		300 (1.20)		325 (1.30)		350 (1.40)		375 (1.50)		400 (1.60)		425 (1.70)		450 (1.80)		475 (1.90)		500 (2.00)											
L/s	cfm	Rev/ min	kW	BHP	Rev/ min	kW	BHP	Rev/ min	kW	BHP	Rev/ min	kW	BHP	Rev/ min	kW	BHP	Rev/ min	kW	BHP	Rev/ min	kW	BHP									
895	1900	819	0.67	0.90	846	0.70	0.94	871	0.73	0.98	897	0.76	1.02	922	0.78	1.05	948	0.81	1.09	974	0.84	1.13	999	0.88	1.18	1025	0.92	1.23	1050	0.95	1.28
945	2000	826	0.71	0.95	852	0.74	0.99	877	0.77	1.03	902	0.79	1.06	928	0.82	1.10	953	0.85	1.14	979	0.88	1.18	1004	0.92	1.23	1029	0.95	1.28	1054	1.00	1.34
990	2100	834	0.75	1.00	859	0.78	1.04	884	0.81	1.08	909	0.84	1.12	934	0.86	1.15	960	0.89	1.20	985	0.92	1.24	1010	0.96	1.29	1034	1.01	1.35	1058	1.04	1.40
1040	2200	842	0.78	1.05	868	0.82	1.1	892	0.84	1.13	917	0.87	1.17	942	0.90	1.21	967	0.94	1.26	992	0.97	1.3	1016	1.01	1.36	1040	1.05	1.41	1063	1.10	1.47
1085	2300	852	0.83	1.11	877	0.86	1.15	901	0.89	1.19	926	0.92	1.23	950	0.95	1.27	975	0.98	1.32	999	1.02	1.37	1023	1.06	1.42	1046	1.10	1.48	1069	1.15	1.54
1135	2400	862	0.87	1.17	887	0.90	1.21	911	0.93	1.25	935	0.97	1.30	959	1.00	1.34	983	1.04	1.39	1007	1.07	1.44	1030	1.12	1.50	1053	1.16	1.56	1075	1.21	1.62
1180	2500	873	0.92	1.23	897	0.95	1.28	921	0.98	1.32	945	1.01	1.36	969	1.05	1.41	992	1.09	1.46	1016	1.13	1.52	1038	1.18	1.58	1060	1.22	1.64	1082	1.27	1.70
1225	2600	885	0.97	1.30	909	1.00	1.34	932	1.04	1.39	955	1.07	1.43	979	1.11	1.49	1002	1.15	1.54	1025	1.19	1.6	1047	1.24	1.66	1069	1.29	1.73	1090	1.33	1.79
1275	2700	897	1.02	1.37	920	1.05	1.41	944	1.09	1.46	967	1.13	1.51	990	1.17	1.57	1012	1.21	1.62	1034	1.26	1.69	1056	1.30	1.75	1077	1.36	1.82	1098	1.41	1.89
1320	2800	910	1.07	1.44	933	1.11	1.49	955	1.15	1.54	978	1.19	1.60	1001	1.23	1.65	1023	1.28	1.72	1044	1.33	1.78	1066	1.38	1.85	1086	1.43	1.92	1107	1.48	1.99
1370	2900	923	1.13	1.52	945	1.17	1.57	968	1.22	1.63	990	1.25	1.68	1012	1.30	1.75	1034	1.35	1.81	1055	1.40	1.88	1076	1.45	1.95	1096	1.51	2.02	1116	1.55	2.09

BLOWER DATA

BELT DRIVE KIT SPECIFICATIONS - 036-060

Model No.	Motor kW		Motor HP		No. of Speeds	Drive Kits and rev/min Range					
	Nom.	Max.	Nom.	Max.		A01	A02	A03	A05	A06	A07
036	0.47	0.54	0.63	0.72	2	low 374-561 high 561-842	---	---	---	---	---
	0.62	0.71	0.83	0.95	2	---	---	---	low 498-748 high 748-1122	---	---
048	0.47	0.54	0.63	0.72	2	---	low 414-621 high 621-931	---	---	---	---
	1.24	1.42	1.66	1.91	2	---	---	---	---	low 595-794 high 893-1191	---
060	0.62	0.71	0.83	0.95	2	---	---	low 463-694 high 694-1042	---	---	---
	1.24	1.42	1.66	1.91	2	---	---	---	---	---	low 673-860 high 1010-1290

NOTE - Using total air volume and system static pressure requirements determine from blower performance tables rev/min and motor output required. Maximum usable output of motors furnished are shown. If motors of comparable output are used, be sure to keep within the service factor limitations outlined on the motor nameplate.

BELT DRIVE KIT SPECIFICATIONS - 072-074

Model No.	Motor kW		Motor HP		No. of Speeds	Drive Kits and rev/min Range		
	Nom.	Max.	Nom.	Max.		AA02	AA03	AA04
072	1.5	1.7	2	2.3	1	527-729	665-921	768-1023
074	0.75	0.88	1	1.15	2	---	665-921	768-1023
	1.5	1.7	2	2.3	2	---	665-921	768-1023

NOTE - Using total air volume and system static pressure requirements determine from blower performance tables rev/min and motor output required. Maximum usable output of motors furnished are shown. If motors of comparable output are used, be sure to keep within the service factor limitations outlined on the motor nameplate.

FACTORY INSTALLED OPTIONS/FIELD INSTALLED ACCESSORY AIR RESISTANCE - in. w.g.

Air Volume cfm	Wet Indoor Coil						Humiditrol Dehumidification Coil	Gas Heating				Econo-mizer	Filters	
	036		048		060, 072, 074			Medium Heat	High Heat		MERV 8		MERV 13	

036-048 MODELS

L/s	cfm	Pa	in. w.g.	Pa	in. w.g.	Pa	in. w.g.	Pa	in. w.g.	Pa	in. w.g.	Pa	in. w.g.	Pa	in. w.g.	Pa	in. w.g.	Pa	in. w.g.
380	800	2	0.01	2	0.01	---	---	0	0.00	5	0.02	5	0.02	10	0.04	10	0.04	12	0.05
470	1000	5	0.02	5	0.02	---	---	0	0.00	5	0.02	5	0.02	10	0.04	10	0.04	17	0.07
565	1200	7	0.03	10	0.04	---	---	2	0.01	5	0.02	5	0.02	10	0.04	10	0.04	17	0.07
660	1400	10	0.04	12	0.05	---	---	5	0.02	5	0.02	7	0.03	10	0.04	10	0.04	17	0.07
755	1600	12	0.05	15	0.06	---	---	7	0.03	7	0.03	10	0.04	10	0.04	10	0.04	17	0.07
850	1800	15	0.06	17	0.07	---	---	10	0.04	10	0.04	12	0.05	12	0.05	10	0.04	17	0.07
945	2000	20	0.08	22	0.09	---	---	10	0.04	10	0.04	15	0.06	12	0.05	12	0.05	20	0.08

060, 072, 074 MODELS

L/s	cfm	Pa	in. w.g.	Pa	in. w.g.	Pa	in. w.g.	Pa	in. w.g.	Pa	in. w.g.	Pa	in. w.g.	Pa	in. w.g.	Pa	in. w.g.	Pa	in. w.g.
470	1000	---	---	---	---	5	0.02	0	0.00	5	0.02	5	0.02	10	0.04	7	0.03	12	0.05
565	1200	---	---	---	---	10	0.04	0	0.00	5	0.02	5	0.02	10	0.04	7	0.03	17	0.07
660	1400	---	---	---	---	12	0.05	2	0.01	5	0.02	7	0.03	10	0.04	10	0.04	17	0.07
755	1600	---	---	---	---	17	0.07	5	0.02	7	0.03	10	0.04	10	0.04	10	0.04	17	0.07
850	1800	---	---	---	---	20	0.08	5	0.02	7	0.03	12	0.05	12	0.05	12	0.05	17	0.07
945	2000	---	---	---	---	24	0.10	7	0.03	10	0.04	15	0.06	12	0.05	12	0.05	17	0.07
1040	2200	---	---	---	---	27	0.11	10	0.04	10	0.04	17	0.07	12	0.05	12	0.05	20	0.08
1135	2400	---	---	---	---	32	0.13	10	0.04	12	0.05	20	0.08	12	0.05	12	0.05	20	0.08
1225	2600	---	---	---	---	37	0.15	12	0.05	12	0.05	22	0.09	15	0.06	12	0.05	20	0.08
1321	2800	---	---	---	---	40	0.16	12	0.05	15	0.06	24	0.10	15	0.06	12	0.05	20	0.08
1416	3000	---	---	---	---	45	0.18	15	0.06	17	0.07	27	0.11	15	0.06	12	0.05	20	0.08

BLOWER DATA

POWER EXHAUST FAN PERFORMANCE

Return Air System Static Pressure		Air Volume Exhausted	
Pa	in. w.g.	L/s	cfm
0	0.00	787	1665
12	0.05	783	1660
25	0.10	757	1605
37	0.15	712	1510
50	0.20	654	1385
62	0.25	593	1255
75	0.30	531	1125
87	0.35	476	1010

CEILING DIFFUSERS AIR RESISTANCE

Air Volume		RTD9-65S Step-Down Diffuser						FD9-65S Flush Diffuser		RTD11-95S Step-Down Diffuser						FD11-95S Flush Diffuser	
		2 Ends Open		1 Side & 2 Ends Open		All Ends & Sides Open				2 Ends Open		1 Side & 2 Ends Open		All Ends & Sides Open			
L/s	cfm	Pa	in. w.g.	Pa	in. w.g.	Pa	in. w.g.	Pa	in. w.g.	Pa	in. w.g.	Pa	in. w.g.	Pa	in. w.g.	Pa	in. w.g.
378	800	37	0.15	32	0.13	27	0.11	27	0.11	---	---	---	---	---	---	---	---
472	1000	47	0.19	40	0.16	35	0.14	35	0.14	---	---	---	---	---	---	---	---
566	1200	62	0.25	50	0.20	42	0.17	42	0.17	---	---	---	---	---	---	---	---
661	1400	82	0.33	65	0.26	50	0.20	50	0.20	---	---	---	---	---	---	---	---
755	1600	107	0.43	80	0.32	50	0.20	60	0.24	---	---	---	---	---	---	---	---
849	1800	139	0.56	99	0.40	75	0.30	75	0.30	32	0.13	27	0.11	22	0.09	22	0.09
944	2000	182	0.73	124	0.50	90	0.36	90	0.36	37	0.15	32	0.13	27	0.11	25	0.10
1038	2200	236	0.95	157	0.63	109	0.44	109	0.44	45	0.18	37	0.15	30	0.12	30	0.12
1133	2400	---	---	---	---	---	---	---	---	52	0.21	45	0.18	37	0.15	35	0.14
1227	2600	---	---	---	---	---	---	---	---	60	0.24	52	0.21	45	0.18	42	0.17
1321	2800	---	---	---	---	---	---	---	---	67	0.27	60	0.24	52	0.21	50	0.20
1416	3000	---	---	---	---	---	---	---	---	80	0.32	72	0.29	62	0.25	62	0.25

CEILING DIFFUSER AIR THROW DATA

Air Volume		¹ Effective Throw			
L/s	cfm	m		ft.	
Model No.		RTD9-65S		FD9-65S	
378	800	3 - 5		10 - 17	
472	1000	3 - 5		10 - 17	
566	1200	3 - 5		11 - 18	
661	1400	3 - 6		12 - 19	
755	1600	3 - 6		12 - 20	
849	1800	4 - 6		13 - 21	
944	2000	4 - 7		14 - 23	
1038	2200	5 - 8		16 - 25	
Model No.		RTD11-95S		FD11-95S	
1227	2600	7 - 9		24 - 29	
1321	2800	8 - 9		25 - 30	
1416	3000	8 - 10		27 - 33	

¹ Effective throw based on terminal velocities of 23 m (75 ft.) per minute.

ELECTRICAL DATA

Model No.		LGH036S4	LGH048S4	LGH060S4	LGH072H4	LGH074H4			
¹ Voltage - 50hz 3 Phase with neutral		380/420V	380/420V	380/420V	380/420V	380/420V			
Compressor	Rated Load Amps	3.7	5.1	6.2	8	8.5			
	Locked Rotor Amps	31	55	55	67.1	66.1			
Outdoor Fan Motor	Full Load Amps	0.6	1.1	1.3	1.3	1.3			
Power Exhaust (1) 0.25 kW (0.33 HP)	Full Load Amps	1.3	1.3	1.3	1.3	1.3			
Indoor Blower Motor	kW	0.47	0.62	0.47	1.24	0.62	1.24	1.5	1.24
	Full Load Amps	1.4	1.9	1.4	2.6	1.9	2.6	3.6	2.6
² Maximum Overcurrent Protection	Unit Only	15	15	15	15	15	15	20	20
	With (1) 0.25 kW (0.33 HP) Power Exhaust	15	15	15	15	15	15	20	20
³ Minimum Circuit Ampacity	Unit Only	7	8	9	11	11	12	15	15
	With (1) 0.25 kW (0.33 HP) Power Exhaust	8	9	11	12	13	13	17	16

¹ Extremes of operating range are plus and minus 10% of line voltage.

² Heating/Air Conditioning/Refrigeration (HACR) type breaker or fuse.

³ Refer to local codes to determine wire, fuse and disconnect size requirements.

UNIT CLEARANCES

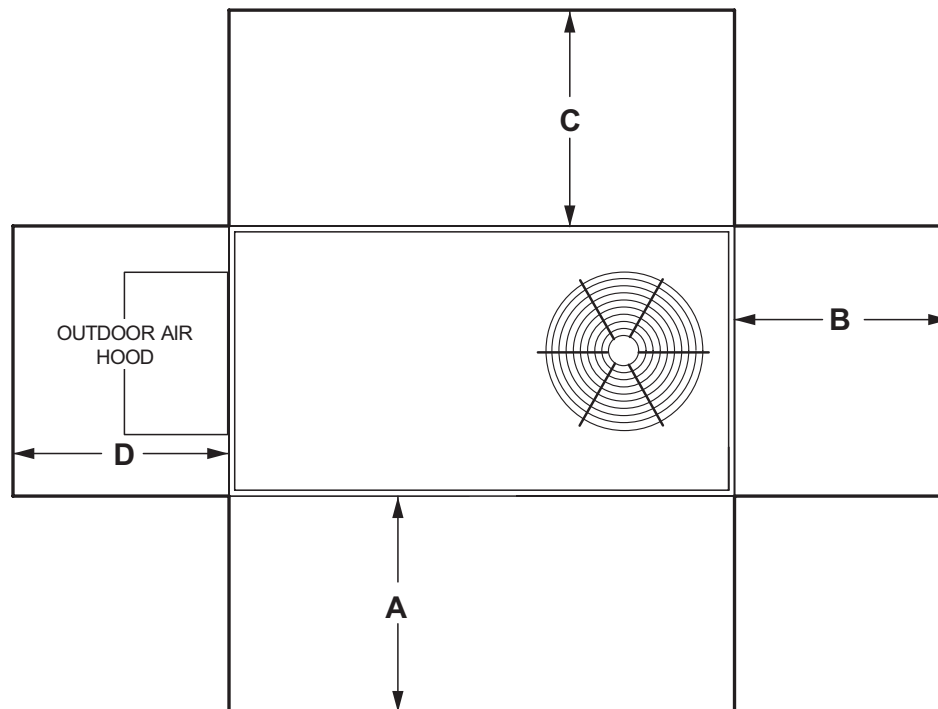

¹ Unit Clearance	A		B		C		D		Top Clearance
	mm	in.	mm	in.	mm	in.	mm	in.	
Service Clearance	1219	48	914	36	914	36	914	36	Unobstructed
Clearance to Combustibles	914	36	25	1	25	1	25	1	
Minimum Operation Clearance	914	36	914	36	914	36	914	36	

NOTE - Entire perimeter of unit base requires support when elevated above the mounting surface.

¹ **Service Clearance** - Required for removal of serviceable parts.

Clearance to Combustibles - Required clearance to combustible material.

Minimum Operation Clearance - Required clearance for proper unit operation.

WEIGHT DATA

Model Number	Outdoor Coil	Net		Shipping		Outdoor Coil	Net		Shipping	
		kg	lbs.	kg	lbs.		kg	lbs.	kg	lbs.
036 Base Unit	Environ™	249	549	277	610	Fin/Tube	257	568	285	629
036 Max. Unit	Environ™	337	743	365	804	Fin/Tube	346	762	373	823
048 Base Unit	Environ™	256	565	284	626	Fin/Tube	271	598	299	659
048 Max. Unit	Environ™	342	754	378	834	Fin/Tube	366	806	393	867
060 Base Unit	Environ™	292	643	319	704	Fin/Tube	311	685	338	746
060 Max. Unit	Environ™	395	871	423	932	Fin/Tube	414	913	442	974
072 Base Unit	Environ™	327	720	354	781	Fin/Tube	346	762	373	823
072 Max. Unit	Environ™	416	918	444	979	Fin/Tube	436	960	463	1021
074 Base Unit	Environ™	327	720	354	781	Fin/Tube	346	762	373	823
074 Max. Unit	Environ™	416	918	444	979	Fin/Tube	436	960	463	1021

OUTDOOR SOUND DATA

Unit Model No.	Octave Band Sound Power Levels dBA, re 10 ⁻¹² Watts Center Frequency - Hz							¹ Sound Rating Number (dBA)
	125	250	500	1000	2000	4000	8000	
036, 048	63	66	70	71	68	62	53	75
060, 072, 074	67	72	77	76	73	68	61	82

NOTE - The octave sound power data does not include tonal corrections.

¹ Sound Rating Number according to AHRI Standard 270-95 (includes pure tone penalty). The Sound Rating Number is the overall A-Weighted Sound Power Level, (Lwa), dB (100 Hz to 10,000 Hz).

OPTIONS / ACCESSORIES

Model No	Shipping Weight		
	kg	lbs.	
ECONOMIZER / OUTDOOR AIR / EXHAUST			
Economizer			
Economizer, Includes Outdoor Air Hood and Barometric Relief Dampers with Hood	59	131	
Outdoor Air Dampers			
Motorized	18	40	
Manual	14	30	
Power Exhaust			
Standard Static	17	35	
GAS HEAT			
Medium Heat (adder over standard heat)	4	8	
High Heat (adder over standard heat)	9	19	
ROOF CURBS			
Hybrid Roof Curbs, Downflow			
203 mm height	C1CURB70A-1	23	50
356 mm height	C1CURB71A-1	32	70
457 mm height	C1CURB72A-1	36	80
610 mm height	C1CURB73A-1	45	100
Adjustable Pitch Curb, Downflow			
356 mm height		51	113
CEILING DIFFUSERS			
Step-Down	RTD9-65S	36	80
	RTD11-95S	54	118
Flush	FD9-65S	36	80
	FD11-95S	54	118
Transitions	T1TRAN10AN1	10	22
	T1TRAN20N-1	10	21
HUMIDITROL® DEHUMIDIFICATION SYSTEM			
Humiditrol	036-048	12	27
	060-072	14	30
PACKAGING			
LTL Packaging (less than truck load)	036-048	27	60
	060-072	29	65

DIMENSIONS - UNIT

CORNER WEIGHTS

Model No.	CENTER OF GRAVITY											
	AA		BB		CC		DD		EE		FF	
	kg	lbs.	kg	lbs.	kg	lbs.	kg	lbs.	mm	in.	mm	in.
LGH036 Base Unit	45	98	54	119	87	192	72	158	978	38.5	457	18
LGH036 Max. Unit	62	137	70	155	113	250	100	221	1016	40	457	18
LGH048 Base Unit	47	104	57	126	92	202	76	167	978	38.5	457	18
LGH048 Max. Unit	66	145	74	164	120	264	106	233	1016	40	457	18
LGH060 Base Unit	54	118	65	144	105	232	87	191	978	38.5	457	18
LGH060 Max. Unit	75	164	84	186	136	299	120	264	1016	40	457	18
LGH072 Base Unit	60	132	73	160	117	258	96	212	978	38.5	457	18
LGH072 Max. Unit	78	173	89	195	143	314	126	278	1016	40	457	18
LGH074 Base Unit	60	132	73	160	117	258	96	212	978	38.5	457	18
LGH074 Max. Unit	78	173	89	195	143	314	126	278	1016	40	457	18

Base Unit - The unit with NO INTERNAL OPTIONS.

Max. Unit - The unit with ALL INTERNAL OPTIONS Installed. (Economizer, Standard Static Power Exhaust Fans, Controls, etc.). Does not include accessories external to unit or high static power exhaust.

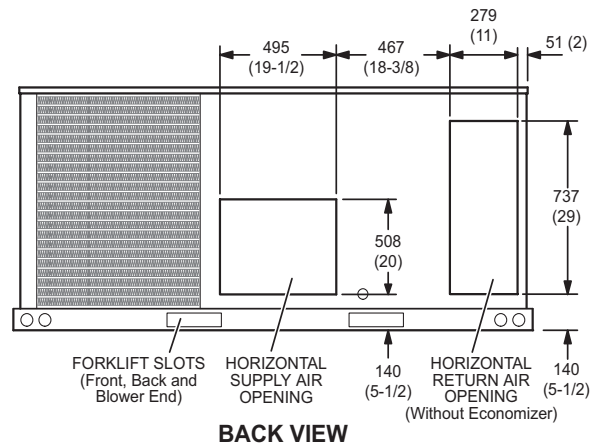
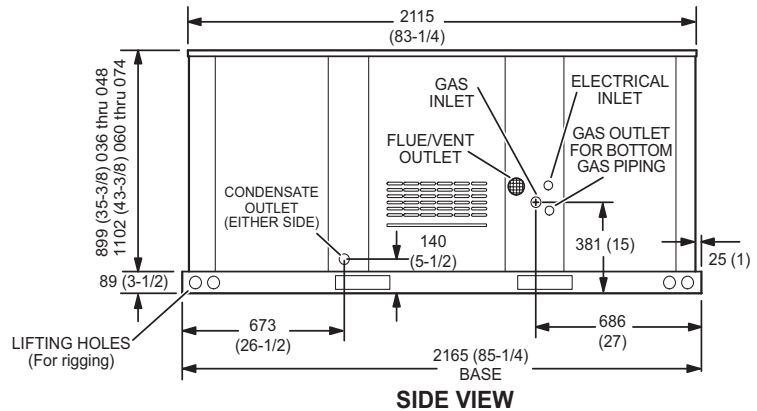
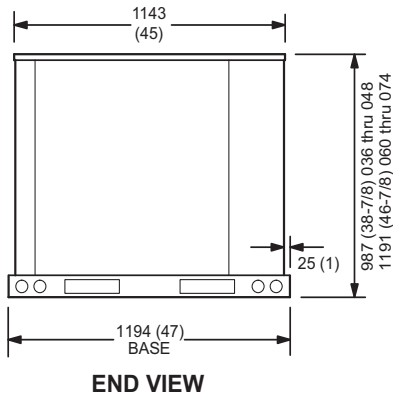
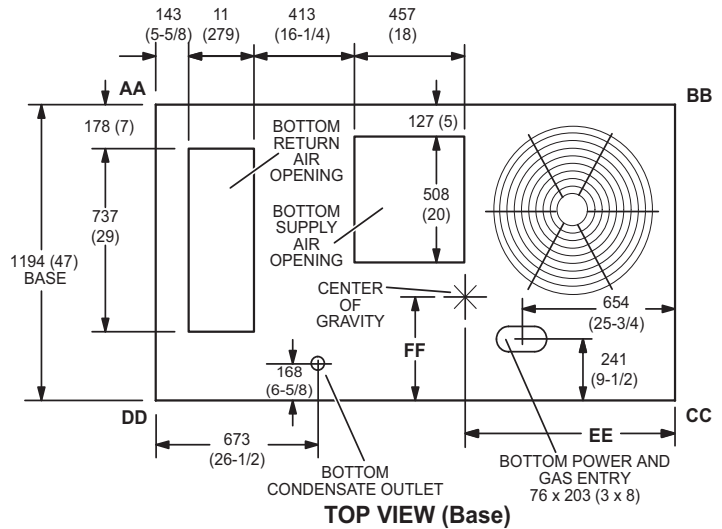

DIMENSIONS - ACCESSORIES

COMBINATION OUTDOOR AIR HOOD DETAIL FOR OPTIONAL ECONOMIZER AND BAROMETRIC RELIEF DAMPERS (Furnished With Economizer for Downflow Applications)

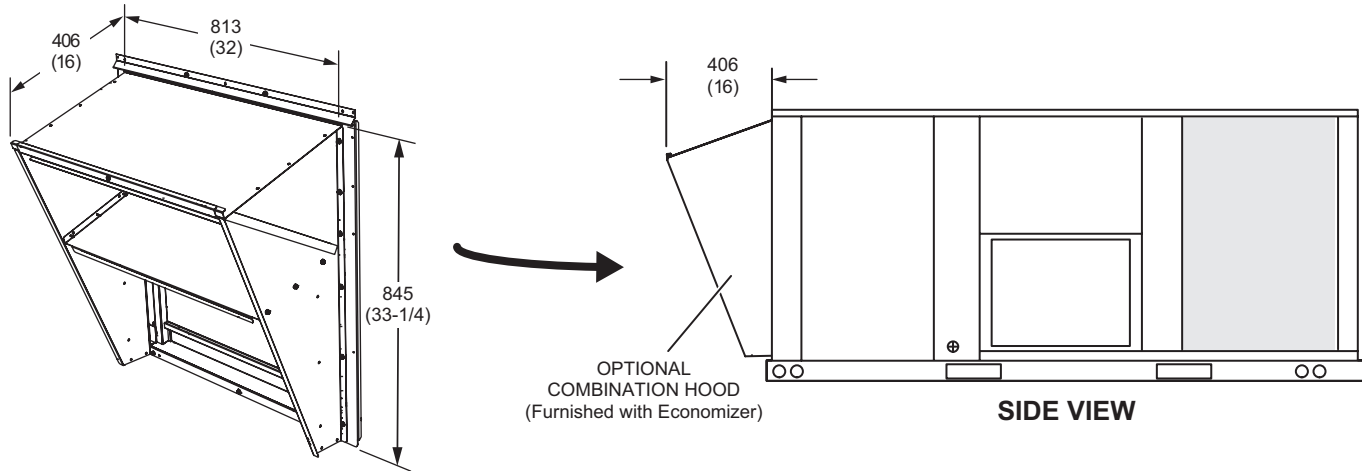

OUTDOOR AIR DAMPER HOOD DETAIL (Downflow or Horizontal Applications)

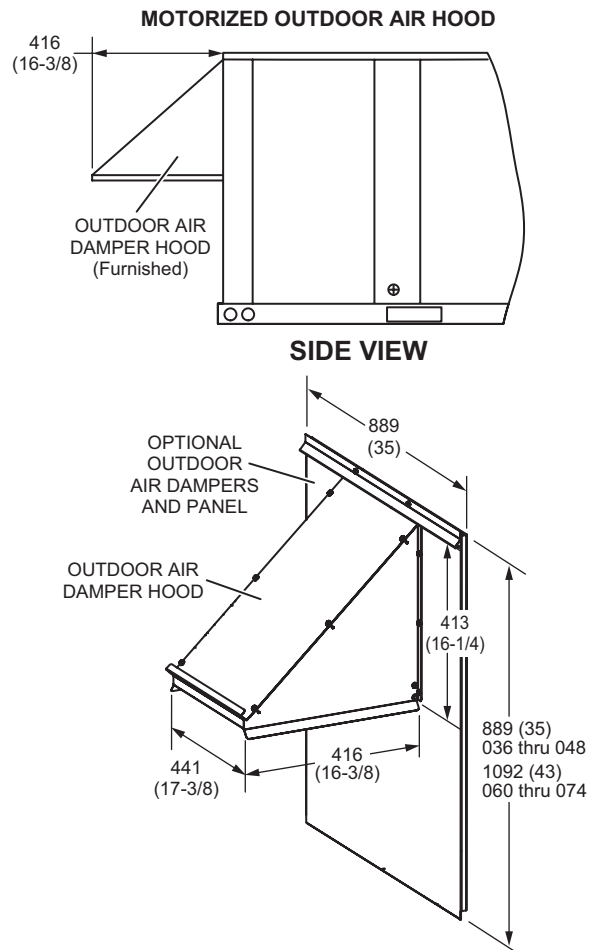
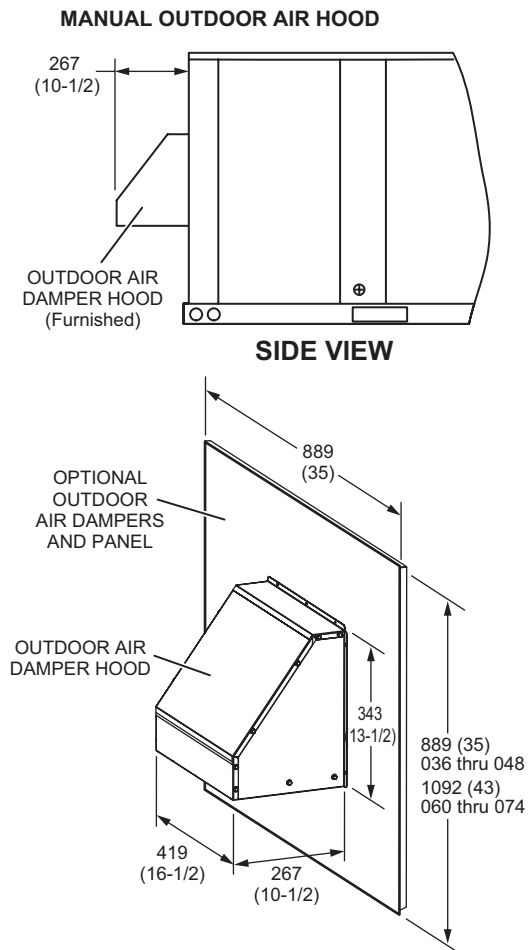

DIMENSIONS - ACCESSORIES

OUTDOOR AIR HOOD DETAIL WITH OPTIONAL ECONOMIZER AND OPTIONAL BAROMETRIC RELIEF DAMPERS WITH HOOD (Horizontal Application)

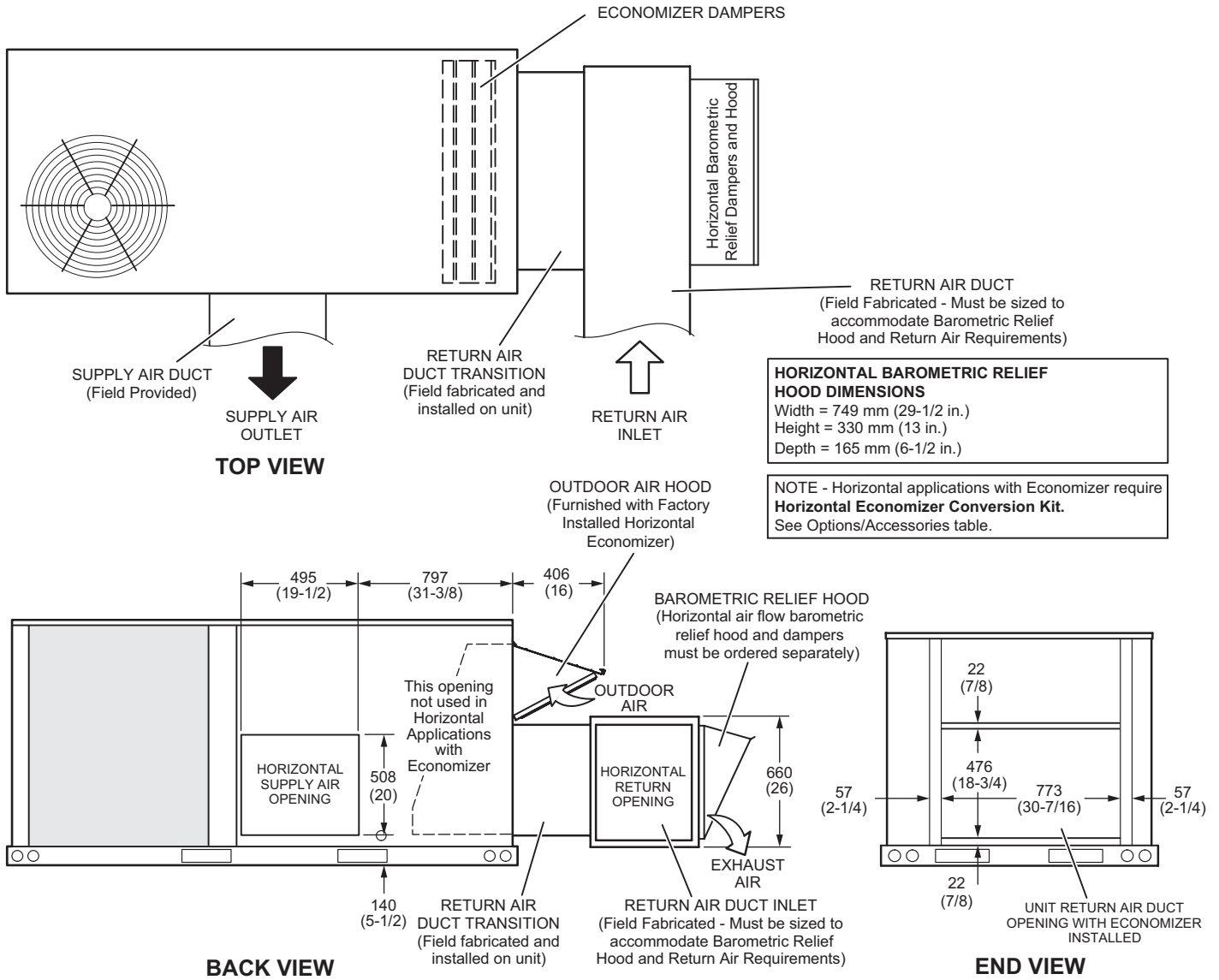

NOTE - Return Air Duct and Transition must be supported

DIMENSIONS - ACCESSORIES

HYBRID ROOF CURBS - DOUBLE DUCT OPENING

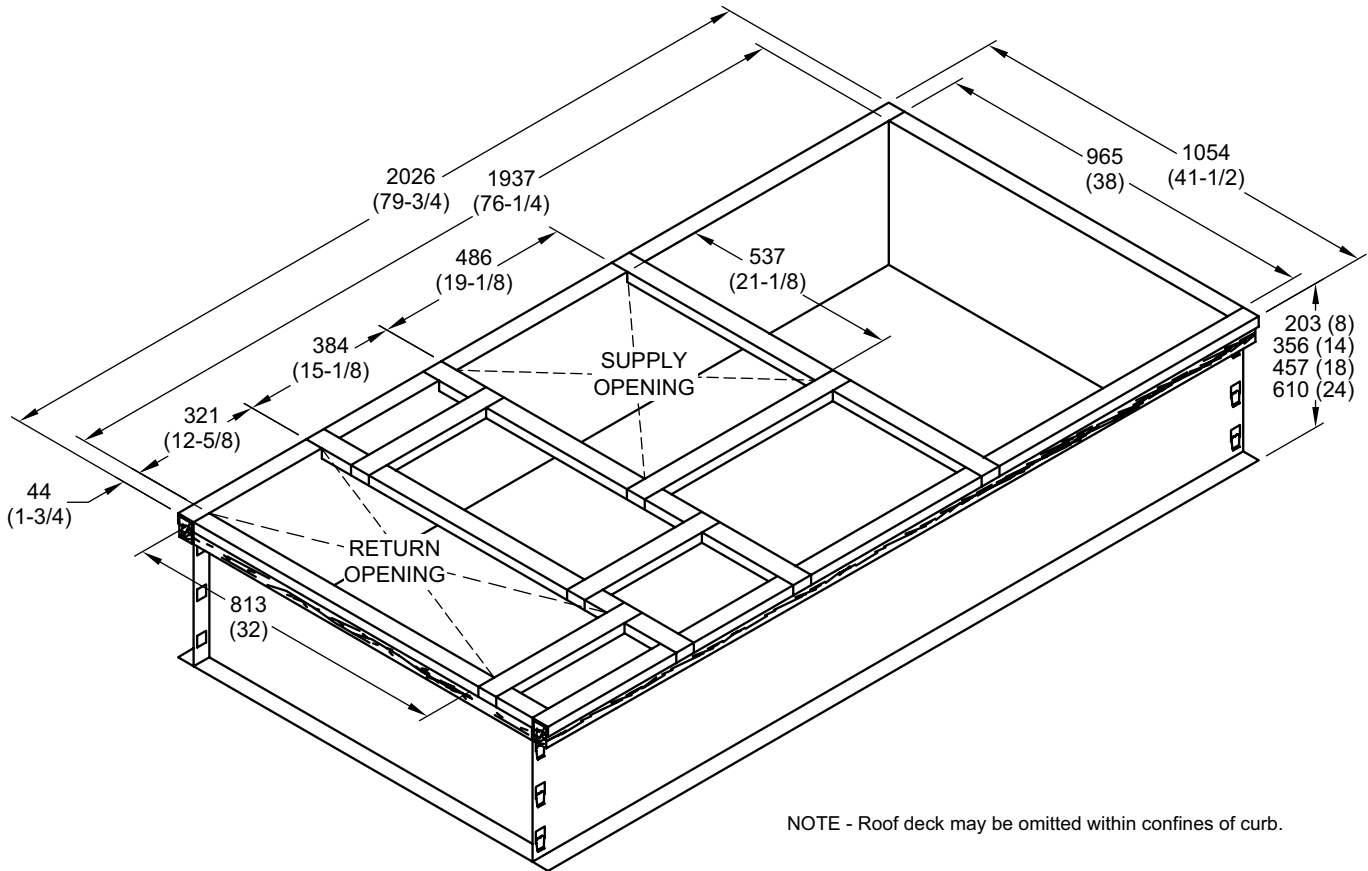

TYPICAL FLASHING DETAIL FOR ROOF CURB

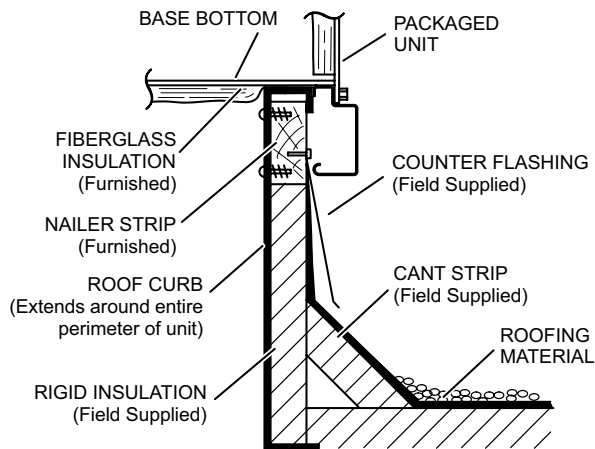

DETAIL ROOF CURB

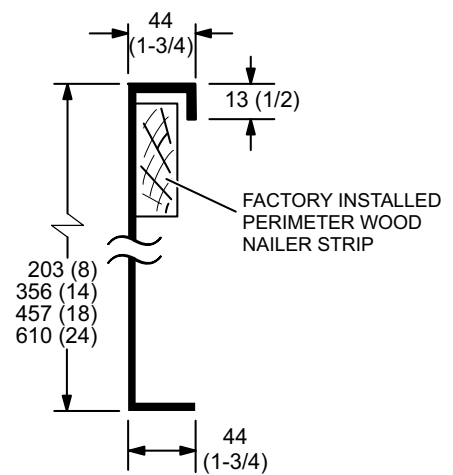

DIMENSIONS - ACCESSORIES

ADJUSTABLE PITCH CURBS - DOUBLE DUCT OPENING

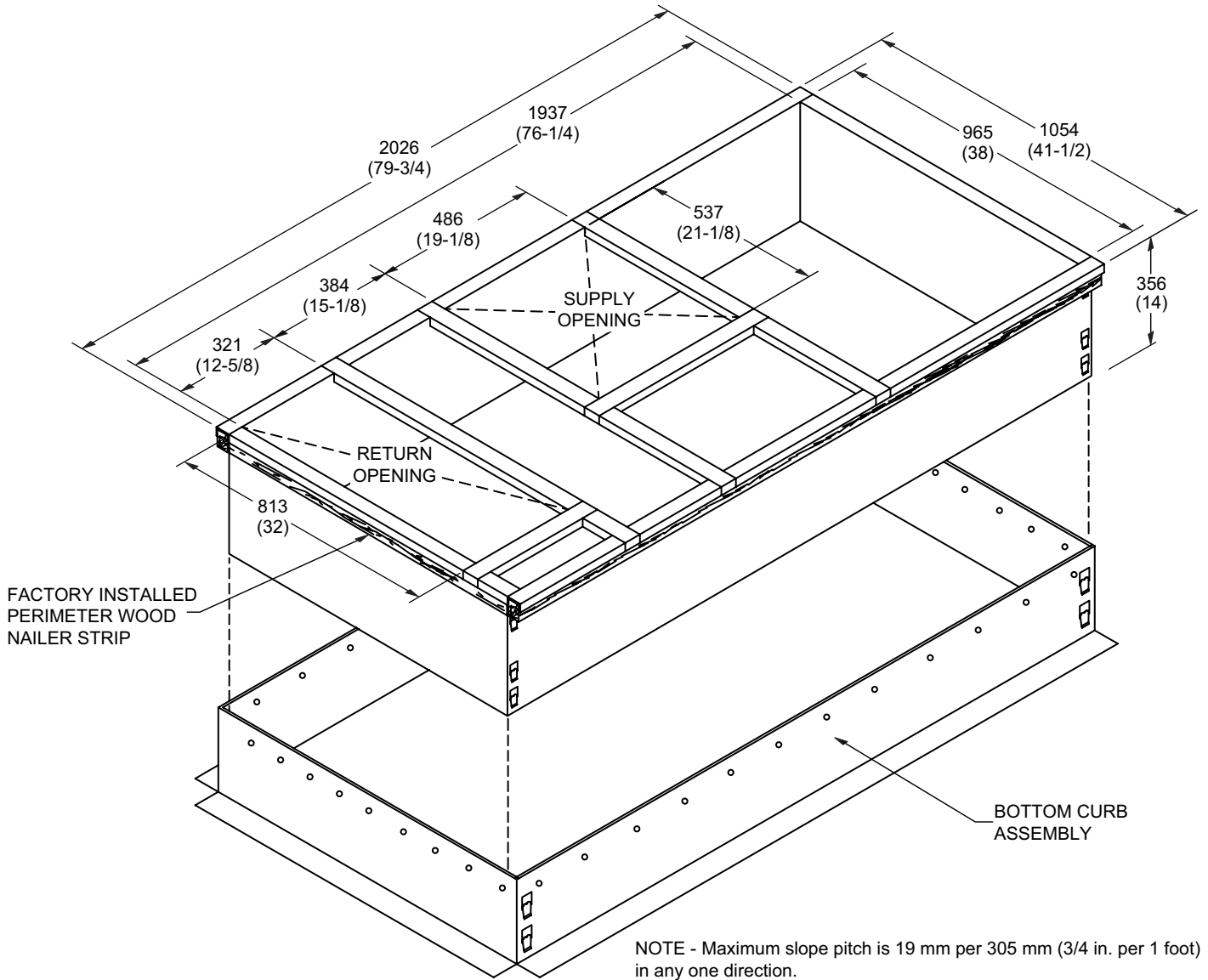

TYPICAL FLASHING DETAIL FOR ROOF CURB

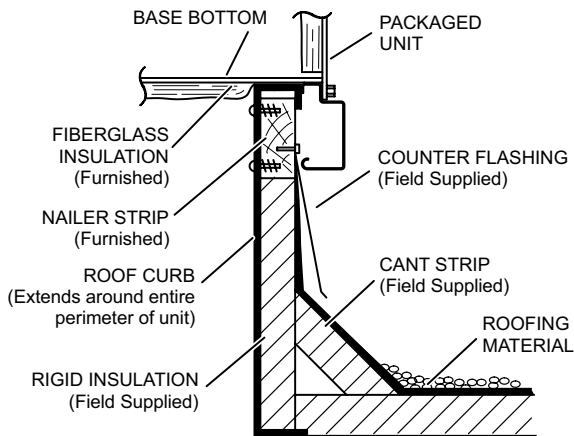

DETAIL ROOF CURB

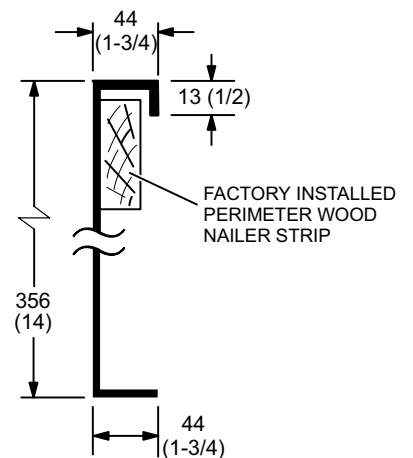

TRANSITIONS

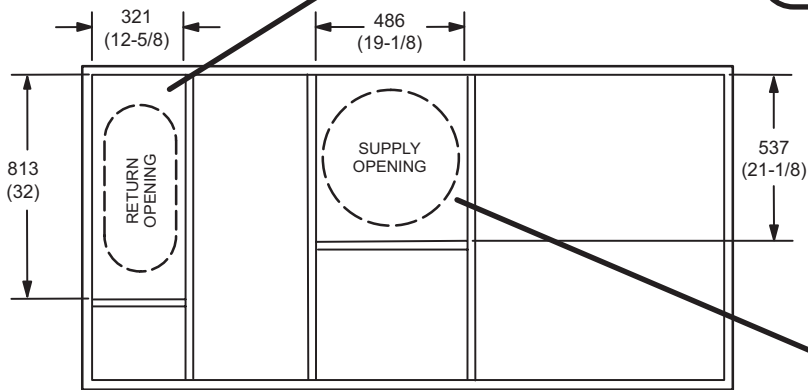
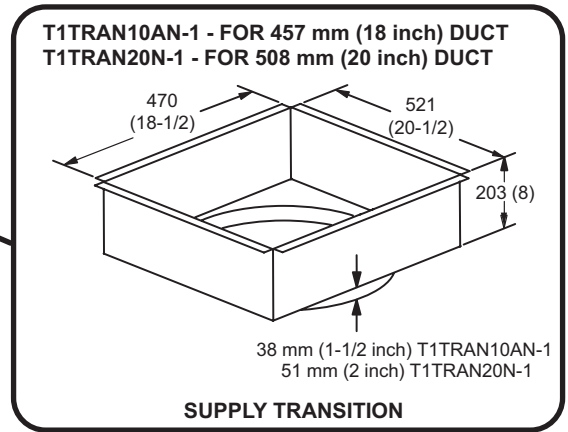
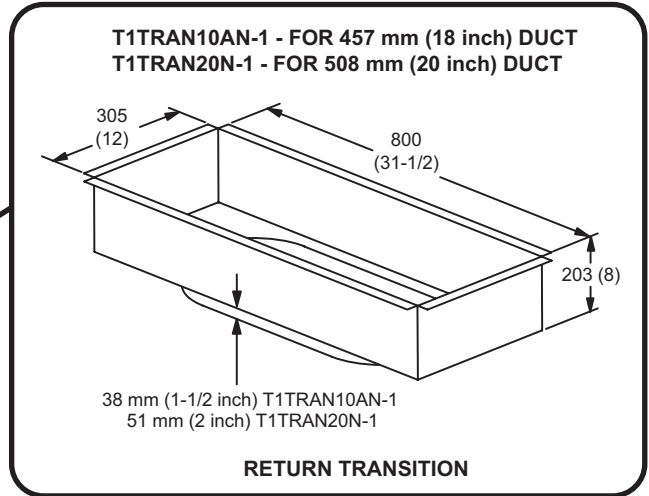

DIMENSIONS - ACCESSORIES

COMBINATION CEILING SUPPLY AND RETURN DIFFUSERS

STEP-DOWN CEILING DIFFUSER

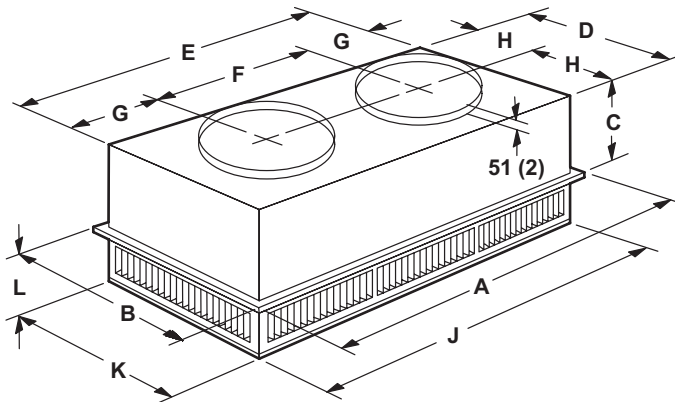

Model Number		RTD9-65S	RTD11-95S
A	mm	1159	1159
	in.	47-5/8	47-5/8
B	mm	600	752
	in.	23-5/8	29-5/8
C	mm	289	365
	in.	11-3/8	14-3/8
D	mm	546	699
	in.	21-1/2	27-1/2
E	mm	1156	1156
	in.	45-1/2	45-1/2
F	mm	572	572
	in.	22-1/2	22-1/2
G	mm	292	292
	in.	11-1/2	11-1/2
H	mm	273	349
	in.	10-3/4	13-3/4
J	mm	1156	1156
	in.	45-1/2	45-1/2
K	mm	546	699
	in.	21-1/2	27-1/2
L	mm	181	206
	in.	7-1/8	8-1/8
Duct Size	mm	457 round	508 round
	in.	18 round	20 round

FLUSH CEILING DIFFUSER

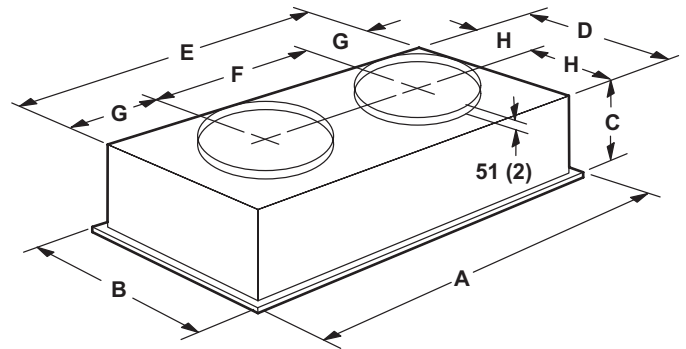

Model Number		FD9-65S	FD11-95S
A	mm	1159	1159
	in.	47-5/8	47-5/8
B	mm	600	752
	in.	23-5/8	29-5/8
C	mm	343	422
	in.	13-1/2	16-5/8
D	mm	533	686
	in.	21	27
E	mm	1143	1143
	in.	45	45
F	mm	572	572
	in.	22-1/2	22-1/2
G	mm	286	286
	in.	11-1/4	11-1/4
H	mm	267	343
	in.	10-1/2	13-1/2
Duct Size	mm	457 round	508 round
	in.	18 round	20 round

REVISIONS

Sections	Description of Change
Options/Accessories	Catalog numbers revised for: Blower Proving Switch Cold Weather Kits Discharge Air Temperature Switch Disconnects Economizers Float Switch Gravity Exhaust Dampers LPG Kits Power Exhaust Single Enthalpy Smoke Detectors



Visit us at www.lennox.com

For the latest technical information, www.lennoxcommercial.com

Contact us at 1-800-4-LENNOX

NOTE - Due to our ongoing commitment to quality, Specifications, Ratings and Dimensions subject to change without notice and without incurring liability. Improper installation, adjustment, alteration, service or maintenance can cause property damage or personal injury. Installation and service must be performed by a qualified installer and servicing agency.

©2021 Lennox Industries, Inc.