



**COMMERCIAL
 PRODUCT SPECIFICATIONS**

Bulletin No. 490153
 September 2021
 Supersedes July 2021



SMARTWIRE™ SYSTEM



88 to 105 kW (25 to 30 Tons)

Net Cooling Capacity - 74.4 to 93.2 kW (254 000 to 302 000 Btuh)

Gas Input Heat Capacity - 68.5 to 123 kW (234 000 to 420 000 Btuh)

MODEL NUMBER IDENTIFICATION

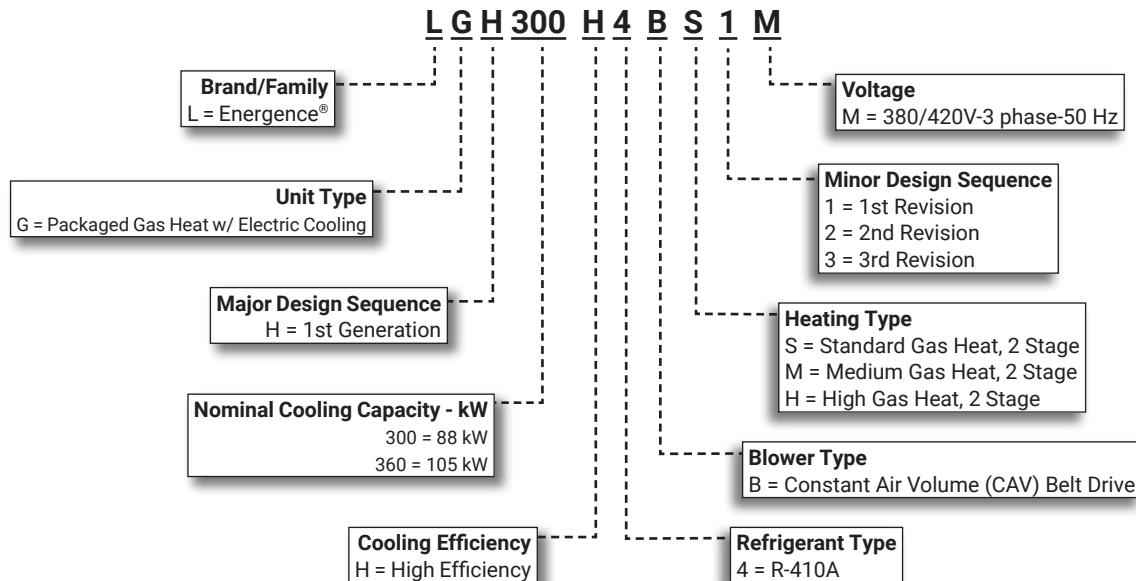

FEATURE HIGHLIGHTS

1. Aluminized Steel Inshot Burners
2. Scroll Compressors
3. Condenser Coil
4. Thermal Expansion Valves
5. Filters/Driers
6. Outdoor Coil Fan Motors
7. Construction
8. Hinged Access Panels
9. Blower
10. Air Filters
11. Unit Controller
12. Economizer
13. Downflow Barometric Relief Dampers
14. Standard Static Power Exhaust Fans

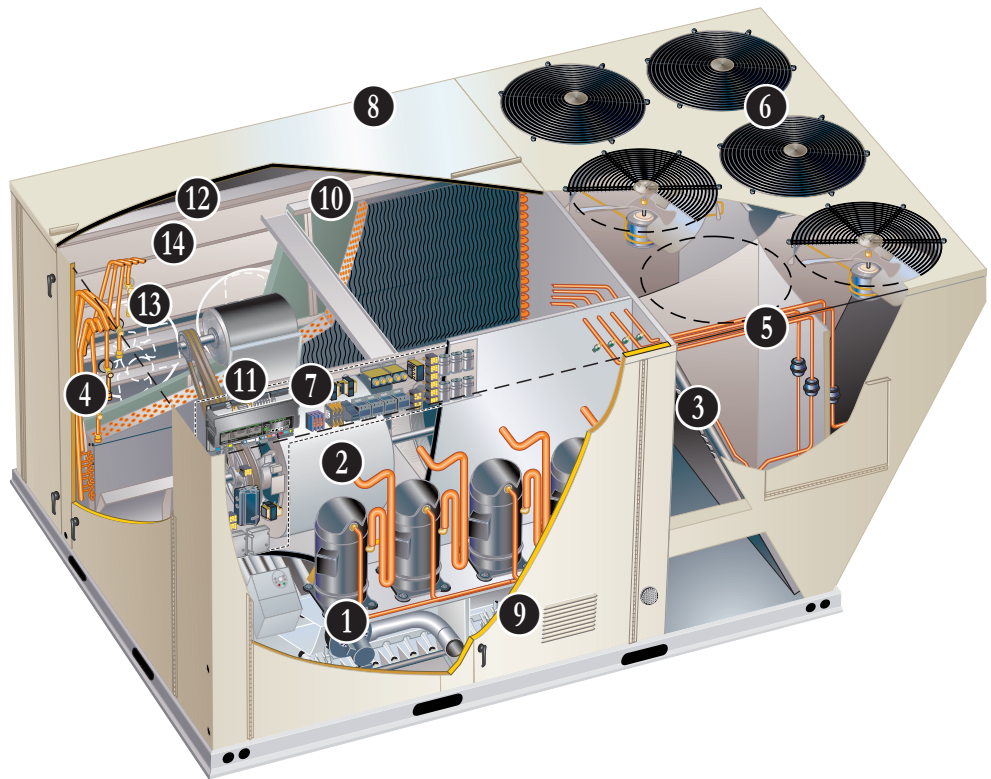

CONTENTS

Dimensions	26
- Unit	26
- Accessories	27
Blower Data	19
Electrical Data	23
Features And Benefits	3
High Altitude Derate	16
Model Number Identification	1
Optional Conventional Temperature Control Systems	10
Options / Accessories	12
Outdoor Sound Data	25
Ratings	17
Specifications	15
Specifications - Gas Heat	16
Unit Clearances	24
Weight Data	25
- Unit	25
- Options / Accessories	25

PERFORMANCE/QUALITY

- Components bonded for grounding to meet safety standards for servicing required by Underwriters Laboratories (UL) and the International Electrotechnical Commission (IEC)
- Cooling performance is rated at test conditions included in Air-Conditioning, Heating and Refrigeration (AHRI) Standard 340/360-2007 while operating at rated voltage and air volumes
- International Organization for Standardization (ISO) 9001 Registered Manufacturing Quality System

FEATURES AND BENEFITS

HEATING SYSTEM

Heat Exchanger

- Tubular construction, aluminized steel
- Life-cycle tested

NOTE - Optional Stainless Steel Heat Exchanger is required if mixed air temperature is below 7°C

1. Aluminized steel inshot burners
 - Direct spark ignition
 - Electronic flame sensor
 - Combustion air inducer
 - Redundant automatic dual stage gas valve with manual shut-off

Electronic Pilot Ignition

- Electronic spark igniter provides positive direct ignition of burners on each operating cycle
- Permits main gas valve to stay open only when the burners are proven to be lit
- If loss of flame occurs, gas valve closes, shutting off the gas to the burners
- LED indicates status and aids in troubleshooting
- Factory installed in the control section

Limit Controls

- Redundant limit controls with fixed temperature setting
- Protects heat exchanger and other components from overheating

Safety Switches

- Flame roll-out switch
- Flame sensor
- Combustion air inducer proving switch
- Protects system operation

Required Selections

Gas Input Choice - Order one:

- Standard Gas Heat, 2 Stage 49.5/68.5 kW
- Medium Gas Heat, 2 Stage 68.6/91.9 kW
- High Gas Heat, 2 Stage 91.4/123 kW

Options/Accessories

Factory Installed

Stainless Steel Heat Exchanger

- Required if mixed air temperature is below 7°C

Factory or Field Installed

Low Temperature Vestibule Heater

- Electric heater automatically controls minimum temperature in gas burner compartment when temperature is below -40°C

Field Installed

Combustion Air Intake Extensions

- Recommended for use with existing flue extension kits in areas where high snow areas can block intake air
- Order two kits

LPG/Propane Kits

- Conversion kit to field change over units from Natural Gas to LPG/Propane
- Order two kits

Vertical Vent Extension Kit

- Use to exhaust flue gases vertically above unit
- Required when unit vent is too close to fresh air intakes per building codes
- Also prevents ice formation on intake louvers
- Kit contains vent transition, vent tee, drain cap and installation hardware
- Order two kits

NOTE - Straight vent pipes (102 mm B-Vent) and caps are not furnished and must be field supplied. Refer to kit instructions for additional information.

FEATURES AND BENEFITS

COOLING SYSTEM

- Designed to maximize sensible and latent cooling performance at design conditions
- System can operate from -18°C to 52°C without any additional controls

R-410A Refrigerant

- Non-chlorine based
- Ozone friendly

2 Scroll Compressors

- Scroll compressors on all models for high performance, reliability and quiet operation
- Resiliently mounted on rubber grommets for quiet operation

Compressor Crankcase Heaters

- Protects against refrigerant migration that can occur during low ambient operation or during extended off cycles

3 Condenser Coil - Lennox' Environ™ Coil System

- Lightweight, all aluminum brazed fin construction
- Constructed of three components
 - A flat extrusion tube
 - Fins in-between the flat extrusion tube
 - Two refrigerant manifolds

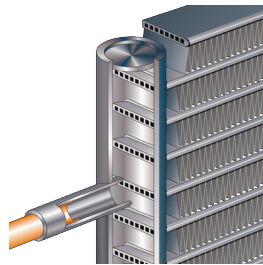

Environ™ Coil System Features:

- Improved heat transfer performance due to high primary surface area (flat tubes) versus secondary surface (fins)
- Smaller internal volume (reduced refrigerant charge)
- High durability
- All aluminum construction
- Fewer brazed joints
- Compact design
- Reduced unit weight
- Easy maintenance/cleaning
- Face split design
- Mounting brackets with rubber inserts
- Angled cabinet design protects coil from damage

Evaporator Coil

- Copper tube construction
- Enhanced rippled-edge aluminum fins
- Flared shoulder tubing connections
- Silver soldered construction
- Factory leak tested
- Cross row circuiting with rifled tubing

NOTE - Constant air volume (CAV) and MSAV® (Multi-Stage Air Volume) models have face-split evaporator coils designed to keep condensate water off of an inactive part of the coil so the condensate will not re-enter the air stream. Variable air volume (VAV) models have row-split, intertwined evaporator coils.

4 Thermal Expansion Valves

- Ensures optimal performance throughout the application range
- Removable element head

5 Filter/Driers

- High capacity filter/drier protects the system from dirt and moisture

High Pressure Switches

Protects the compressor from overload conditions such as dirty condenser coils, blocked refrigerant flow, or loss of outdoor fan operation

Low Pressure Switches

- Protects the compressors from low pressure conditions such as low refrigerant charge, or low/no airflow

Condensate Drain Pan

- Plastic, sloped drain pan
- Side drain connections

NOTE - Stainless steel drain pan available as a factory installed option.

Freezestats

- Protects the evaporator coil from damaging ice build-up due to conditions such as low/no airflow, or low refrigerant charge

6 Outdoor Coil Fan Motors

- Thermal overload protected
- Totally enclosed
- Permanently lubricated ball bearings
- Shaft up
- Wire basket mount

Outdoor Coil Fans

- Polyvinyl chloride (PVC) coated fan guard furnished

Required Selections

Cooling Capacity

- Specify nominal cooling capacity

Options/Accessories

Factory Installed

Discharge Air Temperature Sensor

- Sensor sends information to the unit controller to cycle up to 2 stages of heating or 4 stages of cooling to maintain the discharge air setpoints for heating or cooling
- Optional for units with single zone or bypass zoning control

NOTE - Sensor is shipped with the unit for remote field installation in the supply duct.

Factory or Field Installed

Condensate Drain Trap

- Available in copper or Polyvinyl chloride (PVC)
- Field installed only, may be factory ordered to ship with unit

FEATURES AND BENEFITS

COOLING SYSTEM

Drain Pan Overflow Switch

- Monitors condensate level in drain pan
- Shuts down unit if drain becomes clogged

Stainless Steel Drain Pan

- Non-corrosive drain pan

BLOWER

- 7** A wide selection of supply air blower options are available to meet a variety of airflow requirements

Motor

- Overload protected
- Ball bearings
- Belt drive motors are offered on all models and are available in several different sizes to maximize air performance

Supply Air Blower

- Forward curved blades
- Double inlet
- Blower wheel is statically and dynamically balanced
- Adjustable pulley for speed change
- Blower assembly slides out of unit for servicing
- Grease fittings furnished

Required Selections

- Specify motor output and drive kit number when base unit is ordered, see Drive Kit Specifications tables.
- Order one drive kit, see Drive Kit Specifications Table

Options/Accessories

Factory Installed

Blower Belt Auto-Tensioner

- Provides proper tension to belt drive blower belt without the need for regular adjustments
- Maintains airflow and proper performance

Field Installed

Supply Static Limit Switch

- Manual reset switch for supply static high pressure limit
- Prevents exceeding pressure limit in supply air duct
- Optional Mounting Kit includes tubing and adaptors

CABINET

8 Construction

- Heavy-gauge steel panels
- Full perimeter heavy-gauge galvanized steel base rail
- Base rails have rigging holes
- Three sides of the base rail have forklift slots
- Raised edges around duct and power entry openings in the bottom of the unit for water protection

Airflow Choice

- Units are shipped in downflow (vertical) return air flow configuration

NOTE - Units can be field converted to horizontal air flow with optional Horizontal Return Air Panel Kit and Horizontal Roof Curb.

Power/Gas Entry

- Electrical and gas lines can be brought through the unit base or through horizontal access knock-outs

Exterior Panels

- Constructed of heavy-gauge, galvanized steel
- Two-layer enamel paint finish

Insulation

- Fully insulated with non-hygroscopic fiberglass insulation (conditioned areas)
- Unit base is fully insulated
- Base insulation serves as an air seal to the roof curb, eliminating the need to add a seal during installation

9 Hinged Access Panels

- Filter section
- Blower section
- Heating section
- Compressor/controls section
- Panel seals and quarter-turn latching handles provide a tight air and water seal

FEATURES AND BENEFITS

CABINET (continued)

Options/Accessories

Factory Installed

Corrosion Protection

- Completely flexible immersed coating
- Electrodeposited dry film process
- AST ElectroFin E-Coat
- Meets Mil Spec MIL-P-53084, ASTM B117 Standard Method Salt Spray Testing
- Indoor Corrosion Protection:
 - Coated coil
 - Painted blower housing
 - Painted base
- Outdoor Corrosion Protection:
 - Coated coil
 - Painted outdoor base

Field Installed

Combination Coil/Hail Guards

- Heavy gauge steel frame
- Painted to match cabinet
- Expanded metal mesh protects outdoor coil

Grille Guards

- Protects the space between outdoor coils and main cabinet

Horizontal Return Air Panel Kit

- Required for horizontal applications with Horizontal Roof Curb
- Contains panel with return air opening for field replacement of existing unit panel and panel to cover bottom return air opening in unit
- See dimension drawings

ELECTRICAL

- All units include terminal block and fuse block in power entry junction box for single power entry application

SmartWire™ System

- Keyed and color-coded to prevent miswiring
- Wire coloring scheme is standardized across all models
- Each connection is intuitively labeled to make troubleshooting and servicing quick and easy

Required Selections

Voltage Choice

- Specify when ordering base unit

INDOOR AIR QUALITY

10 Air Filters

- Disposable 51 mm filters furnished as standard

Options/Accessories

Factory or Field Installed

Healthy Climate® High Efficiency Air Filters

- Disposable MERV 8 or MERV 13 (Minimum Efficiency Reporting Value based on ASHRAE 52.2) efficiency 51 mm pleated filters

Replacement Filter Media Kit With Frame

- Replaces existing pleated filter media
- Includes washable metal mesh screen and metal frame with clip for holding replaceable non-pleated filter

Field Installed

Indoor Air Quality (CO₂) Sensors

- Monitors CO₂ levels, reports to the Prodigy® 2.0 Unit Controller, which adjusts economizer dampers as needed

CONTROL SYSTEM

PRODIGY CONTROL SYSTEM



11 The Prodigy® Unit Controller is a microprocessor-based control board that provides flexible control of all unit functions.

Features:

- LCD Display
- Easy to read menu (4 lines x 20 character display)
- Buttons for menu navigation during setup and diagnostic
- Menu navigation LEDs for Data, Setup, Service, Settings
- Main Menu and Help Buttons for quick navigation to home screen and built-in help functions
- Scroll, Value Adjustment Select and Save Buttons
- Setup menu insures proper installation and simplified setup of the rooftop unit
- Profile setup copies key settings between units with the same configuration to reduce setup time
- USB port allows a technician to download and transfer unit information to help verify service was performed
- USB software updates on the Prodigy® Control System enhance functionality without the need to change components
- Unit Controller Software
- Unit self-test verifies individual critical component and system performance
- Economizer test function assures economizer is operating correctly
- Time Clock with Run-Time Information

Built-In Functions Include:

- Adjustable Blower On/Off Delay
- Built-in Control Parameter Defaults
- Compressor Time-Off Delay
- DDC Compatible
- Dirty Filter Switch Input
- Discharge Air Temperature Control
- Display/Sensor Readout
- Economizer Control Options (See Economizer / Exhaust Air / Outdoor Air sections)
- Fresh Air Tempering
- Over 100 diagnostic and status messages in English
- Exhaust Fan Control Modes for fresh air damper position
- Permanent Diagnostic Code Storage
- Field Adjustable Control Parameters (Over 200 settings)
- Indoor Air Quality Input (Demand Control Ventilation)
- Low Ambient Controls for cooling operation down to 0°F

- Gas Valve Time Delay Between First and Second Stage
- Minimum Compressor Run Time
- Network Capable (Can be daisy chained to other units or controls)
- Night Setback Mode
- Return Air Temperature Limit Control
- Safety Switch Input allows Controller to respond to a external safety switch trip
- Service Relay Output
- Smoke Alarm Mode has four choices (unit off, positive pressure, negative pressure, purge)
- Up to 2 heat/2 cool (standard Prodigy unit controller thermostat input)
- Up to 3 cool with additional relay
- Up to 4 cool with room sensor or network operation
- “Strike Three” Protection
- Gas Reheat Control allows simultaneous heating and cooling operation for humidity control of process air applications such as supermarkets
- On Demand Dehumidification monitors and controls condenser hot gas reheat operation with Humiditrol® dehumidification option
- Thermostat Bounce Delay
- Warm Up Mode Delay
- LED Indicators
- PC Interface connects the Prodigy® unit controller to a PC with the Lennox Unit Controller Software
- Room Sensor Operation controls temperature

NOTE - Prodigy® Control System features shown vary with the type of rooftop in which the unit control is installed.

ECONOMIZER

- 12 Economizer operation is set and controlled by the Prodigy® unit controller
- Simple plug-in connections from economizer to unit controller for easy installation

NOTE - Optional sensors may be used instead of unit sensors to determine whether outdoor air is suitable for free cooling. See Options/Accessories table.

High Performance Economizer Features

- Gear-driven action
- High torque 24-volt fully-modulating spring return damper motor
- Return air and outdoor air dampers
- Plug-in connections to unit
- Stainless steel bearings
- Enhanced neoprene blade edge seals
- Flexible stainless steel jamb seals
- Low leakage dampers are Air Movement and Control Association International (AMCA) Class 1A Certified - Maximum 3 CFM per sq. ft. leakage at 1 in. w.g.

Differential Sensible Control

- Factory setting
- Uses outdoor air and return air sensors that are furnished with the unit
- The Prodigy® unit controller compares outdoor air temperature with return air
- When the outdoor air is below the configured setpoint and cooler than return air, the controller activates the economizer

NOTE - Differential Sensible Control can be configured in the field to provide Offset Differential Sensible Control or Single Sensible Control.

NOTE - In Offset Differential Sensible Control mode, the economizer is enabled if the temperature differential (offset) between outdoor air and return air reaches the configured setpoint. In Single Sensible Control mode, the economizer is enabled when outdoor air temperature falls below the configured setpoint.

NOTE: The Free Cooling default setting for outdoor air temperature sensor is 13°C.

Global Control

- The unit controller communicates with a DDC system with one global sensor (enthalpy or sensible)
- Determines whether outside air is suitable for free cooling on all units connected to the control system
- Sensor must be field provided

Factory or Field Installed

Single Enthalpy Temperature Control

- Outdoor air enthalpy sensor enables Economizer if the outdoor enthalpy is less than the setpoint of the control

Differential Enthalpy Control

- Order two Single Enthalpy Controls
- One is field installed in the return air section
- One is installed in the outdoor air section
- Allows the economizer control to select between outdoor air or return air, whichever has lower enthalpy

EXHAUST

Factory or Field Installed

13 Downflow Barometric Relief Dampers

- Allow relief of excess air
- Aluminum blade dampers prevent blow back and outdoor air infiltration during off cycle
- Exhaust hood is factory installed when dampers are factory installed with economizer
- Exhaust hood is furnished with dampers when ordered for field installation
- Bird screen furnished

14 Standard Static Power Exhaust Fans

- Three, 0.25 kW motors
- 508 mm, five blade propeller-type fans
- Total power input of 1125 W
- Total air volume of 6040 L/s at 0 Pa
- Motor is inherently protected
- Totally enclosed
- Installs internal to unit for downflow applications only with economizer option
- Provides exhaust air pressure relief
- Interlocked to run when return air dampers are closed and supply air blower is operating
- Fan runs when outdoor air dampers are 50% open (adjustable)
- Motor is overload protected
- Steel cabinet and hood painted to match unit

NOTE - Requires optional Downflow Economizer Barometric Relief Dampers. See Standard Static Power Exhaust Blower Tables.

Horizontal Barometric Relief Dampers

- For use when unit is configured for horizontal applications requiring an economizer
- Allows relief of excess air
- Aluminum blade dampers prevent blow back and outdoor air infiltration during off cycle
- Field installed in return air duct
- Bird screen and hood furnished

NOTE - Horizontal Economizer Conversion kit is available for field installation.

OPTIONS / ACCESSORIES

OUTDOOR AIR

Factory or Field Installed

Outdoor Air Damper - Downflow or Horizontal With Air Hood

- Linked mechanical dampers
- 0 to 25% (fixed) outdoor air adjustable
- Installs in unit. Includes outdoor air hood
- Automatic model features fully modulating spring return damper motor with plug-in connection
- Manual model features parallel blade, gear-driven dampers with adjustable fixed position

NOTE - Minimum mixed air temperature in heating mode is -1°C. Maximum mixed air temperature in cooling mode is 32°C.

ROOF CURBS

- Nailer strip furnished
- Mates to unit
- US National Roofing Contractors Approved
- Shipped knocked down

Downflow

Hybrid Roof Curbs

- Interlocking tabs to fasten corners together
- No tools required
- Curb can also be fastened together with furnished hardware
- Available in 356, 457, and 610 mm heights
- See Options/Accessories table

Horizontal

- Converts unit from downflow to horizontal (side) air flow
- Return air is on unit, supply air is on curb, see dimension drawings
- Requires Horizontal Return Air Panel Kit
- Available in 940 mm and 1041 mm heights
- Optional Insulation Kit is available to help prevent sweating

CEILING DIFFUSERS

Ceiling Diffusers (Flush or Step-Down)

- Aluminum grilles
- Large center grille
- Insulated diffuser box with flanges
- Hanging rings furnished
- Interior transition (even air flow)
- Internally sealed (prevents recirculation)
- Adapts to T-bar ceiling grids or plaster ceilings

Transitions (Supply and Return)

- Used with diffusers
- Installs in roof curb
- Galvanized steel construction
- Flanges furnished for duct connection to diffusers
- Fully insulated

OPTIONAL CONVENTIONAL TEMPERATURE CONTROL SYSTEMS

ComfortSense® 8500 Commercial 7-Day Programmable Thermostat

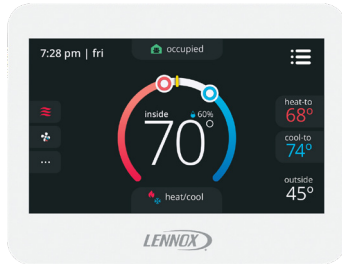

- Fully Communicating Sensor
- Full Color Touchscreen Interface
- Variable Speed System Control (On Compatible Units)
- Up To 4 Heat / 4 Cool
- Built-In Sensors For Temperature, Humidity And Optional CO₂
- Remote Sensor Options For Occupancy, Temperature
- BACnet Capable Options
- 5-2 or 7-Day Scheduling
- Smooth Setback Recovery
- Heat/Cool Auto-Changeover
- Four-Wire Installation
- FDD, ASHRAE, IECC Compliant

ComfortSense® 7500 Commercial 7-Day Programmable Thermostat



- Premium Universal Thermostat
- Full Color Touchscreen Interface
- Up To 4 Heat / 4 Cool
- Built-In Sensors For Temperature and Humidity
- Remote Sensors Options For Temperature, Discharge Air, Outdoor Air
- 5-2 or 7-Day Scheduling
- Smooth Setback Recovery
- Heat/Cool Auto-Changeover
- FDD, ASHRAE, IECC Compliant

ComfortSense® 3000 Commercial 5-2 Day Programmable Thermostat



- Conventional Multi-Stage Thermostat
- Intuitive Display
- Push-Button Operation
- Up To 2 Heat / 2 Cool
- Built-In Temperature Sensor
- Remote Temperature Sensing
- Up to 5-2 Day Scheduling
- Smooth Setback Recovery
- Heat/Cool Auto-changeover

Wired Room Sensor (LCS-5030)



- Simple Push-Button Override
- Variable Speed System Control (On Compatible Units)
- Up To 4 Heat / 4 Cool
- Built-In Temperature and Humidity Sensors
- AA Battery / 24VAC Powered
- SBUS Wired Operation
- Automatic Sensor Averaging
- Locking Hex Screw

OPTIONAL CONVENTIONAL TEMPERATURE CONTROL SYSTEMS

Description	Catalog No.
ComfortSense® 8500 Commercial 7 Day Programmable Thermostat	
CS8500 7-Day Thermostat	No CO ₂ Sensing 17G75
	With CO ₂ Sensing 17G76
Sensors/Accessories	¹ Remote non-adjustable wall-mount 10k 47W37
	¹ Remote non-adjustable wall-mount 11k 94L61
Sysbus Network Cable (Yellow) for ComfortSense 8500 and LCS-5030 Wired Room Sensor	
Twisted pair 100% shielded communication cable, Red and Black	500 ft. box 27M19
22 AWG, yellow jacket, rated at 75°C, 300V, Plenum rated	1000 ft. box 94L63
Insulation - Low smoke PVC, NEC, CMP	2500 ft. roll 68M25
ComfortSense® 7500 Commercial 7-Day Programmable Thermostat	
CS7500 7-Day Thermostat	17G74
Sensors/Accessories	² Remote non-adjustable wall-mount 20k 47W36
	² Remote non-adjustable wall-mount 10k 47W37
	Remote non-adjustable discharge air (duct mount) 19L22
	Outdoor temperature sensor X2658
ComfortSense® 3000 Commercial 5-2 Day Programmable Thermostat	
CS3000 5-2 Day Thermostat	11Y05
Sensors/Accessories	Remote non-adjustable wall mount 10k averaging 47W37
	Thermostat wall mounting plate X2659
ComfortSense® Non-Programmable Thermostat	
CS3000 Non-Programmable Thermostat	51M32
Universal Thermostat Guard with Lock (clear)	
	Inside Dimensions (H x W) 5 7/8 x 8 3/8 in. 39P21
Wired Room Sensor	
LCS-5030 Wired Room Sensor	21L07

¹ Up to nine of the same type remote temperature sensors can be connected in parallel.

² Remote wall-mount sensors can be applied in any of the following combinations:
 One Sensor - (1) 47W36, Two Sensors - (2) 47W37, Three Sensors - (2) 47W36 and (1) 47W37
 Four Sensors - (4) 47W36, Five Sensors - (3) 47W36 and (2) 47W37

OPTIONS / ACCESSORIES

Item Description	Catalog Number	Unit Model No		
		300	360	
GAS HEAT				
Combustion Air Intake Extensions (Order 2 Kits)	89L97	X	X	
Gas Heat Input	Standard - 49.5/68.5 kW input	Factory	O	O
	Medium - 68.6/91.9 kW input	Factory	O	O
	High - 91.4/123 kW input	Factory	O	O
Low Temperature Vesibule Heater	380/420V-3ph 58W29	OX	OX	
LPG/Propane Conversion Kits (Order 2 Kits)	Standard Heat 14N28	X	X	
	Medium Heat 14N29	X	X	
	High Heat 14N30	X	X	
Stainless Steel Heat Exchanger	Factory	O	O	
Vertical Vent Extension	42W16	X	X	
COOLING SYSTEM				
Condensate Drain Trap	Polyvinyl chloride (PVC) 22H54	OX	OX	
	Copper 76W27	OX	OX	
Corrosion Protection	Factory	O	O	
Drain Pan Overflow Switch	21Z07	OX	OX	
Efficiency	High	Factory	O	O
Refrigerant Type	R-410A	Factory	O	O
Plastic Condensate Drain Pan	Factory	O	O	
Stainless Steel Condensate Drain Pan	83W42	OX	OX	
BLOWER - SUPPLY AIR				
Motors	Belt Drive - 3.7 kW	Factory	O	O
	Belt Drive - 5.6 kW	Factory	O	O
	Belt Drive - 7.5 kW	Factory	O	O
Drive Kits See Blower Data Tables for usage and selection	Kit #1 615-745 rev/min	Factory	O	O
	Kit #2 725-870 rev/min	Factory	O	O
	Kit #3 595-730 rev/min	Factory	O	O
	Kit #4 640-805 rev/min	Factory	O	O
	Kit #5 550-675 rev/min	Factory	O	O
	Kit #6 640-805 rev/min	Factory	O	O
	Kit #7 475-600 rev/min	Factory	O	O
	Kit #8 400-525 rev/min	Factory	O	O
	Blower Belt Auto-Tensioner	Factory	O	O
CABINET				
Combination Coil/Hail Guards	13T16	X	X	
Grille Guards	86K30	X	X	
Horizontal Return Air Panel Kit	38K48	X	X	

NOTE - Catalog and model numbers shown are for ordering field installed accessories.

OX - Configure To Order (Factory Installed) or Field Installed

O = Configure To Order (Factory Installed)

X = Field Installed

OPTIONS / ACCESSORIES

Item Description	Catalog Number	Unit Model No		
		300	360	
CONTROLS				
Blower Proving Switch	21Z10	OX	OX	
	Prodigy® Control System - BACnet® Module	59W51	OX	OX
	Prodigy® Control System - LonTalk® Module	54W27	OX	OX
	Novar® LSE	Factory	O	O
Dirty Filter Switch	53W68	OX	OX	
Discharge Air Temperature Sensor	Factory	O	O	
Fresh Air Tempering	21Z08	OX	OX	
Smoke Detector - Supply or Return (Power board and one sensor)	22H56	OX	OX	
Smoke Detector - Supply and Return (Power board and two sensors)	22H57	OX	OX	
Supply Static Limit Switch	79M80	X	X	
Supply Static Limit Switch - Mounting Kit	79M81	X	X	
Supply Static Transducer	78M19	X	X	
INDOOR AIR QUALITY				
Air Filters				
Healthy Climate High Efficiency Air Filters 508 x 508 x 51 mm - order 12 per unit	MERV 8	54W21	OX	OX
	MERV 13	52W39	OX	OX
Replaceable Media Filter with Metal Mesh Frame (includes Non-Pleated Filter Media) 508 x 508 x 51 mm - order 12 per unit		44N60	X	X
Indoor Air Quality (CO₂) Sensors				
Sensor - Wall-mount, off-white plastic cover with LCD display		77N39	X	X
Sensor - Wall-mount, off-white plastic cover, no display		87N53	X	X
Sensor - Black plastic case with LCD display, rated for plenum mounting		87N52	X	X
Sensor - Wall-mount, black plastic case, no display, rated for plenum mounting		87N54	X	X
CO ₂ Sensor Duct Mounting Kit - for downflow applications		85L43	X	X
Aspiration Box - for duct mounting non-plenum rated CO ₂ sensors (87N53 or 77N39)		90N43	X	X
ELECTRICAL				
Voltage 50 Hz with neutral	380/420V - 3 phase	Factory	O	O

NOTE - Catalog and model numbers shown are for ordering field installed accessories.

OX - Configure To Order (Factory Installed) or Field Installed

O = Configure To Order (Factory Installed)

X = Field Installed

OPTIONS / ACCESSORIES

Item Description	Catalog Number	Unit Model No	
		300	360
ECONOMIZER			
High Performance Economizer			
High Performance Economizer Downflow or Horizontal Applications - Includes Outdoor Air Hood, order Downflow or Horizontal Barometric Relief Dampers separately.	18X87	OX	OX
Economizer Controls			
Differential Enthalpy	Order 2 21Z09	OX	OX
Sensible Control	Sensor is Furnished Factory	O	O
Single Enthalpy	21Z09	OX	OX
Global, Enthalpy	Sensor Field Provided Factory	O	O
Differential Sensible	Sensor is Furnished Factory	O	O
Barometric Relief			
Downflow Barometric Relief Dampers - (Hood Furnished)	76W17	OX	OX
Horizontal Barometric Relief Dampers - (Hood Furnished)	33K78	OX	OX
OUTDOOR AIR			
Outdoor Air Dampers With Exhaust Hood			
Motorized	18X89	OX	OX
Manual	18X88	OX	OX
POWER EXHAUST			
Standard Static	380/420V 74W24	OX	OX
ROOF CURBS			
Hybrid Roof Curbs, Downflow			
356 mm height	C1CURB71D-1 11F62	X	X
457 mm height	C1CURB72D-1 11F63	X	X
610 mm height	C1CURB73D-1 11F64	X	X
Standard Roof Curbs, Horizontal - Requires Horizontal Return Air Panel Kit			
762 mm height - slab applications	C1CURB15C-1 11T90	X	X
1041 mm height - rooftop applications	C1CURB17C-1 11T97	X	X
Horizontal Return Air Panel Kit (Required)	38K48	X	X
Insulation Kit For Standard Horizontal Curbs			
	for C1CURB15C-1 73K33	X	X
	for C1CURB17C-1 73K35	X	X
CEILING DIFFUSERS			
Step-Down - Order one	LARTD30/36S 45K74	X	X
Flush - Order one	LAFD30/36S 45K75	X	X
Transitions (Supply and Return) - Order one	LASRT30/36 33K80	X	X

NOTE - Catalog and model numbers shown are for ordering field installed accessories.

OX - Configure To Order (Factory Installed) or Field Installed

O = Configure To Order (Factory Installed)

X = Field Installed

SPECIFICATIONS

General Data		Nominal kW (Tons)	88 (25)	105 (30)
		Model Number	LGH300H4B	LGH360H4B
		Efficiency Type	High	High
		Blower Type	Constant Air Volume (CAV)	Constant Air Volume (CAV)
Cooling Performance	Gross Cooling Capacity - kW (Btuh)		76.8 (262 000)	96.7 (314 000)
	¹ Net Cooling Capacity - kW (Btuh)		74.4 (254 000)	93.2 (302 000)
	AHRI Rated Air Flow - L/s (cfm)		3825 (8100)	4530 (9600)
	Total Unit Power - kW		21.6	27.9
	¹ EER (Btuh/Watt) at 35°C (95°F)		11.8	10.8
	² EER (Btuh/Watt) at 46°C (115°F)		8.4	8.6
	¹ IEER (Btuh/Watt)		12.5	11.5
	Refrigerant Type		R-410A	R-410A
	Refrigerant Charge	Circuit 1	4.2 kg (9 lbs. 4 oz.)	4.1 kg (9 lbs. 0 oz.)
		Circuit 2	4.1 kg (9 lbs. 0 oz.)	3.6 kg (8 lbs. 0 oz.)
	Circuit 3	4.0 kg (8 lbs. 13 oz.)	4.1 kg (9 lbs. 0 oz.)	
	Circuit 4	3.9 kg (8 lbs. 9 oz.)	3.4 kg (7 lbs. 8 oz.)	
Gas Heating Options Available - See page 16			Standard (2 Stage), Medium (2 Stage), or High (2 Stage)	
Compressor Type (number)			Scroll (4)	Scroll (4)
Outdoor Coils	Net face area - m ² (sq. ft.) total		6.4 (68.3)	6.4 (68.3)
	Number of rows		1	1
	Fins per m (Fins per inch)		906 (23)	906 (23)
Outdoor Coil Fans	Motor - (No.) W (hp)		(6) 249 (1/3)	(6) 249 (1/3)
	Motor rev/min		900	900
	Total Motor watts		1775	1775
	Diameter - mm (in.)		(6) 610 (24)	(6) 610 (24)
	Number of blades		3	3
	Total Air volume - L/s (cfm)		8450 (17 900)	8450 (17 900)
Indoor Coils	Net face area - m ² (sq. ft.) total		2.9 (31.40)	2.9 (31.40)
	Tube diameter - mm (in.)		9.5 (3/8)	9.5 (3/8)
	Number of rows		4	4
	Fins per m (Fins per inch)		551 (14)	(551) 14
	Drain connection - No. and size		(1) 1 in. NPT	(1) 1 in. NPT
	Expansion device type		Balance port Thermostatic Expansion Valve (TXV), removable head	
³ Indoor Blower and Kit Selection	Nominal motor output		3.7 kW (5 hp) - 5.6 kW (7.5 hp) - 7.5 kW (10 hp)	
	Maximum usable motor output		4.3 kW (5.75 hp) - 6.4 kW (8.63 hp) - 8.6 kW (11.5 hp)	
	Motor - Drive kit		3.7 kW (5 hp) Kit 5 - 550-675 rev/min Kit 6 - 640-805 rev/min Kit 7 - 475-600 rev/min Kit 8 - 400-525 rev/min	3.7 kW (5 hp) Kit 5 - 550-675 rev/min Kit 6 - 640-805 rev/min Kit 7 - 475-600 rev/min
			5.6 kW (7.5 hp) Kit 3 - 595-730 rev/min Kit 4 - 640-805 rev/min	5.6 kW (7.5 hp) Kit 3 - 595-730 rev/min Kit 4 - 640-805 rev/min
			7.5 kW (10 hp) Kit 1 - 615-745 rev/min Kit 2 - 725-870 rev/min	7.5 kW (10 hp) Kit 1 - 615-745 rev/min Kit 2 - 725-870 rev/min
	Blower wheel nominal diameter and width - mm (in.)		(2) 457 x 381 (18 x 15)	
	Filters	Type of filter		Fiberglass, disposable
Number and size - mm (in.)			(12) 508 x 508 x 51 (20 x 20 x 2)	
Electrical characteristics			380/420V - 50 hertz - 3 phase with neutral (No neutral on CE marked models)	

NOTE - Net capacity includes evaporator blower motor heat deduction. Gross capacity does not include evaporator blower motor heat deduction.

¹ Tested at conditions based on AHRI Standard 340/360; 35°C (95°F) outdoor air temperature and 27°C (80°F) dry bulb/19°C (67°F) wet bulb entering evaporator air; minimum external duct static pressure while operating at rated voltage and air volumes.

² Rated at 46°C (115°F) outdoor air temperature and 27°C (80°F) db/19°C (67°F) wb entering evaporator air (T3 Conditions).

³ Using total air volume and system static pressure requirements determine from blower performance tables rev/min and motor output required. Maximum usable output of motors furnished are shown. See Belt Drive Specification Table for maximum usable motor output. If motors of comparable output are used, be sure to keep within the service factor limitations outlined on the motor nameplate.

SPECIFICATIONS - GAS HEAT

Usage Data			LGH300 LGH360		
			Standard (S)	Medium (M)	High (H)
Heat Input Type					
Number of Gas Heat Stages			2	2	2
Gas Heating Performance	Input - kW (Btuh)	First Stage	49.5 (169 000)	68.6 (234 000)	91.4 (312 000)
		Second Stage	68.5 (234 000)	91.9 (314 000)	123.0 (420 000)
	Output - kW (Btuh)	First Stage	---	---	---
		Second Stage	54.8 (187 000)	73.5 (251 000)	98.4 (336 000)
Temperature Rise Range - °C (°F)			6 - 22 (10 - 40)	8 - 25 (15 - 45)	11 - 28 (20 - 50)
Thermal Efficiency			80.0%	80.0%	80.0%
Gas Supply Connections			1 in. NPT	1 in. NPT	1 in. NPT
Recommended Gas Supply Pressure - Pa (in. w.g.)	Natural		1.7 (7)	1.7 (7)	1.7 (7)
	LPG/Propane		2.7 (11)	2.7 (11)	2.7 (11)

HIGH ALTITUDE DERATE

Units may be installed at altitudes up to 610 m (2000 ft.) above sea level without any modification. At altitudes above 610 m (2000 ft.), units must be derated to match gas manifold pressures shown in table below.

At altitudes above 1372 m (4500 ft.) unit must be derated 2% for each 305 m (1000 ft.) above sea level.

NOTE - This is the only permissible derate for these units.

Gas Heat Type	Altitude - m (ft.)	Input Rate			
		Gas Manifold Pressure - Pa (in. w.g.)		Natural Gas or LPG/Propane - kW (Btuh)	
		Natural Gas	LPG/Propane Gas	First Stage	Second Stage
Standard (S)	610- 1372 (2001 - 4500)	0.5 (2.6)	1.8 (7.3)	49.5 (169 000)	66.0 (225 500)
Medium (M)	610 - 1372 (2001 - 4500)	0.5 (2.6)	1.8 (7.3)	68.6 (234 000)	88.7 (303 400)
High (H)	610 - 1372 (2001 - 4500)	0.5 (2.6)	1.8 (7.3)	91.4 (312 000)	118.6 (405 000)

RATINGS

NOTE – For Temperatures and Capacities not shown in tables, see bulletin – Cooling Unit Rating Table Correction Factor Data in Miscellaneous Engineering Data section.

88 kW - LGH300H4 (1ST STAGE)

Entering Wet Bulb Temperature	Total Air Volume	Outdoor Air Temperature Entering Outdoor Coil																				
		18.3°C						23.9°C					29.4°C					35°C				
		Total Cool Cap.	Comp. Motor Input	Sensible To Total Ratio (S/T)			Total Cool Cap.	Comp. Motor Input	Sensible To Total Ratio (S/T)			Total Cool Cap.	Comp. Motor Input	Sensible To Total Ratio (S/T)			Total Cool Cap.	Comp. Motor Input	Sensible To Total Ratio (S/T)			
				Dry Bulb					Dry Bulb					Dry Bulb					Dry Bulb			
L/s	kW	kW	24°C	27°C	29°C	kW	kW	24°C	27°C	29°C	kW	kW	24°C	27°C	29°C	kW	kW	24°C	27°C	29°C		
17.2°C	3776	43.1	6.21	0.74	0.87	0.99	41.1	6.92	0.74	0.88	1	39	7.72	0.75	0.9	1	36.9	8.63	0.76	0.92	1	
	4719	45.2	6.31	0.79	0.95	1	43.2	7.01	0.79	0.96	1	41.1	7.81	0.81	0.98	1	39	8.73	0.83	1	1	
	5663	47.1	6.4	0.84	1	1	45.3	7.11	0.85	1	1	43.2	7.91	0.87	1	1	41.2	8.83	0.89	1	1	
19.4°C	3776	45.7	6.33	0.58	0.71	0.84	43.7	7.04	0.58	0.72	0.85	41.6	7.83	0.58	0.73	0.87	39.4	8.75	0.58	0.74	0.89	
	4719	47.9	6.43	0.61	0.77	0.92	45.7	7.13	0.62	0.78	0.93	43.5	7.92	0.62	0.79	0.95	41.2	8.83	0.63	0.8	0.97	
	5663	49.4	6.51	0.65	0.82	0.98	47.2	7.2	0.65	0.83	0.99	45	7.99	0.67	0.85	1	42.6	8.89	0.66	0.87	1	
21.7°C	3776	48.8	6.47	0.44	0.57	0.69	46.7	7.18	0.44	0.57	0.7	44.5	7.97	0.43	0.57	0.71	42.2	8.87	0.43	0.57	0.72	
	4719	50.9	6.58	0.45	0.6	0.75	48.7	7.28	0.45	0.61	0.76	46.5	8.06	0.44	0.61	0.77	44	8.97	0.44	0.62	0.78	
	5663	52.4	6.66	0.46	0.64	0.8	50.2	7.35	0.46	0.64	0.82	47.9	8.14	0.46	0.66	0.83	45.3	9.03	0.46	0.66	0.85	

88 kW - LGH300H4 (2ND STAGE)

Entering Wet Bulb Temperature	Total Air Volume	Outdoor Air Temperature Entering Outdoor Coil																				
		26.7°C						35°C					43.3°C					46°C				
		Total Cool Cap.	Comp. Motor Input	Sensible To Total Ratio (S/T)			Total Cool Cap.	Comp. Motor Input	Sensible To Total Ratio (S/T)			Total Cool Cap.	Comp. Motor Input	Sensible To Total Ratio (S/T)			Total Cool Cap.	Comp. Motor Input	Sensible To Total Ratio (S/T)			
				Dry Bulb					Dry Bulb					Dry Bulb					Dry Bulb			
L/s	kW	kW	24°C	27°C	29°C	kW	kW	24°C	27°C	29°C	kW	kW	24°C	27°C	29°C	kW	kW	24°C	27°C	29°C		
17.2°C	3775	77.6	14.59	0.76	0.91	1.00	71.7	17.27	0.77	0.93	1.00	64.9	20.63	0.79	0.97	1.00	62.5	21.88	0.81	0.99	1.00	
	4720	81.6	14.79	0.82	0.98	1.00	75.6	17.46	0.84	1.00	1.00	69.3	20.84	0.87	1.00	1.00	67.6	22.11	0.89	1.00	1.00	
	5665	85.8	14.99	0.87	1.00	1.00	79.9	17.68	0.90	1.00	1.00	73.2	21.02	0.94	1.00	1.00	71.2	22.26	0.96	1.00	1.00	
19.4°C	3775	82.9	14.85	0.59	0.74	0.88	76.7	17.51	0.59	0.75	0.90	69.5	20.84	0.60	0.77	0.93	66.9	22.05	0.61	0.80	0.92	
	4720	86.5	15.03	0.63	0.80	0.96	80.1	17.68	0.63	0.82	0.98	72.7	20.99	0.65	0.85	1.00	69.8	22.20	0.66	0.89	1.00	
	5665	89.4	15.17	0.67	0.86	1.00	82.6	17.80	0.68	0.88	1.00	75.0	21.12	0.70	0.92	1.00	72.2	22.32	0.71	0.96	1.00	
21.7°C	3775	88.3	15.12	0.44	0.58	0.72	81.9	17.77	0.43	0.58	0.73	74.7	21.10	0.42	0.59	0.75	71.9	22.30	0.42	0.60	0.72	
	4720	92.2	15.32	0.45	0.62	0.78	85.4	17.95	0.45	0.63	0.80	77.7	21.26	0.44	0.64	0.83	75.0	22.47	0.44	0.67	0.80	
	5665	94.8	15.46	0.47	0.66	0.84	87.9	18.08	0.47	0.68	0.86	79.9	21.37	0.47	0.69	0.90	77.0	22.58	0.47	0.72	0.87	

Entering Wet Bulb Temperature	Total Air Volume	Outdoor Air Temperature Entering Outdoor Coil																	
		48°C						50°C					51.7°C						
		Total Cool Cap.	Comp. Motor Input	Sensible To Total Ratio (S/T)			Total Cool Cap.	Comp. Motor Input	Sensible To Total Ratio (S/T)			Total Cool Cap.	Comp. Motor Input	Sensible To Total Ratio (S/T)					
				Dry Bulb					Dry Bulb					Dry Bulb					
L/s	kW	kW	24°C	27°C	29°C	kW	kW	24°C	27°C	29°C	kW	kW	24°C	27°C	29°C				
17.2°C	3775	60.4	22.87	0.81	0.99	1.00	58.4	23.89	0.82	1.00	1.00	56.9	24.80	0.83	1.00	1.00			
	4720	65.1	23.09	0.89	1.00	1.00	63.1	24.10	0.91	1.00	1.00	61.5	25.02	0.92	1.00	1.00			
	5665	68.6	23.24	0.97	1.00	1.00	66.6	24.27	0.98	1.00	1.00	64.8	25.16	0.99	1.00	1.00			
19.4°C	3775	64.7	23.05	0.60	0.79	0.96	62.5	24.08	0.61	0.80	0.97	60.6	24.95	0.61	0.81	0.98			
	4720	67.6	23.17	0.65	0.87	1.00	65.3	24.20	0.66	0.89	1.00	63.4	25.10	0.67	0.90	1.00			
	5665	69.8	23.29	0.71	0.95	1.00	67.5	24.31	0.72	0.96	1.00	65.4	25.19	0.73	0.97	1.00			
21.7°C	3775	69.6	23.27	0.41	0.60	0.77	67.2	24.29	0.41	0.60	0.78	65.3	25.20	0.41	0.60	0.78			
	4720	72.4	23.43	0.44	0.65	0.85	69.9	24.42	0.44	0.66	0.86	67.8	25.32	0.44	0.66	0.87			
	5665	74.4	23.54	0.46	0.71	0.93	72.0	24.55	0.46	0.72	0.94	69.8	25.44	0.47	0.73	0.95			

RATINGS

NOTE – For Temperatures and Capacities not shown in tables, see bulletin – Cooling Unit Rating Table Correction Factor Data in Miscellaneous Engineering Data section.

105 kW - LGH360H4 (1ST STAGE)

Entering Wet Bulb Temperature	Total Air Volume	Outdoor Air Temperature Entering Outdoor Coil																			
		18.3°C					23.9°C					29.4°C					35°C				
		Total Cool Cap.	Comp. Motor Input	Sensible To Total Ratio (S/T)			Total Cool Cap.	Comp. Motor Input	Sensible To Total Ratio (S/T)			Total Cool Cap.	Comp. Motor Input	Sensible To Total Ratio (S/T)			Total Cool Cap.	Comp. Motor Input	Sensible To Total Ratio (S/T)		
				Dry Bulb					Dry Bulb					Dry Bulb					Dry Bulb		
L/s	kW	kW	24°C	27°C	29°C	kW	kW	24°C	27°C	29°C	kW	kW	24°C	27°C	29°C	kW	kW	24°C	27°C	29°C	
17.2°C	4455	51.5	8.07	0.73	0.86	0.99	49.2	8.94	0.73	0.88	1	46.9	9.92	0.74	0.89	1	44.6	11.06	0.75	0.91	1
	5569	54	8.2	0.78	0.94	1	51.5	9.06	0.79	0.96	1	49.2	10.04	0.8	0.98	1	46.8	11.18	0.81	0.99	1
	6683	56	8.31	0.83	1	1	53.7	9.18	0.85	1	1	51.5	10.16	0.86	1	1	49.1	11.32	0.88	1	1
19.4°C	4455	54.5	8.23	0.57	0.71	0.83	52.1	9.09	0.58	0.71	0.85	49.7	10.07	0.58	0.72	0.86	47.2	11.21	0.58	0.73	0.88
	5569	56.8	8.35	0.61	0.76	0.91	54.3	9.21	0.61	0.77	0.93	51.8	10.18	0.62	0.78	0.95	49.2	11.32	0.62	0.8	0.96
	6683	58.5	8.44	0.64	0.82	0.98	56	9.3	0.65	0.83	0.99	53.4	10.29	0.65	0.85	1	50.8	11.42	0.66	0.86	1
21.7°C	4455	57.9	8.41	0.44	0.56	0.69	55.4	9.27	0.43	0.57	0.69	52.9	10.25	0.43	0.57	0.7	50.3	11.39	0.42	0.57	0.71
	5569	60.3	8.54	0.45	0.6	0.75	57.6	9.4	0.45	0.6	0.75	55.1	10.38	0.44	0.61	0.76	52.4	11.51	0.44	0.61	0.77
	6683	62	8.64	0.46	0.64	0.8	59.2	9.49	0.46	0.64	0.81	56.6	10.46	0.46	0.64	0.83	53.9	11.6	0.46	0.66	0.84

105 kW - LGH360H4 (2ND STAGE)

Entering Wet Bulb Temperature	Total Air Volume	Outdoor Air Temperature Entering Outdoor Coil																			
		26.7°C					35°C					43.3°C					46°C				
		Total Cool Cap.	Comp. Motor Input	Sensible To Total Ratio (S/T)			Total Cool Cap.	Comp. Motor Input	Sensible To Total Ratio (S/T)			Total Cool Cap.	Comp. Motor Input	Sensible To Total Ratio (S/T)			Total Cool Cap.	Comp. Motor Input	Sensible To Total Ratio (S/T)		
				Dry Bulb					Dry Bulb					Dry Bulb					Dry Bulb		
L/s	kW	kW	24°C	27°C	29°C	kW	kW	24°C	27°C	29°C	kW	kW	24°C	27°C	29°C	kW	kW	24°C	27°C	29°C	
17.2°C	4455	94.0	18.85	0.75	0.90	1.00	86.8	22.11	0.76	0.92	1.00	78.7	26.17	0.78	0.96	1.00	75.9	27.62	0.80	0.99	1.00
	5569	98.4	19.09	0.81	0.97	1.00	91.1	22.35	0.83	1.00	1.00	83.3	26.45	0.86	1.00	1.00	81.2	27.97	0.88	1.00	1.00
	6683	102.7	19.33	0.87	1.00	1.00	95.6	22.63	0.89	1.00	1.00	87.7	26.73	0.93	1.00	1.00	85.2	28.22	0.96	1.00	1.00
19.4°C	4455	99.9	19.17	0.58	0.73	0.87	92.3	22.44	0.58	0.74	0.89	83.8	26.48	0.59	0.76	0.93	80.5	27.92	0.60	0.79	0.92
	5569	104.0	19.41	0.62	0.79	0.95	96.0	22.66	0.63	0.81	0.98	87.2	26.70	0.64	0.84	1.00	83.9	28.15	0.66	0.88	1.00
	6683	107.1	19.58	0.66	0.85	1.00	98.9	22.83	0.67	0.88	1.00	89.7	26.85	0.68	0.91	1.00	86.5	28.32	0.70	0.96	1.00
21.7°C	4455	105.9	19.51	0.43	0.57	0.71	98.0	22.77	0.43	0.57	0.72	89.4	26.84	0.42	0.59	0.74	86.2	28.31	0.42	0.61	0.72
	5569	110.2	19.77	0.45	0.62	0.77	102.0	23.01	0.44	0.62	0.79	92.8	27.05	0.44	0.63	0.82	89.4	28.51	0.44	0.66	0.80
	6683	113.2	19.95	0.46	0.65	0.83	104.8	23.19	0.46	0.67	0.86	95.1	27.22	0.46	0.68	0.89	91.6	28.65	0.47	0.71	0.87
Entering Wet Bulb Temperature	Total Air Volume	Outdoor Air Temperature Entering Outdoor Coil																			
		48°C					50°C					51.7°C									
		Total Cool Cap.	Comp. Motor Input	Sensible To Total Ratio (S/T)			Total Cool Cap.	Comp. Motor Input	Sensible To Total Ratio (S/T)			Total Cool Cap.	Comp. Motor Input	Sensible To Total Ratio (S/T)							
				Dry Bulb					Dry Bulb					Dry Bulb							
L/s	kW	kW	24°C	27°C	29°C	kW	kW	24°C	27°C	29°C	kW	kW	24°C	27°C	29°C						
17.2°C	4455	73.2	28.80	0.80	0.98	1.00	70.7	29.99	0.81	0.99	1.00	68.6	31.08	0.82	1.00	1.00					
	5569	78.2	29.13	0.88	0.1	1.00	75.8	30.34	0.89	1.00	1.00	73.7	31.43	0.91	1.00	1.00					
	6683	82.0	29.38	0.96	1.00	1.00	79.5	30.59	0.97	1.00	1.00	77.2	31.69	0.98	1.00	1.00					
19.4°C	4455	77.9	29.10	0.60	0.78	0.95	75.2	30.30	0.60	0.79	0.97	72.8	31.38	0.60	0.80	0.98					
	5569	81.0	29.32	0.65	0.86	1.00	78.2	30.50	0.65	0.87	1.00	75.9	31.60	0.66	0.89	1.00					
	6683	83.4	29.48	0.70	0.94	1.00	80.5	30.69	0.71	0.95	1.00	78.1	31.76	0.72	0.97	1.00					
21.7°C	4455	83.1	29.45	0.41	0.59	0.76	80.4	30.67	0.41	0.59	0.77	77.9	31.73	0.41	0.60	0.78					
	5569	86.4	29.69	0.44	0.65	0.84	83.3	30.90	0.44	0.65	0.85	80.5	31.93	0.44	0.66	0.87					
	6683	88.5	29.82	0.46	0.70	0.92	85.5	31.03	0.46	0.71	0.94	82.7	32.09	0.46	0.72	0.95					

BLOWER DATA

BLOWER TABLE INCLUDES RESISTANCE FOR BASE UNIT ONLY WITH DRY INDOOR COIL & AIR FILTERS IN PLACE
FOR ALL UNITS ADD:

- 1 - Wet indoor coil air resistance of selected unit.
- 2 - Any factory installed options air resistance (electric heat, economizer, etc.)
- 3 - Any field installed accessories air resistance (electric heat, duct resistance, diffuser, etc.)

Then determine from blower table blower motor output and drive required.

See page 21 for wet coil and option/accessory air resistance data.

See page 21 for factory installed drive kit specifications.

Air Volume		TOTAL STATIC PRESSURE - Pa (Inches Water Gauge)																	
		100 (0.40)			150 (0.60)			200 (0.80)			250 (1.00)			300 (1.20)			350 (1.40)		
L/s	cfm	rev/min	kW	BHP	rev/min	kW	BHP	rev/min	kW	BHP	rev/min	kW	BHP	rev/min	kW	BHP	rev/min	kW	BHP
1890	4000	433	0.49	0.66	497	0.74	0.99	565	0.95	1.27	630	1.15	1.54	687	1.33	1.78	738	1.52	2.04
2125	4500	441	0.59	0.79	506	0.83	1.11	574	1.05	1.41	638	1.26	1.69	694	1.45	1.94	744	1.65	2.21
2360	5000	451	0.7	0.94	516	0.93	1.25	584	1.16	1.55	646	1.38	1.85	702	1.58	2.12	751	1.79	2.40
2595	5500	462	0.81	1.09	527	1.04	1.39	594	1.28	1.72	655	1.51	2.02	710	1.72	2.31	758	1.95	2.61
2830	6000	473	0.93	1.25	539	1.16	1.55	605	1.42	1.90	665	1.65	2.21	718	1.87	2.51	766	2.11	2.83
3070	6500	486	1.06	1.42	551	1.3	1.74	616	1.56	2.09	675	1.8	2.41	727	2.04	2.73	774	2.29	3.07
3300	7000	499	1.19	1.60	565	1.44	1.93	628	1.73	2.32	685	1.97	2.64	737	2.22	2.98	782	2.49	3.34
3540	7500	513	1.34	1.80	579	1.6	2.14	641	1.9	2.55	696	2.15	2.88	747	2.42	3.24	792	2.71	3.63
3775	8000	528	1.49	2.00	593	1.78	2.39	653	2.1	2.82	708	2.35	3.15	757	2.63	3.53	801	2.95	3.95
4010	8500	544	1.66	2.23	608	1.98	2.65	667	2.31	3.10	720	2.57	3.45	768	2.87	3.85	812	3.21	4.30
4245	9000	561	1.85	2.48	624	2.2	2.95	681	2.54	3.40	733	2.8	3.75	780	3.13	4.20	823	3.5	4.69
4480	9500	578	2.05	2.75	640	2.44	3.27	696	2.78	3.73	746	3.06	4.10	792	3.42	4.58	834	3.81	5.11
4720	10 000	596	2.28	3.06	657	2.69	3.61	711	3.04	4.08	760	3.34	4.48	805	3.73	5.00	845	4.15	5.56
4955	10 500	615	2.53	3.39	674	2.95	3.95	727	3.31	4.44	775	3.65	4.89	817	4.07	5.46	857	4.52	6.06
5190	11 000	634	2.79	3.74	692	3.22	4.32	744	3.61	4.84	789	3.99	5.35	830	4.44	5.95	869	4.91	6.58
5425	11 500	653	3.07	4.12	711	3.51	4.71	760	3.93	5.27	803	4.36	5.84	843	4.84	6.49	881	5.32	7.13
5660	12 000	674	3.38	4.53	729	3.83	5.13	776	4.29	5.75	818	4.77	6.39	857	5.27	7.06	894	5.75	7.71
5900	12 500	695	3.72	4.99	748	4.2	5.63	792	4.69	6.29	832	5.21	6.98	870	5.72	7.67	906	6.21	8.32
6130	13 000	715	4.1	5.50	766	4.61	6.18	808	5.14	6.89	847	5.68	7.61	883	6.21	8.32	918	6.7	8.98
6370	13 500	736	4.52	6.06	784	5.06	6.78	824	5.62	7.53	861	6.18	8.28	896	6.72	9.01	930	7.21	9.66
6605	14 000	757	4.98	6.68	801	5.55	7.44	839	6.14	8.23	875	6.71	8.99	909	7.25	9.72	943	7.74	10.38
6840	14 500	777	5.48	7.35	818	6.08	8.15	854	6.69	8.97	889	7.27	9.75	922	7.81	10.47	955	8.3	11.13
7075	15 000	797	6.02	8.07	834	6.66	8.93	868	7.28	9.76	902	7.86	10.54	935	8.4	11.26	---	---	---

BLOWER DATA

BLOWER TABLE INCLUDES RESISTANCE FOR BASE UNIT ONLY WITH DRY INDOOR COIL & AIR FILTERS IN PLACE
FOR ALL UNITS ADD:

- 1 - Wet indoor coil air resistance of selected unit.
- 2 - Any factory installed options air resistance (electric heat, economizer, etc.)
- 3 - Any field installed accessories air resistance (electric heat, duct resistance, diffuser, etc.)

Then determine from blower table blower motor output and drive required.

See page 21 for wet coil and option/accessory air resistance data.

See page 21 for factory installed drive kit specifications.

Air Volume		TOTAL STATIC PRESSURE - Pa (Inches Water Gauge)																	
		400 (1.60)			450 (1.80)			500 (2.00)			550 (2.20)			600 (2.40)			650 (2.60)		
L/s	cfm	rev/min	kW	BHP	rev/min	kW	BHP	rev/min	kW	BHP	rev/min	kW	BHP	rev/min	kW	BHP	rev/min	kW	BHP
1890	4000	784	1.72	2.31	824	1.91	2.56	861	2.1	2.82	897	2.31	3.10	932	2.54	3.40	---	---	---
2125	4500	790	1.86	2.49	831	2.07	2.77	868	2.28	3.06	903	2.5	3.35	938	2.73	3.66	974	2.99	4.01
2360	5000	796	2.01	2.69	837	2.24	3.00	874	2.46	3.30	909	2.69	3.61	944	2.94	3.94	980	3.21	4.30
2595	5500	802	2.18	2.92	843	2.42	3.24	880	2.66	3.57	916	2.9	3.89	951	3.15	4.22	987	3.43	4.60
2830	6000	809	2.36	3.16	850	2.62	3.51	887	2.87	3.85	922	3.12	4.18	957	3.38	4.53	994	3.66	4.91
3070	6500	817	2.56	3.43	857	2.83	3.79	894	3.1	4.16	929	3.35	4.49	964	3.62	4.85	1001	3.91	5.24
3300	7000	825	2.78	3.73	864	3.07	4.12	901	3.34	4.48	937	3.6	4.83	971	3.87	5.19	1008	4.17	5.59
3540	7500	833	3.02	4.05	872	3.32	4.45	909	3.61	4.84	945	3.88	5.20	979	4.15	5.56	1016	4.45	5.97
3775	8000	843	3.28	4.40	881	3.6	4.83	918	3.89	5.21	953	4.17	5.59	988	4.45	5.97	1025	4.75	6.37
4010	8500	852	3.56	4.77	890	3.89	5.21	927	4.2	5.63	962	4.49	6.02	997	4.77	6.39	1034	5.08	6.81
4245	9000	862	3.87	5.19	900	4.22	5.66	936	4.53	6.07	972	4.82	6.46	1007	5.11	6.85	1044	5.43	7.28
4480	9500	873	4.21	5.64	910	4.56	6.11	946	4.88	6.54	982	5.17	6.93	1018	5.47	7.33	1055	5.8	7.77
4720	10 000	884	4.57	6.13	921	4.93	6.61	957	5.24	7.02	992	5.54	7.43	1028	5.86	7.86	1066	6.2	8.31
4955	10 500	895	4.94	6.62	932	5.31	7.12	967	5.63	7.55	1003	5.93	7.95	1039	6.27	8.40	1077	6.63	8.89
5190	11 000	907	5.34	7.16	943	5.71	7.65	978	6.03	8.08	1013	6.35	8.51	1050	6.7	8.98	1089	7.08	9.49
5425	11 500	918	5.75	7.71	954	6.13	8.22	989	6.46	8.66	1025	6.78	9.09	1062	7.15	9.58	1101	7.55	10.12
5660	12 000	930	6.19	8.30	965	6.57	8.81	1000	6.9	9.25	1036	7.24	9.71	1073	7.62	10.21	1112	8.03	10.76
5900	12 500	941	6.65	8.91	976	7.03	9.42	1011	7.37	9.88	1048	7.72	10.35	1085	8.1	10.86	1124	8.52	11.42
6130	13 000	953	7.13	9.56	988	7.51	10.07	1023	7.85	10.52	1059	8.21	11.01	---	---	---	---	---	---
6370	13 500	965	7.64	10.24	1000	8.01	10.74	1035	8.35	11.19	---	---	---	---	---	---	---	---	---
6605	14 000	977	8.16	10.94	1012	8.53	11.43	---	---	---	---	---	---	---	---	---	---	---	---

BLOWER DATA

FACTORY INSTALLED BELT DRIVE KIT SPECIFICATIONS

Nominal kW	Nominal hp	Maximum kW	Maximum hp	Drive Kit Number	Rev/min Range
3.7	5	4.3	5.75	5	550 - 675
3.7	5	4.3	5.75	6	640 - 805
3.7	5	4.3	5.75	7	475 - 600
3.7	5	4.3	5.75	8	400 - 525
3.7	5	4.3	5.75	9	340 - 445
5.6	7.5	6.4	8.63	3	595 - 730
5.6	7.5	6.4	8.63	4	640 - 805
7.5	10	8.6	11.50	1	615 - 745
7.5	10	8.6	11.50	2	725 - 870

NOTE - Using total air volume and system static pressure requirements determine from blower performance tables rev/min and motor output required. Maximum usable output of motors furnished as shown. If motors of comparable output are used, be sure to keep within the service factor limitations outlined on the motor nameplate.

FACTORY INSTALLED OPTIONS/FIELD INSTALLED ACCESSORY AIR RESISTANCE

Air Volume		Wet Indoor Coil		Gas Heat Exchanger						Economizer		Filters				Horizontal Roof Curb	
				Standard Heat		Medium Heat		High Heat				MERV 8		MERV 13			
L/s	cfm	Pa	in. w.g.	Pa	in. w.g.	Pa	in. w.g.	Pa	in. w.g.	Pa	in. w.g.	Pa	in. w.g.	Pa	in. w.g.	Pa	in. w.g.
1890	4000	10	0.04	20	0.08	20	0.08	27	0.11	0	0.00	0	0.00	0	0.00	10	0.04
2125	4500	10	0.04	22	0.09	25	0.10	32	0.13	0	0.00	0	0.00	0	0.00	12	0.05
2360	5000	12	0.05	25	0.10	30	0.12	37	0.15	0	0.00	0	0.00	0	0.00	15	0.06
2595	5500	15	0.06	27	0.11	35	0.14	42	0.17	2	0.01	0	0.00	2	0.01	17	0.07
2830	6000	17	0.07	30	0.12	40	0.16	47	0.19	2	0.01	0	0.00	5	0.02	20	0.08
3070	6500	20	0.08	32	0.13	45	0.18	52	0.21	2	0.01	2	0.01	5	0.02	22	0.09
3300	7000	22	0.09	35	0.14	50	0.20	60	0.24	5	0.02	2	0.01	7	0.03	25	0.10
3540	7500	25	0.10	37	0.15	52	0.21	62	0.25	5	0.02	2	0.01	10	0.04	27	0.11
3775	8000	27	0.11	42	0.17	60	0.24	70	0.28	5	0.02	2	0.01	10	0.04	32	0.13
4010	8500	30	0.12	50	0.20	67	0.27	77	0.31	7	0.03	2	0.01	10	0.04	37	0.15
4245	9000	32	0.13	55	0.22	72	0.29	85	0.34	10	0.04	2	0.01	10	0.04	42	0.17
4480	9500	35	0.14	60	0.24	80	0.32	94	0.38	10	0.04	5	0.02	15	0.06	47	0.19
4720	10 000	37	0.15	67	0.27	90	0.36	104	0.42	12	0.05	5	0.02	15	0.06	52	0.21
4955	10 500	40	0.16	75	0.30	99	0.40	114	0.46	15	0.06	5	0.02	15	0.06	60	0.24
5190	11 000	45	0.18	82	0.33	107	0.43	124	0.50	17	0.07	5	0.02	17	0.07	67	0.27
5425	11 500	47	0.19	92	0.37	119	0.48	137	0.55	20	0.08	5	0.02	20	0.08	75	0.30
5660	12 000	50	0.20	99	0.40	129	0.52	149	0.60	25	0.10	5	0.02	20	0.08	82	0.33
5900	12 500	52	0.21	109	0.44	142	0.57	162	0.65	27	0.11	7	0.03	25	0.10	92	0.37
6130	13 000	57	0.23	119	0.48	152	0.61	174	0.70	32	0.13	7	0.03	25	0.10	100	0.40
6370	13 500	60	0.24	132	0.53	167	0.67	189	0.76	35	0.14	7	0.03	27	0.11	110	0.44
6605	14 000	65	0.26	142	0.57	179	0.72	204	0.82	40	0.16	7	0.03	30	0.12	122	0.49
6840	14 500	67	0.27	154	0.62	194	0.78	221	0.89	45	0.18	10	0.04	32	0.13	132	0.53
7075	15 000	72	0.29	169	0.68	209	0.84	236	0.95	52	0.21	10	0.04	32	0.13	144	0.58

BLOWER DATA

CEILING DIFFUSER AIR RESISTANCE

Air Volume		Step-Down Diffuser - LARTD30/36S						Flush Diffuser - LAFD30/36S	
		2 Ends Open		1 Side/2 Ends Open		All Ends & Sides Open		Pa	in. w.g.
L/s	cfm	Pa	in. w.g.	Pa	in. w.g.	Pa	in. w.g.	Pa	in. w.g.
3540	7500	92	0.37	77	0.31	62	0.25	72	0.29
3775	8000	104	0.42	90	0.36	72	0.29	85	0.34
4010	8500	119	0.48	102	0.41	85	0.34	97	0.39
4245	9000	137	0.55	117	0.47	97	0.39	109	0.44
4485	9500	154	0.62	132	0.53	112	0.45	127	0.51
4720	10000	174	0.70	149	0.60	127	0.51	142	0.57
4955	10 500	194	0.78	169	0.68	144	0.58	162	0.65
5190	11 000	216	0.87	190	0.76	162	0.65	179	0.72
5425	11 500	241	0.97	211	0.85	182	0.73	201	0.81
5665	12 000	269	1.08	234	0.94	204	0.82	223	0.90
5900	12 500	296	1.19	259	1.04	226	0.91	246	0.99
6135	13 000	323	1.30	286	1.15	249	1.00	274	1.10
6370	13 500	356	1.43	313	1.26	374	1.10	298	1.20
6605	14 000	388	1.56	343	1.38	298	1.20	326	1.31
6845	14 500	420	1.69	373	1.50	326	1.31	356	1.43
7080	15 000	457	1.84	405	1.63	356	1.43	388	1.56

CEILING DIFFUSER AIR THROW DATA

Air Volume		1 Effective Throw Range			
		Step-Down		Flush	
L/s	cfm	m	ft.	m	ft.
4245	9000	12 - 14	40 - 47	8 - 11	29 - 35
4485	9500	13 - 15	43 - 50	10 - 12	33 - 41
4720	10 000	14 - 16	46 - 54	11 - 14	37 - 46
4955	10 500	15 - 18	50 - 58	13 - 15	42 - 51
4190	11 000	16 - 19	53 - 61	14 - 17	46 - 56
5425	11 500	17 - 20	55 - 64	15 - 19	50 - 61
5665	12 000	18 - 20	58 - 67	16 - 20	54 - 66
5900	12 500	19 - 22	61 - 71	18 - 22	58 - 71
6135	13 000	20 - 23	64 - 74	19 - 23	62 - 75
6370	13 500	20 - 23	67 - 77	20 - 24	66 - 79

¹ Throw is the horizontal or vertical distance an airstream travels on leaving the outlet or diffuser before the maximum velocity is reduced to 15 m (50 ft.) per minute. Four sides open.

POWER EXHAUST FAN PERFORMANCE - STANDARD STATIC

Return Duct Negative Static Pressure		Air Volume Exhausted	
Pa	in. w.g.	L/s	cfm
0	0	6040	12 800
12	0.05	5760	12 200
25	0.10	5430	11 500
37	0.15	5100	10 800
50	0.20	4670	9900
62	0.25	4250	9000
75	0.30	3730	7900
87	0.35	3190	6750
100	0.40	2570	5450
112	0.45	1960	4150
125	0.50	1370	2900

ELECTRICAL DATA

		LGH300H4B			LGH360H4B		
¹ Voltage - 50hz 3 Phase with neutral		380/420V			380/420V		
Compressor 1	Rated Load Amps	10.6			12.2		
	Locked Rotor Amps	74			101		
Compressor 2	Rated Load Amps	10.6			12.2		
	Locked Rotor Amps	74			101		
Compressor 3	Rated Load Amps	10.6			12.2		
	Locked Rotor Amps	74			101		
Compressor 4	Rated Load Amps	10.6			12.2		
	Locked Rotor Amps	74			101		
Outdoor Fan Motors (6)	Full Load Amps	1.3			1.3		
	(total)	(7.8)			(7.8)		
Standard Power Exhaust (3) 0.25 kW	Full Load Amps	1.3			1.3		
	(total)	(3.9)			(3.9)		
Indoor Blower Motor	kW	3.7	5.6	7.5	3.7	5.6	7.5
	Full Load Amps	8.2	11.7	16.3	8.2	11.7	16.3
² Maximum Overcurrent Protection	Unit Only	70	70	80	80	80	90
	With (3) 0.25 kW Standard Power Exhaust	70	80	90	80	80	90
³ Minimum Circuit Ampacity	Unit Only	62	65	71	68	72	77
	With (3) 0.25 kW Standard Power Exhaust	65	69	75	72	76	81

¹ Extremes of operating range are plus and minus 10% of line voltage.

² Heating, Air Conditioning type breaker or fuse.

³ Refer to local electrical code to determine wire, fuse and disconnect size requirements.

⁴ Nominal kW based on 420V-3ph-50hz.

UNIT CLEARANCES

Unit With Economizer

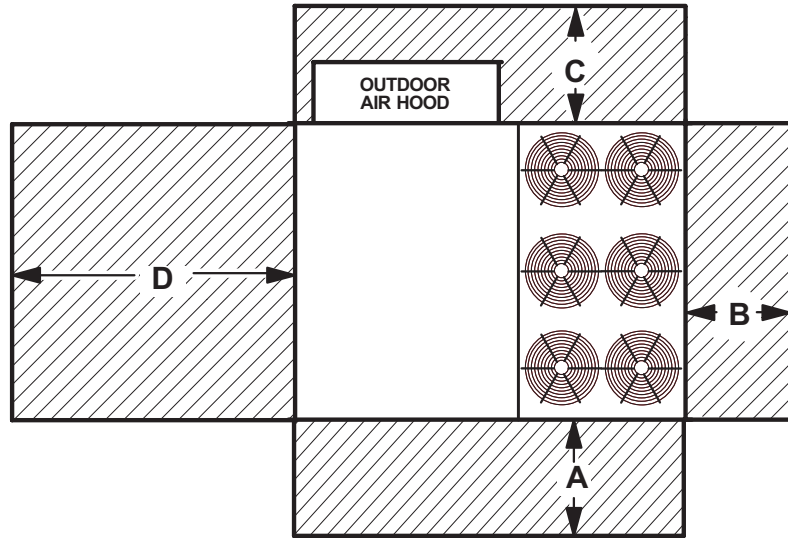

1 Unit Clearance	A		B		C		D		Top Clearance
	mm	in.	mm	in.	mm	in.	mm	in.	
Service Clearance	1524	60	914	36	914	36	1676	66	Unobstructed
Clearance to Combustibles	914	36	25	1	25	1	25	1	
Minimum Operation Clearance	1143	45	914	36	914	36	1041	41	

NOTE - Entire perimeter of unit base requires support when elevated above the mounting surface.

¹ **Service Clearance** - Required for removal of serviceable parts.

Clearance to Combustibles - Required clearance to combustible material.

Minimum Operation Clearance - Required clearance for proper unit operation.

Unit With Horizontal Barometric Relief Dampers

NOTE Allow adequate clearance for duct and barometric relief damper installation.

NOTE Dampers may be installed on each side of return air duct or end to end on one side of return air duct.

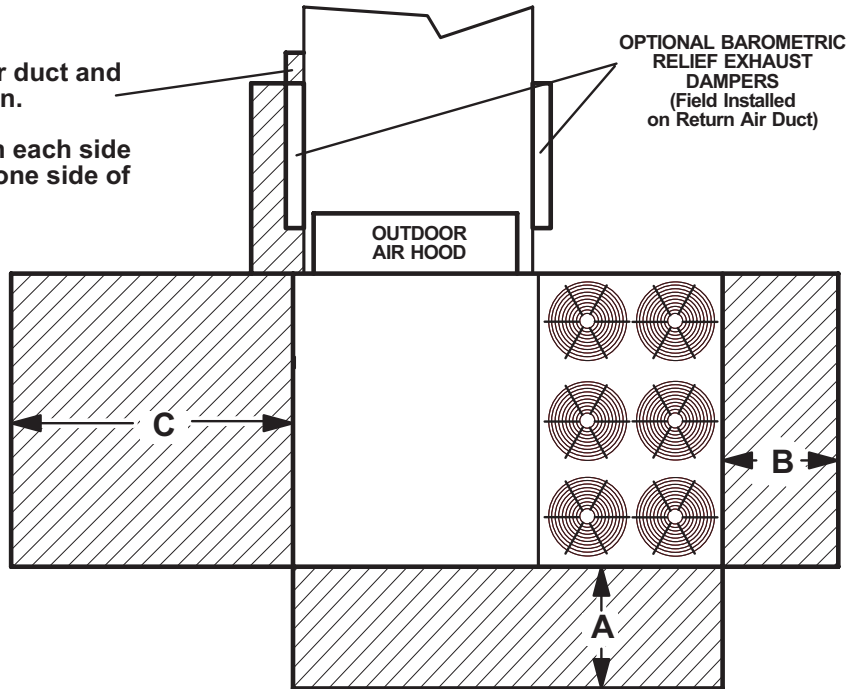

1 Unit Clearance	A		B		C		Top Clearance
	mm	in.	mm	in.	mm	in.	
Service Clearance	1524	60	914	36	1676	66	Unobstructed
Clearance to Combustibles	914	36	25	1	25	1	
Minimum Operation Clearance	1143	45	914	36	1041	41	

NOTE - Entire perimeter of unit base requires support when elevated above the mounting surface.

¹ **Service Clearance** - Required for removal of serviceable parts.

Clearance to Combustibles - Required clearance to combustible material.

Minimum Operation Clearance - Required clearance for proper unit operation.

OUTDOOR SOUND DATA

Unit Model Number	Octave Band Sound Power Levels dBA, re 10 ⁻¹² Watts Center Frequency - HZ						1 Sound Rating Number (dBA)	
	125	250	500	1000	2000	4000		8000
300/360	84	85	90	90	85	80	72	95

Note - The octave sound power data does not include tonal corrections.

¹ Sound Rating Number according to AHRI Standard 370-2001.

WEIGHT DATA

UNIT

Model Number	Net		Shipping	
	kg	lbs.	kg	lbs.
300 Base Unit	1435	3107	1505	3317
300 Max. Unit	1581	3485	1676	3695
360 Base Unit	1435	3107	1505	3317
360 Max. Unit	1581	3485	1676	3695

WEIGHT DATA

OPTIONS / ACCESSORIES

Description	Shipping Weight	
	kg	lbs.
ECONOMIZER / OUTDOOR AIR / EXHAUST		
Economizer	63	138
Barometric Relief		
Downflow Barometric Relief Dampers	20	45
Horizontal Barometric Relief Dampers	9	20
Outdoor Air Dampers		
Damper Section (downflow) Motorized - E1DAMP25D-1-	33	72
Damper Section (downflow) Manual - E1DAMO15D-1-	31	68
Outdoor Air Hood (downflow) LAOAH30/36	34	76
Power Exhaust		
	45	99
GAS HEAT EXCHANGER (NET WEIGHT)		
Medium Heat (adder over standard heat)	18	8
High Heat (adder over standard heat)	64	29
ROOF CURBS		
Hybrid Roof Curbs, Downflow		
356 mm height	52	115
457 mm height	64	140
610 mm height	77	170
Standard Curbs, Horizontal		
356 mm height	202	445
610 mm height	329	725
CEILING DIFFUSERS		
Step-Down LARTD30/36S	625	283
Flush LAFD30/36S	625	283
Transitions LASRT30/36	39	85
PACKAGING		
LTL Packaging (less than truck load)	136	300

DIMENSIONS

UNIT

Model No.	CORNER WEIGHTS								CENTER OF GRAVITY			
	AA		BB		CC		DD		EE		FF	
	kg	lbs.	kg	lbs.	kg	lbs.	kg	lbs.	mm	in.	mm	in.
LGH300 Base Unit	287	632	288	635	414	912	421	928	1524	60	940	37
LGH300 Max. Unit	322	709	323	712	464	1023	472	1041	1524	60	940	37
LGH360 Base Unit	287	632	288	635	414	912	421	928	1524	60	940	37
LGH360 Max. Unit	322	709	323	712	464	1023	472	1041	1524	60	940	37

Base Unit - The unit with NO INTERNAL OPTIONS.

Max. Unit - The unit with ALL INTERNAL OPTIONS Installed. (Economizer, Standard Static Power Exhaust Fans, Controls, etc.). Does not include accessories external to unit or high static power exhaust.

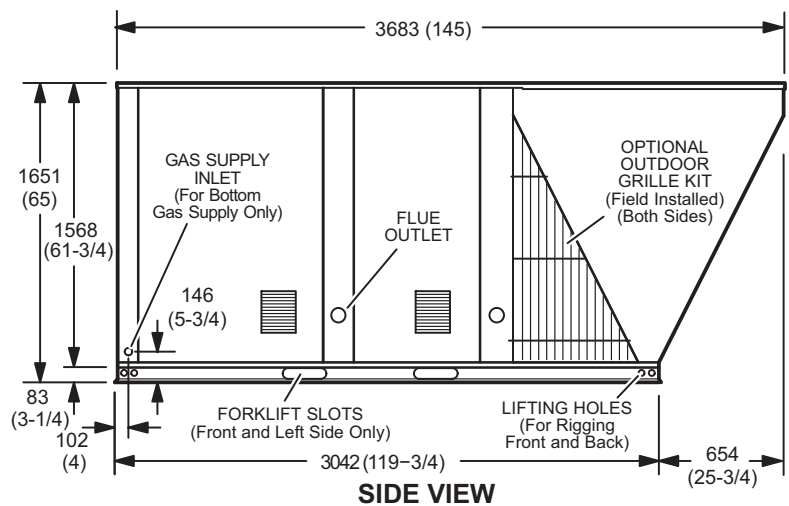
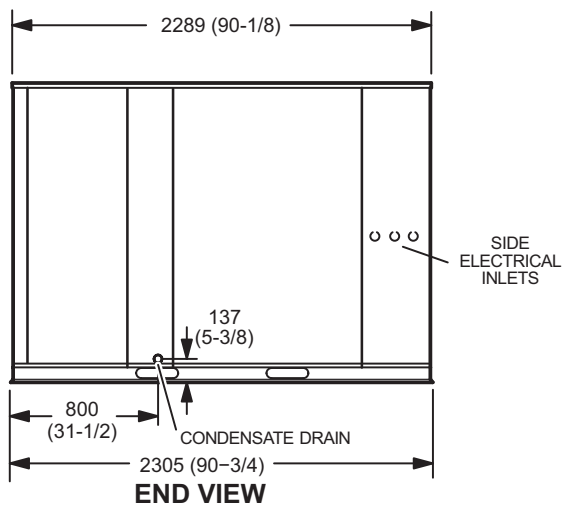
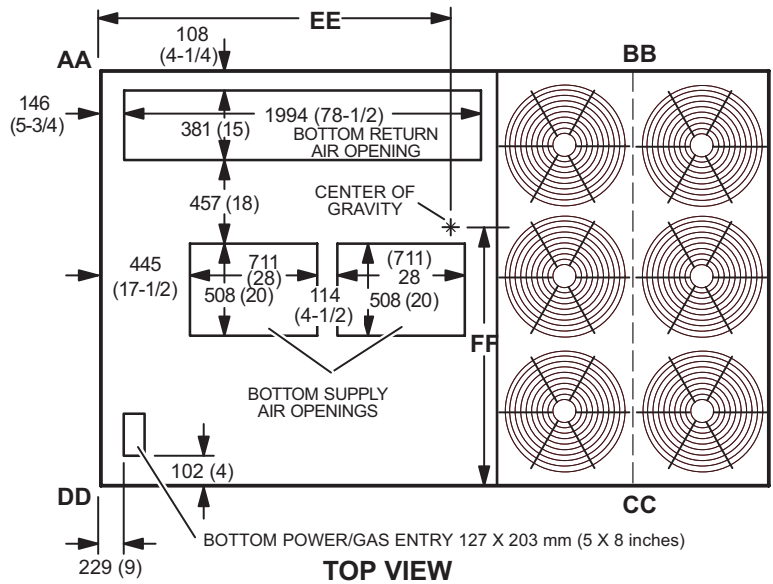

OUTDOOR AIR HOOD DETAIL

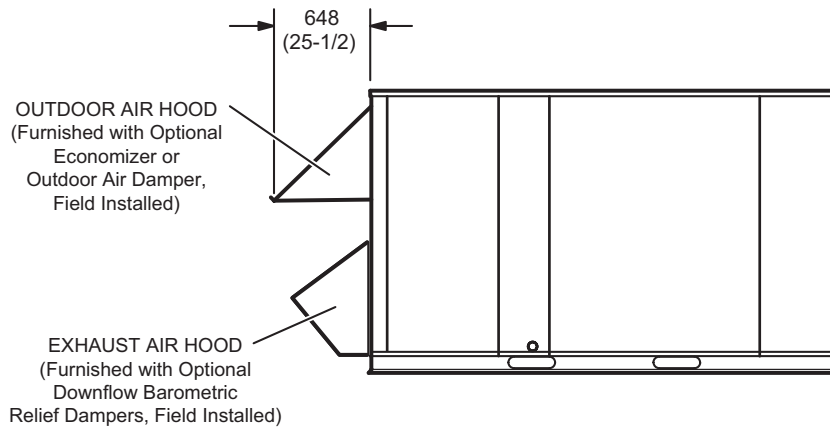

OPTIONAL HORIZONTAL BAROMETRIC RELIEF DAMPERS WITH HOOD

(Field installed in horizontal return air duct adjacent to unit)

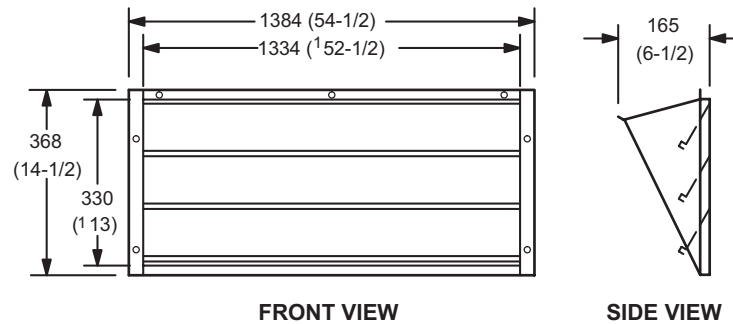

NOTE - Two furnished per order no.
 1 NOTE - Opening size required in return air duct.

HYBRID ROOF CURBS - DOUBLE DUCT OPENING

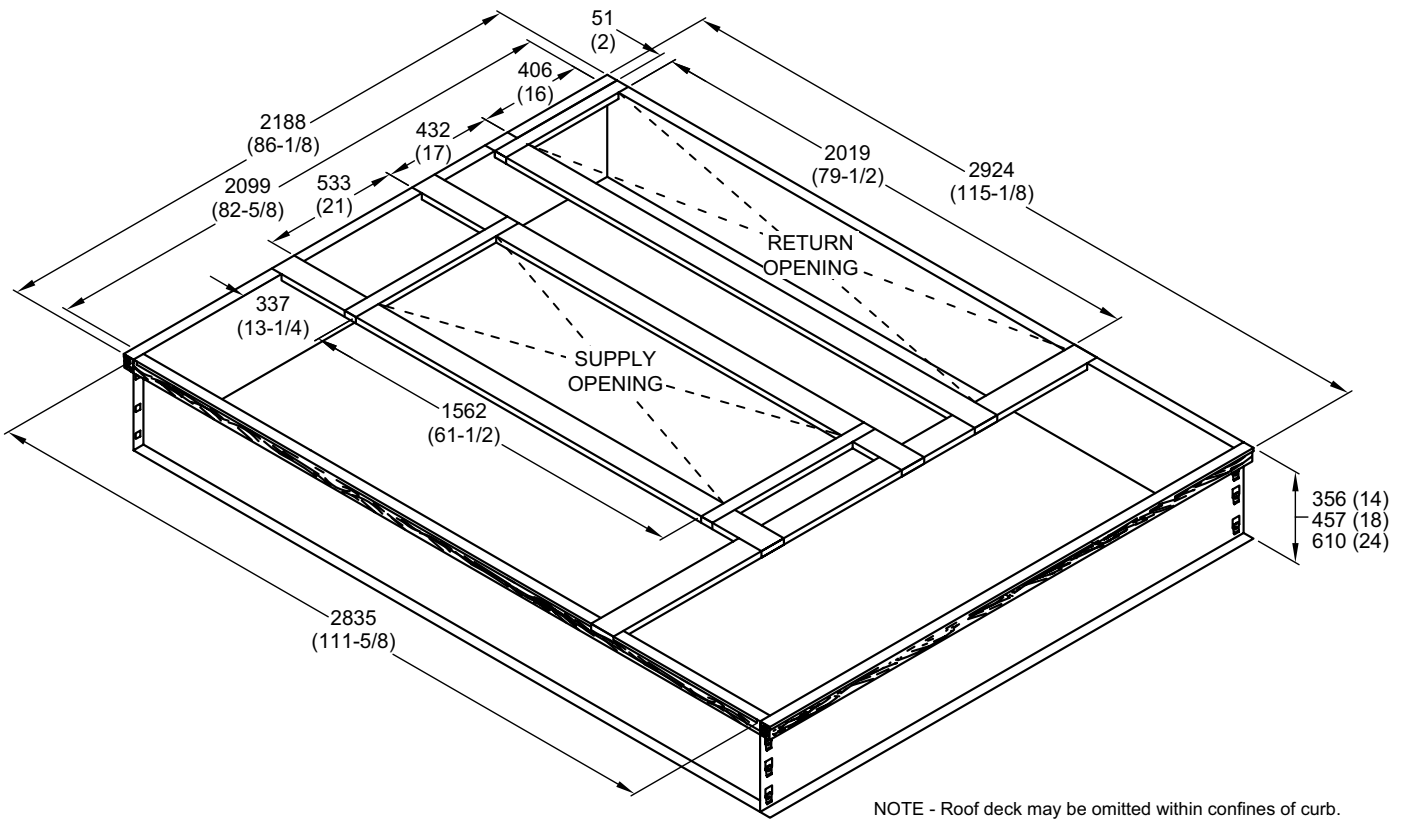

TYPICAL FLASHING DETAIL FOR ROOF CURB

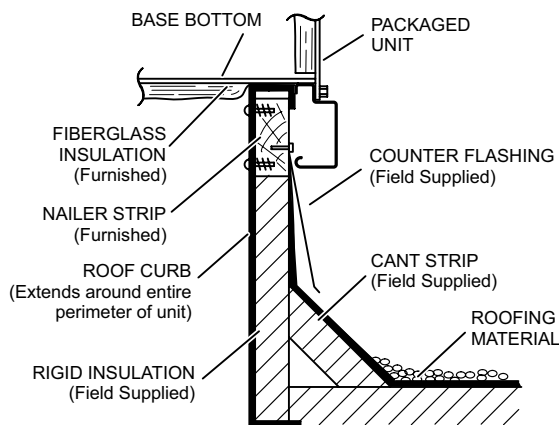

DETAIL ROOF CURB

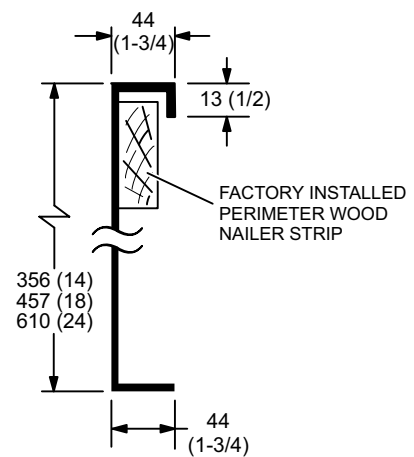

ROOF CURBS WITH SUPPLY & RETURN AIR TRANSITIONS FOR CEILING DIFFUSERS

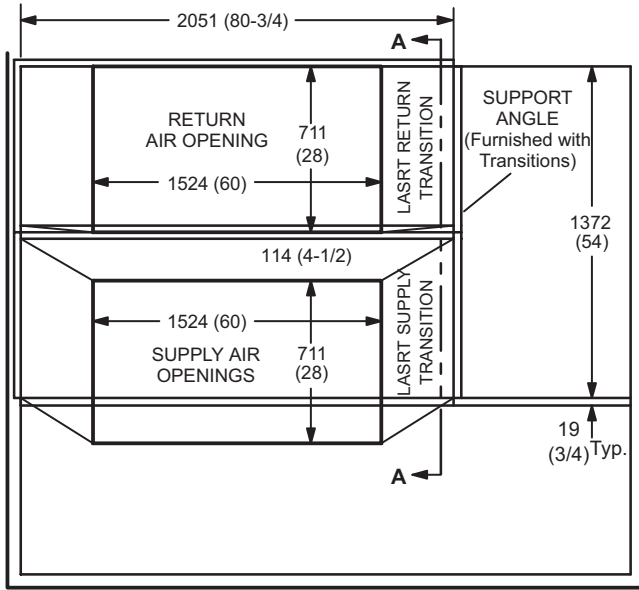

TOP VIEW

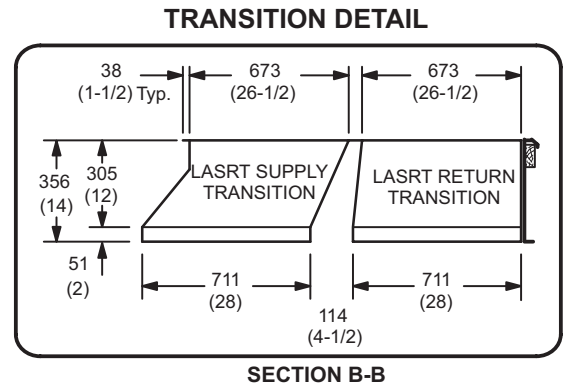

SECTION B-B

HORIZONTAL ROOF CURBS – Requires Optional Horizontal Return Air Panel Kit

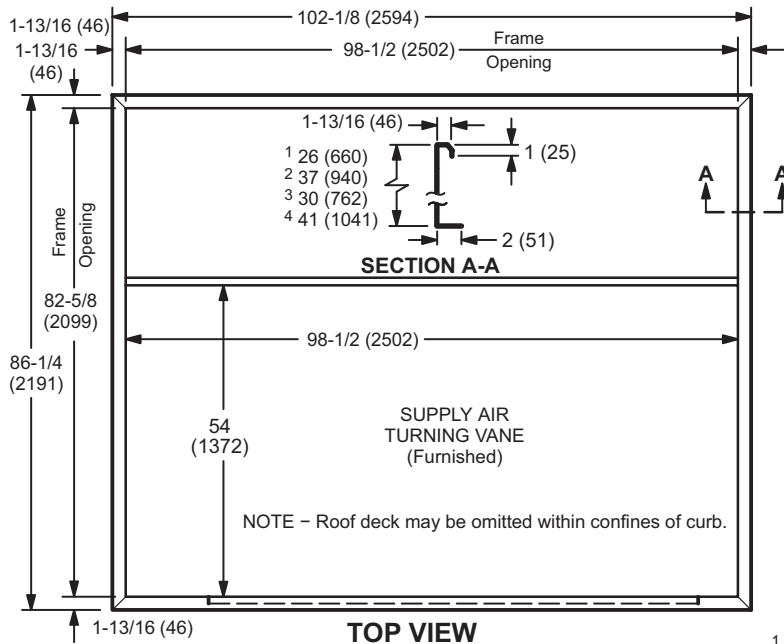

NOTE - 30 in. (762 mm) height Curb is designed for horizontal discharge when unit is mounted on a slab.
41 in. (1041 mm) height Curb is designed for horizontal discharge when unit is mounted on a rooftop.

PANEL TO COVER RETURN AIR OPENING IN BOTTOM OF UNIT
(Furnished With Optional Horizontal Return Air Panel Kit)

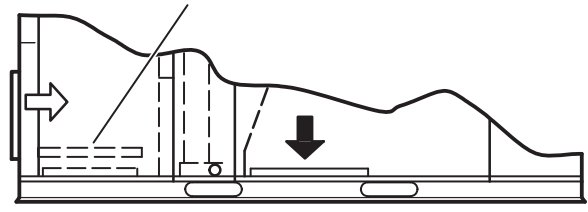

**SIDE VIEW
(PACKAGED UNIT)**

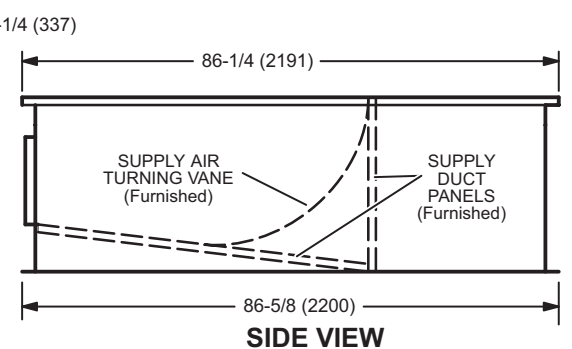
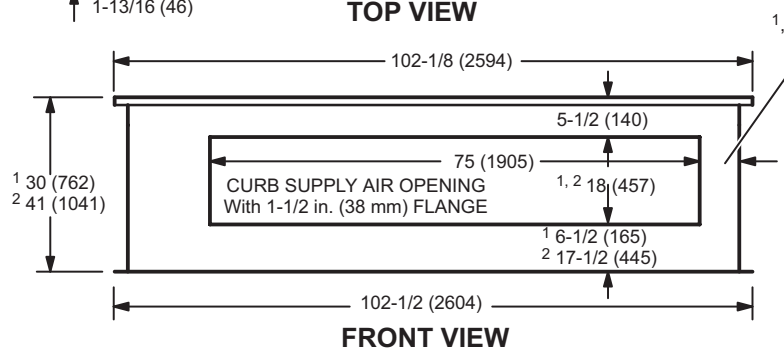

FRONT VIEW

SIDE VIEW

¹ Slab Applications ² Rooftop Applications

**HORIZONTAL SUPPLY AND RETURN AIR OPENINGS
ROOFTOP UNIT WITH HORIZONTAL ROOF CURB**

¹ Slab Applications
² Rooftop Applications

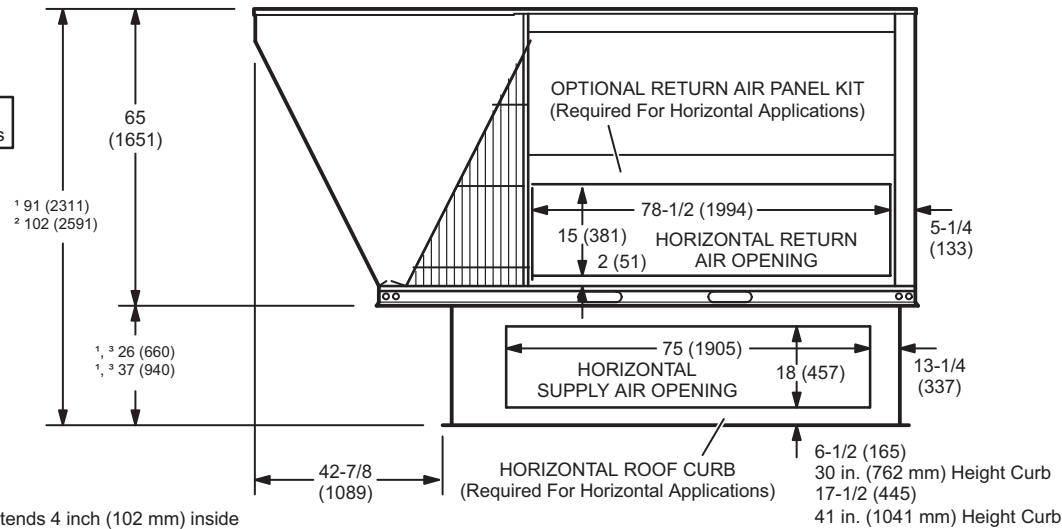

³ NOTE - Top of Curb extends 4 inch (102 mm) inside bottom of unit base. See Typical Flashing Detail.

**SIDE VIEW
(Horizontal Openings)**

COMBINATION CEILING SUPPLY AND RETURN DIFFUSERS

STEP-DOWN CEILING DIFFUSER

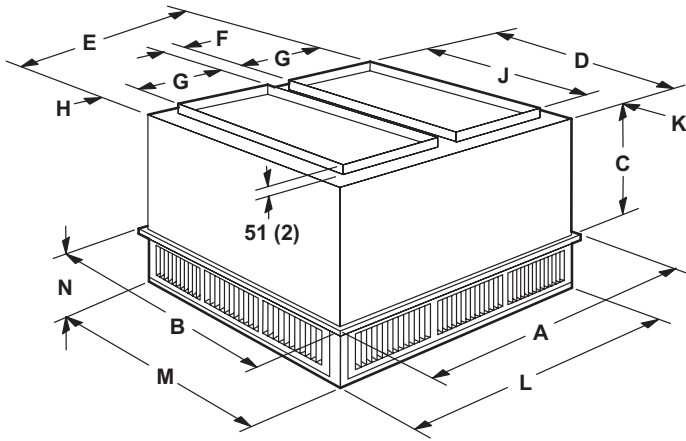

FLUSH CEILING DIFFUSER

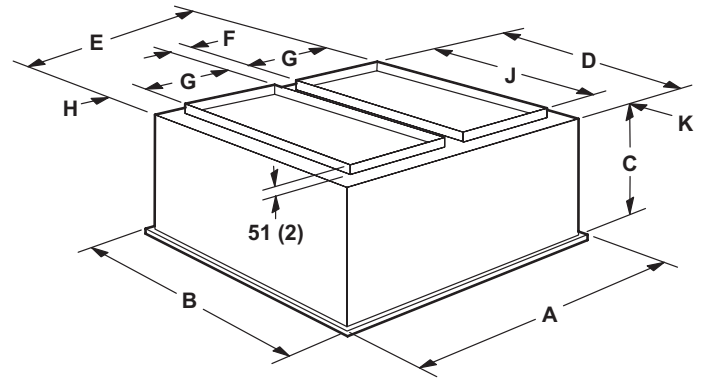

Model Number		LARTD30/36S
A	mm	1667
	in.	65-5/8
B	mm	1667
	in.	65-5/8
C	mm	1029
	in.	40-1/2
D	mm	1613
	in.	63-1/2
E	mm	1613
	in.	63-1/2
F	mm	114
	in.	4-1/2
G	mm	711
	in.	28
H	mm	38
	in.	1-1/2
J	mm	1524
	in.	60
K	mm	44
	in.	1-3/4
L	mm	1613
	in.	63-1/2
M	mm	1613
	in.	63-1/2
N	mm	308
	in.	12-1/8
Duct Size	mm	711 x 1524
	in.	28 x 60

Model Number		LAFD30/36S
A	mm	1667
	in.	65-5/8
B	mm	1667
	in.	65-5/8
C	mm	1016
	in.	40
D	mm	1613
	in.	63-1/2
E	mm	1613
	in.	63-1/2
F	mm	108
	in.	4-1/4
G	mm	711
	in.	28
H	mm	32
	in.	1-5/8
J	mm	1524
	in.	60
K	mm	44
	in.	1-3/4
Duct Size	mm	711 x 1524
	in.	28 x 60

REVISIONS

Sections	Description of Change
Options/Accessories	Catalog number revised for: LPG/Propane Conversion Kits



Visit us at www.lennox.com

For the latest technical information, www.lennoxcommercial.com

Contact us at 1-800-4-LENNOX

NOTE - Due to Lennox' ongoing commitment to quality, Specifications, Ratings and Dimensions subject to change without notice and without incurring liability. Improper installation, adjustment, alteration, service or maintenance can cause property damage or personal injury. Installation and service must be performed by a qualified installer and servicing agency.

©2021 Lennox Industries, Inc.