

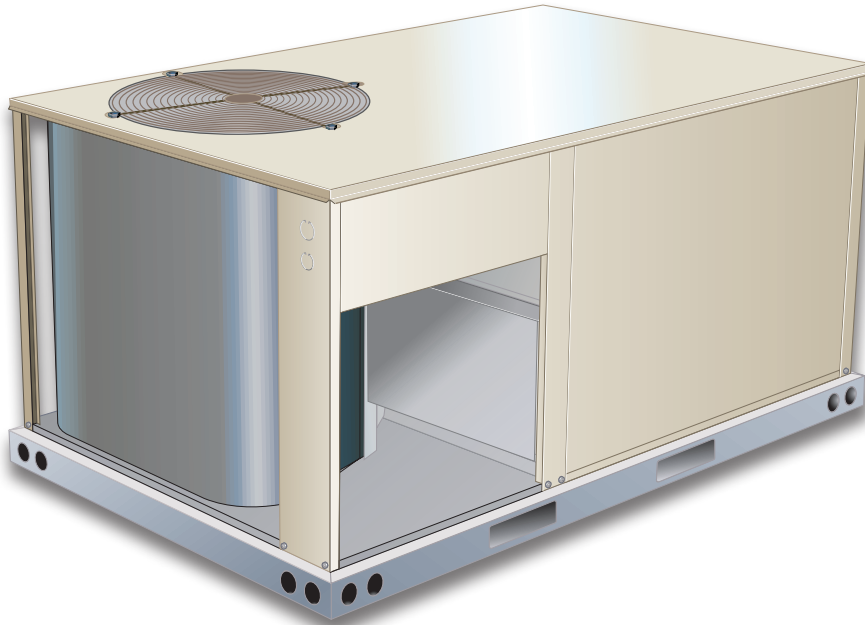

**COMMERCIAL  
PRODUCT SPECIFICATIONS**

Bulletin No. 490182  
March 2021  
Supersedes April 2019



**RAIDER®**  
Value Without Compromise®



**10.5 to 21 kW (3 to 6 Tons)**  
**Net Cooling Capacity - 8.8 to 16.9 kW (30 200 to 57 500 Btuh)**  
**Optional Electric Heat - 3.8 to 23 kW**

**MODEL NUMBER IDENTIFICATION**

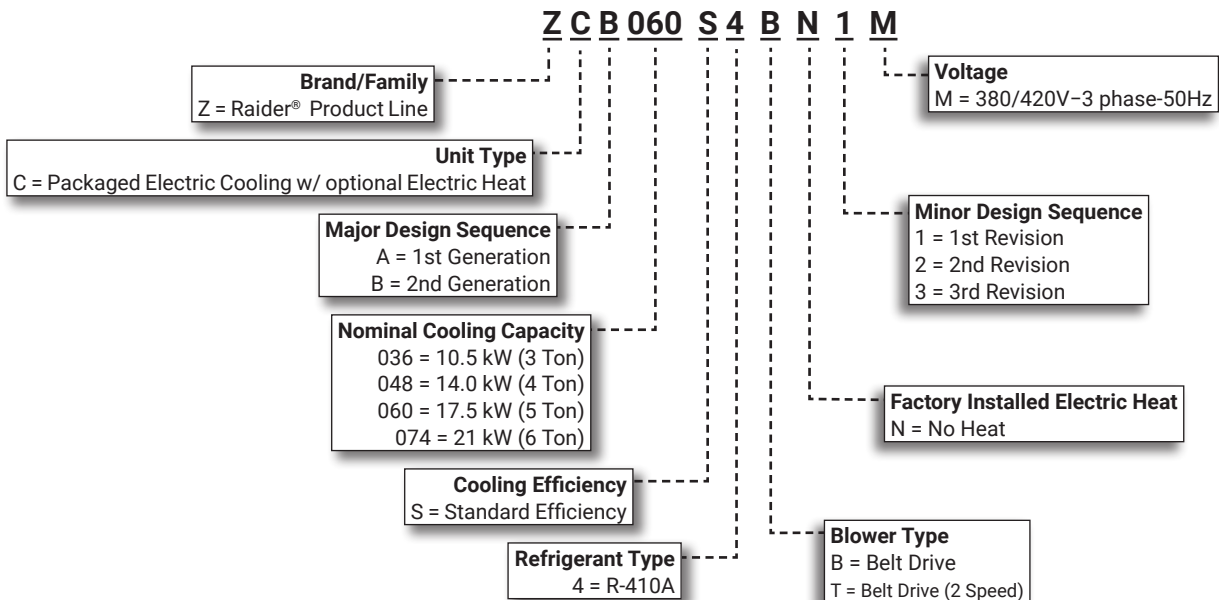

## FEATURE HIGHLIGHTS

Raider® rooftop units from Lennox are the new standard for cost efficient, reliable rooftop units built for long-lasting performance that can significantly improve indoor environments.

1. Scroll Compressor
2. Lennox' Environ™ Coil System
3. Outdoor Coil Fan Motor
4. Heavy Gauge Steel Cabinet
5. Supply Air Blower
6. Electric Heat (option)

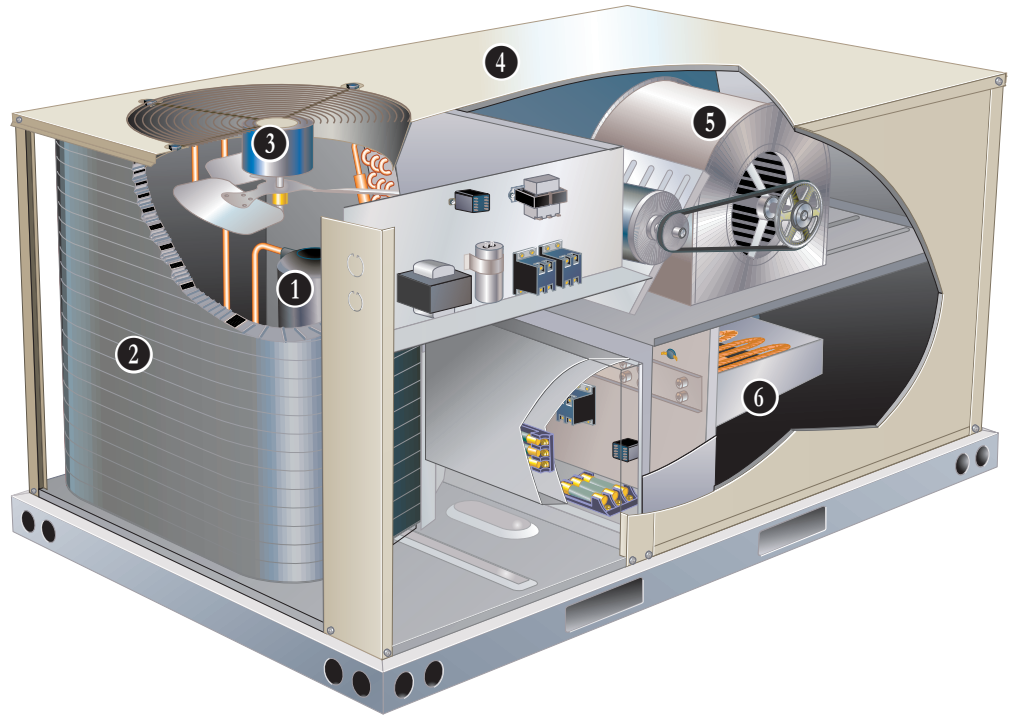

## CONTENTS

Approvals . . . . .	3
Blower Data . . . . .	17
- Belt Drive   3 Ton . . . . .	17
- Belt Drive   4 Ton . . . . .	19
- Belt Drive   5 Ton . . . . .	21
- Belt Drive   6 Ton . . . . .	23
Dimensions . . . . .	31
- Unit . . . . .	31
- Accessories . . . . .	32
Electrical Data . . . . .	27
Electric Heat Capacities . . . . .	28
Features And Benefits . . . . .	3
Model Number Identification. . . . .	1
Optional Conventional Temperature Control Systems . . . . .	8
Options / Accessories . . . . .	9
Outdoor Sound Data . . . . .	28
Ratings . . . . .	13
Specifications . . . . .	11
Unit Clearances . . . . .	29
Weight Data . . . . .	30
- Unit . . . . .	30
- Options / Accessories. . . . .	30

## APPROVALS

### PERFORMANCE / QUALITY

- Components bonded for grounding to meet safety standards for servicing required by Underwriters Laboratories (UL) and the International Electrotechnical Commission (IEC).
- Cooling performance is rated at test conditions included in Air- Conditioning, Heating and Refrigeration Institute (AHRI) Standards 210/240-2008 and 340/360-2007 while operating at rated voltage and air volumes.
- International Organization for Standardization (ISO) 9001 Registered Manufacturing Quality System.

## FEATURES AND BENEFITS

### COOLING SYSTEM

- Designed to maximize sensible and latent cooling performance at design conditions
- System can operate from 2°C to 52°C without any additional controls

#### R-410A Refrigerant

- Non-chlorine based
- Ozone friendly, R-410A
- Unit is factory pre-charged with refrigerant; see Specifications Table

#### 1 Single Speed Scroll Compressor (036 through 060)

- Resiliently mounted on rubber grommets for quiet operation
- Scroll compressors for high performance, reliability and quiet operation

#### Two-Stage Compressor (074 Models)

- Two-stage scroll compressors for increased part load efficiency, high performance, reliability and quiet operation
- Resiliently mounted on rubber grommets for quiet operation

#### Compressor Crankcase Heater

- Protects against refrigerant migration that can occur during low ambient operation

#### Thermal Expansion Valve (074 Models)

- Ensures optimal performance throughout the application range
- Removable element head

#### Refrigerant Metering Orifice (036 through 060 Models)

- Accurately meters refrigerant in system
- Refrigerant control is accomplished by exact sizing of refrigerant metering orifice

#### High Pressure Switch

- Protects the compressor from overload conditions such as dirty condenser coils, blocked refrigerant flow, or loss of outdoor fan operation
- Automatic reset

#### Filter/Drier

- High capacity filter/drier protects the system from dirt and moisture

#### 2 Lennox' Environ™ Coil System

- Lightweight, all aluminum brazed fin construction
- Constructed of three components:
  - A flat extrusion tube
  - Fins in-between the flat extrusion tube
  - Two refrigerant manifolds

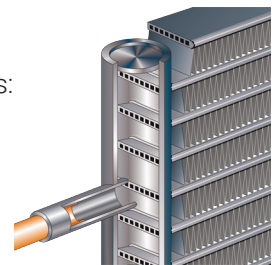

#### Environ™ Coil System Features:

- Improved heat transfer performance due to high primary surface area (flat tubes) versus secondary surface (fins)
- Smaller internal volume (reduced refrigerant charge)
- High durability (all aluminum construction)
- Fewer brazed joints
- Compact design (reduces unit weight)
- Easy maintenance/cleaning
- Face-split design
- Mounting brackets with rubber inserts secure coil to unit providing vibration dampening and corrosion protection

#### Evaporator Coil

- Copper tube construction
- Enhanced rippled-edge aluminum fins
- Flared shoulder tubing connections
- Silver soldered construction
- Factory leak tested
- Cross row circuiting with rifled tubing

#### Condensate Drain Pan

- Plastic pan, sloped to meet drainage requirements of ASHRAE 62.1
- End drain connection

## FEATURES AND BENEFITS

### COOLING SYSTEM (continued)

#### 3 Outdoor Coil Fan Motor

- Thermal overload protected
- Totally enclosed
- Permanently lubricated bearings
- Shaft down
- Fan guard mount

#### Outdoor Coil Fan Guard

- Polyvinyl chloride (PVC) coated fan guard furnished

#### Required Selections

#### Cooling Capacity

- Specify nominal cooling capacity

#### Options / Accessories

#### Field Installed

##### Condensate Drain Trap

- Available in copper or polyvinyl chloride (PVC)

##### Drain Pan Overflow Switch

- Monitors condensate level in drain pan
- Shuts down unit if drain becomes clogged

##### Low Ambient Kit

- Cycles the outdoor fans while allowing compressor operation in the cooling cycle
- Intermittent fan operation allows the system to operate without icing the evaporator coil and losing capacity
- Designed for use in ambient temperatures no lower than -18°C

**NOTE** - A crankcase heater must be installed on the compressor.

### CABINET

#### 4 Construction

- Heavy-gauge steel panels
- Full perimeter heavy-gauge galvanized steel base rail
- Base rails have rigging holes
- Three sides of the base rail have forklift slots
- Raised edges around duct and power entry openings in the bottom of the unit for water protection

#### Airflow Choice

- Units are shipped in downflow (vertical) return air flow configuration

**NOTE** - Units can be field converted to horizontal airflow.

#### Power Entry

- Electrical lines can be brought through the unit base or through horizontal access knock-outs

**NOTE** - Optional Bottom Power Entry Kit is available.

#### Exterior Panels

- Constructed of heavy-gauge, galvanized steel
- Two-layer enamel paint finish

#### Insulation

- Fully insulated with non-hygroscopic fiberglass insulation (conditioned areas)

#### Access Panels

- Compressor
- Heating
- Controls
- Blower
- Air filter/economizer section

#### Options / Accessories

### Factory Installed

#### Corrosion Protection

- Completely flexible immersed coating
- Electrodeposited dry film process (AST ElectroFin E-Coat)
- Meets Mil Spec MIL-P-53084, ASTM B117 Standard Method Salt Spray Testing
- Indoor Corrosion Protection
  - Coated coil
- Outdoor Corrosion Protection
  - Coated coil

### Field Installed

#### Combination Coil/Hail Guards

- Heavy gauge steel frame
- Painted to match cabinet
- Expanded metal mesh protects outdoor coil

### CONTROLS

#### Unit Control

- All control voltage is provided via a 24V (secondary) transformer with inline fuse protection
- **Heat/Cool Staging** - Capable of up to 1 heat / 2 cool staging with a thermostat
- **Night Setback Mode** - Saves energy by closing outdoor air dampers and operating supply fan on thermostat demand only

#### Options / Accessories

### Field Installed

#### Smoke Detectors

**NOTE** - Smoke detectors are not available and must be field provided by installer.

#### Thermostats

- Control system and thermostat options, see page 8

## FEATURES AND BENEFITS

### **BLOWER**

- A wide selection of supply air blower options are available to meet a variety of air flow requirements

#### **Motor**

- Overload protected
- Ball bearings
- Belt drive motors are offered on all models and are available in several different sizes to maximize air performance
- Two-speed belt drive motor (low static/high static) is available on 074 models

#### **Required Selections**

##### **5 Supply Air Blower**

- Forward curved blades
- Blower wheel statically and dynamically balanced
- Ball bearings
- Adjustable pulley (allows speed change)

### **ELECTRICAL**

#### **Marked & Color-Coded Wiring**

- All electrical wiring is color-coded and marked to identify which components it is connecting

#### **Electrical Plugs**

- Positive connection electrical plugs are used to connect common accessories or maintenance parts for easy removal or installation

#### **Required Selections**

##### **Voltage Choice**

- Specify when ordering base unit

##### **Field Installed**

##### **6 Electric Heat**

- Helix wound nichrome elements
- Individual element limit controls
- Wiring harness

**NOTE** - See Options / Accessories tables for ordering information.

**NOTE** - Unit Fuse Block is required and must be ordered separately. See Electrical / Electric Heat tables for ordering information.

### **INDOOR AIR QUALITY**

#### **Air Filters**

- Disposable 51 mm filters furnished as standard

#### **Options / Accessories**

##### **Field Installed**

##### **Indoor Air Quality (CO<sub>2</sub>) Sensor**

- Monitors CO<sub>2</sub> levels adjusts economizer dampers as needed for Demand Control Ventilation

## OPTIONS / ACCESSORIES

### ECONOMIZER

#### **Factory or Field Installed**

#### Economizer (Downflow or Horizontal) (Standard and High Performance Common Features)

- Outdoor Air Hood is furnished
- Includes Barometric Relief Dampers with Exhaust Hood
- Barometric Relief Dampers allow relief of excess air,
- Aluminum blade dampers prevent blow back and outdoor air infiltration during off cycle
- Exhaust hood with bird screen furnished
- Demand Control Ventilation (DCV) ready using optional CO<sub>2</sub> sensors
- Single temperature control is furnished with Economizer
- Outdoor air sensor enables Economizer if the outdoor temperature is less than the setpoint of the control

**NOTE** - Horizontal Economizer is field installed only.

#### Standard Economizer Features

- Gear-driven action
- Return air and outdoor air dampers
- Plug-in connections to unit
- Nylon bearings
- Neoprene seals
- 24-volt
- Fully-modulating spring return motor

#### Standard Economizer Control Module

The Standard Economizer Control Module can be adjusted to operate based on outdoor air temperatures



#### Economizer Controls:

- **Damper Minimum Position** - Can be set lower than traditional minimum air requirements resulting in cost savings
- **IAQ Sensor** - Signals dampers to modulate and maintain 13°C when CO<sub>2</sub> is higher than the CO<sub>2</sub> setpoint
- **Demand Control Ventilation (DCV) LED** - A steady green Demand Control Ventilation LED indicates the IAQ reading is higher than setpoint and requires more fresh air
- **Free Cool LED** - A steady green LED indicates outdoor air is suitable for free cooling

**NOTE** - Free Cooling runs when outdoor air temperature is lower than the set temperature on the economizer control.

**NOTE:** The Free Cooling default setting for outdoor air temperature sensor is 13°C.

#### High Performance Economizer Features

- Low leakage dampers are Air Movement and Control Association International (AMCA) Class 1A Certified - Maximum 3 CFM per sq. ft. leakage at 1 in. w.g.
- ASHRAE 90.1-2010 compliant
- Gear-driven action
- High torque 24-volt fully-modulating spring return damper motor
- Return air and outdoor air dampers
- Plug-in connections to unit
- Stainless steel bearings
- Enhanced thermoplastic vulcanizate (TPV) blade edge seals
- Flexible stainless steel jamb seals minimize air leakage

#### High Performance Economizer Control Module

- Module provides inputs and outputs to control economizer based on parameter settings
- Module automatically detects sensors by polling to determine which sensors are installed in system
- Module displays any alarm messages (fault detection and diagnostics) as an aid in troubleshooting
- Non-volatile memory retains parameter settings in case of power failure
- Keypad with four navigation buttons and LCD screen is furnished for setting economizer parameters
  - Menu Up/Exit (⬆) button returns to the main menu
  - Arrow Up (▲) button moves to the previous or next parameter within the selected menu
  - Arrow Down (▼) button moves to the next parameter within the selected menu
  - Select (enter) (⬅) button confirms parameter selection



## OPTIONS / ACCESSORIES

### **ECONOMIZER (continued)**

High Performance Economizer Control Module (continued)

Main Menu Structure:

- STATUS (economizer and system operation status)
- SETPOINTS (settings for various setpoint parameters)
- SYSTEM SETUP (settings/information about the system)
- ADVANCED SETUP (freeze protection, CO<sub>2</sub> settings, stage 3 delay, and additional calibration settings)
- CHECKOUT (damper positions)
- ALARMS (output signal that can be configured for remote alarm monitoring)

**NOTE** - Refer to Installation Instructions for complete setup information and menu parameters available.

### **Field Installed**

Single Enthalpy Temperature Control

- Outdoor air enthalpy sensor enables Economizer if the outdoor enthalpy is less than the setpoint of the control

### **EXHAUST**

#### **Field Installed**

Power Exhaust Fan - Downflow or Horizontal

- Installs external to unit for applications with Economizer option
- Provides exhaust air pressure relief
- Interlocked to run when supply air blower is operating
- Fan runs when outdoor air dampers are 50% open (adjustable)
- Motor is overload protected
- Fan is 305 mm diameter
- Five fan blades
- 0.25 kW motor

### **OUTDOOR AIR**

#### **Field Installed**

Outdoor Air Dampers - Downflow

- Single blade damper
- 0 to 25% (fixed) outdoor air adjustable
- Installs in unit
- Automatic model features fully modulating spring return damper motor with plug-in connection
- Manual model features a slide damper

**NOTE** - Manual model features a slide damper. Maximum mixed air temperature in cooling mode: 38°C.

### **ROOF CURBS**

#### **Field Installed**

Hybrid Roof Curbs, Downflow

- Nailers strip furnished; mates to unit
- US National Roofing Contractors approved
- Shipped knocked down
- Interlocking tabs fasten corners together; no tools required
- Can also be fastened together with furnished hardware
- Available in 203, 356, 457, and 610 mm heights

Adaptor Curbs (not shown)

- Curbs are regionally sourced
- Dimensions will vary based upon the source

**NOTE** - Contact your local sales representative for a detailed cut sheet with applicable dimensions.

### **CEILING DIFFUSERS**

#### **Field Installed**

- Flush or Step-Down
- White powder coat finish on diffuser face and grilles
- Insulated UL listed duct liner
- Diffuser box has collars for duct connection
- Step-down diffusers have double deflection blades
- Flush diffusers have fixed blades
- Provisions for suspending
- Internally sealed to prevent recirculation
- Removable return air grille
- Adapts to T-bar ceiling grids or plaster ceilings

Transitions (Supply and Return)

**NOTE** - Ceiling Diffuser Transitions are not furnished and must be field fabricated.

## OPTIONAL CONVENTIONAL TEMPERATURE CONTROL SYSTEMS

### ComfortSense® 7500 Commercial 7-Day Programmable Thermostat



- Four-Stage Heating / Two-Stage Cooling
- Universal Multi-Stage
- Intuitive Touchscreen Interface
- Automatic Changeover between Heating and Cooling
- Full Seven-Day Programming
- Four Time Periods Per Day
- Temperature and Humidity Control
- One-Touch Away Mode
- Holiday Scheduling
- Smooth Setback Recovery (SSR)
- Performance Reports
- Notifications/Reminders
- Economizer Relay Control
- Backlit Display
- Wallplate Furnished
- FDD, ASHRAE and IECC Compliant

### ComfortSense® 3000 Commercial 5-2 Day Programmable Thermostat

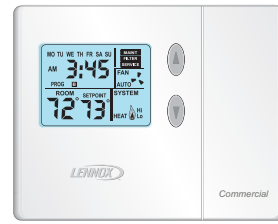

- Two-Stage Heating / Two-Stage Cooling
- Conventional Systems
- Intuitive Interface
- 5-2 Day Programming
- Program Hold
- Remote Indoor Temperature Sensing
- Smooth Setback Recovery (SSR)
- Economizer Relay Control
- Maintenance/Filter/Service Reminders
- Backlit Display
- Wallplate Furnished
- Simple Up and Down Temperature Control

Description	Model No.	Catalog No.
<b>ComfortSense® 7500 7-Day Programmable</b>	C0STAT06FF2L	<b>17G74</b>
Universal thermostat locking guard (clear)	C0MISC15AE1-	<b>39P21</b>
<b>Temperature Sensors</b>	<sup>1</sup> Remote non-adjustable wall-mount 20k	<b>47W36</b>
	<sup>1</sup> Remote non-adjustable wall-mount 10k	<b>47W37</b>
	Remote non-adjustable discharge air (duct mount)	<b>19L22</b>
	Outdoor temperature sensor	<b>X2658</b>
<sup>1</sup> Remote wall-mount sensors can be applied in any of the following combinations: One Sensor - (1) 47W36, Two Sensors - (2) 47W37, Three Sensors - (2) 47W36 and (1) 47W37 Four Sensors - (4) 47W36, Five Sensors - (3) 47W36 and (2) 47W37		
<b>ComfortSense® 3000 5-2 Day Programmable</b>	C0STAT05FF1L	<b>11Y05</b>
Thermostat wall mounting plate	C0MISC17AE1-	<b>X2659</b>
<b>Temperature Sensor</b>	Remote non-adjustable wall mount 10k averaging	<b>47W37</b>
<b>BACnet Controls</b>	7-Day BACnet Thermostat	<b>Y8241</b>
	BACnet Module (factory or field)	<b>K0CTRL31A-2</b>
<sup>2</sup> <b>BACnet Room Sensors</b>	With Display	<b>K0SNSR01FF1</b>
	Without Display	<b>K0SNSR00FF1</b>

<sup>2</sup> Only compatible with BACnet Module (16X70).

### BACnet Compatible Thermostat With Reheat Function



- 7-Day Programmable
- BTL listed MS/TP ensures compatibility with any BACnet system
- Built-in control programs for conventional and heat pump applications
- Conventional systems up to 3-stage heat and 3-stage cool
- Heat pumps with 1 or 2 compressors and up to 2-stage auxiliary heat
- On-board temperature and humidity sensor
- Multiple configurable inputs and outputs enable advanced control strategies
- Set-up Wizard enables rapid system configuration
- No special tools required for installation or commissioning
- Seven-day (2, 4 or 6 event) occupancy scheduling per day
- Backlit 5-inch LCD touchscreen



## OPTIONS / ACCESSORIES

Item		Catalog No.	ZCB 036	ZCB 048	ZCB 060	ZCB 074
<b>COOLING SYSTEM</b>						
Condensate Drain Trap	Polyvinyl Chloride (PVC) - C1TRAP20AD2	<b>22H54</b>	X	X	X	X
	Copper - C1TRAP10AD2	<b>76W27</b>	X	X	X	X
Drain Pan Overflow Switch	Z1SNSR90A1	<b>99W59</b>	X	X	X	X
Low Ambient Kit	Z1SNSR33A-1	<b>99W67</b>	X	X	X	X
<b>BLOWER - SUPPLY AIR</b>						
Motors	Belt Drive - 0.62 kW Standard Efficiency	Factory	O	O		
	Belt Drive - 0.93 kW Standard Efficiency	Factory	O	O	O	
	Belt Drive - 1.24 kW Standard Efficiency	Factory			O	O
	Belt Drive - 1.24 kW (2 Speed)	Factory				O
Drive Kits See Blower Data Tables for selection	Kit #ZA07 - 705-1077 rev/min	Factory	O			
	Kit #ZA08 - 759-1158 rev/min	Factory		O		
	Kit #ZA09 - 919-1247 rev/min	Factory			O	
	Kit #ZA10 - 1025-1391 rev/min	Factory	O			
	<sup>1</sup> Kit #ZA11 - 1111-1437 rev/min	Factory		O		
	<sup>2</sup> Kit #ZA12 - 1190-1540 rev/min	Factory			O	
	Kit #ZAA03 - 665-921 rev/min	Factory				O
	Kit #ZAA04 - 768-1023 rev/min	Factory				O
Kit #ZAA05 - 921-1177 rev/min	Factory				O	
<b>CABINET</b>						
Combination Coil/Hail Guards	Z1GARD52A-1	<b>12X19</b>	X	X		
	Z1GARD52AT1	<b>12X20</b>			X	X
Corrosion Protection		Factory	O	O	O	O
<b>ELECTRICAL</b>						
Voltage 50 hz with neutral	380/420V - 3 phase	Factory	O	O	O	O
Bottom Power Entry Kit	Z1PEKT01A-1	<b>98W08</b>	X	X	X	X
<b><sup>3</sup> ELECTRIC HEAT</b>						
3.8 kW	380/420V-3ph - Z1EH0050AN1G	<b>99W06</b>	X	X	X	O
5.7 kW	380/420V-3ph - Z1EH0075AN1G	<b>99W07</b>	X	X	X	X
7.7 kW	380/420V-3ph - Z1EH0100AN1G	<b>99W08</b>	X	X	X	X
11.5 kW	380/420V-3ph - Z1EH0150AN1G	<b>99W09</b>	X	X	X	X
17.2 kW	380/420V-3ph - Z1EH0225AN1G	<b>99W10</b>		X	X	X
23 kW	380/420V-3ph - Z1EH0300A-1G	<b>13U02</b>				X
<b>ELECTRIC HEAT ACCESSORIES</b>						
Unit Fuse Block (required) - See Electrical/Electric Heat Tables for Selection			X	X	X	X

<sup>1</sup> ZA11 drive kits require the 0.93 kW motor.

<sup>2</sup> ZA12 drive kit requires the 1.24 kW motor.

<sup>3</sup> Nominal kW at 420V-3ph-50hz.

NOTE - The catalog and model numbers that appear here are for ordering field installed accessories only.

OX - Field Installed or Configure to Order (factory installed)

O - Configure to Order (Factory Installed)

X - Field Installed.

## OPTIONS / ACCESSORIES

Item	Catalog No.	ZCB 036	ZCB 048	ZCB 060	ZCB 074
<b>ECONOMIZER</b>					
<b>Standard Economizer With Outdoor Air Hood</b>					
Standard Economizer (Downflow) Includes Barometric Relief Dampers and Exhaust Hood	Z1ECON30A-2	14D94	OX	OX	OX
Standard Economizer (Horizontal) Includes Barometric Relief Dampers and Exhaust Hood	Z1ECON16A-2	14D92	X	X	X
<b>Standard Economizer Controls</b>					
Single Enthalpy Control	C1SNSR64FF1	21Z09	X	X	X
<b>High Performance Economizer With Outdoor Air Hood</b>					
High Performance Economizer (Downflow) Includes Barometric Relief Dampers and Exhaust Hood	Z1ECON32A-4	20V23	OX	OX	OX
High Performance Economizer (Horizontal) Includes Barometric Relief Dampers and Exhaust Hood	Z1ECON33A-4	20V24	X	X	X
<b>High Performance Economizer Controls</b>					
Single Enthalpy Control	C1SNSR61FF1	11G21	X	X	X
<b>OUTDOOR AIR</b>					
<b>Outdoor Air Dampers With Outdoor Air Hood</b>					
Motorized	Z1DAMP21A-2	15D19	X	X	X
Manual	Z1DAMP11A-2	15D20	X	X	X
<b>Power EXhaust FAN</b>					
Standard Static (Downflow)	380/420V-3ph - Z1PWRE10A-1G	23E01	X	X	X
Standard Static (Horizontal)	380/420V-3ph - Z1PWRE15A-1G	28E01	X	X	X
<b>Indoor Air Quality</b>					
<b>Indoor Air Quality (CO<sub>2</sub>) Sensors</b>					
Sensor - Wall-mount, off-white plastic cover with LCD display	C0SNSR50AE1L	77N39	X	X	X
Sensor - Wall-mount, black plastic case, no display, rated for plenum mounting	C0SNSR53AE1L	87N54	X	X	X
CO <sub>2</sub> Sensor Duct Mounting Kit - for downflow applications	C0MISC19AE1	85L43	X	X	X
Aspiration Box - for duct mounting non-plenum rated CO <sub>2</sub> sensor (77N39)	C0MISC16AE1	90N43	X	X	X
<b>ROOF CURBS</b>					
<b>Hybrid Roof Curbs, Downflow</b>					
203 mm height	Z1CURB70A-1	11F76	X	X	X
356 mm height	Z1CURB71A-1	11F77	X	X	X
457 mm height	Z1CURB72A-1	11F78	X	X	X
610 mm height	Z1CURB73A-1	11F79	X	X	X
<b>CEILING DIFFUSERS</b>					
Step-Down - Order one	RTD9-65S	13K60	X	X	X
	RTD11-95S	13K61			X
Flush - Order one	FD9-65S	13K55	X	X	X
	FD11-95S	13K56			X

NOTE - Ceiling Diffuser Transitions are not furnished and must be field fabricated.

NOTE - The catalog and model numbers that appear here are for ordering field installed accessories only.

OX - Field Installed or Configure to Order (factory installed)

O - Configure to Order (Factory Installed)

X - Field Installed.

## SPECIFICATIONS

General Data		Nominal Size	10.5 kW (3 Ton)	14.0 kW (4 Ton)	17.5 kW (5 Ton)
		Model No.	ZCB036S4B	ZCB048S4B	ZCB060S4B
		Efficiency Type	Standard	Standard	Standard
		Blower Type	Single Speed Belt Drive	Single Speed Belt Drive	Single Speed Belt Drive
<b>Cooling Performance</b>	Gross Cooling Capacity - kW (Btuh)		9.2 (31 400)	12.0 (40 900)	14.6 (49 900)
	<sup>1</sup> Net Cooling Capacity - kW (Btuh)		8.8 (30 200)	11.6 (39 700)	14.2 (48 600)
	Rated Air Flow - L/s (cfm)		560 (1190)	650 (1380)	815 (1725)
	<sup>3</sup> Sound Rating Number (SRN)(dBA)		77	80	78
	Total Unit Power - kW		2.55	3.5	4.3
	<sup>1</sup> SEER (Btuh/Watt)		14.0	14.0	14.0
	<sup>1</sup> EER (Btuh/Watt) at 35°C (95°F)		<sup>1</sup> 11.8	<sup>1</sup> 11.3	<sup>1</sup> 11.3
	<sup>2</sup> EER (Btuh/Watt) at 46°C (115°F)		8.6	8.2	7.3
<b>Refrigerant</b>	Type		R-410A	R-410A	R-410A
	Charge Furnished		2.32 kg (5 lbs. 2 oz.)	2.38 kg (5 lbs. 4 oz.)	3.32 kg (7 lbs. 5 oz.)
<b>Electric Heat Available - See page 9</b>			3.8, 5.7, 7.7, 11.5 kW	3.8, 5.7, 7.7, 11.5, 17.2 kW	
<b>Compressor Type (one per unit)</b>			Scroll	Scroll	Scroll
<b>Outdoor Coil</b>	Net face area - m <sup>2</sup> (sq. ft.)		1.4 (15.2)	1.4 (15.2)	1.84 (19.9)
	Number of rows		1	1	1
	Fins per meter (in.)		906 (23)	906 (23)	906 (23)
<b>Outdoor Coil Fan</b>	Motor W (HP)		187 (1/4)	187 (1/4)	187 (1/4)
	Motor rev/min		690	690	690
	Total motor watts		260	260	260
	Diameter - mm (in.)		559 (22)	559 (22)	559 (22)
	Number of blades		4	4	4
	Total air volume - L/s (cfm)		1454 (3080)	1454 (3080)	1454 (3080)
<b>Indoor Coil</b>	Net face area - m <sup>2</sup> (sq. ft.)		0.78 (8.4)	0.78 (8.4)	1.0 (10.8)
	Tube diameter - mm (in.)		9.5 (3/8)	9.5 (3/8)	9.5 (3/8)
	Number of rows		3	3	3
	Fins per m (in.)		551 (14)	551 (14)	551 (14)
	Drain Connection (no. and size) -cm (in.)		(1) 1 NPT	(1) 1 NPT	(1) 1 NPT
	Expansion device type		Fixed Orifice	Fixed Orifice	Fixed Orifice
<sup>4</sup> <b>Indoor Blower &amp; Drive Selection</b>	Nominal Motor kW (hp)		0.62 (0.83)	0.62 (0.83)	0.93 (1.25)
			0.93 (1.25)	0.93 (1.25)	1.24 (1.66)
	Maximum Usable Motor kW (hp)		0.71 (0.95)	0.71 (0.95)	1.07 (1.43)
			1.07 (1.43)	1.07 (1.43)	1.42 (1.91)
	Available Drive Kits		ZA07 705-1077 rev/min ZA10 1025-1391 rev/min	ZA08 759-1158 rev/min <sup>5</sup> ZA11 1111-1437 rev/min	ZA09 919-1247 rev/min <sup>6</sup> ZA12 1190-1540 rev/min
	Wheel nominal diameter x width - mm (in.)		254 x 254 (10 x 10)	254 x 254 (10 x 10)	254 x 254 (10 x 10)
<b>Filters</b>	Type		Disposable		
	Number and size - mm (in.)		(4) 356 x 508 x 51 (14 x 20 x 2)		(2) 406 x 508 x 51 (16 x 20 x 2) (2) 508 x 508 x 51 (20 x 20 x 2)
<b>Electrical Characteristics - 50 Hz</b>			380/420V - 50 hertz - 3 phase with neutral		

NOTE - Net capacity includes evaporator blower motor heat deduction. Gross capacity does not include evaporator blower motor heat deduction.

<sup>1</sup> Tested at conditions included in AHRI Standard 210/240; 35°C (95°F) outdoor air temperature and 27°C (80°F) dry bulb /19°C (67°F) wet bulb entering evaporator air; minimum external duct static pressure while operating at rated voltage and air volumes.

<sup>2</sup> Rated at 46°C (115°F) outdoor air temperature and 27°C (80°F) db/19°C (67°F) wb entering evaporator air (T3 Conditions).

<sup>3</sup> Sound Rating Number (SRN) rated in accordance with test conditions included in ANSI/AHRI Standard 270-2008.

<sup>4</sup> Using total air volume and system static pressure requirements determine from blower performance tables rev/min and motor size required. Maximum usable size of motors furnished is shown. If motors of comparable size are used, be sure to keep within the service factor limitations outlined on the motor nameplate.

0.62 kW = 0.83 hp (1.0 nominal hp) while operating at rated voltage and frequency.

0.93 kW = 1.25 hp (1.5 nominal hp) while operating at rated voltage and frequency.

1.24 kW = 1.66 hp (2.0 nominal hp) while operating at rated voltage and frequency.

<sup>5</sup> ZA11 drive kits require the 0.93 kW motor.

<sup>6</sup> ZA12 drive kit requires the 1.24 kW motor.

## SPECIFICATIONS

General Data		Nominal Size	21 kW (6 Ton)	21 kW (6 Ton)	
		Model No.	ZCB074S4T	ZCB074S4B	
		Efficiency Type	Standard	Standard	
		Blower Type	Two Speed Belt Drive	Single Speed Belt Drive	
<b>Cooling Performance</b>	Gross Cooling Capacity - kW (Btuh)		17.3 (59 000)	17.3 (59 000)	
	<sup>1</sup> Net Cooling Capacity - kW (Btuh)		16.9 (57 500)	16.9 (57 500)	
	Rated Air Flow - L/s (cfm)		1038 (2200)	1038 (2200)	
	<sup>3</sup> Sound Rating Number (SRN)(dBA)		84	84	
	Total Unit Power - kW		5.1	5.1	
	<sup>1</sup> IEER (Btuh/Watt)		15.0	13.0	
	<sup>1</sup> EER (Btuh/Watt) at 35°C (95°F)		11.3	11.3	
<sup>2</sup> EER (Btuh/Watt) at 46°C (115°F)		7.7	7.7		
<b>Refrigerant</b>	Type		R-410A	R-410A	
	Charge Furnished		3.26 kg (7 lbs. 3 oz.)	3.26 kg (7 lbs. 3 oz.)	
<b>Electric Heat Available - See page 9</b>			5.7, 7.7, 11.5, 17.2, 23 kW		
<b>Compressor Type (one per unit)</b>			Scroll	Scroll	
<b>Outdoor Coil</b>	Net face area - m <sup>2</sup> (sq. ft.)		1.85 (19.9)	1.85 (19.9)	
	Number of rows		1	1	
	Fins per meter (in.)		906 (23)	906 (23)	
<b>Outdoor Coil Fan</b>	Motor W (HP)		249 (1/3)	249 (1/3)	
	Motor rev/min		900	900	
	Total motor watts		290	290	
	Diameter - mm (in.)		559 (22)	559 (22)	
	Number of blades		3	3	
	Total air volume - L/s (cfm)		1680 (3560)	1680 (3560)	
	<b>Indoor Coil</b>	Net face area - m <sup>2</sup> (sq. ft.)		1.0 (10.8)	1.0 (10.8)
	Tube diameter - mm (in.)		9.5 (3/8)	9.5 (3/8)	
	Number of rows		3	3	
	Fins per m (in.)		551 (14)	551 (14)	
	Drain Connection (no. and size) -cm (in.)		(1) 1 NPT	(1) 1 NPT	
	Expansion device type		Balance port TXV, removable head		
<sup>4</sup> <b>Indoor Blower &amp; Drive Selection</b>	Nominal Motor kW (hp)		1.24 (1.66)	1.24 (1.66)	
	Maximum Usable Motor kW (hp)		1.42 (1.91)	1.42 (1.91)	
	Available Drive Kits	ZAA03		ZAA03	ZAA03
		665-921 rev/min		665-921 rev/min	665-921 rev/min
		ZAA04		ZAA04	ZAA04
		768-1023 rev/min		768-1023 rev/min	768-1023 rev/min
	ZAA05		ZAA05	ZAA05	
921-1177 rev/min		921-1177 rev/min	921-1177 rev/min		
Wheel nominal diameter x width - mm (in.)		381 x 229 (15 x 9)	381 x 229 (15 x 9)		
<b>Filters</b>	Type		Disposable		
	Number and size - mm (in.)		(2) 406 x 508 x 51 (16 x 20 x 2)		
			(2) 508 x 508 x 51 (20 x 20 x 2)		
<b>Electrical Characteristics - 50 Hz</b>			380/420V - 50 hertz - 3 phase with neutral		

NOTE - Net capacity includes evaporator blower motor heat deduction. Gross capacity does not include evaporator blower motor heat deduction.

<sup>1</sup> Rating test conditions are those included in Air-Conditioning, Heating and Refrigeration Institute (AHRI) Standard 340/360; 35°C (95°F) outdoor air temperature and 27°C (80°F) db/19°C (67°F) wb entering evaporator air; minimum external duct static pressure while operating at rated voltage and air volumes.

<sup>2</sup> Rated at 46°C (115°F) outdoor air temperature and 27°C (80°F) db/19°C (67°F) wb entering evaporator air (T3 Conditions).

<sup>3</sup> Sound Rating Number (SRN) rated in accordance with test conditions included in ANSI/AHRI Standard 270-2008.

<sup>4</sup> Using total air volume and system static pressure requirements determine from blower performance tables rev/min and motor size required. Maximum usable size of motors furnished is shown. If motors of comparable size are used, be sure to keep within the service factor limitations outlined on the motor nameplate.

0.62 kW = 0.83 hp (1.0 nominal hp) while operating at rated voltage and frequency.

0.93 kW = 1.25 hp (1.5 nominal hp) while operating at rated voltage and frequency.

1.24 kW = 1.66 hp (2.0 nominal hp) while operating at rated voltage and frequency.

# RATINGS

NOTE – For Temperatures and Capacities not shown in tables, see bulletin – Cooling Unit Rating Table Correction Factor Data in Miscellaneous Engineering Data section.

## 10.5 KW - ZCB036S4

Entering Wet Bulb Temperature	Total Air Volume	Outdoor Air Temperature Entering Outdoor Coil																							
		26.7°C						35°C						43.3°C						46°C					
		Total Cool Cap.	Comp. Motor Input	Sensible To Total Ratio (S/T)			Total Cool Cap.	Comp. Motor Input	Sensible To Total Ratio (S/T)			Total Cool Cap.	Comp. Motor Input	Sensible To Total Ratio (S/T)			Total Cool Cap.	Comp. Motor Input	Sensible To Total Ratio (S/T)						
				Dry Bulb					Dry Bulb					Dry Bulb					Dry Bulb						
L/s	kW	kW	24°C	27°C	29°C	kW	kW	24°C	27°C	29°C	kW	kW	24°C	27°C	29°C	kW	kW	24°C	27°C	29°C					
17.2°C	455	9.1	1.62	.73	.89	1.00	8.3	1.92	.75	.94	1.00	7.4	2.29	.79	.99	1.00	7.1	2.43	.84	1.00	1.00				
	565	9.6	1.62	.79	.99	1.00	8.8	1.93	.82	1.00	1.00	7.9	2.30	.88	1.00	1.00	7.6	2.44	.92	1.00	1.00				
	680	10.0	1.63	.86	1.00	1.00	9.2	1.94	.91	1.00	1.00	8.3	2.31	.97	1.00	1.00	8.0	2.45	.99	1.00	1.00				
19.4°C	455	9.6	1.63	.57	.71	.85	8.8	1.93	.58	.73	.90	7.9	2.30	.60	.77	.96	7.5	2.44	.62	.81	.98				
	565	10.1	1.63	.61	.77	.95	9.2	1.94	.62	.80	1.00	8.1	2.31	.65	.86	1.00	7.8	2.45	.68	.90	1.00				
	680	10.4	1.64	.65	.83	1.00	9.5	1.94	.67	.88	1.00	8.4	2.31	.69	.95	1.00	8.0	2.45	.73	.98	1.00				
21.7°C	455	10.2	1.64	.43	.56	.69	9.3	1.94	.43	.57	.71	8.3	2.31	.43	.59	.74	7.9	2.45	.43	.61	.78				
	565	10.7	1.65	.44	.60	.75	9.7	1.95	.45	.62	.78	8.6	2.31	.45	.64	.83	8.3	2.45	.46	.67	.87				
	680	11.0	1.66	.46	.64	.81	10.0	1.95	.46	.66	.86	8.9	2.32	.48	.69	1.00	8.5	2.46	.48	.73	.96				

Entering Wet Bulb Temperature	Total Air Volume	Outdoor Air Temperature Entering Outdoor Coil														
		48°C					50°C					51.7°C				
		Total Cool Cap.	Comp. Motor Input	Sensible To Total Ratio (S/T)			Total Cool Cap.	Comp. Motor Input	Sensible To Total Ratio (S/T)			Total Cool Cap.	Comp. Motor Input	Sensible To Total Ratio (S/T)		
				Dry Bulb					Dry Bulb					Dry Bulb		
L/s	kW	kW	24°C	27°C	29°C	kW	kW	24°C	27°C	29°C	kW	kW	24°C	27°C	29°C	
17.2°C	455	6.9	2.54	.82	1.00	1.00	6.7	2.65	.84	1.00	1.00	6.7	2.81	.83	.97	.97
	565	7.3	2.55	.93	1.00	1.00	7.1	2.66	.95	1.00	1.00	7.1	2.81	.92	.97	.97
	680	7.7	2.55	1.00	1.00	1.00	7.4	2.67	1.00	1.00	1.00	7.5	2.82	.97	.97	.97
19.4°C	455	7.2	2.54	.62	.80	1.00	6.9	2.66	.62	.81	1.00	7.0	2.81	.62	.81	.97
	565	7.5	2.55	.67	.90	1.00	7.2	2.66	.68	.92	1.00	7.3	2.82	.68	.90	.97
	680	7.7	2.55	.72	.99	1.00	7.4	2.67	.73	1.00	1.00	7.5	2.82	.73	.97	.97
21.7°C	455	7.7	2.55	.43	.61	.78	7.4	2.66	.43	.62	.79	7.4	2.82	.43	.61	.79
	565	8.0	2.56	.45	.66	.87	7.6	2.67	.46	.68	.90	7.7	2.82	.46	.67	.88
	680	8.1	2.56	.48	.72	.97	7.8	2.67	.49	.73	.99	7.9	2.83	.48	.73	.95

## 14.0 KW - ZCB048S4

Entering Wet Bulb Temperature	Total Air Volume	Outdoor Air Temperature Entering Outdoor Coil																							
		26.7°C						35°C						43.3°C						46°C					
		Total Cool Cap.	Comp. Motor Input	Sensible To Total Ratio (S/T)			Total Cool Cap.	Comp. Motor Input	Sensible To Total Ratio (S/T)			Total Cool Cap.	Comp. Motor Input	Sensible To Total Ratio (S/T)			Total Cool Cap.	Comp. Motor Input	Sensible To Total Ratio (S/T)						
				Dry Bulb					Dry Bulb					Dry Bulb					Dry Bulb						
L/s	kW	kW	24°C	27°C	29°C	kW	kW	24°C	27°C	29°C	kW	kW	24°C	27°C	29°C	kW	kW	24°C	27°C	29°C					
17.2°C	604	11.7	2.29	0.75	0.90	1.00	11.1	2.74	0.78	0.95	1.00	10.6	3.30	0.82	1.00	1.00	10.5	3.51	.87	1.00	1.00				
	755	12.1	2.30	0.79	0.99	1.00	11.6	2.75	0.84	1.00	1.00	11.1	3.33	0.90	1.00	1.00	10.9	3.54	.94	1.00	1.00				
	906	12.5	2.32	0.86	1.00	1.00	12.0	2.77	0.92	1.00	1.00	11.4	3.35	0.98	1.00	1.00	11.3	3.57	1.00	1.00	1.00				
19.4°C	604	12.2	2.30	0.59	0.72	0.86	11.6	2.76	0.62	0.76	0.91	11.0	3.33	0.65	0.79	0.97	10.8	3.54	.69	.86	.97				
	755	12.6	2.32	0.62	0.78	0.96	12.0	2.77	0.65	0.81	1.00	11.3	3.34	0.69	0.87	1.00	11.1	3.56	.74	.94	1.00				
	906	12.9	2.33	0.66	0.84	1.00	12.2	2.79	0.69	0.89	1.00	11.5	3.36	0.73	0.96	1.00	11.3	3.57	.78	1.00	1.00				
21.7°C	604	12.7	2.32	0.45	0.57	0.70	12.1	2.78	0.47	0.60	0.73	11.4	3.35	0.50	0.64	0.77	11.2	3.57	.53	.69	.79				
	755	13.2	2.34	0.46	0.61	0.75	12.5	2.80	0.49	0.64	0.79	11.8	3.38	0.52	0.68	0.85	11.5	3.59	.55	.74	.87				
	906	13.5	2.36	0.47	0.65	0.81	12.8	2.81	0.50	0.69	0.87	12.0	3.39	0.53	0.72	0.93	11.7	3.60	.57	.79	.94				

Entering Wet Bulb Temperature	Total Air Volume	Outdoor Air Temperature Entering Outdoor Coil														
		48°C					50°C					51.7°C				
		Total Cool Cap.	Comp. Motor Input	Sensible To Total Ratio (S/T)			Total Cool Cap.	Comp. Motor Input	Sensible To Total Ratio (S/T)			Total Cool Cap.	Comp. Motor Input	Sensible To Total Ratio (S/T)		
				Dry Bulb					Dry Bulb					Dry Bulb		
L/s	kW	kW	24°C	27°C	29°C	kW	kW	24°C	27°C	29°C	kW	kW	24°C	27°C	29°C	
17.2°C	604	10.3	3.69	.84	1.00	1.00	10.2	3.87	.86	1.00	1.00	10.1	4.05	0.88	1.00	1.00
	755	10.7	3.72	.93	1.00	1.00	10.6	3.91	.95	1.00	1.00	10.4	4.08	0.97	1.00	1.00
	906	11.0	3.75	1.00	1.00	1.00	10.9	3.94	1.00	1.00	1.00	10.7	4.11	1.00	1.00	1.00
19.4°C	604	10.6	3.71	.67	.82	1.00	10.5	3.90	.69	.84	1.00	10.3	4.07	0.69	0.85	1.00
	755	10.9	3.73	.71	.91	1.00	10.7	3.92	.73	.93	1.00	10.6	4.09	0.74	0.95	1.00
	906	11.1	3.75	.76	.99	1.00	10.9	3.93	.77	1.00	1.00	10.7	4.11	0.78	1.00	1.00
21.7°C	604	11.0	3.75	.52	.66	.80	10.8	3.93	.53	.67	.81	10.7	4.10	0.54	0.68	0.83
	755	11.3	3.77	.53	.70	.89	11.1	3.96	.54	.72	.91	10.9	4.13	0.55	0.73	0.93
	906	11.5	3.78	.55	.75	.98	11.3	3.97	.56	.76	.99	11.0	4.14	0.57	0.77	1.00

# RATINGS

NOTE – For Temperatures and Capacities not shown in tables, see bulletin – Cooling Unit Rating Table Correction Factor Data in Miscellaneous Engineering Data section.

## 17.5 KW - ZCB060S4

Entering Wet Bulb Temperature	Total Air Volume	Outdoor Air Temperature Entering Outdoor Coil																			
		26.7°C					35°C					43.3°C					46°C				
		Total Cool Cap.	Comp. Motor Input	Sensible To Total Ratio (S/T)			Total Cool Cap.	Comp. Motor Input	Sensible To Total Ratio (S/T)			Total Cool Cap.	Comp. Motor Input	Sensible To Total Ratio (S/T)			Total Cool Cap.	Comp. Motor Input	Sensible To Total Ratio (S/T)		
				Dry Bulb					Dry Bulb					Dry Bulb					Dry Bulb		
L/s	kW	kW	24°C	27°C	29°C	kW	kW	24°C	27°C	29°C	kW	kW	24°C	27°C	29°C	kW	kW	24°C	27°C	29°C	
17.2°C	755	14.7	2.88	0.78	0.93	1.00	12.7	3.43	0.79	0.96	1.00	10.7	4.12	0.81	0.99	1.00	10.2	4.38	.80	1.00	1.00
	945	15.5	2.89	0.86	0.99	1.00	13.7	3.44	0.87	1.00	1.00	11.8	4.16	0.9	1.00	1.00	11.2	4.43	.91	1.00	1.00
	1135	16.5	2.91	0.91	1.00	1.00	14.7	3.47	0.94	1.00	1.00	12.6	4.19	0.97	1.00	1.00	12.0	4.46	.99	1.00	1.00
19.4°C	755	15.9	2.9	0.6	0.76	0.91	13.9	3.45	0.59	0.77	0.93	11.7	4.16	0.57	0.79	0.97	11.0	4.41	.56	.80	.95
	945	16.7	2.91	0.64	0.83	0.97	14.6	3.46	0.64	0.86	1.00	12.4	4.18	0.64	0.89	1.00	11.6	4.44	.63	.90	1.00
	1135	17.4	2.92	0.69	0.89	1.00	15.1	3.47	0.69	0.92	1.00	12.9	4.20	0.71	0.96	1.00	12.1	4.46	.70	.99	1.00
21.7°C	755	17.0	2.91	0.43	0.59	0.74	15.0	3.48	0.41	0.58	0.75	12.7	4.19	0.36	0.57	0.77	12.0	4.46	.36	.58	.72
	945	17.9	2.93	0.45	0.64	0.81	15.8	3.49	0.43	0.63	0.83	13.5	4.22	0.4	0.65	0.87	12.7	4.49	.39	.66	.82
	1135	18.6	2.95	0.48	0.69	0.88	16.3	3.51	0.46	0.69	0.90	13.9	4.25	0.44	0.71	0.94	13.1	4.52	.43	.72	.91

Entering Wet Bulb Temperature	Total Air Volume	Outdoor Air Temperature Entering Outdoor Coil														
		48°C					50°C					51.7°C				
		Total Cool Cap.	Comp. Motor Input	Sensible To Total Ratio (S/T)			Total Cool Cap.	Comp. Motor Input	Sensible To Total Ratio (S/T)			Total Cool Cap.	Comp. Motor Input	Sensible To Total Ratio (S/T)		
				Dry Bulb					Dry Bulb					Dry Bulb		
L/s	kW	kW	24°C	27°C	29°C	kW	kW	24°C	27°C	29°C	kW	kW	24°C	27°C	29°C	
17.2°C	755	9.6	4.59	.83	1.00	1.00	9.1	4.82	.85	1.00	1.00	8.7	5.03	0.86	1.00	1.00
	945	10.6	4.64	.93	1.00	1.00	10.1	4.88	.94	1.00	1.00	9.6	5.09	0.96	1.00	1.00
	1135	11.3	4.68	1.00	1.00	1.00	10.8	4.91	1.00	1.00	1.00	10.3	5.13	1.00	1.00	1.00
19.4°C	755	10.4	4.63	.57	.81	.99	9.8	4.86	.57	.82	1.00	9.3	5.07	0.56	0.84	1.00
	945	11.0	4.66	.64	.92	1.00	10.4	4.89	.65	.93	1.00	9.8	5.10	0.65	0.94	1.00
	1135	11.4	4.69	.72	.99	1.00	10.8	4.92	.73	1.00	1.00	10.3	5.13	0.73	1.00	1.00
21.7°C	755	11.4	4.68	.33	.57	.79	10.8	4.91	.32	.57	.80	10.2	5.12	0.32	0.57	0.81
	945	12.0	4.71	.38	.65	.90	11.3	4.94	.37	.65	.91	10.8	5.16	0.36	0.66	0.92
	1135	12.4	4.74	.42	.73	.97	11.8	4.98	.41	.73	.98	11.2	5.19	0.41	0.75	1.00

# RATINGS

NOTE – For Temperatures and Capacities not shown in tables, see bulletin – Cooling Unit Rating Table Correction Factor Data in Miscellaneous Engineering Data section.

## 21 KW - ZCB074S4T - COOLING CAPACITY (1ST STAGE)

Entering Wet Bulb Temperature	Total Air Volume	Outdoor Air Temperature Entering Outdoor Coil																							
		18.1°C						24°C						29°C						35°C					
		Total Cool Cap.	Comp. Motor Input	Sensible To Total Ratio (S/T)			Total Cool Cap.	Comp. Motor Input	Sensible To Total Ratio (S/T)			Total Cool Cap.	Comp. Motor Input	Sensible To Total Ratio (S/T)			Total Cool Cap.	Comp. Motor Input	Sensible To Total Ratio (S/T)						
				Dry Bulb					Dry Bulb					Dry Bulb					Dry Bulb						
L/s	kW	kW	24°C	27°C	29°C	kW	kW	24°C	27°C	29°C	kW	kW	24°C	27°C	29°C	kW	kW	24°C	27°C	29°C					
17.2°C	565	13.0	1.85	0.74	0.88	0.98	12.1	2.13	0.74	0.90	1.00	11.3	2.39	0.75	0.92	1.00	10.3	2.76	0.76	0.95	1.00				
	755	14.1	1.84	0.81	0.99	1.00	13.2	2.12	0.82	1.00	1.00	12.4	2.39	0.83	1.00	1.00	11.5	2.76	0.86	1.00	1.00				
	945	15.2	1.83	0.88	1.00	1.00	14.3	2.11	0.90	1.00	1.00	13.5	2.39	0.93	1.00	1.00	12.5	2.75	0.95	1.00	1.00				
19.4°C	565	13.9	1.84	0.59	0.73	0.83	13.0	2.12	0.59	0.74	0.84	12.2	2.39	0.59	0.75	0.86	11.1	2.76	0.59	0.76	0.88				
	755	15.1	1.83	0.65	0.82	0.93	14.0	2.12	0.65	0.83	0.95	13.1	2.39	0.65	0.84	0.97	12.0	2.76	0.66	0.87	1.00				
	945	15.8	1.83	0.70	0.89	1.00	14.7	2.11	0.70	0.91	1.00	13.8	2.38	0.71	0.93	1.00	12.6	2.75	0.72	0.97	1.00				
21.7°C	565	15.2	1.83	0.41	0.54	0.63	14.3	2.12	0.40	0.54	0.63	13.5	2.39	0.39	0.54	0.63	12.3	2.75	0.37	0.53	0.64				
	755	16.5	1.82	0.42	0.59	0.69	15.4	2.11	0.42	0.59	0.70	14.5	2.38	0.41	0.59	0.71	13.3	2.75	0.39	0.59	0.72				
	945	17.3	1.81	0.45	0.63	0.74	16.2	2.10	0.44	0.64	0.76	15.2	2.37	0.43	0.64	0.78	13.9	2.74	0.42	0.65	0.80				

## 21 KW - ZCB074S4T - COOLING CAPACITY (2ND STAGE)

Entering Wet Bulb Temperature	Total Air Volume	Outdoor Air Temperature Entering Outdoor Coil																							
		26.7°C						35°C						43.3°C						46°C					
		Total Cool Cap.	Comp. Motor Input	Sensible To Total Ratio (S/T)			Total Cool Cap.	Comp. Motor Input	Sensible To Total Ratio (S/T)			Total Cool Cap.	Comp. Motor Input	Sensible To Total Ratio (S/T)			Total Cool Cap.	Comp. Motor Input	Sensible To Total Ratio (S/T)						
				Dry Bulb					Dry Bulb					Dry Bulb					Dry Bulb						
L/s	kW	kW	24°C	27°C	29°C	kW	kW	24°C	27°C	29°C	kW	kW	24°C	27°C	29°C	kW	kW	24°C	27°C	29°C					
17.2°C	905	16.9	3.26	0.79	0.97	1.00	15.1	3.90	0.82	1.00	1.00	13.5	4.69	0.85	1.00	1.00	12.9	4.98	0.86	1.00	1.00				
	1135	18.0	3.29	0.86	1.00	1.00	16.3	3.95	0.90	1.00	1.00	14.5	4.74	0.95	1.00	1.00	13.9	5.03	0.97	1.00	1.00				
	1360	18.9	3.33	0.94	1.00	1.00	17.2	3.98	0.97	1.00	1.00	15.3	4.77	1.00	1.00	1.00	14.7	5.06	1.00	1.00	1.00				
19.4°C	905	17.9	3.29	0.63	0.80	0.91	16.1	3.94	0.63	0.83	0.95	14.1	4.72	0.65	0.86	1.00	13.4	5.00	0.65	0.88	1.00				
	1135	18.7	3.32	0.68	0.88	1.00	16.8	3.97	0.69	0.91	1.00	14.7	4.75	0.71	0.96	1.00	14.0	5.03	0.72	0.98	1.00				
	1360	19.3	3.34	0.73	0.95	1.00	17.3	3.99	0.74	0.99	1.00	15.3	4.77	0.77	1.00	1.00	14.7	5.06	0.79	1.00	1.00				
21.7°C	905	19.4	3.35	0.41	0.57	0.67	17.5	4.00	0.40	0.58	0.69	15.5	4.78	0.38	0.58	0.71	14.8	5.07	0.38	0.59	0.72				
	1135	20.3	3.38	0.43	0.62	0.74	18.3	4.03	0.42	0.63	0.76	16.1	4.81	0.41	0.64	0.80	15.4	5.10	0.40	0.65	0.81				
	1360	21.0	3.41	0.44	0.66	0.80	18.9	4.06	0.44	0.68	0.83	16.6	4.84	0.43	0.70	0.88	15.9	5.13	0.43	0.71	0.89				

Entering Wet Bulb Temperature	Total Air Volume	Outdoor Air Temperature Entering Outdoor Coil																	
		48°C						50°C						51.7°C					
		Total Cool Cap.	Comp. Motor Input	Sensible To Total Ratio (S/T)			Total Cool Cap.	Comp. Motor Input	Sensible To Total Ratio (S/T)			Total Cool Cap.	Comp. Motor Input	Sensible To Total Ratio (S/T)					
				Dry Bulb					Dry Bulb					Dry Bulb					
L/s	kW	kW	24°C	27°C	29°C	kW	kW	24°C	27°C	29°C	kW	kW	24°C	27°C	29°C				
17.2°C	905	12.5	5.21	0.88	1.00	1.00	12.0	5.46	0.89	1.00	1.00	11.6	5.68	0.91	1.00	1.00			
	1135	13.4	5.25	0.98	1.00	1.00	12.9	5.50	1.00	1.00	1.00	12.5	5.72	1.00	1.00	1.00			
	1360	14.2	5.29	1.00	1.00	1.00	13.6	5.54	1.00	1.00	1.00	13.2	5.75	1.00	1.00	1.00			
19.4°C	905	12.9	5.23	0.66	0.89	1.00	12.3	5.47	0.66	0.91	1.00	11.8	5.69	0.67	0.93	1.00			
	1135	13.5	5.26	0.73	1.00	1.00	13.0	5.50	0.74	1.00	1.00	12.5	5.72	0.75	1.00	1.00			
	1360	14.2	5.29	0.80	1.00	1.00	13.6	5.53	0.81	1.00	1.00	13.2	5.75	0.83	1.00	1.00			
21.7°C	905	14.2	5.29	0.37	0.59	0.73	13.7	5.54	0.37	0.60	0.74	13.2	5.75	0.37	0.60	0.75			
	1135	14.9	5.32	0.40	0.66	0.82	14.2	5.57	0.40	0.67	0.84	13.7	5.78	0.40	0.67	0.85			
	1360	15.3	5.35	0.43	0.72	0.91	14.7	5.59	0.43	0.73	0.93	14.1	5.81	0.43	0.74	0.94			

# RATINGS

NOTE – For Temperatures and Capacities not shown in tables, see bulletin – Cooling Unit Rating Table Correction Factor Data in Miscellaneous Engineering Data section.

## 21 KW - ZCB074S4B - COOLING CAPACITY (1ST STAGE)

Entering Wet Bulb Temperature	Total Air Volume	Outdoor Air Temperature Entering Outdoor Coil																							
		18.1°C						24°C						29°C						35°C					
		Total Cool Cap.	Comp. Motor Input	Sensible To Total Ratio (S/T)			Total Cool Cap.	Comp. Motor Input	Sensible To Total Ratio (S/T)			Total Cool Cap.	Comp. Motor Input	Sensible To Total Ratio (S/T)			Total Cool Cap.	Comp. Motor Input	Sensible To Total Ratio (S/T)						
				Dry Bulb					Dry Bulb					Dry Bulb					Dry Bulb						
L/s	kW	kW	24°C	27°C	29°C	kW	kW	24°C	27°C	29°C	kW	kW	24°C	27°C	29°C	kW	kW	24°C	27°C	29°C					
17.2°C	905	15.9	18.6	.86	1.00	1.00	14.9	21.5	.88	1.00	1.00	14.1	24.3	.90	1.00	1.00	13.1	28.0	.93	1.00	1.00				
	1135	17.1	18.5	.95	1.00	1.00	16.1	21.4	.97	1.00	1.00	15.2	24.2	.99	1.00	1.00	14.1	28.0	1.00	1.00	1.00				
	1360	18.0	18.4	1.00	1.00	1.00	16.9	21.3	1.00	1.00	1.00	16.1	24.1	1.00	1.00	1.00	14.9	27.9	1.00	1.00	1.00				
19.4°C	905	16.6	18.5	.68	.87	.99	15.6	21.5	.68	.89	1.00	14.6	24.2	.69	.91	1.00	13.4	28.0	.70	.94	1.00				
	1135	17.3	18.5	.73	.96	1.00	16.2	21.4	.75	.98	1.00	15.3	24.2	.76	1.00	1.00	14.1	28.0	.77	1.00	1.00				
	1360	18.0	18.4	.79	1.00	1.00	17.0	21.4	.80	1.00	1.00	16.0	24.1	.82	1.00	1.00	14.9	27.9	.84	1.00	1.00				
21.7°C	905	18.2	18.4	.44	.62	.73	17.1	21.3	.43	.62	.74	16.1	24.1	.42	.63	.76	14.9	27.9	.42	.64	.77				
	1135	19.0	18.3	.46	.67	.80	17.8	21.3	.45	.67	.82	16.8	24.0	.45	.68	.84	15.5	27.9	.44	.70	.86				
	1360	19.6	18.2	.48	.72	.87	18.3	21.2	.47	.73	.89	17.3	24.0	.47	.74	.91	15.9	27.9	.47	.76	.95				

## 21 KW - ZCB074S4B - COOLING CAPACITY (2ND STAGE)

Entering Wet Bulb Temperature	Total Air Volume	Outdoor Air Temperature Entering Outdoor Coil																							
		26.7°C						35°C						43.3°C						46°C					
		Total Cool Cap.	Comp. Motor Input	Sensible To Total Ratio (S/T)			Total Cool Cap.	Comp. Motor Input	Sensible To Total Ratio (S/T)			Total Cool Cap.	Comp. Motor Input	Sensible To Total Ratio (S/T)			Total Cool Cap.	Comp. Motor Input	Sensible To Total Ratio (S/T)						
				Dry Bulb					Dry Bulb					Dry Bulb					Dry Bulb						
L/s	kW	kW	24°C	27°C	29°C	kW	kW	24°C	27°C	29°C	kW	kW	24°C	27°C	29°C	kW	kW	24°C	27°C	29°C					
17.2°C	905	17.6	32.7	.79	.97	1.00	15.8	39.2	.82	1.00	1.00	14.1	47.1	.85	1.00	1.00	13.5	50.0	.86	1.00	1.00				
	1135	18.8	33.0	.86	1.00	1.00	17.1	39.6	.90	1.00	1.00	15.2	47.5	.95	1.00	1.00	14.6	50.4	.97	1.00	1.00				
	1360	19.8	33.4	.94	1.00	1.00	18.0	40.0	.97	1.00	1.00	16.1	47.9	1.00	1.00	1.00	15.4	50.8	1.00	1.00	1.00				
19.4°C	905	18.7	33.0	.63	.80	.91	16.8	39.5	.63	.83	.95	14.8	47.4	.65	.87	1.00	14.1	50.2	.65	.88	1.00				
	1135	19.5	33.3	.68	.88	1.00	17.6	39.8	.69	.91	1.00	15.4	47.6	.71	.96	1.00	14.7	50.5	.72	.98	1.00				
	1360	20.1	33.6	.73	.95	1.00	18.1	40.0	.74	.99	1.00	16.1	47.9	.77	1.00	1.00	15.4	50.8	.79	1.00	1.00				
21.7°C	905	20.3	33.6	.41	.57	.67	18.3	40.1	.40	.58	.69	16.3	48.0	.38	.59	.71	15.5	50.8	.38	.59	.73				
	1135	21.2	33.9	.43	.62	.74	19.1	40.5	.42	.63	.76	16.9	48.3	.41	.65	.80	16.1	51.2	.41	.65	.81				
	1360	21.9	34.2	.44	.66	.80	19.7	40.7	.44	.68	.83	17.4	48.6	.43	.70	.88	16.7	51.4	.43	.71	.89				

Entering Wet Bulb Temperature	Total Air Volume	Outdoor Air Temperature Entering Outdoor Coil																	
		48°C						50°C						51.7°C					
		Total Cool Cap.	Comp. Motor Input	Sensible To Total Ratio (S/T)			Total Cool Cap.	Comp. Motor Input	Sensible To Total Ratio (S/T)			Total Cool Cap.	Comp. Motor Input	Sensible To Total Ratio (S/T)					
				Dry Bulb					Dry Bulb					Dry Bulb					
L/s	kW	kW	24°C	27°C	29°C	kW	kW	24°C	27°C	29°C	kW	kW	24°C	27°C	29°C				
17.2°C	905	13.1	52.3	.88	1.00	1.00	12.6	54.8	.89	1.00	1.00	12.2	57.0	.91	1.00	1.00			
	1135	14.1	52.7	.98	1.00	1.00	13.6	55.2	1.00	1.00	1.00	13.1	57.4	1.00	1.00	1.00			
	1360	14.9	53.1	1.00	1.00	1.00	14.3	55.5	1.00	1.00	1.00	13.9	57.7	1.00	1.00	1.00			
19.4°C	905	13.6	52.5	.66	.89	1.00	12.9	54.9	.66	.91	1.00	12.4	57.1	.67	.93	1.00			
	1135	14.1	52.8	.73	1.00	1.00	13.6	55.2	.74	1.00	1.00	13.2	57.5	.75	1.00	1.00			
	1360	14.9	53.1	.80	1.00	1.00	14.3	55.5	.81	1.00	1.00	13.9	57.7	.83	1.00	1.00			
21.7°C	905	14.9	53.1	.38	.59	.73	14.4	55.6	.37	.60	.74	13.9	57.7	.37	.60	.75			
	1135	15.6	53.4	.40	.66	.82	14.9	55.9	.40	.67	.84	14.4	58.0	.40	.67	.85			
	1360	16.1	53.7	.43	.72	.91	15.4	56.1	.43	.73	.93	14.8	58.3	.43	.74	.94			



**BLOWER DATA**

**BELT DRIVE | 3 TON**

**BLOWER TABLE INCLUDES RESISTANCE FOR BASE UNIT ONLY WITH DRY INDOOR COIL AND AIR FILTERS IN PLACE. FOR ALL UNITS ADD:**

- 1 - Any factory installed options air resistance (heat section, economizer, wet coil, etc.).
- 2 - Any field installed accessories air resistance (duct resistance, diffuser, etc.).

See page 25 for blower motors and drives and wet coil and options/accessory air resistance data.

**DOWNFLOW**

Air Volume		External Static - Pa (in. w.g.)																							
		25 (0.10)		50 (0.20)		75 (0.30)		100 (0.40)		125 (0.50)		150 (0.60)		175 (0.70)		200 (0.80)									
L/s	cfm	Rev/min	kW	BHP	Rev/min	kW	BHP	Rev/min	kW	BHP	Rev/min	kW	BHP	Rev/min	kW	BHP	Rev/min	kW	BHP						
425	900	562	0.12	0.16	629	0.13	0.18	699	0.14	0.19	771	0.15	0.2	840	0.16	0.22	904	0.18	0.24	962	0.19	0.26	1015	0.22	0.29
472	1000	586	0.13	0.18	654	0.15	0.2	725	0.16	0.21	796	0.17	0.23	864	0.19	0.25	927	0.20	0.27	983	0.22	0.3	1034	0.25	0.33
519	1100	612	0.15	0.2	681	0.16	0.22	752	0.18	0.24	823	0.19	0.26	890	0.21	0.28	950	0.23	0.31	1004	0.25	0.34	1054	0.28	0.37
566	1200	641	0.17	0.23	711	0.19	0.25	783	0.20	0.27	852	0.22	0.29	917	0.24	0.32	975	0.26	0.35	1027	0.29	0.39	1074	0.31	0.42
613	1300	673	0.19	0.25	744	0.21	0.28	815	0.22	0.3	882	0.25	0.33	944	0.27	0.36	1000	0.30	0.4	1050	0.33	0.44	1096	0.36	0.48
661	1400	709	0.22	0.29	779	0.24	0.32	849	0.25	0.34	914	0.28	0.37	973	0.31	0.41	1026	0.34	0.45	1074	0.37	0.49	1118	0.40	0.53
708	1500	747	0.25	0.33	816	0.27	0.36	883	0.29	0.39	945	0.31	0.42	1001	0.34	0.46	1052	0.38	0.51	1098	0.41	0.55	1141	0.44	0.59

**External Static - Pa (in. w.g.)**

Air Volume		External Static - Pa (in. w.g.)																							
		225 (0.90)		250 (1.00)		275 (1.10)		300 (1.20)		325 (1.30)		350 (1.40)		375 (1.50)		400 (1.60)									
L/s	cfm	Rev/min	kW	BHP	Rev/min	kW	BHP	Rev/min	kW	BHP	Rev/min	kW	BHP	Rev/min	kW	BHP	Rev/min	kW	BHP						
425	900	1065	0.24	0.32	1112	0.26	0.35	1158	0.28	0.38	1202	0.31	0.41	1243	0.33	0.44	1284	0.36	0.48	1323	0.39	0.52	1364	0.41	0.55
472	1000	1082	0.27	0.36	1128	0.29	0.39	1173	0.31	0.42	1216	0.34	0.45	1257	0.37	0.49	1297	0.40	0.53	1336	0.43	0.57	1375	0.45	0.60
519	1100	1100	0.30	0.4	1145	0.33	0.44	1189	0.35	0.47	1231	0.38	0.51	1272	0.40	0.54	1311	0.43	0.58	1349	0.46	0.62	1388	0.49	0.66
566	1200	1119	0.34	0.45	1163	0.37	0.49	1206	0.39	0.52	1247	0.42	0.56	1287	0.45	0.60	1326	0.48	0.64	1364	0.51	0.68	1402	0.54	0.72
613	1300	1139	0.38	0.51	1182	0.41	0.55	1224	0.43	0.58	1265	0.46	0.62	1304	0.49	0.66	1342	0.53	0.71	1379	0.56	0.75	1416	0.59	0.79
661	1400	1160	0.43	0.57	1202	0.46	0.61	1243	0.48	0.65	1283	0.51	0.69	1322	0.54	0.73	1359	0.58	0.78	1396	0.61	0.82	1432	0.65	0.87
708	1500	1182	0.48	0.64	1223	0.51	0.68	1263	0.54	0.72	1303	0.57	0.76	1341	0.60	0.81	1378	0.63	0.85	1414	0.67	0.9	1449	0.70	0.94

**BLOWER TABLE INCLUDES RESISTANCE FOR BASE UNIT ONLY WITH DRY INDOOR COIL AND AIR FILTERS IN PLACE. FOR ALL UNITS ADD:**

- 1 - Any factory installed options air resistance (heat section, economizer, wet coil, etc.).
  - 2 - Any field installed accessories air resistance (duct resistance, diffuser, etc.).
- See page 25 for blower motors and drives and wet coil and options/accessory air resistance data.

**HORIZONTAL**

Air Volume		External Static - Pa (in. w.g.)																							
		25 (0.10)			50 (0.20)			75 (0.30)			100 (0.40)			125 (0.50)			150 (0.60)			175 (0.70)			200 (0.80)		
L/s	cfm	Rev/min	kw	BHP	Rev/min	kw	BHP	Rev/min	kw	BHP	Rev/min	kw	BHP	Rev/min	kw	BHP	Rev/min	kw	BHP	Rev/min	kw	BHP	Rev/min	kw	BHP
425	900	580	0.10	0.14	649	0.13	0.17	721	0.14	0.19	794	0.16	0.22	868	0.18	0.24	938	0.20	0.27	998	0.22	0.3	1045	0.25	0.33
472	1000	612	0.13	0.17	681	0.14	0.19	752	0.16	0.22	825	0.19	0.25	897	0.20	0.27	963	0.22	0.3	1017	0.25	0.33	1061	0.28	0.37
519	1100	647	0.15	0.2	717	0.17	0.23	788	0.19	0.26	858	0.21	0.28	926	0.23	0.31	986	0.25	0.34	1036	0.28	0.38	1077	0.31	0.41
566	1200	687	0.17	0.23	757	0.19	0.26	826	0.22	0.29	893	0.24	0.32	955	0.26	0.35	1008	0.29	0.39	1054	0.31	0.42	1095	0.34	0.46
613	1300	730	0.20	0.27	798	0.22	0.3	864	0.25	0.33	926	0.28	0.37	982	0.30	0.4	1030	0.33	0.44	1073	0.35	0.47	1116	0.38	0.51
661	1400	775	0.23	0.31	840	0.25	0.34	902	0.28	0.38	959	0.31	0.42	1009	0.34	0.46	1054	0.37	0.5	1096	0.40	0.53	1140	0.42	0.56
708	1500	820	0.27	0.36	881	0.30	0.4	939	0.33	0.44	993	0.37	0.49	1039	0.40	0.53	1082	0.42	0.56	1124	0.44	0.59	1168	0.46	0.62

Air Volume		External Static - Pa (in. w.g.)																							
		225 (0.90)			250 (1.00)			275 (1.10)			300 (1.20)			325 (1.30)			350 (1.40)			375 (1.50)			400 (1.60)		
L/s	cfm	Rev/min	kw	BHP	Rev/min	kw	BHP	Rev/min	kw	BHP	Rev/min	kw	BHP	Rev/min	kw	BHP	Rev/min	kw	BHP	Rev/min	kw	BHP	Rev/min	kw	BHP
425	900	1091	0.27	0.36	1140	0.28	0.38	1188	0.30	0.4	1232	0.32	0.43	1272	0.34	0.46	1309	0.37	0.49	1346	0.40	0.53	1383	0.43	0.57
472	1000	1105	0.30	0.4	1154	0.31	0.42	1201	0.34	0.45	1245	0.35	0.47	1284	0.37	0.5	1321	0.40	0.54	1357	0.43	0.58	1394	0.46	0.62
519	1100	1121	0.33	0.44	1169	0.35	0.47	1216	0.37	0.49	1259	0.39	0.52	1298	0.42	0.56	1335	0.45	0.6	1370	0.48	0.64	1406	0.51	0.69
566	1200	1139	0.37	0.49	1187	0.39	0.52	1234	0.40	0.54	1276	0.43	0.58	1314	0.46	0.62	1350	0.49	0.66	1385	0.53	0.71	1421	0.56	0.75
613	1300	1161	0.40	0.54	1208	0.43	0.57	1254	0.45	0.6	1295	0.48	0.64	1332	0.51	0.69	1366	0.54	0.73	1401	0.58	0.78	1436	0.62	0.83
661	1400	1185	0.44	0.59	1232	0.47	0.63	1276	0.50	0.67	1315	0.53	0.71	1351	0.57	0.76	1384	0.60	0.81	1419	0.64	0.86	1454	0.67	0.9
708	1500	1212	0.49	0.66	1257	0.52	0.7	1299	0.55	0.74	1337	0.59	0.79	1371	0.63	0.84	1404	0.66	0.89	1438	0.70	0.94	1473	0.74	0.99

**BLOWER DATA**

**BELT DRIVE | 4 TON**

**BLOWER TABLE INCLUDES RESISTANCE FOR BASE UNIT ONLY WITH DRY INDOOR COIL AND AIR FILTERS IN PLACE. FOR ALL UNITS ADD:**

- 1 - Any factory installed options air resistance (heat section, economizer, wet coil, etc.).
  - 2 - Any field installed accessories air resistance (duct resistance, diffuser, etc.).
- See page 25 for blower motors and drives and wet coil and options/accessory air resistance data.

**DOWNFLOW**

Air Volume		External Static - Pa (in. w.g.)																							
		25 (0.10)		50 (0.20)		75 (0.30)		100 (0.40)		125 (0.50)		150 (0.60)		175 (0.70)		200 (0.80)									
L/s	cfm	Rev/min	kW	BHP	Rev/min	kW	BHP	Rev/min	kW	BHP	Rev/min	kW	BHP	Rev/min	kW	BHP	Rev/min	kW	BHP						
565	1200	641	0.17	0.23	711	0.19	0.25	783	0.20	0.27	852	0.22	0.29	917	0.24	0.32	975	0.26	0.35	1027	0.29	0.39	1074	0.31	0.42
615	1300	673	0.19	0.25	744	0.21	0.28	815	0.22	0.3	882	0.25	0.33	944	0.27	0.36	1000	0.30	0.4	1050	0.33	0.44	1096	0.36	0.48
660	1400	709	0.22	0.29	779	0.24	0.32	849	0.25	0.34	914	0.28	0.37	973	0.31	0.41	1026	0.34	0.45	1074	0.37	0.49	1118	0.40	0.53
710	1500	747	0.25	0.33	816	0.27	0.36	883	0.29	0.39	945	0.31	0.42	1001	0.34	0.46	1052	0.38	0.51	1098	0.41	0.55	1141	0.44	0.59
755	1600	787	0.28	0.38	854	0.31	0.41	918	0.33	0.44	976	0.36	0.48	1030	0.39	0.52	1078	0.42	0.56	1123	0.46	0.61	1164	0.49	0.66
800	1700	827	0.32	0.43	892	0.34	0.46	952	0.37	0.49	1007	0.40	0.53	1058	0.43	0.58	1105	0.47	0.63	1148	0.51	0.68	1189	0.54	0.73
850	1800	868	0.36	0.48	929	0.39	0.52	986	0.41	0.55	1038	0.44	0.59	1087	0.48	0.64	1132	0.51	0.69	1174	0.56	0.75	1214	0.60	0.8
895	1900	907	0.40	0.54	966	0.43	0.58	1019	0.46	0.62	1069	0.49	0.66	1116	0.53	0.71	1160	0.57	0.77	1200	0.61	0.82	1240	0.66	0.88
945	2000	946	0.45	0.6	1001	0.48	0.65	1053	0.51	0.69	1101	0.55	0.74	1146	0.59	0.79	1188	0.63	0.85	1228	0.68	0.91	1267	0.73	0.98
Air Volume		External Static - Pa (in. w.g.)																							
		225 (0.90)		250 (1.00)		275 (1.10)		300 (1.20)		325 (1.30)		350 (1.40)		375 (1.50)		400 (1.60)									
L/s	cfm	Rev/min	kW	BHP	Rev/min	kW	BHP	Rev/min	kW	BHP	Rev/min	kW	BHP	Rev/min	kW	BHP	Rev/min	kW	BHP						
565	1200	1119	0.34	0.45	1163	0.37	0.49	1206	0.39	0.52	1247	0.42	0.56	1287	0.45	0.6	1326	0.48	0.64	1364	0.51	0.68	1402	0.54	0.72
615	1300	1139	0.38	0.51	1182	0.41	0.55	1224	0.43	0.58	1265	0.46	0.62	1304	0.49	0.66	1342	0.53	0.71	1379	0.56	0.75	1416	0.59	0.79
660	1400	1160	0.43	0.57	1202	0.46	0.61	1243	0.48	0.65	1283	0.51	0.69	1322	0.54	0.73	1359	0.58	0.78	1396	0.61	0.82	1432	0.65	0.87
710	1500	1182	0.48	0.64	1223	0.51	0.68	1263	0.54	0.72	1303	0.57	0.76	1341	0.60	0.81	1378	0.63	0.85	1414	0.67	0.9	1449	0.70	0.94
755	1600	1205	0.52	0.7	1245	0.56	0.75	1284	0.59	0.79	1323	0.63	0.84	1361	0.66	0.88	1397	0.69	0.93	1432	0.73	0.98	1467	0.77	1.03
800	1700	1228	0.58	0.78	1268	0.61	0.82	1307	0.65	0.87	1345	0.69	0.92	1382	0.72	0.97	1417	0.76	1.02	1452	0.80	1.07	1486	0.83	1.11
850	1800	1253	0.63	0.85	1292	0.68	0.91	1331	0.72	0.96	1368	0.75	1.01	1404	0.79	1.06	1439	0.83	1.11	1473	0.87	1.16	1506	0.90	1.21
895	1900	1279	0.70	0.94	1317	0.75	1.00	1355	0.78	1.05	1392	0.82	1.1	1427	0.87	1.16	1461	0.90	1.21	1494	0.94	1.26	1527	0.98	1.31
945	2000	1305	0.78	1.04	1343	0.82	1.10	1380	0.86	1.15	1416	0.90	1.21	1450	0.94	1.26	1484	0.98	1.32	1516	1.02	1.37	1549	1.06	1.42

**BLOWER DATA**

**BELT DRIVE I 4 TON**

**BLOWER TABLE INCLUDES RESISTANCE FOR BASE UNIT ONLY WITH DRY INDOOR COIL AND AIR FILTERS IN PLACE. FOR ALL UNITS ADD:**

1 - Any factory installed options air resistance (heat section, economizer, wet coil, etc.).

2 - Any field installed accessories air resistance (duct resistance, diffuser, etc.).

See page 25 for blower motors and drives and wet coil and options/accessory air resistance data.

**HORIZONTAL**

Air Volume		External Static - Pa (in. w.g.)																					
		25 (0.10)		50 (0.20)		75 (0.30)		100 (0.40)		125 (0.50)		150 (0.60)		175 (0.70)		200 (0.80)							
L/s	cfm	Rev/ min	kW	BHP	Rev/ min	kW	BHP	Rev/ min	kW	BHP	Rev/ min	kW	BHP	Rev/ min	kW	BHP	Rev/ min	kW	BHP				
565	1200	687	0.17	0.23	757	0.19	0.26	0.29	893	0.24	0.32	0.26	0.35	1008	0.29	0.39	1054	0.31	0.42	1095	0.34	0.46	
615	1300	730	0.20	0.27	798	0.22	0.30	0.33	926	0.28	0.37	982	0.30	0.40	1030	0.33	0.44	1073	0.35	0.47	1116	0.38	0.51
660	1400	775	0.23	0.31	840	0.25	0.34	0.38	959	0.31	0.42	1009	0.34	0.46	1054	0.37	0.50	1096	0.40	0.53	1140	0.42	0.56
710	1500	820	0.27	0.36	881	0.30	0.40	0.44	993	0.37	0.49	1039	0.40	0.53	1082	0.42	0.56	1124	0.44	0.59	1168	0.46	0.62
755	1600	864	0.31	0.42	921	0.34	0.46	0.51	1027	0.42	0.56	1072	0.45	0.60	1113	0.47	0.63	1155	0.49	0.66	1198	0.51	0.69
800	1700	907	0.36	0.48	961	0.40	0.53	0.58	1061	0.47	0.63	1105	0.50	0.67	1146	0.52	0.70	1187	0.54	0.73	1230	0.57	0.77
850	1800	948	0.42	0.56	999	0.46	0.61	0.66	1096	0.53	0.71	1139	0.56	0.75	1180	0.58	0.78	1221	0.61	0.82	1262	0.64	0.86
895	1900	987	0.48	0.64	1037	0.51	0.69	0.74	1132	0.59	0.79	1174	0.62	0.83	1214	0.64	0.86	1255	0.67	0.90	1295	0.71	0.95
945	2000	1028	0.54	0.73	1076	0.58	0.78	0.83	1168	0.65	0.87	1210	0.68	0.91	1250	0.72	0.96	1289	0.75	1.00	1328	0.79	1.06

**External Static - Pa (in. w.g.)**

Air Volume		External Static - Pa (in. w.g.)																							
		225 (0.90)		250 (1.00)		275 (1.10)		300 (1.20)		325 (1.30)		350 (1.40)		375 (1.50)		400 (1.60)									
L/s	cfm	Rev/ min	kW	BHP	Rev/ min	kW	BHP	Rev/ min	kW	BHP	Rev/ min	kW	BHP	Rev/ min	kW	BHP	Rev/ min	kW	BHP						
565	1200	1139	0.37	0.49	1187	0.39	0.52	1234	0.40	0.54	1276	0.43	0.58	1314	0.46	0.62	1350	0.49	0.66	1385	0.53	0.71	1421	0.56	0.75
615	1300	1161	0.40	0.54	1208	0.43	0.57	1254	0.45	0.60	1295	0.48	0.64	1332	0.51	0.69	1366	0.54	0.73	1401	0.58	0.78	1436	0.62	0.83
660	1400	1185	0.44	0.59	1232	0.47	0.63	1276	0.50	0.67	1315	0.53	0.71	1351	0.57	0.76	1384	0.60	0.81	1419	0.64	0.86	1454	0.67	0.90
710	1500	1212	0.49	0.66	1257	0.52	0.70	1299	0.55	0.74	1337	0.59	0.79	1371	0.63	0.84	1404	0.66	0.89	1438	0.70	0.94	1473	0.74	0.99
755	1600	1242	0.54	0.73	1284	0.57	0.77	1324	0.61	0.82	1360	0.66	0.88	1394	0.69	0.93	1426	0.74	0.99	1460	0.78	1.04	1495	0.81	1.08
800	1700	1272	0.60	0.81	1312	0.64	0.86	1350	0.69	0.92	1385	0.73	0.98	1418	0.78	1.04	1451	0.81	1.09	1485	0.85	1.14	1519	0.89	1.19
850	1800	1302	0.67	0.9	1341	0.72	0.96	1377	0.76	1.02	1411	0.81	1.08	1444	0.86	1.15	1477	0.90	1.20	1510	0.93	1.25	1544	0.97	1.30
895	1900	1334	0.75	1.01	1371	0.80	1.07	1406	0.84	1.13	1439	0.90	1.20	1471	0.94	1.26	1504	0.98	1.32	1537	1.02	1.37	1571	1.05	1.41
945	2000	1365	0.84	1.12	1401	0.89	1.19	1435	0.93	1.25	1468	0.98	1.32	1500	1.03	1.38	1532	1.07	1.44	1565	1.11	1.49	1598	1.14	1.53

**BLOWER DATA**

**BELT DRIVE | 5 TON**

**BLOWER TABLE INCLUDES RESISTANCE FOR BASE UNIT ONLY WITH DRY INDOOR COIL AND AIR FILTERS IN PLACE. FOR ALL UNITS ADD:**

- 1 - Any factory installed options air resistance (heat section, economizer, wet coil, etc.).
  - 2 - Any field installed accessories air resistance (duct resistance, diffuser, etc.).
- See page 25 for blower motors and drives and wet coil and options/accessory air resistance data.

**DOWNFLOW**

Air Volume		External Static - Pa (in. w.g.)																							
		25 (0.10)		50 (0.20)		75 (0.30)		100 (0.40)		125 (0.50)		150 (0.60)		175 (0.70)		200 (0.80)									
L/s	cfm	Rev/min	kW	BHP	Rev/min	kW	BHP	Rev/min	kW	BHP	Rev/min	kW	BHP	Rev/min	kW	BHP	Rev/min	kW	BHP						
755	1600	764	0.34	0.46	823	0.38	0.51	882	0.42	0.56	940	0.45	0.60	997	0.48	0.65	1048	0.51	0.69	1094	0.54	0.72	1140	0.56	0.75
800	1700	806	0.40	0.53	863	0.43	0.58	919	0.46	0.62	975	0.50	0.67	1028	0.53	0.71	1075	0.56	0.75	1119	0.58	0.78	1164	0.60	0.81
850	1800	849	0.45	0.60	903	0.48	0.65	957	0.51	0.69	1010	0.55	0.74	1058	0.58	0.78	1102	0.61	0.82	1145	0.63	0.85	1189	0.66	0.88
895	1900	892	0.51	0.68	944	0.54	0.72	995	0.57	0.77	1045	0.61	0.82	1089	0.64	0.86	1131	0.66	0.89	1174	0.69	0.92	1217	0.71	0.95
945	2000	935	0.57	0.76	984	0.60	0.81	1033	0.64	0.86	1079	0.68	0.91	1122	0.71	0.95	1163	0.72	0.97	1204	0.75	1.00	1247	0.77	1.03
990	2100	977	0.63	0.85	1024	0.67	0.90	1070	0.71	0.95	1114	0.75	1.00	1155	0.77	1.03	1196	0.79	1.06	1237	0.81	1.09	1278	0.84	1.12
1040	2200	1018	0.71	0.95	1063	0.74	0.99	1107	0.78	1.04	1149	0.81	1.09	1190	0.84	1.12	1230	0.86	1.15	1270	0.88	1.18	1310	0.91	1.22
1085	2300	1057	0.78	1.04	1100	0.81	1.09	1143	0.85	1.14	1185	0.88	1.18	1225	0.91	1.22	1264	0.93	1.25	1303	0.96	1.29	1342	0.99	1.33
1135	2400	1096	0.85	1.14	1137	0.88	1.18	1179	0.92	1.23	1220	0.95	1.27	1260	0.98	1.31	1299	1.01	1.35	1337	1.04	1.40	1375	1.08	1.45

Air Volume		External Static - Pa (in. w.g.)																							
		225 (0.90)		250 (1.00)		275 (1.10)		300 (1.20)		325 (1.30)		350 (1.40)		375 (1.50)		400 (1.60)									
L/s	cfm	Rev/min	kW	BHP	Rev/min	kW	BHP	Rev/min	kW	BHP	Rev/min	kW	BHP	Rev/min	kW	BHP	Rev/min	kW	BHP						
755	1600	1185	0.59	0.79	1229	0.60	0.81	1271	0.63	0.84	1313	0.64	0.86	1354	0.67	0.9	1393	0.70	0.94	1431	0.73	0.98	1468	0.77	1.03
800	1700	1208	0.63	0.84	1252	0.65	0.87	1294	0.67	0.9	1335	0.70	0.94	1375	0.73	0.98	1413	0.76	1.02	1449	0.80	1.07	1485	0.84	1.12
850	1800	1233	0.68	0.91	1276	0.70	0.94	1318	0.73	0.98	1358	0.76	1.02	1397	0.79	1.06	1434	0.83	1.11	1469	0.87	1.16	1504	0.90	1.21
895	1900	1261	0.73	0.98	1303	0.76	1.02	1343	0.79	1.06	1382	0.83	1.11	1420	0.87	1.16	1455	0.90	1.21	1490	0.94	1.26	1525	0.98	1.31
945	2000	1289	0.80	1.07	1330	0.83	1.11	1370	0.87	1.16	1407	0.90	1.21	1444	0.95	1.27	1478	0.98	1.32	1513	1.02	1.37	1547	1.06	1.42
990	2100	1319	0.87	1.16	1359	0.90	1.21	1397	0.95	1.27	1433	0.98	1.32	1468	1.03	1.38	1502	1.07	1.44	1536	1.11	1.49	1570	1.14	1.53
1040	2200	1350	0.95	1.27	1388	0.98	1.32	1424	1.03	1.38	1459	1.08	1.45	1494	1.13	1.51	1527	1.16	1.56	1561	1.20	1.61	1594	1.23	1.65
1085	2300	1380	1.03	1.38	1417	1.08	1.45	1452	1.13	1.51	1486	1.18	1.58	1520	1.22	1.63	1553	1.25	1.68	1587	1.29	1.73	1620	1.33	1.78
1135	2400	1411	1.13	1.51	1446	1.18	1.58	1480	1.23	1.65	1514	1.28	1.71	1547	1.32	1.77	1580	1.35	1.81	1614	1.39	1.86	1648	1.42	1.90

**BLOWER DATA**

**BELT DRIVE | 5 TON**

**BLOWER TABLE INCLUDES RESISTANCE FOR BASE UNIT ONLY WITH DRY INDOOR COIL AND AIR FILTERS IN PLACE. FOR ALL UNITS ADD:**

1 - Any factory installed options air resistance (heat section, economizer, wet coil, etc.).

2 - Any field installed accessories air resistance (duct resistance, diffuser, etc.).

See page 25 for blower motors and drives and wet coil and options/accessory air resistance data.

**HORIZONTAL**

Air Volume		External Static - Pa (in. w.g.)																							
		25 (0.10)		50 (0.20)		75 (0.30)		100 (0.40)		125 (0.50)		150 (0.60)		175 (0.70)		200 (0.80)									
L/s	cfm	Rev/min	kW	BHP	Rev/min	kW	BHP	Rev/min	kW	BHP	Rev/min	kW	BHP	Rev/min	kW	BHP	Rev/min	kW	BHP						
755	1600	752	0.30	0.40	818	0.34	0.45	882	0.37	0.50	943	0.41	0.55	999	0.44	0.59	1050	0.46	0.62	1097	0.49	0.66	1142	0.51	0.69
800	1700	792	0.34	0.46	855	0.39	0.52	917	0.42	0.56	975	0.46	0.61	1028	0.48	0.64	1077	0.51	0.68	1123	0.54	0.72	1166	0.56	0.75
850	1800	832	0.40	0.53	894	0.43	0.58	952	0.47	0.63	1007	0.50	0.67	1058	0.52	0.70	1105	0.55	0.74	1149	0.58	0.78	1192	0.61	0.82
895	1900	873	0.45	0.60	932	0.48	0.65	988	0.51	0.69	1040	0.54	0.73	1088	0.57	0.77	1134	0.60	0.81	1177	0.63	0.85	1219	0.67	0.90
945	2000	914	0.50	0.67	970	0.54	0.72	1023	0.57	0.76	1073	0.60	0.80	1120	0.63	0.85	1163	0.66	0.89	1205	0.70	0.94	1246	0.74	0.99
990	2100	955	0.55	0.74	1009	0.59	0.79	1059	0.63	0.84	1107	0.66	0.89	1152	0.69	0.93	1194	0.73	0.98	1235	0.77	1.03	1275	0.81	1.09
1040	2200	995	0.62	0.83	1047	0.66	0.88	1095	0.69	0.93	1141	0.73	0.98	1184	0.77	1.03	1225	0.81	1.08	1265	0.85	1.14	1304	0.90	1.20
1085	2300	1036	0.69	0.92	1085	0.72	0.97	1132	0.76	1.02	1175	0.81	1.08	1217	0.84	1.13	1257	0.89	1.19	1296	0.94	1.26	1334	0.98	1.32
1135	2400	1077	0.75	1.01	1124	0.80	1.07	1168	0.84	1.13	1210	0.89	1.19	1251	0.93	1.25	1290	0.98	1.32	1328	1.04	1.39	1365	1.09	1.46

Air Volume		External Static - Pa (in. w.g.)																							
		225 (0.90)		250 (1.00)		275 (1.10)		300 (1.20)		325 (1.30)		350 (1.40)		375 (1.50)		400 (1.60)									
L/s	cfm	Rev/min	kW	BHP	Rev/min	kW	BHP	Rev/min	kW	BHP	Rev/min	kW	BHP	Rev/min	kW	BHP	Rev/min	kW	BHP						
755	1600	1185	0.54	0.72	1228	0.56	0.75	1270	0.59	0.79	1310	0.62	0.83	1349	0.66	0.88	1387	0.69	0.93	1423	0.73	0.98	1459	0.77	1.03
800	1700	1209	0.58	0.78	1251	0.61	0.82	1292	0.65	0.87	1331	0.69	0.92	1370	0.72	0.97	1407	0.76	1.02	1443	0.80	1.07	1478	0.84	1.12
850	1800	1234	0.64	0.86	1275	0.68	0.91	1315	0.72	0.96	1354	0.75	1.01	1391	0.79	1.06	1428	0.83	1.11	1463	0.87	1.17	1498	0.91	1.22
895	1900	1260	0.71	0.95	1300	0.75	1.00	1340	0.78	1.05	1377	0.83	1.11	1414	0.87	1.16	1450	0.91	1.22	1485	0.95	1.27	1519	0.98	1.32
945	2000	1287	0.78	1.04	1326	0.82	1.10	1365	0.87	1.16	1402	0.90	1.21	1437	0.95	1.27	1472	0.99	1.33	1507	1.03	1.38	1541	1.07	1.43
990	2100	1314	0.86	1.15	1353	0.90	1.21	1391	0.95	1.27	1427	0.99	1.33	1462	1.04	1.39	1496	1.07	1.44	1530	1.12	1.50	1564	1.16	1.55
1040	2200	1343	0.94	1.26	1381	0.99	1.33	1417	1.04	1.39	1453	1.08	1.45	1487	1.13	1.51	1521	1.16	1.56	1555	1.21	1.62	1589	1.25	1.67
1085	2300	1372	1.04	1.39	1409	1.08	1.45	1445	1.13	1.52	1480	1.18	1.58	1513	1.22	1.64	1547	1.26	1.69	1580	1.31	1.75	1614	1.34	1.80
1135	2400	1402	1.13	1.52	1438	1.19	1.59	1473	1.23	1.65	1507	1.28	1.71	1541	1.32	1.77	1574	1.37	1.83	1607	1.40	1.88	1641	1.44	1.93

**BLOWER DATA**

**BLOWER TABLE INCLUDES RESISTANCE FOR BASE UNIT ONLY WITH DRY INDOOR COIL AND AIR FILTERS IN PLACE.**

FOR ALL UNITS ADD:

1 - Any factory installed options air resistance (heat section, economizer, wet coil, etc.).

2 - Any field installed accessories air resistance (duct resistance, diffuser, etc.).

See page 25 for blower motors and drives and wet coil and options/accessory air resistance data.

**DOWNFLOW**

**External Static - Pa (in.w.g.)**

Air Volume		25 (0.10)			50 (0.20)			75 (0.30)			100 (0.40)			125 (0.50)			150 (0.60)			175 (0.70)			200 (0.80)		
		Rev/ min	kW	BHP	Rev/ min	kW	BHP	Rev/ min	kW	BHP	Rev/ min	kW	BHP	Rev/ min	kW	BHP	Rev/ min	kW	BHP	Rev/ min	kW	BHP	Rev/ min	kW	BHP
L/s	cfm																								
900	1900	578	0.33	0.44	610	0.37	0.49	643	0.40	0.54	678	0.45	0.60	714	0.48	0.65	749	0.52	0.70	785	0.57	0.76	819	0.61	0.82
945	2000	600	0.37	0.50	632	0.42	0.56	665	0.46	0.61	699	0.49	0.66	734	0.53	0.71	769	0.57	0.77	803	0.62	0.83	837	0.67	0.90
990	2100	623	0.43	0.57	655	0.46	0.62	688	0.51	0.68	721	0.54	0.73	755	0.59	0.79	789	0.63	0.84	822	0.68	0.91	854	0.73	0.98
1040	2200	647	0.48	0.65	678	0.52	0.70	711	0.56	0.75	743	0.60	0.81	776	0.64	0.86	809	0.69	0.93	841	0.75	1.00	872	0.79	1.06
1085	2300	671	0.54	0.73	702	0.58	0.78	734	0.62	0.83	766	0.66	0.89	798	0.71	0.95	829	0.76	1.02	860	0.81	1.09	890	0.87	1.16
1135	2400	696	0.60	0.81	726	0.65	0.87	757	0.69	0.92	788	0.73	0.98	819	0.78	1.04	850	0.83	1.11	880	0.89	1.19	909	0.94	1.26
1180	2500	720	0.67	0.90	750	0.71	0.95	780	0.75	1.01	811	0.80	1.07	841	0.85	1.14	871	0.91	1.22	900	0.97	1.30	929	1.02	1.37
1225	2600	745	0.74	0.99	774	0.78	1.05	804	0.83	1.11	834	0.87	1.17	864	0.93	1.25	893	0.99	1.33	921	1.05	1.41	949	1.11	1.49
1275	2700	770	0.81	1.09	799	0.86	1.15	828	0.90	1.21	858	0.95	1.28	887	1.01	1.36	916	1.07	1.44	943	1.14	1.53	969	1.20	1.61
1320	2800	795	0.89	1.19	824	0.93	1.25	853	0.99	1.33	882	1.04	1.40	911	1.10	1.48	939	1.16	1.56	965	1.23	1.65	990	1.29	1.73
1370	2900	820	0.97	1.30	849	1.02	1.37	878	1.08	1.45	907	1.14	1.53	935	1.20	1.61	962	1.27	1.70	988	1.33	1.78	1012	1.39	1.86

**External Static - Pa (in.w.g.)**

Air Volume		820			250 (1.00)			275 (1.10)			300 (1.20)			325 (1.30)			350 (1.40)			375 (1.50)			400 (1.60)		
		Rev/ min	kW	BHP	Rev/ min	kW	BHP	Rev/ min	kW	BHP	Rev/ min	kW	BHP	Rev/ min	kW	BHP	Rev/ min	kW	BHP	Rev/ min	kW	BHP	Rev/ min	kW	BHP
L/s	cfm																								
900	1900	853	0.66	0.88	885	0.70	0.94	915	0.74	0.99	944	0.78	1.05	971	0.83	1.11	996	0.87	1.17	1021	0.92	1.23	1045	0.96	1.29
945	2000	869	0.72	0.96	899	0.75	1.01	929	0.80	1.07	957	0.84	1.13	984	0.89	1.19	1009	0.93	1.25	1033	0.98	1.31	1058	1.03	1.38
990	2100	885	0.78	1.04	915	0.82	1.10	944	0.86	1.15	971	0.91	1.22	997	0.95	1.28	1022	1.00	1.34	1046	1.04	1.40	1070	1.09	1.46
1040	2200	902	0.84	1.13	931	0.89	1.19	959	0.93	1.24	986	0.98	1.31	1012	1.02	1.37	1036	1.07	1.43	1060	1.12	1.50	1084	1.16	1.56
1085	2300	920	0.92	1.23	948	0.96	1.29	975	1.01	1.35	1001	1.05	1.41	1027	1.10	1.47	1051	1.14	1.53	1075	1.19	1.60	1098	1.24	1.66
1135	2400	938	0.99	1.33	965	1.04	1.39	992	1.08	1.45	1017	1.13	1.52	1042	1.18	1.58	1066	1.22	1.64	1090	1.27	1.70	1113	1.32	1.77
1180	2500	956	1.07	1.44	983	1.13	1.51	1009	1.17	1.57	1034	1.22	1.63	1059	1.26	1.69	1082	1.31	1.75	1105	1.36	1.82	1128	1.40	1.88
1225	2600	975	1.16	1.56	1001	1.22	1.63	1026	1.26	1.69	1051	1.31	1.75	1075	1.35	1.81	1098	1.40	1.87	1121	1.44	1.93	1143	1.49	2.00
1275	2700	995	1.25	1.68	1020	1.31	1.75	1044	1.35	1.81	1069	1.40	1.87	1092	1.44	1.93	1114	1.48	1.99	1136	1.54	2.06	1158	1.59	2.13
1320	2800	1015	1.35	1.81	1039	1.40	1.87	1063	1.45	1.94	1086	1.49	2.00	1109	1.54	2.06	1131	1.58	2.12	1152	1.63	2.19	1174	1.69	2.26
1370	2900	1035	1.45	1.94	1058	1.49	2.00	1081	1.54	2.07	1104	1.59	2.13	1126	1.63	2.19	1147	1.69	2.26	1168	1.74	2.33	1189	1.79	2.40

**BLOWER TABLE INCLUDES RESISTANCE FOR BASE UNIT ONLY WITH DRY INDOOR COIL AND AIR FILTERS IN PLACE.**

FOR ALL UNITS ADD:

1 - Any factory installed options air resistance (heat section, economizer, wet coil, etc.).

2 - Any field installed accessories air resistance (duct resistance, diffuser, etc.).

See page 25 for blower motors and drives and wet coil and options/accessory air resistance data.

**HORIZONTAL**

Air Volume		External Static - Pa (in.w.g.)																							
		25 (0.10)		50 (0.20)		75 (0.30)		100 (0.40)		125 (0.50)		150 (0.60)		175 (0.70)		200 (0.80)									
L/s	cfm	Rev/min	kW	BHP	Rev/min	kW	BHP	Rev/min	kW	BHP	Rev/min	kW	BHP	Rev/min	kW	BHP	Rev/min	kW	BHP						
900	1900	581	0.33	0.44	618	0.37	0.49	655	0.40	0.54	692	0.44	0.59	729	0.48	0.64	765	0.51	0.69	800	0.56	0.75	833	0.60	0.80
945	2000	602	0.37	0.50	639	0.41	0.55	676	0.46	0.61	713	0.49	0.66	749	0.53	0.71	784	0.57	0.76	818	0.61	0.82	850	0.66	0.88
990	2100	625	0.43	0.57	661	0.46	0.62	698	0.50	0.67	735	0.54	0.73	770	0.58	0.78	804	0.63	0.84	837	0.67	0.90	868	0.72	0.96
1040	2200	648	0.48	0.64	685	0.51	0.69	721	0.56	0.75	757	0.60	0.80	791	0.64	0.86	824	0.69	0.92	856	0.73	0.98	886	0.78	1.05
1085	2300	673	0.53	0.71	709	0.57	0.77	745	0.62	0.83	780	0.66	0.88	813	0.70	0.94	845	0.75	1.01	876	0.81	1.08	905	0.86	1.15
1135	2400	699	0.59	0.79	734	0.63	0.85	769	0.68	0.91	803	0.72	0.97	835	0.78	1.04	866	0.83	1.11	896	0.88	1.18	924	0.93	1.25
1180	2500	725	0.66	0.88	759	0.70	0.94	793	0.75	1.00	826	0.80	1.07	857	0.85	1.14	887	0.90	1.21	916	0.95	1.28	944	1.01	1.36
1225	2600	752	0.72	0.97	785	0.78	1.04	818	0.82	1.10	850	0.87	1.17	880	0.93	1.25	909	0.98	1.32	937	1.04	1.40	964	1.10	1.48
1275	2700	779	0.80	1.07	811	0.85	1.14	843	0.90	1.21	873	0.96	1.29	902	1.02	1.37	931	1.07	1.44	958	1.13	1.52	984	1.19	1.60
1320	2800	805	0.88	1.18	837	0.94	1.26	868	0.99	1.33	897	1.05	1.41	925	1.11	1.49	952	1.17	1.57	979	1.24	1.66	1004	1.30	1.74
1370	2900	832	0.97	1.30	863	1.03	1.38	892	1.09	1.46	921	1.15	1.54	948	1.22	1.63	974	1.28	1.71	1000	1.34	1.80	1024	1.40	1.88

Air Volume		External Static - Pa (in.w.g.)																							
		225 (0.90)		250 (1.00)		275 (1.10)		300 (1.20)		325 (1.30)		350 (1.40)		375 (1.50)		400 (1.60)									
L/s	cfm	Rev/min	kW	BHP	Rev/min	kW	BHP	Rev/min	kW	BHP	Rev/min	kW	BHP	Rev/min	kW	BHP	Rev/min	kW	BHP						
900	1900	864	0.65	0.87	895	0.69	0.93	924	0.74	0.99	953	0.79	1.06	980	0.84	1.12	1007	0.88	1.18	1032	0.93	1.25	1056	0.98	1.31
945	2000	881	0.71	0.95	911	0.75	1.01	940	0.81	1.08	967	0.85	1.14	994	0.90	1.21	1020	0.95	1.27	1044	1.00	1.34	1068	1.04	1.40
990	2100	898	0.77	1.03	927	0.82	1.10	955	0.87	1.17	982	0.92	1.23	1008	0.97	1.30	1033	1.02	1.37	1057	1.07	1.43	1080	1.12	1.50
1040	2200	916	0.84	1.12	944	0.89	1.19	971	0.94	1.26	998	0.99	1.33	1023	1.04	1.40	1047	1.10	1.47	1071	1.15	1.54	1093	1.19	1.60
1085	2300	934	0.91	1.22	961	0.96	1.29	988	1.01	1.36	1014	1.07	1.43	1038	1.12	1.50	1062	1.18	1.58	1085	1.23	1.65	1107	1.28	1.71
1135	2400	952	0.98	1.32	979	1.04	1.40	1005	1.10	1.47	1030	1.15	1.54	1054	1.21	1.62	1077	1.26	1.69	1099	1.31	1.76	1121	1.37	1.83
1180	2500	971	1.07	1.43	997	1.13	1.51	1022	1.19	1.59	1046	1.24	1.66	1069	1.30	1.74	1092	1.35	1.81	1114	1.40	1.88	1135	1.45	1.95
1225	2600	990	1.16	1.55	1015	1.22	1.63	1039	1.28	1.71	1063	1.34	1.79	1086	1.39	1.86	1108	1.45	1.94	1129	1.50	2.01	1150	1.54	2.07
1275	2700	1009	1.25	1.68	1034	1.31	1.76	1057	1.37	1.84	1080	1.43	1.92	1102	1.48	1.99	1124	1.54	2.07	1145	1.60	2.14	1166	1.65	2.21
1320	2800	1028	1.36	1.82	1052	1.42	1.90	1075	1.48	1.98	1097	1.54	2.06	1119	1.59	2.13	1140	1.65	2.21	1161	1.70	2.28	1182	1.75	2.34
1370	2900	1048	1.46	1.96	1071	1.52	2.04	1093	1.58	2.12	1115	1.64	2.20	1136	1.70	2.28	1157	1.75	2.35	1177	1.81	2.42	1198	1.85	2.48



## BLOWER DATA

### BELT DRIVE KIT SPECIFICATIONS - 036-060

Model No.	Motor kW (HP)		No. of Speeds	Drive Kits and Rev/Min Range					
	Nominal	Maximum		ZA07	ZA08	ZA09	ZA10	<sup>1</sup> ZA11	<sup>2</sup> ZA12
036	0.62 (0.83)	0.71 (0.95)	1	705 - 1077	---	---	1025 - 1391	---	---
	0.93 (1.25)	1.07 (1.43)	1	705 - 1077	---	---	1025 - 1391	---	---
048	0.62 (0.83)	0.71 (0.95)	1	---	759 - 1158	---	---	1111 - 1437	---
	0.93 (1.25)	1.07 (1.43)	1	---	759 - 1158	---	---	1111 - 1437	---
060	0.93 (1.25)	1.07 (1.43)	1	---	---	919 - 1247	---	---	1190 - 1540
	1.24 (1.66)	1.42 (1.91)	1	---	---	919 - 1247	---	---	1190 - 1540

NOTE - Using total air volume and system static pressure requirements determine from blower performance tables rev/min and motor size required. Maximum usable size of motors furnished are shown. If motors of comparable size are used, be sure to keep within the service factor limitations outlined on the motor nameplate.

<sup>1</sup> ZA11 drive kits require the 0.93 kW (1.25 hp) motor.

<sup>2</sup> ZA12 drive kit requires the 1.24 kW (1.66 hp) motor.

### BELT DRIVE KIT SPECIFICATIONS - 074

Model No.	Motor kW (HP)		No. of Speeds	Drive Kits and Rev/Min Range		
	Nominal	Maximum		ZAA03	ZAA04	ZAA05
074	1.24 (1.66)	1.42 (1.91)	2	665 - 921	768 - 1023	921 - 1177
	1.24 (1.66)	1.42 (1.91)	2	665 - 921	768 - 1023	921 - 1177

NOTE - Using total air volume and system static pressure requirements determine from blower performance tables rev/min and motor size required. Maximum usable size of motors furnished are shown. If motors of comparable size are used, be sure to keep within the service factor limitations outlined on the motor nameplate.

### POWER EXHAUST FAN PERFORMANCE

Return Air System Static Pressure			Air Volume Exhausted	
Pa	in. w.g.		L/s	cfm
0	0.00		880	1865
12	0.05		842	1785
25	0.10		807	1710
37	0.15		769	1630
50	0.20		729	1545
62	0.25		684	1450
75	0.30		637	1350
87	0.35		585	1240

### OPTIONS / ACCESSORIES AIR RESISTANCE

Air Volume						Electric Heat		Economizer			
		036, 048		060, 074				Downflow		Horizontal	
L/s	cfm	Pa	in. w.g.	Pa	in. w.g.	Pa	in. w.g.	Pa	in. w.g.	Pa	in. w.g.
425	900	2	0.01	---	---	12	0.05	7	0.03	10	0.04
472	1000	5	0.02	---	---	15	0.06	7	0.03	12	0.05
519	1100	5	0.02	---	---	20	0.08	10	0.04	12	0.05
566	1200	5	0.02	---	---	22	0.09	12	0.05	15	0.06
613	1300	7	0.03	---	---	30	0.12	12	0.05	17	0.07
661	1400	7	0.03	---	---	42	0.17	15	0.06	20	0.08
708	1500	10	0.04	---	---	55	0.22	17	0.07	20	0.08
755	1600	10	0.04	7	0.03	65	0.26	20	0.08	22	0.09
802	1700	12	0.05	7	0.03	75	0.30	22	0.09	25	0.10
849	1800	12	0.05	7	0.03	82	0.33	25	0.10	27	0.11
897	1900	15	0.06	10	0.04	82	0.33	27	0.11	30	0.12
944	2000	15	0.06	10	0.04	77	0.31	30	0.12	32	0.13
991	2100	---	---	12	0.05	67	0.27	32	0.13	35	0.14
1038	2200	---	---	12	0.05	72	0.29	35	0.14	37	0.15
1085	2300	---	---	12	0.05	77	0.31	37	0.15	40	0.16
1133	2400	---	---	15	0.06	80	0.32	40	0.16	45	0.18
1180	2500	---	---	15	0.06	85	0.34	45	0.18	47	0.19
1227	2600	---	---	17	0.07	94	0.38	47	0.19	50	0.20
1274	2700	---	---	17	0.07	104	0.42	50	0.20	52	0.21
1321	2800	---	---	17	0.07	112	0.45	55	0.22	57	0.23
1369	2900	---	---	20	0.08	122	0.49	57	0.23	60	0.24

## BLOWER DATA

### CEILING DIFFUSERS AIR RESISTANCE

Air Volume		RTD9-65S Step-Down Diffuser						FD9-65S Flush Diffuser		RTD11-95S Step-Down Diffuser						FD11-95S Flush Diffuser	
		2 Ends Open		1 Side & 2 Ends Open		All Ends & Sides Open				2 Ends Open		1 Side & 2 Ends Open		All Ends & Sides Open			
L/s	cfm	Pa	in. w.g.	Pa	in. w.g.	Pa	in. w.g.	Pa	in. w.g.	Pa	in. w.g.	Pa	in. w.g.	Pa	in. w.g.	Pa	in. w.g.
375	800	37	0.15	32	0.13	27	0.11	27	0.11	---	---	---	---	---	---	---	---
470	1000	47	0.19	40	0.16	35	0.14	35	0.14	---	---	---	---	---	---	---	---
565	1200	62	0.25	50	0.20	42	0.17	42	0.17	---	---	---	---	---	---	---	---
660	1400	82	0.33	65	0.26	50	0.20	50	0.20	---	---	---	---	---	---	---	---
755	1600	107	0.43	80	0.32	50	0.20	50	0.24	---	---	---	---	---	---	---	---
850	1800	139	0.56	99	0.40	75	0.30	75	0.30	32	0.13	27	0.11	22	0.09	22	0.09
945	2000	182	0.73	124	0.50	90	0.36	90	0.36	37	0.15	32	0.13	27	0.11	25	0.10
1040	2200	236	0.95	157	0.63	109	0.44	109	0.44	45	0.18	37	0.15	30	0.12	30	0.12
1130	2400	---	---	---	---	---	---	---	---	52	0.21	45	0.18	37	0.15	35	0.14
1225	2600	---	---	---	---	---	---	---	---	60	0.24	52	0.21	45	0.18	42	0.17
1320	2800	---	---	---	---	---	---	---	---	67	0.27	60	0.24	52	0.21	50	0.20
1415	3000	---	---	---	---	---	---	---	---	80	0.32	72	0.29	62	0.25	62	0.25
1510	3200	---	---	---	---	---	---	---	---	102	0.41	92	0.37	80	0.32	77	0.31
1605	3400	---	---	---	---	---	---	---	---	124	0.50	112	0.45	97	0.39	92	0.37
1700	3600	---	---	---	---	---	---	---	---	152	0.61	134	0.54	119	0.48	109	0.44

### CEILING DIFFUSER AIR THROW DATA

Air Volume		<sup>1</sup> Effective Throw			
Model No.		RTD9-65S		FD9-65S	
L/s	cfm	m	ft.	m	ft.
375	800	3 - 5	10 - 17	4 - 5	14 - 18
470	1000	3 - 5	10 - 17	5 - 6	15 - 20
565	1200	3 - 5	11 - 18	5 - 7	16 - 22
660	1400	4 - 6	12 - 19	5 - 7	17 - 24
755	1600	4 - 6	12 - 20	5 - 8	18 - 25
850	1800	4 - 6	13 - 21	6 - 9	20 - 28
945	2000	4 - 7	14 - 23	6 - 9	21 - 29
1040	2200	5 - 8	16 - 25	7 - 9	22 - 30
Model No.		RTD11-95S		FD11-95S	
1225	2600	7 - 9	24 - 29	6 - 7	19 - 24
1320	2800	8 - 9	25 - 30	6 - 9	20 - 28
1415	3000	8 - 10	27 - 33	6 - 9	21 - 29
1510	3200	9 - 11	28 - 35	7 - 9	22 - 29
1605	3400	9 - 11	30 - 37	7 - 9	22 - 30
1700	3600	8 - 10	25 - 33	7 - 8	22 - 24

<sup>1</sup> Effective throw based on terminal velocities of 23 m per minute ( 75 ft. per minute).

## ELECTRICAL DATA

Model No.		ZCB036S4	ZCB048S4	ZCB060S4	ZCB074S4	
<sup>1</sup> Voltage - 50hz with Neutral		380/420V - 3 Ph	380/420V - 3 Ph	380/420V - 3 Ph	380/420V - 3 Ph	
Compressor	Rated Load Amps	4	5.5	8	8.5	
	Locked Rotor Amps	31	37	59	66	
Outdoor Fan Motor	Full Load Amps	0.9	0.9	0.9	1	
Power Exhaust (1) 0.25 kW	Full Load Amps	0.6	0.6	0.6	1.3	
Indoor Blower Motor	kW	0.62	0.93	0.93	1.24	1.24
	Full Load Amps	1.6	2	2	2.6	2.6
<sup>2</sup> Maximum Overcurrent Protection	Unit Only	15	15	15	20	20
	With (1) 0.25 kW Power Exhaust	15	15	15	20	20
<sup>3</sup> Minimum Circuit Ampacity	Unit Only	8	8	10	13	14
	With (1) 0.25 kW Power Exhaust	9	9	10	11	15

## ELECTRIC HEAT DATA

Electric Heat Voltage			420V	420V	420V	420V	420V	420V	420V
<sup>2</sup> Maximum Overcurrent Protection	Unit+ <sup>4</sup> Electric Heat	3.8 kW	15	15	15	15	20	20	---
		5.7 kW	15	15	15	15	20	20	20
		7.7 kW	20	20	20	20	20	20	20
		11.5 kW	25	25	25	25	25	25	25
		17.2 kW	---	---	35	35	35	35	35
		23 kW	---	---	---	---	---	---	45
<sup>3</sup> Minimum Circuit Ampacity	Unit+ <sup>4</sup> Electric Heat	3.8 kW	9	10	10	10	13	14	---
		5.7 kW	12	13	12	13	13	14	15
		7.7 kW	16	16	16	16	16	17	17
		11.5 kW	22	23	22	23	23	24	23
		17.2 kW	---	---	32	33	33	34	33
		23 kW	---	---	---	---	---	---	43
<sup>2</sup> Maximum Overcurrent Protection	Unit+ <sup>4</sup> Electric Heat and (1) 0.25 kW Power Exhaust	3.8 kW	15	15	15	15	20	20	---
		5.7 kW	15	15	15	15	20	20	20
		7.7 kW	20	20	20	20	20	20	20
		11.5 kW	25	25	25	25	25	25	25
		17.2 kW	---	---	35	35	35	35	35
		23 kW	---	---	---	---	---	---	45
<sup>3</sup> Minimum Circuit Ampacity	Unit+ <sup>4</sup> Electric Heat and (1) 0.25 kW Power Exhaust	3.8 kW	10	10	10	11	14	15	---
		5.7 kW	13	14	13	14	14	15	16
		7.7 kW	16	17	16	17	17	18	19
		11.5 kW	23	23	23	23	23	25	25
		17.2 kW	---	---	33	33	33	34	35
		23 kW	---	---	---	---	---	---	45

## ELECTRIC HEAT ACCESSORIES

Unit Fuse Block	Unit Only	10A29	10A29	10A29	10A29	10A29	10A29	10A29
	Unit + Power Exhaust	10A29	10A29	10A29	10A29	10A29	10A29	10A29

<sup>1</sup> Extremes of operating range are plus and minus 10% of line voltage.

<sup>2</sup> Heating, Air Conditioning, Refrigeration type breaker or fuse.

<sup>3</sup> Refer to local electrical code to determine wire, fuse and disconnect size requirements.

<sup>4</sup> Nominal kW based on 420V-3ph-50hz.

## ELECTRIC HEAT CAPACITIES

Input Voltage	3.8 kW			5.7 kW			7.7 kW		
	No of Stages	kW input	Btuh Output	No of Stages	kW input	Btuh Output	No of Stages	kW input	Btuh Output
380	1	3.1	10 700	1	4.7	16 000	1	6.3	21 400
400	1	3.5	11 800	1	5.2	17 800	1	6.9	23 700
420	1	3.8	13 100	1	5.7	19 600	1	7.7	26 100
Input Voltage	11.5 kW			17.2 kW			23 kW		
	No of Stages	kW input	Btuh Output	No of Stages	kW input	Btuh Output	No of Stages	kW input	Btuh Output
380	1	9.4	32 100	1	14.1	48 100	1	18.8	64 200
400	1	10.4	35 500	1	15.6	53 300	1	20.9	71 200
420	1	11.5	39 200	1	17.2	58 800	1	23.0	78 500

## OUTDOOR SOUND DATA

Unit Model No.	Octave Band Sound Power Levels dB, re 10 <sup>-12</sup> Watts - Center Frequency - Hz							<sup>1</sup> Sound Rating Number (dBA)
	125	250	500	1000	2000	4000	8000	
ZCB036	81	78	77	72	68	66	61	77
ZCB048	84	80	79	74	70	67	63	80
ZCB060	80	76	76	73	68	66	64	78
ZCB074	88	85	84	79	72	66	64	84

<sup>1</sup> Sound Rating Number according to AHRI Standard 270-2008. Sound Rating Number is the overall A-Weighted Sound Power Level, (LWA), dB (100 Hz to 10,000 Hz).

## UNIT CLEARANCES

### UNIT WITH DOWNFLOW ECONOMIZER

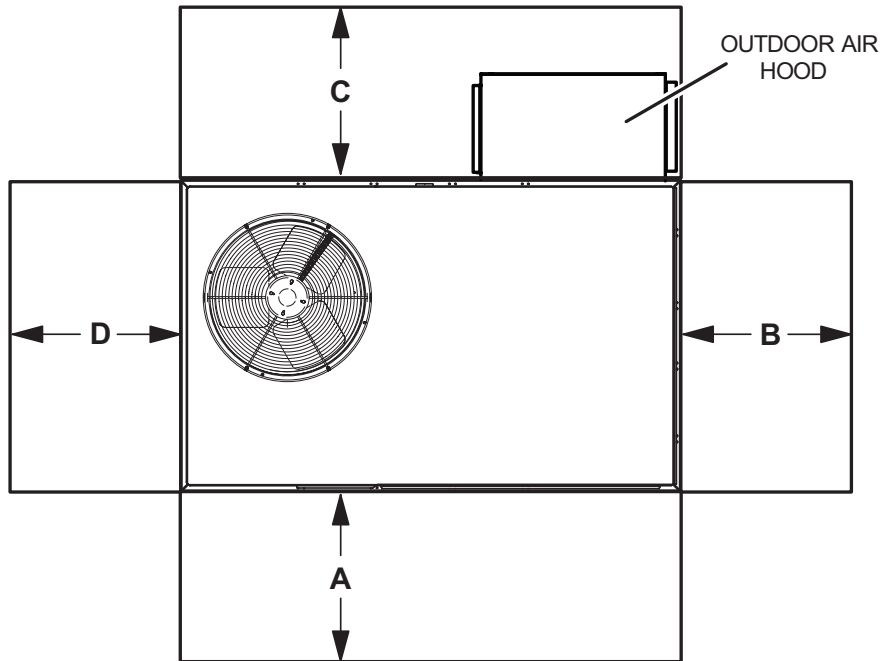

### UNIT WITH HORIZONTAL ECONOMIZER

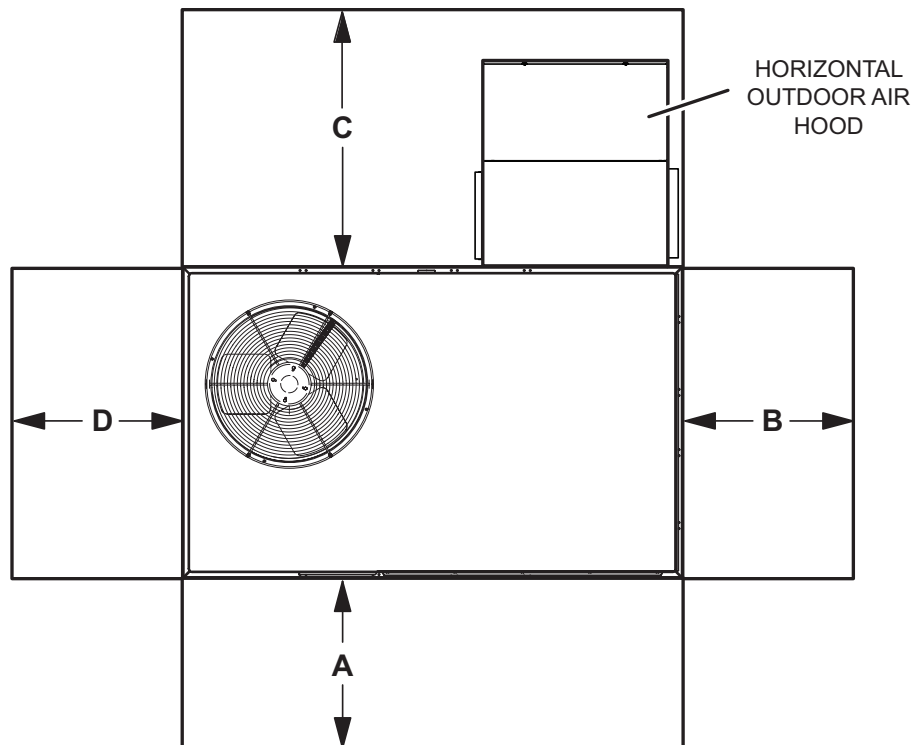

1 Unit Clearance	A		B		C Downflow		C Horizontal		D		Top Clearance
	mm	in.	mm	in.	mm	in.	mm	in.	mm	in.	
<b>Service Clearance</b>	914	36	914	36	914	36	1524	60	914	36	<b>Unobstructed</b>
<b>Minimum Operation Clearance</b>	914	36	914	36	914	36	1524	60	914	36	

NOTE - Entire perimeter of unit base requires support when elevated above the mounting surface.

<sup>1</sup> Service Clearance - Required for removal of serviceable parts.

Minimum Operation Clearance - Required clearance for proper unit operation.

**WEIGHT DATA**
**UNIT**

Model Number	Net				Shipping			
	Base		Max.		Base		Max.	
	kg	lbs.	kg	lbs.	kg	lbs.	kg	lbs.
<b>ZCB036S</b>	215	474	247	544	217	479	249	549
<b>ZCB048S</b>	219	483	251	553	221	488	253	558
<b>ZCB060S</b>	258	568	290	640	260	573	293	645
<b>ZCB074S</b>	258	568	282	621	260	573	284	626

Base Unit - The unit with NO OPTIONS.

Max. Unit - The unit with ALL OPTIONS Installed. (Economizer, etc.)

**WEIGHT DATA**
**OPTIONS / ACCESSORIES**

		Shipping Weights	
		kg	lbs.
<b>ECONOMIZER</b>			
<b>Economizer</b>			
Economizer, Includes Outdoor Air Hood and Barometric Relief Dampers with Hood	Downflow	34	75
	Horizontal	46	102
<b>OUTDOOR AIR</b>			
<b>Outdoor Air Dampers</b>			
Motorized		18	39
Manual		13	29
<b>POWER EXHAUST</b>			
Standard Static	Downflow	24	54
	Horizontal	19	41
<b>ELECTRIC HEAT</b>			
3.8 kW		11	25
5.7 kW		12	26
7.7 kW		12	27
11.5 kW		12	27
17.2 kW		13	29
23 kW		14	30
<b>ROOF CURBS</b>			
<b>Hybrid Roof Curbs, Downflow</b>			
203 mm		29	63
356 mm		38	83
457 mm		42	93
610 mm		51	113
<b>CEILING DIFFUSERS</b>			
Step-Down	RTD9-65S	36	80
	RTD11-95S	54	118
Flush	FD9-65S	36	80
	FD11-95S	54	118

# DIMENSIONS

# UNIT

Model No.	CORNER WEIGHTS																CENTER OF GRAVITY							
	AA				BB				CC				DD				EE				FF			
	Base		Max.		Base		Max.		Base		Max.		Base		Max.		Base		Max.		Base		Max.	
	kg	lbs.	kg	lbs.	kg	lbs.	kg	lbs.	kg	lbs.	kg	lbs.	kg	lbs.	kg	lbs.	mm	in.	mm	in.	mm	in.	mm	in.
036	53	117	61	134	51	112	59	129	54	120	63	138	57	125	65	143	984	38.75	933	36.75	578	22.75	622	24.5
048	54	119	62	136	52	115	59	131	55	122	64	140	58	127	66	145	984	38.75	933	36.75	578	22.75	622	24.5
060	71	156	80	176	64	140	72	158	59	129	66	145	65	143	73	161	1016	40	965	38	622	24.5	660	26
074	62	136	68	149	62	136	68	149	67	148	73	162	67	148	73	162	965	38	914	36	572	22.5	610	24

Base Unit - The unit with NO OPTIONS.

Max. Unit - The unit with ALL OPTIONS Installed. (Economizer, largest blower motor, etc.).

## BOTTOM POWER ENTRY

Holes required for Optional Bottom Power Entry Kit

	Threaded Conduit Fittings (Provided in Kit)	Wire Use	Hole Diameter Required in Unit Base (Max.)
A	1/2	ACC	23 (7/8)
B	1/2	24V	23 (7/8)
C	3/4	POWER	29 (1-1/8)

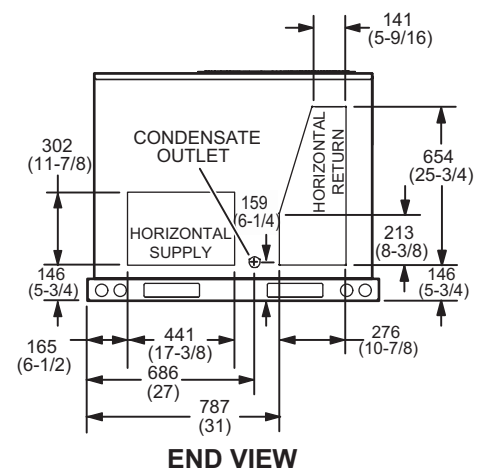
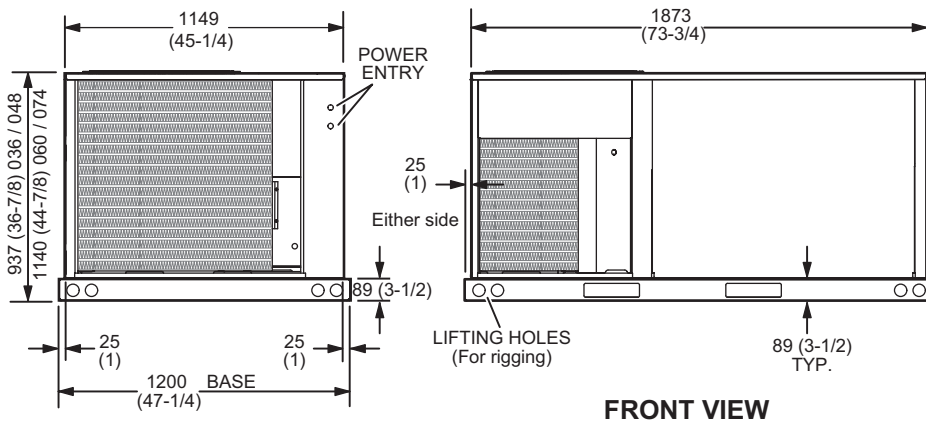
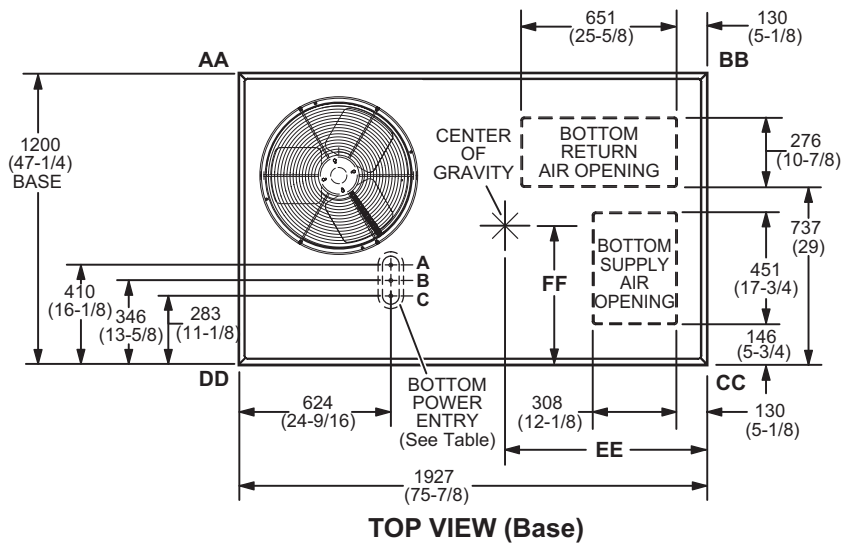

**OUTDOOR AIR HOOD DETAIL FOR OPTIONAL ECONOMIZER  
(Downflow Applications)**

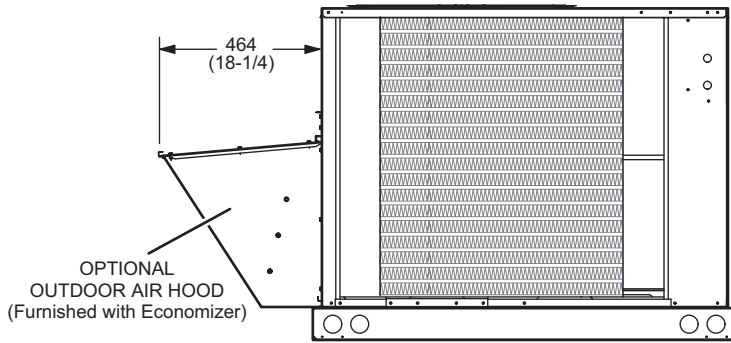

**SIDE VIEW**

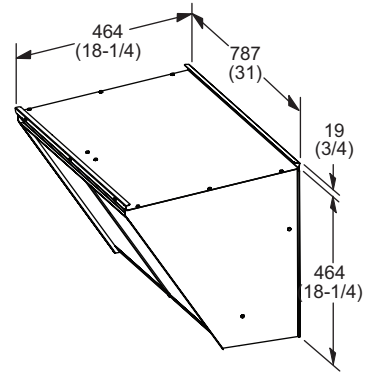

**OUTDOOR AIR DAMPER HOOD DETAIL (Downflow or Horizontal Applications)**

**MANUAL OUTDOOR AIR DAMPER HOOD**

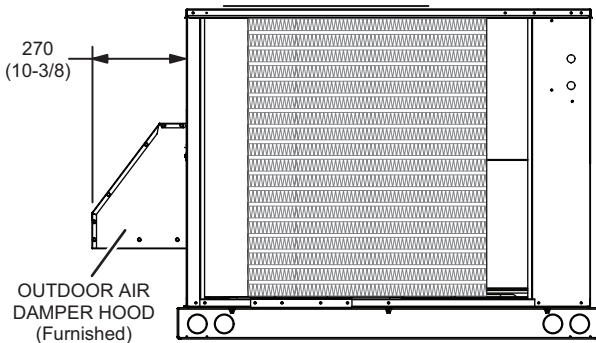

**END VIEW**

**MOTORIZED OUTDOOR AIR DAMPER HOOD**

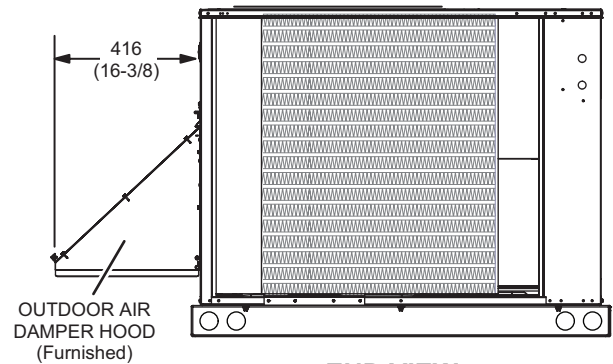

**END VIEW**

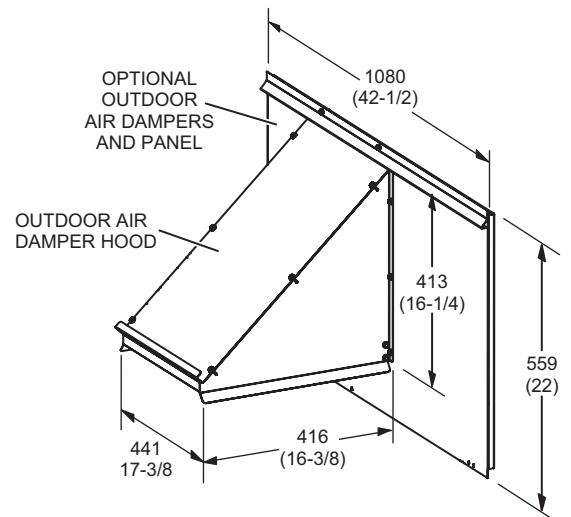
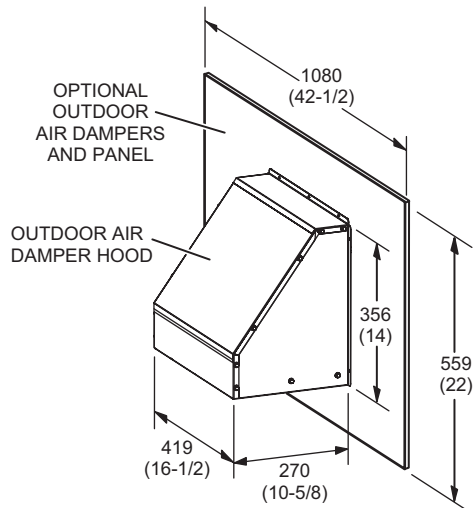



**OUTDOOR AIR HOOD DETAIL WITH OPTIONAL ECONOMIZER AND BAROMETRIC RELIEF DAMPERS  
(Horizontal Applications)**

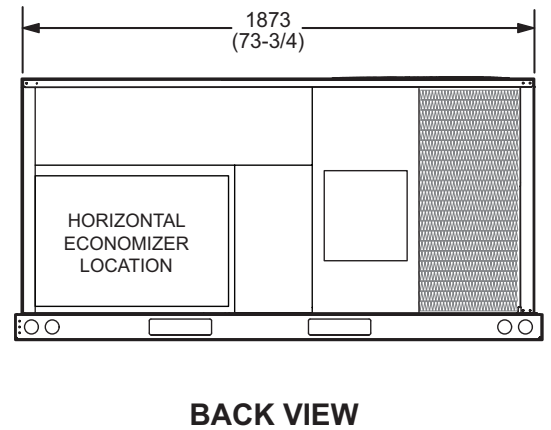
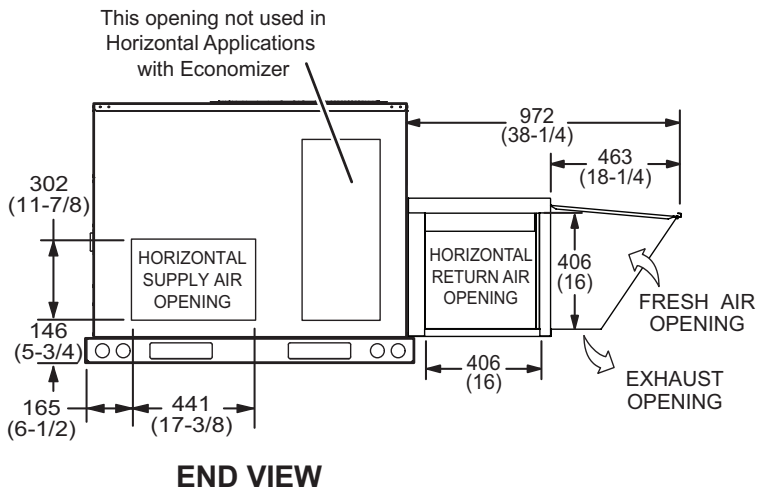
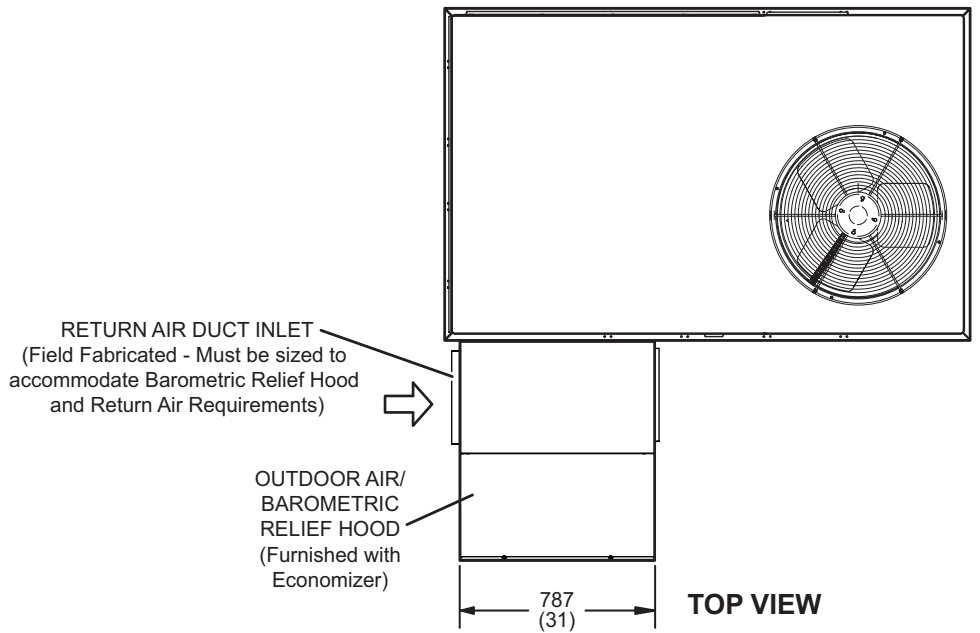

Note - Return Air Duct and Transition must be supported.

**HYBRID ROOF CURBS - DOUBLE DUCT OPENING**

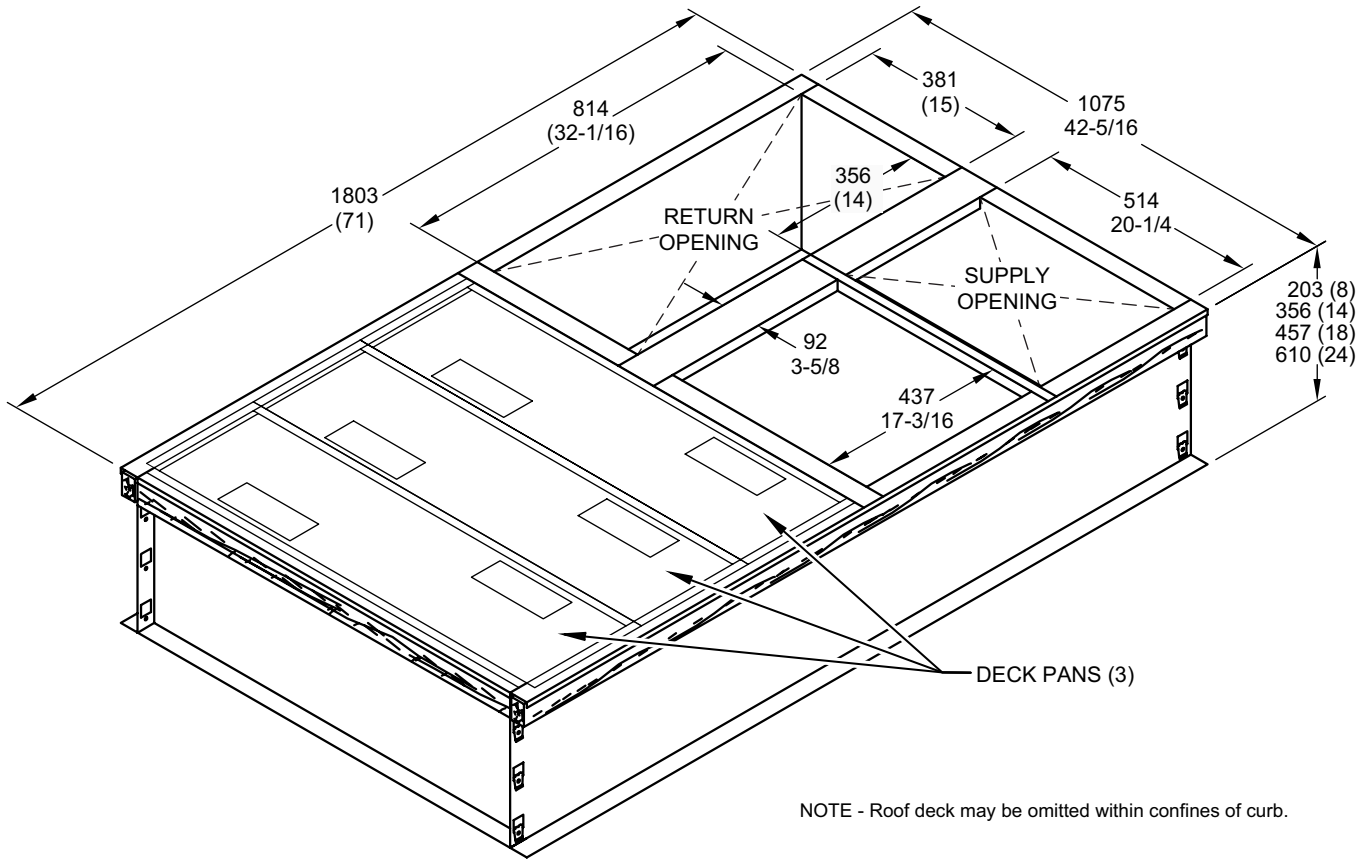

NOTE - Roof deck may be omitted within confines of curb.

**TYPICAL FLASHING DETAIL FOR ROOF CURB**

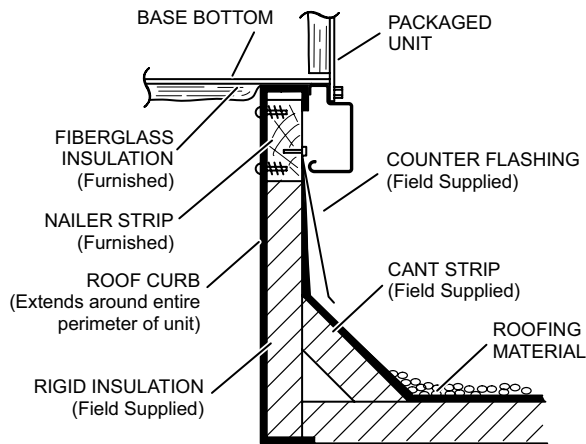

**DETAIL ROOF CURB**

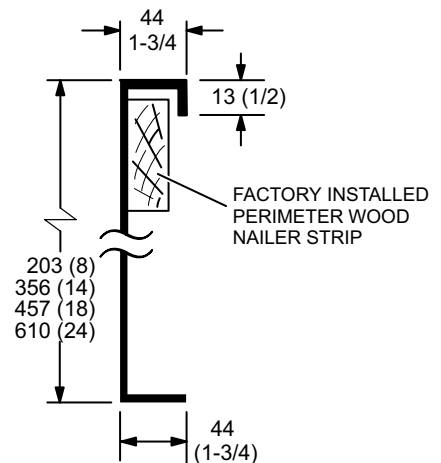

**COMBINATION CEILING SUPPLY AND RETURN DIFFUSERS**

**STEP-DOWN CEILING DIFFUSER**

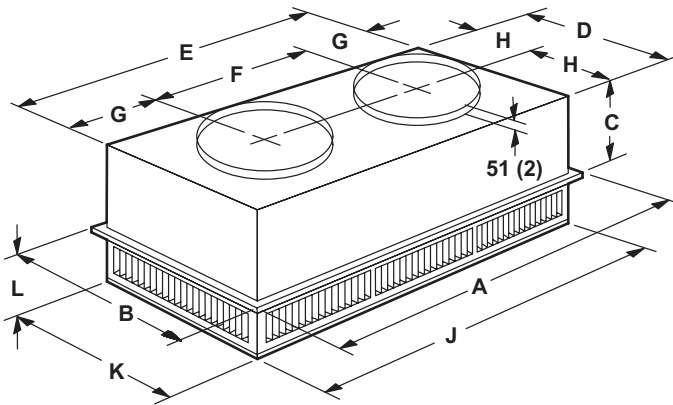

**FLUSH CEILING DIFFUSER**

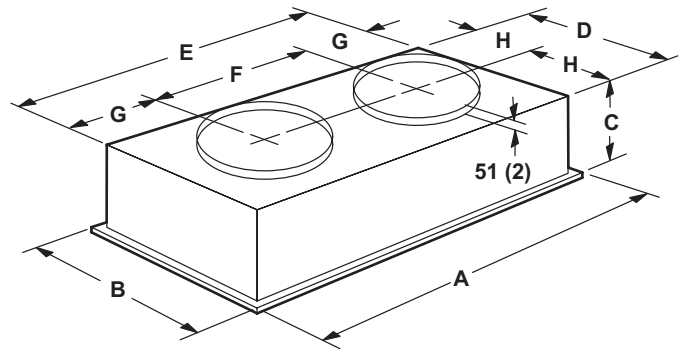

Model Number		RTD9-65S	RTD11-95S
<b>A</b>	mm	1159	1159
	in.	47-5/8	47-5/8
<b>B</b>	mm	600	752
	in.	23-5/8	29-5/8
<b>C</b>	mm	289	365
	in.	11-3/8	14-3/8
<b>D</b>	mm	546	699
	in.	21-1/2	27-1/2
<b>E</b>	mm	1156	1158
	in.	45-1/2	45-1/2
<b>F</b>	mm	572	572
	in.	22-1/2	22-1/2
<b>G</b>	mm	292	292
	in.	11-1/2	11-1/2
<b>H</b>	mm	273	349
	in.	10-3/4	13-3/4
<b>J</b>	mm	1156	1156
	in.	45-1/2	45-1/2
<b>K</b>	mm	546	699
	in.	21-1/2	27-1/2
<b>L</b>	mm	181	206
	in.	7-1/8	8-1/8
<b>Duct Size</b>	mm	457 round	508 round
	in.	18 round	20 round

Model Number		FD9-65S	FD11-95S
<b>A</b>	mm	1159	1159
	in.	47-5/8	47-5/8
<b>B</b>	mm	600	752
	in.	23-5/8	29-5/8
<b>C</b>	mm	343	422
	in.	13-1/2	16-5/8
<b>D</b>	mm	533	686
	in.	21	27
<b>E</b>	mm	1143	1143
	in.	45	45
<b>F</b>	mm	572	572
	in.	22-1/2	22-1/2
<b>G</b>	mm	286	286
	in.	11-1/4	11-1/4
<b>H</b>	mm	267	343
	in.	10-1/2	13-1/2
<b>Duct Size</b>	mm	457 round	20 round
	in.	18 round	508 round

## REVISIONS

Sections	Description of Change
Options/Accessories	<b>Catalog numbers revised for:</b> Single Enthalpy



Visit us at [www.lennox.com](http://www.lennox.com)

For the latest technical information, [www.lennoxcommercial.com](http://www.lennoxcommercial.com)

Contact us at 1-800-4-LENNOX

NOTE - Due to our' ongoing commitment to quality, Specifications, Ratings and Dimensions subject to change without notice and without incurring liability.  
Improper installation, adjustment, alteration, service or maintenance can cause property damage or personal injury.  
Installation and service must be performed by a qualified installer and servicing agency.

©2021 Lennox Industries, Inc.