

LRP14HP/LRP14DF/LRP14AC/LRP14GE/LRP16GE/LRP16HP SERIES UNITS

The LRP14/16 series packaged units are available in sizes ranging from 2 through 5 tons (7.0 through 17.6 kW). The LRP14/16 unit is designed for HFC-410A refrigerant and for outdoor residential use only. Units can be installed at ground level or on rooftops. The LRP14 units utilize a scroll compressor. LRP16GE/HP units utilize a two-stage compressor.

Information contained in this manual is intended for use by qualified service technicians only. All specifications are subject to change. Procedures outlined in this manual are presented as a recommendation only and do not supersede or replace local or state codes.

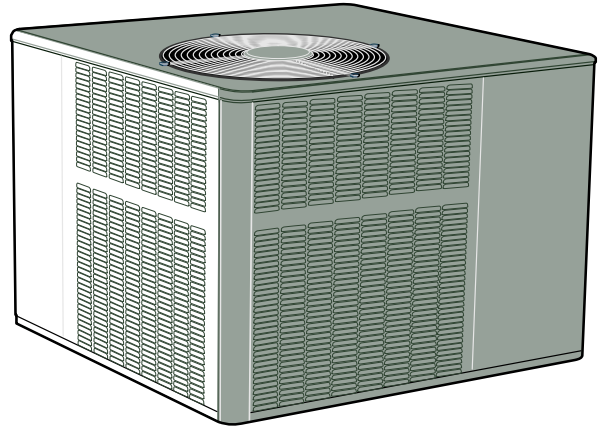

⚠ WARNING

Improper installation, adjustment, alteration, service or maintenance can cause personal injury, loss of life, or damage to property.

Installation and service must be performed by a licensed professional installer (or equivalent), service agency or the gas supplier.

⚠ IMPORTANT

Operating pressures and pressure switch settings in HFC-410A units are higher than pressures and switch settings in HCFC-22 units. Always use service equipment rated for HFC-410A if servicing a HFC-410A unit.

**ELECTROSTATIC DISCHARGE (ESD)
Precautions and Procedures**

⚠ CAUTION

Electrostatic discharge can affect electronic components. Take precautions during unit installation and service to protect the unit's electronic controls. Precautions will help to avoid control exposure to electrostatic discharge by putting the unit, the control and the technician at the same electrostatic potential. Neutralize electrostatic charge by touching hand and all tools on an unpainted unit surface before performing any service procedure.

TABLE OF CONTENTS

Specifications	2
Electric Heat Capacities / Electrical Data	3
Parts Arrangement	8
I Application	9
II Unit Components	10
III Electric Heat	21
IV Charging	22
VI Blower Data	18
VII Maintenance	29
VIII Wiring Diagrams and Sequence of Operation ..	36

SPECIFICATIONS — LRP14 HP and DF Models

General Data		Model No.	LRP14HP LRP14DF -24	LRP14HP LRP14DF -30	LRP14HP LRP14DF -36	LRP14HP LRP14DF -42	LRP14HP LRP14DF -48	LRP14HP LRP14DF -60	
Nominal Tonnage			2	2.5	3	3.5	4	5	
Cooling/ Heating Performance	Cooling	Total Capacity - Btuh	22,600	28,600	34,000	40,000	46,000	57,000	
		Total unit watts - DF only	2055	2600	3090	3635	4180	5180	
		¹ SEER (Btuh/Watt)	14.0	14.0	14.0	14.0	14.0	14.0	
		EER (Btuh/Watt)	11.0	11.0	11.0	11.0	11.0	11.0	
	High Temp Heat	Total Capacity - Btuh	22,000	27,000	33,400	39,000	45,000	56,000	
		Total unit watts	1700	2140	2645	3175	3565	4440	
		COP	3.8	3.7	3.7	3.6	3.7	3.7	
		HSPF - Region IV / Region V	8.0 / 6.95	8.0 / 6.95	8.0 / 6.95	8.0 / 6.95	8.0 / 6.95	8.0 / 6.95	
	Low Temp Heat	Total Capacity - Btuh	12,300	15,900	20,000	23,600	27,000	33,600	
		Total unit watts	1570	2025	2550	3010	3445	4105	
COP		2.3	2.3	2.3	2.3	2.3	2.4		
² Sound Rating Number (dB)			78	78	78	78	78	78	
Refrigerant Type			HFC-410A	HFC-410A	HFC-410A	HFC-410A	HFC-410A	HFC-410A	
Refrigerant Charge			5 lbs. 11 oz.	6 lbs. 0 oz.	5 lbs. 12 oz.	10 lbs. 5 oz.	10 lbs. 3 oz.	10 lbs. 1 oz.	
Gas Heat Available — Dual Fuel Models Only			-072(X)	-072(X)	-072(X), -090	-072(X), -090	-126(X)	-126(X)	
Outdoor Coil	Net face area - sq. ft.		16.4	16.4	16.4	16.6	16.6	16.6	
	Tube dia. - in. & No. of rows		5/16 - 1	5/16 - 1	5/16 - 1	5/16 - 2	5/16 - 2	5/16 - 2	
	Fins per inch		22	22	22	22	22	22	
Outdoor Coil Fan	Diameter - in. & No. of blades		22 - 4	22 - 4	22 - 4	24 - 3	24 - 3	24 - 3	
	Motor horsepower		1/6	1/6	1/6	1/4	1/4	1/4	
Indoor Coil	Net face area - sq. ft.		4.4	4.4	4.4	6.8	6.8	6.8	
	Tube dia. - in. & No. of rows		5/16 - 3	3/8 - 3	3/8 - 3	3/8 - 3	3/8 - 3	3/8 - 3	
	Fins per inch		15	15	15	15	15	15	
Indoor Blower	Blower wheel size dia. x width - in.		10 x 6	10 x 6	10 x 8	10 x 10	10 x 10	12 x 9	
	Motor horsepower		1/4	1/4	1/3	1/3	1/2	1	
Net weight of basic unit			333	342	352	455	460	482	
Shipping weight of basic unit (1 Pkg.)			396	405	415	528	533	555	
Electrical characteristics (60 Hz)			208/230V-1ph-60Hz						

¹ Annual Fuel Utilization Efficiency based on U.S. DOE test procedures and FTC labeling regulations.

² Sound Rating Number rated in accordance with test conditions included in AHRI Standard 270.

SPECIFICATIONS — LRP14 AC Model

General Data		Model No.	LRP14AC -24	LRP14AC -30	LRP14AC -36	LRP14AC -42	LRP14AC -48	LRP14AC -60	
Nominal Tonnage			2	2.5	3	3.5	4	5	
Cooling Performance	Total Cooling Capacity - Btuh		22,600	28,400	34,000	40,000	46,000	57,000	
	Total unit watts		---	---	---	---	---	---	
	¹ SEER (Btuh/Watt)		14.0	14.0	14.0	14.0	14.0	14.0	
	EER (Btuh/Watt)		11.5	11.5	12.0	11.5	11.5	12.0	
	² Sound Rating Number (dB)		78	78	78	78	78	78	
Refrigerant	Type		HFC-410A	HFC-410A	HFC-410A	HFC-410A	HFC-410A	HFC-410A	
	Charge		4 lbs. 6 oz.	4 lbs. 13 oz.	4 lbs. 15 oz.	6 lbs. 12 oz.	6 lbs. 10 oz.	7 lbs. 13 oz.	
Condensate drain size (fpt) - in.			3/4	3/4	3/4	3/4	3/4	3/4	
Outdoor Coil Fan	Diameter - in. & No. of blades		22 - 4	22 - 4	22 - 4	24 - 3	24 - 3	24 - 3	
	Motor horsepower		1/6	1/6	1/6	1/4	1/4	1/4	
Indoor Blower	Blower wheel size dia. x width - in.		10 x 6	10 x 6	10 x 8	10 x 10	10 x 10	12 x 9	
	Motor horsepower		1/4	1/4	1/3	1/3	1/2	1	
Net weight of basic unit - lbs.			331	343	351	424	428	467	
Shipping weight of basic unit (1 Pkg.)			394	406	414	497	501	540	
Electrical characteristics (60 Hz)			208/230V-1ph-60Hz						

¹ Annual Fuel Utilization Efficiency based on U.S. DOE test procedures and FTC labeling regulations.

² Sound Rating Number rated in accordance with test conditions included in AHRI Standard 270.

SPECIFICATIONS — LRP14 GE Model

General Data	Model No.	LRP14GE -24	LRP14GE -30	LRP14GE -36	LRP14GE -42	LRP14GE -48	LRP14GE -60
	Nominal Tonnage	2	2.5	3	3.5	4	5
Gas Heat Available		-054(X), -072	-054(X), -072	-054, -072(X), -090	-072(X), -090	-108(X), -126	-108(X), -126
Cooling Performance	Total Cooling Capacity - Btuh	22,600	28,400	34,000	40,000	46,000	57,000
	Total unit watts	2055	2580	3090	3635	4180	5180
	¹ SEER (Btuh/Watt)	14.0	14.0	14.0	14.0	14.0	14.0
	EER (Btuh/Watt)	11.0	11.0	11.0	11.0	11.0	11.0
	² Sound Rating Number (dB)	78	78	78	78	78	78
Refrigerant	Type	HFC-410A	HFC-410A	HFC-410A	HFC-410A	HFC-410A	HFC-410A
	Charge	4 lbs. 6 oz.	4 lbs. 13 oz.	4 lbs. 15 oz.	6 lbs. 12 oz.	6 lbs. 10 oz.	7 lbs. 13 oz.
Condensate drain size (fpt) - in.		3/4	3/4	3/4	3/4	3/4	3/4
Outdoor Coil	Net face area - sq. ft.	14.6	16.4	16.4	19.5	19.5	16.6
	Tube dia. - in. & No. of rows	5/16 - 1	5/16 - 1	5/16 - 1	5/16 - 1	5/16 - 1	5/16 - 2
	Fins per inch	26	26	26	26	26	22
Outdoor Coil Fan	Diameter - in. & No. of blades	22 - 4	22 - 4	22 - 4	24 - 3	24 - 3	24 - 3
	Motor horsepower	1/6	1/6	1/6	1/4	1/4	1/4
Indoor Coil	Net face area - sq. ft.	4.4	4.4	4.4	6.8	6.8	6.8
	Tube dia. - in. & No. of rows	3/8 - 2	3/8 - 2	3/8 - 3	3/8 - 3	3/8 - 3	3/8 - 3
	Fins per inch	16	16	15	15	15	15
Indoor Blower	Blower wheel size dia. x width - in.	10 x 6	10 x 6	10 x 8	10 x 10	10 x 10	12 x 9
	Motor horsepower	1/4	1/4	1/3	1/3	1/2	1
Net weight of basic unit - lbs.		358	370	389	460	476	513
Shipping weight of basic unit (1 Pkg.)		421	433	452	533	549	586
Electrical characteristics (60 Hz)		208/230V-1ph-60Hz					

¹ Annual Fuel Utilization Efficiency based on U.S. DOE test procedures and FTC labeling regulations.

² Sound Rating Number rated in accordance with test conditions included in AHRI Standard 270.

SPECIFICATIONS — LRP16 GE Model

General Data	Model No.	LRP16GE -24	LRP16GE -36	LRP16GE -48	LRP16GE -60
	Nominal Tonnage	2	3	4	5
Gas Heat Available		-72(X)	-72(X), -90(X)	-108(X)	-126(X)
Cooling Performance	Total Cooling Capacity - Btuh	23,800	35,400	47,500	57,000
	Total unit watts	1900	2950	3960	4750
	¹ SEER (Btuh/Watt)	16.0	16.0	16.0	16.0
	EER (Btuh/Watt)	12.5	12.0	12.0	12.0
	² Sound Rating Number (dB)	74	75	75	74
Refrigerant	Type	HFC-410A	HFC-410A	HFC-410A	HFC-410A
	Charge	5 lbs. 7 oz.	5 lbs. 12 oz.	6 lbs. 10 oz.	9 lbs. 1 oz.
Condensate drain size (fpt) - in.		3/4	3/4	3/4	3/4
Outdoor Coil	Net face area - sq. ft.	14.6	16.4	19.5	19.1
	Tube dia. - in. & No. of rows	5/16 - 1	5/16 - 1	5/16 - 1	5/16 - 2
	Fins per inch	26	26	26	22
Outdoor Coil Fan	Diameter - in. & No. of blades	22 - 3	22 - 3	24 - 3	24 - 3
	Motor horsepower	1/6	1/6	1/4	1/4
Indoor Coil	Net face area - sq. ft.	4.4	4.4	6.8	6.8
	Tube dia. - in. & No. of rows	3/8 - 3	3/8 - 3	3/8 - 3	3/8 - 3
	Fins per inch	15	15	15	15
Indoor Blower	Blower wheel size dia. x width - in.	10 x 6	10 x 8	10 x 10	12 x 9
	Motor horsepower	1/2	1/2	3/4	1
Net weight of basic unit - lbs.		375	384	486	522
Shipping weight of basic unit (1 Pkg.)		445	456	528	595
Electrical characteristics (60 Hz)		208/230V-1ph-60Hz			

¹ Annual Fuel Utilization Efficiency based on U.S. DOE test procedures and FTC labeling regulations.

² Sound Rating Number rated in accordance with test conditions included in AHRI Standard 270.

SPECIFICATIONS — LRP16 HP Model

General Data		Model No.	LRP16HP -24	LRP16HP -36	LRP16HP -48	LRP16HP -60
		Nominal Tonnage	2	3	4	5
		Total unit watts	1910	2910	3910	4950
Cooling Performance	Total Capacity - Btuh		23,000	35,000	47,000	57,000
	1 SEER (Btuh/Watt)		16.0	16.0	16.0	15.5
	EER (Btuh/Watt)		12.0	12.0	12.0	11.5
	2 Sound Rating Number (dB)		71	71	74	74
Heating Performance	High Temp. Heat Total Capacity - Btuh		22,000	34,000	46,000	56,000
	Total unit watts		1791	2770	3740	4440
	COP		3.60	3.60	3.60	3.70
	HSPF (Region IV)		8.20	8.20	8.20	8.20
	Low Temp. Heat Total Capacity - Btuh		11,900	19,700	26,600	37,200
	Total unit watts		1480	2530	3500	4250
	COP		2.36	2.28	2.23	2.57
Refrigerant		Type	HFC-410A	HFC-410A	HFC-410A	HFC-410A
		Charge	5 lbs. 5 oz.	8 lbs. 0 oz.	10 lbs. 8 oz.	10 lbs. 8 oz.
Condensate drain size (fpt) - in.			3/4	3/4	3/4	3/4
Outdoor Coil	Net face area - sq. ft.		16.3	15.5	18.6	18.6
	Tube dia. - in. & No. of rows		5/16 - 1	5/16 - 2	5/16 - 2	5/16 - 2
	Fins per inch		22	22	22	22
Outdoor Coil Fan	Diameter - in. & No. of blades		22 - 3	22 - 3	24 - 3	24 - 3
	Motor horsepower		1/2	1/2	1/2	1/2
Indoor Coil	Net face area - sq. ft.		4.4	4.4	6.8	6.8
	Tube dia. - in. & No. of rows		5/16 - 3	3/8 - 3	3/8 - 3	3/8 - 3
	Fins per inch		15	15	15	15
Indoor Blower	Blower wheel size dia. x width - in.		10 x 6	10 x 8	10 x 10	12 x 9
	Motor horsepower		1/2	1/2	3/4	1
Net weight of basic unit - lbs.			375	410	490	505
Shipping weight of basic unit (1 Pkg.)			438	473	563	578
Electrical characteristics (60 Hz)			208/230V-1ph-60Hz			

¹ AHRI Certified to AHRI Standard 210/240:

Cooling Ratings - 95°F outdoor air temperature and 80°F db/67°F wb entering indoor coil air.

High Temperature Heating Ratings - 47°F db/43°F wb outdoor air temperature and 70°F entering indoor coil air.

Low Temperature Heating Ratings - 17°F db/15°F wb outdoor air temperature and 70°F entering indoor coil air.

² Sound Rating Number rated in accordance with test conditions included in AHRI Standard 270.

ELECTRIC HEAT CAPACITIES – LRP14 HP and AC Models – LRP16 HP

Input Voltage	5 kW			7.5 kW			10 kW			15 kW			20 kW		
	No of Steps	kW input	Btuh Output	No of Steps	kW input	Btuh Output	No of Steps	kW input	Btuh Output	No of Steps	kW input	Btuh Output	No of Steps	kW input	Btuh Output
208	1	3.8	12,800	1	5.6	19,200	1	7.5	25,600	1	11.2	38,200	1	15.0	51,200
220	1	4.2	14,300	1	6.3	21,500	1	8.4	28,700	1	12.6	43,000	1	16.8	57,300
230	1	4.6	15,700	1	6.9	23,500	1	9.2	31,300	1	13.8	47,000	1	18.4	62,700
240	1	5.0	17,100	1	7.5	25,600	1	10.0	34,100	1	15.0	51,200	1	20.0	68,200

GAS HEAT CAPACITIES – LRP14DF Only

Model	24, 30, 36, 42	36, 42	48, 60
	Heating Input	-072	-090
Heating Capacity Btuh	Input	72,000	90,000
	Output	58,400	72,900
¹ AFUE	81%	81%	81%
Temperature Rise - °F	40-70	40-70	45-75
Gas Supply Connection (FPT) - in.	1/2	1/2	1/2
Min. Recommended Gas Supply Pressure	5 in. w.g. Natural Gas, 11 in. w.g. LPG / Propane		

¹ Annual Fuel Utilization Efficiency based on U.S. DOE test procedures and FTC labeling regulations.

GAS HEAT CAPACITIES – LRP14GE Only

Model		24, 30, 36	24, 30	36, 42	36, 42	48, 60	48, 60
Heating Input		-054	-072	-072	-090	-108	-126
Heating Capacity Btuh	Input	54,000	72,000	72,000	90,000	108,000	126,000
	Output	43,800	58,400	58,400	72,900	87,500	102,100
¹ AFUE		81%	81%	81%	81%	81%	81%
Temperature Rise - °F		30-60	40-70	35-65	40-70	40-70	45-75
Gas Supply Connection (FPT) - in.		1/2	1/2	1/2	1/2	1/2	1/2
Min. Recommended Gas Supply Pressure		5 in. w.g. Natural Gas, 11 in. w.g. LPG / Propane					

¹ Annual Fuel Utilization Efficiency based on U.S. DOE test procedures and FTC labeling regulations.

GAS HEAT CAPACITIES – LRP16GE Only

Model		24, 36	36	48	60
Heating Input		-072	-090	-108	-126
Heating Capacity Btuh	First Stage - Input	54,000	67,500	81,000	94,500
		Output	43,500	54,500	65,500
	Second Stage Input	72,000	90,000	108,000	126,000
		Output	58,000	73,000	88,000
¹ AFUE		81%	81%	81%	81%
Temperature Rise - °F	First Stage	35-45	35-45	45-55	45-55
	Second Stage	45-55	45-55	50-60	50-60
Gas Supply Connection (FPT) - in.		1/2	1/2	1/2	1/2
Min. Recommended Gas Supply Pressure		5 in. w.g. Natural Gas, 11 in. w.g. LPG / Propane			

¹ Annual Fuel Utilization Efficiency based on U.S. DOE test procedures and FTC labeling regulations.

ELECTRICAL/ELECTRIC HEAT DATA — LRP14HP Only

Line voltage data - 60hz - 1 phase		LRP14HP24		LRP14HP30		LRP14HP36		
		208/230V		208/230V		208/230V		
Compressor	Rated Load Amps	10.9		13.5		15.4		
	Locked Rotor Amps	59.3		72.5		83.9		
Outdoor Fan Motor	Full Load Amps	1.0		1.0		1.0		
	Locked Rotor Amps	1.9		1.9		1.9		
Indoor Blower Motor	Full Load Amps	2.8		2.8		4.1		
	Locked Rotor Amps	3.9		3.9		4.4		
¹ Maximum Overcurrent Protection	Voltage	208V	240V	208V	240V	208V	240V	
	Unit only, no electric heat	25	25	30	30	35	35	
	5 kW	30	30	30	30	30	35	
	7.5 kW	40	45	40	45	40	45	
	10 kW	50	60	50	60	50	60	
	³ 15 kW	Circuit 1	---	---	50	60	50	60
	Circuit 2	---	---	25	30	25	30	
¹ Maximum Overcurrent Protection with Optional Single-Point Power Supply	5 kW	45	45	45	50	50	50	
	7.5 kW	60	60	60	60	60	70	
	10 kW	70	70	70	80	70	80	
	15 kW	---	---	90	100	100	110	
² Minimum Circuit Ampacity	Unit only, no electric heat	17.4	17.4	20.7	20.7	24.4	24.4	
	5 kW	25.4	28.8	25.4	28.8	26.7	30.1	
	7.5 kW	36.7	41.9	36.7	41.9	38	43.2	
	10 kW	47.9	54.9	47.9	54.9	49.2	56.2	
	³ 15 kW	Circuit 1	---	---	47.9	54.9	49.2	56.2
		Circuit 2	---	---	22.6	26	22.6	26
² Minimum Circuit Ampacity with Optional Single-Point Power Supply	5 kW	39.1	42.4	42.3	45.7	46	49.4	
	7.5 kW	50.3	55.6	53.6	58.8	57.2	62.5	
	10 kW	61.6	68.6	64.8	71.8	68.5	75.5	
	15 kW	---	---	87.4	97.8	91.1	101.5	

NOTE - All units have a minimum Short Circuit Current Rating (SCCR) of 5000 amps.

NOTE - Circuit 1 Minimum Circuit Ampacity includes the Blower Motor Full Load Amps.

NOTE - Extremes of operating range are plus and minus 10% of line voltage.

¹ HACR type breaker or fuse.

² Refer to National or Canadian Electrical Code manual to determine wire, fuse and disconnect size requirements.

³ A separate compressor circuit is required.

ELECTRICAL/ELECTRIC HEAT DATA — LRP14HP Only (Contd.)

Model No.		LRP14HP42		LRP14HP48		LRP14HP60		
Line voltage data - 60hz - 1 phase		208/230V		208/230V		208/230V		
Compressor	Rated Load Amps	15.9		18		24.3		
	Locked Rotor Amps	85		117		144.2		
Outdoor Fan Motor	Full Load Amps	1.7		1.7		1.7		
	Locked Rotor Amps	3.2		3.2		3.2		
Indoor Blower Motor	Full Load Amps	2.8		2.8		7.6		
	Locked Rotor Amps	5.4		6.8		---		
¹ Maximum Overcurrent Protection	Voltage	208V	240V	208V	240V	208V	240V	
	Unit only, no electric heat	40	40	45	45	60	60	
	5 kW	30	30	30	30	35	35	
	7.5 kW	40	45	40	45	45	50	
	10 kW	50	60	50	60	60	60	
	³ 15 kW	Circuit 1	50	60	50	60	60	60
		Circuit 2	25	30	25	30	25	30
	³ 20 kW	Circuit 1	50	60	50	60	50	60
		Circuit 2	50	60	50	60	50	60
	¹ Maximum Overcurrent Protection with Optional Single-Point Power Supply	5 kW	50	50	60	60	80	80
7.5 kW		60	70	70	70	80	90	
10 kW		70	80	80	80	90	100	
15 kW		100	110	100	110	110	125	
20 kW		125	150	125	150	150	150	
² Minimum Circuit Ampacity	Unit only, no electric heat	24.4	24.4	27	27	39.7	39.7	
	5 kW	25.4	28.8	25.4	28.8	30.2	33.6	
	7.5 kW	36.7	41.9	36.7	41.9	41.5	46.7	
	10 kW	47.9	54.9	47.9	54.9	52.7	59.7	
	³ 15 kW	Circuit 1	47.9	54.9	47.9	54.9	52.7	59.7
		Circuit 2	22.6	26	22.6	26	22.6	26
	³ 20 kW	Circuit 1	47.9	54.9	47.9	54.9	52.7	59.7
		Circuit 2	45.1	52.1	45.1	52.1	45.1	52.1
² Minimum Circuit Ampacity with Optional Single-Point Power Supply	5 kW	45.3	48.7	47.9	51.3	60.6	64	
	7.5 kW	56.6	61.8	59.2	64.4	71.9	77.1	
	10 kW	67.8	74.8	70.4	77.4	83.1	90.1	
	15 kW	90.4	100.8	93.1	103.4	105.7	116.1	
	20 kW	112.9	126.8	115.6	129.4	128.2	142.1	

NOTE - All units have a minimum Short Circuit Current Rating (SCCR) of 5000 amps.

NOTE - Circuit 1 Minimum Circuit Ampacity includes the Blower Motor Full Load Amps.

NOTE - Extremes of operating range are plus and minus 10% of line voltage.

¹ HACR type breaker or fuse.

² Refer to National or Canadian Electrical Code manual to determine wire, fuse and disconnect size requirements.

³ A separate compressor circuit is required.

ELECTRICAL DATA — LRP14DF Only

Model No.		LRP14DF24	LRP14DF30	LRP14DF36	LRP14DF42	LRP14DF48	LRP14DF60
Line voltage data - 60hz - 1 phase		208/230V		208/230V		208/230V	
¹ Maximum Overcurrent Protection (amps)		25	30	35	40	45	60
² Minimum Circuit Ampacity		17.4	20.7	24.4	24.4	27	39.7
Compressor	Rated Load Amps	10.9	13.5	15.4	15.9	18	24.3
	Locked Rotor Amps	59.3	72.5	83.9	85	117	144.2
Outdoor Coil Fan Motor	Full Load Amps	1.0	1.0	1.0	1.7	1.7	1.7
	Locked Rotor Amps	1.9	1.9	1.9	3.2	3.2	3.2
Indoor Blower Motor	Full Load Amps	2.8	2.8	4.1	2.8	2.8	7.6
	Locked Rotor Amps	---	---	---	5.4	6.8	---

NOTE - All units have a minimum Short Circuit Current Rating (SCCR) of 5000 amps.

NOTE - Extremes of operating range are plus and minus 10% of line voltage.

¹ HACR type breaker or fuse.

² Refer to National or Canadian Electrical Code manual to determine wire, fuse and disconnect size requirements.

ELECTRICAL/ELECTRIC HEAT DATA — LRP14AC Only

Line voltage data - 60Hz - 1 phase		LRP14AC24		LRP14AC30		LRP14AC36		
		208/230V		208/230V		208/230V		
Compressor	Rated Load Amps	10.9		13.5		15.4		
	Locked Rotor Amps	59.3		72.5		83.9		
Outdoor Fan Motor	Full Load Amps	1.0		1.0		1.0		
	Locked Rotor Amps	1.9		1.9		1.9		
Indoor Blower Motor	Rated Load Amps	2.8		2.8		4.1		
	Locked Rotor Amps	3.9		3.9		4.4		
¹ Maximum Overcurrent Protection	Voltage	208V	240V	208V	240V	208V	240V	
	Unit only, no electric heat	25	25	30	30	30	30	
	5 kW	25	30	25	30	25	30	
	7.5 kW	40	45	40	45	40	45	
	10 kW	50	60	50	60	50	60	
	³ 15 kW	Circuit 1	---	---	50	60	50	60
	Circuit 2	---	---	25	30	25	30	
¹ Maximum Overcurrent Protection with Optional Single-Point Power Supply	5 kW	25	30	30	30	30	30	
	7.5 kW	40	45	40	45	40	45	
	10 kW	50	60	50	60	50	60	
	15 kW	---	---	70	80	70	90	
² Minimum Circuit Ampacity	Unit only, no electric heat	16.7	16.7	18.7	18.7	20.6	20.6	
	5 kW	24.3	27.7	24.3	27.7	24.6	28	
	7.5 kW	35.6	40.8	35.6	40.8	35.9	41.1	
	10 kW	46.8	53.8	46.8	53.8	47.1	54.1	
	³ 15 kW	Circuit 1	---	---	46.8	53.8	47.1	54.1
		Circuit 2	---	---	22.6	26	22.6	26
² Minimum Circuit Ampacity with Optional Single-Point Power Supply	5 kW	24.3	27.7	24.3	27.7	24.6	28	
	7.5 kW	35.6	40.8	35.6	40.8	35.9	41.1	
	10 kW	46.8	53.8	46.8	53.8	47.1	54.1	
	15 kW	---	---	69.4	79.8	69.7	80.1	

NOTE - All units have a minimum Short Circuit Current Rating (SCCR) of 5000 amps.

NOTE - Circuit 1 Minimum Circuit Ampacity includes the Blower Motor Full Load Amps.

NOTE - Extremes of operating range are plus and minus 10% of line voltage.

¹ HACR type breaker or fuse.

² Refer to National or Canadian Electrical Code manual to determine wire, fuse and disconnect size requirements.

³ A separate compressor circuit is required.

ELECTRICAL/ELECTRIC HEAT DATA — LRP14AC Only (Contd.)

Model No.		LRP14AC42		LRP14AC48		LRP14AC60		
Line voltage data - 60Hz - 1 phase		208/230V		208/230V		208/230V		
Compressor	Rated Load Amps	15.9		18		24.3		
	Locked Rotor Amps	85		117		144.2		
Outdoor Fan Motor	Full Load Amps	1.7		1.7		1.7		
	Locked Rotor Amps	3.2		3.2		3.2		
Indoor Blower Motor	Rated Load Amps	2.8		2.8		7.6		
	Locked Rotor Amps	5.4		6.8		---		
¹ Maximum Overcurrent Protection	Voltage	208V	240V	208V	240V	208V	240V	
	Unit only, no electric heat	40	40	40	40	60	60	
	5 kW	30	30	30	30	35	35	
	7.5 kW	40	45	40	45	45	50	
	10 kW	50	60	50	60	60	60	
	³ 15 kW	Circuit 1	50	60	50	60	60	60
		Circuit 2	25	30	25	30	60	60
	³ 20 kW	Circuit 1	50	60	50	60	60	60
		Circuit 2	50	60	50	60	60	60
	¹ Maximum Overcurrent Protection with Optional Single-Point Power Supply	5 kW	40	40	40	40	60	60
7.5 kW		40	45	40	45	60	60	
10 kW		50	60	50	60	60	60	
15 kW		80	90	80	90	80	90	
20 kW		100	110	100	110	100	125	
² Minimum Circuit Ampacity	Unit only, no electric heat	24.4	24.4	26.9	26.9	38.9	38.9	
	5 kW	25.4	28.8	25.4	28.8	30.2	33.6	
	7.5 kW	36.7	41.9	36.7	41.9	41.5	46.7	
	10 kW	47.9	54.9	47.9	54.9	52.7	59.7	
	³ 15 kW	Circuit 1	47.9	54.9	47.9	54.9	52.7	59.7
		Circuit 2	22.6	26	22.6	26	22.6	26
	³ 20 kW	Circuit 1	47.9	54.9	47.9	54.9	52.7	59.7
		Circuit 2	45.1	52.1	45.1	52.1	45.1	52.1
² Minimum Circuit Ampacity with Optional Single-Point Power Supply	5 kW	25.4	28.8	26.9	28.8	38.9	38.9	
	7.5 kW	36.7	41.9	36.7	41.9	41.5	46.7	
	10 kW	47.9	54.9	47.9	54.9	52.7	59.7	
	15 kW	70.5	80.9	70.5	80.9	75.3	85.7	
	20 kW	93	107	93	107	97.8	111.8	

NOTE - All units have a minimum Short Circuit Current Rating (SCCR) of 5000 amps.

NOTE - Circuit 1 Minimum Circuit Ampacity includes the Blower Motor Full Load Amps.

NOTE - Extremes of operating range are plus and minus 10% of line voltage.

¹ HACR type breaker or fuse.

² Refer to National or Canadian Electrical Code manual to determine wire, fuse and disconnect size requirements.

³ A separate compressor circuit is required.

ELECTRICAL DATA — LRP14GE Only

Model No.		LRP14GE24	LRP14GE30	LRP14GE36	LRP14GE42	LRP14GE48	LRP14GE60
Line voltage data - 60hz - 1 phase		208/230V		208/230V		208/230V	
¹ Maximum Overcurrent Protection (amps)		25	30	30	40	40	60
² Minimum Circuit Ampacity		16.7	18.7	20.6	24.4	26.9	38.9
Compressor	Rated Load Amps	11.2	12.8	14.1	15.9	17.9	23.7
	Locked Rotor Amps	60.8	64	72.2	85	96	152.5
Outdoor Coil Fan Motor	Full Load Amps	1.0	1.0	1.0	1.7	1.7	1.7
	Locked Rotor Amps	1.9	1.9	1.9	3.2	3.2	3.2
Indoor Blower Motor	Full Load Amps	1.7	1.7	2.0	2.8	2.8	7.6
	Locked Rotor Amps	3.9	3.9	4.4	5.4	6.8	---

NOTE - All units have a minimum Short Circuit Current Rating (SCCR) of 5000 amps.

NOTE - Extremes of operating range are plus and minus 10% of line voltage.

¹ HACR type breaker or fuse.

² Refer to National or Canadian Electrical Code manual to determine wire, fuse and disconnect size requirements.

ELECTRICAL DATA — LRP16GE Only

Model No.		LRP16GE24	LRP16GE36	LRP16GE48	LRP16GE60
Line voltage data - 60hz - 1 phase		208/230V			
¹ Maximum Overcurrent Protection (amps)		25	35	50	60
² Minimum Circuit Ampacity		17.0	22.7	31.2	41.7
Compressor	Rated Load Amps	11.7	15.3	21.2	28.8
	Locked Rotor Amps	58.3	83.0	104.0	152.9
Outdoor Coil Fan Motor	Full Load Amps	1.0	1.0	1.7	1.7
	Locked Rotor Amps	1.9	1.9	3.2	3.2
Indoor Blower Motor	Full Load Amps	1.1	2.3	3.1	4.0
	Locked Rotor Amps	4.3	4.3	6.8	9.1

NOTE - All units have a minimum Short Circuit Current Rating (SCCR) of 5000 amps.

NOTE - Extremes of operating range are plus and minus 10% of line voltage.

¹ HACR type breaker or fuse.

² Refer to National or Canadian Electrical Code manual to determine wire, fuse and disconnect size requirements.

ELECTRICAL/ELECTRIC HEAT DATA — LRP16HP Only

Model No.		LRP16HP24		LRP16HP36		LRP16HP48		LRP16HP60		
Line voltage data - 60hz - 1 phase		208/230V		208/230V		208/230V		208/230V		
Compressor	Rated Load Amps	11.7		16.1		21.2		27.1		
	Locked Rotor Amps	58.3		83.0		104.0		152.9		
Outdoor Fan Motor	Full Load Amps	1.2		1.4		2.3		2.4		
Indoor Blower Motor	Full Load Amps	1.7		3.6		4.5		5.5		
¹ Maximum Overcurrent Protection	Voltage	208V	240V	208V	240V	208V	240V	208V	240V	
	Unit only, no electric heat	25	25	40	40	50	50	60	60	
	5 kW	25	30	30	35	30	35	35	35	
	7.5 kW	40	45	40	45	40	45	45	50	
	10 kW	50	60	50	60	60	60	60	60	
	³ 15 kW	Circuit 1	---	---	50	60	60	60	60	60
		Circuit 2	---	---	25	30	25	30	25	30
	³ 20 kW	Circuit 1	---	---	---	---	60	60	60	60
		Circuit 2	---	---	---	---	50	60	50	60
	¹ Maximum Overcurrent Protection with Optional Single-Point Power Supply	5 kW	45	50	50	60	70	70	80	90
7.5 kW		60	60	60	70	80	80	90	100	
10 kW		70	80	80	80	90	90	100	110	
15 kW		---	---	100	110	110	125	110	125	
20 kW		---	---	---	---	125	150	150	150	
² Minimum Circuit Ampacity	Unit only, no electric heat	18.0	18.0	25.6	25.6	33.8	33.8	42.3	42.3	
	5 kW	24.7	28.2	27.1	30.5	28.2	31.7	29.5	32.9	
	7.5 kW	36.0	41.2	38.3	43.6	39.5	44.7	40.7	45.9	
	10 kW	47.3	54.2	49.6	56.6	50.8	57.7	52.0	59.0	
	³ 15 kW	Circuit 1	---	---	49.6	56.6	50.8	57.7	52.0	59.0
		Circuit 2	---	---	22.6	26.0	22.6	26.0	22.6	26.0
	³ 20 kW	Circuit 1	---	---	---	---	50.8	57.7	52.0	59.0
		Circuit 2	---	---	---	---	45.1	52.1	45.1	52.1
² Minimum Circuit Ampacity with Optional Single-Point Power Supply	5 kW	40.6	44.0	48.2	51.6	56.4	59.8	64.9	68.3	
	7.5 kW	51.8	57.1	59.4	64.7	67.6	72.8	76.1	81.3	
	10 kW	63.1	70.1	70.7	77.7	78.9	85.9	87.4	94.3	
	15 kW	---	---	93.3	103.7	101.5	111.9	110.0	120.4	
	20 kW	---	---	---	---	124.1	137.9	132.5	146.4	

NOTE - All units have a minimum Short Circuit Current Rating (SCCR) of 5000 amps.

NOTE - Circuit 1 Minimum Circuit Ampacity includes the Blower Motor Full Load Amps.

NOTE - Extremes of operating range are plus and minus 10% of line voltage.

¹ HACR type breaker or fuse.

² Refer to National or Canadian Electrical Code manual to determine wire, fuse and disconnect size requirements.

³ A separate compressor circuit is required.

HIGH ALTITUDE DERATE

Units may be installed at altitudes up to 4500 feet (1372 m) above sea level without any modification. At altitudes above 4500 feet (1372 m), units must be derated as shown in table 1.

NOTE - This is the only permissible derate for these units.

Table 1. Manifold Pressure Versus Altitude

Natural Gas				Propane (LP)		
Altitude (ft.)	Heating value* (BTU/ft)	Manifold Pressure (in. w. c.)		Heating value* (BTU/ft)	Manifold Pressure (in. w. c.)	
		High	Low		High	Low
2000	948	3.50	2.00	2278	10.00	5.60
3000	914	3.50	2.00	2196	10.00	5.60
4000	881	3.50	2.00	2116	10.00	5.60
4500	865	3.50	2.00	2077	10.00	5.60
5000	849	3.29	1.88	2039	9.41	5.38
5500	833	3.27	1.87	2000	9.35	5.34
6000	818	3.25	1.86	1964	9.29	5.31
6500	802	3.23	1.84	1927	9.24	5.28
7000	787	3.21	1.83	1891	9.18	5.25
7500	771	3.19	1.82	1853	9.12	5.21

* Consult local utility for actual heating value.
 Furnace input = Input Factor X Nameplate Input
 Above 7500 feet, call Lennox Technical Services for additional assistance.

TYPICAL PARTS ARRANGEMENT

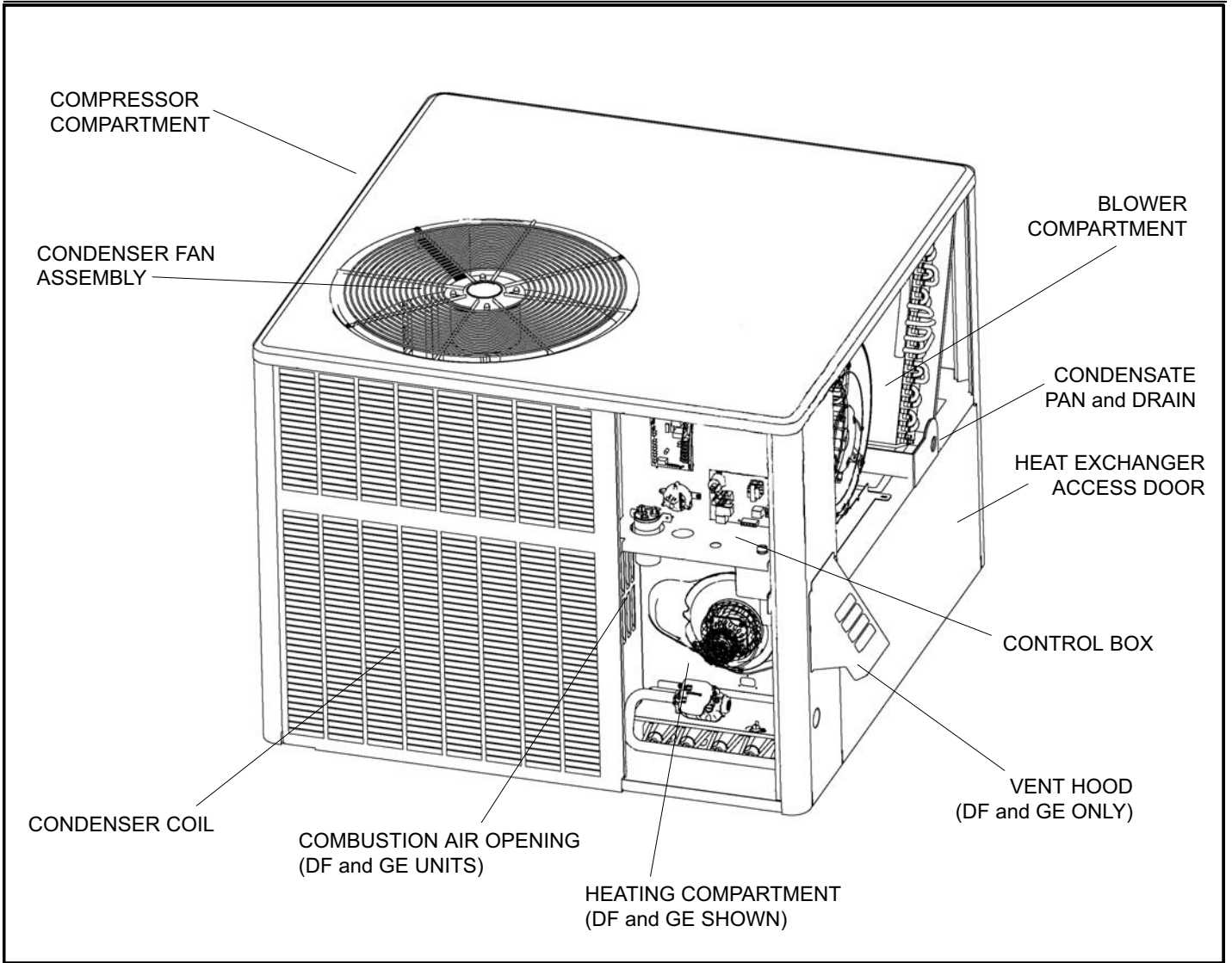

FIGURE 1. Typical Parts Arrangement (LRP14DF and LRP14GE shown)

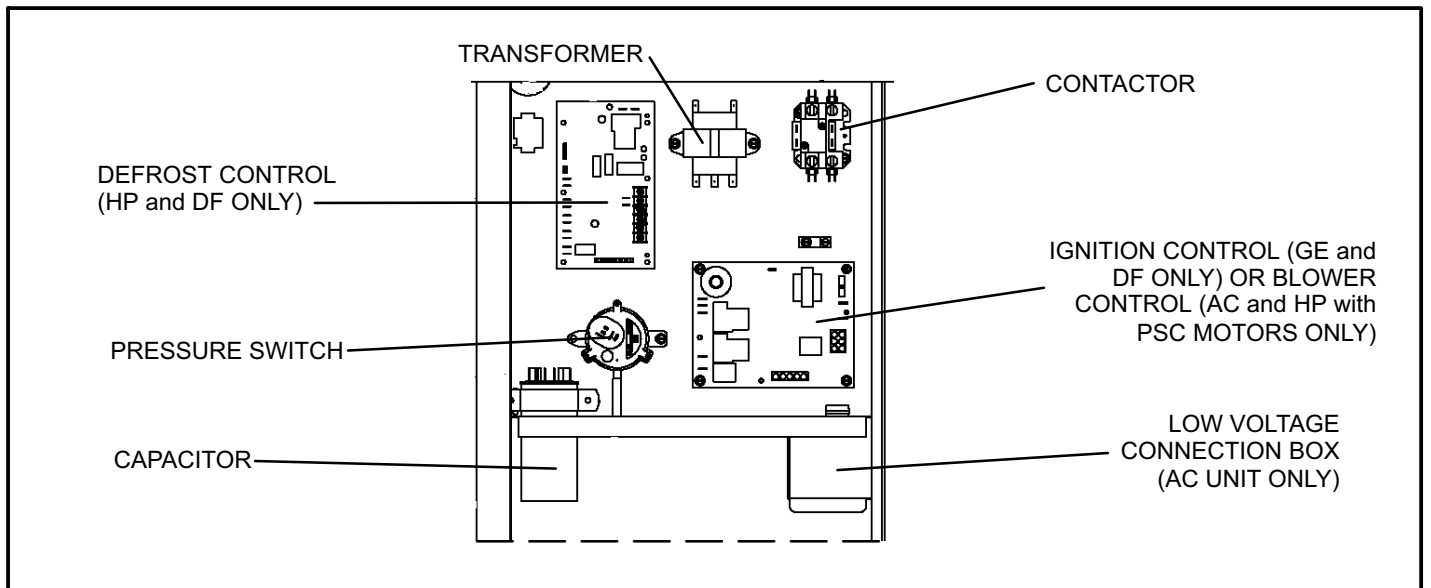

FIGURE 2. Typical Control Box

PARTS ARRANGEMENT — Contd.

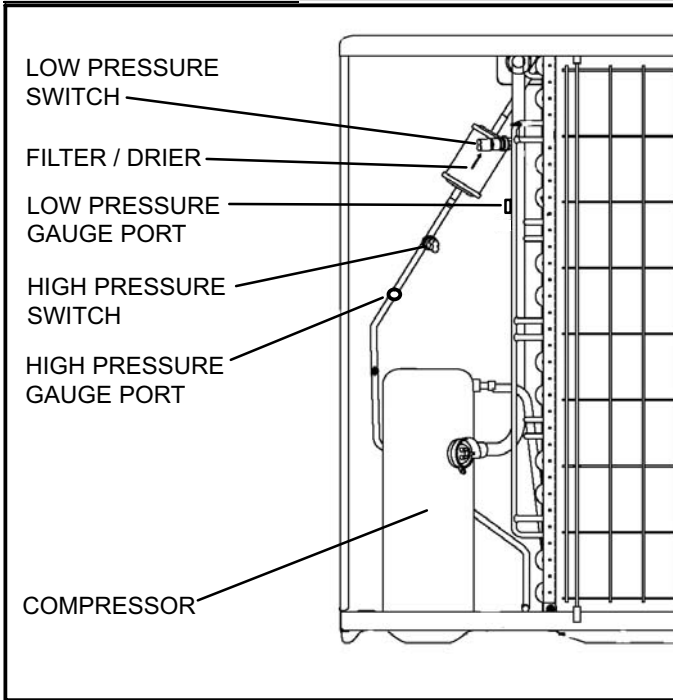

FIGURE 3. Compressor Compartment — AC and GE units

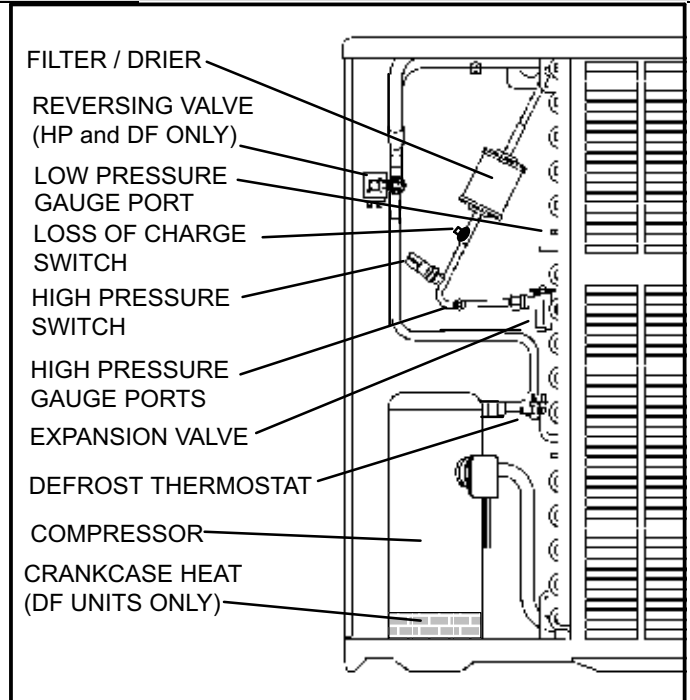

FIGURE 5. Compressor Compartment — (-2 build) HP and DF units

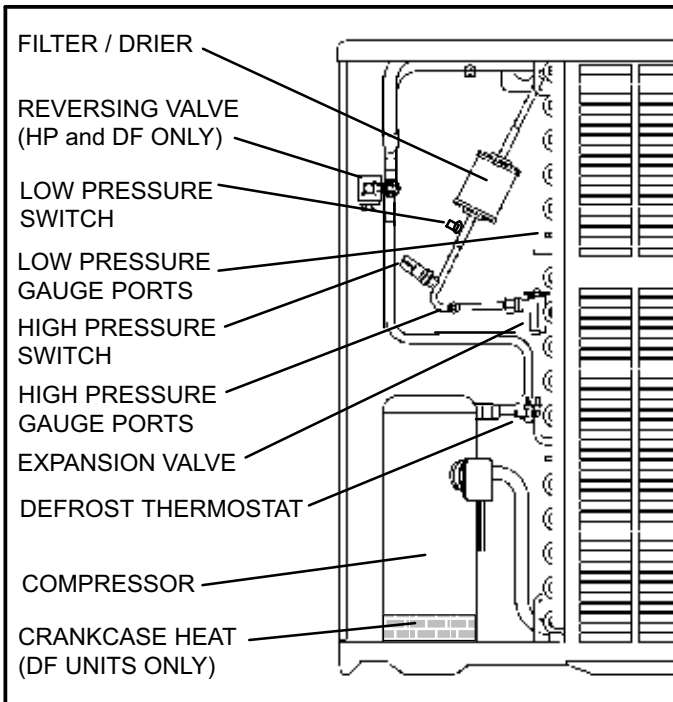

FIGURE 4. Compressor Compartment — HP and DF units

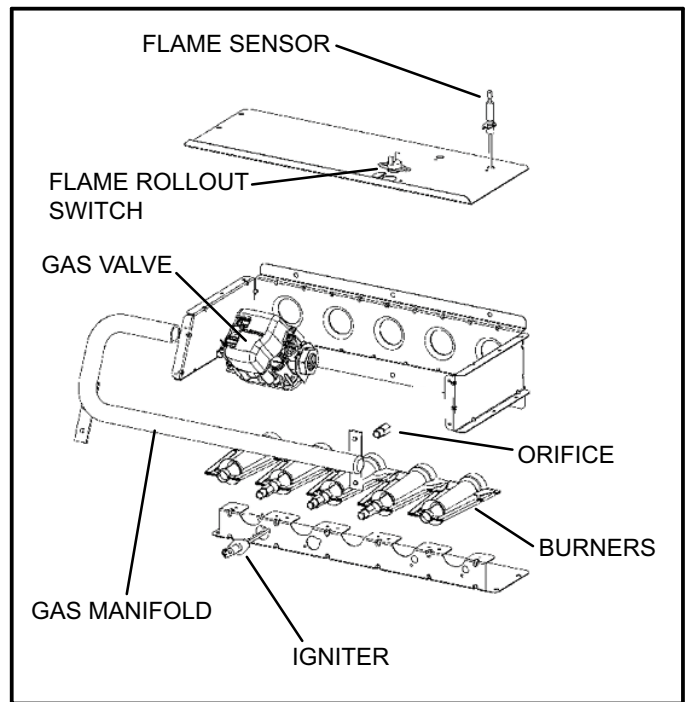

FIGURE 6. Burner Box Components — DF and GE units

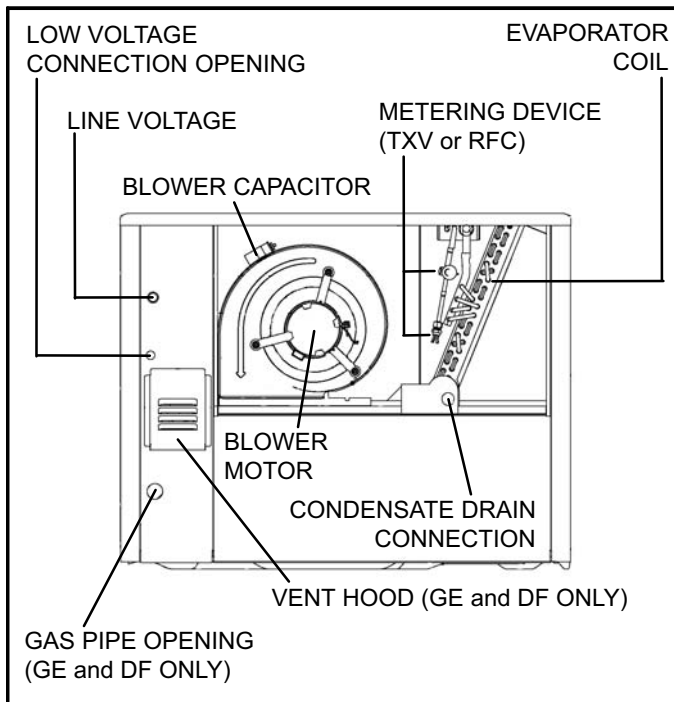

FIGURE 7. Blower Compartment

UNIT APPLICATIONS

LRP14HP

LRP14HP, 2 through 5 ton (7.0 through 17.6kW) model units, are single phase packaged heat pump units designed for outdoor installation on a slab or rooftop in residential applications. The units are available in two cabinet sizes. Optional electric heat must be field installed if required. Units are available with constant torque or PSC blower motors.

In heating mode, the unit operates the heat pump for 1st stage heating. If 1st stage is not satisfied, the 2nd stage activates electric heat sections (secondary heat source). Refer to Product Specifications (EHB) for auxiliary heat selections.

All heat pump units are equipped with single-stage cooling only.

LRP14DF

LRP14DF, 2 through 5 ton (7.0 through 17.6kW) model units, are single phase packaged dual fuel heat pump units designed for outdoor installation on a slab or rooftop in residential applications. The units are available in two cabinet sizes. Gas-fueled supplemental heat is factory installed for use in dual fuel units. Refer to page 4 for gas heat capacities. Units are available with constant torque or PSC blower motors.

In heating mode, the heat pump is used to satisfy 1st stage heating demand. If more heat is needed, W1 will activate gas heating to satisfy the heating call.

All dual fuel units are equipped with single-stage cooling only.

LRP14AC

LRP14AC, 2 through 5 ton (7.0 through 17.6kW) model units, are single phase packaged air conditioning units designed for outdoor installation on a slab or rooftop in residential applications. The units are available in two cabinet sizes. Optional electric heat must be field installed if required. Refer to Product Specifications (EHB) for electric heat options. Units are available with constant torque or PSC blower motors. All LRP14AC units are equipped with single-stage cooling only.

LRP14GE

LRP14GE, 2 through 5 ton (7.0 through 17.6kW) model units, are single phase packaged air conditioning units designed for outdoor installation on a slab or rooftop in residential applications. The units are available in two cabinet sizes.

A gas heat component is factory installed. Units are available with constant torque or PSC blower motors. All LRP14GE units are equipped with single-stage cooling and gas heat.

LRP16HP

LRP16HP, 2 through 5 ton (7.0 through 17.6kW) model units, are single phase packaged heat pump units designed for outdoor installation on a slab or rooftop in residential applications. The units are available in two cabinet sizes. Optional electric heat must be field installed if required. Units are equipped with variable-speed ECM blower motors. All LRP16HP units are equipped with a two-stage Copeland compressor providing two-stage cooling.

In heating mode, the unit operates the heat pump for 1st stage heating. If 1st stage is not satisfied, the 2nd stage activates electric heat sections (secondary heat source). Refer to Product Specifications (EHB) for auxiliary heat selections.

LRP16GE

LRP16GE, 2 through 5 ton (7.0 through 17.6kW) model units, are single phase packaged air conditioning units designed for outdoor installation on a slab or rooftop in residential applications. The units are available in two cabinet sizes.

A gas heat component is factory installed. Units are equipped with variable-speed ECM blower motors. All LRP16GE units are equipped with a two-stage Copeland compressor providing two-stage cooling and gas heat.

UNIT COMPONENTS / OPERATION

Unit components are shown in figure 1.

Control Box Components

Control box components are shown in figure 2.

Compressor Contactor K1

K1 is a 24VAC to line voltage single-pole contactor, which energizes the compressor and condenser fan in response to thermostat demand.

Control Transformer T1

All LRP14 series units use line voltage to 24VAC transformer mounted in the control box. The transformer supplies power to control circuits in the unit. Transformers use two primary voltage taps as shown in figure 8.

NOTE - The unit is factory-shipped at 230/240 volts.

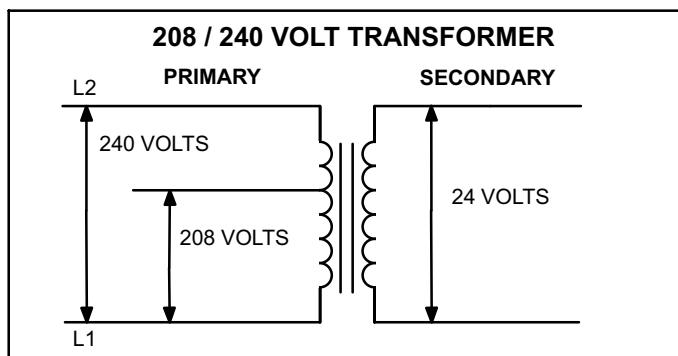

FIGURE 8

Dual Capacitor C12

The compressor and condenser fan in the LRP14/16 series units use permanent split capacitor motors. The capacitor is located in the control box. A dual rated capacitor is used for both the condenser fan motor and the compressor (see unit wiring diagram per respective unit). The fan side and the compressor side of the capacitor have different MFD ratings. See repair parts or nameplate for correct capacitor.

Ignition Control (A3)

⚠ WARNING

Shock hazard.

Disconnect power before servicing. Control is not field repairable. If control is inoperable, simply replace entire control.

Can cause injury or death. Unsafe operation will result if repair is attempted.

The LRP14DF and LRP14/16GE units include an ignition control which controls the combustion air inducer, gas valve and spark electrode. It receives signals from the limit switch, the rollout switch, the pressure prove switch and the flame sensor. The ignition control is shown in figure 9. LED codes are in table 1.

Electronic Ignition

On a W1 call the ignition control checks high temperature limit and rollout switch to make sure they are closed. The control then verifies that the pressure switch is open. If the pressure switch is closed, the control will flash code 3 on the LED and will wait indefinitely for the pressure switch to

open. If the pressure switch is open, the control proceeds to the 15-second pre-purge.

The ignition control energizes the combustion air inducer, flashes a code 3 on the LED, and waits for the pressure switch to close.

When the pressure switch has closed, the LED code 3 flash stops and the control begins the 15-second pre-purge period. When the pre-purge time has expired, the control begins the ignition trial.

The ignition control energizes the gas valve and spark. The control ignores the flame sense signal for the first two seconds of the ignition trial. If the flame is established within 10 seconds, the control de-energizes the spark. If flame is not established within 10 seconds, the gas valve and spark are de-energized and the ignition control initiates a 30-second inter-purge sequence.

Approximately 30 seconds after the flame has been established, the circulating air blower starts. The ignition control inputs are continuously monitored to ensure that the limit switch, rollout switch and pressure switch are all closed, and that the flame remains established and heating demand is present. Single-stage gas valve, single-speed combustion air inducer and circulating blower remain energized. If the thermostat signals a requirement for second-stage heat (W2) on the dual fuel unit, the ignition control initiates auxiliary or back-up heat operation.

When a signal for second-stage heat is received by the ignition control, the control energizes the gas valves on dual fuel units and single-speed combustion air inducer until the demand is satisfied.

If a first-stage heat demand continues after the second-stage heat demand has been satisfied, the ignition control immediately de-energizes the gas valve. Heat pump operation continues until heating demand is satisfied.

When the heating demand is satisfied for dual fuel first stage, the control immediately de-energizes the compressor. The combustion air inducer remains energized for a 30-second post-purge period. The circulating air blower operates for 90 seconds after the gas valve is de-energized (GE units only).

The combustion air inducer is energized for 30 seconds at a Y1 call for cooling to clear warm humid air out of the heat exchanger.

The ignition control LED flashes codes which indicate normal or abnormal operations. See table 1.

IGNITION CONTROL (A3)

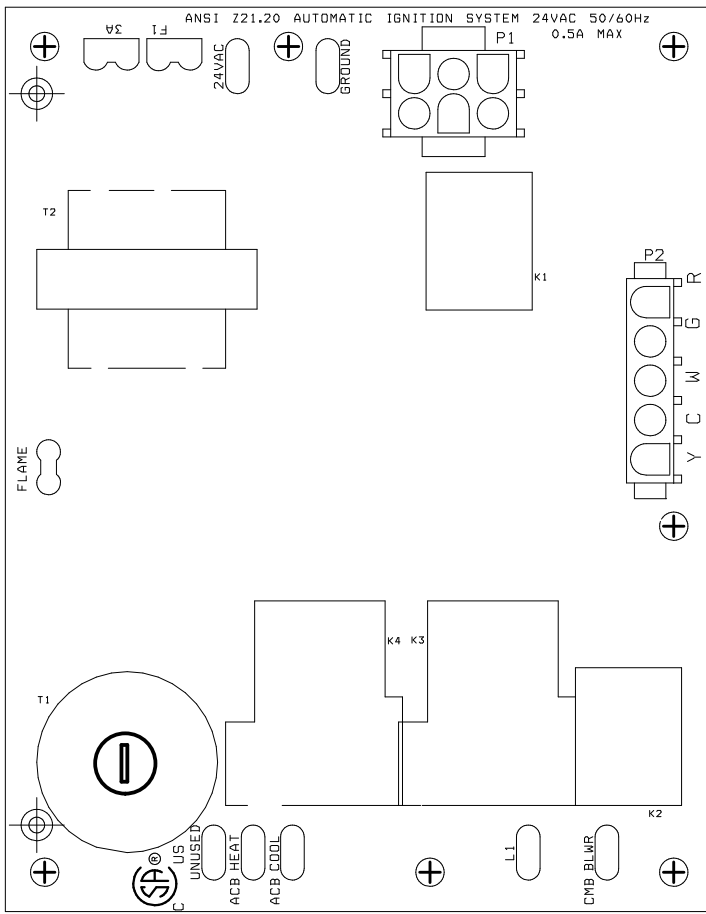

QUICK CONNECT CONNECTIONS:

.25 MALE QUICK CONNECTS:

- T1 - SPARK MODULE
- 24 VAC HOT
- GROUND = 24 VAC RETURN
- CMB BLOWER = COMBUSTION BLOWER (LINE VOLTAGE)
- LI = LINE VOLTAGE
- ACB COOL = AIR CIRCULATING BLOWER COOL SPEED (LINE VOLTAGE)
- ACB HEAT = AIR CIRCULATING BLOWER HEAT SPEED (LINE VOLTAGE)
- UNUSED

.19 MALE QUICK CONNECT:

- FLAME = FLAME PROBE

MOLEX/AMP PLUG-IN DESCRIPTION:

1. ROLLOUT SWITCH RETURN
2. HI LIMIT RETURN/PRESSURE SWITCH OUT
3. GAS VALVE COMMON
4. GAS VALVE OUT
5. PRESSURE SWITCH RETURN
6. ROLLOUT SWITCH OUT

THERMOSTAT INPUT:

- R = 24 VAC TO THERMOSTAT (RED)
- G = MANUAL FAN INPUT FROM THERMOSTAT (GREEN)
- W = HEAT DEMAND INPUT FROM THERMOSTAT (WHITE)
- C = COMMON GROUND TO THERMOSTAT
- Y = COOL DEMAND INPUT FROM THERMOSTAT (YELLOW)

HEAT MODE:

- PREPURGE: 30 SEC.
- INTER-PURGE: 30 SEC.
- POST PURGE: 5 SEC.
- TRIAL TIME: 10 SEC.
- # TRIAL: 3
- BOARD TO RESET FROM LOCKOUT AFTER 60 MIN.

FAN ON DELAY:

- COOL: 5 SEC. (FIXED)
- HEAT: 30 SEC. (FIXED)

FAN OFF DELAY:

- COOL: 90 SEC. (FIXED)
- HEAT: 120 SEC. (FIXED)

FIGURE 9. Ignition Control – Gas-Heat Units Only

TABLE 1. LED Diagnostic Codes — Ignition Control

Slow Flash - 1 per second	Normal operation, no call for heat
Fast Flash - 2 per second	Normal operation, call for heat
Steady Off	Internal failure or no power
Steady On	Internal control failure
Code 2 - 2 flashes in 1 sec with 1 sec pause	Lockout, failed to detect or sustain flame, gas valve knob or switch off.
Code 3 - 3 flashes in 1 1/2 sec with 1 sec pause	Pressure switch open or closed

Code 4 - 4 flashes in 2 sec with 1 sec pause	High temp limit or rollout switch open
Code 5 - 5 flashes in 2 1/2 sec with 1 sec pause	Flame sensed with gas valve de-energized

! WARNING

Electric shock hazard. Can cause injury or death. Before attempting to perform any service or maintenance, turn the electrical power to unit OFF at disconnect switch(es). Unit may have multiple power supplies.

BLOWER CONTROL (A15) – LRP14 UNITS

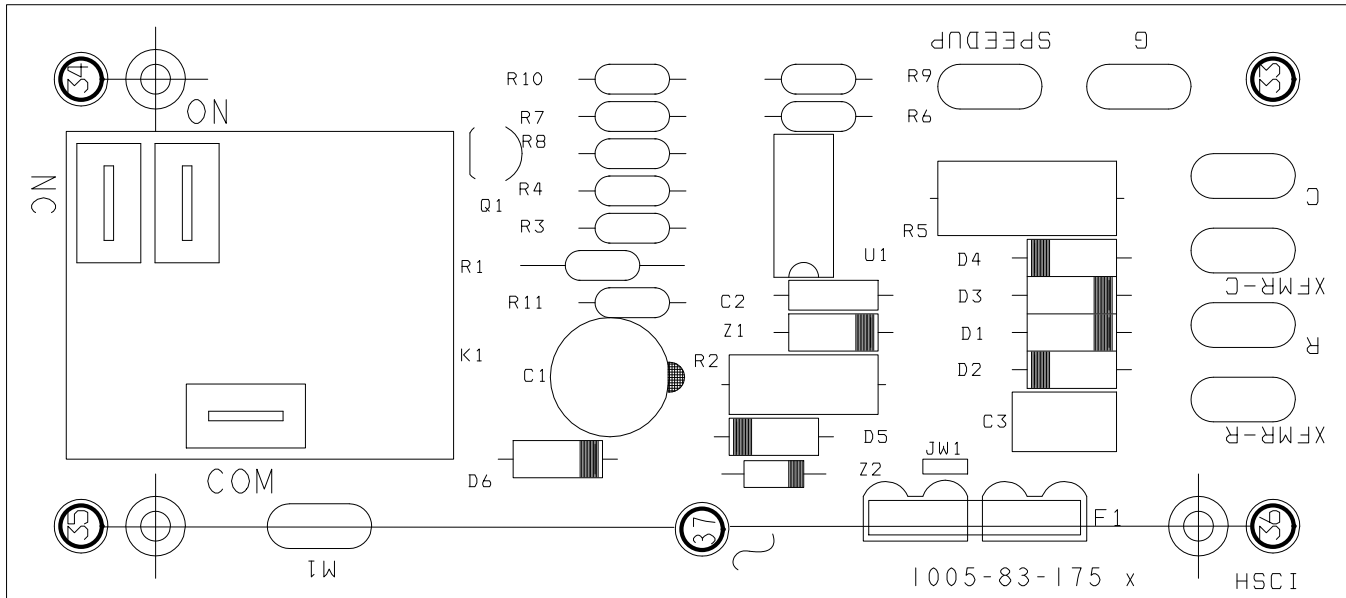

NOTES:

1. INPUT VOLTAGE: 18 TO 30 VAC
2. INPUT CURRENT: 100 mA. MAX. @ 24 VAC
3. THE DELAY BLOWER CONTROL PROVIDES POWER TO THE BLOWER MOTOR WITH A DELAY OF 0 SECONDS AFTER 24VAC IS APPLIED TO "G". AFTER 24VAC IS REMOVED FROM "G", THE BLOWER MOTOR OUTPUT IS DE-ENERGIZED AFTER A DELAY OF 90 SECONDS.

NORMAL TIME DELAYS:	60Hz	50Hz
TURN ON DELAY	0.0 SEC.±1%	0.0 SEC.±1%
TURN OFF DELAY	90.0 SEC.±1%	108.0 SEC.±1%

4. FIELD TEST MODE: SHORTING THE .250 SPEEDUP QUICK CONNECT TO "C" DECREASE TIMES AS FOLLOWS:

SPEEDUP TIMES	60Hz	50Hz
TURN ON DELAY	0.0 SEC.±1%	0.0 SEC.±1%
TURN OFF DELAY	5.0 SEC.±1%	6.0 SEC.±1%

FIELD TEST MODE IS CANCELLED WHEN THE .250 SPEEDUP QUICK CONNECT TO "C" SHORT IS REMOVED.

FIGURE 10. Blower Control LRP14 – PSC Motor – AC & HP Units

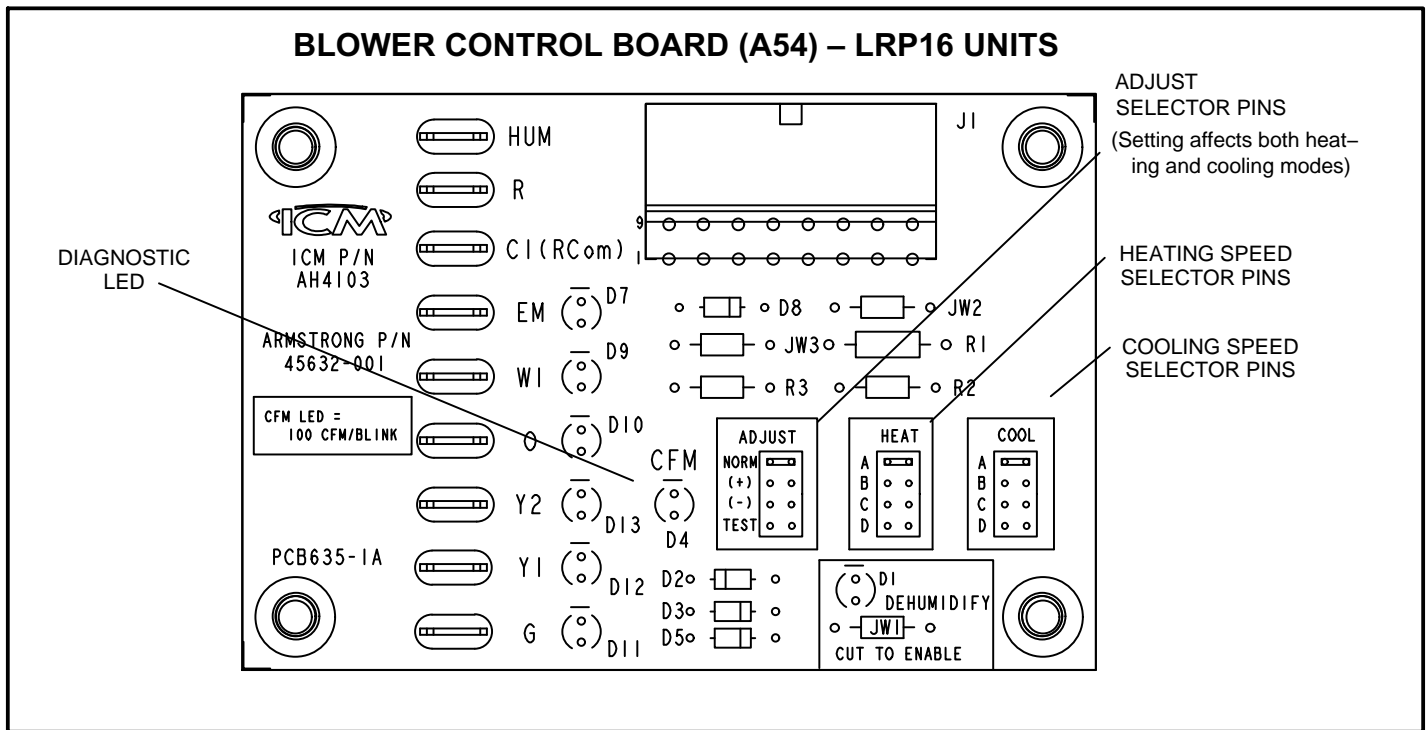

FIGURE 11. Blower Control Board (A54) – ECM Motor – LRP16GE / LRP16HP Units

Figure 10 shows the blower control utilized with PSC motors. On LRP14AC and HP units that are equipped with the PSC motor and a blower control, the indoor blower is energized by the G terminal on the room thermostat.

On LRP14DF and GE units that are equipped with the PSC motor and a blower control, the indoor blower is energized by the ignition control.

Blower Control — Units with Constant Torque Motors

LRP14 units that are equipped with constant torque blower motors are energized from the W, G and Y 24 volt terminals from the room thermostat, which are connected to the control board in each unit. The constant torque motor is capable of maintaining a specified CFM throughout the external static range. Constant torque units are not equipped with a separate blower control.

BLOWER SPEED ADJUSTMENT / OPERATION LRP14 UNITS

Speed Taps — PSC Units Only

Adjust the speed taps on the motor, if needed, to achieve the correct airflow in units equipped with PSC motors.

Factory positions for the blower speed jumpers are given in the PSC unit wiring diagrams. Use tables on pages 13-19 to determine the correct air volume for operation in heat and cool modes.

Blower Speeds — Constant Torque Units

Fan speed on units equipped with constant torque motors is field-adjustable. See blower CFM chart for unit size.

Blower Speeds — LRP16GE/HP Units

Fan speed on the HEAT and COOL stage air volume selections are made by jumper pins.

Continuous Fan Operation

When the thermostat is set for “Continuous Fan” operation and there is no demand for heating or cooling, the blower on units with PSC motors will operate at cooling speed. On units with constant torque motors, the blower will operate at low speed with a G call.

NOTE - With the proper thermostat and sub-base, continuous blower operation is possible by closing the R to G circuit. Cooling blower delay is also functional in this mode.

Blower Control Board (A54) LRP16GE/HP Units

These units are equipped with a variable-speed motor which is controlled by a blower control board. See figure 11.

On LRP16GE/HP units equipped with ECM motor and a two-stage electronic blower control, the indoor blower is energized by the ignition control.

The variable speed motor that is capable of maintaining a specified CFM throughout the external static range. A particular CFM can be obtained by positioning jumpers (COOL, HEAT, and ADJUST) on the blower control board. The HEAT and COOL jumpers are labeled A, B, C and D. Each of the letters corresponds with an air volume (CFM) setting. The ADJUST jumper is labeled NORM, +, - and Test. The + and - pin settings are used to add or subtract a percentage of the CFM selected. The Test jumper is used to operate the motor in the test mode. See figure 11.

Factory settings for the blower speed jumpers are given in the wiring diagram in figure 11. Use the blower data tables in this manual to determine the correct air volume for operation in heat and cool mode.

The CFM LED located on the blower control board flashes one time per 100 cfm to indicate selected blower speed. For example, if the unit is operating at 1000 CFM, CFM LED will flash 10 times. If the CFM is 1150, CFM LED will flash 11 full times plus one fast or half flash.

At times the light may appear to flicker or glow. This takes place when the control is communicating with the motor between cycles. This is normal operation.

Read through the jumper settings section before adjusting the jumper to obtain the appropriate blower speed.

To change jumper positions, gently pull the jumper off the pins and place it on the desired set of pins. The following section outlines the different jumper selections available and conditions associated with each one. Refer to figure 11.

After the CFM for each application has been determined, the jumper settings must be adjusted to reflect those given in the blower tables. From the tables, determine which row most closely matches the desired CFM. Once a specific row has been chosen (+, NORMAL, or -), CFM volumes from other rows cannot be used. Below are descriptions of the jumper selections.

The variable speed motor slowly ramps up to and down from the selected air flow during both cooling and heating demand. This minimizes noise and eliminates the initial blast of air when the blower is initially energized.

ADJUST

The **ADJUST** pins allow the motor to run at normal speed, approximately 15 percent higher, or approximately 15 percent lower than normal speed. The blower data tables give three rows (+, NORMAL, and -) with their respective CFM volumes. Notice that the normal adjustment setting for heat speed position C in table 1 is 900 CFM. The + adjustment setting for that position is 1035 CFM and for the - adjustment setting is 765 CFM. After the adjustment setting has been determined, choose the remaining speed settings from those offered in the table in that row.

The TEST pin is available to bypass the blower control and run the motor at approximately 70 percent to make sure that the motor is operational. This is used mainly in troubleshooting. The G terminal must be energized for the motor to run.

COOL

The **COOL** jumper is used to determine the CFM during cooling operation. This jumper selection is activated for cooling when Y1 is energized.

The blower motor runs at 80 percent of the selected air flow for the first 7-1/2 minutes of each cooling demand. This feature allows for greater humidity removal and saves energy.

In the cooling mode, the blower control board delays blower operation for 5 seconds after the compressor starts. The blower continues to operate for 90 seconds after the compressor is de-energized.

HEAT

The **HEAT** jumper is used to determine CFM during gas heat operation only. These jumper selections are activated only when W1 is energized.

In the heating mode, the blower control board delays blower operation for 30 seconds after the flame is established. The blower continues to operate for 90 seconds after the gas valve is de-energized.

CONTINUOUS FAN

When the thermostat is set for "Continuous Fan" operation and there is no demand for heating or cooling, the blower control will provide 50 percent of the **COOL** CFM selected.

NOTE - With the proper thermostat and subbase, continuous blower operation is possible by closing the R to G circuit. Cooling blower delay is also functional in this mode.

DEHUMIDIFICATION

The blower control board includes an HUM terminal which provides for connection of a humidistat. The JW1 resistor on the blower control board must be cut to activate the HUM terminal. The humidistat must be wired to open on humidity rise. When the dehumidification circuit is used, the variable speed motor will reduce the selected air flow rate by 25 percent when humidity levels are high. An LED (D1) lights when the blower is operating in the dehumidification mode.

NOTE - This unit is not approved for installation as part of a zoning system.

BLOWER DATA — LRP14HP

LRP14HP24 BLOWER PERFORMANCE (CT Motor)

External Static Pressure in w.g.	Air Volume at Specific Blower Taps (cfm)				
	Tap 1	Tap 2	Tap 3	¹ Tap 4 (Low Static Electric Heat)	¹ Tap 5 (High Static Electric Heat)
0.10	680	890	1000	890	---
0.20	590	830	960	830	---
0.30	550	800	930	800	---
0.40	500	760	880	760	---
0.50	450	710	840	---	840
0.60	380	680	810	---	810
0.70	---	640	770	---	770
0.80	---	600	730	---	730

NOTE - All air data measured external to unit with dry coil and less filter.

¹ Taps 4 and 5 are used with Optional Electric Heat. Refer to Electric Heat nameplate for proper heat tap selection.

LRP14HP30 BLOWER PERFORMANCE (CT Motor)

External Static Pressure in w.g.	Air Volume at Specific Blower Taps (cfm)				
	Tap 1	Tap 2	Tap 3	¹ Tap 4 (Low Static Electric Heat)	¹ Tap 5 (High Static Electric Heat)
0.10	680	1100	1180	1100	---
0.20	640	1070	1160	1070	---
0.30	600	1050	1130	1050	---
0.40	570	1020	1090	1020	---
0.50	530	990	1070	---	1070
0.60	490	960	1040	---	1040
0.70	---	930	1010	---	1010
0.80	---	900	960	---	960

NOTE - All air data measured external to unit with dry coil and less filter.

¹ Taps 4 and 5 are used with Optional Electric Heat. Refer to Electric Heat nameplate for proper heat tap selection.

LRP14HP36 BLOWER PERFORMANCE (CT Motor)

External Static Pressure in w.g.	Air Volume at Specific Blower Taps (cfm)				
	Tap 1	Tap 2	Tap 3	¹ Tap 4 (Low Static Electric Heat)	¹ Tap 5 (High Static Electric Heat)
0.10	900	1330	1520	1330	---
0.20	860	1280	1490	1280	---
0.30	830	1250	1460	1250	---
0.40	770	1230	1430	1230	---
0.50	720	1200	1380	---	1380
0.60	680	1180	1340	---	1340
0.70	620	1130	1250	---	1250
0.80	560	1100	1170	---	1170

NOTE - All air data measured external to unit with dry coil and less filter.

¹ Taps 4 and 5 are used with Optional Electric Heat. Refer to Electric Heat nameplate for proper heat tap selection.

LRP14HP42 BLOWER PERFORMANCE (PSC Motor)

External Static Pressure in w.g.	Air Volume at Specific Blower Taps (cfm)		
	Tap 2	Tap 3	Tap 4
0.10	1790	1500	1070
0.20	1740	1470	1050
0.30	1670	1430	1010
0.40	1590	1370	980
0.50	1510	1310	920
0.60	1410	1240	870
0.70	1310	1140	820
0.80	1210	1010	690

NOTE - All air data measured external to unit with dry coil and less filter.

LRP14HP48 BLOWER PERFORMANCE (PSC Motor)

External Static Pressure in w.g.	Air Volume at Specific Blower Taps (cfm)		
	Tap 2	Tap 3	Tap 4
0.10	1970	1730	1520
0.20	1890	1690	1480
0.30	1790	1600	1430
0.40	1690	1540	1370
0.50	1600	1450	1310
0.60	1510	1360	1230
0.70	1400	1270	1140
0.80	1280	1150	1050

NOTE - All air data measured external to unit with dry coil and less filter.

LRP14HP60 BLOWER PERFORMANCE (CT Motor)

External Static Pressure in w.g.	Air Volume at Specific Blower Taps (cfm)				
	Tap 1	Tap 2	Tap 3	¹ Tap 4 (Low Static Electric Heat)	¹ Tap 5 (High Static Electric Heat)
0.10	1400	1920	2240	1920	---
0.20	1320	1870	2200	1870	---
0.30	1260	1820	2140	1820	---
0.40	1200	1770	2100	1770	---
0.50	1120	1720	2060	---	2060
0.60	1060	1670	2020	---	2020
0.70	980	1450	1980	---	1980
0.80	900	1360	1950	---	1950

NOTE - All air data measured external to unit with dry coil and less filter.

¹ Taps 4 and 5 are used with Optional Electric Heat. Refer to Electric Heat nameplate for proper heat tap selection.

BLOWER DATA — LRP14DF

¹ LRP14DF24 BLOWER PERFORMANCE (CT Motor)

External Static Pressure in w.g.	Air Volume at Specific Blower Taps (cfm)		
	Tap 1	Tap 2	Tap 3
0.10	680	890	1000
0.20	590	830	960
0.30	550	800	930
0.40	500	760	880
0.50	450	710	840
0.60	380	680	810
0.70	---	640	770
0.80	---	600	730

NOTE - All air data measured external to unit with dry coil and less filter.

¹ LRP14DF30 BLOWER PERFORMANCE (CT Motor)

External Static Pressure in w.g.	Air Volume at Specific Blower Taps (cfm)		
	Tap 1	Tap 2	Tap 3
0.10	680	1100	1180
0.20	640	1070	1160
0.30	600	1050	1130
0.40	570	1020	1090
0.50	530	990	1070
0.60	490	960	1040
0.70	---	930	1010
0.80	---	900	960

NOTE - All air data measured external to unit with dry coil and less filter.

1 LRP14DF36 BLOWER PERFORMANCE (CT Motor)

External Static Pressure in w.g.	Air Volume at Specific Blower Taps (cfm)		
	Tap 1	Tap 2	Tap 3
0.10	900	1330	1520
0.20	860	1280	1490
0.30	830	1250	1460
0.40	770	1230	1430
0.50	720	1200	1380
0.60	680	1180	1340
0.70	620	1130	1250
0.80	560	1100	1170

NOTE - All air data measured external to unit with dry coil and less filter.

1 MOTOR SPEED TAP SETTINGS (24, 30 and 36 Models with Constant Torque Blower Motor Only)

Tap 1	Fan Only
Tap 2	Low Static Cooling
Tap 3	High Static Cooling
Tap 4	Nominal 0.2 exterior static pressure
Tap 5	Nominal 0.5 exterior static pressure
Taps 4 and 5	Taps 4 and 5 designated for Heating mid-point temperature rise

LRP14DF42 BLOWER PERFORMANCE (PSC Motor)

External Static Pressure in w.g.	Air Volume at Specific Blower Taps (cfm)		
	Tap 2	Tap 3	Tap 4
0.10	1790	1500	1070
0.20	1740	1470	1050
0.30	1670	1430	1010
0.40	1590	1370	980
0.50	1510	1310	920
0.60	1410	1240	870
0.70	1310	1140	820
0.80	1210	1010	690

NOTE - All air data measured external to unit with dry coil and less filter.

LRP14DF48 BLOWER PERFORMANCE (PSC Motor)

External Static Pressure in w.g.	Air Volume at Specific Blower Taps (cfm)		
	Tap 2	Tap 3	Tap 4
0.10	1970	1730	1520
0.20	1890	1690	1480
0.30	1790	1600	1430
0.40	1690	1540	1370
0.50	1600	1450	1310
0.60	1510	1360	1230
0.70	1400	1270	1140
0.80	1280	1150	1050

NOTE - All air data measured external to unit with dry coil and less filter.

1 LRP14DF60 BLOWER PERFORMANCE (CT Motor)

External Static Pressure in w.g.	Air Volume at Specific Blower Taps (cfm)		
	Tap 1	Tap 2	Tap 3
0.10	1400	1920	2240
0.20	1320	1870	2200
0.30	1260	1820	2140
0.40	1200	1770	2100
0.50	1120	1720	2060
0.60	1060	1670	2020
0.70	980	1450	1980
0.80	900	1360	1950

NOTE - All air data measured external to unit with dry coil and less filter.

1 MOTOR SPEED TAP SETTINGS (For 60 Model with Constant Torque Blower Motor Only)

Tap 1	Fan Only
Tap 2	Low Static Cooling
Tap 3	High Static Cooling
Tap 4	Nominal 0.2 exterior static pressure
Tap 5	Nominal 0.5 exterior static pressure
Taps 4 and 5	Taps 4 and 5 designated for Heating mid-point temperature rise

BLOWER DATA — LRP14AC

LRP14AC24 and LRP14AC30 BLOWER PERFORMANCE (PSC Motor)

External Static Pressure in w.g.	Air Volume at Specific Blower Taps (cfm)			
	Tap 2	Tap3	Tap 4	Tap 5
0.10	1350	1110	970	840
0.20	1310	1080	950	820
0.30	1270	1050	920	800
0.40	1210	1000	890	770
0.50	1140	970	850	750
0.60	1080	920	820	720
0.70	1020	870	770	680
0.80	950	800	710	620

NOTE - All air data measured external to unit with dry coil and less filter.

LRP14AC36 BLOWER PERFORMANCE (PSC Motor)

External Static Pressure in w.g.	Air Volume at Specific Blower Taps (cfm)		
	Tap 2	Tap 3	Tap 4
0.10	1460	1350	1080
0.20	1380	1280	1030
0.30	1280	1200	960
0.40	1190	1130	900
0.50	1100	1060	830
0.60	990	950	750
0.70	880	870	700
0.80	760	750	650

NOTE - All air data measured external to unit with dry coil and less filter.

LRP14AC42 BLOWER PERFORMANCE (PSC Motor)

External Static Pressure in w.g.	Air Volume at Specific Blower Taps (cfm)		
	Tap 2	Tap 3	Tap 4
0.10	1790	1500	1070
0.20	1740	1470	1050
0.30	1670	1430	1010
0.40	1590	1370	980
0.50	1510	1310	920
0.60	1410	1240	870
0.70	1310	1140	820
0.80	1210	1010	690

NOTE - All air data measured external to unit with dry coil and less filter.

LRP14AC48 BLOWER PERFORMANCE (PSC Motor)

External Static Pressure in w.g.	Air Volume at Specific Blower Taps (cfm)		
	Tap 2	Tap 3	Tap 4
0.10	1970	1730	1520
0.20	1890	1690	1480
0.30	1790	1600	1430
0.40	1690	1540	1370
0.50	1600	1450	1310
0.60	1510	1360	1230
0.70	1400	1270	1140
0.80	1280	1150	1050

NOTE - All air data measured external to unit with dry coil and less filter.

LRP14AC60 BLOWER PERFORMANCE (CT Motor)

External Static Pressure in w.g.	Air Volume at Specific Blower Taps (cfm)				
	Tap 1	Tap 2	Tap 3	¹ Tap 4 (Low Static Electric Heat)	¹ Tap 5 (High Static Electric Heat)
0.10	2240	1920	1400	1920	---
0.20	2200	1870	1320	1870	---
0.30	2140	1820	1260	1820	---
0.40	2100	1770	1200	1770	---
0.50	2060	1720	1120	---	1120
0.60	2020	1670	1060	---	1060
0.70	1980	1450	980	---	980
0.80	1950	1360	900	---	900

NOTE - All air data measured external to unit with dry coil and less filter.

¹ Taps 4 and 5 are used with Optional Electric Heat. Refer to Electric Heat nameplate for proper heat tap selection.

BLOWER DATA — LRP14GE

BLOWER PERFORMANCE (PSC Motor 24-48 Models) (CT Motor 60 Models)

External Static Pressure in w.g.	Air Volume at Specific Blower Taps (cfm)															
	LRP14GE24 LRP14GE30				LRP14GE36			LRP14GE42			LRP14GE48			¹ LRP14GE60		
	Tap 2	Tap 3	Tap 4	Tap 5	Tap 2	Tap 3	Tap 4	Tap 2	Tap 3	Tap 4	Tap 2	Tap 3	Tap 4	Tap 1	Tap 2	Tap 3
0.10	1350	1110	970	840	1460	1350	1080	1790	1500	1070	1970	1730	1520	1400	1920	2240
0.20	1310	1080	950	820	1380	1280	1030	1740	1470	1050	1890	1690	1480	1320	1870	2200
0.30	1270	1050	920	800	1280	1200	960	1670	1430	1010	1790	1600	1430	1260	1820	2140
0.40	1210	1000	890	770	1190	1130	900	1590	1370	980	1690	1540	1370	1200	1770	2100
0.50	1140	970	850	750	1100	1060	830	1510	1310	920	1600	1450	1310	1120	1720	2060
0.60	1080	920	820	720	990	950	750	1410	1240	870	1510	1360	1230	1060	1670	2020
0.70	1020	870	770	680	880	870	700	1310	1140	820	1400	1270	1140	980	1450	1980
0.80	950	800	710	620	760	750	650	1210	1010	690	1280	1150	1050	900	1360	1950

NOTE - All air data measured external to unit with dry coil and less filter.

¹ MOTOR SPEED TAP SETTINGS (For 60 Model with Constant Torque Blower Motor Only)

Tap 1	Fan Only
Tap 2	Low Static Cooling
Tap 3	High Static Cooling
Taps 4 and 5	Taps 4 and 5 designated for Heating mid-point temperature rise
Tap 4	Nominal 0.2 exterior static pressure
Tap 5	Nominal 0.5 exterior static pressure

BLOWER DATA — LRP16GE

LRP16GE24 Blower Performance

0 through 0.80 in. w.g. External Static Pressure Range

“ADJUST” Jumper Setting	Blower Control Jumper Speed Positions											
	“COOL” Speed – cfm				“HEAT” Speed – cfm				“CONTINUOUS FAN” Speed – cfm			
	A	B	C	D	A	B	C	D	A	B	C	D
+	1100	880	660	440	1100	1000	900	815	550	440	330	220
NORM	1000	800	600	400	1100	1000	900	815	500	400	300	200
—	900	720	540	360	1100	1000	900	815	450	360	270	180

NOTE – All air data is measured external to unit without air filters.

NOTE – 1st Stage airflow is 70% of 2nd Stage airflow (full capacity) in cooling mode. In heating mode, low stage airflow is optimized for a 40°F temperature rise.

LRP16GE36 Blower Performance

0 through 0.80 in. w.g. External Static Pressure Range

“ADJUST” Jumper Setting	Blower Control Jumper Speed Positions											
	“COOL” Speed – cfm				“HEAT” Speed – cfm				“CONTINUOUS FAN” Speed – cfm			
	A	B	C	D	A	B	C	D	A	B	C	D
+	1540	1320	1100	880	1400	1200	1100	975	770	660	550	440
NORM	1400	1200	1000	800	1400	1200	1100	975	700	600	500	400
—	1260	1080	900	720	1400	1200	1100	975	630	540	450	360

NOTE – All air data is measured external to unit without air filters.

NOTE – 1st Stage airflow is 70% of 2nd Stage airflow (full capacity) in cooling mode. In heating mode, low stage airflow is optimized for a 40°F temperature rise.

LRP16GE48 Blower Performance

0 through 0.80 in. w.g. External Static Pressure Range

“ADJUST” Jumper Setting	Blower Control Jumper Speed Positions											
	“COOL” Speed – cfm				“HEAT” Speed – cfm				“CONTINUOUS FAN” Speed – cfm			
	A	B	C	D	A	B	C	D	A	B	C	D
+	1980	1760	1540	1320	1350	1200	1100	1000	990	880	770	660
NORM	1800	1600	1400	1200	1350	1200	1100	1000	900	800	700	600
—	1620	1440	1260	1080	1350	1200	1100	1000	810	720	630	540

NOTE – All air data is measured external to unit without air filters.

NOTE – 1st Stage airflow is 70% of 2nd Stage airflow (full capacity) in cooling mode. In heating mode, low stage airflow is optimized for a 40°F temperature rise.

LRP16GE60 Blower Performance

0 through 0.80 in. w.g. External Static Pressure Range

“ADJUST” Jumper Setting	Blower Control Jumper Speed Positions											
	“COOL” Speed – cfm				“HEAT” Speed – cfm				“CONTINUOUS FAN” Speed – cfm			
	A	B	C	D	A	B	C	D	A	B	C	D
+	2200	1980	1760	1540	1480	1380	1280	1180	1100	990	880	770
NORM	2000	1800	1600	1400	1480	1380	1280	1180	1000	900	800	700
—	1800	1620	1440	1260	1480	1380	1280	1180	900	810	720	630

NOTE – All air data is measured external to unit without air filters.

NOTE – 1st Stage airflow is 70% of 2nd Stage airflow (full capacity) in cooling mode. In heating mode, low stage airflow is optimized for a 40°F temperature rise.

BLOWER DATA — LRP16HP

LRP16HP24 Blower Performance

0 through 0.80 in. w.g. External Static Pressure Range

“ADJUST” Jumper Setting	Blower Control Jumper Speed Positions											
	“COOL” Speed – cfm				“HEAT” Speed – cfm				“CONTINUOUS FAN” Speed – cfm			
	A	1B	C	D	A	1B	C	D	A	B	C	D
+	1100	880	660	440	1150	1035	690	690	550	440	330	220
NORM	1000	800	600	400	1000	900	600	600	500	400	300	200
—	900	720	540	360	1000	900	600	600	450	360	270	180

¹ Factory Settings.

NOTE – All air data is measured external to unit without air filters.

NOTE – 1st Stage airflow is 70% of 2nd Stage airflow (full capacity) in cooling mode.

LRP16HP36 Blower Performance

0 through 0.80 in. w.g. External Static Pressure Range

“ADJUST” Jumper Setting	Blower Control Jumper Speed Positions											
	“COOL” Speed – cfm				“HEAT” Speed – cfm				“CONTINUOUS FAN” Speed – cfm			
	A	1B	C	D	A	1B	C	D	A	B	C	D
+	1430	1320	1100	880	1495	1380	1150	1150	715	660	550	440
NORM	1300	1200	1000	800	1300	1250	1000	1000	650	600	500	400
—	1170	1080	900	720	1300	1200	1000	1000	585	540	450	360

¹ Factory Settings.

NOTE – All air data is measured external to unit without air filters.

NOTE – 1st Stage airflow is 70% of 2nd Stage airflow (full capacity) in cooling mode.

LRP16HP48 Blower Performance

0 through 0.80 in. w.g. External Static Pressure Range

“ADJUST” Jumper Setting	Blower Control Jumper Speed Positions											
	“COOL” Speed – cfm				“HEAT” Speed – cfm				“CONTINUOUS FAN” Speed – cfm			
	A	1B	C	D	A	1B	C	D	A	B	C	D
+	1980	1760	1540	1320	2070	1840	1610	1610	990	880	770	660
NORM	1800	1600	1400	1200	1800	1600	1400	1400	900	800	700	600
—	1620	1440	1260	1080	1800	1600	1400	1400	810	720	630	540

¹ Factory Settings.

NOTE – All air data is measured external to unit without air filters.

NOTE – 1st Stage airflow is 70% of 2nd Stage airflow (full capacity) in cooling mode.

LRP16HP60 Blower Performance

0 through 0.80 in. w.g. External Static Pressure Range

“ADJUST” Jumper Setting	Blower Control Jumper Speed Positions											
	“COOL” Speed – cfm				“HEAT” Speed – cfm				“CONTINUOUS FAN” Speed – cfm			
	A	1B	C	D	A	1B	C	D	A	B	C	D
+	2200	1980	1760	1540	2300	2070	1840	1840	1100	990	880	770
NORM	2000	1800	1600	1400	2000	1800	1600	1600	1000	900	800	700
—	1800	1620	1440	1260	2000	1800	1600	1600	900	810	720	630

¹ Factory Settings.

NOTE – All air data is measured external to unit without air filters.

NOTE – 1st Stage airflow is 70% of 2nd Stage airflow (full capacity) in cooling mode.

DEFROST CONTROL CMC1

NOTE - For geographic areas that experience low temperature and high humidity conditions (below 32°F and above 80% RH), the defrost timer pin must be field set at installation to a 60 or 30 minute defrost interval in order to ensure reliable system operation while in heating mode.

LRP14HP/DF and LRP16HP units are equipped with a defrost control that includes the combined functions of time/temperature defrost control, defrost relay, diagnostic LEDs and a low voltage terminal strip. See figure 12.

The control provides automatic switching from call for heating to defrost mode and back. During the compressor cycle (call for defrost), the control accumulates compressor run time at 30, 60 or 90-minute field-adjustable intervals. If the defrost thermostat is closed when the selected compressor run time interval ends, the defrost relay is energized and the defrost begins.

-1 Builds: the **defrost timing jumper** is factory-installed to provide a 90-minute defrost interval. **-2 Builds:** the **defrost timing** is factory set to provide a 30-minute defrost interval. If the timing selector jumper is not in place, the control defaults to a 90-minute defrost interval. The maximum defrost period is 14 minutes and is not adjustable. See figure 12 for the location of the defrost interval timing pins.

A **test option** is provided for troubleshooting. The test mode may be started any time the unit is in the heating mode and the defrost thermostat is closed or jumpered. If the jumper is in the TEST position at power up, the control will ignore the test pins. When the jumper is placed across the TEST pins for 2 seconds, the control will enter the defrost mode. If the jumper is removed before an additional 5-second period has elapsed (7 seconds total), the unit will remain in defrost mode until the defrost thermostat opens or 14 minutes have passed. If the jumper is not removed until after the additional 5-second period has elapsed, the defrost will terminate and the test option will not function again until the jumper is removed and reapplied.

NOTE - On early defrost controls, the defrost timing jumper must be in the 90-minute defrost interval before testing the defrost mode or the control will not enter defrost test mode.

The defrost control includes a **compressor delay** function which cycles the compressor off for 30 seconds while going into and coming out of the defrost cycle. This function is activated when the jumper is removed from the compressor delay pins.

NOTE - The 30-second compressor delay is not functional when the TEST pins are jumpered.

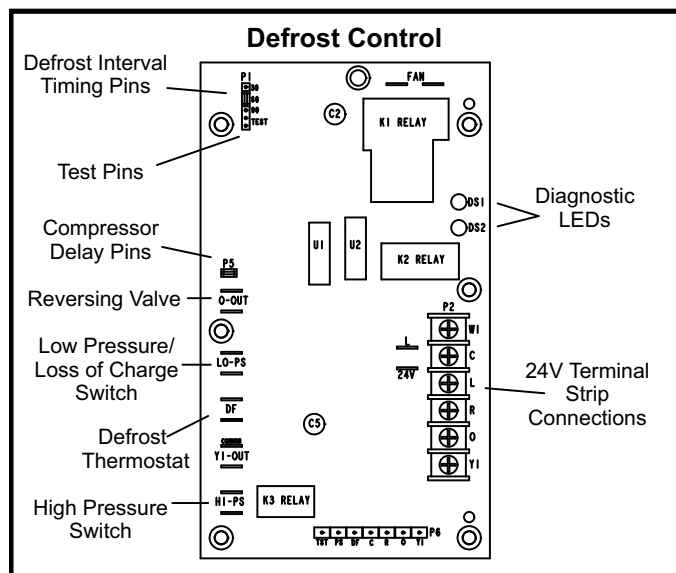

FIGURE 12

The **defrost thermostat (S6)** is located on the outdoor coil, near the bottom of the coil, affixed to the 3/8" stub. When the defrost thermostat senses a coil temperature of 42°F or cooler, the thermostat contacts close and send a signal to the defrost control to begin the defrost timing. The defrost thermostat also terminates the defrost when the coil distributor tube temperature warms to 70°F.

The defrost control includes **HI-PS and LO-PS terminals** to receive signals from the unit high pressure switch and loss of charge switch.

During a single demand cycle, the defrost control locks out compressor operation after the fifth time that the circuit is interrupted by any pressure switch wired to the control. In addition, the diagnostic LEDs indicate a locked-out pressure switch after the fifth open pressure switch occurrence. Compressor operation remains locked out until power to the control is interrupted, then re-established, or until the jumper is applied to the TEST pins for 0.5 seconds.

NOTE - The defrost control ignores input from the loss of charge switch terminals as follows:

- During the test mode;
- During the defrost cycle;
- During the 90-second start-up period;
- During the first 90 seconds following a reversing valve switch between the heating and cooling modes.

EXCEPTION -- If the TEST pins are jumpered and the 5-minute delay is being bypassed, the LO-PS terminal signal is not ignored during the 90-second start-up period.

The defrost control includes two diagnostic LEDs. LED codes indicate operating status. The diagnostics codes are given in table 1.

TABLE 1
Defrost Control Diagnostic LEDs

Mode	Green LED (DS2)	Red LED (DS1)
No power to control	OFF	OFF
Normal Operation / Power to Control	Simultaneous Slow Flash	
Anti-Short Cycle Lockout	Alternating Slow Flash	
Low Pressure Switch Fault	OFF	Slow Flash
Low Pressure Switch Lockout	OFF	ON
High Pressure Switch Fault	Slow Flash	OFF
High Pressure Switch Lockout	ON	OFF

BLOWER COMPARTMENT

Access panels can easily be removed for service.

Blower Wheel

Blower wheel size varies between models. See SPECIFICATIONS.

⚠ DANGER



Disconnect power from unit and wait at least five minutes to allow capacitors to discharge before attempting to adjust motor speed tap settings. Failure to wait may cause personal injury or death.

REFRIGERATION COMPONENTS

Compressor B1 – LRP14 Units

All LRP14 series units utilize a scroll compressor. Compressors are energized by the K1 contactor found in the unit control box. Compressor specifications are found in the “ELECTRICAL DATA” section in this manual.

Compressor B1 – LRP16GE/HP Units

All LRP16GE units utilize a two-stage Copeland scroll compressor. Compressors are energized by the K1 contactor found in the unit control box. Compressor specifications are found in the “ELECTRICAL DATA” section in this manual.

Crankcase Heater HR1

All DF units have compressor crankcase heaters factory installed to protect the compressor if the gas backup heat is used for extended periods of time.

On all other units, the crankcase heater is an available option.

⚠ WARNING

Electrical shock hazard. Compressor must be grounded. Do not operate without protective cover over terminals. Disconnect power before removing protective cover. Discharge capacitors before servicing unit. Failure to follow these precautions could cause electrical shock resulting in injury or death.

Condenser Fan B4 / Fan Motor B3 – LRP14 Units

LRP14 series units are equipped with either a constant-torque blower motor or an indoor PSC motor. The constant torque motor is capable of maintaining a specified CFM throughout the external static range. On units equipped with the PSC blower motor, a particular CFM can be obtained by adjusting the speed tap.

All LRP14 series units use single phase condenser fan motors. Specifications for the condenser fans are at the front of this manual. See figure 13 for fan and motor replacement dimensions.

Condenser Fan B4 / Fan Motor B3 – LRP16GE/HP Units

LRP16GE/HP units are equipped with a variable-speed direct-drive blower operated by a variable-speed ECM motor. The ECM motor maintains a specified air volume from 0 through 0.80 in. w.g. static range.

All LRP16GE/HP units use single phase condenser fan motors. Specifications for the condenser fans are at the front of this manual. See figure 13 for fan and motor replacement dimensions.

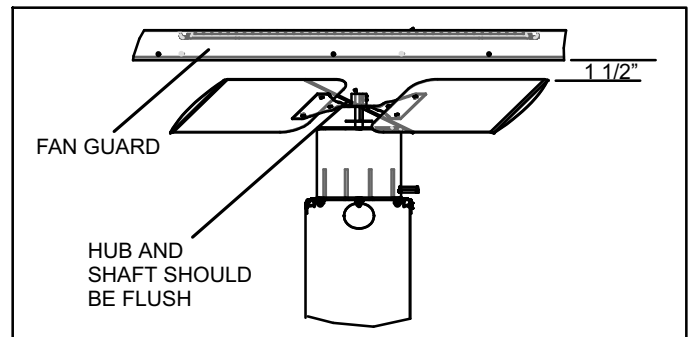

FIGURE 13

Reversing Valve L1

Reversing valve L1 has a 24 volt solenoid coil which reverses refrigerant flow during unit operation in all LRP14HP, LRP14DF and LRP16HP units. The reversing valve is in the refrigerant circuit vapor line. The reversing valve coil is energized during cooling demand and during defrost.

Low Pressure Switch S79 (LRP14GE, AC, LRP16GE Units)

S79 is a N.C. auto-reset low pressure switch located on the suction line. The switch shuts off the compressor when suction pressure falls below the factory setting. The switch is ignored during the first 90 seconds of compressor start up and during defrost operation. On the LRP14/16 series units, the switch is set to open at 25 ± 5 psi and close at 40 ± 5 psi. S79 is not adjustable.

Loss of Charge Pressure Switch S79 (LRP14HP-02 – LRP16HP Units)

The low pressure switch is an auto-reset N.C. switch that opens on pressure drop. The switch is wired into the defrost board low pressure terminals and is located on the liquid (high pressure) line. When suction pressure drops to 40 psig (275.8 kPa) the switch opens and the compressor is de-energized. When suction pressure rises to 90 psig (620.5 kPa) the pressure switch will close.

High Pressure Switch S4

S4 is a N.C. auto-reset high pressure switch located on the discharge line. The switch shuts off the compressor when discharge pressure rises above the factory setting. The switch on LRP14/16 series units is set to open at 590 ± 10 psi and close at 418 ± 10 psi. S4 is not adjustable.

Float Switch

A float switch is included with the downflow kit or can be ordered as an accessory (float switch is factory installed on the LRP16 series). The float switch is designed to prevent condensate water from overflowing the condensate pan due to a restriction in the condensate drain line.

The float switch is field-installed in the condensate drain pan near the drain exit (float switch is factory installed on the LRP16 series). Refer to the installation instruction for the float switch kit or the downflow kit for location and cutting of the red wire located in the blower compartment.

ELECTRIC HEAT

Matchups and Ratings

Matchups and ratings are listed with "ELECTRICAL DATA".

Electric Heat Components

See figure 14 for electric heat parts arrangement.

Limit Switches 1, 2, 3 and 4

Limit switches 1, 2, 3 and 4 are N.C. auto-reset high temperature limits located on the electric heat vest panel. Each heating element is wired in series with a high temperature limit. When the limit opens, the corresponding heating element is de-energized. All other heating elements remain energized. The limits will automatically close when temperatures return to normal. Limit rating will be on front side.

Heating Element HE1 through HE4

Heating elements are composed of helix-wound bare nichrome wire exposed directly to the air stream. The elements are supported by insulators mounted to the wire frame. Each element is energized independently by a corresponding relay located on the heat vest panel. Once energized, heat transfer is instantaneous.

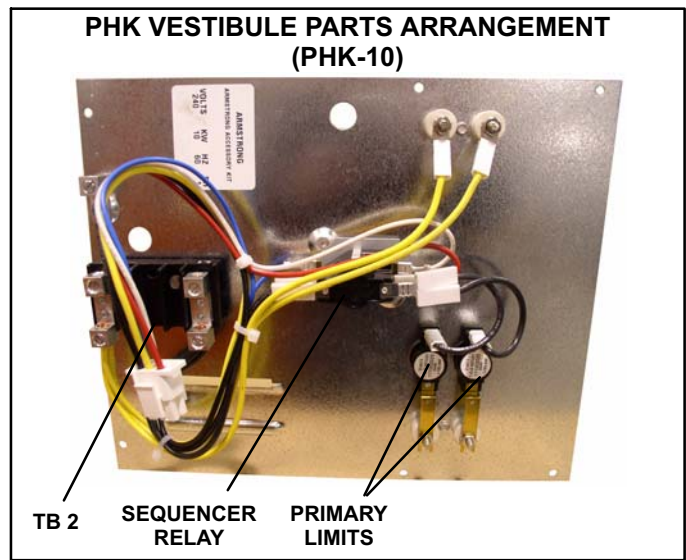

FIGURE 14

Terminal Strip TB2 PHK-05, -07, -10

All heating elements require either a second-line voltage power source or the use of the single-point power connection kit. For electric heat sections without circuit breakers or fuses, line voltage connections are made to terminal strip TB2.

Sequencer Relays 1 and 2

Relays 1 and 2 are N.O. sequencer relays with a resistive element for a coil and bi-metal disk which actuates the contacts. The relays are located on the electric heat vest panel and are energized by a 24V heating demand (W1 and W2) via jack/plug P2 which is used to connect electric heat to the blower control circuit. When energized, the internal resistance heats the bi-metal disk causing the contacts to close. When the relay is de-energized the disk cools and the contacts open. The relays energize different stages of heat, as well as the blower. The blower is always first on and last off.

NOTE - As of 2015, all electric heaters must be equipped with a second relay to break the line voltage on the return side so that a path for the electrical voltage is broken on both sides if an element goes to ground.

Circuit Breaker CB1 and CB2 (option) PHK-15, -20

Line voltage connections are made to circuit breakers CB1 and CB2 in electric heat sections with circuit breakers. Table 2 shows amp rating for each circuit breaker used. Two-pole circuit breakers are used.

TABLE 2

Circuit Breakers		
UNIT	CB1 AMPS	CB2 AMPS
PHK15CP	60 AMPS	30 AMPS
PHK20CP	60 AMPS	60 AMPS

GAS HEAT

Gas Valve (GV1) LRP16GE Units

The LRP16GE uses a gas valve manufactured by White-Rodgers. The valve is two-stage internally redundant to assure safety shut off. If the valve must be replaced the same type valve must be used. The valve can be converted to LP (see options gas specifications for LP kit) and is adjustable on both high and low fire.

24VAC and gas control knob / switch are located on top of the valve. Terminals on the gas valve are connected to wires from the ignition control (A3). Inlet and outlet taps are located on the valve.

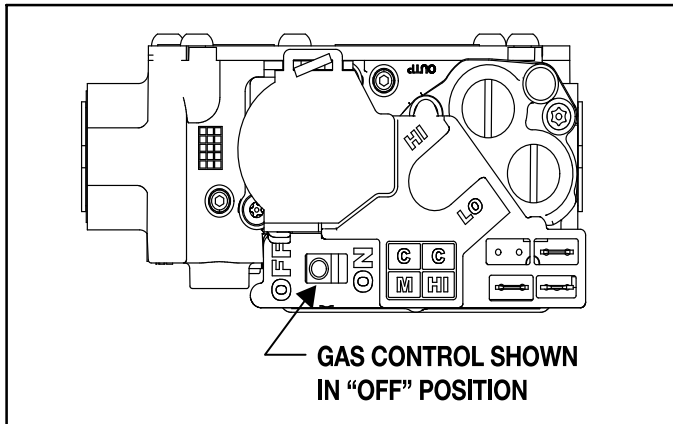

FIGURE 15

CHARGING

CAUTION

As with any mechanical equipment, contact with sharp sheet metal edges can result in personal injury. Take care while handling this equipment and wear gloves and protective clothing.

For maximum performance of the cooling system, the operating temperatures and pressure should be checked and subcooling determined at Standard ARI test conditions of 82° F outdoor temperature / 80° F indoor dry bulb / 67° F indoor wet bulb.

For maximum performance of the heat pump, the operating temperatures and pressure should be checked and subcooling determined at Standard ARI test conditions of 47° F outdoor temperature / 70° F indoor dry bulb.

If subcooling measurement deviates, refrigerant charge should be adjusted accordingly for maximum performance.

TABLE 3

AC Unit Cooling System Performance Values - LRP14		
Model	Suction Superheat + / - 3°	Liquid Subcooling + / - 2°
2 Ton		10
2.5 Ton		14
3 Ton	13	
3.5 Ton	12	
4 Ton	14	
5 Ton	17	
Based on outdoor ambient temperature of 82° F and indoor entering air of 80° F db, 67° F wb.		

TABLE 4

Heat Pump Cooling System Performance Values - LRP14HP/LRP16HP		
Model	Suction Superheat + / - 3°	Liquid Subcooling + / - 2°
2 Ton	18	
2.5 Ton	16	
3 Ton	14	
3.5 Ton		9
4 Ton		8
5 Ton		5
Based on outdoor ambient temperature of 82° F and indoor entering air of 80° F db, 67° F wb.		

TABLE 5

Heat Pump Heating System Performance Values - LRP14HP/LRP16HP	
Model	Liquid Subcooling + / - 2°
2 Ton	25
2.5 Ton	15
3 Ton	11
3.5 Ton	22
4 Ton	24
5 Ton	28
Based on outdoor ambient temperature of 47° F and indoor entering air of 70° F db.	

TABLE 6

Unit Cooling System Performance Values - LRP16GE	
Model	Liquid Subcooling + / - 3°
2 Ton	10
3 Ton	12
4 Ton	10
5 Ton	9
Based on outdoor ambient temperature of 82° F and indoor entering air of 80° F db, 67° F wb.	

MAINTENANCE

The heating and air conditioning system should be inspected and maintained twice each year (before the start of the cooling and heating seasons) by a licensed professional HVAC technician. The technician is expected to check the following items. **These checks may only be conducted by a licensed professional HVAC technician.**

1. Inspect component wiring for loose, worn or damaged connections. Check for any rubbing or pinching of wires. Confirm proper voltage plus amperage of outdoor unit.
2. Check the cleanliness of fan and blade condition (cracks) and clean or replace them, if necessary.
3. Inspect drain pan for debris and clean as necessary.
4. Inspect the condition of refrigerant piping and confirm that pipes are not rubbing copper-to-copper. Also, check the condition of the insulation on the refrigerant lines. Repair, correct, or replace as necessary.
5. Test capacitor. Replace as necessary.
6. Inspect contactor contacts for pitting or burn marks. Replace as necessary.
7. Check fan motor for worn bearings/bushings. Replace as necessary.
8. Inspect and **clean** coils, if necessary and note any damage to coils or signs of leakage.

Filters

1. Internal filter kits containing filter rails for 1 in. thick filters are available. Filters are not provided and must be field supplied. A filter is required, whether installed in the unit, in the ductwork or behind a filter grill in the conditioned area.

NOTE - If PCO is installed, an internal filter kit is not recommended.

2. Filters should be inspected monthly. Replace disposable filters or clean permanent-type filters as necessary. Dirty filters are the most common cause of inadequate heating or cooling performance. Replace existing filter with a filter of like type and size. **DO NOT** replace a permanent-type filter with a disposable filter. Install new/clean filters with the arrows on the side pointing in the direction of airflow.

Healthy Climate® Photocatalytic Oxidation (PCO) Air Purification Accessory

1. The Healthy Climate® PCO cartridge and UVA lamp require annual replacement. An annual maintenance kit is available that includes the PCO cartridge and UVA lamp. More frequent replacement may be required in applications with heavier dust or dirt loads or in applications where a lower MERV filter is installed before the Healthy Climate® PCO cartridge. The field supplied filter should be changed at least annually, or according to the manufacturers recommended replacement cycle.

General System Test with System Operating

1. Perform a general system test. Turn on the air conditioner to check operating functions such as the start-up and shut-off operation. Check for unusual noises or odors, and measure indoor/outdoor temperatures and system pressures as needed. Check the refrigerant charge per the charging sticker information on the unit.
2. Refer to the nameplate to determine the correct temperature rise for all gas units (GE / DF).
3. Verify that system total static pressure and airflow settings are within specific operating parameters.
4. Verify correct temperature drop across indoor coil.

POST START-UP CHECKLIST (GAS)

After the control circuit has been energized and the heating section is operating, make the following checks:

1. Use soap solution to check for gas leaks in the unit piping as well as the supply piping.
2. Check the supply gas pressure. It must be within the limits shown on rating nameplate. Supply pressure should be checked with all gas appliances in the building at full fire. At no time should the supply gas pressure exceed 10.5 inches w.c., nor drop below 5.0 inches w.c. for natural gas units. For propane gas, supply gas pressure should not drop below 11 inches w.c. If gas pressure is outside these limits, contact your gas supplier for corrective action.
3. Check for correct manifold gas pressures. See Check and Adjust Manifold Pressure.
4. Adjust temperature rise to the range specified on the rating plate.

Check and Adjust Manifold Pressure

After line pressure has been checked and adjusted, check manifold pressure. Refer to figure 16 for location of manifold pressure adjustment screw and pressure tap outlet.

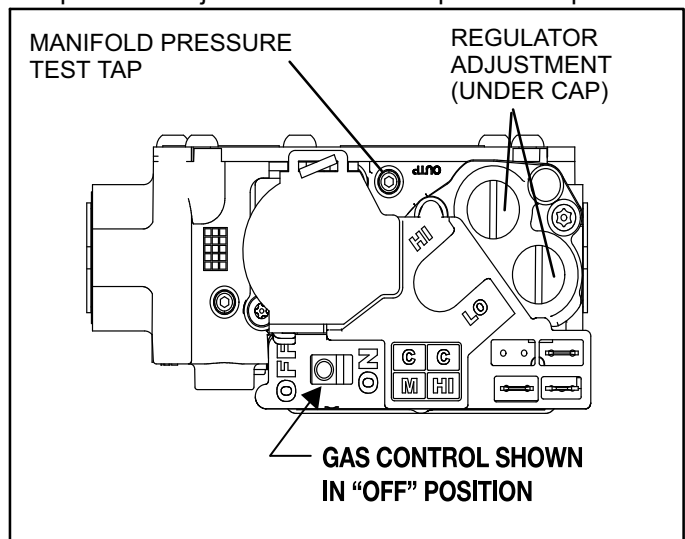

FIGURE 16

The gas valve is factory set and should not require adjustment. See the table below for pressures. The gas valve should completely and immediately cycle off in the event of gas or power failure. The manual shut-off knob or switch can be used to immediately shut off gas supply.

Manifold Pressure " w.c.		
1 st Stage Heat	Natural	2.0 ± 0.3
	LP	5.6 ± 0.3
2 nd Stage Heat	Natural	3.5 ± 0.3
	LP	10.0 ± 0.5

IMPORTANT

For safety, connect a shut-off valve between the manometer and the gas tap to permit shut off of gas pressure to the manometer.

1. Connect a test gauge to the outlet pressure tap on the gas valve. Start the unit and allow five minutes for the unit to reach steady state.
2. While waiting for the unit to stabilize, notice the flame. The flame should be stable without flashback and

should not lift from the burner head. Natural gas should burn blue. L.P. gas should burn mostly blue with some orange streaks.

3. After allowing the unit to stabilize for five minutes, record the manifold pressure.
4. Disconnect heating demand as soon as an accurate reading has been obtained.

Proper Gas Flow (Approximate)

Final first-stage and second-stage manifold pressures must be within the allowable ranges for the gas being used. **For Natural Gas:** Check the furnace rate by observing gas meter, making sure all other gas appliances are turned off. The test hand on the meter should be timed for at least one revolution. Note the number of seconds for one revolution.

$$\text{BTU/HR} = \frac{\text{Cubic Feet Per Revolution} \times 3600 \times \text{Heating Value}}{\text{INPUT No. Seconds Per Revolution}}$$

The heating value of your gas can be obtained from your local utility.

For LP/Propane Gas: The only check for the output rate is to properly adjust the manifold pressure using a manometer. Typical manifold setpoint for installations at altitudes from 0 to 4500 feet above sea level is 10.0 inches W.C.

Wiring Diagrams and Sequence of Operation

LRP14HP Unit Wiring Diagram – Constant Torque Blower

DIAGNOSTIC CODES FOR DEFROST CONTROL LEADS

(See instructions or markings on System Diagnostic Module for codes of System Diagnostic Module)

Description	DS1 (GREEN)	DS2 (RED)
No Power to Control	OFF	OFF
Normal Operation / Power to Control	Simultaneous Slow Flash	Alternate Slow Flash
Anti Short Cycle Lockout	OFF	Slow Flash
Low Pressure Switch Fault	OFF	ON
High Pressure Switch Fault	Slow Flash	OFF
High Pressure Switch Lockout	ON	OFF

Note: Because the Pressure Switches are monitored only when "Y1" (input) is active, the code for pressure switch open will not be seen when "Y1" is off. Instead, the "Normal Operation" or "Anti Short Cycle" code will be seen.
Also, when a pressure switch opens and caused a short cycle lockout, the pressure switch-open code will be seen until it closes, then the short cycle lockout code will flash unless it has already expired.

CONNECTION DIAGRAM, HEAT PUMP CONSTANT TORQUE BLOWER, SINGLE PHASE

NOTE: TAP1 FOR FAN ONLY
TAP2 FOR COOLING
TAP3 FOR HIGH STATIC COOLING
TAP4 AND TAP5 FOR ELECTRIC HEAT- REFER TO HEATING LABEL

INDOOR BLOWER MOTOR

W1 & W2 CAN BE USED TO STAGE THE FAN MOTOR TO DISBURT ON 10, 15 & 20KW MODELS
5 & 7, 5KW HEATER ACCESSORIES FUNCTION OFF-W1 ONLY.

NOTE: IF ANY OF THE ORIGINAL WIRE IS REPLACED THE SAME SIZE AND TYPE WIRE MUST BE USED. USE COPPER CONDUCTOR ONLY. MIN 75C WIRE.

J1: PLUG THROUGH CONTROL PANEL (12 PIN)

J2: PLUG FOR ACCESSORY HEAT (6 PIN)

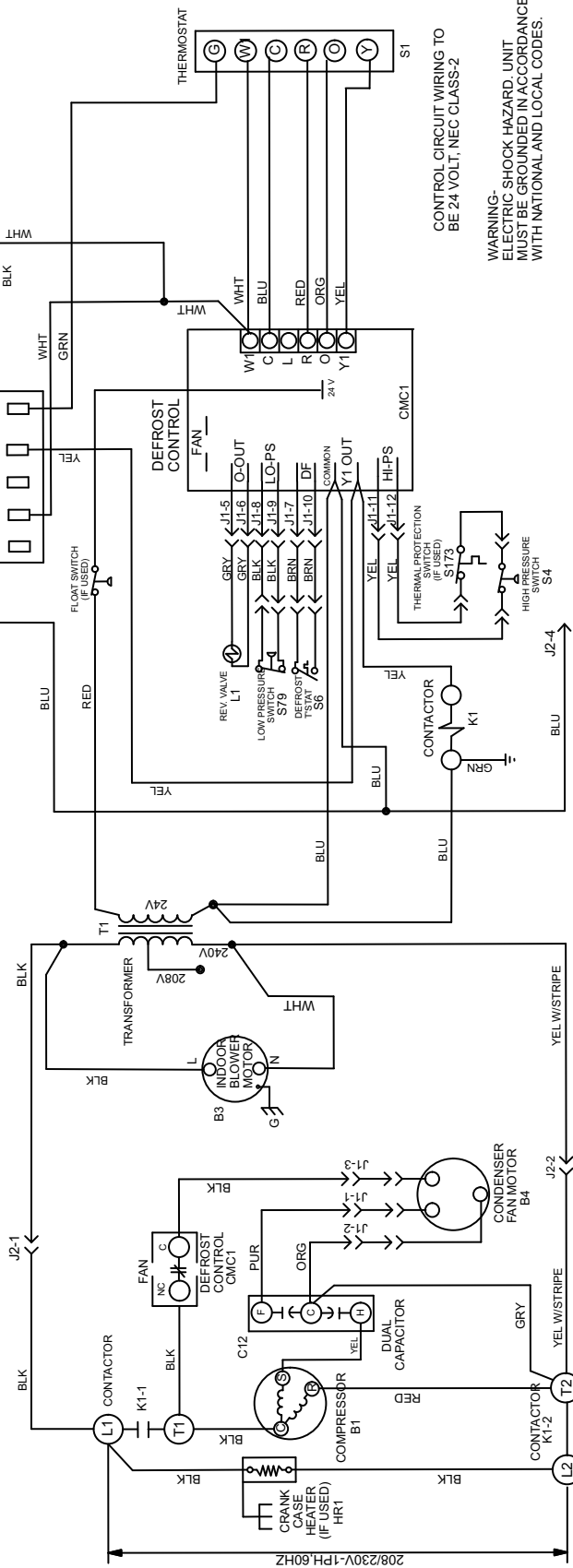

CONTROL CIRCUIT WIRING TO BE 24 VOLT, NEC CLASS-2
WARNING: ELECTRIC SHOCK HAZARD. UNIT MUST BE GROUNDED IN ACCORDANCE WITH NATIONAL AND LOCAL CODES.

LINE VOLTAGE FIELD INSTALLED

FIGURE 17

LRP14HP Unit Wiring Diagram – PSC Blower

BLOWER SPEED CHART	
UNIT	FACTORY SHIPPED SETTINGS
42	(BLK) 3
48	3

CONNECTION DIAGRAM - HEAT PUMP (PSC BLOWER) SINGLE PHASE

W1 & W2 CAN BE USED TO STAGE ELECTRIC HEAT ACCESSORY ON 10.15 & 20KW MODELS
5 & 7.5 KW HEATER ACCESSORIES FUNCTION OFF W1 ONLY.

DIAGNOSTIC CODES FOR DEFROST CONTROL LEADS

(See instructions or markings on System Diagnostic Module for codes of System Diagnostic Module)

Description	DS2 (GREEN)	DS1 (RED)
No Power to Control	OFF	OFF
Normal Operation / Power to Controls	Simultaneous Slow Flash	Simultaneous Slow Flash
Anti-Short Cycle Lockout	OFF	Alternate Slow Flash
Low Pressure Switch Lockout	OFF	Slow Flash
High Pressure Switch Lockout	ON	ON
High Pressure Switch Lockout	OFF	Slow Flash
High Pressure Switch Lockout	ON	OFF

Note: Because the Pressure Switches are monitored only when "Y1" (input) is active, the code for pressure switch open will not be seen when "Y1" is off. Instead, the "Normal Operation" or "Anti Short Cycle" code will be seen.
Also, when a pressure switch opens and caused a short cycle lockout, the pressure switch-open code will be seen until it closes, then the short cycle lockout code will flash unless it has already expired.

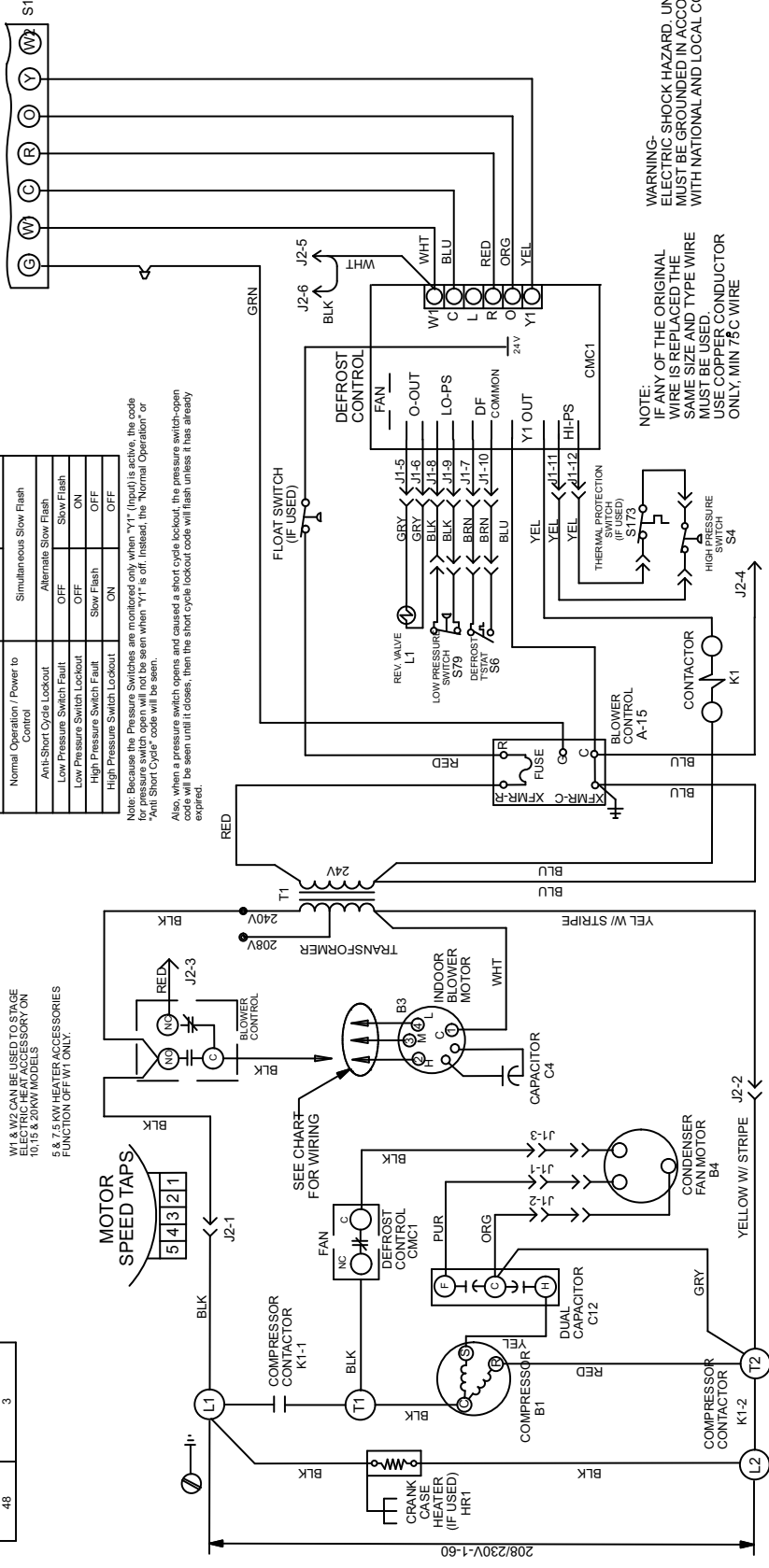

WARNING: IF ANY OF THE ORIGINAL WIRE IS REPLACED THE SAME SIZE AND TYPE WIRE MUST BE USED. USE COPPER CONDUCTOR ONLY, MIN 75C WIRE

J1: PLUG THROUGH CONTROL PANEL (12 PIN)
J2: PLUG FOR ACCESSORY HEAT (6 PIN)

LINE VOLTAGE FIELD INSTALLED

FIGURE 18

LRP14DF Unit Wiring Diagram – Constant Torque Blower

CONNECTION DIAGRAM-DUAL FUEL CONSTANT TORQUE BLOWER - SINGLE PHASE

DIAGNOSTIC CODES FOR DEFROST CONTROLLEDS

(See instructions or markings on System Diagnostic Module for codes of System Diagnostic Module)

Description	DS2 (GREEN)	DS1 (RED)
No Power to Control	OFF	OFF
Normal Operation / Power to Control	Simultaneous Slow Flash	OFF
Anti-Short Cycle Lockout	Alternate Slow Flash	OFF
Low Pressure Switch Fault	OFF	Slow Flash
High Pressure Switch Lockout	OFF	ON
High Pressure Switch Fault	Slow Flash	OFF
High Pressure Switch Lockout	ON	OFF

Note: Because the Pressure Switches are monitored only when "Y1" (pin1) is active, the code will be seen when "Y1" is off. Instead, the "Normal Operation" or "Anti Short Cycle" code will be seen.

Also, when a pressure switch opens and caused a short cycle lockout, the pressure switch open code will be seen until it closes, then the short cycle lockout code will flash unless it has already expired.

DIAGNOSTICS: IGNITION CONTROL codes will indicate normal or abnormal operations.
SLOW FLASH: Normal operation, no call for heat.
FAST FLASH: System lockout, call for heat.
2 FLASH: Pressure switch senses incorrect pressure.
3 FLASH: Flame sensor and gas valve not energized.
5 FLASH: Internal failure (micro-controller failure; self check)
STEADY: Internal failure (micro-controller failure; self check)

HEAT ANTICIPATION GETTING: 0.75 AMP
 CONTROL CIRCUIT WIRING TO
 24 VOLT, NEC CLASS-2

THERMOSTAT

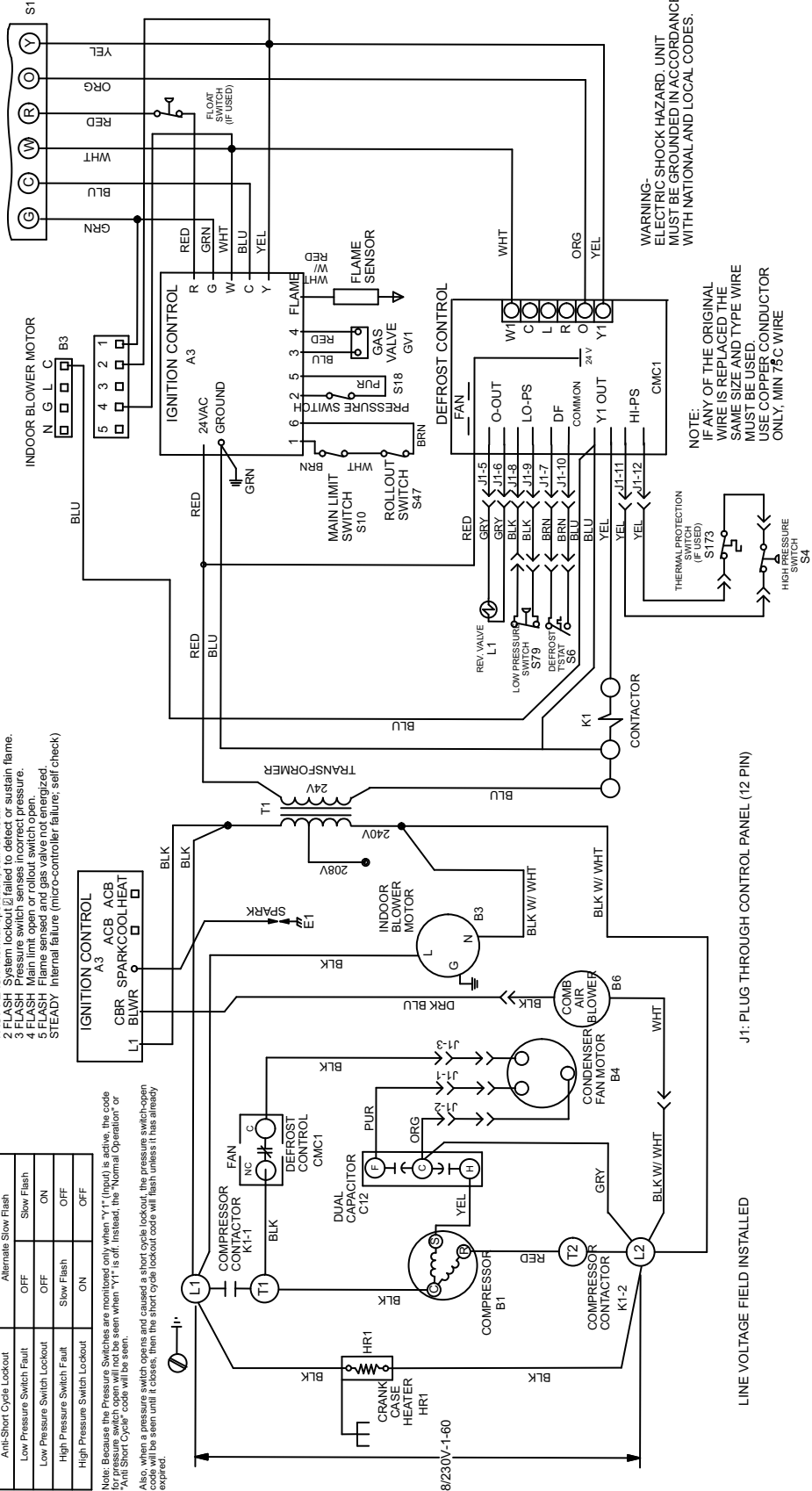

WARNING-
 ELECTRIC SHOCK HAZARD. UNIT
 MUST BE GROUNDED IN ACCORDANCE
 WITH NATIONAL AND LOCAL CODES.

NOTE:
 IF ANY OF THE ORIGINAL
 WIRE IS REPLACED THE
 SAME SIZE AND TYPE WIRE
 MUST BE USED.
 USE COPPER CONDUCTOR
 ONLY, MIN 75C WIRE

NOTE:
 THE COMBUSTION AIR INDUCER IS ENERGIZED FOR 30 SECONDS
 AT A Y1 CALL FOR COOLING TO CLEAR WARM HUMID AIR OUT OF
 THE HEAT EXCHANGER.

J1: PLUG THROUGH CONTROL PANEL (12 PIN)

LINE VOLTAGE FIELD INSTALLED

FIGURE 19

LRP14DF Unit Wiring Diagram – PSC Blower

BLOWER SPEED CHART	
UNIT	INPUT
COOLING/ HEATING	COOL (BLUE W/ STRIPE)
4972	3
4255	3
48126	3

* JUMPER REQUIRED

IF THE JUMPER IS NOT USED, CONNECT RED W/STRIPE WIRE TO THE HEAT TERMINAL.

CONNECTION DIAGRAM- DUAL FUEL (PSC BLOWER) SINGLE PHASE

DIAGNOSTICS 2 IGNITION CONTROL codes will indicate normal or abnormal operations:
 SLOW FLASH Normal operation, no call for heat.
 FAST FLASH Normal operation, call for heat.
 3 FLASH System lockout 2 failed to detect or sustain flame.
 4 FLASH Pressure switch senses incorrect pressure.
 5 FLASH Flame sensed and gas valve not energized.
 STEADY Internal failure (micro-controller failure; self check)

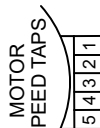

DIAGNOSTIC CODES FOR DEFROST CONTROL LEADS

(See instructions or markings on System Diagnostic Module for codes of System Diagnostic Module)

Description	DS2 (GREEN)	DS1 (RED)
No Power to Control	OFF	OFF
Normal Operation / Power to Control	Simultaneous Slow Flash	Alternate Slow Flash
Anti-Short Cycle Lockout	OFF	Slow Flash
Low Pressure Switch Fault	OFF	ON
High Pressure Switch Lockout	Slow Flash	OFF
High Pressure Switch Lockout	ON	OFF

Note: Because the Pressure Switches are monitored only when "Y1" (input) is active, the code for pressure switch open will not be seen when "Y1" is off. Instead, the "Normal Operation" or "Anti Short Cycle" code will be seen.
 Also, when a pressure switch opens and causes a short cycle lockout, the pressure switch-open code will be seen until it closes, then the short cycle lockout code will flash unless it has already expired.

HEAT ANTICIPATION SETTING 0.75 AMP
 CONTROL CIRCUIT WIRING TO 24 VOLT, NEC CLASS-2

THERMOSTAT

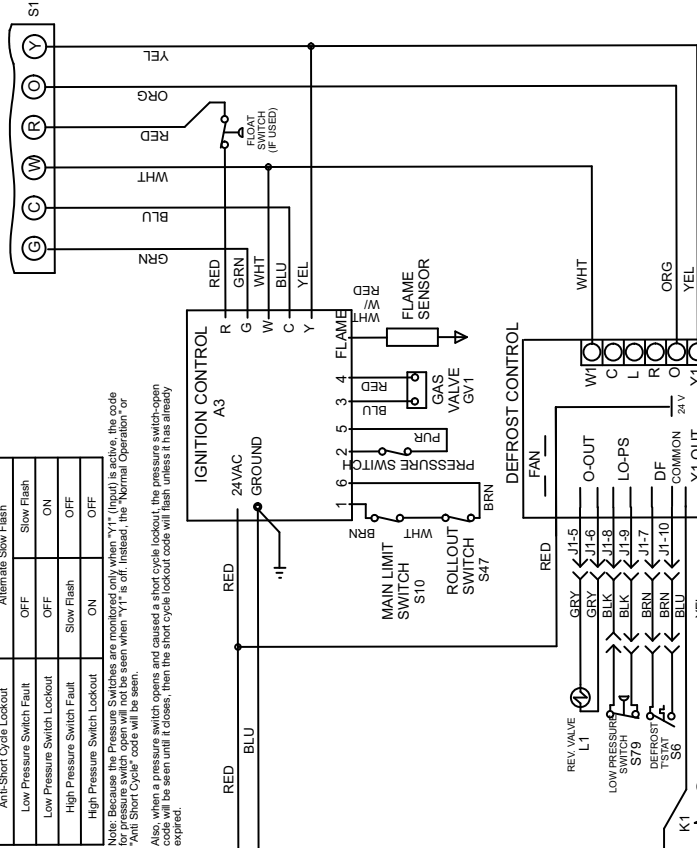

WARNING- ELECTRIC SHOCK HAZARD. UNIT MUST BE GROUNDED IN ACCORDANCE WITH NATIONAL AND LOCAL CODES.

NOTE: IF ANY OF THE ORIGINAL WIRE IS REPLACED THE SAME SIZE AND TYPE WIRE MUST BE USED. USE COPPER CONDUCTOR ONLY, MIN 75°C WIRE

NOTE:

THE COMBUSTION AIR INDUCER IS ENERGIZED FOR 30 SECONDS AT A Y1 CALL FOR COOLING TO CLEAR WARM HUMID AIR OUT OF THE HEAT EXCHANGER.

FIGURE 20

LRP14AC Unit Wiring Diagram – Constant Torque Blower

CONNECTION DIAGRAM A/C (CONSTANT TORQUE BLOWER) SINGLE PHASE

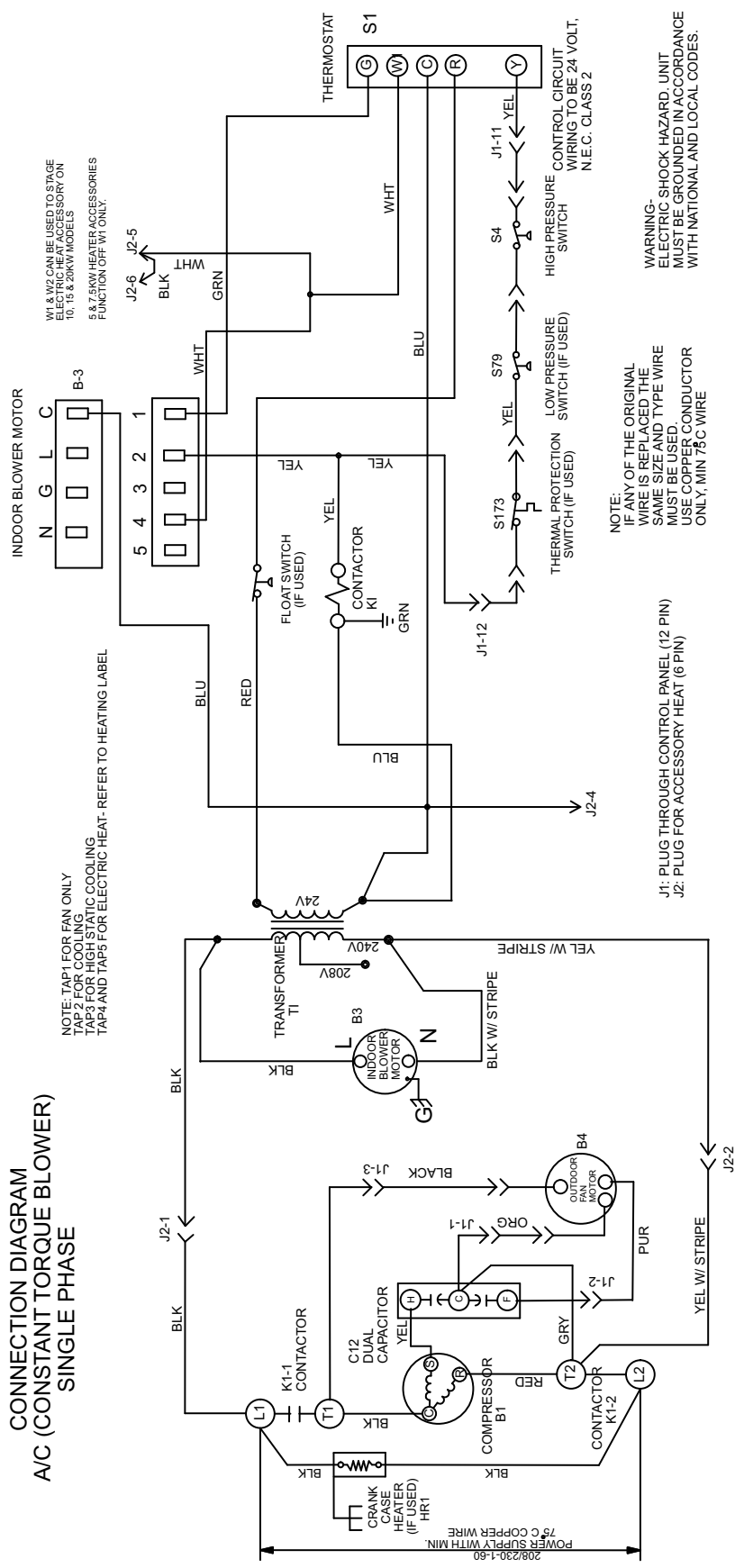

FIGURE 21

LRP14AC Unit Wiring Diagram – PSC Blower

BLOWER SPEED CHART	
UNIT	FACTORY SHIPPED SETTINGS
COOLING INPUT	(BLK)
24	5
30	3
36	3
42	3
48	3



CONNECTION DIAGRAM A/C (PSC BLOWER) SINGLE PHASE

CONTROL CIRCUIT WIRING TO BE 24 VOLT, N.E.C. CLASS 2 THERMOSTAT

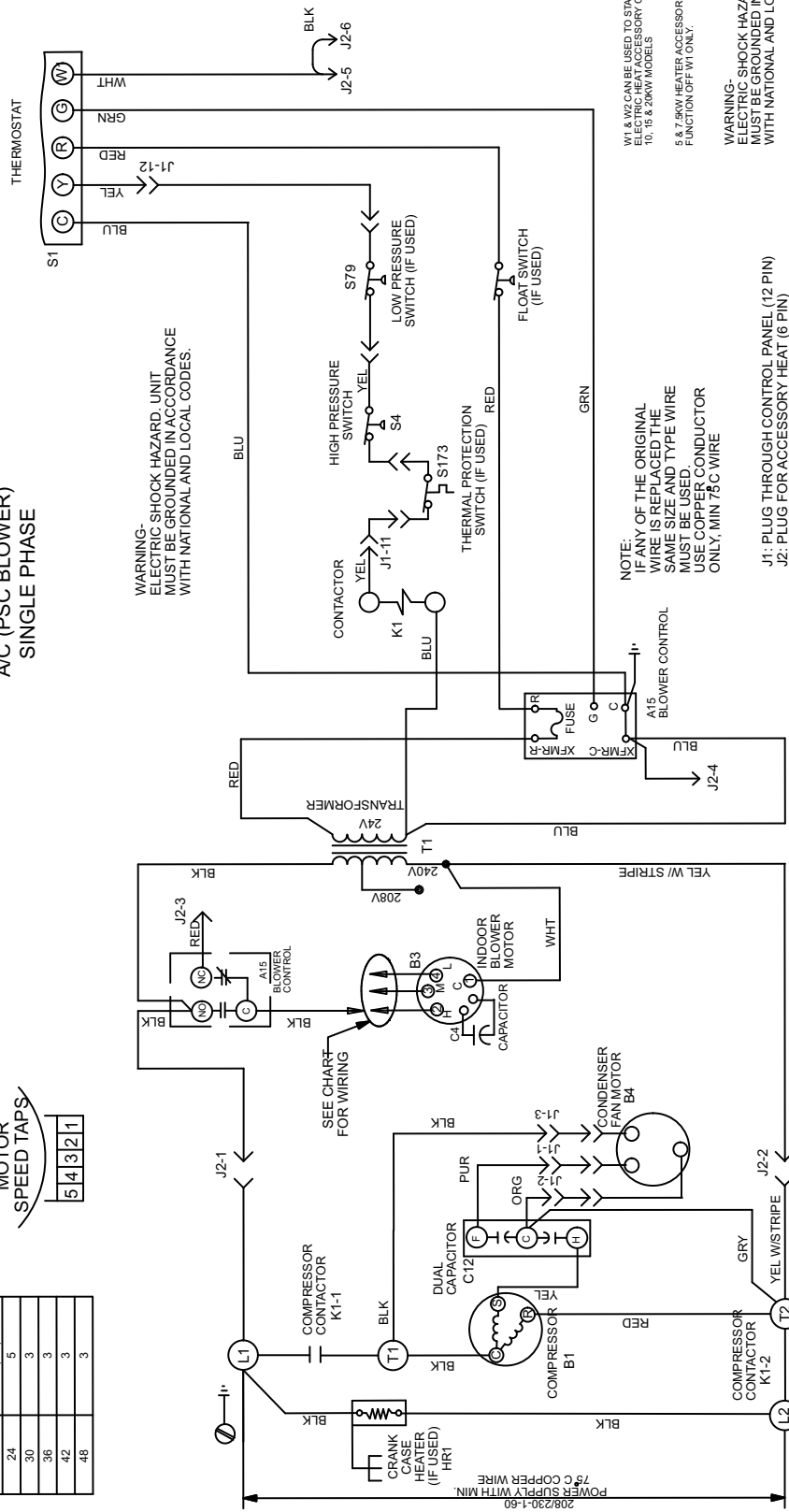

WARNING- ELECTRIC SHOCK HAZARD. UNIT MUST BE GROUNDED IN ACCORDANCE WITH NATIONAL AND LOCAL CODES.

W1 & W2 CAN BE USED TO STAGE ELECTRIC HEAT ACCESSORY ON 10, 15 & 20KWT MODELS
S & T 50KVA HEATER ACCESSORIES FUNCTION OFF W1 ONLY

WARNING- ELECTRIC SHOCK HAZARD. UNIT MUST BE GROUNDED IN ACCORDANCE WITH NATIONAL AND LOCAL CODES.

NOTE: IF ANY OF THE ORIGINAL WIRE IS REPLACED THE SAME SIZE AND TYPE WIRE MUST BE USED. USE COPPER CONDUCTOR ONLY, MIN 75°C WIRE

J1: PLUG THROUGH CONTROL PANEL (12 PIN)
J2: PLUG FOR ACCESSORY HEAT (6 PIN)

LINE VOLTAGE FIELD INSTALLED

FIGURE 22

LRP14GE Unit Wiring Diagram – Constant Torque Blower

CONNECTION DIAGRAM GAS/ELECTRIC (CONSTANT TORQUE BLOWER) SINGLE PHASE

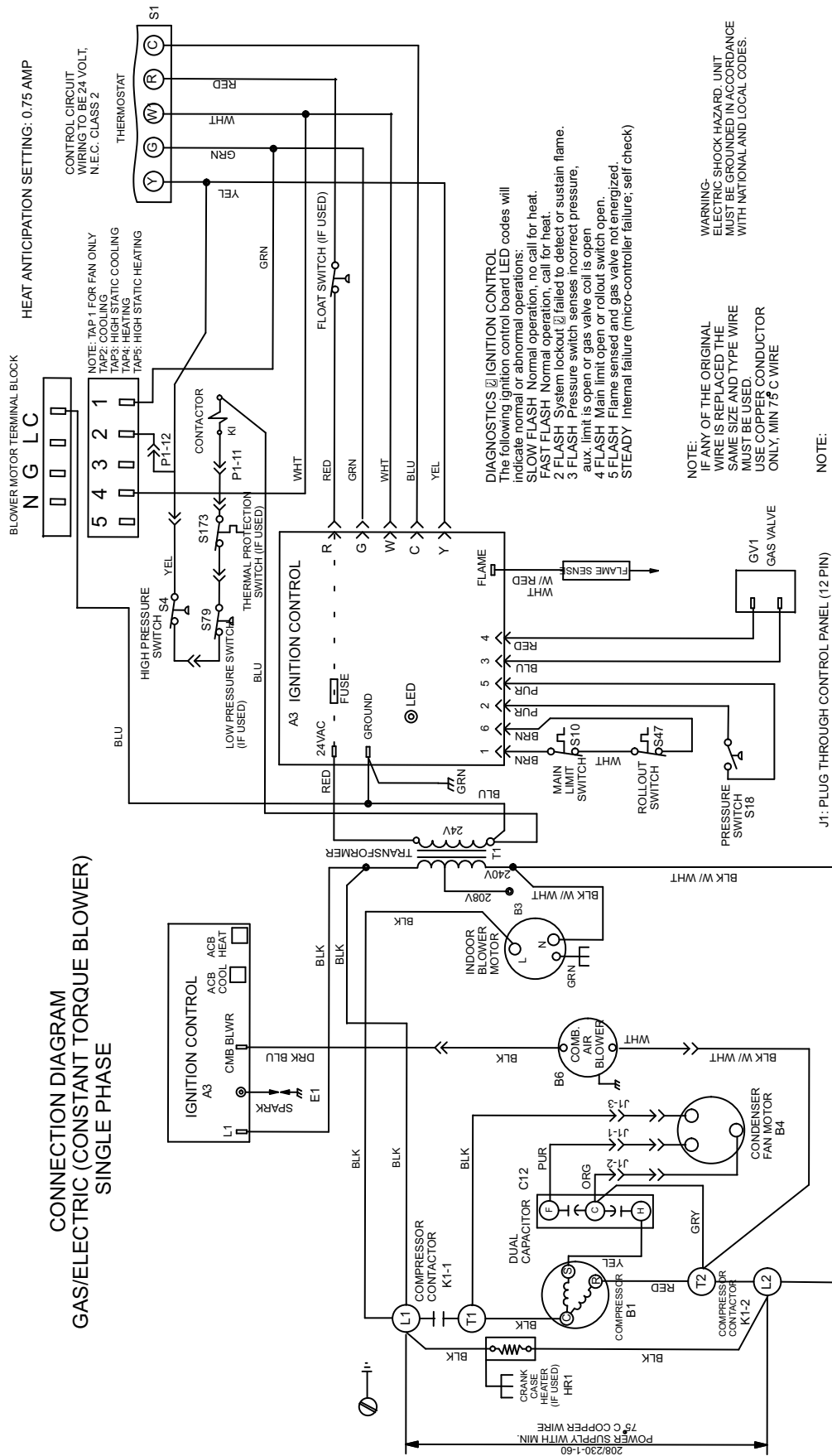

FIGURE 23

LRP14GE Unit Wiring Diagram – PSC Blower

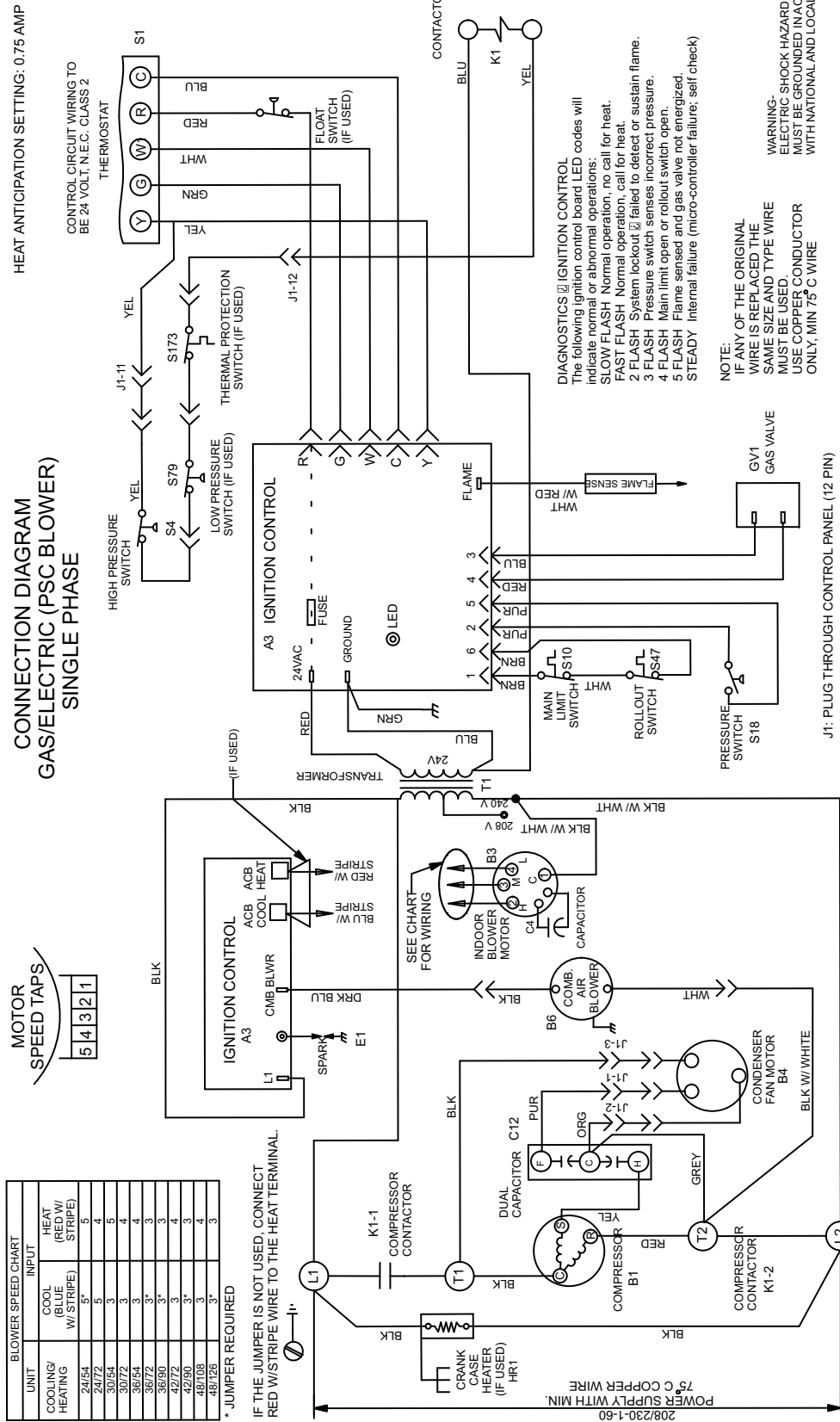
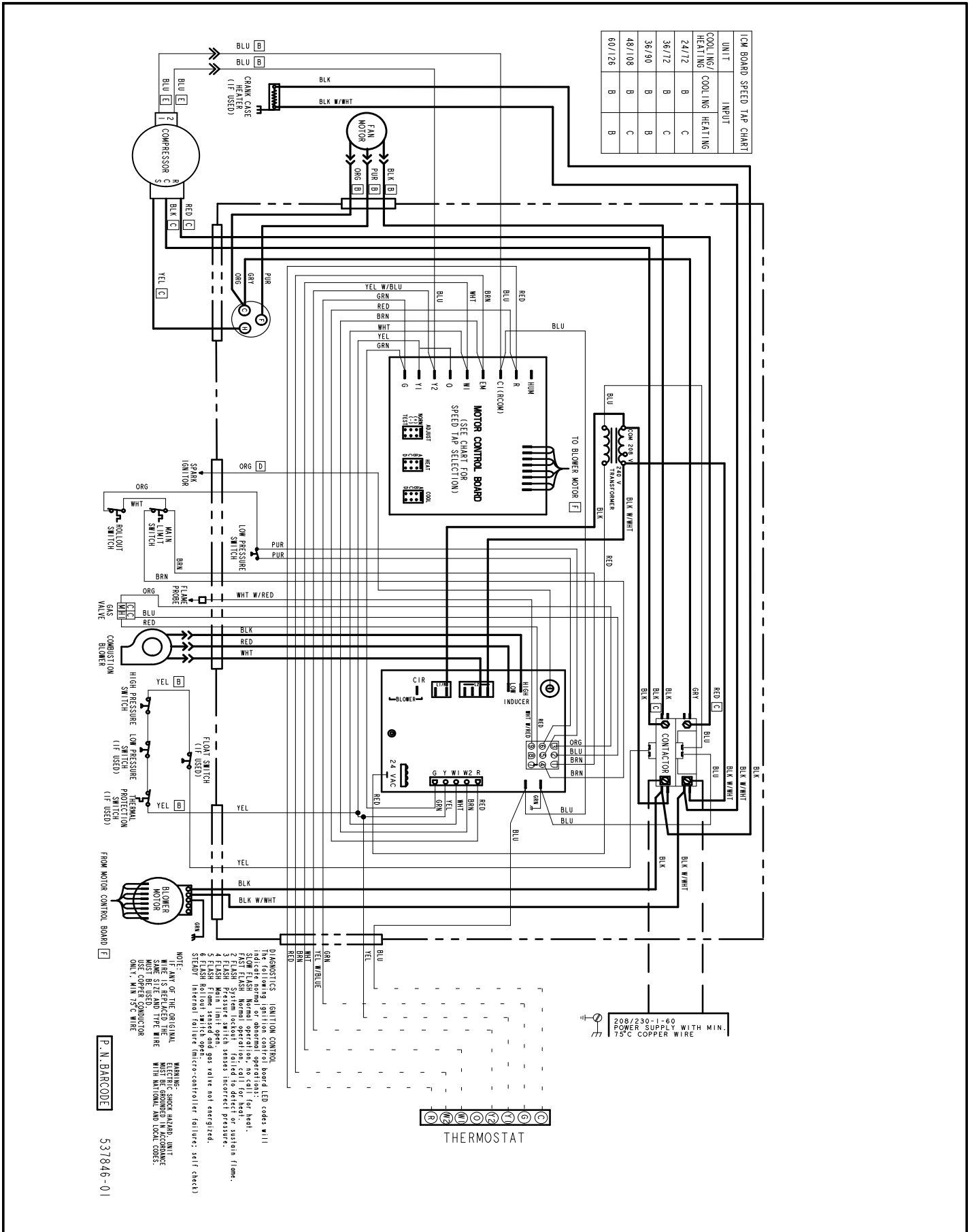

FIGURE 24

LRP16GE Wiring Diagram



UNIT	INPUT
COOLING/ HEATING	COOLING HEATING
24/72	B C
36/72	B C
36/90	B B
48/108	B C
60/126	B B

DIAGNOSTICS (IGNITION CONTROL)
 The following ignition control board (ICB) codes will indicate normal or abnormal operations:
 1. FLASH Normal operation, coil or best.
 2. FLASH Normal operation, coil or best.
 3. FLASH System lockout, failed to detect or sustain flame.
 4. FLASH Pressure switch senses incorrect pressure.
 5. FLASH Flame sensed and gas valve not energized.
 6. FLASH Rollout switch opens.
 7. FLASH Internal failure (micro-controller failure; self check)

NOTE: ANY OF THE ORIGINAL WARNING: ELECTRIC SHOCK HAZARD. UNIT MUST BE USED. SAME SIZE AND TYPE WIRE WITH NATIONAL AND LOCAL CODES. ONLY, WITH 75°C WIRE.

P-N BARCODE 537846-01

THERMOSTAT

FIGURE 25

LRP16GE Unit Wiring – Single Phase

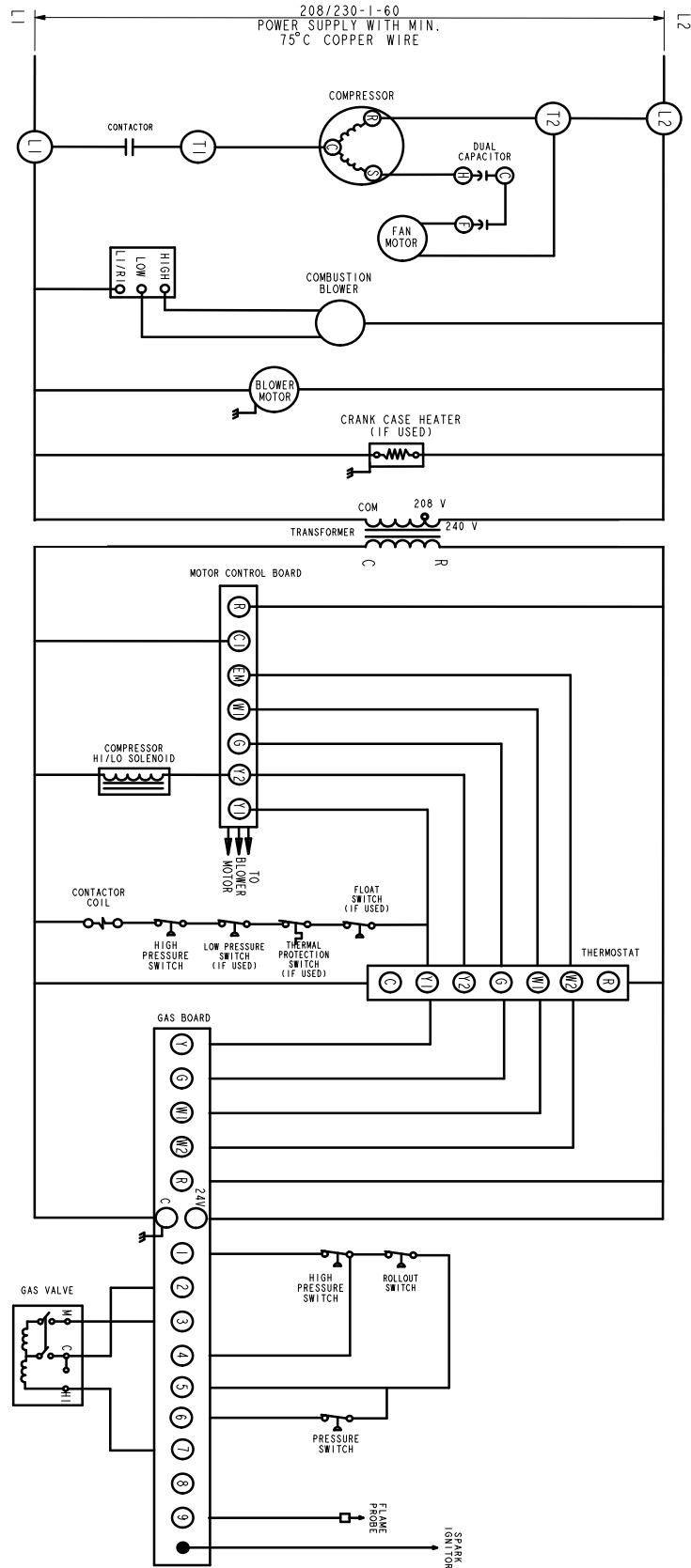

FIGURE 26

LRP16HP Wiring Diagram

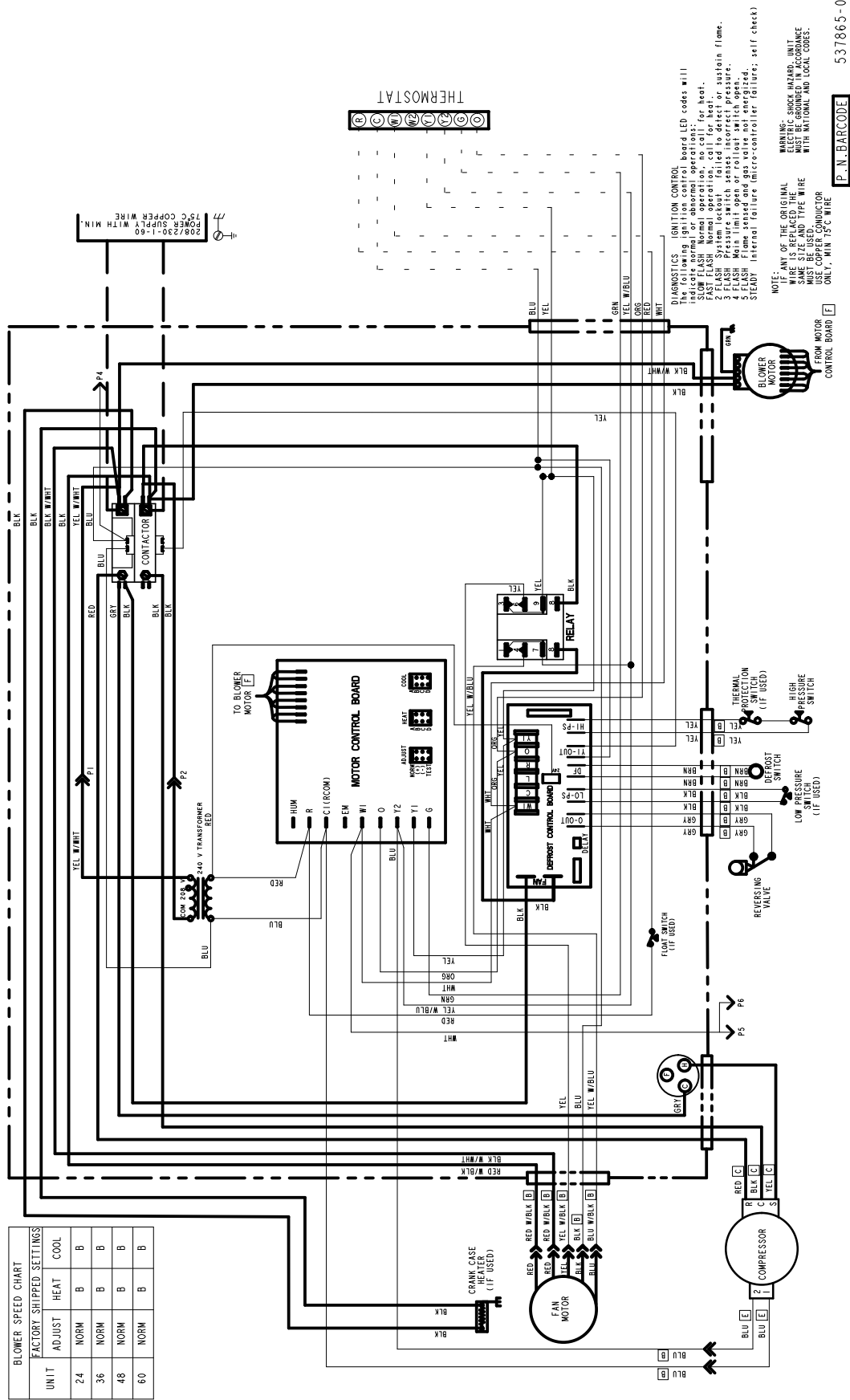

FIGURE 27

LRP16HP Unit Wiring – Single Phase

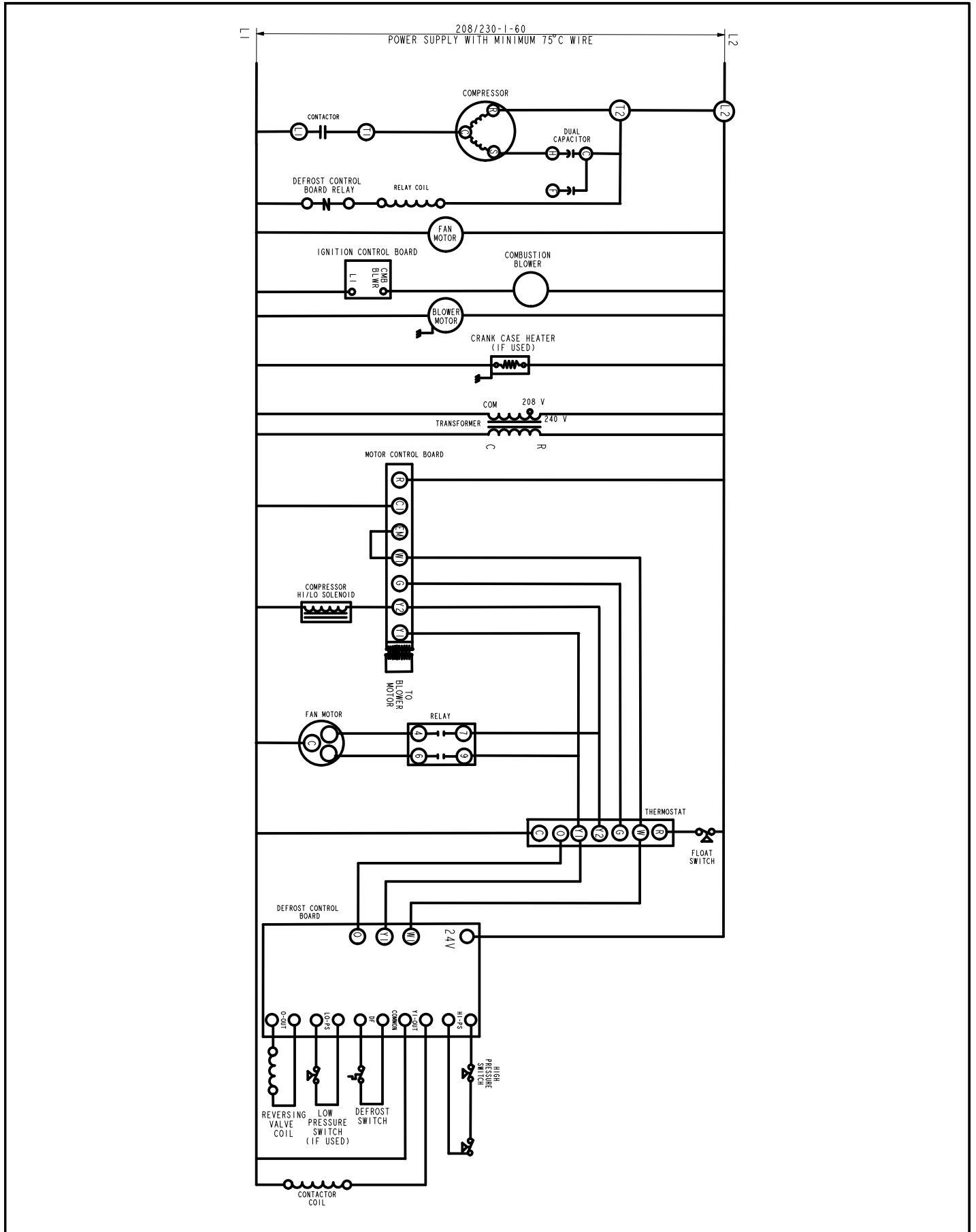

FIGURE 28

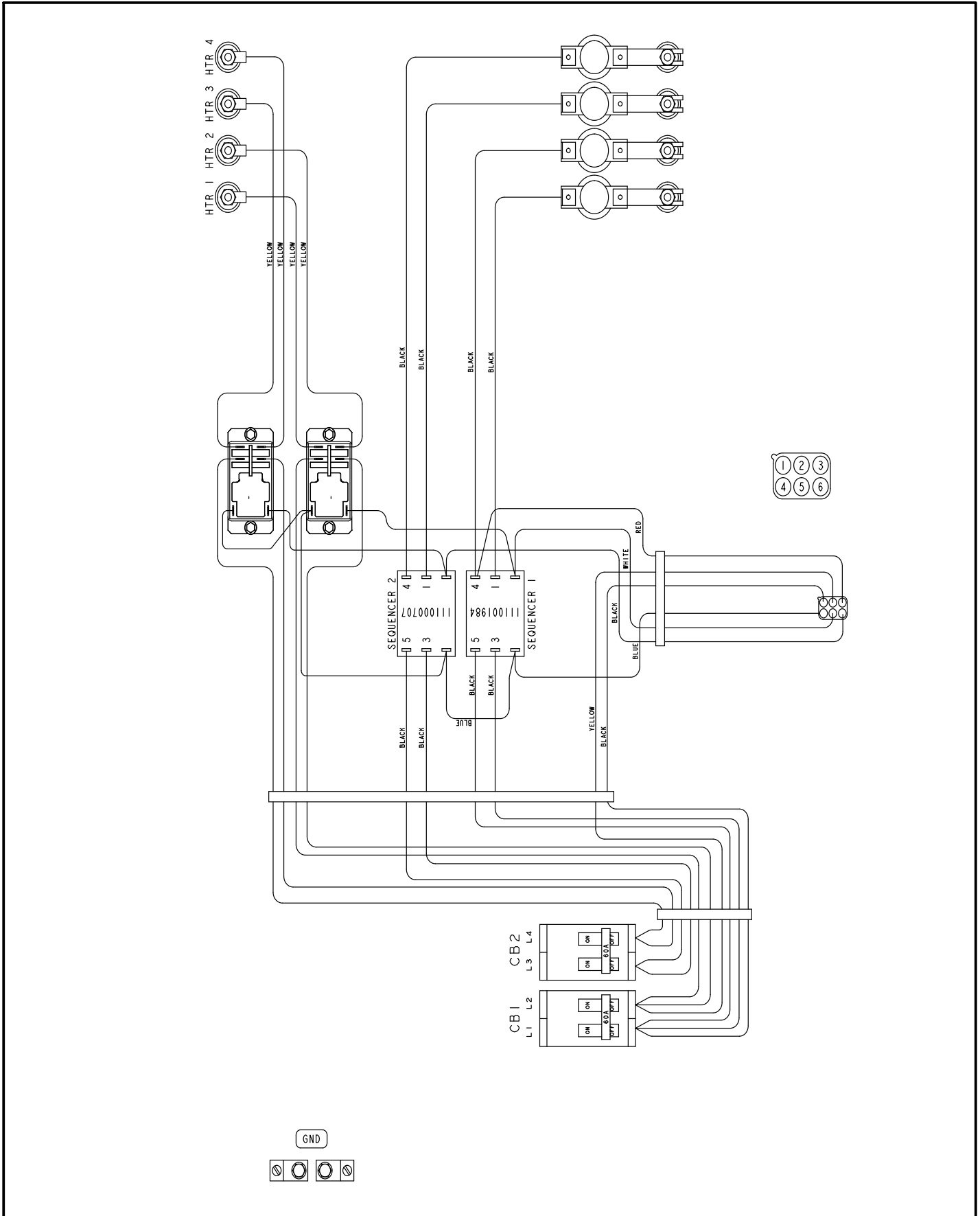
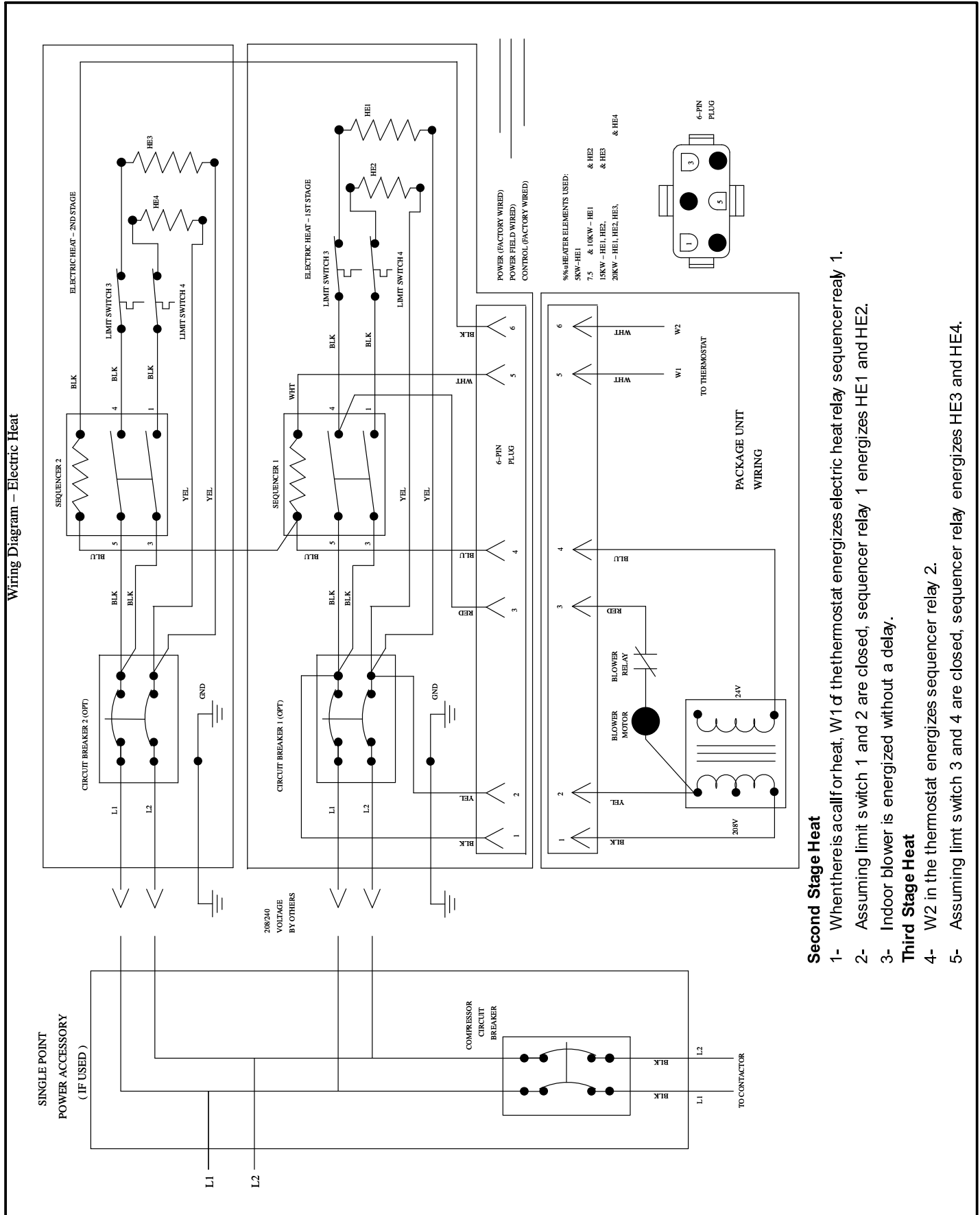

FIGURE 29

B-PHK Electric Heat – Older Models



Second Stage Heat

- 1- When there is a call for heat, W1 of the thermostat energizes electric heat relay sequencer relay 1.
- 2- Assuming limit switch 1 and 2 are closed, sequencer relay 1 energizes HE1 and HE2.
- 3- Indoor blower is energized without a delay.

Third Stage Heat

- 4- W2 in the thermostat energizes sequencer relay 2.
- 5- Assuming limit switch 3 and 4 are closed, sequencer relay energizes HE3 and HE4.

FIGURE 30

SEQUENCE OF OPERATION – SINGLE-STAGE COMPRESSOR

NOTE - The combustion air inducer is energized for 30 seconds at a Y1 call for cooling to clear warm humid air out of the heat exchanger.

Cooling

- 1- Internal thermostat wiring energizes terminal "O" by cooling mode selection, energizing reversing valve L1.
- 2- Cooling demand initiates at Y1 in the indoor thermostat.
- 3- 24VAC from Y1 energizes compressor contactor K1.
- 4- K1-1 closes energizing compressor B1 and outdoor fan motor B4.
- 5- Compressor B1 and outdoor fan B4 begin immediate operation.
- 6- Evaporator blower B3 begins operation.
- 7- When cool demand is satisfied, "Y1" in the indoor thermostat de-energizes K1 contactor. K1-1 opens de-energizing compressor B1 and outdoor fan B4. Evaporator blower B3 de-energizes after 90 seconds of time delay.
- 8- Terminal "O" is de-energized when internal thermostat is out of cool mode, de-energizing reversing valve L1.

First Stage Heat Pump

- 1- Heating demand initiates at "Y1" in the thermostat.
- 2- 24VAC energizes compressor contactor K1.
- 3- K1-1 closes energizing compressor B1 and outdoor fan B4.
- 4- Evaporator blower B3 energizes after 5 seconds.
- 5- When heat demand is satisfied, Y1 in the indoor thermostat de-energizes K1. K1-1 and K1-2 open and de-energizes compressor B1 and outdoor fan B4.
- 6- Evaporator blower B3 de-energizes after 90 seconds.

Second Stage Auxiliary Heat

- 1- Heating demand initiates at "Y1" and "W" in the thermostat. "W" can either be strip heat in a HP unit or gas burners in a DF unit.

Emergency Heat

- 1- Emergency heat is energized by the room thermostat through "W".

Defrost Mode

- 1- During heating operation when liquid line temperature drops to 42°F or lower defrost switch S6 closes.
- 2- Defrost control CMC1 begins timing. If defrost thermostat S6 remains closed at the end of 30, 60 or 90 minute period, defrost control energizes and defrost begins

NOTE - On early defrost controls, the defrost timing jumper must be in the 90-minute defrost interval before testing the defrost mode or the control will not enter defrost test mode.

- 3- During defrost CMC1 energizes the reversing valve L1 and de-energizes the outdoor fan B4. If the compressor delay jumper is set, the compressor will turn off for 30 seconds while the reversing valve shifts either in or out of defrost mode.
- 4- Defrost continues for 10 minutes or until defrost thermostat switch S6 opens (S6 will open when liquid line temperature reaches 70°). When defrost thermostat switch opens, defrost control CMC1 loses power and resets.
- 5- When CMC1 resets, reversing valve L1 is de-energized while outdoor fan B4 is energized.

Gas Heat

- 1- Heating demand W1 initiates at the indoor thermostat.
- 2- Assuming all safety circuits are closed (with the exception of the pressure-prove switch open), A3 energizes the combustion air inducer blower B6. When the N.O. combustion air inducer pressure-prove switch S18 closes, a pre-purge period of 30 seconds follows.
- 3- Ignition control A3 begins spark and energizes gas valve GV1.
- 4- Gas valve GV1 opens. When flame is sensed, spark stops.
- 5- After 30 seconds, ignition control A3 energizes circulating air blower B3.
- 6- When heat demand is satisfied, the indoor thermostat de-energizes control A3 which de-energizes gas valve GV1 and combustion air inducer blower B6. Circulating air blower B3 runs for a designated period of 90 seconds.

SEQUENCE OF OPERATION – TWO-STAGE COMPRESSOR

The two-stage scroll compressor operates much like the standard scroll compressor. The two-stage compressor steps between low capacity and high capacity as required to meet cooling demand. The steps occur when gas is bypassed through a vent port in the first suction pocket. This bypassing of gas allows the compressor to operate at low capacity if thermostat demand allows, creating a more cost effective and efficient compressor. Full capacity is achieved by blocking the vent port with a slider ring. The slider ring (vent port cover) is controlled by a 24VDC internal solenoid in the open position allowing low capacity. When energized the internal solenoid closes the slider ring, blocking the vent port and bringing the compressor to full capacity.

Stepping can occur during a single thermostat demand as the motor runs continuously while the compressor steps from low to full capacity.

First and second stage cooling operate independent of each other and can modulate back and forth according to the thermostat demand.

First Stage Cooling (Low Capacity)

1. Cooling demand initiates at Y1 at the thermostat.
2. Voltage from terminal Y passes through S4 high pressure switch, energizes K1 compressor contactor, passes through the low pressure switch (S87) and returns to common side of the 24VAC power.
3. K1 closes, energizing B1 compressor and B4 outdoor fan.
4. Solenoid L34 is not energized so the slider ring remains open, limiting compressor to low capacity.

Second Stage Cooling (High Capacity)

Compressor is operating in first stage cooling. Second stage thermostat demand sends voltage to rectifier plug D4. D4 converts the AC voltage to DC voltage and energizes L34 unloader solenoid. L34 closes the slider ring, allowing the compressor to operate at high capacity.