

INSTALLATION INSTRUCTIONS

Dwyer Fixed Length & Averaging Duct Temperature Sensors Packaged Ventilation/Dedicated Outside Air System (DOAS) model DLV

Fixed Length and Averaging Sensors

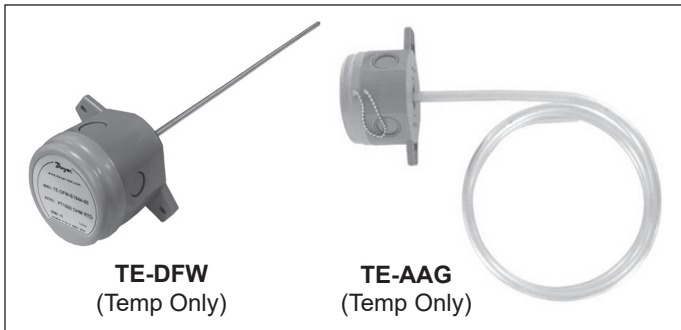

⚠ WARNING

1. Disconnect power supply before making wiring connections to prevent electrical shock and equipment damage.
2. All units must be wired strictly in accordance with wiring diagram furnished with the unit. Any wiring different from the wiring diagram could result in a hazard to persons and property.
3. All wiring must be done with a wiring material having a temperature rating of at least 105°C.

⚠ CAUTION

As with any mechanical equipment, personal injury can result from contact with sharp sheet metal edges. Be careful when you handle this equipment.

IMPORTANT

1. The use of this manual is specifically intended for a qualified installation and service agency. All installation and service of these kits must be performed by a qualified installation and service agency.
2. These instructions must also be used in conjunction with the Installation and Service Manual originally shipped with the unit, in addition to any other accompanying component supplier literature.

Application

The Dwyer temperature sensors are used in conjunction with the Carel controller used on all model "DLV" Packaged Ventilation/Dedicated Outside Air System (DOAS) Units. The sensors are used as supply air sensors and are to be field installed in the supply air ductwork.

The sensors ship loose with a packing slip identifying the part numbers as shown in Table 1.1.

Table 1.1 - Supply Air Sensors

Item Code	Dwyer Part Number	Sensor Length	Sensor Type
40329	TE-DFW-E18x4-00	18" Fixed	Temp Only
40330	TE-AAG-E0634-00	6' Averaging	
40331	TE-AAG-E1234-00	12' Averaging	

Dwyer Fixed/Adjustable Length Duct Sensor Installation

Sensor Installation Location

Location of the sensor is very important for proper control. Where possible:

- The sensor should be located between 8 and 20 feet downstream from the unit discharge connection.
- The sensor should be mounted in a single perimeter duct as shown in Figure 2.1. If the ductwork is split, the sensor should be mounted before the split is made. Locating sensors in a branch duct as shown in Figure 2.2 may cause poor temperature control.
- Avoid placing the sensor near turns in the ductwork.
- For the Fixed Length Probe Sensor, the sensor should be mounted in a position following Figure 2.1 and Table 2.1.
- For the Adjustable Length Averaging Sensor, the sensor should be mounted so it spans the width of the duct, from side to side of the duct.

Figure 2.1 – Duct Sensor Installation Locations

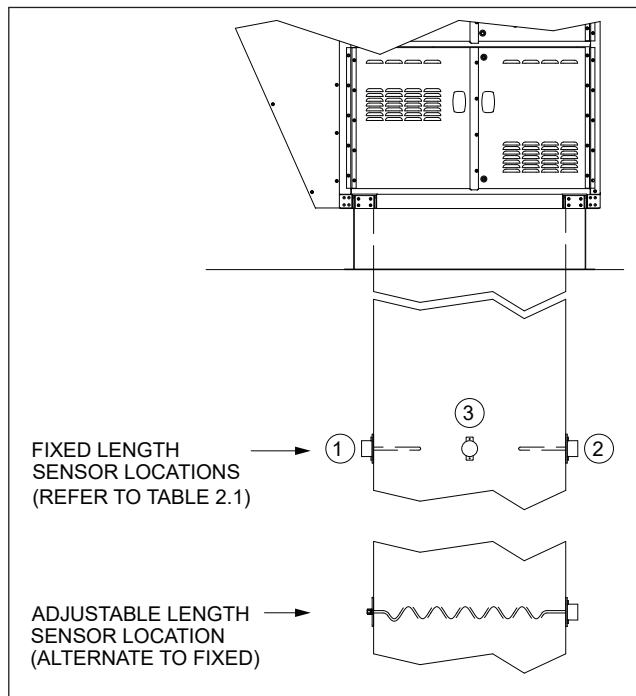
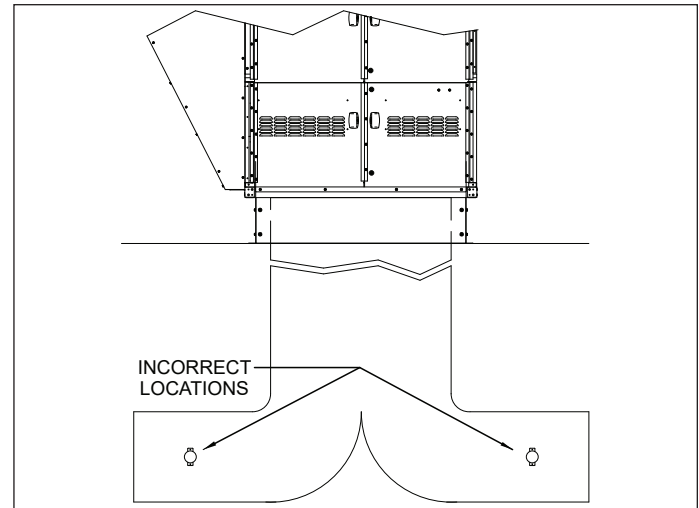

Table 2.1 – Preferred Mounting Locations for Fixed Length Supply Air Sensor

Unit Cabinet Size	Preferred Location
B-Cabinet	1, 2, or 3
C-Cabinet	1 or 2
D-Cabinet	

Figure 2.2 - Incorrect Split Duct Sensor Locations



Sensor Installation - Fixed Length Probes

Once the location of installation on the ductwork is determined from the previous section, install the sensor as follows:

1. Verify the sensor being installed is the correct sensor.
2. Drill a 1/2" hole in the duct for the probe to be inserted.
3. Slide the sensor through the hole in the duct and mark where pilot holes are required to secure the sensor mounting tabs to the duct. Remove the sensor and drill 1/8" pilot holes.
4. Verify the gasket that came with the sensor is secured on the back of the sensor junction box. Slide the sensor back into place and secure with the screws included.

Figure 2.3 - Drill Locations for Sensor Mounting

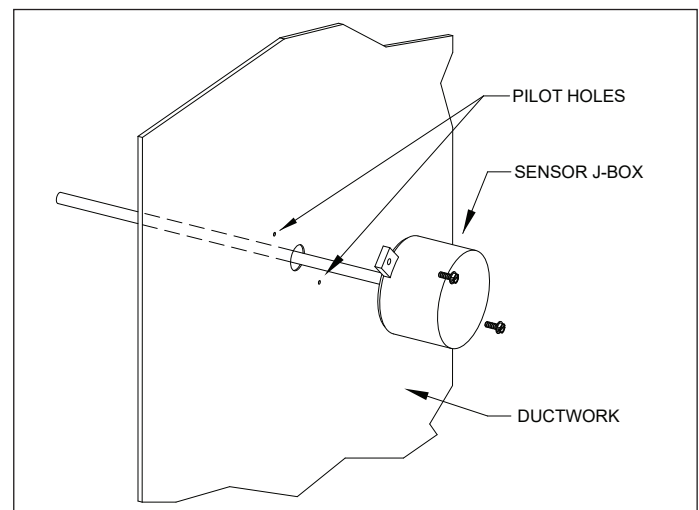

Dwyer Fixed/Adjustable Length Duct Sensor Installation

Sensor Installation - Adjustable Length

Once the location of installation on the supply air ductwork is determined from the "Sensor Installation Location" section, install the sensor as follows:

1. For all adjustable length averaging sensors, use the Sensor Mounting Plate included with the kit (see Figure 3.1) as a template to mark where to drill the required holes in the mounting location of the duct. Do not drill through the Sensor Mounting Plate, only use it for marking the ductwork. For the sensor hole in the center location, drill a hole between 1" and 4" in diameter. The end of the sensor needs to be mounted on the opposite side of the duct, so a larger hole will help with maneuvering the sensor during installation.

Figure 3.1 - Sensor Mounting Plate Drill Locations

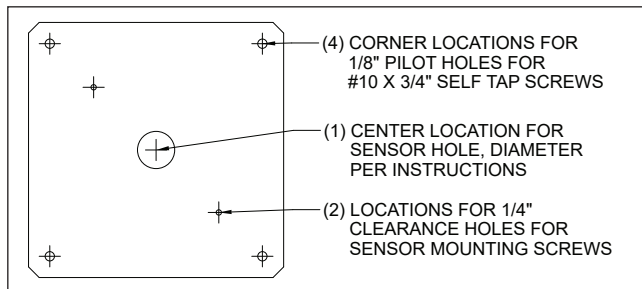

2. In the same location on the opposite side of the duct (directly across from where the holes were drilled in Step 1), repeat Step 1 for the (4) corner holes and the center location sensor hole. The (2) 1/4" clearance holes are not required. The center sensor hole should be between 1" and 4" in diameter as noted in Step 1.
3. The sensor length may need to be adjusted before installation in the duct. Measure the outside width dimension of the duct, across where the sensor will be installed, as shown in Figure 3.2.

Figure 3.2 - Adjustable Length Sensor Dimension

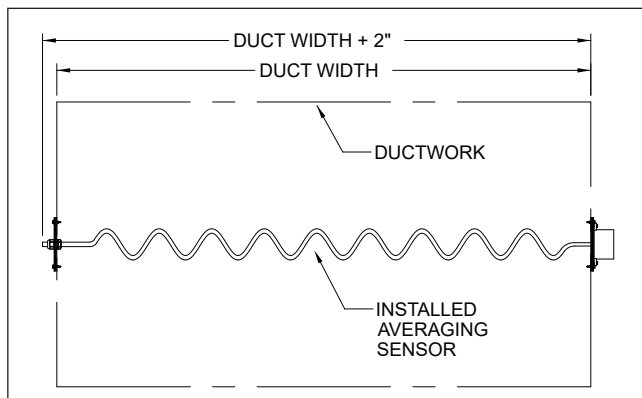

4. The sensor should be approximately 2" longer than the outside dimension of the duct, as shown in Figure 3.2. To adjust the sensor length, follow these steps:
 - a. The aluminum sensor element tube is coiled when it ships. Straighten the sensor and measure the length.
 - b. If the sensor needs to be shortened, the best way is to coil the tubing around a pipe, such as a 1-1/2" PVC pipe as shown in Figure 3.3. Like a spring, the coiled sensor tubing can be stretched or compressed to get the desired length.

Figure 3.3 - Adjusting Length of Sensor Tubing

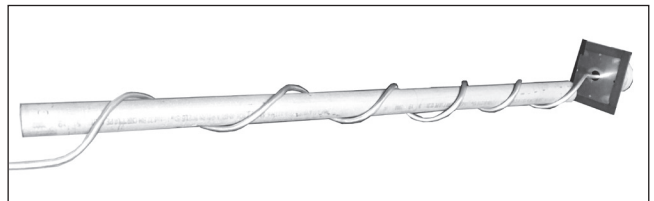

4. Verify the gasket that came with the sensor is secured on the back of the sensor junction box. Slide the sensor through the center hole on the Sensor Mounting Plate and secure with (2) #10 x 1/2" hex head screws included with the kit assembly as shown in Figure 3.4. Be sure that the gasket on the Sensor Mounting Plate is on the opposite side from the sensor junction box.

**Figure 3.4
Sensor to Sensor Mounting Bracket Installation**

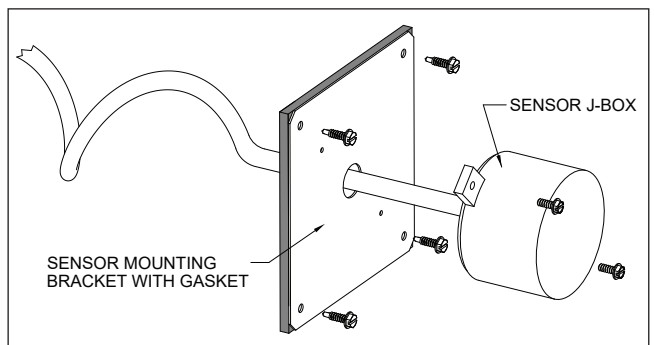

5. Slide the sensor element into the center hole drilled in the duct. Do not secure yet.
6. Carefully maneuver the sensor assembly to extend the end of the sensor through the hole on the opposite side of the duct. This may be easier with a second person located on the opposite side of the duct. Once the end of the sensor is through the hole in the duct, secure the Sensor Mounting Plate on the sensor junction box side to the duct with the (4) #10 x 3/4" self-tapping screws included with the kit.

(continued next page)

Dwyer Fixed/Adjustable Length Duct Sensor Installation

(continued from previous page)

7. On the opposite side, slide the main body of the strain relief bushing over the sensor tubing as shown in Figure 4.1.
8. Slide the Sensor Mounting Plate over the end of the sensor tube and slide the bushing through the center hole of the Sensor Mounting Plate. Loosely thread on the strain relief bushing nut but do not tighten. Slide the Sensor Mounting Plate so that it is securely against the duct. If it does not slide, the bushing nut is likely threaded on too tightly.
 - a. Once the Sensor Mounting Plate is securely against the duct, secure the plate using the (4) #10 x 3/4" self-tapping screws included with the kit.
 - b. Hand tighten the strain relief bushing nut.

Figure 4.1 - Adjustable Sensor End Support

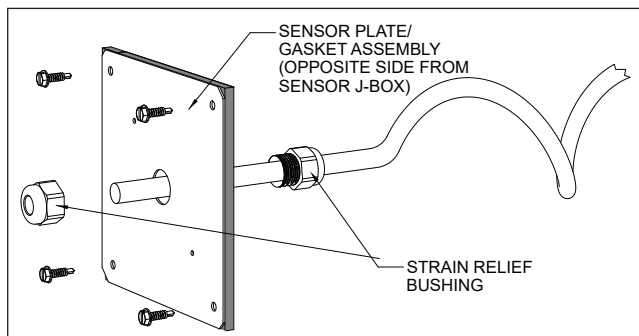

Wiring to the Main Unit Carel Controller

For wiring of the sensor, refer to the following instructions:

1. Remove the cover of the sensor junction box by rotating the cover counterclockwise. Refer to Figure 4.2.
2. Remove the bottom knockout on the junction box. Install the wiring strain relief bushing included in the kit.
3. Connect the two red wires from the sensor to the terminal blocks included in the junction box.
4. Route the control wire (minimum 24AWG twisted pair shielded cable) between the sensor and the controller through the bushing and wire to the terminal block in the junction box per the wiring diagram on the unit.
5. Reinstall the sensor junction box cover, rotating it clockwise.
6. Wire the control wiring to the main unit controller per the wiring diagram on the unit.

Figure 4.2 - Sensor Junction Box Wiring



Duct Sensor Resistance Values

The Dwyer fixed and adjustable length sensors all include temperature sensing. See Table 4.1 for the resistance values at various temperatures.

Table 4.1 - Sensor Resistance vs. Temperature

°F	Ω	°F	Ω	°F	Ω
0	930.3	42	1021.7	84	1112.4
2	934.7	44	1026.0	86	1116.7
4	939.0	46	1030.4	88	1121.0
6	943.4	48	1034.7	90	1125.3
8	947.8	50	1039.0	92	1129.6
10	952.1	52	1043.3	94	1133.9
12	956.5	54	1047.7	96	1138.2
14	960.8	56	1052.0	98	1142.5
16	965.2	58	1056.3	100	1146.8
18	969.5	60	1060.6	102	1151.1
20	973.9	62	1065.0	104	1155.4
22	978.3	64	1069.3	106	1159.7
24	982.6	66	1073.6	108	1164.0
26	986.9	68	1077.9	110	1168.3
28	991.3	70	1082.2	112	1172.6
30	995.6	72	1086.6	114	1176.8
32	1000.0	74	1090.9	116	1181.1
34	1004.3	76	1095.2	118	1185.4
36	1008.7	78	1099.5	120	1189.7
38	1013.0	80	1103.8	122	1194.0
40	1017.3	82	1108.1	124	1198.2

Lennox Industries, Inc. has a continuous product improvement program and reserves the right to change design and specifications without notice.