

CBX25UHV Series

Table of Contents



Unit Dimensions 2

Model Number Information 5

Specifications / Electrical Data 3

Adjusting the BDC3 Blower Control 5

Adjusting the Blower Speed 5

I Application 10

II Unit Components 10

III Optional Electric Heat 13

IV Configuration Modification 17

V Electrical Connections 26

VI Wiring Diagrams 28

VII Performance Checklists 29

VIII Sequence of Operations 29

The CBX25UHV series units are high efficiency blower coils. Several models are available in sizes ranging from 1-1/2 through 5 tons. The CBX25UHV is designed for HFC-410A refrigerant only.

CBX25UHV series units are designed to be matched with the 13SEER air conditioner and heat pump line, but can be matched with other air conditioners or heat pumps as noted in the rating information. See Product Specification bulletin.

The CBX25UHV air handler is designed for indoor installation only. The unit comes ready to install in either up-flow or horizontal left-hand applications. Field modifications are required for right-hand air discharge applications. Electric heat and other accessories are available and are listed in the *CBX25UHV Product Specification* bulletin.

⚠ WARNING

Improper installation, adjustment, alteration, service or maintenance can cause personal injury, loss of life, or damage to property.

Installation and service must be performed by a licensed professional installer (or equivalent) or a service agency.

⚠ CAUTION

Physical contact with metal edges and corners while applying excessive force or rapid motion can result in personal injury. Be aware of, and use caution when working near these areas during installation or while servicing this equipment.

⚠ WARNING

The Clean Air Act of 1990 bans the intentional venting of refrigerant (CFCs, HCFCs and HFCs) as of July 1, 1992. Approved methods of recovery, recycling or reclaiming must be followed. Fines and/or incarceration may be levied for noncompliance.

⚠ IMPORTANT

On some pans, the primary (main) and secondary drain holes have knockouts. Confirm primary (main) and secondary drains are open.

IMPORTANT INFORMATION TO INSTALLER

The thermostatic expansion valve (TEV) with check valve sensing bulb is shipped inside the unit cabinet. This sensing bulb must be re-installed in a proper location outside of the cabinet. See page 22 for details.

Information contained in this manual is intended for use by experienced HVAC service technicians only. All specifications are subject to change. Procedures outlined in this manual are presented as a recommendation only and do not supersede or replace local or state codes.

CBX25UHV Unit Dimensions – Upflow – inches (mm)

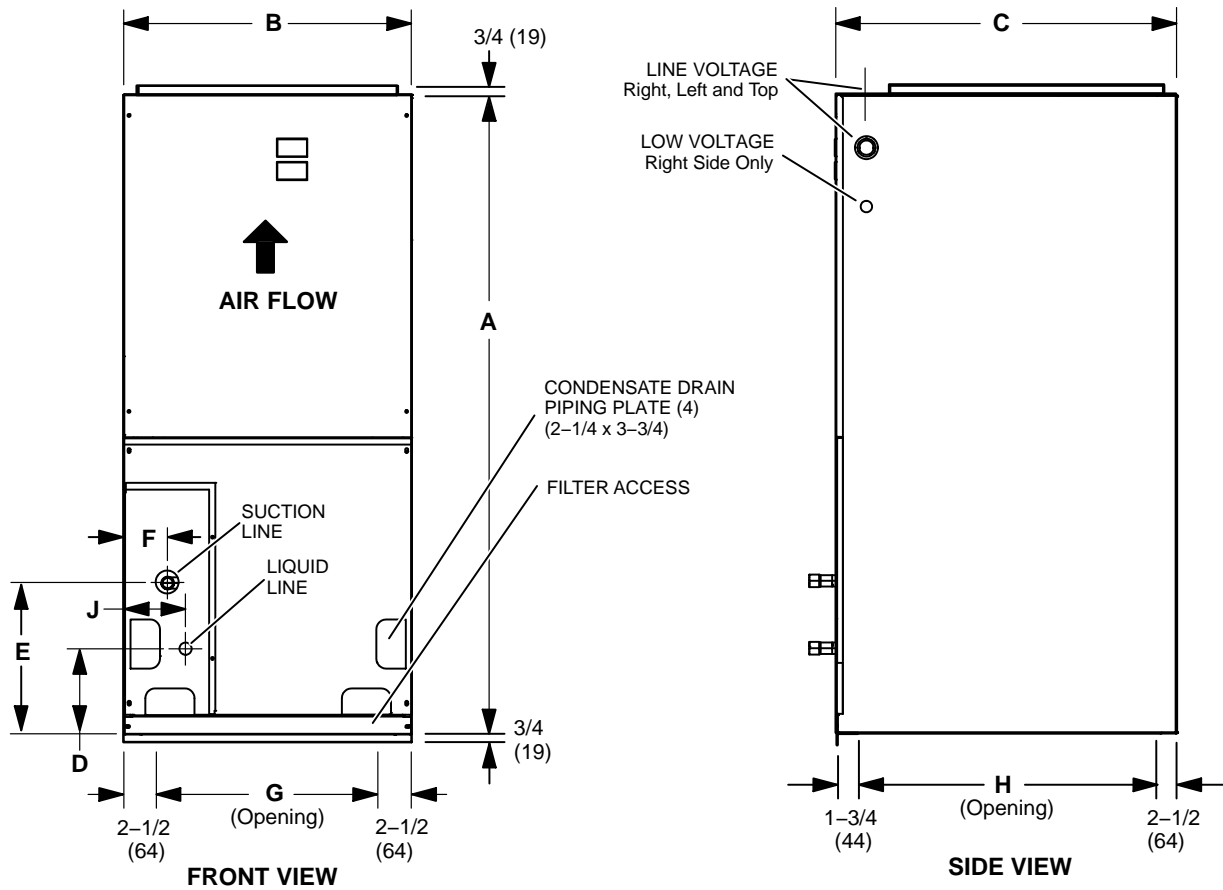

Dimension	-018		-024		-030		-036		-042		-048 / -060		
	inches	mm	inches	mm	inches	mm	inches	mm	inches	mm	inches	mm	
A	38	965	40-1/2	1029	43	1092	48	1219	48	1219	52-1/2	1334	
B	15	381	18-1/2	470	18-1/2	470	21-7/8	556	21-7/8	556	21-7/8	556	
C	22	559	22	559	22	559	22	559	26	660	26	660	
D	6	152	6	152	6	152	12-1/4	311	6-1/4	159	6-3/8	162	
E	11	279	14	357	16	406	18-7/8	479	17-7/8	454	15-1/4	387	
F	3-5/8	92	5-1/2	140	5-1/2	140	5-3/4	146	3-1/4	83	3-1/4	83	
G	10	254	13-1/2	343	13-1/2	343	16-7/8	429	16-7/8	429	16-7/8	429	
H	17-3/4	451	17-3/4	451	17-3/4	451	17-3/4	451	21-3/4	552	21-3/4	552	
J	3-5/8	92	5-1/2	140	5-1/2	140	5-3/4	146	4-5/8	117	6-3/8	162	
Supply Air Opening	Depth	17	432	17	432	17	432	17	432	21	533	21	533
	Width	13	330	16-1/2	419	16-1/2	419	19-7/8	505	19-7/8	505	19-7/8	505
Return Air Opening	Depth	20-3/4	527	20-3/4	527	20-3/4	527	20-3/4	527	24-3/4	629	24-3/4	629
	Width	12-1/2	318	16	406	16	406	19-3/8	492	19-3/8	492	19-3/8	492

CBX25UHV Unit Dimensions – Horizontal – inches (mm)

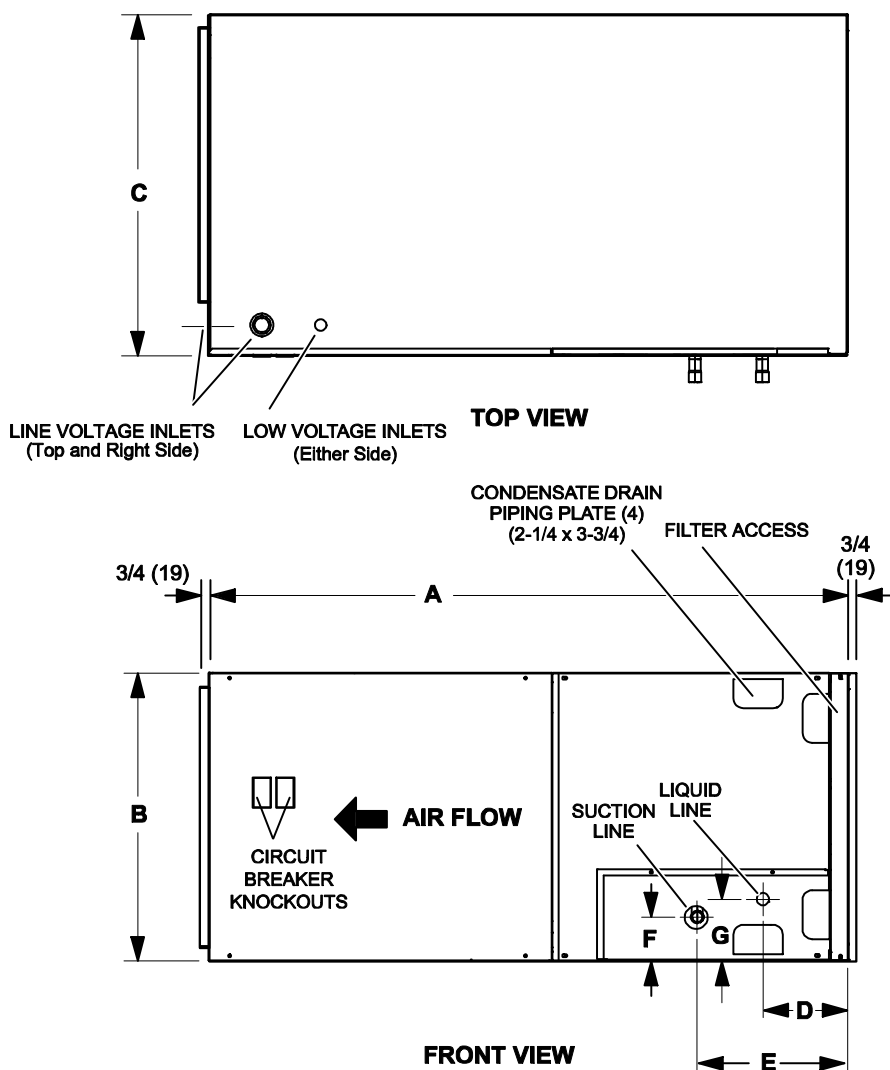

NOTE - Shipped for horizontal left-hand discharge.
 May be field converted to horizontal right-hand air discharge by repositioning horizontal drain pan.

Dimension	-018		-024		-030		-036		-042		-048 / -060		
	inches	mm	inches	mm	inches	mm	inches	mm	inches	mm	inches	mm	
A	38	965	40-1/2	1029	43	1092	48	1219	48	1219	52-1/2	1334	
B	15	381	18-1/2	470	18-1/2	470	21-7/8	556	21-7/8	556	21-7/8	556	
C	22	559	22	559	22	559	22	559	26	660	26	660	
D	6	152	6	152	6	152	12-1/4	311	6-1/4	159	6-3/8	162	
E	11	279	14	357	16	406	18-7/8	479	17-7/8	454	15-1/4	387	
F	3-5/8	92	5-1/2	140	5-1/2	140	5-3/4	146	3-1/4	83	3-1/4	83	
G	3-5/8	92	5-1/2	140	5-1/2	140	5-3/4	146	4-5/8	117	6-3/8	162	
Supply Air Opening	Depth	17	432	17	432	17	432	17	432	21	533	21	533
	Width	13	330	16-1/2	419	16-1/2	419	19-7/8	505	19-7/8	505	19-7/8	505
Return Air Opening	Depth	20-3/4	527	20-3/4	527	20-3/4	527	20-3/4	527	24-3/4	629	24-3/4	629
	Width	12-1/2	318	16	406	16	406	19-3/8	492	19-3/8	492	19-3/8	492

SPECIFICATION

General Data	Model Number	CBX25UHV-018	CBX25UHV-024	CBX25UHV-030	CBX25UHV-036
		Nominal tonnage	1.5	2	2.5
Connections	Suction/Vapor line (o.d.) - in. sweat	3/4	3/4	3/4	7/8
	Liquid line (o.d.) - in. sweat	3/8	3/8	3/8	3/8
	Condensate - in. fpt	(2) 3/4	(2) 3/4	(2) 3/4	(2) 3/4
Indoor Coil	Net face area - ft. ²	3.11	3.56	4.00	4.89
	Tube outside diameter - in.	3/8	3/8	3/8	3/8
	Number of rows	3	3	3	3
	Fins per inch	14	14	14	14
Blower	Wheel nominal diameter x width - in.	9 x 6	9 x 6	10 x 8	10 x 8
	Blower motor output - hp	1/2	1/2	1/2	1/2
¹ Filters	Size of filter - in.	12 x 20 x 1	15 x 20 x 1	15 x 20 x 1	18 x 20 x 1
Shipping Data -1 package - lbs.		105	123	126	161

ELECTRICAL DATA

	Voltage - 1 phase (60 Hz)	208/240V	208/240V	208/240V	208/240V
	² Maximum over-current protection (unit only)	15	15	15	15
	³ Minimum circuit ampacity (unit only)	4.9	4.9	4.9	4.9
	Blower Motor Full Load Amps	3.9	3.9	3.9	3.9

SPECIFICATIONS

General Data	Model Number	CBX25UHV-042	CBX25UHV-048	CBX25UHV-060
		Nominal tonnage	3.5	4
Connections	Suction/Vapor line (o.d.) - in. sweat	7/8	7/8	7/8
	Liquid line (o.d.) - in. sweat	3/8	3/8	3/8
	Condensate - in. fpt	(2) 3/4	(2) 3/4	(2) 3/4
Indoor Coil	Net face area - ft. ²	5.83	7.00	7.00
	Tube outside diameter - in.	3/8	3/8	3/8
	Number of rows	3	3	3
	Fins per inch	14	14	14
Blower	Wheel nominal diameter x width - in.	12 x 8	12 x 9	12 x 9
	Blower motor output - hp	3/4	1	1
¹ Filters	Size of filter - in.	18 x 24 x 1	18 x 24 x 1	18 x 24 x 1
Shipping Data -1 package - lbs.		163	186	186
	Voltage - 1 phase (60 Hz)	208/240V	208/240V	208/240V
	² Maximum overcurrent protection (unit only)	15	15	15
	³ Minimum circuit ampacity (unit only)	6.5	8.6	8.6
	Blower Motor Full Load Amps	5.2	6.9	6.9

¹ Disposable filter.

² HACR type circuit breaker or fuse.

³ Refer to National or Canadian Electrical Code manual to determine wire, fuse and disconnect size requirements. Use wires suitable for at least 167°F.

MODEL NUMBER IDENTIFICATION

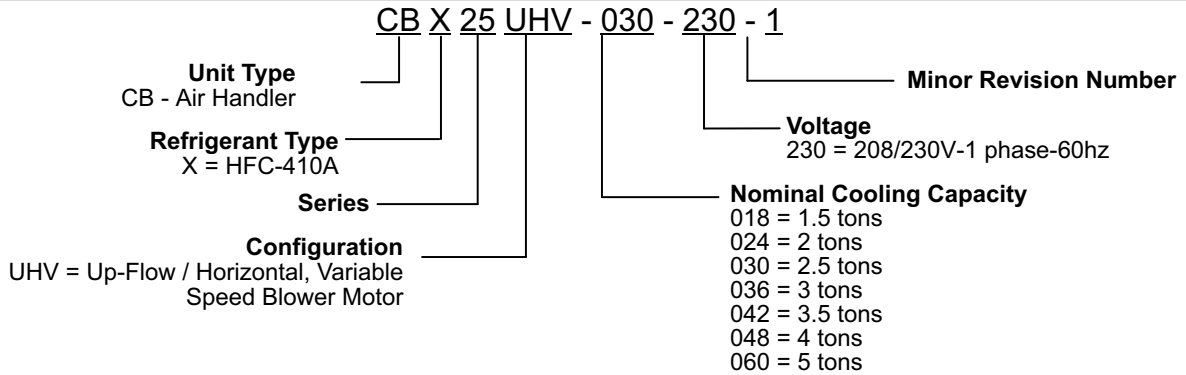

⚠ CAUTION

Electrostatic discharge can affect electronic components. Take precautions during unit installation and service to protect the unit's electronic controls. Precautions will help to avoid control exposure to electrostatic discharge by putting the unit, the control and the technician at the same electrostatic potential. Neutralize electrostatic charge by touching hand and all tools on an unpainted unit surface before performing any service procedure.

CBX25UHV units are equipped with a variable-speed motor that is capable of maintaining a specified CFM throughout the external static range. A particular CFM can be obtained by positioning jumpers (**COOL**, **HEAT**, and **ADJUST**) on the BDC3 control.

The jumpers are labeled 1, 2, 3, and 4. This indicates the selected air volume (CFM). The **ADJUST** jumper is labeled Test, -, +, and Norm. The - and + pin settings are used to add or subtract a percentage of the CFM selected. The Test jumper is used to operate the motor in the test mode. The delay jumper controls the timing pattern in which the fan delay occurs.

Figure 1 illustrates the BDC3 control. Use either table 4 on page 7, or table 5 on page 7 to determine the correct air volume for heat and cool speed taps.

Diagnostic LEDs located on the BDC3 control are provided to aid in identifying the unit's mode of operation. Certain scenarios will arise depending on the jumper positions. Read through the jumper settings sections before adjusting blower speed. Refer to figure 1 on page 5 for identification.

Adjusting the BDC3 Blower Control

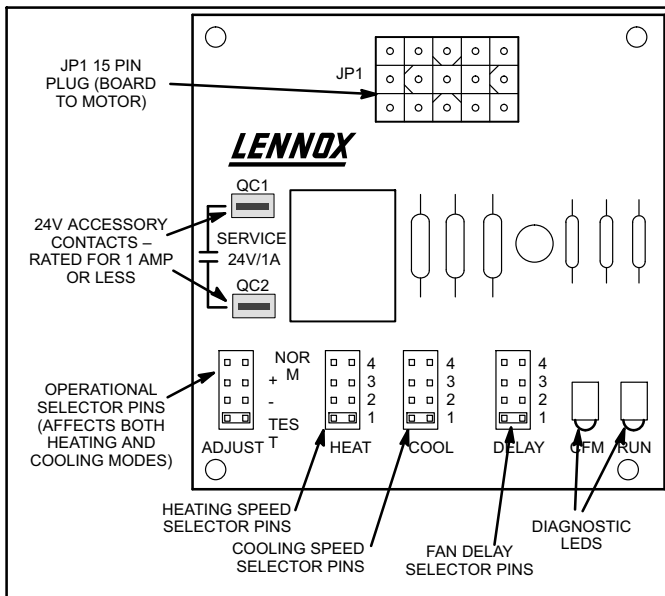

Figure 1. BDC3 Variable Speed Control Selections

Adjusting the Blower Speed

Diagnostic LEDs

- RUN LED** indicates there is a demand for the blower motor to run.
- CFM LED** indicates the cubic feet per minute at which the unit is operating. The light flashes once for approximately every 100 CFM. For example, if the unit is operating at 1000 CFM, **CFM LED** will flash 10 times. If the CFM is 1150, **CFM LED** will flash 11 full times plus one fast or half flash.

At times, the light may appear to flicker or glow. This is normal and occurs when the control is communicating with the motor between cycles.

The appropriate speed, according to application and CFM need, is selected by moving jumper pins.

JUMPER SETTINGS

Table 1 lists the factory blower speed tap settings for CBX25UHV series units. These settings are for nominal tonnage match-ups with the CBX25UHV. When matched with other sizes, it is recommended that the CFM be adjusted to approximately 400 CFM per ton.

WARNING

Before changing jumper setting, make sure the motor has completely stopped. Any jumper setting change will not take place while the motor is running.

DANGER

Disconnect power from unit and wait at least five minutes to allow capacitors to discharge before attempting to adjust motor speed tap settings. Failure to wait may cause personal injury or death.

Table 1. Factory Blower Speed Tap Settings

Air Handler	Speed Tap Selection			
	Cooling		Heating*	
	Note 1	Note 2	Note 3	Note 4
CBX25UHV-018	COOL PIN #2	COOL PIN #2	HEAT PIN #2	HEAT PIN #2
CBX25UHV-024	COOL PIN #3	COOL PIN #3	HEAT PIN #2+	HEAT PIN #2+
CBX25UHV-030	COOL PIN #3	COOL PIN #3	HEAT PIN #2+	HEAT PIN #2+
CBX25UHV-036	COOL PIN #3	COOL PIN #3	HEAT PIN #2	HEAT PIN #2
CBX25UHV-042	COOL PIN #3	COOL PIN #3	HEAT PIN #2	HEAT PIN #2
CBX25UHV-048	COOL PIN #3-	COOL PIN #3-	HEAT PIN #2	HEAT PIN #2
CBX25UHV-060	COOL PIN #3-	COOL PIN #3-	HEAT PIN #2	HEAT PIN #2

NOTES -

1. Condensing Unit
2. Heat Pump
3. Condensing Unit with electric heat only
4. Heat Pump with electric heat

* Minimum setting for heat

To change jumper positions, gently pull the jumper off the pins and insert it onto the desired set of pins. Read the Adjust Jumper, Cool Jumper, Heat Jumper and Delay Jumper sections for details on the different jumper selections available and conditions associated with each one (figure 1 on page 5).

After the CFM for each application is determined, adjust the jumper settings to reflect the CFM given in tables 2 through 8. Determine which table row of CFM volumes most closely matches the desired CFM. Once a specific row has been chosen (+, NORMAL, or -), CFM volumes from other rows cannot be used.

ADJUST JUMPER

The **ADJUST** pins allow the motor to run at normal speed, approximately 10% higher, or approximately 10% lower than normal speed. Table 4 on page 7 lists three rows (+, NORMAL, and -) with their respective CFM volumes. Notice that the normal adjustment setting for heat speed position #3 is 1000 CFM. The + adjustment setting for that position is 1100 CFM and for the - adjustment setting is 895 CFM. After the adjustment setting has been determined, choose the remaining speed jumper settings from those offered in the table in that row.

The TEST pin is available to bypass the BDC3 control and run the motor at approximately 70%, to test that the motor is operational. This is beneficial primarily in troubleshooting. G terminal must be energized for motor to run.

COOL JUMPER

The **COOL** jumper is used to determine the CFM during a cooling demand for either an air conditioner or a heat pump. These jumper selections are activated for cooling when Y2 and DS terminals in the CBX25UHV are energized. They are activated for heating when only Y2 is energized.

Applications **without** the Lennox ComfortSense® 7000 thermostat will provide 70% of the **COOL** CFM during first-stage cooling for two-stage outdoor units. 100% of **COOL** speed is provided for systems with a single-stage outdoor unit.

Applications **with** the Lennox ComfortSense® 7000 thermostat, but no demand for de-humidification will operate as follows: during a first-stage cooling call (two-stage outdoor unit), the air volume is 70% of the **COOL** jumper selection. This arrangement provides for additional dehumidification during standard first-stage cooling. See the tables that follow for various scenarios concerning use of the ComfortSense® 7000 thermostat and the CBX25UHV series unit.

For applications with Harmony III® zone control, the air handler CFM volume is determined by the Harmony III control center. The minimum blower speed is preset to 250 CFM for -018, -024, -030 and -036 units and 450 CFM for -042, -048 and -060 units. This speed is not adjustable. See notes in tables 4 and 5 on page 7.

With the thermostat set for *Continuous Fan* and without a call for heating or cooling, the CBX25UHV provides 50% of the **COOL** CFM selected.

NOTE - For two-stage heat pumps, the air handler operates at 70% of the **COOL** selection until supplemental electric heat is demanded. At that time, the air handler will operate at the selected **HEAT** speed. This arrangement provides warmer supply air during second-stage heating.

Table 2. CBX25UHV-018 Air Handler Performance (0 through 0.80 in. w.g. External Static Pressure Range)

ADJUST Jumper Setting	BDC3 Jumper Speed Position											
	HEAT Speed				First-Stage COOL Speed				Second-Stage COOL Speed			
	1	2	3	4	1	2	3	4	1	2	3	4
	cfm	cfm	cfm	cfm	cfm	cfm	cfm	cfm	cfm	cfm	cfm	cfm
+	470	670	890	1080	350	470	620	760	470	675	890	1090
NORM	440	615	810	1000	350	450	560	700	435	610	815	1020
-	400	560	730	910	350	420	520	650	400	575	725	915

NOTES - The effect of static pressure, filter and electric heater resistance is included in the air volumes listed.
 First-stage cooling air volume is approximately 70% of the second-stage COOL speed setting.
 Continuous fan speed is approximately 50% of second-stage COOL speed setting.
 Lennox Harmony III® Zone Control Applications - Minimum air handler speed is approximately 250 cfm .

Table 3. CBX25UHV-024 Air Handler Performance (0 through 0.80 in. w.g. External Static Pressure Range)

ADJUST Jumper Setting	BDC3 Jumper Speed Positions											
	HEAT Speed				First-Stage COOL Speed				Second-Stage COOL Speed			
	1	2	3	4	1	2	3	4	1	2	3	4
	cfm	cfm	cfm	cfm	cfm	cfm	cfm	cfm	cfm	cfm	cfm	cfm
+	470	690	900	1120	350	470	625	775	480	670	890	1125
NORM	430	640	810	1020	330	450	580	720	430	605	820	1020
-	410	550	720	900	300	405	505	650	390	545	740	930

NOTES - The effect of static pressure, filter and electric heater resistance is included in the air volumes listed.
 First-stage cooling air volume is approximately 70% of the second-stage COOL speed setting.
 Continuous fan speed is approximately 50% of second-stage COOL speed setting.
 Lennox Harmony III® Zone Control Applications - Minimum air handler speed is approximately 250 cfm.

Table 4. CBX25UHV-030 Air Handler Performance (0 through 0.80 in. w.g. External Static Pressure Range)

ADJUST Jumper Setting	BDC3 Jumper Speed Positions											
	HEAT Speed				First-Stage COOL Speed				Second-Stage COOL Speed			
	1	2	3	4	1	2	3	4	1	2	3	4
	cfm	cfm	cfm	cfm	cfm	cfm	cfm	cfm	cfm	cfm	cfm	cfm
+	650	900	1100	1320	430	600	740	920	650	875	1100	1330
NORM	590	795	1000	1200	390	550	680	830	580	800	1000	1200
-	520	730	895	1075	340	475	620	750	500	700	900	1090

NOTES - The effect of static pressure, filter and electric heater resistance is included in the air volumes listed.
 First-stage cooling air volume is approximately 70% of the second-stage COOL speed setting.
 Continuous fan speed is approximately 50% of second-stage COOL speed setting.
 Lennox Harmony III® Zone Control Applications - Minimum air handler speed is approximately 250 cfm.

Table 5. CBX25UHV-036 Air Handler Performance (0 through 0.80 in. w.g. External Static Pressure Range)

ADJUST Jumper Setting	BDC3 Jumper Speed Positions											
	HEAT Speed				First-Stage COOL Speed				Second-Stage COOL Speed			
	1	2	3	4	1	2	3	4	1	2	3	4
	cfm	cfm	cfm	cfm	cfm	cfm	cfm	cfm	cfm	cfm	cfm	cfm
+	880	1115	1345	1435	615	770	930	1090	880	1110	1340	1435
NORM	800	1010	1215	1425	555	695	845	990	795	1005	1215	1420
-	715	905	1095	1275	505	625	755	885	715	905	1090	1280

NOTES - The effect of static pressure, filter and electric heater resistance is included in the air volumes listed.
 First-stage cooling air volume is approximately 70% of the second-stage COOL speed setting.
 Continuous fan speed is approximately 50% of second-stage COOL speed setting.
 Lennox Harmony III® Zone Control Applications - Minimum air handler speed is approximately 250 cfm.

Table 6. CBX25UHV-042 Air Handler Performance (0 through 0.80 in. w.g. External Static Pressure Range)

ADJUST Jumper Setting	BDC3 Jumper Speed Positions											
	HEAT Speed				First-Stage COOL Speed				Second-Stage COOL Speed			
	1	2	3	4	1	2	3	4	1	2	3	4
	cfm	cfm	cfm	cfm	cfm	cfm	cfm	cfm	cfm	cfm	cfm	cfm
+	1115	1345	1560	1800	800	960	1120	1265	1130	1360	1580	1800
NORM	1025	1215	1415	1630	730	870	1020	1150	1040	1240	1450	1640
-	925	1110	1280	1460	650	790	915	1050	950	1120	1290	1470

NOTES - The effect of static pressure, filter and electric heater resistance is included in the air volumes listed.
 First-stage cooling air volume is approximately 70% of the second-stage COOL speed setting.
 Continuous fan speed is approximately 50% of second-stage COOL speed setting.
 Lennox Harmony III® Zone Control Applications - Minimum air handler speed is approximately 450 cfm.

Table 7. CBX25UHV-048 Air Handler Performance (0 through 0.80 in. w.g. External Static Pressure Range)

ADJUST Jumper Setting	BDC3 Jumper Speed Positions											
	HEAT Speed				First-Stage COOL Speed				Second-Stage COOL Speed			
	1	2	3	4	1	2	3	4	1	2	3	4
	cfm	cfm	cfm	cfm	cfm	cfm	cfm	cfm	cfm	cfm	cfm	cfm
+	1450	1670	1880	2340	1050	1200	1340	1650	1440	1670	1950	2340
NORM	1340	1520	1730	2100	950	1200	1230	1520	1325	1530	1740	2150
-	1210	1390	1570	1915	850	1000	1100	1375	1200	1380	1600	1950

NOTES - The effect of static pressure, filter and electric heater resistance is included in the air volumes listed.
 First-stage cooling air volume is approximately 70% of the second-stage COOL speed setting.
 Continuous fan speed is approximately 50% of second-stage COOL speed setting.
 Lennox Harmony III® Zone Control Applications - Minimum air handler speed is approximately 450 cfm.

Table 8. CBX25UHV-060 Air Handler Performance (0 through 0.80 in. w.g. External Static Pressure Range)

ADJUST Jumper Setting	BDC3 Jumper Speed Positions											
	HEAT Speed				First-Stage COOL Speed				Second-Stage COOL Speed			
	1	2	3	4	1	2	3	4	1	2	3	4
	cfm	cfm	cfm	cfm	cfm	cfm	cfm	cfm	cfm	cfm	cfm	cfm
+	1700	1930	2120	2275	1225	1410	1530	1690	1720	1930	2140	2270
NORM	1570	1760	1925	2100	1120	1260	1400	1540	1580	1765	1970	2100
-	1420	1595	1760	1920	1015	1160	1275	1390	1430	1625	1780	1890

NOTES - The effect of static pressure, filter and electric heater resistance is included in the air volumes listed.
 First-stage cooling air volume is approximately 70% of the second-stage COOL speed setting.
 Continuous fan speed is approximately 50% of second-stage COOL speed setting.
 Lennox Harmony III® Zone Control Applications - Minimum air handler speed is approximately 450 cfm.

Table 9. CBX25UHV, Thermostat and Single-Stage Outdoor Unit Operating Sequence

Operating Sequence		System Demand								System Response		
System Condition	Step	Thermostat Demand				Relative Humidity				Com-pressor	Air Handler CFM (COOL)	Comments
		Y1	Y2	O	G	W1	W2	Status	D			
NO CALL FOR DEHUMIDIFICATION												
Normal Operation	1	On		On	On			Acceptable	24 VAC	High	100%	Compressor and indoor air handler follow thermostat demand.
BASIC MODE (only active on a Y1 thermostat demand)												
Normal Operation	1	On		On	On			Acceptable	24 VAC	High	100%	Thermostat energizes Y1 and de-energizes D on a call for dehumidification.
Dehumidification Call	2	On		On	On			Demand	0 VAC	High	60%/65% 70%*	
PRECISION MODE (operates independent of a Y1 thermostat demand)												
Normal Operation	1	On		On	On			Acceptable	24 VAC	High	100%	Dehumidification mode begins when humidity is greater than set point.
Dehumidification call	2	On		On	On			Demand	0 VAC	High	60%/65% 70%*	
Dehumidification call ONLY	1	On		On	On			Demand	0 VAC	High	60%/65% 70%*	Thermostat will try to maintain room humidity setpoint by allowing the room space to maintain a cooler room thermostat setpoint.**
Jumpers at indoor unit with a single stage outdoor unit With Condensing unit - Y1 to Y2 and R to O With Heat Pump - Y1 to Y2												
* During dehumidification, cooling air handler speed is as follows: 70% of second-stage COOL cfm for 018, 024, 030, 65% for 036 and 60% for 042, 048 and 060 units. ** Thermostat will maintain the room temperature up to 2°F (1.2°C) cooler than the room thermostat setting in precision mode.												

Table 10. CBX25UHV, Thermostat and Two-Stage Outdoor Unit Operating Sequence

Operating Sequence		System Demand								System Response		
System Condition	Step	Thermostat Demand						Relative Humidity		Com-pressor	Air Handler CFM (COOL)	Comments
		Y1	Y2	O	G	W1	W2	Status	D			
NO CALL FOR DEHUMIDIFICATION												
Normal Operation - Y1	1	On		On	On			Acceptable	24 VAC	Low	70%	Compressor and indoor air handler follow thermostat demand.
Normal Operation - Y2	2	On	On	On	On			Acceptable	24 VAC	High	100%	
Room Thermostat Calls for First-Stage Cooling												
BASIC MODE (only active on a Y1 thermostat demand)												
Normal Operation	1	On		On	On			Acceptable	24 VAC	Low	70%	Thermostat energizes Y2 and de-energizes D on a call for dehumidification.
Dehumidification Call	2	On	On	On	On			Demand	24 VAC	High	60%/65% 70%*	
PRECISION MODE (operates independent of a Y1 thermostat demand)												
Normal Operation	1	On		On	On			Acceptable	24 VAC	Low	70%	Dehumidification mode begins when humidity is greater than set point.
Dehumidification call	2	On	On	On	On			Demand	0 VAC	High	60%/65% 70%*	
Dehumidification call ONLY	1	On	On	On	On			Demand	0 VAC	High	60%/65% 70%*	Thermostat will try to maintain room humidity setpoint by allowing the room space to maintain a cooler room thermostat setpoint.**
Room Thermostat Calls for First- and Second-Stage Cooling												
BASIC MODE (only active on a Y1 thermostat demand)												
Normal Operation	1	On	On	On	On			Acceptable	24 VAC	High	100%	Thermostat energizes Y2 and de-energizes D on a call for dehumidification
Dehumidification Call	2	On	On	On	On			Demand	0 VAC	High	60%/65% 70%*	
PRECISION MODE (operates independent of a Y1 thermostat demand)												
Normal Operation	1	On	On	On	On			Acceptable	24 VAC	High	100%	Dehumidification mode begins when humidity is greater than set point
Dehumidification call	2	On	On	On	On			Demand	0 VAC	High	60%/65% 70%*	
Dehumidification call ONLY	1	On	On	On	On			Demand	0 VAC	High	60%/65% 70%*	Thermostat will try to maintain room humidity setpoint by allowing the room space to maintain a cooler room thermostat setpoint**
	Jumpers at indoor unit with a two-stage outdoor unit With Condensing unit - Y2 and R to O With Heat Pump - none											Thermostat will try to maintain room humidity setpoint by allowing the room space to maintain a cooler room thermostat setpoint**
* During dehumidification, cooling air handler speed is as follows: 70% of COOL cfm for 018, 024, 030, 65% for 036, 60% for 042, 048 and 060 units.												
** Thermostat will maintain the room temperature up to 2°F (1.2°C) cooler than the room thermostat setting in precision mode.												

HEAT JUMPER

The **HEAT** jumper is used to determine CFM during electric heat operation only. These jumper selections are activated only when W1 is energized.

DELAY JUMPER

The **DELAY** jumper is used to set the specific motor fan operation during cooling mode. Depending on the application, one of four options may be chosen by moving the jumper to the appropriate set of pins.

#1 Pins Jumpered —

A Motor runs at 100% until demand is satisfied.

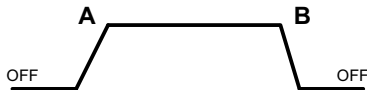

B Once demand is met, motor ramps down to stop.

#2 Pins Jumpered —

A Motor runs at 100% until demand is satisfied.

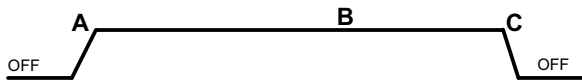

B Once demand is met, motor runs at 100% for 60 seconds.

C Motor ramps down to stop.

NOTE - Air Handler OFF DELAY also applies during heat pump operation

#3 Pins Jumpered —

A Motor runs at 82% for approximately 7-1/2 minutes.

B If demand has not been satisfied after 7-1/2 minutes, the motor runs at 100% until demand is satisfied.

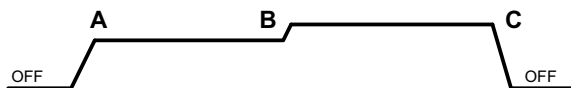

C Once demand is met, motor ramps down to stop.

#4 Pins Jumpered —

A Motor runs at 50% for 30 seconds.

B Motor then runs at 82% for approximately 7-1/2 minutes.

C If demand has not been satisfied after 7-1/2 minutes, the motor runs at 100% until demand is satisfied.

D Once demand is met, motor runs at 50% for 30 seconds.

E After 30 seconds at 50%, motor ramps down to stop.

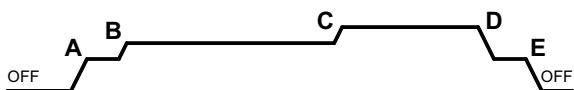

I-APPLICATION

Match all major blower coil components according to Lennox recommendations, failure to comply voids warranty. Refer to the Product Specification bulletin for approved system matchups. Improperly matched systems result in erratic operation and can result in early unit failure. The units come with factory-installed check/expansion valve for all applications. The TEV valve has been installed internally for a cleaner installation and is accessible if required.

II-UNIT COMPONENTS

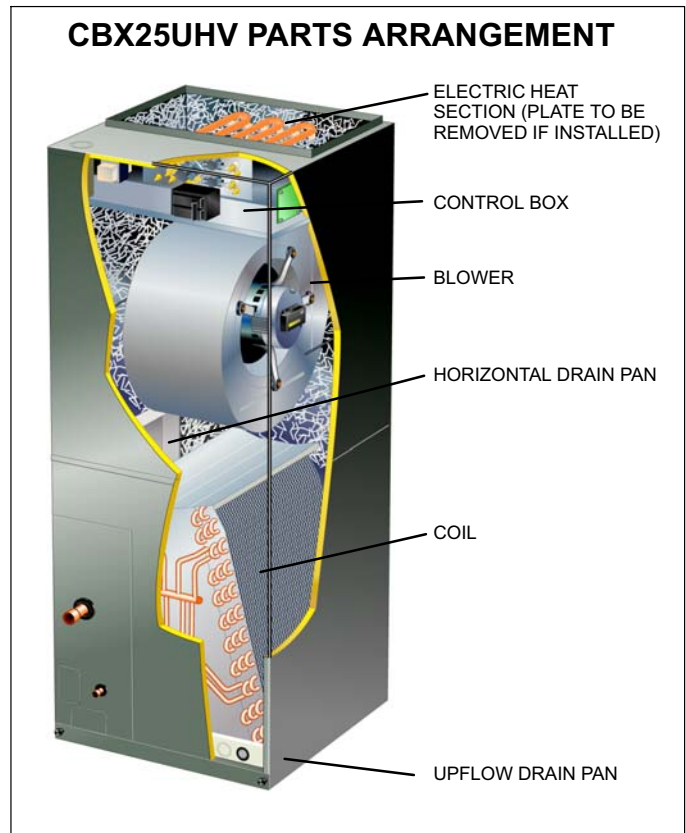

Figure 2. Parts Arrangement

A-Control Box

The CBX25UHV control box is located above the blower section shown in figure 2. Line voltage and electric heat connections are made in the control box. Optional electric heat fits through an opening located in the center of the control box. When electric heat is not used, cover plates cover the opening. The electric heat control arrangement is detailed in the electric heat section of this manual.

B-Transformer

All CBX25UHV series units use a single line voltage to 24VAC transformer mounted in the control box. The transformer supplies power to the control circuits in the indoor and outdoor unit. Transformers are rated at 40VA. 208/240VAC single phase transformers use two primary voltage taps as shown in figure 3.

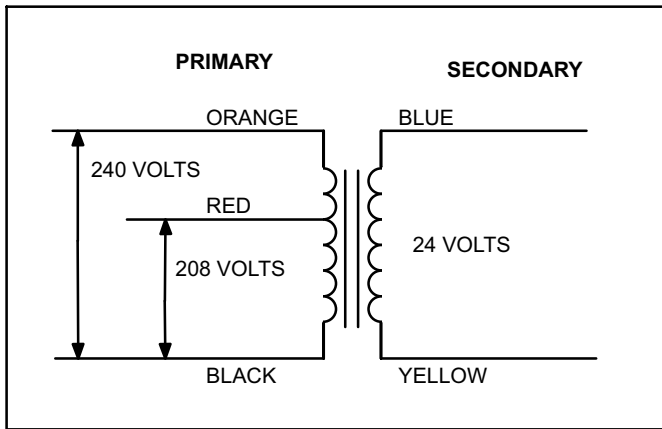

Figure 3. Transformer

C-Variable Speed Blower Motor (ECM) (B3)

CBX25UHV units are equipped with a variable-speed motor that is capable of maintaining a specified CFM throughout the external static range. Figure 4 shows the parts arrangement.

⚠ WARNING

During blower operation, the ECM motor emits energy that may interfere with pacemaker option. Interference is reduced by both the sheet metal cabinet and distance.

All units are factory wired for heat pump and cooling applications with or without electric heat.

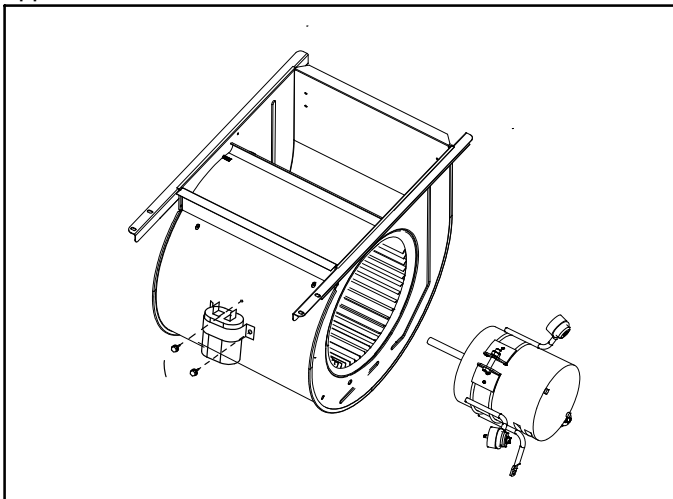

Figure 4. Blower Assembly

Variable Speed Motor Checkout

⚠ DANGER

Disconnect power from unit and wait at least five minutes to allow capacitors to discharge before attempting to adjust motor speed tap settings. Failure to wait may cause personal injury or death.

When line voltage is first applied to a motor, a large inrush of power charges a bank of capacitors inside the controller.

Wait five minutes minimum after turning off power to allow capacitors to discharge.

It is normal for a variable speed motor to gently rock back and forth at the beginning of operation. During this time period the solid-state controller is determining the exact position of the rotor. Once the motor begins turning, the solid-state controller slowly eases the motor up to speed. This is referred to as a soft-start. On start-up, it may take the motor 10 to 15 seconds to reach its full speed.

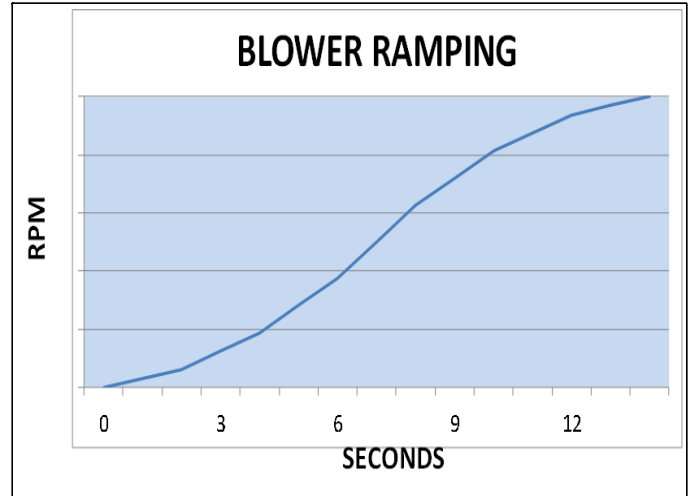

Figure 5. Blower Ramping

Test 1: Determine if Unit has Power

1. Remove the 5-pin power plug from the motor and apply power. Using a digital multimeter check to determine if 240VAC is present between pins 4 and 5 (see figure 6).
2. If 240V is not present at pins 4 and 5. Check power source and cable assembly and retest.
3. If 240VAC is present at pins 4 and 5, then reconnect the plug to the motor. Because 240 volts is present at the motor end of the harness, this indicates there is power to the air handler and connecting harnesses is good. It's time to move to Test 2.

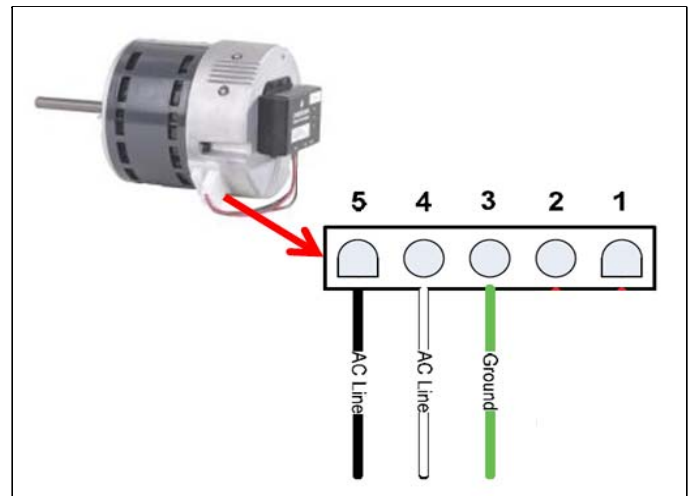

Figure 6. 5-Pin Power Plug (Pins 4 and 5)

Test 2: Determine if Unit has Power and Command Signal

1. Remove the 16-pin low-voltage plug from the motor.
2. With 240V power applied to the air handler, check for the presences of 24VAC at pins 1 and 12

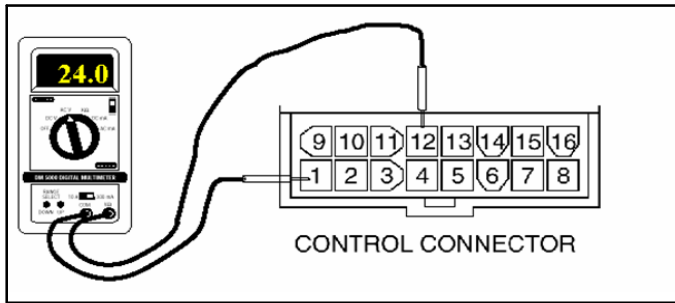

Figure 7. 16-Pin Power Plug (Pins 1 and 12)

3. Install field-provided test jumper between the plug pins 12 and 15 to apply 24VAC to the motor. Motor should run at continuous speed. This test isolates the motor and module from the integrated control. If the motor runs in this test, motor is good.

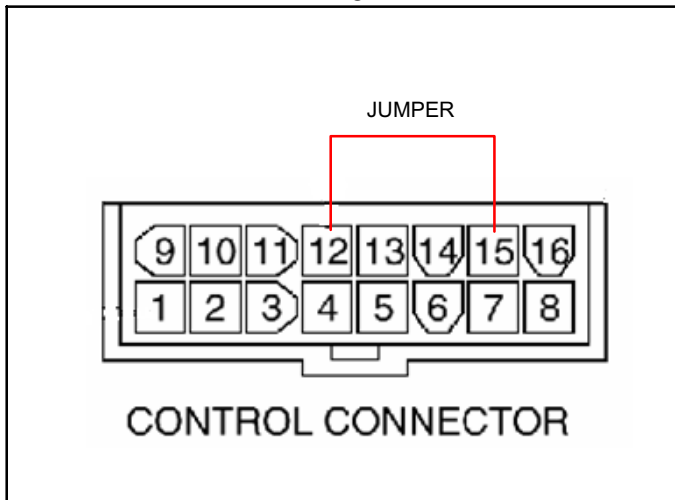

Figure 8. 16-Pin Plug (Pins 12 and 15)

Test 2: Determine if Unit has Power and Command Signal (using TECHMatePro™ service tool)

An option for Test 2 is to use the TECHMatePRO™ service tool (Lennox catalog number X2655) with the 16-pin plug in to apply 24V to the pins.

Using this tool eliminates the risk of applying power to the wrong pins.

Since there is very little blower compartment space removing the plug from the motor and the service tool plug is easier than trying to use jumpers to place 24VAC to the correct pins directly on the motor. Follow the instructions provided with the kit. If the motor runs, do not replace it.

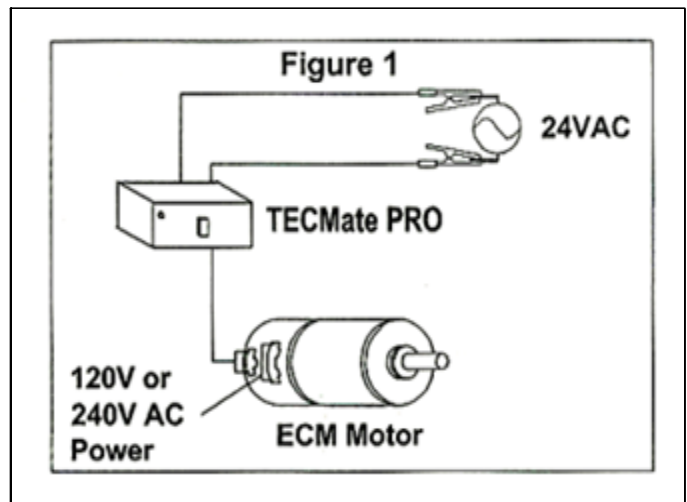

Figure 9. Using TECHMatPro™ Tool

Test 3: Testing Motor Windings (Line to Ground)

Ohm out the motor windings from each terminal in the connector to ground.

- Set the meter to the highest ohms scale.
- If all of these readings are above 100,000 ohms. The motor is good.
- Typically a good motor will show all readings in infinity (I), (OL), or (Open). If any of these readings is below 100,000 ohms, the motor has failed and must be replaced.

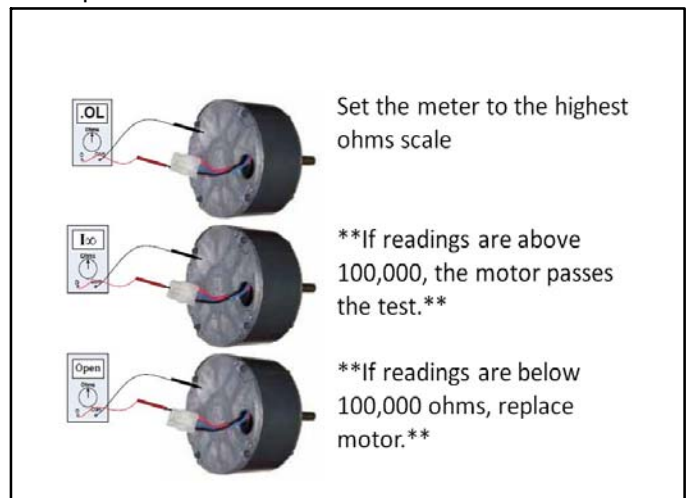

Figure 10. Testing Motor Windings (Line to Ground)

Test 3: Testing Motor Windings (Winding to Winding)

To test the motor through the 3-pin connector; Winding-To-Winding:

1. Ohm out the phases from one terminal to the other in the connector.

2. Set the meter to the lowest ohms scale.

If the readings are all less than 20 ohms and within +/- 10% of each other, the motor passes this test. If not, the motor has failed and must be replaced.

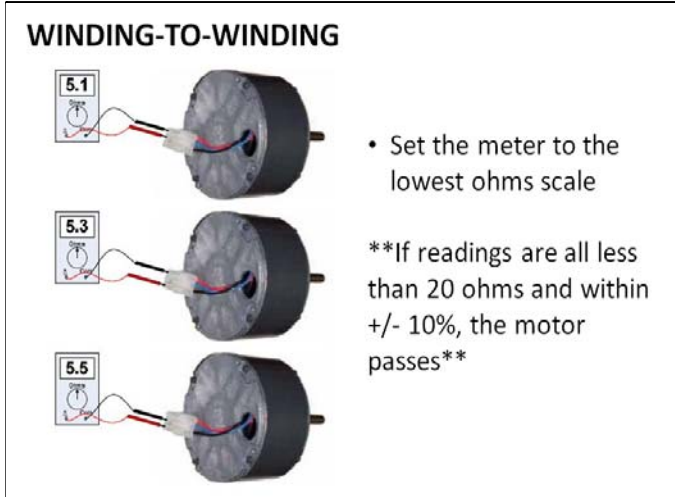

Figure 11. Testing Motor Windings (Winding to Winding)

D-Coil

CBX25UHV units have dual slab coils arranged in an **A** configuration. Each coil has two or three rows of copper tubes fitted with ripple-edged aluminum fins. An expansion valve, feeds multiple parallel circuits through the coils. The coil is designed to easily slide out of the unit cabinet.

E-Drain Pans

Drain pans are provided and installed on the CBX25UHV.

Upflow Applications

NOTE - If the unit is installed in the upflow position, the horizontal drain pan must be removed to ensure best air flow and efficiency.

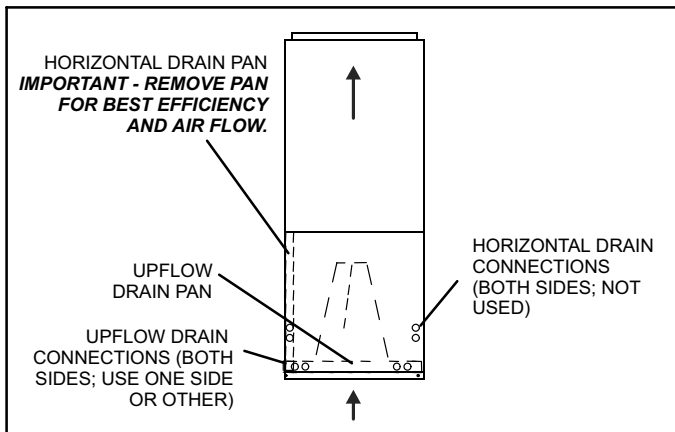

Figure 12. Upflow Configuration

Horizontal Applications

NOTE - The unit is shipped with the horizontal drain pan positioned for left-hand air discharge. The drain pan and blow-off prevention bracket (-030 and larger units only) must be removed and repositioned for use in right-hand air discharge applications.

NOTE - When the unit is installed in horizontal applications, a secondary drain pan is recommended. Refer to local codes.

Units installed in a horizontal position must be sloped slightly downward toward the drain connections to ensure good drainage.

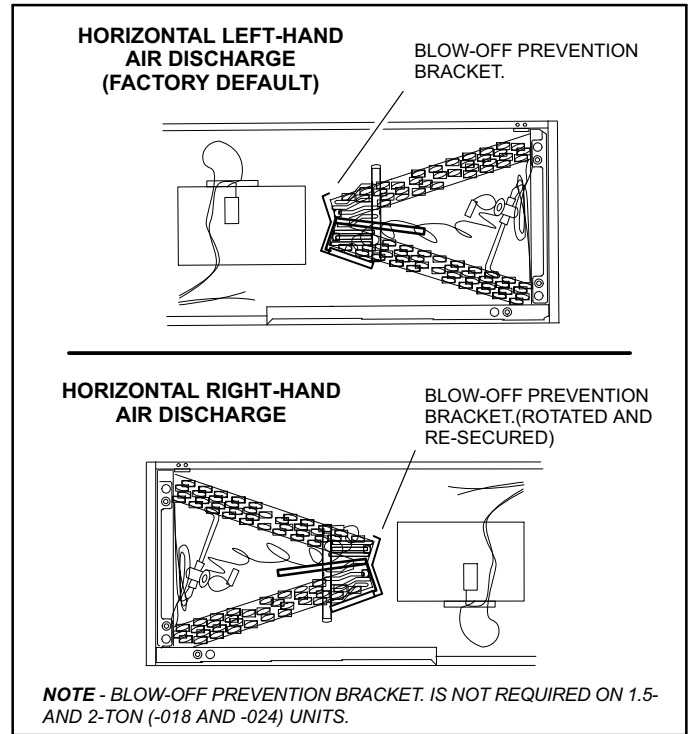

Figure 13. Horizontal Left-Hand Air Discharge

III-OPTIONAL ECB25 ELECTRIC HEAT

Optional ECB25 electric heat sections provide field-installed electric heat for air handler units.

Table 11 shows the available heat sections. Refer to the Product Specifications for heat section applications.

Table 11. Electric Heat Sections

Description	Catalog Number
2.5 KW with stripped wires	89W42
5 KW with terminal block	89W43
5 KW with 30-amp circuit breaker	89W44
7.5 KW with terminal block	89W45
7.5 KW with 45-amp circuit breaker	89W46
10 KW with terminal block	10Z43
10 KW with 60-amp circuit breaker	10T37
12.5 KW with 25- and 50-amp circuit breakers	89W49
15 KW with 30- and 60-amp circuit breakers	10T14
20 KW with two (2) 60-amp circuit breakers	10T35

A-Heat Section Installation

Disconnect all power to the unit before servicing and installing this equipment. Use proper tools and protective equipment during installation and service.

Before installing the unit, check information on the unit rating plate to ensure that the unit meets the job specification, proper electrical power is available, and that proper duct clearances are maintained.

⚠ CAUTION

Physical contact with metal edges and corners while applying excessive force or rapid motion can result in personal injury. Be aware of, and use caution when working near these areas during installation or while servicing this equipment.

⚠ WARNING

Before installing or servicing unit, be sure ALL power to the unit is OFF. More than one disconnect switch may be present. *Electrical shock can cause personal injury or death!*

NOTE - If installing heat sections at the same time as the air handler unit, install the electric heat section in the air handler unit before setting the air handler unit and attaching the plenum.

1. Shut off all power to the air handler unit. More than one disconnect may be required.
2. Remove air handler access panel and keep the six screws to reattach access panel after installing heat elements.
3. Disconnect any existing field supply wires and pull them out of the air handler. Disconnect and remove wiring harness and fastener. If not removed, these items will prevent the heat section's base from resting properly in the compartment.
4. Remove the no-heat seal plate in the air handler frame.
5. Slide the electric heat section into the air handler. Be careful that the heating elements do not rub against the sheet metal opening when they slide into the air handler. The side opposite the side with the mounting holes should slip behind the offset. The mounting holes

should then line up with holes in the air handler control box.

6. Secure the electric heater assembly with the screws that were removed from the heat element panel. Install two field-provided #8 self-drilling, self-taping (SDST) screws in the front of the electric heater assembly (see figure 14).

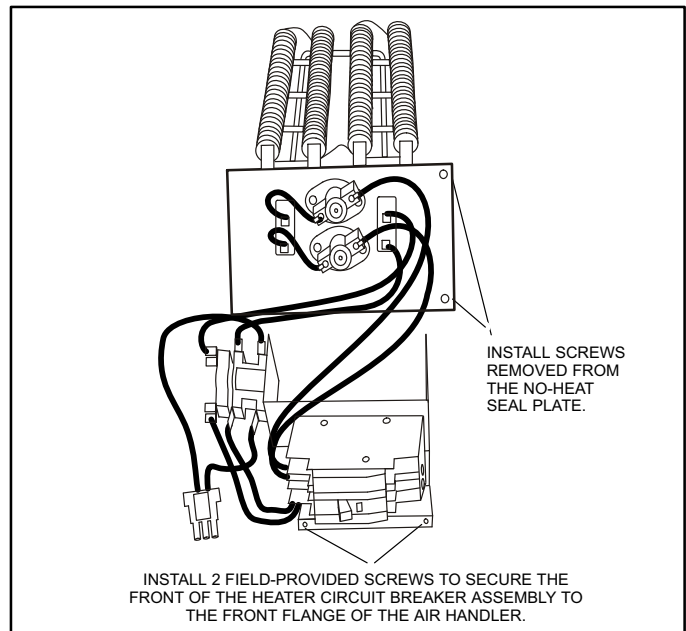

Figure 14. Installing the Heat Element Assembly

7. The air handler access panels have knockouts over the circuit breaker opening. Knock out both plates to accommodate the circuit breaker levers. If installing a heat element assembly with circuit breakers, remove the knockouts but do not install the access panel until all electrical connections have been completed.

⚠ WARNING

Foil face insulation must be cut to eliminate the possibility for any frayed foil to coming in contact with any main or low voltage connections. Insulation must be kept a minimum of 1/2" away from any electrical connection.

B-Changing Circuit Breaker Orientation

The air handler comes from the factory setup for horizontal left-hand discharge which requires no change in the circuit breaker orientation. However, if the air handler is installed in a horizontal right-hand discharge position, rotate the breaker 180°. The circuit breaker orientation change is required by UL 1995, Article 26.18 (25 September 2005).

1. The factory default configuration for the two circuit breakers is horizontal left-hand discharge which requires no change (see figure 16). To change the applicable circuit breakers orientation for right-hand discharge, proceed to step 2.
2. Locate the one clip which is located on the right side of each breaker (see figure 15). The clip secures the circuit breaker to the mounting bracket. Pull the clip to release the breaker from the mounting bracket.
3. Flip the breaker so that the wires attached to the circuit breakers terminals are on the left side (see figure 16).
4. Use the black clip to reattach the circuit breaker to the mounting bracket.

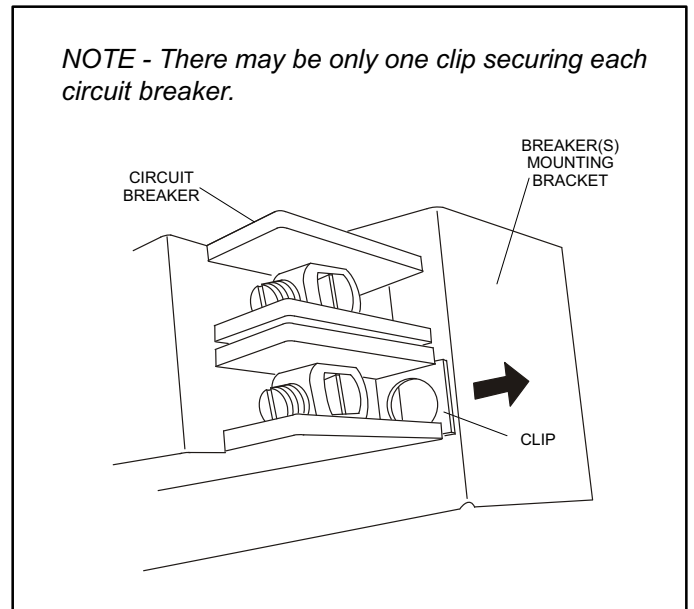

Figure 15. Circuit Breaker Clip

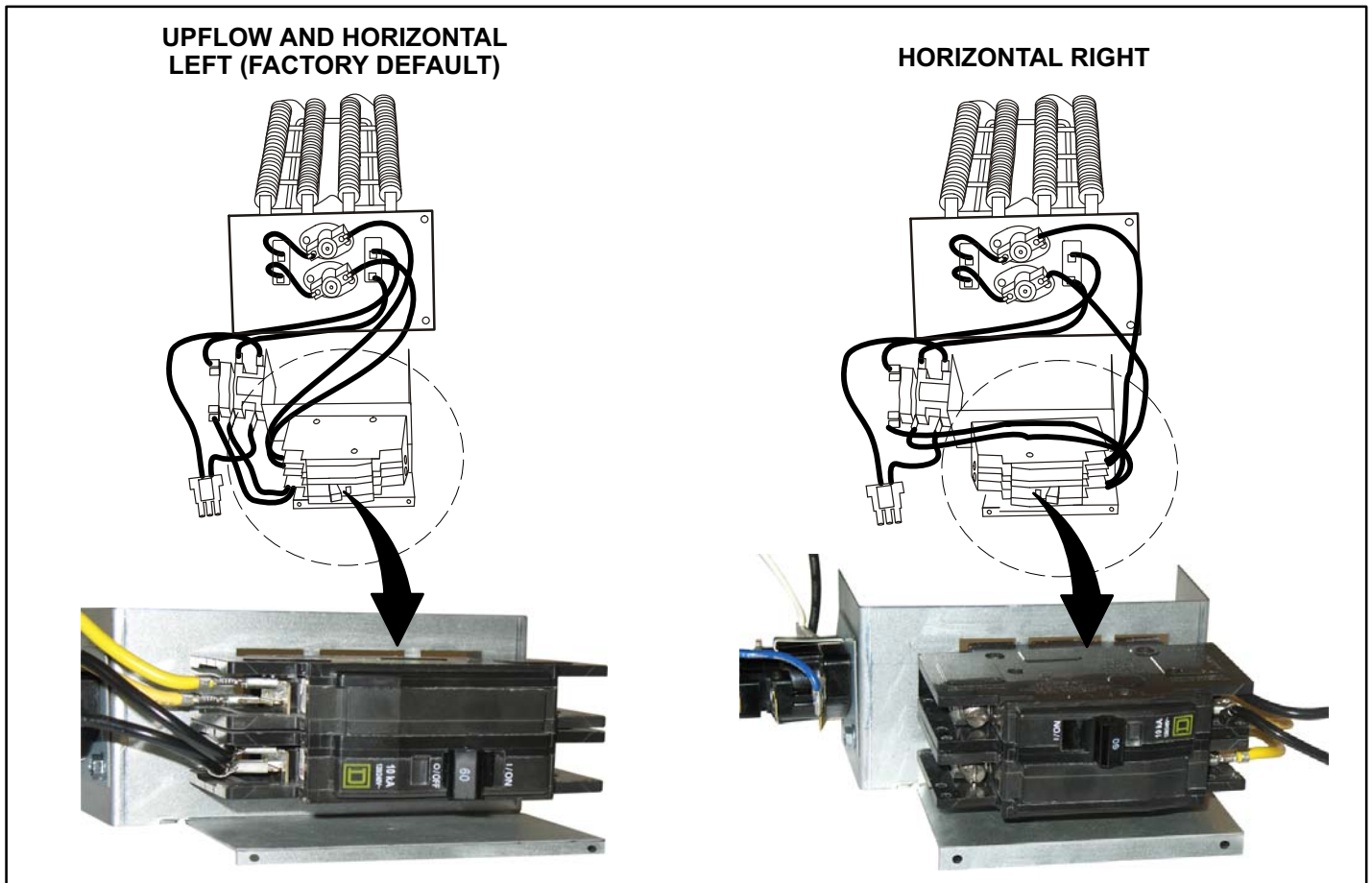

Figure 16. Circuit Breaker Orientation

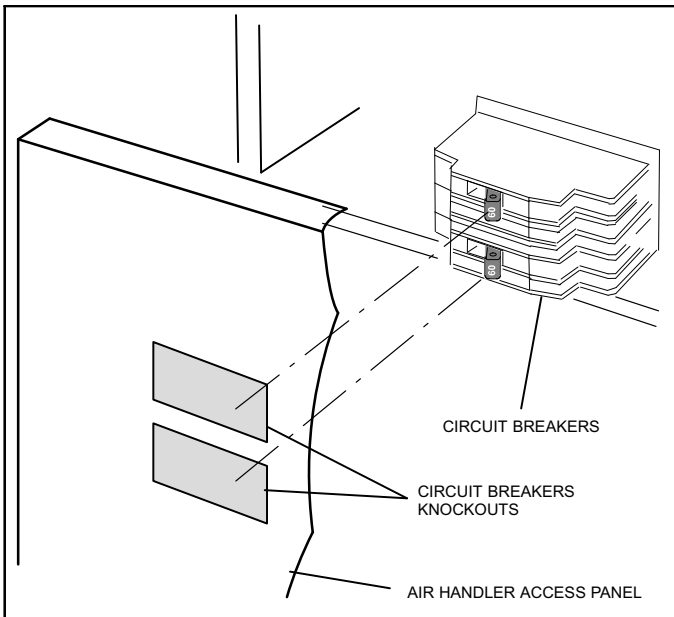

Figure 17. Circuit Breaker Knockouts

C-Electrical Connections

⚠ WARNING

Electric shock hazard! - Disconnect all power supplies before servicing. Replace all parts and panels before operating. Failure to do so can result in death or electrical shock.

⚠ WARNING

USE COPPER CONDUCTORS ONLY.

NOTE - Refer to the nameplate on the air handler unit for minimum circuit ampacity and maximum overcurrent protection size.

The air handler units are provided with openings to be used with 1-1/2 inch trade size (1-31/32 inch diameter) conduit.

If the installation requires a single point power supply, refer to the nameplate on the single point power supply accessory for minimum circuit ampacity and maximum overcurrent protection size. Select the proper supply circuit conductors in accordance with tables 310-16 and 310-17 in the National Electrical Code, ANSI/NFPA No. 70 or tables 1 through 4 in the Canadian Electric Code, Part I, CSA Standard C22.1.

Refer to figure 37 for typical low voltage field wiring for air handler/condensing unit and heat pump applications. Figure 18 is a diagram of the air handler connections and the heater elements high-voltage wiring.

1. Make wiring connections as follows:

Heaters equipped with circuit breakers—Connect field power supply wiring to circuit breaker(s). Figure 18

shows L1, L2 and ground GND connections for a 2-breaker configuration.

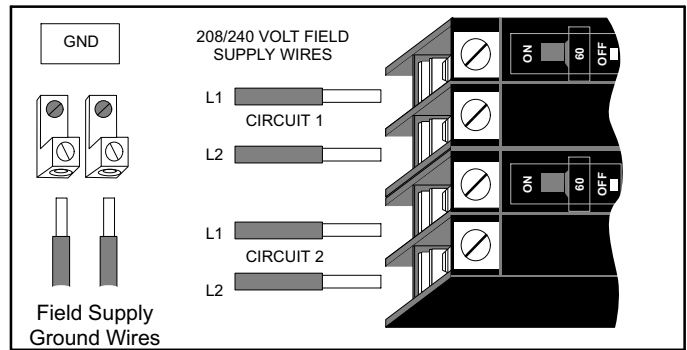

Figure 18. Field Power Supply Wiring

Heaters equipped with terminal blocks—Connect field power supply wiring to terminal block(s). Figure 19 shows L1, L2 and ground (GND) connection for a terminal block configuration.

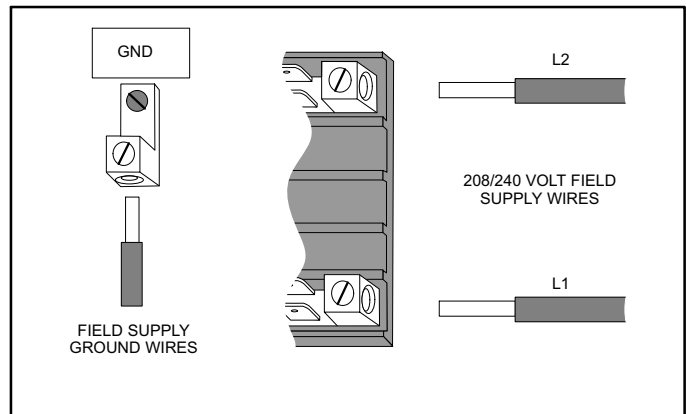

Figure 19. Terminal Block Connections

2. Remove the interface harness from the air handler unit and connect the 6-pin connector on the heater assembly to the mating connector on the air handler unit.

D-Circuit Breaker Cover Installation

1. Remove any installed patch plates.
2. Remove paper covering adhesive back around backside perimeter of circuit breaker cover (figure 20).
3. Position the breaker cover over the air handler circuit breaker opening (figure 21).

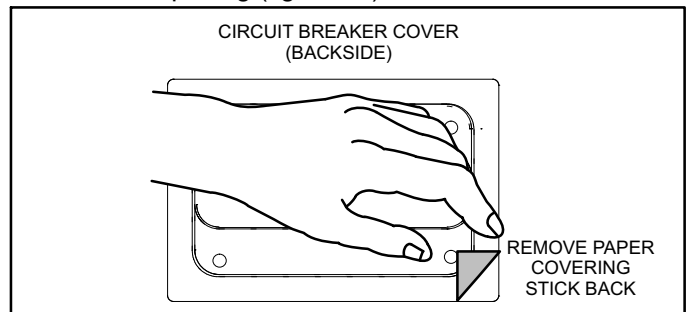

Figure 20. Remove Paper Cover

⚠ WARNING

Confirm air tight seal between breaker cover and air handler access panel. Apply a thin silicone bead to the adhesive back seat to ensure air tight seal.

Failure to seal circuit breaker cover will allow warm moist air to be pulled into control panel which can create condensation to form on the circuit breaker and other electrical components within the control panel.

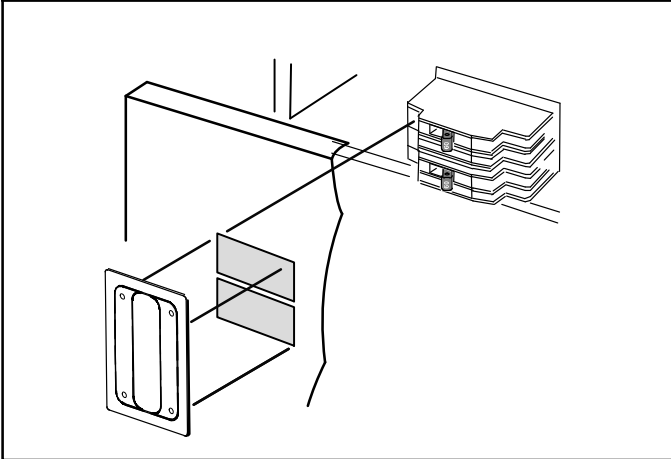

Figure 21. Typical Circuit Breaker Cover Installation

E-Air Handler Speed Connections

When using the electric heat sections with air handler units, adjust the air handler speed according to the size of electric heat and air handler unit. See air flow chart section for speed adjustment procedures.

1. Set the thermostat above room temperature.
2. Check the heat pump and the heat section for normal operation.
3. Set the thermostat to desired setting.
4. Affix the wiring diagram sticker to front access door next to the unit wiring diagram.

IV-CONFIGURATION MODIFICATIONS

A-Upflow Application

1. The air handler must be supported on the bottom only and set on solid floor or field-supplied support frame. Securely attach the air handler to the floor or support frame.
2. If installing a unit in an upflow application, remove the horizontal drain pan. **IMPORTANT - The horizontal drain pan is not required in upflow air discharge installations; its removal provides the best efficiency and air flow.**
3. Place the unit in the desired location and slope unit as previously mentioned. Connect return and supply air plenums using sheet metal screws.
4. Install units that have no return air plenum on a stand that is at least 14" from the floor. This allows for proper air return.

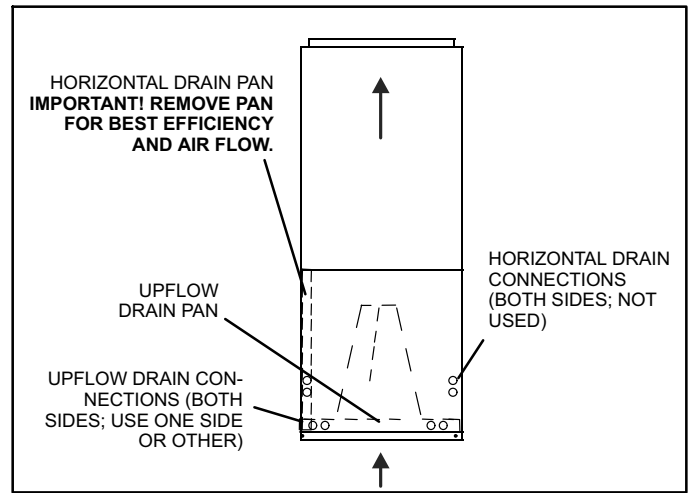

Figure 22. Upflow Configuration

B-Horizontal Application

⚠ WARNING

When removing the coil, there is possible danger of equipment damage and personal injury. Be careful when removing the coil assembly from a unit installed in right- or left-hand applications. The coil may tip into the drain pan once it is clear of the cabinet. Support the coil when removing it.

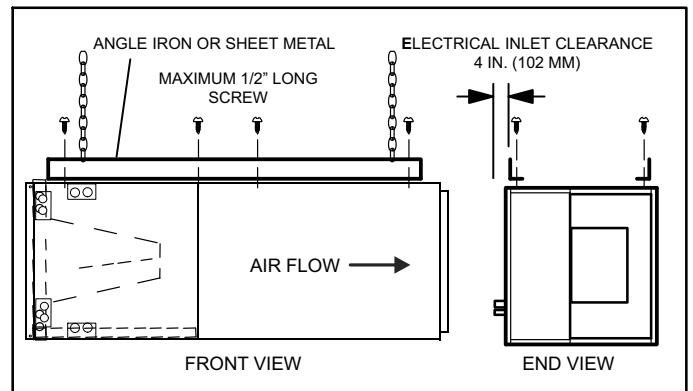

Figure 23. Suspending Horizontal Unit

NOTE — When the unit is installed in horizontal applications, a secondary drain pan is recommended. Refer to local codes.

NOTE — This unit may be installed in left-hand or right-hand air discharge horizontal applications. Adequate support must be provided to ensure cabinet integrity. Ensure that there is adequate room to remove service and access panels if installing in the horizontal position.

LEFT-HAND DISCHARGE

1. Determine knockouts required for drain line connections.
2. With access door removed, knock out drain line opening for installing drain lines.

- Set unit so that it is sloped toward the drain pan end of the unit (see figure 30).
- The horizontal configuration is shown in figure 24.

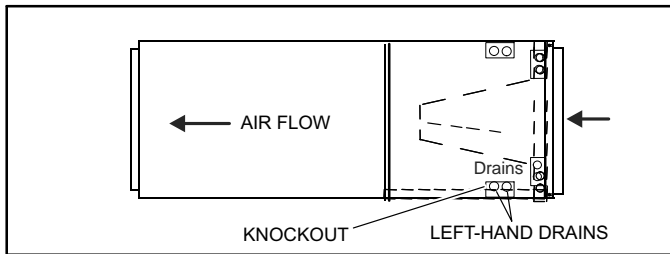

Figure 24. Left-Hand Discharge Configuration

- If the unit is suspended, the entire length of the cabinet must be supported. If you use a chain or strap, use a piece of angle iron or sheet metal attached to the unit (either above or below) to support the length of the cabinet. Use securing screws no longer than 1/2 inch to avoid damaging the coil or filter. See figure 23. Use sheet metal screws to connect the return and supply air plenums as required.

RIGHT-HAND AIR DISCHARGE

For horizontal right-hand air discharge, the following field modifications are required.

- Remove and set aside blower and coil access covers.
- Remove bracket(s) securing pan(s) to unit as illustrated in figures 25 and 26.

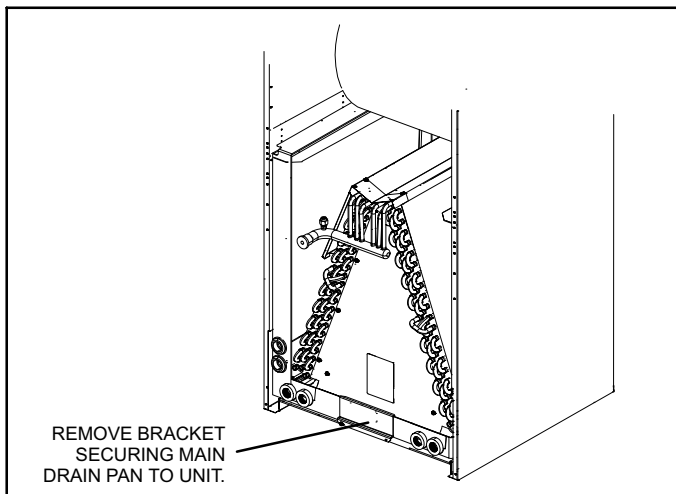

Figure 25. Remove Main Drain Pan Mounting Bracket (-018 through -036)

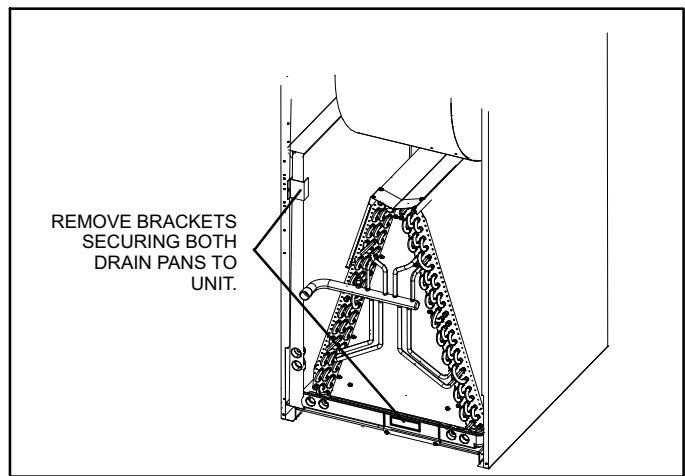

Figure 26. Remove Horizontal and Main Drain Pan Mounting Brackets (-042 through -060)

- Remove coil assembly, bottom drain pan and horizontal drain pan as one assembly from the air handler.
- Move the horizontal drain pan to the opposite side of the coil. Plug the drain holes located near the back of the unit. Remove the plugs from the front drain pan holes.
- Re-install modified coil/drain pan assembly in air handler in the same orientation as before (figures 27 and 28).

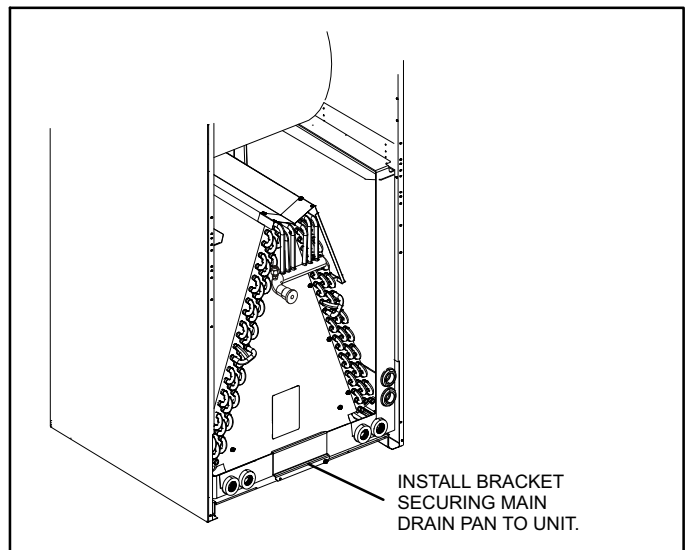

Figure 27. Install Main Drain Pan Mounting Bracket (-018 through -036)

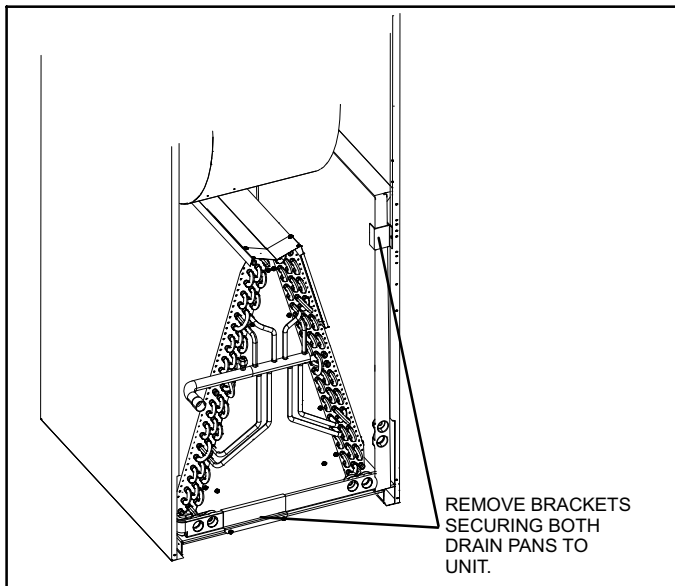

Figure 28. Install both Horizontal and Main Drain Pan Brackets (-042 through -060)

- Remove two screws securing the blow-off prevention bracket. Rotate the brackets 180° and reinstall using the same screws. See figure 29.

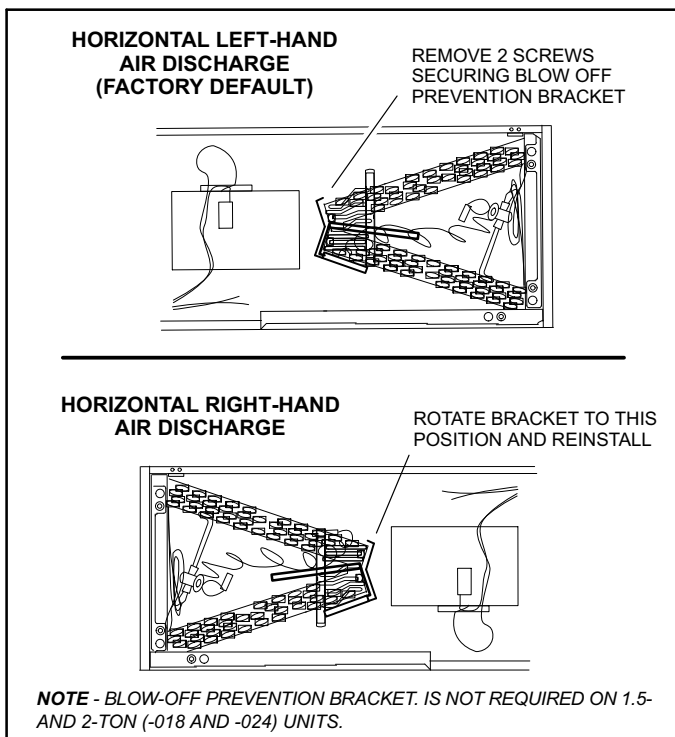

Figure 29. Blow-Off Prevention Plate

C-Condensate Drain

! IMPORTANT

On units of this type, where the blower “draws” rather than “blows” air through the coil, traps must be installed in the condensate drain lines (primary and auxiliary, if used). Traps prevent the blower from drawing air through the drain lines into the air supply.

! IMPORTANT

A field-fabricated secondary drain pan, with a drain pipe to the outside of the building, is required in all installations over a finished living space or in any area that may be damaged by overflow from the main drain pan. In some localities, local codes may require a secondary drain pan for any horizontal installation.

The air handler is provided with 3/4” NPT condensate drain connections.

SLOPING THE UNIT TOWARD THE DRAIN

Make sure the unit is sloped (similar to the slope shown in figure 30) (horizontal or upflow) so that the drain pan will empty completely without water standing in the pan.

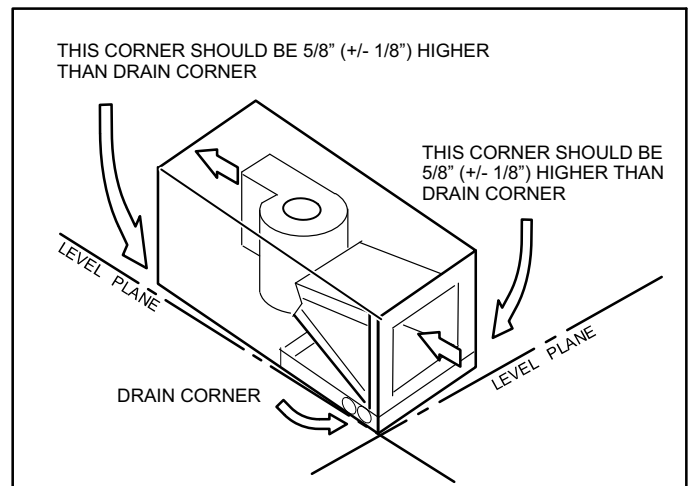

Figure 30. Sloping the Drain

INSTALL CONDENSATE DRAIN

The air handler is equipped with 3/4" NPT condensate drain connections.

! IMPORTANT

On some pans, the primary and secondary drain holes have knockouts.

Confirm primary and secondary drains are open.

1. **CB25UHV-018 through -036** units are equipped with a white drain pan, which includes green (main drain) and red (secondary drain) plugs. Unscrew the plugs to remove them before inserting condensate drain fittings.
2. **CB25UHV-042 through -60** units are equipped with a black drain pan equipped with drain knockouts. Use a flat-blade screwdriver to remove the 3/4" main drain and 3/8" secondary drain knockouts. Remove all rough edges before inserting condensate drain fittings.

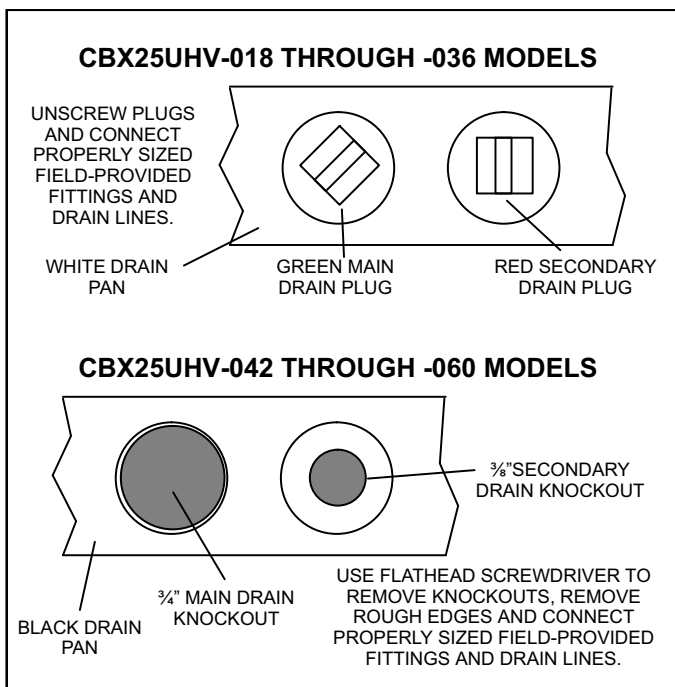

Figure 31. Drain Line Connections

3. Install properly sized, field-provided connection fittings and connect primary drain line to the main drain pan connection.

NOTE - When installing drain line connection fittings to the drain pan, hand tighten the fitting and use a thread sealant. Over-tightening the fittings can split connections on the drain pan.

4. If the secondary drain line is to be used, remove the plug or the knockout and route the drain line so that water draining from the outlet will be easily noticed by the homeowner. Refer to local codes for drain trap requirements on the secondary drain line.
5. Check again to ensure drain ports and drain pan are free of all debris.
6. Plug and check any unused drain pan openings for tightness. Torque plugs to 30 in. lb. to prevent water leaks or seepage from the drain pan.
7. Install a 2" trap in the main (primary) drain lines as close to the unit as practical (see figure 32). Make sure the top of the trap is below the connection to the drain pan to allow complete drainage of the pan.

NOTE - Horizontal runs must have an anti-siphon air vent (standpipe) installed ahead of the horizontal run. See figure 32. An extremely long horizontal run may require an oversized drain line to eliminate air traps.

NOTE - Do not operate air handler without a trap in the main (primary) drain. The condensate drain is on the negative pressure side of the blower; therefore, air being pulled through the condensate line will not allow positive drainage without a proper trap.

8. Route the drain line to the outside or to an appropriate drain. Drain lines must be installed so they do not block service access to the front of the air handler. A 24" clearance is required for filter, coil, or blower removal and service access.

NOTE - Check local codes before connecting the drain line to an existing drainage system.

Insulate the drain lines where sweating could cause water damage.

TEST CONDENSATE DRAIN

Test the drain pan and drain line after installation:

1. Pour several quarts of water into drain pan, enough to fill drain trap and line.
2. Check to make sure the drain pan is draining completely, no leaks are found in drain line fittings, and water is draining from the end of the primary drain line.
3. Correct any leaks found.

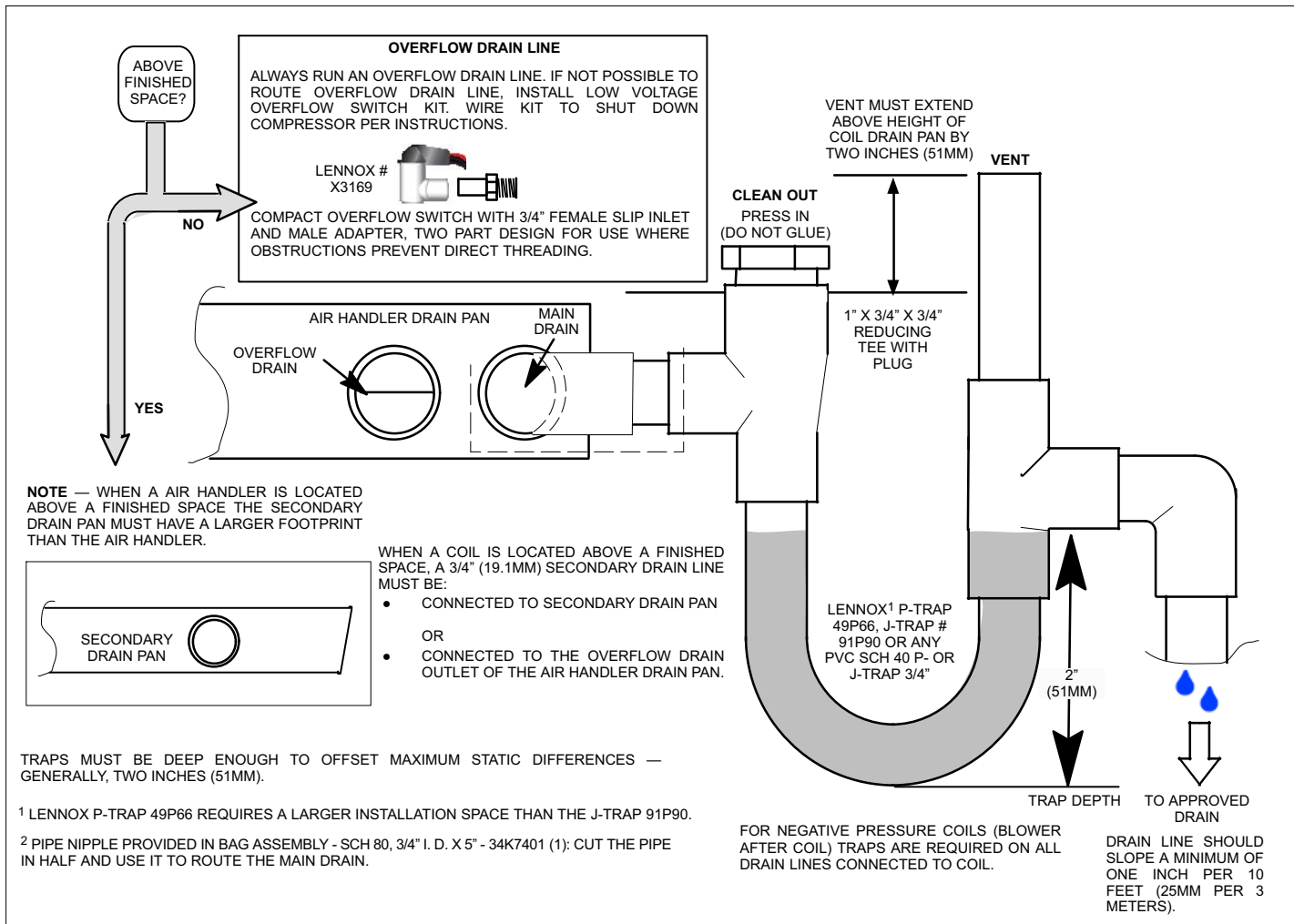

Figure 32. Typical Main and Overflow Drain

D-Duct System and Filters

DUCT SYSTEM

The air handler is provided with flanges for the connection of the supply plenum.

Supply and return duct system must be adequately sized to meet the system's air requirements and static pressure capabilities. The duct system should be insulated with a minimum of 1" thick insulation with a vapor barrier in conditioned areas or 2" minimum in unconditioned areas.

Supply plenum should be the same size as the flanged opening provided around the blower outlet and should extend at least 3 ft. from the air handler before turning or branching off plenum into duct runs. The plenum forms an extension of the blower housing and minimizes air expansion losses from the blower.

INSTALLING DUCT SYSTEM

Connect supply air plenum to the flange on top of the air handler. If an isolation connector is used, it must be nonflammable.

A return air duct system is recommended. If the unit is installed in a confined space or closet, a return connection must be run, full size, to a location outside the closet.

FIELD-FABRICATED RETURN AIR DUCT FLANGE FOR HORIZONTAL APPLICATIONS

A return air duct system is recommended, but not factory-provided. If the unit is installed in a confined space or closet, run a full-size return connection to a location outside the closet.

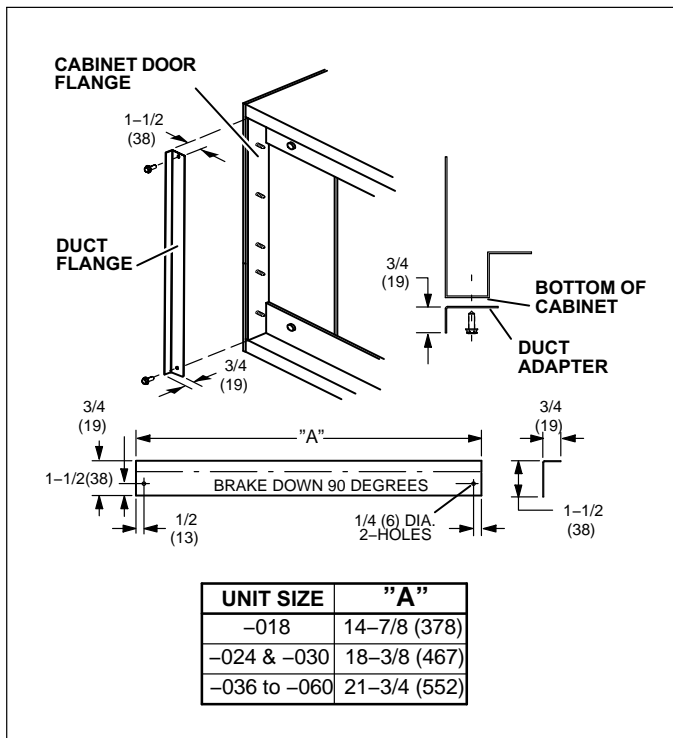

Figure 33. Cabinet and Duct Flange

E-Connecting Refrigerant Lines

Refrigerant lines must be connected by a qualified technician in accordance with established procedures.

! IMPORTANT

Refrigerant lines must be clean, dry, refrigerant-grade copper lines. Air handler coils should be installed only with specified line sizes for approved system combinations.

Handle the refrigerant lines gently during the installation process. Sharp bends or kinks in the lines will cause a restriction.

! WARNING

Polyol ester (POE) oils used with HFC-410A refrigerant absorb moisture very quickly. It is very important that the refrigerant system be kept closed as much as possible. DO NOT remove line set caps or service valve stub caps until you are ready to make connections.

! WARNING



Danger of fire. Bleeding the refrigerant charge from only the high side may result in the low side shell and suction tubing being pressurized. Application of a brazing torch while pressurized may result in ignition of the refrigerant and oil mixture - check the high and low pressures before unbrazing.

! WARNING



When using a high pressure gas such as dry nitrogen to pressurize a refrigeration or air conditioning system, use a regulator that can control the pressure down to 1 or 2 psig (6.9 to 13.8 kPa).

! CAUTION

Brazing alloys and flux contain materials which are hazardous to your health.

Avoid breathing vapors or fumes from brazing operations. Perform operations only in well ventilated areas.

Wear gloves and protective goggles or face shield to protect against burns.

Wash hands with soap and water after handling brazing alloys and flux.

IMPORTANT

To prevent the build-up of high levels of nitrogen when purging, be sure it is done in a well ventilated area. Purge low pressure nitrogen (1 to 2 psig) through the refrigerant piping during brazing. This will help to prevent oxidation and the introduction of moisture into a system.

NOTE - When installing refrigerant lines longer than 50 feet, see the *Lennox Refrigerant Piping Design and Fabrication Guidelines, CORP. 9351-L9*, or contact *Lennox Technical Support Product Applications* for assistance. To obtain the correct information from Lennox, be sure to communicate the following information:

1. Route the suction and liquid lines from the fittings on the indoor coil to the fittings on the outdoor unit. Run the lines in a direct path, avoiding unnecessary turns and bends.
2. Make sure that the suction line is insulated over the entire exposed length and that neither suction nor liquid lines are in direct contact with floors, walls, duct system, floor joists, or other piping.
3. Connect the suction and liquid lines to the evaporator coil. Take care to protect the cabinet and internal components as detailed in figure 34.
4. To avoid damaging the rubber grommets in the cabinet while brazing, slide the rubber grommets over the

refrigerant lines until they are away from the heat source.

5. Remove the expansion valve sensing bulb from its shipping location in the unit. Place it where it will be protected from the heat during brazing.
6. Braze using an alloy of silver or copper and phosphorus with a melting point above 1,100°F (593°C).

NOTE - Do not use soft solder.

7. Allow refrigerant pipes to cool to room temperature.
8. Re-install the expansion valve sensing bulb onto the suction line outside of the cabinet. See figure 35.

NOTE - Make sure to route copper refrigerant tubing away from sharp edges and make sure that it does not touch other metal surfaces. This prevents damage caused by vibration or metal-on-metal contact.

9. Insulate the sensing bulb once it is positioned outside of the cabinet.
10. Reinstall the rubber grommets into the refrigerant piping panel.

NOTE - Make sure expansion valve capillary tube is not touching metal edges or copper tubing.

11. Make sure outdoor unit has been placed according to the Installation Instructions and is connected to the refrigerant lines.

PLEASE READ IMPORTANT ISSUES CONCERNING BRAZING OPERATIONS ON PREVIOUS PAGES BEFORE PROCEEDING.

NOTE - REFER TO OUTDOOR UNIT INSTALLATION INSTRUCTIONS FOR REFRIGERANT PIPING SIZE REQUIREMENTS.

NOTE - Use silver alloy brazing rods with five or six percent minimum silver alloy for copper-to-copper brazing, 45 percent alloy for copper-to-brass and copper-to-steel brazing.

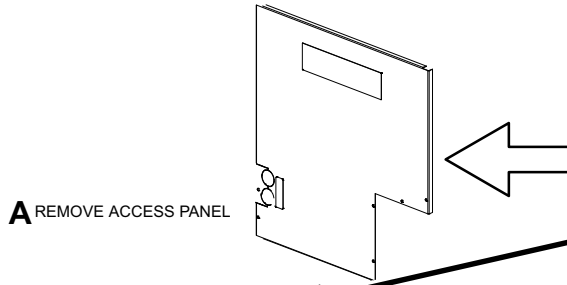
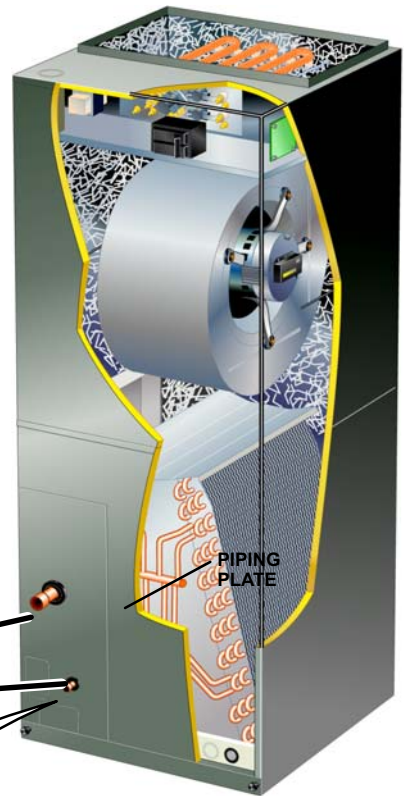

A REMOVE ACCESS PANEL

B REMOVE RUBBER PLUG FROM BOTH LIQUID AND SUCTION LINES
NOTE - CBX25MV SERIES UNITS USE NITROGEN OR DRY AIR AS A HOLDING CHARGE. IF THERE IS NO PRESSURE WHEN THE RUBBER PLUGS ARE REMOVED, CHECK THE COIL FOR LEAKS BEFORE INSTALLING.

C EITHER REMOVE OR PUSH PIPE WRAPPING BACK THROUGH HOLE IN PIPING PLATE BEFORE LINE SET CONNECTION AND BRAZING.

D CONNECT PIPES
NOTE - REFRIGERANT LINE SETS SHOULD BE ROUTED TO ALLOW FILTER ACCESSIBILITY.

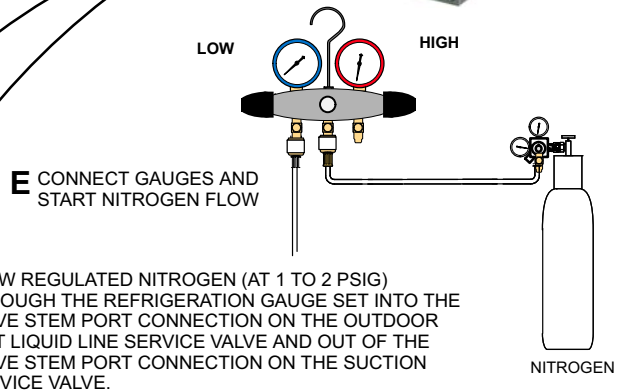
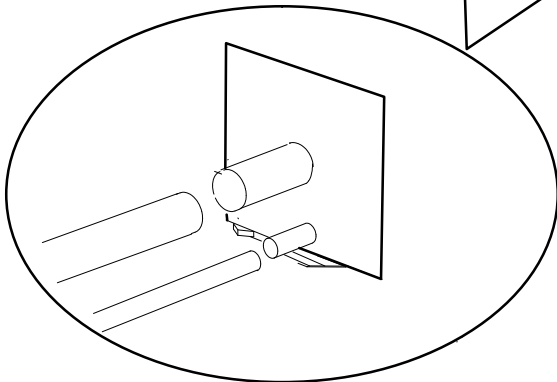

E CONNECT GAUGES AND START NITROGEN FLOW

FLOW REGULATED NITROGEN (AT 1 TO 2 PSIG) THROUGH THE REFRIGERATION GAUGE SET INTO THE VALVE STEM PORT CONNECTION ON THE OUTDOOR UNIT LIQUID LINE SERVICE VALVE AND OUT OF THE VALVE STEM PORT CONNECTION ON THE SUCTION SERVICE VALVE.

F PLACE A WET RAG AGAINST PIPING PLATE AND AROUND THE SUCTION LINE CONNECTION. A

G BRAZE CONNECTION. ALLOW PIPE TO COOL BEFORE REMOVING WET RAG FROM THERMOSTATIC EXPANSION VALVE WITH AN INTERNAL CHECK VALVE SENSING BULB AND PIPING PANEL AREA.

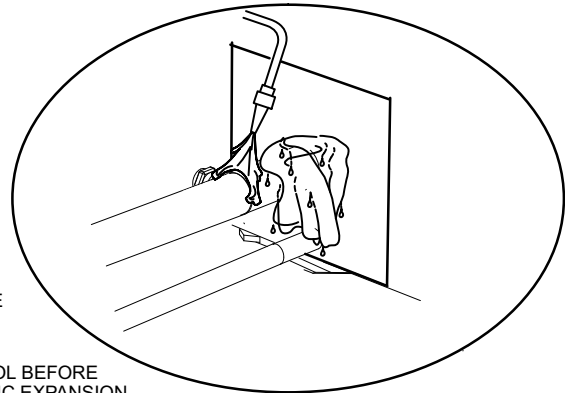

H REPEAT PREVIOUS PROCEDURE FOR LIQUID LINE.

REFER TO INSTRUCTIONS PROVIDED WITH OUTDOOR UNIT FOR LEAK TESTING, EVACUATING AND CHARGING PROCEDURES

Figure 34. Brazing Connections

Step 1. Remove unit access panels.



REMOVE
ACCESS
PANELS

Step 2. Locate and remove TEV sensing bulb from factory location.

TEV SENSING
BULB FACTORY
LOCATION



Step 3. Relocate TEV sensing bulb to external suction line.

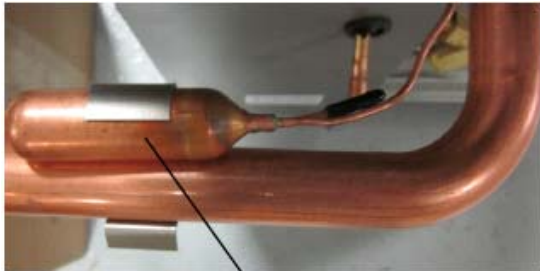

NEW LOCATION (OUTSIDE OF CABINET)

Step 4. Properly position TEV sensing bulb on suction line and fasten bulb to line.

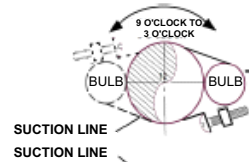

ON LINES SMALLER THAN $\frac{7}{8}$ "
INSTALL THE SENSING BULB
BETWEEN THE 9 O'CLOCK
AND 3 O'CLOCK POSITIONS.

SUCTION LINE
SUCTION LINE

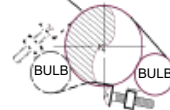

ON LINES $\frac{7}{8}$ " AND LARGER IN DIA-
METER, INSTALL THE SENSING BULB
IN EITHER THE 4 O'CLOCK
OR 8 O'CLOCK POSITION. NEVER
INSTALL THE SENSING BULB ON
THE BOTTOM OF THE LINE.

NOTE - Never install the sensing bulb on the bottom of the line.

Step 5. Apply insulation over the suction line and TEV sensing bulb. Use tape or cable ties to secure the insulation.



NOTE - Route copper away from sharp edges. Make sure that copper refrigerant lines do not touch other metal surfaces (end plates, brazed connections, etc.). Metal-to-metal contact may transfer vibration or cause damage.



Figure 35. Relocating Expansion Valve Sensing Bulb

F-Sealing the Unit

Seal the unit so that warm air is not allowed into the cabinet. Warm air introduces moisture, which results in water blow-off problems. This is especially important when the unit is installed in an unconditioned area.

If installed in an unconditioned space, sealant should be applied around the electrical wires, refrigerant tubing, and condensate lines where they enter the cabinet.

WARNING

There must be an airtight seal between the bottom of the air handler and the return air plenum. Use fiberglass sealing strips, caulking, or equivalent sealing method between the plenum and the air handler cabinet to ensure a tight seal. Return air must not be drawn from a room where this air handler or any gas-fueled appliance (i.e., water heater), or carbon monoxide-producing device (i.e., wood fireplace) is installed.

IMPORTANT

When sealing the cabinet, be sure to seal closed any space around the holes where the drain lines exit the cabinet using duct tape and/or Permagum. Warm air must not be allowed to enter through any gaps or holes in the cabinet.

Make sure the liquid line and suction line entry points are sealed with either ARMAFLEX material or with Permagum. Permagum may also be used to seal around the main and auxiliary drains and around open areas of electrical inlets.

V-ELECTRICAL CONNECTIONS

WARNING



Electric shock hazard! Can cause injury or death.

Disconnect all power supplies before servicing.

Replace all parts and panels before operating.

Failure to do so can result in death or electrical shock.

WARNING



Electric shock hazard! Can cause injury or death.

Unit must be grounded in accordance with national and local codes. Connect ground wire to ground terminal marked "GND".

Line voltage is present at all components when unit is not in operation on units with single-pole contactors. Disconnect all remote electric power supplies before opening access panel. Unit may have multiple power supplies.

WARNING

Electric Shock Hazard.

Can cause injury or death.

Foil-faced insulation has conductive characteristics similar to metal. Be sure there are no electrical connections within a 1/2" of the insulation. If the foil-faced insulation comes in contact with electrical voltage, the foil could provide a path for current to pass through to the outer metal cabinet. While the current produced may not be enough to trip existing electrical safety devices (e.g. fuses or circuit breakers), the current can be enough to cause an electric shock hazard that could cause personal injury or death.

- All field wiring must be done in accordance with National Electrical Code, applicable requirements of UL and local codes, where applicable.
- Electrical wiring, disconnect means and over-current protection are to be supplied by the installer. Refer to the air handler rating plate for maximum over-current protection, minimum circuit ampacity, as well as operating voltage.
- The power supply must be sized and protected according to the specifications supplied on the product.
- This air handler is factory-configured for 240 volt, single phase, 60 cycles. For 208-volt applications, see "208 Volt Conversion" later in this section.
- For optional field-installed electric heat applications, refer to the instructions provided with the accessory for proper installation.



WARNING

USE COPPER CONDUCTORS ONLY

1. Disconnect all power supplies.
2. Remove the air handler access panel.
3. Route the field supply wires to the air handler electrical connection box.
4. Use UL-listed wire nuts to connect the field supply conductors to the unit black and yellow leads, and the ground wire to ground terminal marked **GND**.
5. Replace the air handler access panel.

208 VOLT CONVERSION

1. Disconnect all power supplies.
2. Remove the air handler access panel.
3. Using the wiring diagram located on the unit access panel as a reference, move the black transformer leads from the 240-volt terminal on the transformer to the 208-volt terminal on the transformer.
See figure 36.

208 / 240 VOLT TRANSFORMER

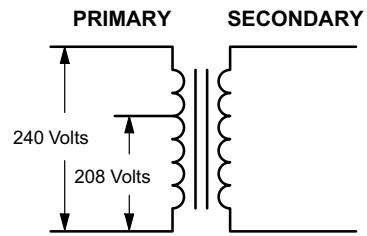

**Figure 36. Converting Unit from 240 VAC to 208 VAC
POWER UP — LINE VOLTAGE**

With Electric Heat — 240VAC line voltage power is supplied from the circuit breaker to the **heat strips and control section** via the 6-pin plug. (terminals 1 and 2).

Without Electric Heat — 240VAC line voltage is supplied from the black and yellow wires from the 6-pin plug to the **control section**.

Blower Motor — 240VAC is supplied to the blower motor through pins 4 and 5 of the 5-pin plug.

NOTE - Blower relay coil is energized when SEQ1 relay normally open contacts (4 to 5) close.

Transformer — 240VAC is supplied to the transformer primary from L1 and L2.

VI-WIRING DIAGRAM

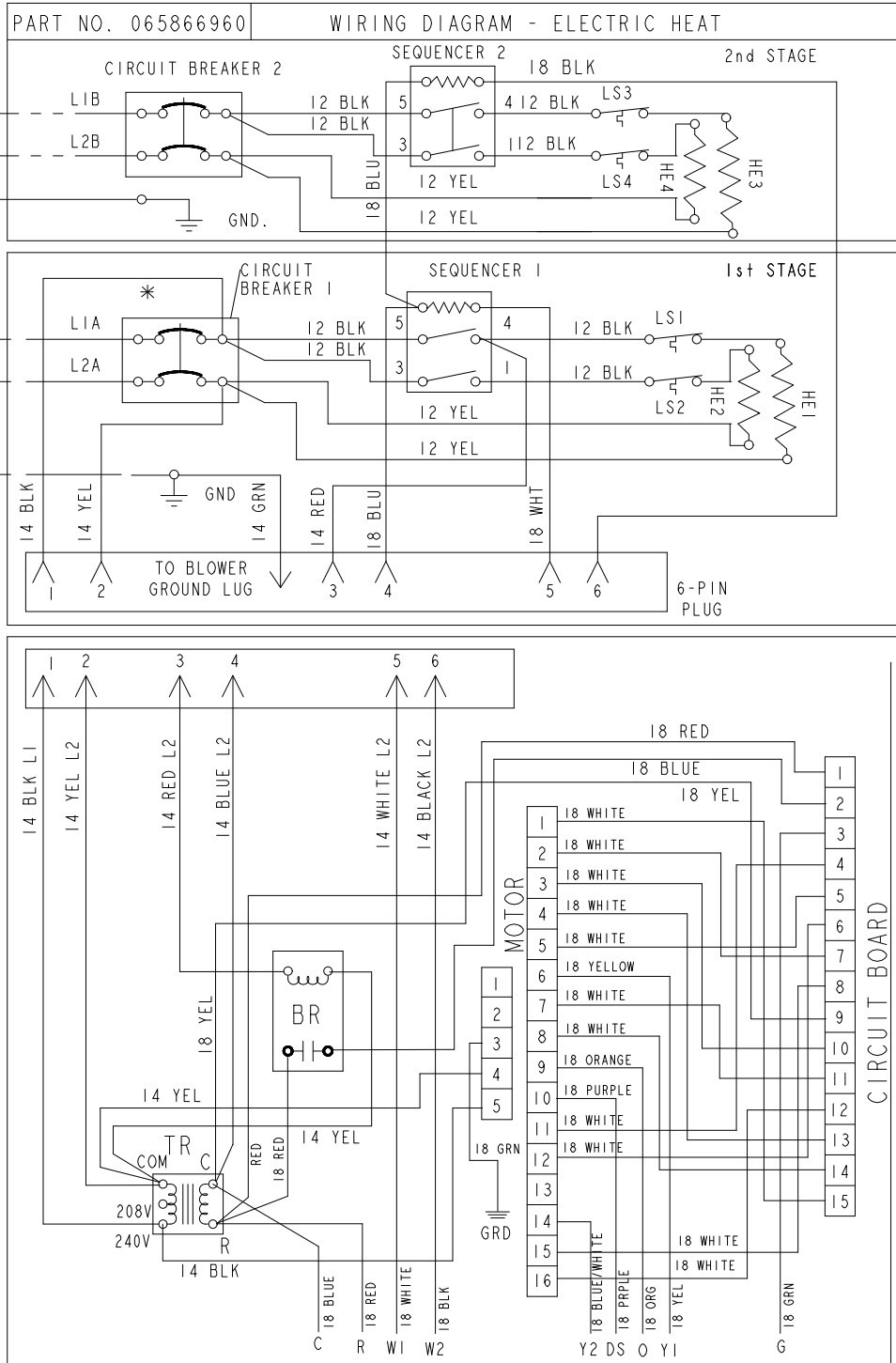

HEATERS USED

- 5 KW = HE1
- 7.5 & 10 KW = HE1 & HE2
- 15 KW = HE1, HE2 & HE3
- 20 KW = HE1, HE2, HE3 & HE4

- * TB = TERMINAL BLOCK (OPT.)
- * CB = CIRCUIT BREAKER (OPT.)
- SEQ = SEQUENCER
- GND = GROUND LUG
- LS = LIMIT SWITCH
- HE = HEATER ELEMENT

- POWER (FACTORY WIRED) _____
- POWER (FIELD WIRED) _____
- CONTROL (FACTORY WIRED) _____
- CONTROL (FIELD WIRED) _____

CONTROL CIRCUIT WIRING TO BE 24 VOLT, N.E.C. CLASS 2

PLUG PIN LOCATION AMP 350781-1 6-PIN CAP

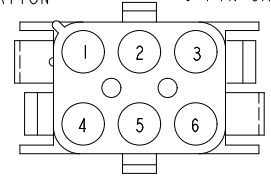

- TR = TRANSFORMER
- BR = BLOWER RELAY
- MTR = BLOWER MOTOR
- GND = GROUND CONNECTION

WIRING DIAGRAM: NO HEAT

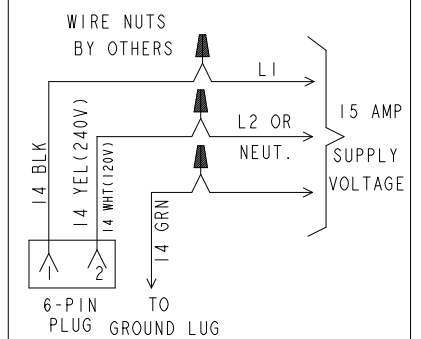
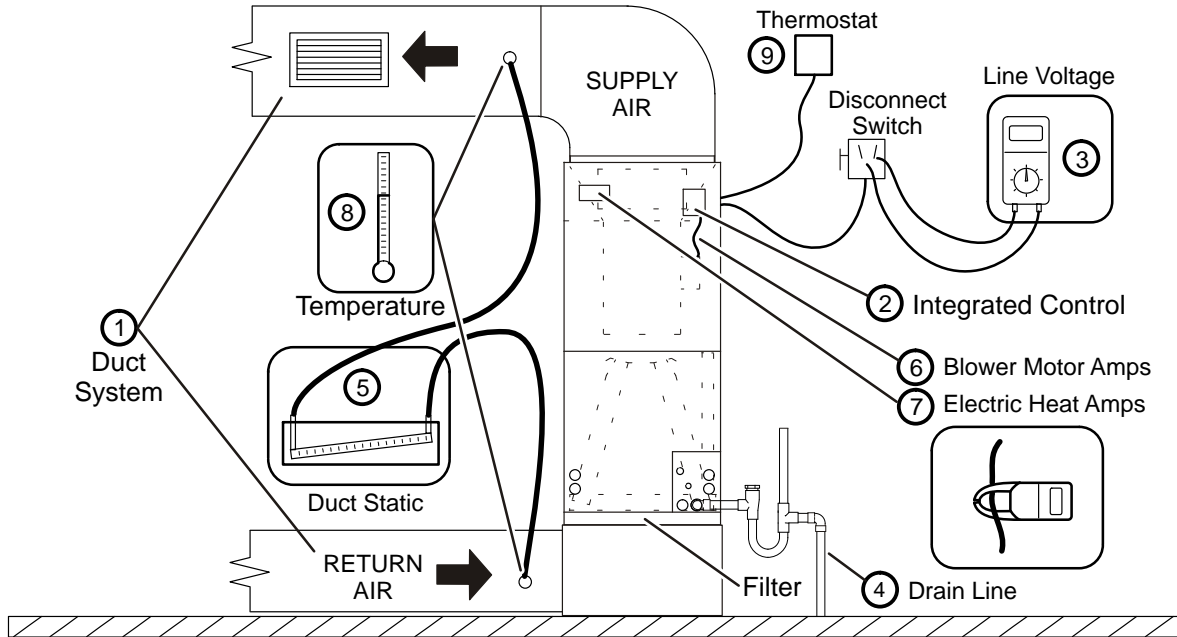

Figure 37. Low Voltage Connections (Variable-Speed Motor) - Field Wiring

VII-PERFORMANCE CHECKLISTS

Installing Contractor's Name _____ Installing Date _____
 Installing Contractor's Phone _____ Air Handler Model # _____
 Job Address _____



- | | |
|---|---|
| <p>① DUCT SYSTEM</p> <p>SUPPLY AIR DUCT</p> <p><input type="checkbox"/> Sealed</p> <p><input type="checkbox"/> Insulated (if necessary)</p> <p><input type="checkbox"/> Registers Open and Unobstructed</p> <p>RETURN AIR DUCT</p> <p><input type="checkbox"/> Sealed</p> <p><input type="checkbox"/> Filter Installed and Clean</p> <p><input type="checkbox"/> Registers Open and Unobstructed</p> <p>② INTEGRATED CONTROL</p> <p><input type="checkbox"/> Jumpers Configured Correctly (if applicable)</p> <p><input type="checkbox"/> Appropriate Links in Place (if applicable)</p> <p>③ VOLTAGE CHECK</p> <p><input type="checkbox"/> Supply Voltage _____</p> <p><input type="checkbox"/> Low Voltage _____</p> <p><input type="checkbox"/> Electrical Connections Tight</p> <p>④ DRAIN LINE</p> <p><input type="checkbox"/> Leak Free</p>
<p><input type="checkbox"/> Explained Operation of System to Homeowner</p> | <p>⑤ TOTAL EXTERNAL STATIC (dry coil)</p> <p style="text-align: right;">dry coil wet coil</p> <p>Supply External Static _____</p> <p>Return External Static _____</p> <p>Total External Static = _____</p> <p>⑥ ELECTRIC HEAT AMPS _____</p> <p>⑦ INDOOR BLOWER AMPS _____</p> <p>INDOOR BLOWER CFM _____</p> <p>⑧ TEMPERATURE DROP (Cooling Mode)</p> <p>Return Duct Temperature _____</p> <p>Supply Duct Temperature - _____</p> <p>Temperature Drop = _____</p> <p>⑧ TEMPERATURE RISE (Heating Mode)</p> <p>Return Duct Temperature _____</p> <p>Supply Duct Temperature - _____</p> <p>Temperature Rise = _____</p> <p>⑨ THERMOSTAT</p> <p><input type="checkbox"/> Adjusted and Programmed</p> <p><input type="checkbox"/> Operation Explained to Owner</p> |
|---|---|

Technician's Name: _____ Date Start-Up & Performance Check Completed _____

Figure 38. Start-Up and Performance Checklist (Upflow Configuration)

Installing Contractor's Name _____ Installing Date _____

Installing Contractor's Phone _____ Air Handler Model # _____

Job Address _____

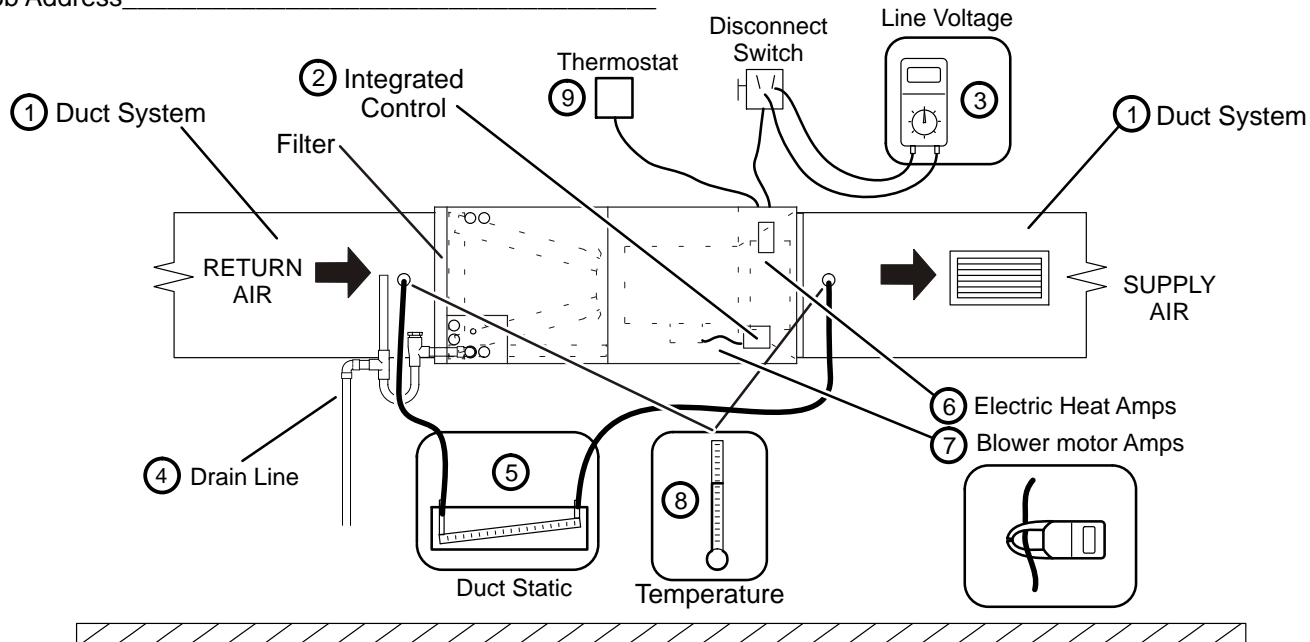

- | | | | | | | | | | | | | | |
|---|--|----------|----------|----------|------------------------|-------|-------|------------------------|-------|-------|-------------------------|-------|-------|
| <p>① DUCT SYSTEM
 SUPPLY AIR DUCT</p> <p><input type="checkbox"/> Sealed</p> <p><input type="checkbox"/> Insulated (if necessary)</p> <p><input type="checkbox"/> Registers Open and Unobstructed</p> <p>RETURN AIR DUCT</p> <p><input type="checkbox"/> Sealed</p> <p><input type="checkbox"/> Filter Installed and Clean</p> <p><input type="checkbox"/> Registers Open and Unobstructed</p> <p>② INTEGRATED CONTROL</p> <p><input type="checkbox"/> Jumpers Configured Correctly (if applicable)</p> <p><input type="checkbox"/> Appropriate Links in Place (if applicable)</p> <p>③ VOLTAGE CHECK</p> <p><input type="checkbox"/> Supply Voltage _____</p> <p><input type="checkbox"/> Low Voltage _____</p> <p><input type="checkbox"/> Electrical Connections Tight</p> <p>④ DRAIN LINE</p> <p><input type="checkbox"/> Leak Free</p> | <p>⑤ TOTAL EXTERNAL STATIC (dry coil)</p> <table border="0"> <tr> <td></td> <td style="text-align: right;">dry coil</td> <td style="text-align: right;">wet coil</td> </tr> <tr> <td>Supply External Static</td> <td style="text-align: right;">_____</td> <td style="text-align: right;">_____</td> </tr> <tr> <td>Return External Static</td> <td style="text-align: right;">_____</td> <td style="text-align: right;">_____</td> </tr> <tr> <td>Total External Static =</td> <td style="text-align: right;">_____</td> <td style="text-align: right;">_____</td> </tr> </table> <p>⑥ ELECTRIC HEAT AMPS _____</p> <p>⑦ INDOOR BLOWER AMPS _____</p> <p>INDOOR BLOWER CFM _____</p> <p>⑧ TEMPERATURE DROP (Cooling Mode)</p> <p>Return Duct Temperature _____</p> <p>Supply Duct Temperature - _____</p> <p>Temperature Drop = _____</p> <p>⑧ TEMPERATURE RISE (Heating Mode)</p> <p>Return Duct Temperature _____</p> <p>Supply Duct Temperature - _____</p> <p>Temperature Rise = _____</p> <p>⑨ THERMOSTAT</p> <p><input type="checkbox"/> Adjusted and Programmed</p> <p><input type="checkbox"/> Operation Explained to Owner</p> | | dry coil | wet coil | Supply External Static | _____ | _____ | Return External Static | _____ | _____ | Total External Static = | _____ | _____ |
| | dry coil | wet coil | | | | | | | | | | | |
| Supply External Static | _____ | _____ | | | | | | | | | | | |
| Return External Static | _____ | _____ | | | | | | | | | | | |
| Total External Static = | _____ | _____ | | | | | | | | | | | |

Explained Operation of System to Homeowner

Technician's Name: _____ Date Start-Up & Performance Check Completed _____

Figure 39. Start-Up and Performance Checklist (Horizontal Configuration)

VIII-SEQUENCE OF OPERATIONS

Heat Pump Heating — On a call for heat pump heating, the room thermostat sends a 24VAC signal from terminal **Y1** to **pin 6** on the blower motor (a field-provided jumper connects terminals **Y1** and **Y2** on the air handler). The green wire from the air handler terminal **G** carries a 24VAC signal to **pin 3** of the circuit board.

The blower motor cycles on at the selected heat pump heating speed. The **Y1** terminal on the room thermostat is connected to the **Y** terminal in the outdoor unit. The air handler **C** (Common) terminal is connected to terminal **C** in the outdoor units. The contactor closes to bring on the compressor and outdoor fan motor.

Cooling — On a call for cooling, the room thermostat sends a 24 volt signal from terminal **Y1** to pin 6 on the blower motor (a field-provided jumper connects terminals **Y1** and **Y2** on the air handler). A field-installed jumper between air handler terminals **R** and **O** supplies a 24VAC signal from the air handler **O** terminal to blower motor pin 9. The green wire from air handler terminal **G** carries a 24VAC signal to pin 3 of the circuit board.

The blower motor cycles on at the selected cooling blower speed. The **Y1** terminal on the room thermostat is connected to the **Y** terminal on the outdoor unit. The air handler **C** (Common) terminal is connected to terminal **C** in the outdoor unit. The contactor in the outdoor closes to bring on the compressor and outdoor fan motor.

Heating -- First-Stage Electric Heat with Conventional Thermostat — On a call for heating, the room thermostat sends a 24VAC signal to the air handler terminal **W1**.

The wire from **W1** to terminal 5 on the 5-pin plug energizes the coil in sequencer relay SEQ1.

If limit switches LS1 and LS2 are closed, sequencer relay (SEQ1) normally open contacts 4 and 5 and 1 and 3 close after a time delay to energize heating elements HE1 and HE2.

The wire from SEQ1 terminal 5 carries 240VAC power to pin 3 on the 6-pin plug to energize the blower relay coil.

The blower relay contacts close immediately to provide 24VAC power to terminal 2 on the circuit board.

A heating blower demand is sent from circuit board terminal 7 to pin 2 (W/W1) on the 16-pin plug on the blower motor.

The indoor blower is energized on the heating speed.

Heating -- Second-Stage Electric Heat with Conventional Thermostat — On a call for second-stage heating, the room thermostat sends a 24VAC signal to the air handler terminal **W2**.

The wire from **W2** to terminal 6 on the 6-pin plug energizes the coil in the sequencer relay SEQ2.

If limit switches LS3 and LS4 are closed, sequencer relay SEQ2 normally open contacts 4 and 5 and 1 and 3 close after a time delay to energize heating elements HE3 and HE4.