



MINI-SPLIT SYSTEMS SERVICE MANUAL

MHA Series Diagnostic Information

CORP1914-L8

10/2019

Please refer to Corp1913-L8 for indoor and outdoor unit information.

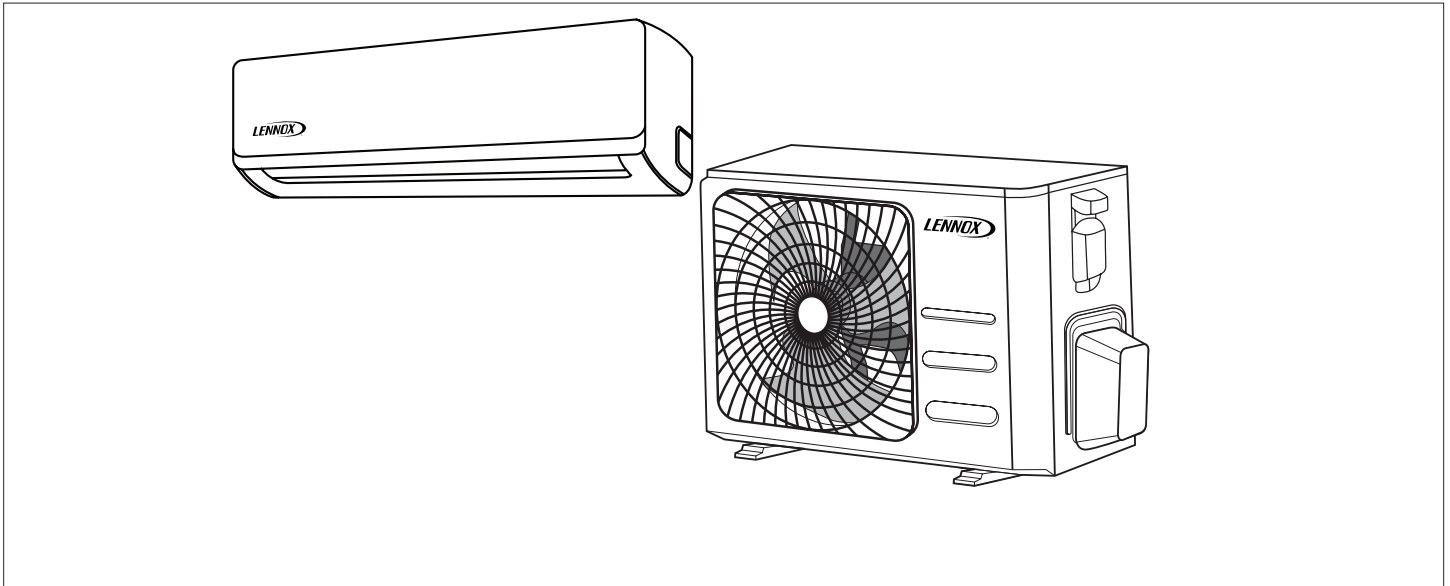

Table of Contents

1. Indoor / Outdoor Unit Error Codes	2	6. Pressure on Service Port (R-410A)....	19
2. Troubleshooting by Error Codes	3		
2.1. Temperature Sensor Check	3		
2.2. Compressor Checking	3		
2.3. IPM Continuity Check	4		
2.4. Normal P Voltage	4		
3. Error Codes.....	5		
3.1. Error Code: E0/F4.....	5		
3.2. Error Code: E1	6		
3.3. Error Code: E2	8		
3.4. Error Code: E3/E5	9		
3.5. Error Codes: E4, E5, F1, F2 and F3.....	11		
3.6. Error Code: EC	12		
3.7. Error Codes: P0.....	13		
3.8. Error Code: P1.....	14		
3.9. Error Code: P2.....	15		
3.10. Error Code: P4.....	16		
4. Temperature Sensor Resistance Values	17		
5. Discharge Temperature Sensor Resistance Values	18		

WARNING

Improper installation, adjustment, alteration, service or maintenance can cause property damage, personal injury or loss of life.

Installation and service must be performed by a licensed professional HVAC installer (or equivalent) or service agency

1. Indoor / Outdoor Unit Error Codes

For a list of applicable error codes for the indoor units, refer to “3. Error Codes” on page 5. All indoor units provide error code information with either a digital LED display or with Flash codes.

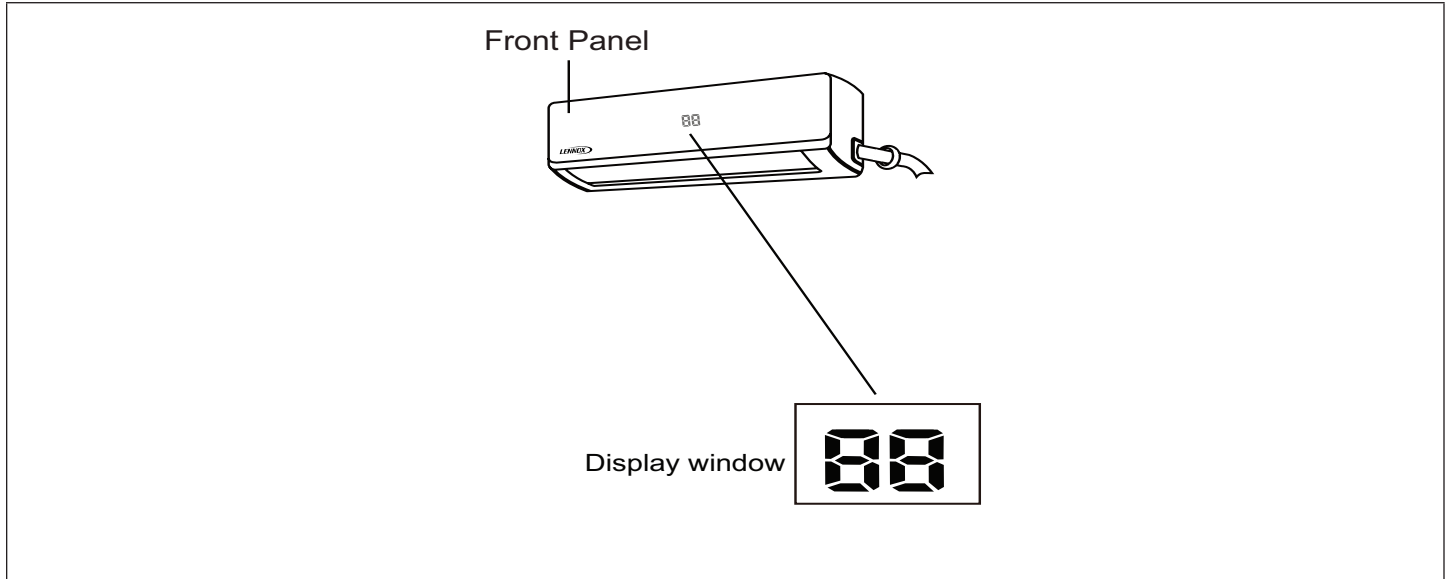

Figure 1. Indoor Unit Display

Indoor and Outdoor Unit Error Codes				
Outdoor Unit LED	Outdoor Unit LED Sequence	Indoor Unit Display	Error Information	Page Location
1 time	OFF	E0	Indoor unit EEPROM parameter error.	5
2 times	OFF	E1	Indoor / outdoor units communication error.	6
3 times	OFF	E2	Zero-crossing signal detection error.	8
4 times	OFF	E3	The indoor fan speed is operating outside of the normal range.	9
5 times	OFF	E4	Indoor room temperature sensor T1 is in open circuit or has short circuited	11
6 times	OFF	E5	Evaporator coil temperature sensor T2 is in open circuit or has short circuited.	11
7 times	OFF	EC	Refrigerant leak detected.	12
1 times	ON	F0	Overload current protection.	11
2 times	ON	F1	Outdoor ambient temperature sensor T4 open circuit or short circuit.	11
3 times	ON	F2	Condenser coil temperature sensor T3 is in open circuit or has short circuited.	11
4 times	ON	F3	Compressor discharge temperature sensor TP open circuit or short circuit.	11
5 times	ON	F4	Outdoor unit EEPROM parameter error.	5
6 times	ON	F5	The outdoor fan speed is operating outside of the normal range.	9
1 times	FLASH	p0	IPM malfunction or IGBT over-strong current protection.	13
2 times	FLASH	p1	Over voltage or over low voltage protection.	14
3 times	FLASH	p2	High temperature protection of IPM module.	15
5 times	FLASH	p4	Inverter compressor drive error.	16

2. Troubleshooting by Error Codes

2.1. Temperature Sensor Check

Disconnect the temperature sensor from PCB, measure the resistance value with a tester. Temperature Sensors.

- Room temperature (T1) sensor,
- Indoor coil temperature(T2) sensor,
- Outdoor coil temperature (T3) sensor,
- Outdoor ambient temperature (T4) sensor,
- Discharge temperature (T5) or (TP) sensor.

Measure the resistance value of each winding by using the multi-meter.

2.2. Compressor Checking

Measure the resistance value of each winding by using the tester

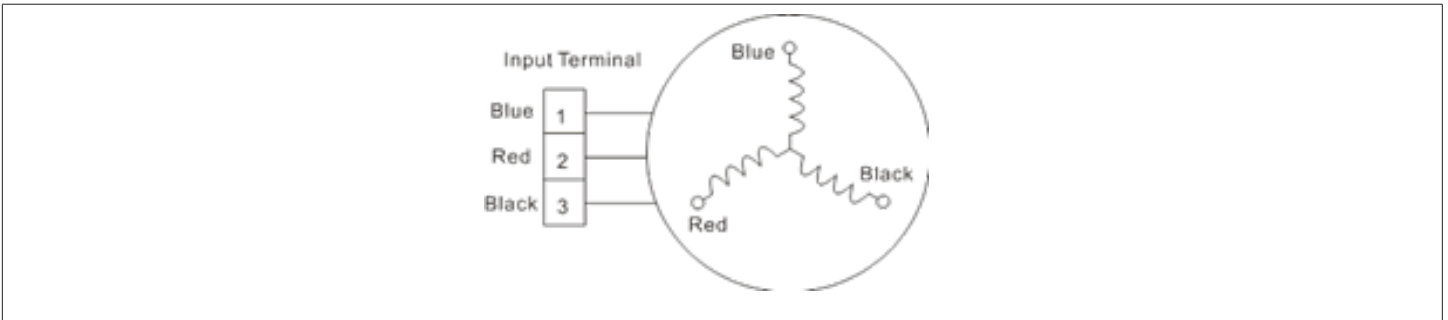

Figure 2. Input Terminal

Table 1. Compressor Terminal Resistance

Position	Resistance Value			
	ASN98D22UFZ	ASK89D29UEZD	ASN140D21UFZ	ATF235D22UMT
Blue - Red	1.57Ω (20°C/68°F)	1.99Ω (20°C/68°F)	1.28Ω (20°C/68°F)	0.75Ω (20°C/68°F)
Blue - Black				
Red - Blue				



2.3. IPM Continuity Check

Turn off the power, let the large capacity electrolytic capacitors discharge completely, and dismount the IPM. Use a digital tester to measure the resistance between P and UVWN; UVW and N.

Digital Tester		Normal Resistance Value	Digital Tester		Normal Resistance Value
(+) Red	(-) Black		(+) Red	(-) Black	
P	N	∞ (Several M Λ)	U	N	∞ (Several M Λ)
	U		V		
	V		W		
	W		(+) Red		

2.4. Normal P Voltage

Normal Voltage for P and N		
208-240V (1-phase))		
In Standby		
Around 310VDC		
In Operation		
With passive PFC module	With partial active PFC module	With fully active PFC module
>200VDC	>310VDC	>370VDC

3. Error Codes

3.1. Error Code: E0/F4

Description: Indoor or outdoor PCB main chip does not receive feedback from EEPROM chip.

General Note: Outdoor unit main control board chip is not receiving feedback from EEPROM chip.

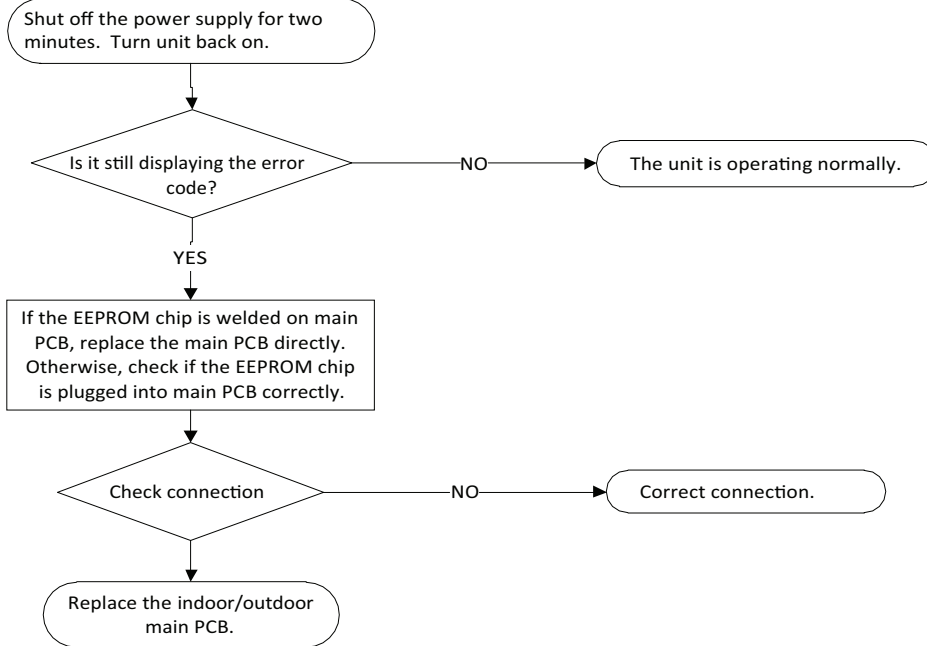

Remarks:

The location of the EEPROM chip on the indoor and outdoor PCB is shown in the following two images:

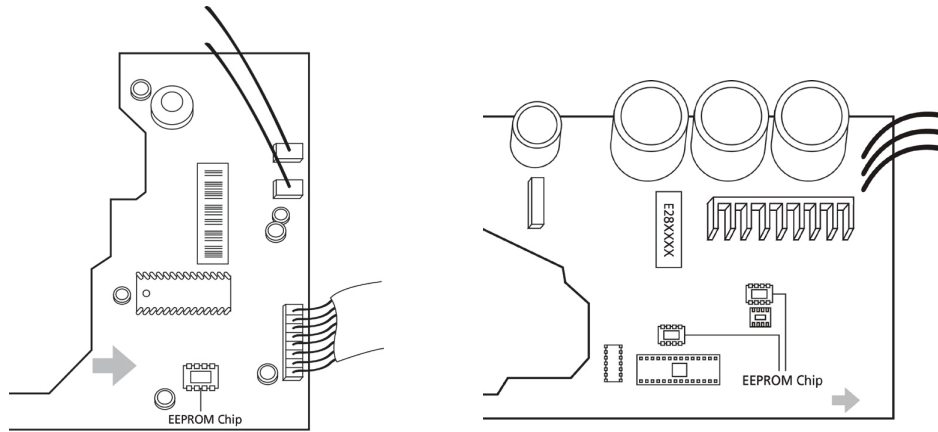

3.2. Error Code: E1

Description:	Communication malfunction between outdoor unit and all indoor units.
General Note:	The indoor unit has not received feedback from the outdoor unit for 110 seconds, four consecutive times

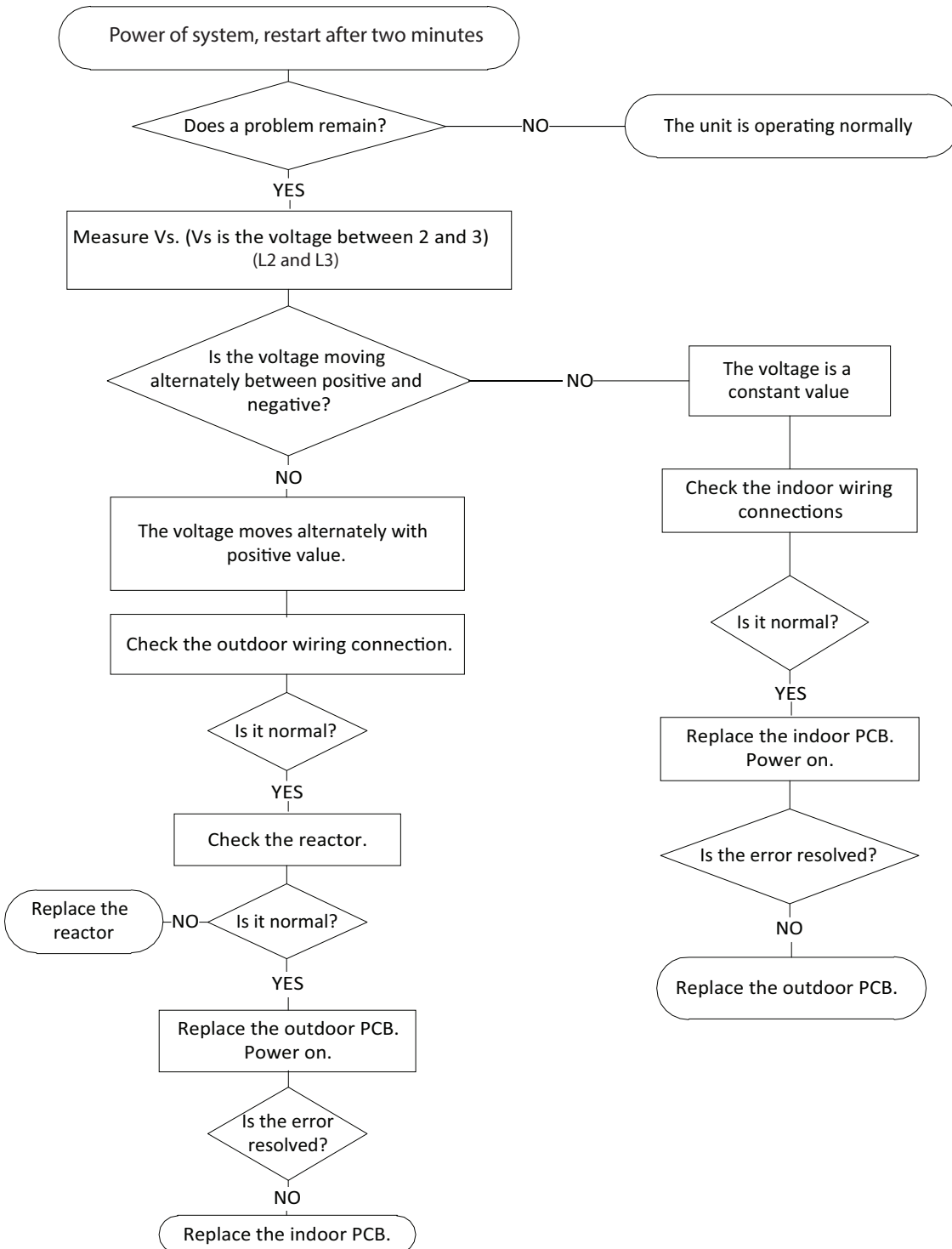

Error Code: E1 (continued)

Remarks:

Use a multimeter to test the DC voltage between terminals 2 and 32 on outdoor unit. The multimeter red probe connects to terminal 2 and the black probe connects to terminal 3.

When AC is running normally, the voltage will move alternately between -25V to 25V.

If the outdoor unit malfunctions, the voltage will move alternately with positive values.

If indoor units has malfunction, the voltage will be a variable.

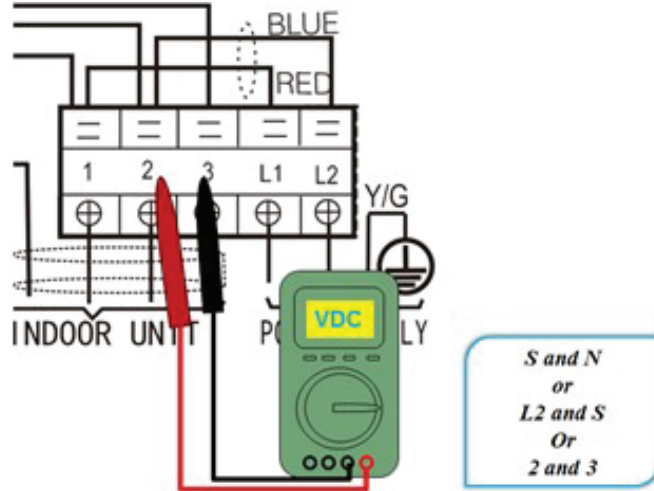

Use amultimeter to test the resistance of the reactor which does not connect to capacitor. The normal value should be around zero ohm. If not, the reactor is faulty and requires replacement.



3.3. Error Code: E2

Description: Zero crossing detection error diagnosis and solution

General Note: When PCB does not receive zero crossing signal feedback for 4 minutes or the zero crossing signal time interval is abnormal.

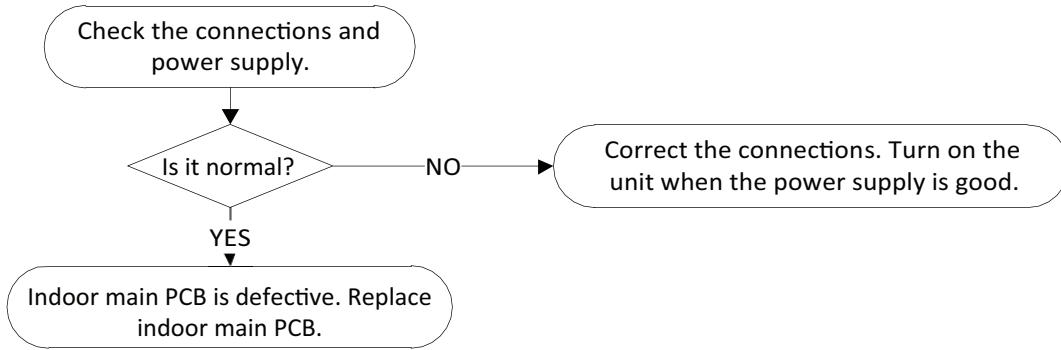

3.4. Error Code: E3/F5

Description: Fan Speed is Operating Outside of the Normal Range.

General Note: When the indoor fan speed is too low (300 RPM) during normal operations, the unit will stop and the LED will display the failure (E3). When the outdoor fan speed registers below 200 RPM or over 1500 RPM for an extended period of time, the unit will stop and the LED will display the failure (F5).

Power off, then restart the unit after 2 minutes.

Does a problem remain? — NO

YES

Shut off the power supply, rotate the fan by hand.

Does it turn easily? — NO

Find the cause of the problem and resolve it

YES

Check the wiring of fan motor.

Is it improperly wired? —

Ensure proper connections

YES

Measure the voltage for the fan motor from the PCB.

Is it within normal parameters? — NO

Replace the indoor/outdoor PCB

YES

Replace the fan motor

1. Indoor or Outdoor DC Fan Motor(control chip is in fan motor)

Power on and when the unit is in standby, measure the voltage of pin1-pin3, pin4-pin3 in fan motor connector. If the value of the voltage is not in the range showing in below table, the PCB must has problems and need to be replaced.

- DC motor voltage input and output (voltage: 220-240V~):

No.	Color	Signal	Voltage
1	Red	Vs/Vm	280V~380V
2	---	---	---
3	Black	GND	0V
4	White	Vcc	14-17.5V
5	Yellow	Vsp	0~5.6V
6	Blue	FG	14-17.5V

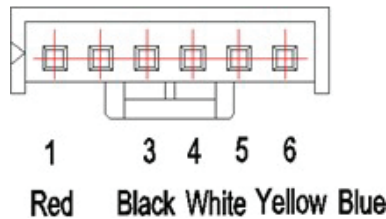

2. Outdoor DC Fan Motor (control chip is in outdoor PCB)

Release the UVW connector. Measure the resistance of U-V, U-W, V-W. If the resistance is not equal to each other, the fan motor must has problems and need to be replaced. otherwise the PCB must has problems and need to be replaced.

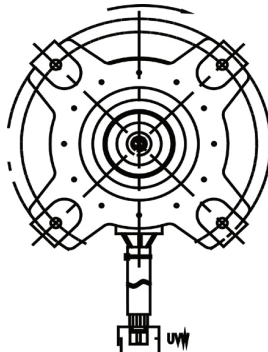

3. Indoor AC Fan Motor

Power on and set the unit running in fan mode at high fan speed. After running for 15 seconds, measure the voltage of pin1 and pin2. If the value of the voltage is less than 100V(208~240V power supply) or 50V(115V power supply), the PCB must has problems and need to be replaced.

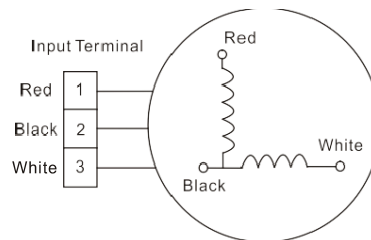

3.5. Error Codes: E4, E5, F1, F2 and F3

Description: Open circuit or short circuit of temperature sensor diagnosis and solution.

General Note: Error displays if voltage is lower than 0.06V or higher than 4.94V.

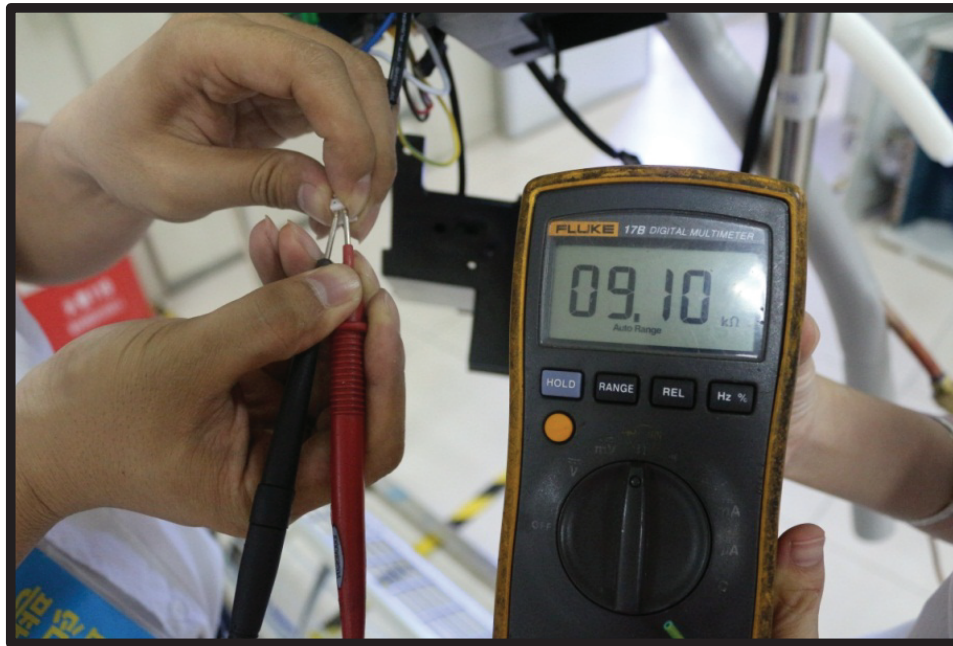
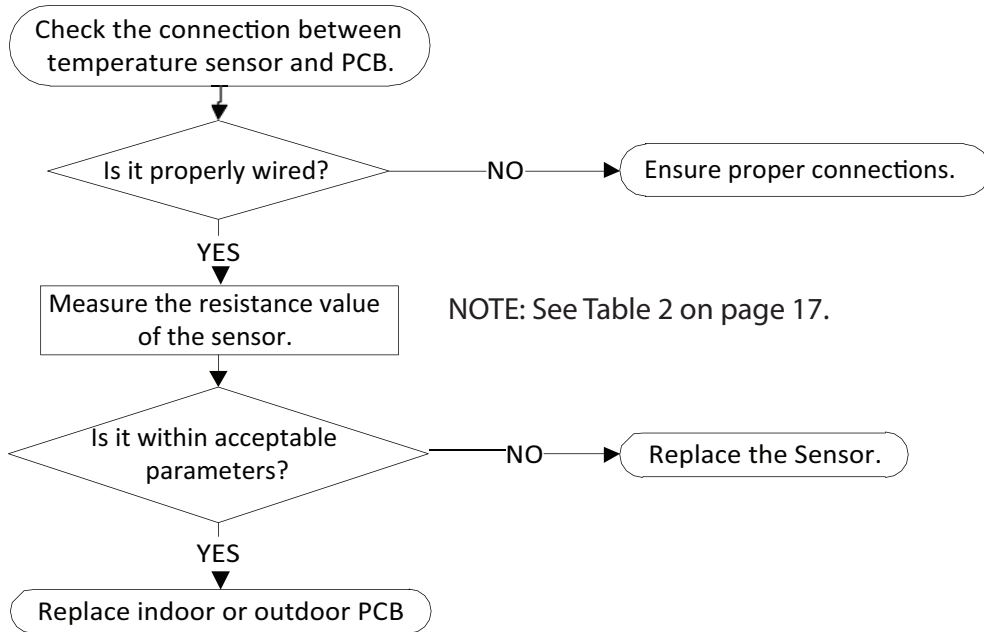

3.6. Error Code: EC

Description: Refrigerant Leakage Detection Diagnosis and Solution

General Note: Define the evaporator coil temperature T2 of the compressor just starts running as Tcool.
In the beginning eight minutes after the compressor starts up, if $T2 < T_{cool} - 2^{\circ}\text{C}$ does not keep continuous four seconds and compressor running frequency higher than 50Hz does not keep continuous three minutes, and this situation happens three times, the display area will show "EC" and AC will turn off.

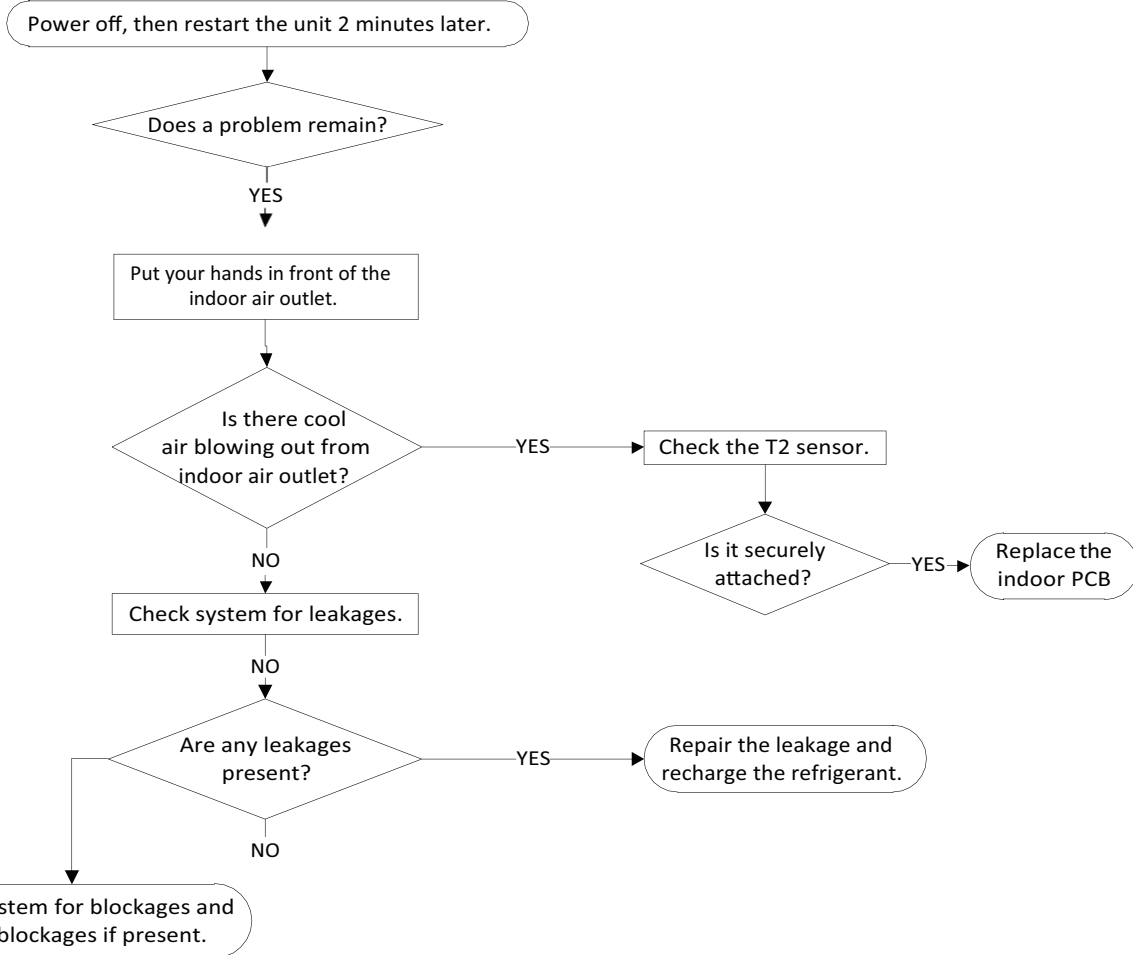

3.7. Error Codes: P0

Description: IPM malfunction or IGBT Over-Current Protection Diagnosis and Solution)

General Note: When the voltage signal the IPM sends to the compressor drive chip is abnormal, the display LED shows “P0” and the AC turn off.

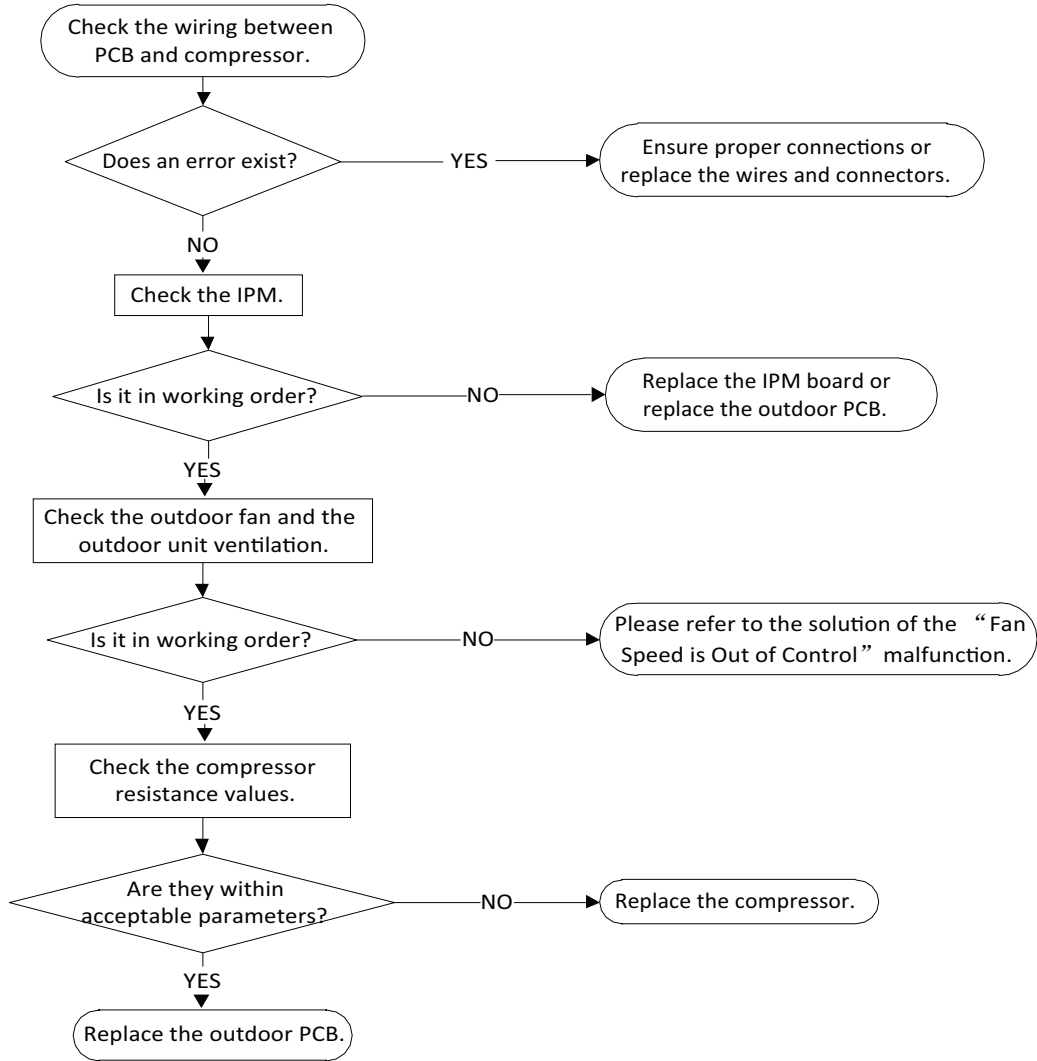

3.8. Error Code: P1

Description: Over voltage or too low voltage protection diagnosis and solution)

General Note: Abnormal increases or decreases in voltage are detected by checking the specified voltage detection circuit.

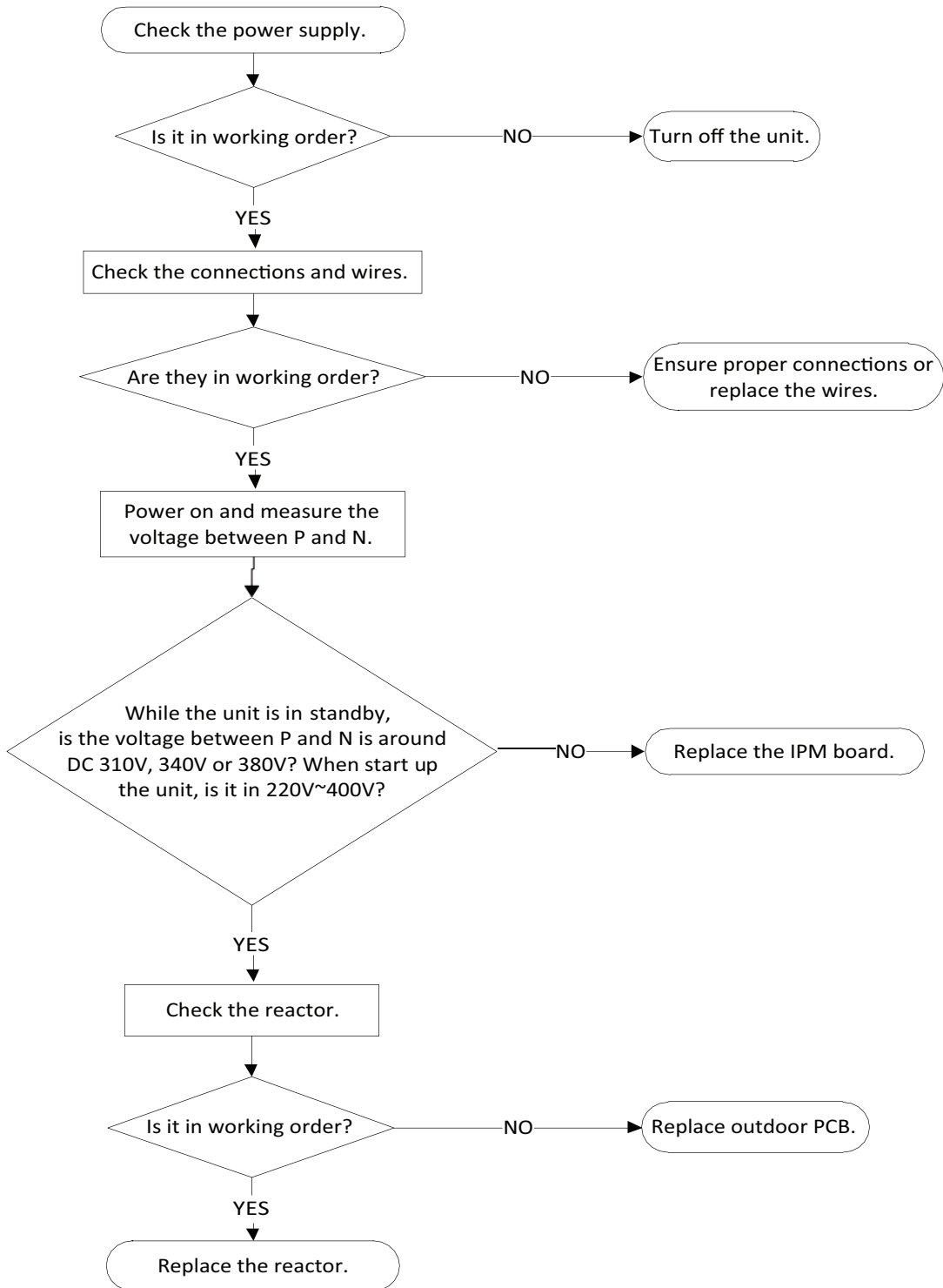

3.9. Error Code: P2

Description: High Temperature Protection of IPM module Diagnosis and Solution

General Note: If the temperature of IPM module is higher than setting value, the LED displays this failure code.

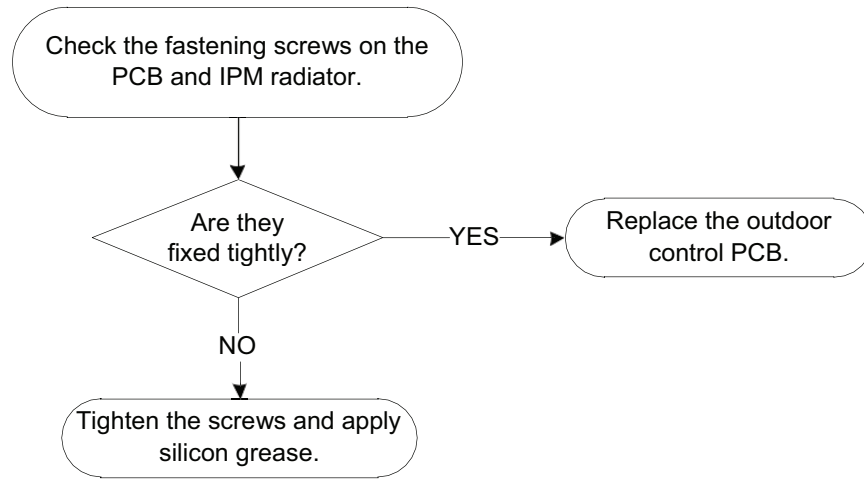

3.10. Error Code: P4

Description: Inverter Compressor Drive Error Diagnosis and Solution

General Note: An abnormal inverter compressor drive is detected by a special detection circuit, including communication signal detection, voltage detection, compressor rotation speed signal detection and so on.

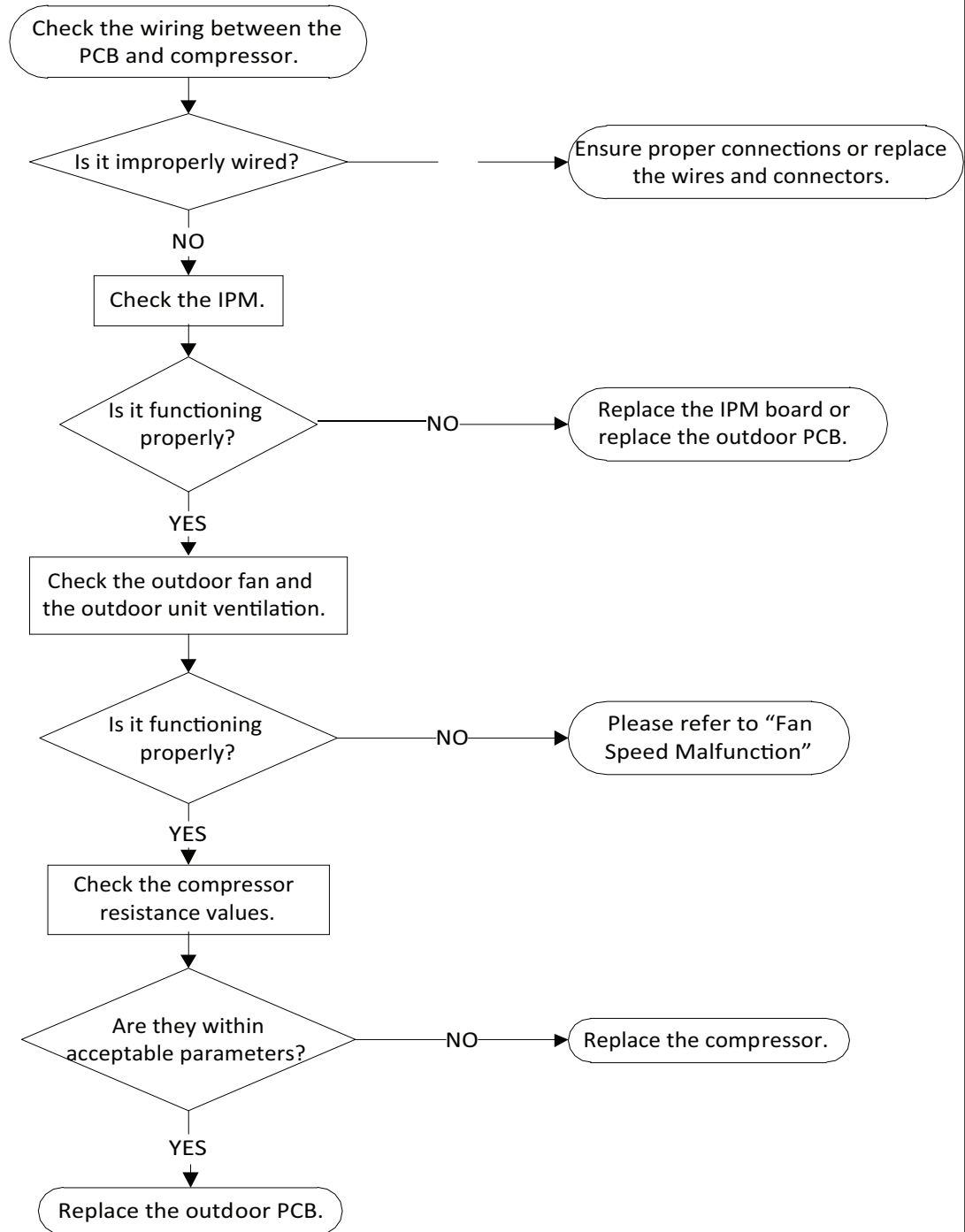

4. Temperature Sensor Resistance Values

Table 2. Temperature Sensor Resistance Value Table for T1,T2,T3 and T4 (°C – K)

°F	°C	K Ohm	°F	°C	K Ohm	°F	°C	K Ohm	°F	°C	K Ohm
-4	-20	115.266	68	20	12.6431	140	60	2.35774	212	100	0.62973
-2.2	-19	108.146	69.8	21	12.0561	141.8	61	2.27249	213.8	101	0.61148
-0.4	-18	101.517	71.6	22	11.5	143.6	62	2.19073	215.6	102	0.59386
1.4	-17	96.3423	73.4	23	10.9731	145.4	63	2.11241	217.4	103	0.57683
3.2	-16	89.5865	75.2	24	10.4736	147.2	64	2.03732	219.2	104	0.56038
5	-15	84.219	77	25	10	149	65	1.96532	221	105	0.54448
6.8	-14	79.311	78.8	26	9.55074	150.8	66	1.89627	222.8	106	0.52912
8.6	-13	74.536	80.6	27	9.12445	152.6	67	1.83003	224.6	107	0.51426
10.4	-12	70.1698	82.4	28	8.71983	154.4	68	1.76647	226.4	108	0.49989
12.2	-11	66.0898	84.2	29	8.33566	156.2	69	1.70547	228.2	109	0.486
14	-10	62.2756	86	30	7.97078	158	70	1.64691	230	110	0.47256
15.8	-9	58.7079	87.8	31	7.62411	159.8	71	1.59068	231.8	111	0.45957
17.6	-8	56.3694	89.6	32	7.29464	161.6	72	1.53668	233.6	112	0.44699
19.4	-7	52.2438	91.4	33	6.98142	163.4	73	1.48481	235.4	113	0.43482
21.2	-6	49.3161	93.2	34	6.68355	165.2	74	1.43498	237.2	114	0.42304
23	-5	46.5725	95	35	6.40021	167	75	1.38703	239	115	0.41164
24.8	-4	44	96.8	36	6.13059	168.8	76	1.34105	240.8	116	0.4006
26.6	-3	41.5878	98.6	37	5.87359	170.6	77	1.29078	242.6	117	0.38991
28.4	-2	39.8239	100.4	38	5.62961	172.4	78	1.25423	244.4	118	0.37956
30.2	-1	37.1988	102.2	39	5.39689	174.2	79	1.2133	246.2	119	0.36954
32	0	35.2024	104	40	5.17519	176	80	1.17393	248	120	0.35982
33.8	1	33.3269	105.8	41	4.96392	177.8	81	1.13604	249.8	121	0.35042
35.6	2	31.5635	107.6	42	4.76253	179.6	82	1.09958	251.6	122	0.3413
37.4	3	29.9058	109.4	43	4.5705	181.4	83	1.06448	253.4	123	0.33246
39.2	4	28.3459	111.2	44	4.38736	183.2	84	1.03069	255.2	124	0.3239
41	5	26.8778	113	45	4.21263	185	85	0.99815	257	125	0.31559
42.8	6	25.4954	114.8	46	4.04589	186.8	86	0.96681	258.8	126	0.30754
44.6	7	24.1932	116.6	47	3.88673	188.6	87	0.93662	260.6	127	0.29974
46.4	8	22.5662	118.4	48	3.73476	190.4	88	0.90753	262.4	128	0.29216
48.2	9	21.8094	120.2	49	3.58962	192.2	89	0.8795	264.2	129	0.28482
50	10	20.7184	122	50	3.45097	194	90	0.85248	266	130	0.2777
51.8	11	19.6891	123.8	51	3.31847	195.8	91	0.82643	267.8	131	0.27078
53.6	12	18.7177	125.6	52	3.19183	197.6	92	0.80132	269.6	132	0.26408
55.4	13	17.8005	127.4	53	3.07075	199.4	93	0.77709	271.4	133	0.25757
57.2	14	16.9341	129.2	54	2.95896	201.2	94	0.75373	273.2	134	0.25125
59	15	16.1156	131	55	2.84421	203	95	0.73119	275	135	0.24512
60.8	16	15.3418	132.8	56	2.73823	204.8	96	0.70944	276.8	136	0.23916
62.6	17	14.6181	134.6	57	2.63682	206.6	97	0.68844	278.6	137	0.23338
64.4	18	13.918	136.4	58	2.53973	208.4	98	0.66818	280.4	138	0.22776
66.2	19	13.2631	138.2	59	2.44677	210.2	99	0.64862	282.2	139	0.22231

5. Discharge Temperature Sensor Resistance Values

Table 3. Temperature Sensor Resistance Value Table for TP (°C – K)

°F	°C	K Ohm	°F	°C	K Ohm	°F	°C	K Ohm	°F	°C	K Ohm
-4	-20	542.7	68	20	68.66	140	60	13.59	212	100	3.702
-2.2	-19	511.9	69.8	21	65.62	141.8	61	13.11	213.8	101	3.595
-0.4	-18	455.9	71.6	22	59.98	143.6	62	12.21	215.6	102	3.392
1.4	-17	455.9	73.4	23	59.98	145.4	63	12.21	217.4	103	3.392
3.2	-16	430.5	75.2	24	57.37	147.2	64	11.79	219.2	104	3.296
5	-15	406.7	77	25	54.89	149	65	11.38	221	105	3.203
6.8	-14	384.3	78.8	26	52.53	150.8	66	10.99	222.8	106	3.113
8.6	-13	363.3	80.6	27	50.28	152.6	67	10.61	224.6	107	3.025
10.4	-12	343.6	82.4	28	48.14	154.4	68	10.25	226.4	108	2.941
12.2	-11	325.1	84.2	29	46.11	156.2	69	9.902	228.2	109	2.86
14	-10	307.7	86	30	44.17	158	70	9.569	230	110	2.781
15.8	-9	291.3	87.8	31	42.33	159.8	71	9.248	231.8	111	2.704
17.6	-8	275.9	89.6	32	40.57	161.6	72	8.94	233.6	112	2.63
19.4	-7	261.4	91.4	33	38.89	163.4	73	8.643	235.4	113	2.559
21.2	-6	247.8	93.2	34	37.3	165.2	74	8.358	237.2	114	2.489
23	-5	234.9	95	35	35.78	167	75	8.084	239	115	2.422
24.8	-4	222.8	96.8	36	34.32	168.8	76	7.82	240.8	116	2.357
26.6	-3	211.4	98.6	37	32.94	170.6	77	7.566	242.6	117	2.294
28.4	-2	200.7	100.4	38	31.62	172.4	78	7.321	244.4	118	2.233
30.2	-1	190.5	102.2	39	30.36	174.2	79	7.086	246.2	119	2.174
32	0	180.9	104	40	29.15	176	80	6.859	248	120	2.117
33.8	1	171.9	105.8	41	28	177.8	81	6.641	249.8	121	2.061
35.6	2	163.3	107.6	42	26.9	179.6	82	6.43	251.6	122	2.007
37.4	3	155.2	109.4	43	25.86	181.4	83	6.228	253.4	123	1.955
39.2	4	147.6	111.2	44	24.85	183.2	84	6.033	255.2	124	1.905
41	5	140.4	113	45	23.89	185	85	5.844	257	125	1.856
42.8	6	133.5	114.8	46	22.89	186.8	86	5.663	258.8	126	1.808
44.6	7	127.1	116.6	47	22.1	188.6	87	5.488	260.6	127	1.762
46.4	8	121	118.4	48	21.26	190.4	88	5.32	262.4	128	1.717
48.2	9	115.2	120.2	49	20.46	192.2	89	5.157	264.2	129	1.674
50	10	109.8	122	50	19.69	194	90	5	266	130	1.632
51.8	11	104.6	123.8	51	18.96	195.8	91	4.849			
53.6	12	99.69	125.6	52	18.26	197.6	92	4.703			
55.4	13	95.05	127.4	53	17.58	199.4	93	4.562			
57.2	14	90.66	129.2	54	16.94	201.2	94	4.426			
59	15	86.49	131	55	16.32	203	95	4.294			B(25/50)=3950K
60.8	16	82.54	132.8	56	15.73	204.8	96	4.167			
62.6	17	78.79	134.6	57	15.16	206.6	97	4.045			R(90°C)=5KΩ±3%
64.4	18	75.24	136.4	58	14.62	208.4	98	3.927			
66.2	19	71.86	138.2	59		210.2	99	3.812			

6. Pressure on Service Port (R-410A)

°F(°C)	IDT/ODT	0 (-17)	5 (-15)	15 (9.44)	45 (7.22)	75 (23.89)	85 (29.44)	95 (35)	105 (40.56)	115 (46.11)	120 (48.89)
BAR	70/59	6.4	6.5	7.3	8	8.2	7.8	8.1	8.6	10.1	10.6
BAR	75/63	6.7	6.8	7.9	8.6	8.6	8.3	8.7	9.1	10.7	11.2
BAR	80/67	7.1	7.2	8.5	9.5	9.3	8.9	9.1	9.6	11.2	11.9
BAR	90/73	7.7	7.8	9.6	10.5	10.3	9.5	10	10.6	12.4	13

°F(°C)	IDT/ODT	0 (-17)	5 (-15)	15 (9.44)	45 (7.22)	75 (23.89)	85 (29.44)	95 (35)	105 (40.56)	115 (46.11)	120 (48.89)
PSI	70/59	93	94	106	116	119	113	117	125	147	154
PSI	75/63	97	99	115	125	124	120	126	132	155	162
PSI	80/67	103	104	123	138	135	129	132	140	162	173
PSI	90/73	112	113	139	152	149	138	145	154	180	189

°F(°C)	IDT/ODT	0 (-17)	5 (-15)	15 (9.44)	45 (7.22)	75 (23.89)	85 (29.44)	95 (35)	105 (40.56)	115 (46.11)	120 (48.89)
MPA	70/59	0.64	0.65	0.73	0.8	0.82	0.78	0.81	0.86	1.01	1.06
MPA	75/63	0.67	0.68	0.79	0.86	0.86	0.83	0.87	0.91	1.07	1.12
MPA	80/67	0.71	0.72	0.85	0.95	0.93	0.89	0.91	0.96	1.12	1.19
MPA	90/73	0.77	0.78	0.96	1.05	1.03	0.95	1	1.06	1.24	1.3

