

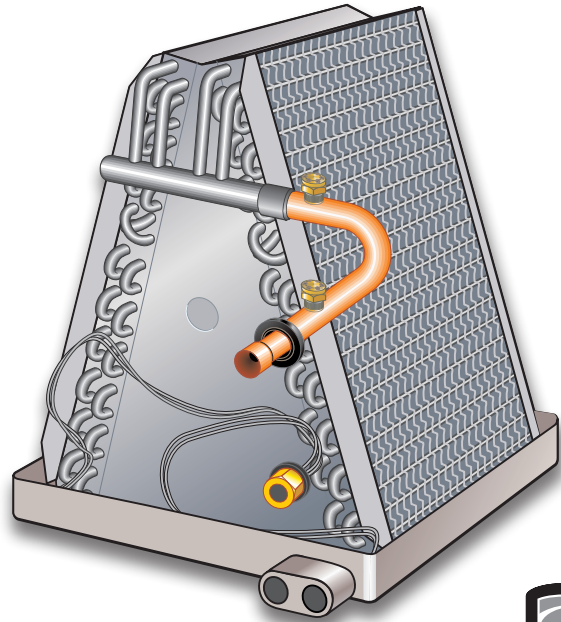

Upflow - Cased and Uncased

**RESIDENTIAL
PRODUCT SPECIFICATIONS**

Bulletin No. 210666
June 2021
Supersedes May 2019

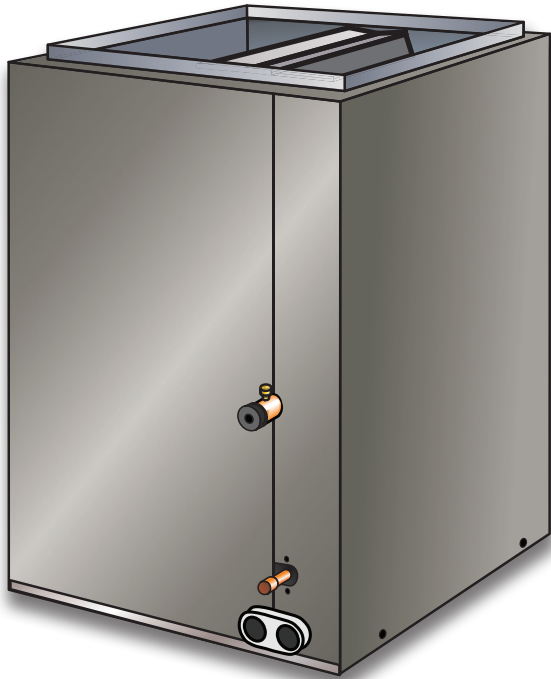

1.5 to 5 Tons

MODEL NUMBER IDENTIFICATION

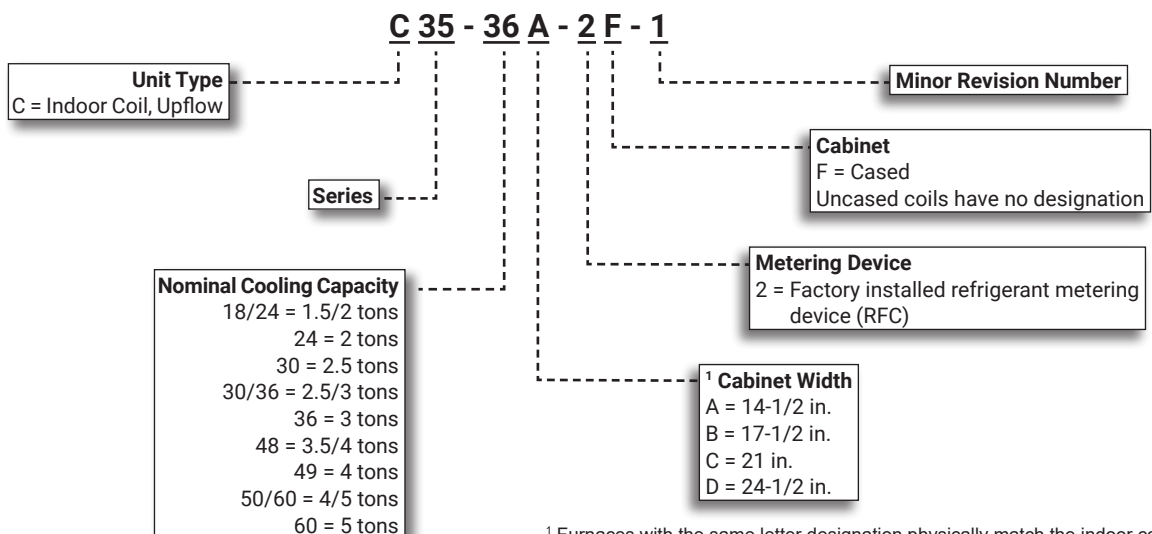

¹ Furnaces with the same letter designation physically match the indoor coil. Uncased coils have different widths, but will fit the corresponding furnace cabinet.

CONTENTS

Air Resistance	6
Approvals and Warranty	2
C33 to C35 Cased Coil Cross-Reference	16
C33 to C35 Uncased Coil Cross-Reference	15
Dimensions	8
Dimensions - Furnace/Coil Combined Dimensions	14
Features	2
Model Number Identification.	1
Optional Accessories - Order Separately	5
Specifications	4

APPROVALS AND WARRANTY

APPROVALS

- Tested with matching air conditioners and heat pump units in the Lennox Research Laboratory environmental test room in accordance with AHRI Standard 210/240
- AHRI Certified system match-ups and expanded ratings, visit www.LennoxPros.com
- Air resistance tests from Lennox Laboratory air test chamber

WARRANTY

- All other covered components:
 - Limited five years in residential installations
 - Limited one year in non-residential installations

NOTE - Refer to Lennox Equipment Limited Warranty certificate included with unit for specific details.

FEATURES

APPLICATIONS

- 1.5 to 5 ton nominal sizes
- Lennox designed upflow indoor coils can easily be installed with most Lennox upflow furnaces
- Applicable to expansion valve or RFCIV systems
- RFCIV metering device is factory installed

NOTE - RFCIV systems are applicable to certain air conditioners only.

NOTE - Expansion valve systems require field installed kit

COIL CONSTRUCTION

Quantum™ Coil

- Lennox designed and fabricated coil
- Aluminum tubing, hairpins, distributor and header tubes
- Copper refrigerant sweat connections on both liquid and suction lines for easy brazing
- Ripple-edged aluminum fins
- Lanced fins provide maximum exposure of fin surface to air stream
- Rifled tubing provides superior refrigerant heat transfer
- Twin coil construction assembled in an "A" configuration for large surface area

- Liquid line seal nut section furnished for installation of expansion valve
- High pressure testing insures leak-proof construction

Anti-Microbial Drain Pan

- Non-corrosive, UV-resistant polymer drain pan with dual fpt drain connections
- Anti-Microbial additive resists growth of mold and mildew on drain pan which improves indoor air quality and reduces drain line blockage

Universal Piping Patch Plate (Uncased Coils Only)

- Shipped with the coil for field installation over the liquid and suction lines
- Plate has a scored line so it can be separated for different coils where the liquid and suction lines are farther apart

FEATURES

REFRIGERANT CONTROL CHOICE

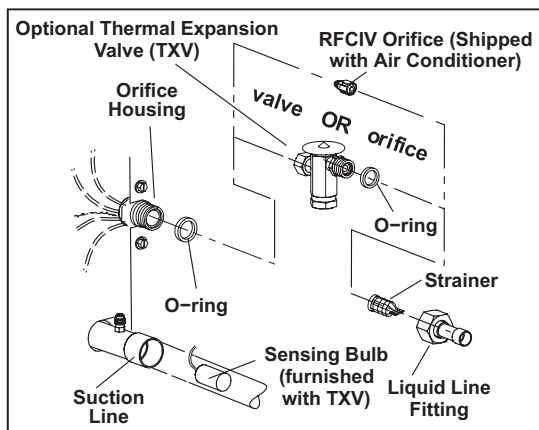

- All models applicable to Lennox RFCIV refrigerant metering system when matched with specific air conditioners
- See Air Conditioners Product Specifications for applications

NOTE - In certain applications the RFC orifice furnished with the coil must be replaced with the orifice furnished with the air conditioner. Refer to the air conditioner Product Specifications to determine if replacement is required.

NOTE - Optional expansion valve is required in most applications and must be ordered separately.

Refrigerant Flow Control IV

- RFCIV accurately meters refrigerant in system
- Refrigerant control is accomplished by exact sizing of refrigerant metering orifice
- Principle of Lennox RFCIV system involves matching evaporator coil with proper bore size of orifice in metering device
- RFCIV system equalizes pressure shortly after compressor stops, unit starts unloaded, eliminating need for additional controls

Optional Accessories

Expansion Valve Kits

- Expansion valve available for field installation
- See Air Conditioners or Heat Pump Outdoor Units Product Specifications for expansion valve kit selection

CABINET

Construction - Cased (F) Coils

- Insulated with thick fiberglass insulation
- Constructed of pre-painted heavy gauge steel
- Flanges provided in outlet opening for ease of plenum connection
- Engaging holes furnished for alignment with furnace
- Removable panels provide access to coil
- See dimension drawing

Furnace Match-Up

- Coils exactly match corresponding furnaces with same letter designation in model number
- No adaptor required
- Engaging holes furnished for alignment
- Uncased coils match furnaces without any overhang but require optional adaptor base or field fabricated transition to match furnace opening

Optional Accessories

Adjustable Coil Adaptor/Seal

- For uncased coils
- Telescoping adaptor provides quick and easy installation
- See dimension drawings and application drawings
- Available ten pack kits

SPECIFICATIONS		1.5 TO 2 TON			
General Data	Uncased Model No.	C35-18/24A-2	C35-18/24B-2	C35-24A-2	C35-24B-2
	Cased Model No.	C35-18/24A-2F	C35-18/24B-2F	C35-24A-2F	C35-24B-2F
	Nominal size - Tons	1.5 / 2	1.5 / 2	2	2
Line Connections in.	Suction / vapor o.d. - sweat	3/4	3/4	3/4	3/4
	Liquid o.d. - sweat	3/8	3/8	3/8	3/8
	Condensate drain (fpt)	(2) 3/4	(2) 3/4	(2) 3/4	(2) 3/4
RFCIV metering device orifice size		0.053	0.053	0.057	0.057
Indoor Coil	Net face area sq. ft.	3.11	3.11	3.55	3.55
	Tube diameter - in.	3/8	3/8	3/8	3/8
	Number of rows	2	2	3	3
	Fins per inch	18	18	14	14
Matching Lennox Furnace - Cabinet Width Designation		A	B	A	B
¹ Coil & Furnace Cabinet Width - in.		14-1/2	17-1/2	14-1/2	17-1/2
Shipping Data - lbs.	Uncased	18	20	23	24
	Cased	30	34	38	43

¹ Uncased coils match furnaces without any overhang but require optional adaptor base or field fabricated transition to match furnace width.

SPECIFICATIONS		2.5 TO 3 TON			
General Data	Uncased Model No.	C35-30A-2	C35-30B-2	C35-30/36A-2	C35-30/36B-2
	Cased Model No.	C35-30A-2F	C35-30B-2F	C35-30/36A-2F	C35-30/36B-2F
	Nominal size - Tons	2.5	2.5	2.5 / 3	2.5 / 3
Line Connections in.	Suction / vapor o.d. - sweat	3/4	3/4	3/4	3/4
	Liquid o.d. - sweat	3/8	3/8	3/8	3/8
	Condensate drain (fpt)	(2) 3/4	(2) 3/4	(2) 3/4	(2) 3/4
RFCIV metering device orifice size		0.067	0.067	0.057	0.057
Indoor Coil	Net face area sq. ft.	4.44	4.44	4.89	5.77
	Tube diameter - in.	3/8	3/8	3/8	3/8
	Number of rows	3	3	2	2
	Fins per inch	13	13	18	18
Matching Lennox Furnace - Cabinet Width Designation		A	B	A	B
¹ Coil & Furnace Cabinet Width - in.		14-1/2	17-1/2	14-1/2	17-1/2
Shipping Data - lbs.	Uncased	31	32	26	27
	Cased	45	50	41	45

¹ Uncased coils match furnaces without any overhang but require optional adaptor base or field fabricated transition to match furnace width.

SPECIFICATIONS **2.5 TO 4 TON**

General Data		Uncased Model No.	C35-30/36C-2	C35-36A-2	C35-36B-2	C35-48B-2	C35-48C-2
		Cased Model No.	C35-30/36C-2F	C35-36A-2F	C35-36B-2F	C35-48B-2F	C35-48C-2F
		Nominal size - Tons	2.5 / 3	3	3	3.5 / 4	3.5 / 4
Line Connections in.	Suction / vapor o.d. - sweat		3/4	3/4	3/4	7/8	7/8
	Liquid o.d. - sweat		3/8	3/8	3/8	3/8	3/8
	Condensate drain (fpt)		(2) 3/4	(2) 3/4	(2) 3/4	(2) 3/4	(2) 3/4
RFCIV metering device orifice size			0.057	0.070	0.070	0.071	0.071
Indoor Coil	Net face area sq. ft.		5.77	4.89	4.89	5.77	5.77
	Tube diameter - in.		3/8	3/8	3/8	3/8	3/8
	Number of rows		2	3	3	3	3
	Fins per inch		18	14	14	13	13
Matching Lennox Furnace - Cabinet Width Designation			C	A	B	B	C
¹ Coil & Furnace Cabinet Width - in.			21	14-1/2	17-1/2	17-1/2	21
Shipping Data - lbs.	Uncased		29	31	33	43	44
	Cased		48	46	50	55	60

¹ Uncased coils match furnaces without any overhang but require optional adaptor base or field fabricated transition to match furnace width.

SPECIFICATIONS **4 TO 5 TON**

General Data		Uncased Model No.	C35-49C-2	C35-50/60C-2	C35-60C-2	C35-60D-2
		Cased Model No.	C35-49C-2F	C35-50/60C-2F	C35-60C-2F	C35-60D-2F
		Nominal size - Tons	4	4 / 5	5	5
Line Connections in.	Suction / vapor o.d. - sweat		7/8	7/8	7/8	7/8
	Liquid o.d. - sweat		3/8	3/8	3/8	3/8
	Condensate drain (fpt)		(2) 3/4	(2) 3/4	(2) 3/4	(2) 3/4
RFCIV metering device orifice size			0.076	0.070	0.077	0.077
Indoor Coil	Net face area sq. ft.		7.0	5.78	7.50	7.58
	Tube diameter - in.		3/8	3/8	3/8	3/8
	Number of rows		3	3	3	3
	Fins per inch		15	12	16	14
Matching Lennox Furnace - Cabinet Width Designation			C	C	C	D
Coil & Furnace Cabinet Width - in.			21	21	21	24-1/2
Shipping Data - lbs.	Uncased		53	40	58	48
	Cased		70	60	73	72

¹ Uncased coils match furnaces without any overhang but require optional adaptor base or field fabricated transition to match furnace width.

OPTIONAL ACCESSORIES - ORDER SEPARATELY

Adjustable Coil Adaptor/Seal - Uncased models only (Ten Pack)	11L09
--	--------------

AIR RESISTANCE

Model No.	Air Volume cfm	Total Resistance	
		Dry Coil	Wet Coil
		in. w.g.	in. w.g.
C35-18/24A-2 C35-18/24B-2	400	0.06	0.08
	600	0.11	0.17
	800	0.18	0.25
	1000	0.27	0.39
	1200	0.37	0.52
C35-24A-2	400	0.05	0.05
	600	0.09	0.10
	800	0.16	0.18
	1000	0.23	0.26
	1200	0.32	0.36
C35-24B-2	400	0.03	0.04
	600	0.07	0.09
	800	0.11	0.15
	1000	0.17	0.22
	1200	0.23	0.31
C35-30A-2	600	0.07	0.08
	800	0.12	0.13
	1000	0.18	0.20
	1200	0.26	0.28
	1400	0.34	0.37
C35-30B-2	600	0.06	0.06
	800	0.09	0.11
	1000	0.13	0.16
	1200	0.19	0.23
	1400	0.25	0.31
C35-30/36A-2	800	0.13	0.14
	1000	0.19	0.21
	1200	0.27	0.30
	1400	0.34	0.39
	1600	0.45	0.51
C35-30/36B-2 C35-30/36C-2 C35-36B-2	800	0.08	0.11
	1000	0.13	0.16
	1200	0.17	0.21
	1400	0.22	0.28
	1600	0.29	0.34

Model No.	Air Volume cfm	Total Resistance	
		Dry Coil	Wet Coil
		in. w.g.	in. w.g.
C35-36A-2	800	0.13	0.14
	1000	0.19	0.21
	1200	0.27	0.30
	1400	0.34	0.39
	1600	0.45	0.51
	1800	0.57	0.65
C35-48B-2	1000	0.13	0.13
	1200	0.18	0.18
	1400	0.23	0.24
	1600	0.30	0.31
	1800	0.37	0.40
C35-48C-2	1000	0.07	0.09
	1200	0.10	0.12
	1400	0.13	0.16
	1600	0.16	0.20
	1800	0.20	0.24
C35-49C-2	1200	0.08	0.12
	1400	0.13	0.17
	1600	0.17	0.22
	1800	0.22	0.28
	2000	0.28	0.35
C35-50/60C-2	1200	0.13	0.17
	1400	0.18	0.23
	1600	0.23	0.29
	1800	0.28	0.37
	2000	0.34	0.43
C35-60D-2	1400	0.11	0.15
	1600	0.14	0.18
	1800	0.17	0.21
	2000	0.21	0.27
	2200	0.25	0.32
	2400	0.30	0.37
C35-60C-2	1400	0.15	0.19
	1600	0.19	0.23
	1800	0.24	0.28
	2000	0.29	0.34
	2200	0.33	0.40
	2400	0.39	0.46

OPTIONAL ACCESSORIES - ADJUSTABLE UNCASSED COIL ADAPTOR/SEAL

C35-18/24A thru C35-60C UNCASSED COILS

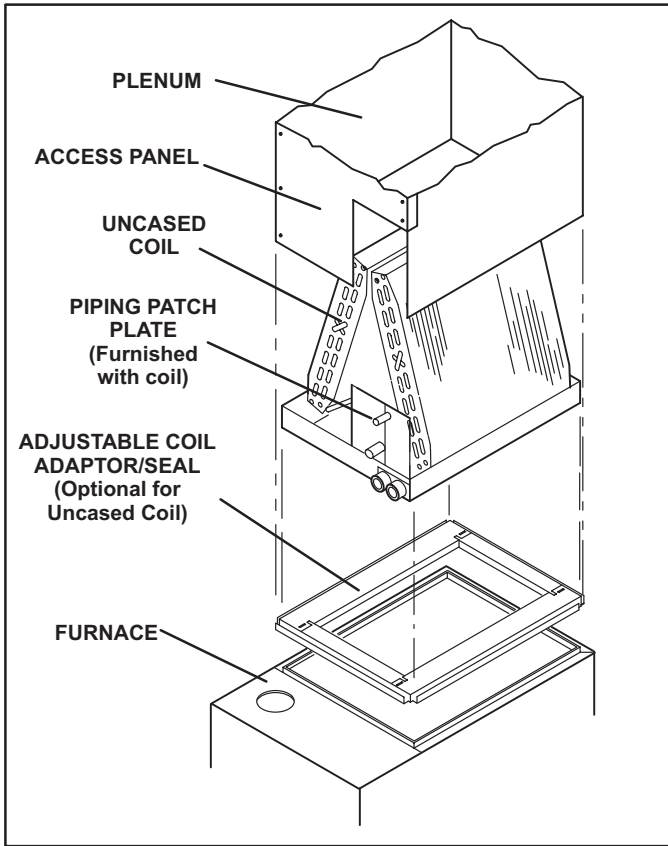

C35-60D UNCASSED COILS

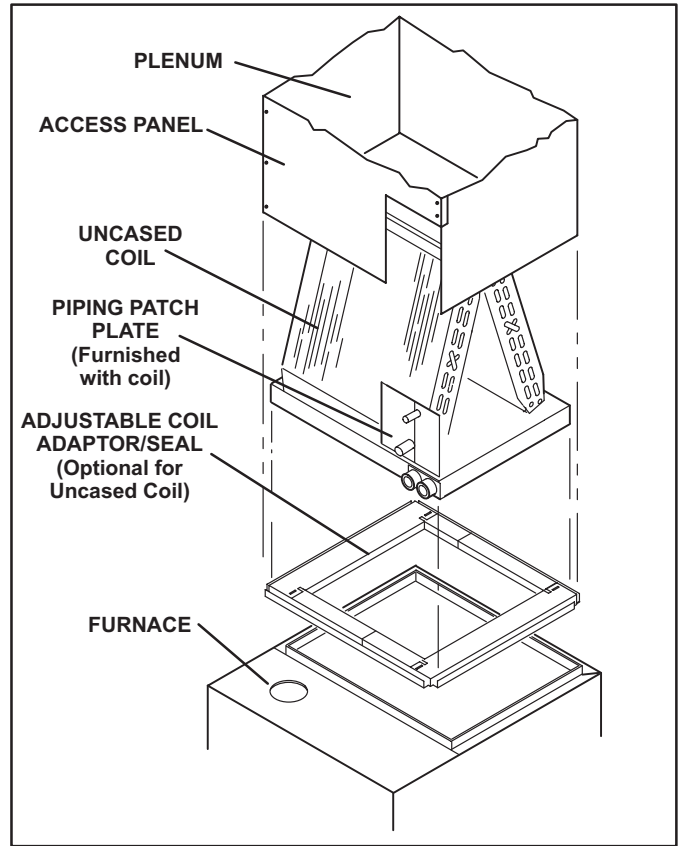

ADJUSTABLE COIL ADAPTOR/SEAL DIMENSIONS — inches (mm)

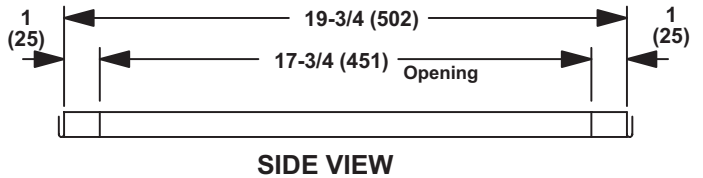
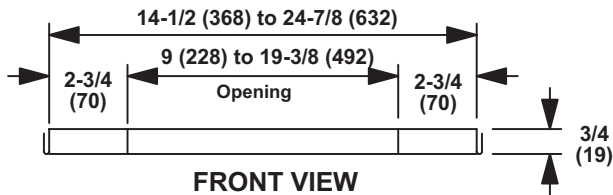

ADJUSTABLE COIL ADAPTOR/SEAL DETAIL

Frame Telescopes To Accommodate Various Furnace Openings

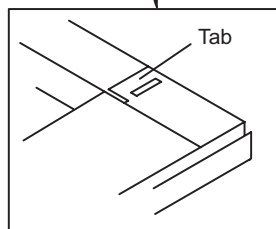
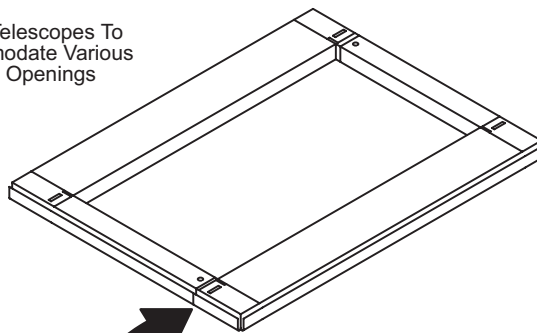

Tab may be bent up 90° for centering of smaller coils.

C35-18/24A, -18/24B, -24A, -24B Coils

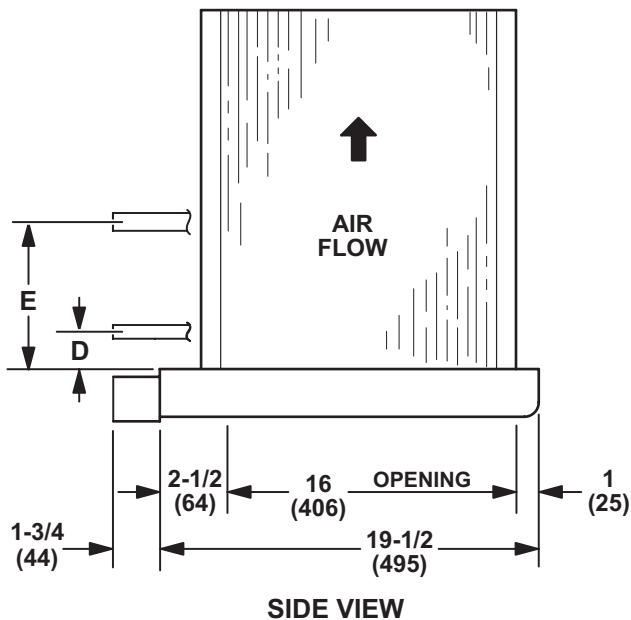
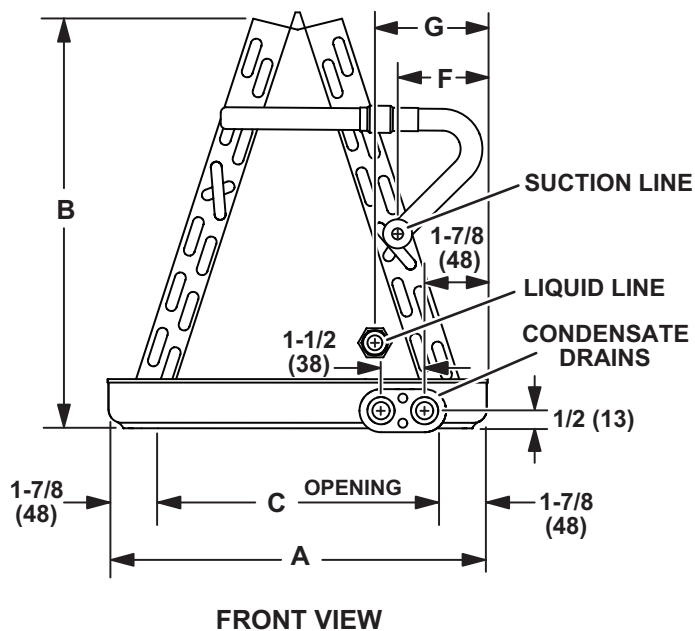

Model Number	A		B		C		D		E		F		G	
	in.	mm	in.	mm	in.	mm	in.	mm	in.	mm	in.	mm	in.	mm
C35-18/24A	13	330	14-1/8	359	9-1/4	235	1-1/4	32	5	127	3-1/8	79	3-7/8	98
C35-18/24B	15-1/2	394	14-1/8	359	11-3/4	298	1	25	4-5/8	117	2-7/8	73	3-5/8	92
C35-24A	13	330	16-3/8	416	9-1/4	235	2-7/8	73	7-5/8	194	3-1/8	79	3-3/4	95
C35-24B	15-1/2	394	16-3/8	416	11-3/4	298	2-1/4	57	7-1/2	190	3-1/8	79	4	102

C35-30A Coil

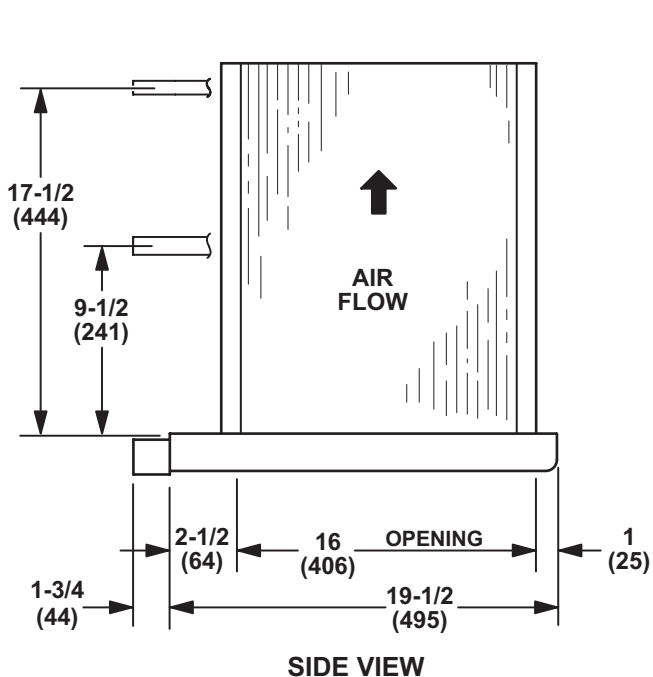
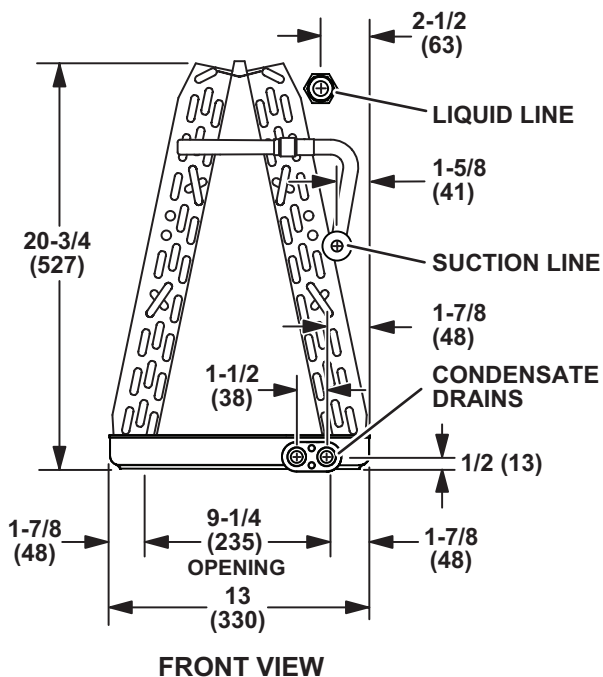

C35-30B, -30/36A, -30/36B, -30/36C, -36A, -36B, -48B, -48C, -50/60C Coils

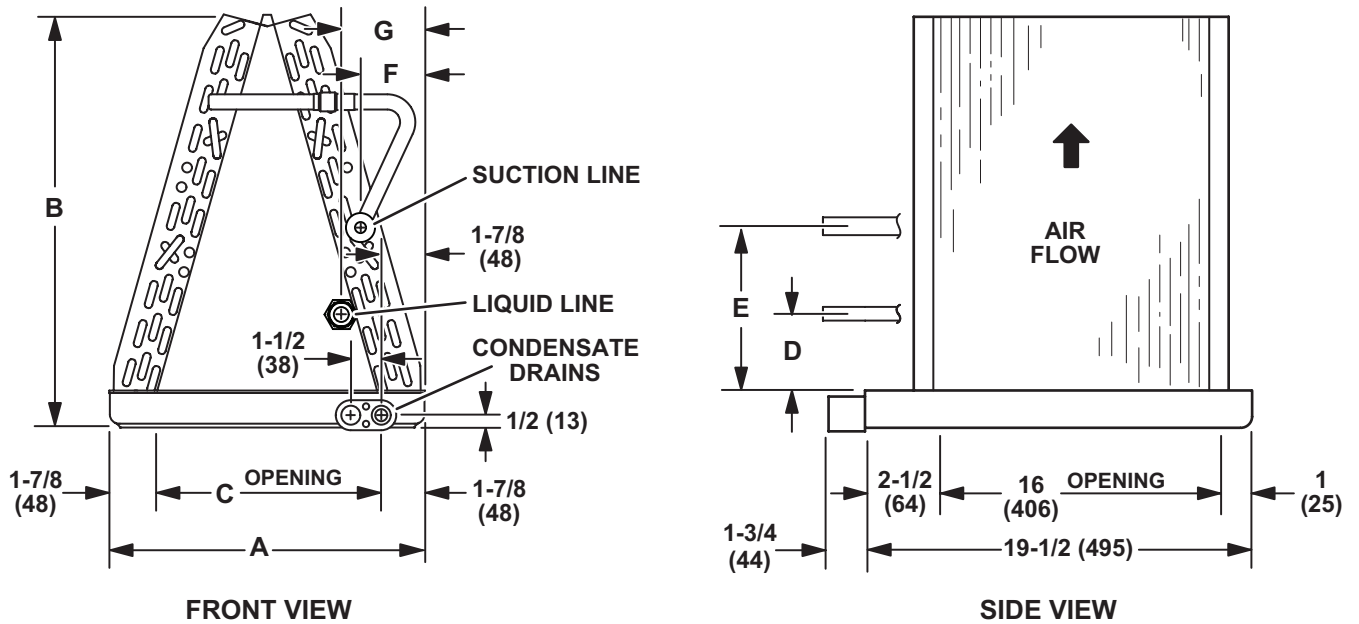

Model Number	A		B		C		D		E		F		G	
	in.	mm	in.	mm	in.	mm	in.	mm	in.	mm	in.	mm	in.	mm
C35-30B	15-1/2	394	20-3/4	527	11-3/4	298	3-1/8	79	8	203	3-1/8	79	4	102
C35-30/36A	13	330	22-1/4	565	9-1/4	235	2-1/2	64	11-3/4	298	3-1/8	79	3-7/8	98
C35-30/36B	15-1/2	394	22-1/4	565	11-3/4	298	2-5/8	67	11	279	3-1/8	79	4	102
C35-30/36C	20	508	22-1/4	565	16-1/4	413	2-3/8	60	11-7/8	302	3-1/8	79	4	102
C35-36A	13	330	22-3/8	568	9-1/4	235	4-1/4	108	12-5/8	321	2-1/2	64	3-1/2	89
C35-36B	15-1/2	394	22-3/8	568	11-3/4	298	4-1/2	114	13	330	2-7/8	73	3-5/8	92
C35-48B	15-1/2	394	26-1/4	667	11-3/4	298	4-3/8	111	12-1/4	311	3-1/8	79	3-3/4	95
C35-48C	20	508	26-1/4	667	16-1/4	413	4-1/8	105	11-3/4	298	3-1/8	79	3-3/4	95
C35-50/60C	20	508	25-7/8	657	16-1/4	413	3-3/4	95	11-3/4	298	3-1/8	79	4	102

C35-49C Coil

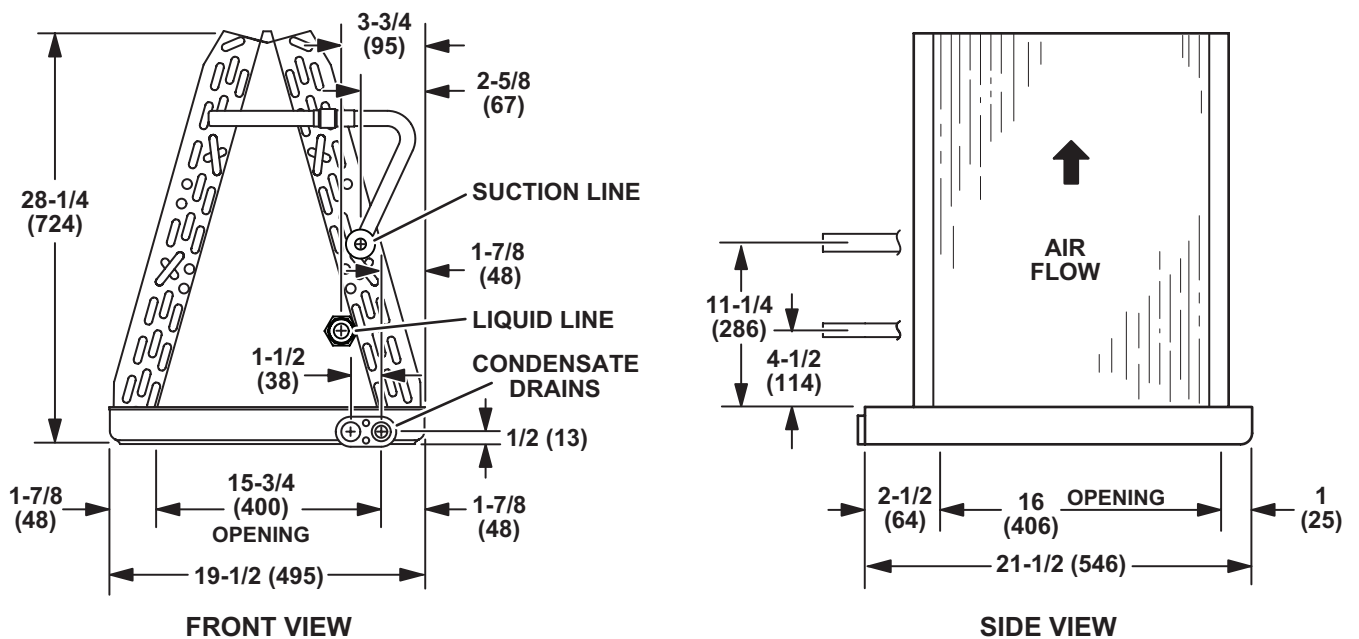

C35-60C Coil

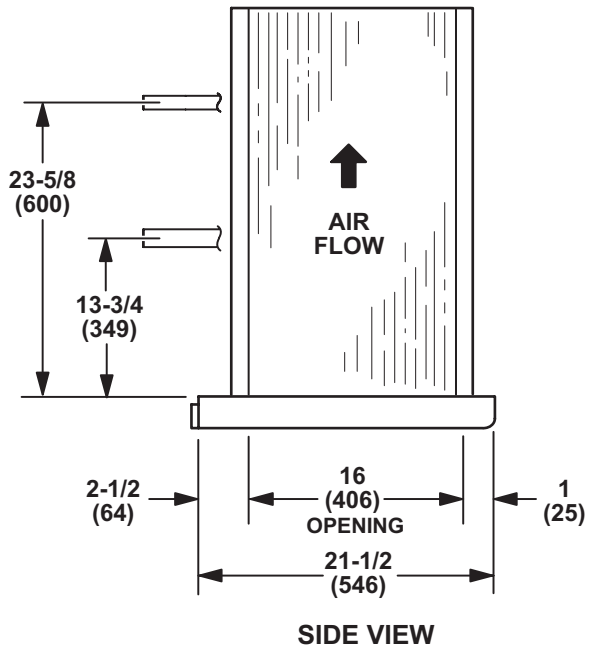
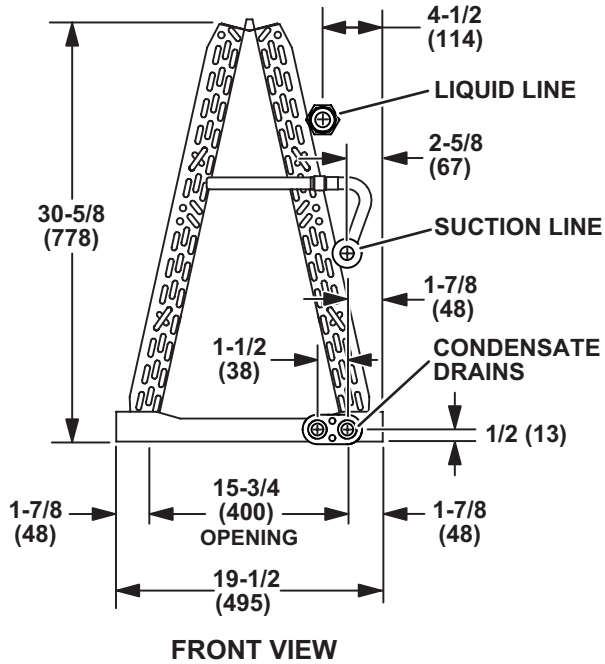

C35-60D Coil

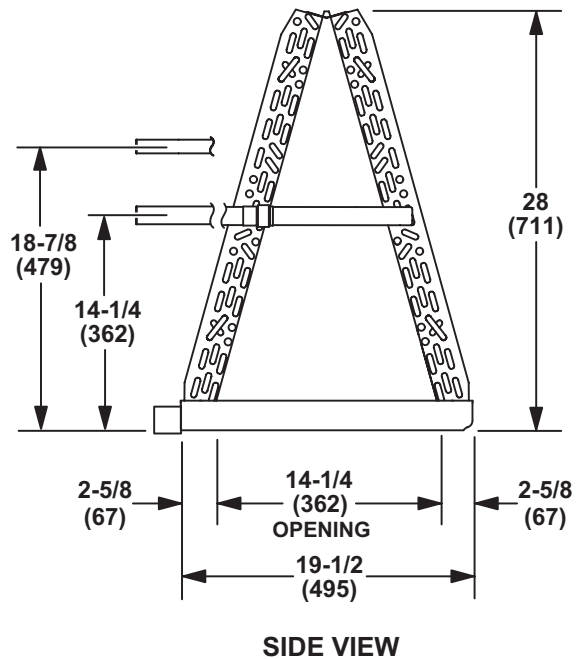
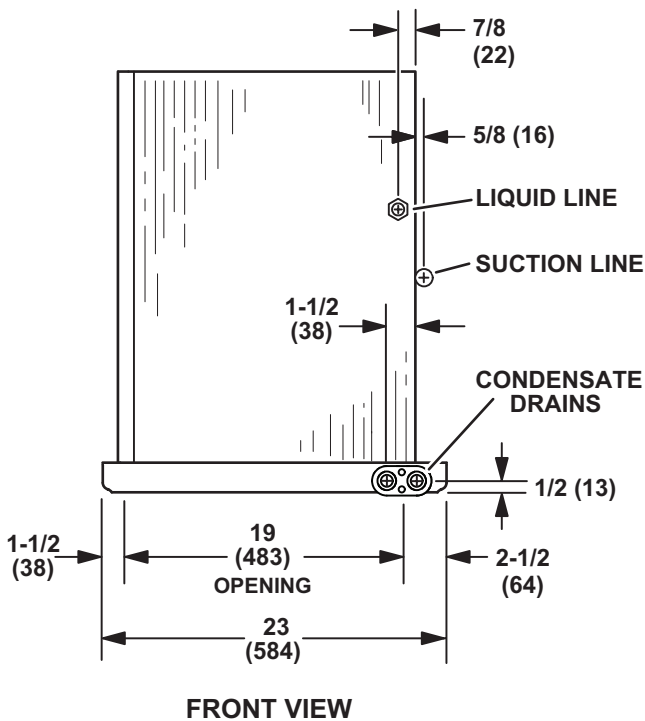

C35-18/24(A/B), -30/36(A/B/C), -36(A/B) Coils

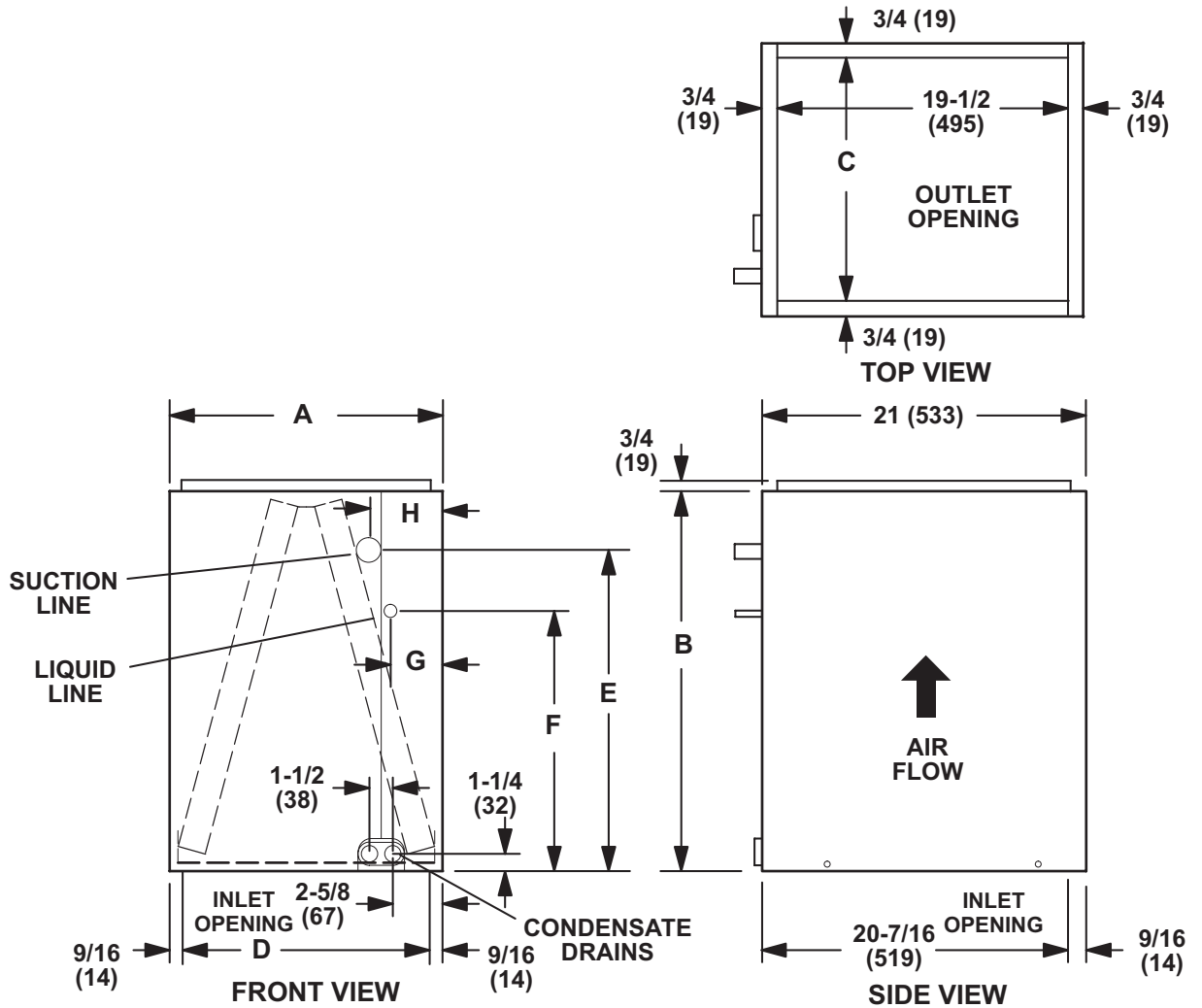

Model Number	A		B		C		D		E		F		G		H	
	in.	mm	in.	mm	in.	mm	in.	mm	in.	mm	in.	mm	in.	mm	in.	mm
C35-18/24A-2F	14-1/2	368	16-1/2	419	13	330	13-3/8	340	7-3/8	187	3-1/2	89	3	76	3-7/8	98
C35-18/24B-2F	17-1/2	445	16-1/2	419	16	406	16-3/8	416	7	178	3-1/2	89	3	76	3-7/8	98
C35-30/36A-2F	14-1/2	368	24-1/2	622	13	330	13-3/8	340	14-1/4	362	4-3/4	121	3	76	3-7/8	98
C35-30/36B-2F	17-1/2	445	24-1/2	622	16	406	16-3/8	416	13-3/8	340	4-3/4	121	3	76	4-1/8	108
C35-30/36C-2F	21	533	24-1/2	622	19-1/2	495	19-7/8	505	14-3/8	365	4-3/4	121	3	76	3-5/8	92
C35-36A-2F	14-1/2	368	24-1/2	622	13	330	13-3/8	340	13-1/2	343	4-3/4	121	2	52	3-1/4	83
C35-36B-2F	17-1/2	445	24-1/2	622	16	406	16-3/8	416	13-3/4	350	4-3/4	121	2-5/8	67	3-7/8	98

C35-24(A/B), -30(A/B), -48(B/C), -50/60C and -60D Coils
 (NOTE - See next page for C35-48C-2F and C35-60C-2F Coils)

NOTE- C35-60D coil is positioned in cabinet with coil running left to right, all other coil sizes are positioned like drawing.

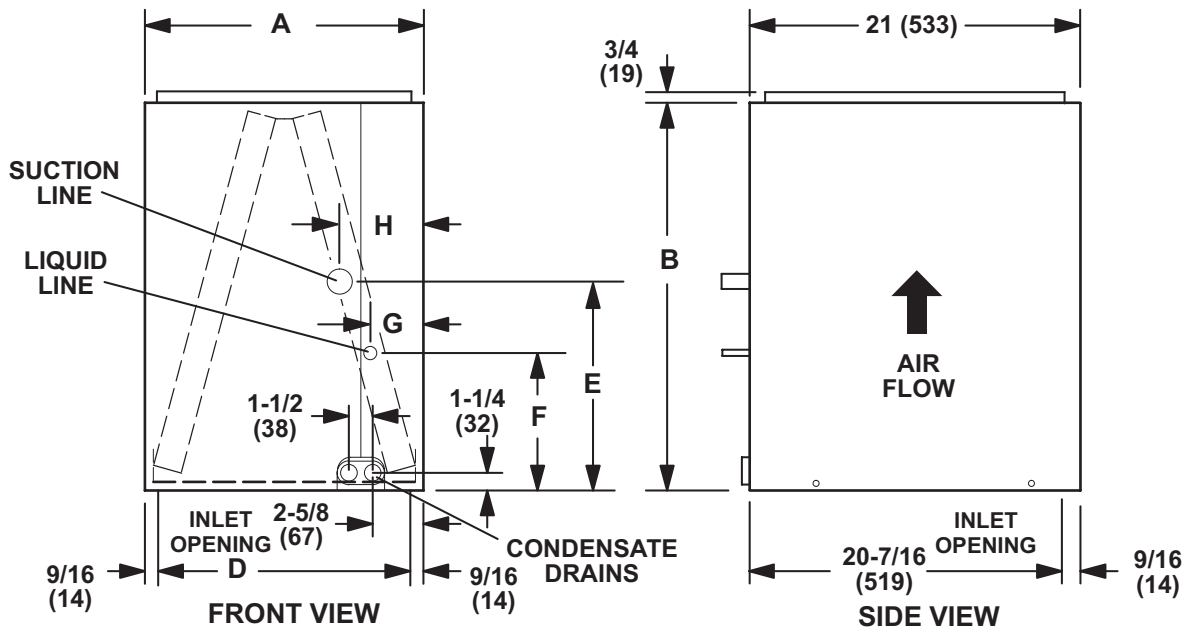
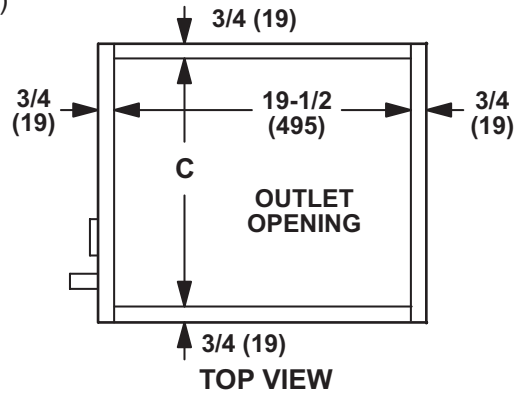

Model Number	A		B		C		D		E		F		G		H	
	in.	mm	in.	mm	in.	mm	in.	mm	in.	mm	in.	mm	in.	mm	in.	mm
C35-24A-2F	14-1/2	368	18-1/2	470	13	330	13-3/8	340	10-1/8	257	3-3/8	86	3	76	3-7/8	98
C35-24B-2F	17-1/2	445	18-1/2	470	16	406	16-3/8	416	10	254	3-1/2	89	3	76	3-7/8	98
C35-30A-2F	14-1/2	368	22-1/2	572	13	330	13-3/8	340	12	305	3-3/8	86	3	76	3-7/8	98
C35-30B-2F	17-1/2	445	22-1/2	572	16	406	16-3/8	416	10-1/2	267	3-3/8	86	3	76	3-7/8	98
C35-48B-2F	17-1/2	445	27-1/2	699	16	406	16-3/8	416	12-7/8	327	3-7/8	98	3	76	4	102
C35-48C-2F	21	533	27-1/2	699	19-1/2	495	19-7/8	505	12-1/2	318	4-3/4	121	2-3/4	70	3-1/2	89
C35-50/60C-2F	21	533	27-1/2	699	19-1/2	495	19-7/8	505	12-1/2	318	4-3/4	121	2-3/4	70	3-1/2	89
C35-60D-2F	24-1/2	622	29-1/2	749	23	584	23-3/8	594	15-1/8	384	4-1/2	121	1-5/8	41	2-5/8	67

C35-49C-2F and C35-60C-2F

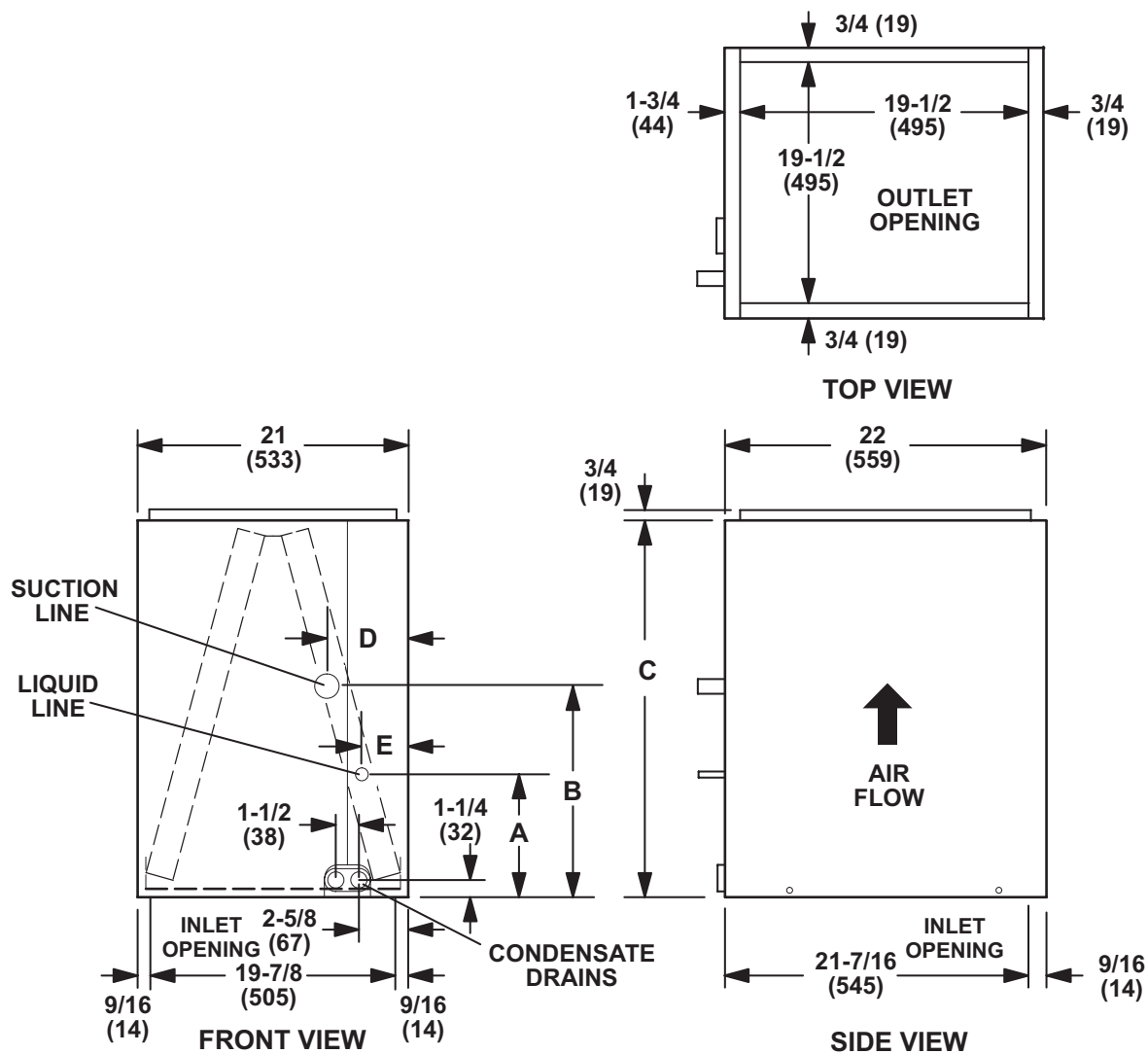

Model Number	A		B		C		D		E	
	in.	mm	in.	mm	in.	mm	in.	mm	in.	mm
C35-49C-2F	4-3/4	121	12-1/8	308	29-1/2	749	3-3/8	86	2-1/2	64
C35-60C-2F	4-3/4	121	14-1/2	368	31-1/2	800	3-3/8	86	2-1/2	64

DIMENSIONS - FURNACE/COIL COMBINED DIMENSIONS

UPFLOW POSITION

Model No	C35 Cased				C35 Uncased			
	A		B		A		B	
C35	in.	mm	in.	mm	in.	mm	in.	mm
C35-18/24A C35-18/24B	16-1/2	419	49-1/2	1257	14-1/8	359	47-1/8	1197
C35-24A C35-24B	18-1/2	470	51-1/2	1308	16-3/8	416	49-3/8	1254
C35-30A C35-30B	22-1/2	572	55-1/2	1410	20-3/4	527	53-3/4	1365
C35-30/36A C35-30/36B C35-30/36C	24-1/2	622	57-1/2	1461	22-1/4	565	55-1/4	1403
C35-36A C35-36B	24-1/2	622	57-1/2	1461	22-3/8	568	55-3/8	1407
C35-48B C35-48C	27-1/2	699	60-1/2	1537	26-1/4	667	59-1/4	1505
C35-49C	29-1/2	749	62-1/2	1588	28-1/2	724	61-1/2	1562
C35-50/60C	27-1/2	699	60-1/2	1537	25-7/8	657	58-7/8	1495
C35-60C	31-1/2	800	64-1/2	1638	30-5/8	778	63-5/8	1616
C35-60D	29-1/2	749	62-1/2	1588	28	711	61	1549

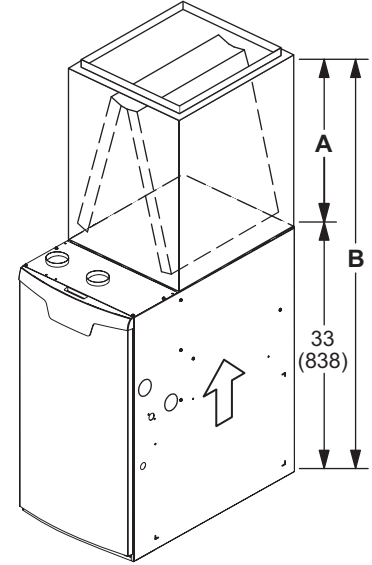

C33 TO C35 UNCASED COIL CROSS-REFERENCE

C33 Model No.	Tons	Dimensions (H x W x D)	Order No.	C35 Model No.	Tons	Dimensions (H x W x D)	Order No.
^{1,3} C33-18A-2	1.5	9.75 x 13 x 19.5	76L32	^{1,3} C35-18/24A-2	1.5 - 2	14.125 x 13 x 21.25	16F27
^{1,3} C33-24A-2	2	14 x 13 x 19.5	76L33	^{1,3} C35-18/24A-2	1.5 - 2	14.125 x 13 x 21.25	16F27
^{1,3} C33-24B-2	2	13.875 x 15.5 x 19.5	76L37	^{1,3} C35-18/24B-2	1.5 - 2	14.125 x 15.5 x 21.25	16F28
^{1,2,3} C33-24C-2	2	13.875 x 20 x 19.5	70M25	^{1,2,3} C35-18/24B-2	1.5 - 2	14.125 x 15.5 x 21.25	16F28
^{1,3} C33-19A-2	1.5	14 x 13 x 19.5	85M07	^{1,3} C35-24A-2	2	16.375 x 13 x 21.25	16F29
^{1,3} C33-25A-2	2	16.25 x 13 x 19.5	85M08	^{1,3} C35-24A-2	2	16.375 x 13 x 21.25	16F29
^{1,3} C33-25B-2	2	15.875 x 15.5 x 19.5	85M09	^{1,3} C35-24B-2	2	16.375 x 15.5 x 21.25	16F30
^{1,3} C33-31A-2	2.5	21.25 x 13 x 19.5	85M10	^{1,3} C35-30A-2	2.5	20.75 x 13 x 21.25	16F31
^{1,3} C33-31B-2	2.5	20.25 x 15.5 x 19.5	85M11	^{1,3} C35-30B-2	2.5	20.75 x 15.5 x 21.25	16F32
^{1,3} C33-30A-2	2.5	18 x 13 x 19.5	76L34	^{1,3} C35-30/36A-2	2.5 - 3	22.25 x 13 x 21.25	16F33
^{1,3} C33-36A-2	3	22.125 x 13 x 19.5	76L35	^{1,3} C35-30/36A-2	2.5 - 3	22.25 x 13 x 21.25	16F33
^{1,3} C33-30B-2	2.5	17.75 x 15.5 x 19.5	76L38	^{1,3} C35-30/36B-2	2.5 - 3	22.25 x 15.5 x 21.25	16F35
^{1,3} C33-36B-2	3	21.875 x 15.5 x 19.5	76L39	^{1,3} C35-30/36B-2	2.5 - 3	22.25 x 15.5 x 21.25	16F35
^{1,3} C33-30C-2	2.5	17.75 x 20 x 19.5	70M26	^{1,3} C35-30/36C-2	2.5 - 3	22.25 x 20 x 21.25	16F36
^{1,3} C33-36C-2	3	21.25 x 20 x 19.5	76L43	^{1,3} C35-30/36C-2	2.5 - 3	22.25 x 20 x 21.25	16F36
^{1,3} C33-38A-2	3	22.25 x 13 x 19.5	76L36	^{1,3} C35-36A-2	3	22.375 x 13 x 21.25	16F37
^{1,3} C33-38B-2	3	22 x 15.5 x 19.5	76L40	^{1,3} C35-36B-2	3	22.375 x 15.5 x 21.25	16F39
^{1,3} C33-42B-2	3.5	21.875 x 15.5 x 19.5	76L41	^{1,3} C35-48B-2	3.5 - 4	26.25 x 15.5 x 21.25	16F40
^{1,3} C33-43B-2	3.5	26.25 x 15.5 x 19.5	85M12	^{1,3} C35-48B-2	3.5 - 4	26.25 x 15.5 x 21.25	16F40
^{1,3} C33-48B-2	4	26.25 x 15.5 x 19.5	76L42	^{1,3} C35-48B-2	3.5 - 4	26.25 x 15.5 x 21.25	16F40
^{1,3} C33-43C-2	3.5	25.75 x 20 x 19.5	85M13	^{1,3} C35-48C-2	3.5 - 4	26.25 x 20 x 21.25	16F43
^{1,3} C33-44C-2	3.5 - 4	21.5 x 20 x 19.5	76L44	^{1,3} C35-48C-2	3.5 - 4	26.25 x 20 x 21.25	16F43
^{1,2,3} C33-48C-2	3.5 - 4	21.5 x 20 x 19.5	76L45	^{1,2,3} C35-49C-2	4	28.5 x 19.5 x 21.25	16F44
^{1,3} C33-49C-2	4	28.5 x 19.5 x 21.5	85M14	^{1,3} C35-49C-2	4	28.5 x 19.5 x 21.25	16F45
^{1,3} C33-50/60C-2	4 - 5	26.75 x 20 x 19.5	76L46	^{1,3} C35-50/60C-2	4 - 5	25.875 x 20 x 21.25	16F45
^{1,3} C33-62C-2	5	30.625 x 19.5 x 21.5	85M15	^{1,3} C35-60C-2	5	30.625 x 19.5 x 21.25	16F46
^{1,3} C33-60D-2	5	24.75 x 23 x 19.5	76L47	^{1,3} C35-60D-2	5	28 x 23 x 21.25	16F47
^{1,3} C33-62D-2	5	28.75 x 23 x 19.5	76L48	^{1,3} C35-60D-2	5	28 x 23 x 21.25	16F47

¹ Coil heights do not match between C33 and C35 models.

² Coil widths do not match between C33 and C35 models.

³ Coil depths do not match between C33 and C35 models.

C33 TO C35 CASED COIL CROSS-REFERENCE

C33 Model No.	Tons	Dimensions (H x W x D)	Order No.	C35 Model No.	Tons	Dimensions (H x W x D)	Order No.
¹ C33-18A-2F	1.5	12.5 x 14.5 x 21	54M79	¹ C35-18/24A-2F	1.5 - 2	16.5 x 14.5 x 21	10C61
C33-24A-2F	2	16.5 x 14.5 x 21	76L16	C35-18/24A-2F	1.5 - 2	16.5 x 14.5 x 21	10C61
C33-24B-2F	2	16.5 x 17.5 x 21	76L20	C35-18/24B-2F	1.5 - 2	16.5 x 17.5 x 21	10C62
² C33-24C-2F	2	16.5 x 21 x 21	70M23	² C35-18/24B-2F	1.5 - 2	16.5 x 17.5 x 21	10C62
¹ C33-19A-2F	1.5	16.5 x 14.5 x 21	84M98	¹ C35-24A-2F	2	18.5 x 14.5 x 21	10C63
C33-25A-2F	2	18.5 x 14.5 x 21	84M99	C35-24A-2F	2	18.5 x 14.5 x 21	10C63
C33-25B-2F	2	18.5 x 17.5 x 21	85M00	C35-24B-2F	2	18.5 x 17.5 x 21	10C64
C33-31A-2F	2.5	22.5 x 14.5 x 21	85M01	C35-30A-2F	2.5	22.5 x 14.5 x 21	10C67
C33-31B-2F	2.5	22.5 x 17.5 x 21	85M02	C35-30B-2F	2.5	22.5 x 17.5 x 21	10C68
¹ C33-30A-2F	2.5	20.5 x 14.5 x 21	76L17	¹ C35-30/36A-2F	2.5 - 3	24.5 x 14.5 x 21	10C69
C33-36A-2F	3	24.5 x 14.5 x 21	76L18	C35-30/36A-2F	2.5 - 3	24.5 x 14.5 x 21	10C69
¹ C33-30B-2F	2.5	20.5 x 17.5 x 21	76L21	¹ C35-30/36B-2F	2.5 - 3	24.5 x 17.5 x 21	10C70
C33-36B-2F	3	24.5 x 17.5 x 21	76L22	C35-30/36B-2F	2.5 - 3	24.5 x 17.5 x 21	10C70
¹ C33-30C-2F	2.5	20.5 x 21 x 21	70M24	¹ C35-30/36C-2F	2.5 - 3	24.5 x 21 x 21	10C71
C33-36C-2F	3	24.5 x 21 x 21	76L26	C35-30/36C-2F	2.5 - 3	24.5 x 21 x 21	10C71
C33-38A-2F	3	24.5 x 14.5 x 21	76L19	C35-36A-2F	3	24.5 x 14.5 x 21	10C72
C33-38B-2F	3	24.5 x 17.5 x 21	76L23	C35-36B-2F	3	24.5 x 17.5 x 21	10C73
¹ C33-42B-2F	3.5	24.5 x 17.5 x 21	76L24	¹ C35-48B-2F	3.5 - 4	27.5 x 17.5 x 21	10C74
C33-43B-2F	3.5	27.5 x 17.5 x 21	85M03	C35-48B-2F	3.5 - 4	27.5 x 17.5 x 21	10C74
¹ C33-48B-2F	4	24.5 x 17.5 x 21	76L25	¹ C35-48B-2F	3.5 - 4	27.5 x 17.5 x 21	10C74
C33-43C-2F	3.5	27.5 x 21 x 21	85M04	C35-48C-2F	3.5 - 4	27.5 x 21 x 21	10C75
¹ C33-44C-2F	3.5 - 4	24.5 x 21 x 21	76L27	¹ C35-48C-2F	3.5 - 4	27.5 x 21 x 21	10C75
^{1,3} C33-48C-2F	3.5 - 4	24.5 x 21 x 21	76L28	^{1,3} C35-49C-2F	4	29.5 x 21 x 22	10C77
C33-49C-2F	4	29.5 x 21 x 22	85M05	C35-49C-2F	4	29.5 x 21 x 22	10C77
C33-50/60C-2F	4- 5	27.5 x 21 x 21	54M80	C35-50/60C-2F	4 - 5	27.5 x 21 x 21	10C78
C33-62C-2F	5	31.5 x 21 x 22	85M06	C35-60C-2F	5	31.5 x 21 x 22	10C79
¹ C33-60D-2F	5	25.5 x 24.5 x 21	54M81	¹ C35-60D-2F	5	29.5 x 24.5 x 21	10C80
C33-62D-2F	5	29.5 x 24.5 x 21	54M82	C35-60D-2F	5	29.5 x 24.5 x 21	10C80

¹ Coil heights do not match between C33 and C35 models.

² Coil widths do not match between C33 and C35 models.

³ Coil depths do not match between C33 and C35 models.

REVISIONS

Sections	Description of Change
Dimensions	Drawings updated for uncased C35-49C and C35-60C (drain pan).



Visit us at www.Lennox.com

For the latest technical information, www.LennoxPros.com

Contact us at 1-800-4-LENNOX

NOTE - Due to Lennox' ongoing commitment to quality, Specifications, Ratings and Dimensions subject to change without notice and without incurring liability.

Improper installation, adjustment, alteration, service or maintenance can cause property damage or personal injury.

Installation and service must be performed by a qualified installer and servicing agency.

©2021 Lennox Industries, Inc.