

# LENNOX®

## CHA11-1853, CHA11-2753 & CHA11-3003 SINGLE PACKAGE AIR CONDITIONERS

\*180,000 to 280,000 Btuh (52.7 to 82.0 kW) Cooling Capacity  
47,400 to 307,000 Btuh (13.9 to 90.0 kW) Optional Electric Heat

\*ARI Standard 360 Ratings

Canadian Edition  
ENGINEERING DATA  
COOLING UNITS  
PACKAGED  
Page 31  
July 1988  
Supersedes March 1988

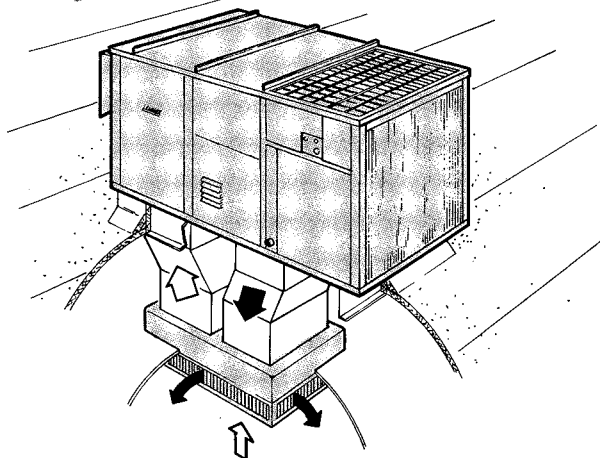
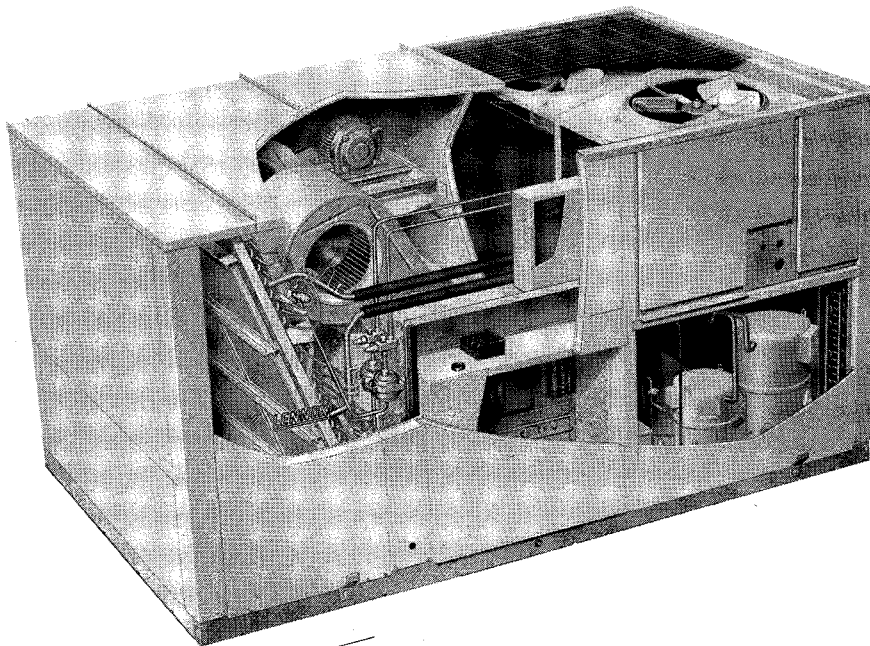

Rooftop Installation with  
Combination Ceiling Supply and Return Air System

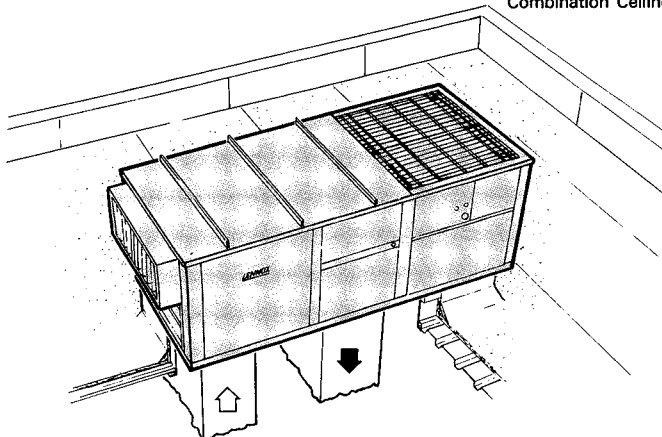

Rooftop Installation with  
Double Duct Distribution System

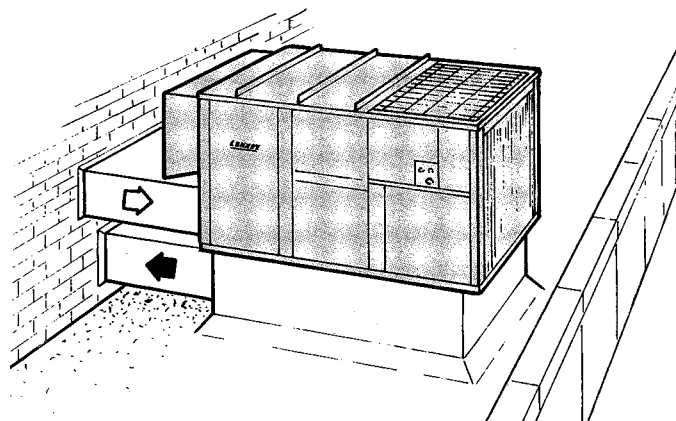

Rooftop Installation with  
Horizontal (End) Supply and Return Air System

NOTE - Specifications, Ratings and Dimensions subject to change without notice.

## FEATURES

**Applications** — The Lennox single package CHA11 units are designed for rooftop installation with bottom handling of supply and return air. A separate roof mounting frame (optional) mates to the bottom of the unit and when flashed into the roof permits weatherproof duct connections and entry into the conditioned area. Separate supply and return air double duct, combination ceiling supply and return air duct, or horizontal end duct systems are applicable to the units. A choice of RTD step-down or FD flush model diffusers are available for combination ceiling supply and return air distribution systems. Economizer dampers option will provide "free cooling" by using outdoor air in lieu of mechanical refrigeration. Units are available with optional electric heat. Thermostat and system controls are not furnished and must be ordered extra. Available as options are W973 control system, W7400 control system, electro-mechanical, Flexstat or T7300 thermostat control systems. Also available are LVAV Varizone® system controls. See Lennox Price Book. Units are shipped completely factory assembled, piped, and wired. In addition, each unit is test operated at the factory before shipment, insuring unit dependability.

**Approvals** — Units have been rated in the Lennox Research Laboratory environmental test room in accordance with ARI Standard 360-86. Units are C.G.A. listed and components within are bonded for grounding to meet safety standards for servicing required by Canadian Electrical Codes. Blower data is from tests conducted in the Lennox Laboratory air test chamber.

**Equipment Warranty** — Compressors have a limited warranty for a full five years. All other components have a limited warranty for one year. Refer to Lennox Equipment Limited Warranty certificate included with the unit for details.

**Refrigeration System** — Factory sealed refrigeration system consists of compressors, condenser coils and direct drive fans, evaporator (dual circuits) coil and blower, expansion valves, sight glasses, high capacity driers, high pressure switches, loss of charge switches, refrigerant lines connected and a full operating charge of refrigerant. Dual independent refrigerant circuits provide staging control to fit varying cooling loads. Lennox augments its reliable operating components with a full complement of standard comfort and safety controls.

**Durable Cabinet** — Rugged leaktight cabinet is constructed of heavy gauge galvanized steel. Cabinet is subject to a five station metal wash process resulting in a perfect bonding surface for a paint finish of powder enamel, electrostatically bonded to the metal. Base section and cabinet panels exposed to conditioned air are lined with thick fiberglass insulation. Insulation is sandwiched between the panel and a galvanized steel panel liner protecting the insulation indefinitely. Large removable panels allow complete service access. Electrical inlets are provided in the cabinet for wiring entry. Wiring junction box and control boxes with all controls factory installed are conveniently located for service access. Lifting brackets are furnished for ease of handling and rigging. Drainage holes in base rails provide moisture removal. Evaporator coil section drain connections are located on both sides of cabinet.

**Dual Compressors** — Two compressors in units provide staging control to fit varying cooling load requirements. Reliable compressors are hermetically sealed. Suction cooled, overload protected, and equipped with internal pressure relief valve. Internally protected from excessive current and temperature. Immersible self-regulating type crankcase heater is temperature actuated to operate only when required and ensures proper lubrication at all times. Conveniently located control box gives one spot servicing. The entire running gear is spring mounted within the sealed housing. In addition, the compressors are installed on resilient rubber mounts in the unit, assuring quiet and vibration free operation.

**Copper Tube Evaporator and Condenser Coils** — Extra large surface area and circuiting of coils provide maximum cooling efficiency, excellent heat transfer and low air resistance. Coils are constructed of precisely spaced ripple-edged aluminum fins fitted to durable copper tubes. Fins are equipped with collars that grip tubing for maximum contact area. Flared shoulder tubing connections and silver soldering provide tight, leakproof joints. Long life copper tubing is easy to field service. Coil is thoroughly factory tested under high pressure to insure leakproof construction. The evaporator coil is face split with two separate circuits. Each circuit has its separate expansion valve, compressor and refrigerant charge.

**Efficient Condenser Fans** — Two direct drive fans draw large air volumes uniformly through dual condenser coils and discharges it vertically, up and away from the building. Fan orifice design and low fan tip speed keeps operating sound level at a minimum. Uniform air flow through the coils results in high refrigerant cooling capacity. Permanently lubricated, overload protected fan motor is totally enclosed for maximum protection from rain, dust and corrosion. A rain shield on the motor provides additional protection from moisture. Motor is resiliently mounted. Corrosion resistant PVC coated steel wire fan guards are furnished.

**Powerful Dual Supply Air Blowers** — Twin belt drive centrifugal blowers deliver large air volume efficiently and with minimum power consumption. Blower assembly is mounted to rugged angle iron frame with the entire blower and frame assembly vibration isolated on rubber mounts. Ball bearings are permanently sealed and lubricated. Blower wheel is statically and dynamically balanced. Design of motor mounting base permits quick and simple motor changeover, belt tension adjustment or belt changing. A choice of motor outputs and drives is available. Adjustable motor pulley allows for variable speed adjustments. Motor is overload protected. See Blower Drive Selection table for motors and drives available.

**Air Filters** — One inch (25mm) thick frame type throwaway filters are furnished as standard. Fiberglass media is oil impregnated for increased efficiency. Filters are readily accessible for quick and simple replacement. Filter rack is designed to accept two inch (51mm) thick filters.

**Optional Electric Heat** — Available factory or field installed in 20 kW through 90 kW sizes. Helix wound nichrome heating elements are exposed directly in the air stream resulting in instant heat transfer, lower coil temperatures and long service life. Elements are accurately located and insulated from the heavy gauge steel support frame by high quality insulators. Time delays bring the elements on and off the line in sequence and equal increments in response to demand with a time delay between each element. Elements are equipped with individual limit controls providing positive protection in case of excessive temperatures. Heaters may be two stage controlled with each stage being energized only when required.

**Optional REMD11M Economizer Dampers** — Available factory or field installed. Lennox economizer system consists of: mechanically linked outdoor air and recirculated air dampers. Damper blades are gasketed for tight seal and quiet operation. Formed damper blades rotate smoothly in nylon bearings. The positioning of these dampers is accomplished by a 24 volt fully modulating spring return damper motor with adjustable minimum position potentiometer and controlled by the room thermostat, electronic discharge air sensor and solid-state adjustable outdoor air enthalpy control. An outdoor air hood with rain eliminator vanes is furnished and field installs over the outdoor air dampers external to the unit. For field installation the two damper sections slide in cavities provided in the unit cabinet. Economizer is shipped factory wired and only requires plug-in field connection. The enthalpy control allows for 0 to 100% outdoor air (first stage of cooling) to be used for "free cooling" when outdoor humidity and temperature are acceptable. Additionally, an integrated economizer cycle can be accomplished by allowing the outside air dampers to remain open, continuing to admit outside air, and cycling the compressors to provide dehumidification and additional cooling as needed. The integrated economizer cycle uses only the amount of mechanical cooling necessary.

## FEATURES

**Optional Differential Enthalpy Control** — A solid-state return air enthalpy sensor is available to be used in conjunction with the outdoor air enthalpy control to determine which air has the lowest enthalpy. The air with the lowest enthalpy will be selected. Return air enthalpy sensor (54G44) field installs in the economizer damper section and must be ordered extra.

**Optional GED11 Gravity Exhaust Air Dampers** — Dampers field install in space provided in the unit. Pressure operated extruded aluminum dampers rotate smoothly in nylon bearings. Damper blades are equipped with gaskets for tight seal and quiet operation.

**Optional PED11 Power Exhaust Dampers** — Field installs in space provided in the unit cabinet. Fans provide system pressure relief and are interlocked to run when return air dampers are closed and supply air blowers are operating. Motors are overload protected. Pressure operated extruded aluminum dampers ride in nylon bearings and are equipped with seal gaskets resulting in tight seal and quiet operation. Dampers prevent blow-back and outdoor air infiltration during off cycle.

**Optional OAD11 Minimum Fresh Air Dampers** — Damper section complete with cleanable polyurethane air filter field installs external to the unit cabinet. Available for manual or automatic operation. Damper assembly allows a fixed amount of outdoor air into the system and can be adjusted for air quantities up to 25%. Automatic damper operation is available with the addition of a spring return 3 position damper actuator. Actuator only requires plug-in connection for operation. Order Automatic Fresh Air Damper Kit 88G13.

**Optional RMF11 Standard Roof Mounting Frame** — Sturdy mounting frame mates to the unit and provides an automatic weather sealed roof-top installation. Shipped knocked down for ease of shipping and handling it is easily field assembled. A nailer strip is secured to the frame sides to facilitate flashing. Approved by National Roofing Contractors Association.

**Optional RMFH11 Horizontal Roof Mounting Frame** — Frame mates to CHA11 unit and provides horizontal end supply and return air (over/under) duct connection. Supply air connection is in end of frame. Return air connection is made at evaporator section end of unit. Shipped knocked down for ease of shipping and handling; it is easily field assembled. See dimension drawing.

**Optional RMFA11 Adapter Roof Mounting Frame** — Retrofit adapter frame is available for CHA11 model replacement of existing CHA8 unit installation. The frame adapts to the existing RMF3 frame and provides a weather sealed connection with minimum installation cost. Frame is shipped knocked down for ease of shipping and handling, it is easily field assembled. A nailer strip is secured to the frame sides to facilitate flashing. See dimension drawing and installation detail sketch.

**Optional RTD11 Combination Ceiling Supply and Return Diffuser Assembly** — Step down mount diffuser extends slightly below ceiling level and discharges conditioned air out through grilles on all four sides. Aluminum grilles are fitted with double deflection louvers for precise directional control of air flow. Return air enters through the large center grille. Assembly also includes insulated diffuser box with flanges for ease of duct connection, hanging rings for suspending and interior transition to insure low static and even air flow on all four sides. Transition is sealed internally to prevent recirculation. Diffuser assembly is completely factory assembled. Diffuser readily adapts to T-bar ceiling grids and plaster ceilings.

**Optional FD11 Combination Ceiling Supply and Return Diffuser Assembly** — Flush mount diffuser installs almost flush with the ceiling level and discharges conditioned air out through fixed blade louvers on all four sides. Fixed blade louvers insure that air flow will be evenly distributed. Return air enters through large center grille. Assembly also includes insulated diffuser box with flanges for ease of duct connections, support hanger eyelets at the top corners for secure installation and interior transition to insure low static and even air flow on all four sides. Transition is sealed internally to prevent recirculation. Diffuser assembly is completely factory assembled. Diffuser readily adapts to T-bar ceiling grids and plaster ceilings.

**Optional SRT11 Supply and Return Transitions** — Transitions field install in the RMF11 roof mounting frame and provide segregated and simple duct connections to supply and return diffuser. Completely insulated galvanized steel transitions have flanges for ease of duct connection. Duct from the transitions to the diffuser is not furnished and must be provided by installer. Transitions are completely factory assembled and easily field installed in the roof mounting frame with minimum costs and labor requirements.

**Optional Low Ambient Control Kit** — System will operate satisfactorily down to 50°F (10°C) outdoor air temperature without additional controls. If air conditioning operation is required at low ambients a field installed Low Ambient Kit (LB-57113BB) can be added enabling the unit to operate down to 0°F (-18°C).

**Optional SP11 Remote Status Panel** — The operation of the unit can be checked at a glance on the Remote Status Panel (12F83) conveniently located within the conditioned area. Signal lights on the panel indicate "Cool Mode", "Heat Mode", "Compressor 1", "Compressor 2", "No Heat" and "Filter." The Cool Mode signal light is green when lit and indicates economizer damper operation or DX cooling operation for units without the economizer. Heat Mode light is green and reflects heating operation. Compressor 1 and Compressor 2 lights are green when operating and will turn red if there is an operational malfunction. The No Heat and Filter lights will show red and indicate a requirement for service. The following field installed controls are required for use with the status panel and must be ordered extra. Filter Switch Kit (97C85) is required for operation of the filter light. Status Panel Readout Relay Kit (88G28) is required to interface status panel with unit operation.

**Optional SSP11 Remote Switching Status Panel** — The operation of the unit can be controlled and observed on the Switching Status Panel (12F84) conveniently located within the conditioned area. Signal lights on the panel indicate "Cool Mode", "Heat Mode", "Compressor 1", "Compressor 2", "No Heat" and "Filter". The Cool Mode signal light is green when lit and indicates economizer damper operation or DX cooling operation for units without the economizer. Heat Mode light is green and reflects heating operation. Compressor 1 and Compressor 2 lights are green when operating and will turn red if there is an operational malfunction. The No Heat and Filter lights will show red and indicate a requirement for service. Additionally, panel is equipped with a system selector switch (Off — Heat — Auto — Cool — Emergency Heat) (Heat Pump Only), fan switch (Auto — On) and after hours timer. Fan switch provides a choice of intermittent (Auto) or continuous (On) blower operation. Manually operated after hours timer (0 to 12 hours) overrides night setback controls providing normal operation for time period set. A momentary push button switch is used to initiate the timer period. The following field installed controls are required for use with the status panel and must be ordered extra. Filter Switch Kit (97C85) is required for operation of the filter light. Status Panel Readout Relay Kit (88G28) is required to interface status panel with unit operation.

## CONTROL SYSTEM OPTIONS

**Optional Electro-Mechanical Thermostat and Control System** — The thermostat and related controls of this system must be ordered extra for field installation. Two stage heat and two stage cool thermostat (13F06) with dual temperature selector levers. Uses subbase (13F17) with manual system switch (Off-Heat-Auto-Cool) and fan switch (Auto-On) or non-switching subbase (13F16). SP11 Remote Status Panel (12F83) or SSP11 Remote Switching Status Panel (12F84) is available for observing and controlling unit operation from the conditioned area. A SSP11 Relay Kit (41G39) is required for switching functions of the Switching Status Panel. Kit must be ordered extra and field installed. For nite operation the following are available. Single stage heating thermostat (13F12) and non-switching subbase (13F16). For applications without the economizer a Nite Kit (39G74), containing a plug-in relay, is required to override the operation of day thermostat. Two time clocks are available for the system. Automatic 7 day time clock programs a weekly schedule. Any day or days can be omitted. Each day of the week is clearly separated from every other day. Day and nite periods are distinctly marked. When the settings have been made the clock will turn the system on and off. Spaced in 2 hour increments and equipped with battery back-up in case of power outage. 24 hour nite setback time clock automatically programs the system to keep conditioned area at a more conservative temperature level (nite setback thermostat setting) during a period of vacancy. Spaced in 15 minute increments and equipped with battery back-up in case of power outage. See Price Book for time clock selection and catalog numbers. Also available is a Warm Up Kit (39G77) which holds the economizer outdoor air dampers closed during nite heat operation and morning warm up. See Flow Chart on page 36.

**Optional FLEXSTAT™ Thermostat and Control System** — The thermostat and related controls of this system must be ordered extra for field installation. Flexstat programmable thermostat (43G01) has touch sensitive keyboard, automatic switching from heat to cool, °C or °F readout, no anticipator, zero droop, indicator lights, hour/day programming, override capabilities, time readout, stage status indicators, operational mode symbols and battery back-up. A Remote Temperature Sensor (82F75) can be adapted to the thermostat for applications where it is desirable to locate the thermostat out of the conditioned area. SP11 Remote Status Panel (12F83) is available for checking unit operation from within the conditioned area. Also available is a Warm Up Kit (39G77) which holds the economizer outdoor air dampers closed during nite heat operation and morning warm up. See Flow Chart on page 37.

**Optional W973 Control System** — Control system must be ordered extra for field installation. Logic Panel (39G76) controls the operation of the economizer dampers and the stages of cooling and heating in response to a signal from the thermostat. To maintain stable temperatures the logic panel balances the conditioned space thermostat demand against the system output. System output is measured by a discharge sensor (furnished with the logic panel) located in the discharge air duct of the unit. The combined demand and output signals from the sensor determines economizer damper position and number of cooling or heating stages energized. The logic panel field installs in the unit or in a remote panel located within the conditioned space. W973 Plug-In Relay (furnished with the logic panel) is required to adapt the control system to the unit. Two thermostats are available for the system. Dual set point room thermostat (25C52) or transmitter (25C51) with a choice of remote sensors. Both have separate heating-cooling locking set points concealed under the cover and do not have indicating thermometer. The room thermostat has integral sensor and installs in the conditioned space. The transmitter installs outside the conditioned space with a Room Temperature Sensor (58C92) in the conditioned

area or a Return Air Temperature Sensor (27C40) in the return air duct of the unit. Thermostat and transmitter are furnished with a wiring wallplate. Also available is switching subbase (58C93) with system selector switch (Heat-Auto-Cool-Off) and fan switch (Auto-On). SP11 Remote Status Panel (12F83) or SSP11 Remote Switching Status Panel (12F84) is available for observing and controlling unit operation from the conditioned area. Two time clocks are available for the system. Automatic 7 day time clock programs a weekly schedule. Any day or days can be omitted. Each day of the week is clearly separated from every other day. Day and nite periods are distinctly marked. When the settings have been made the clock will turn the system on and off. Spaced in 2 hour increments and equipped with battery back-up in case of power outage. 24 hour nite setback time clock automatically programs the system to keep the conditioned area at a more conservative temperature level (nite set back thermostat setting) during a period of vacancy. Spaced in 15 minute increments and equipped with battery back-up in case of power outage. See Price Book for time clock selection and catalog numbers. Also available is a Warm Up Kit (39G77) which holds the economizer outdoor air dampers closed during nite heat operation and warm up. See Flow Chart on page 35.

**Optional W7400 Control System** — Control system must be ordered extra for field installation. Control Module (74G11) controls the operation of the economizer dampers and the stages of heating and cooling. Controlling input signals are setpoint, space temperature sensor and time-of-day scheduling from the thermostat. The control module balances the space temperature signal against the number of stages operating for system output. System output is measured and updated by monitoring the actual space temperature deviation from set point, and the rate of change of the space temperature. The control module field installs in the unit or in a remote panel located within the conditioned area. Two thermostats are available for the system. A room thermostat (36G63) with integral sensor that installs in the conditioned space or a remote thermostat (36G65) that installs outside the conditioned space with a Room Temperature Sensor (58C92) in the conditioned area or a Return Air Temperature Sensor (27C40) in the return air duct of the unit. Both thermostats are equipped with touch sensitive keyboard, automatic switching from heat to cool, no anticipator, zero droop, °C temperature readout, indicator lights, hour/day programming, override capabilities, time readout, stage status indicators, battery back-up and wiring wallplate. W7400 Plug-In Relay (furnished with the control module) provides separate set points for the economizer dampers and DX cooling. SP11 Remote Status Panel (12F83) is available for checking unit operation within the conditioned area. See Flow Chart on page 36.

**Optional T7300 Thermostat and Control System** — The thermostat and related controls of this system must be ordered extra for field installation. T7300 programmable thermostat (81G59) has internal or optional remote temperature sensing, touch sensitive keyboard, automatic switching from heat to cool, °F or °C temperature readout, no anticipator, droop/no droop selection, indicator LED's, hour/day programming, override capabilities, time readout, stage status indicators, operational mode readout and battery back-up. Switching subbase (81G60) features selectable output staging up to two heat and two cool, manual system switch (Heat-Off-Auto-Cool) and fan switch (Auto-On). Subbase also features an auxiliary relay output which controls economizer operation during occupied and unoccupied periods. Also available is a Room Temperature Sensor (58C92) for installation in the conditioned area when it is desirable to locate the thermostat out of the conditioned area and a Return Air Temperature Sensor (27C40) for installation in the return air duct of the unit. SP11 Status Panel (12F83) is available for checking unit operation from within the conditioned area. See Flow Chart on page 37.

# TEMPERATURE CONTROL SELECTION FLOW CHART

## OPTIONAL W973 CONTROL SYSTEM

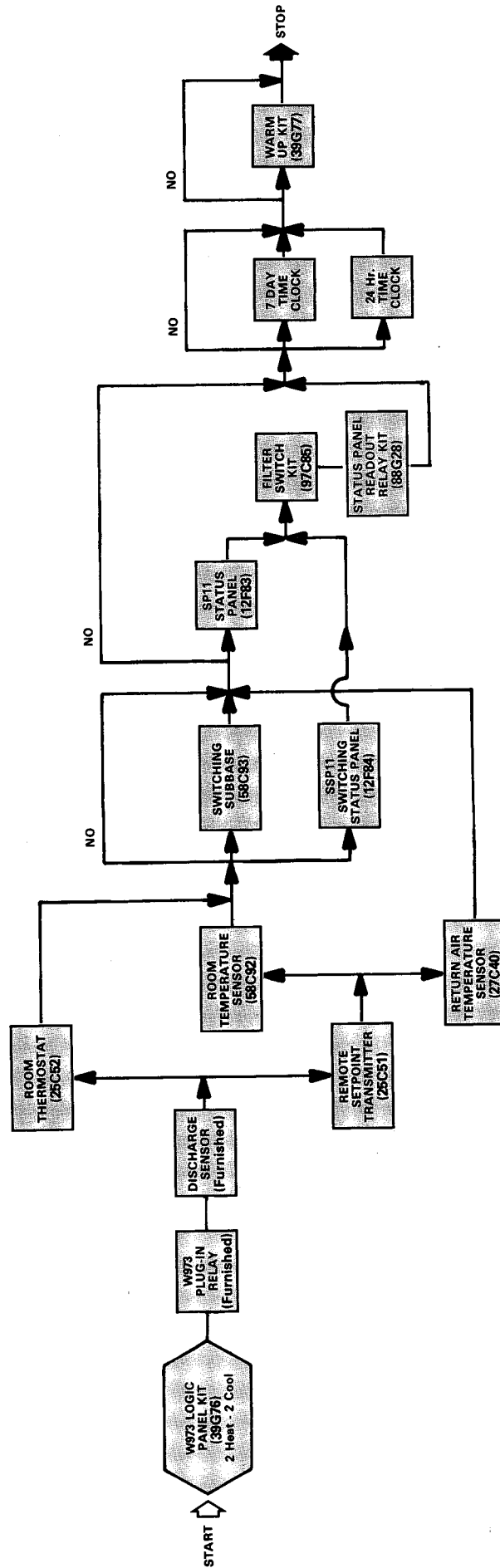

# TEMPERATURE CONTROL SELECTION FLOW CHART

## OPTIONAL ELECTRO-MECHANICAL THERMOSTAT CONTROL SYSTEM

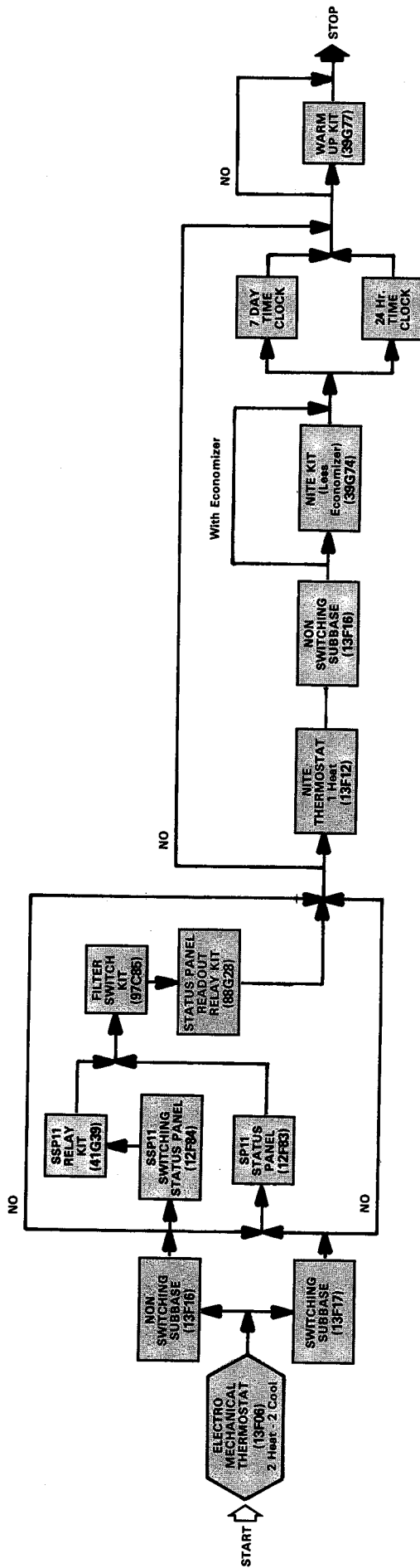

## OPTIONAL W7400 CONTROL SYSTEM

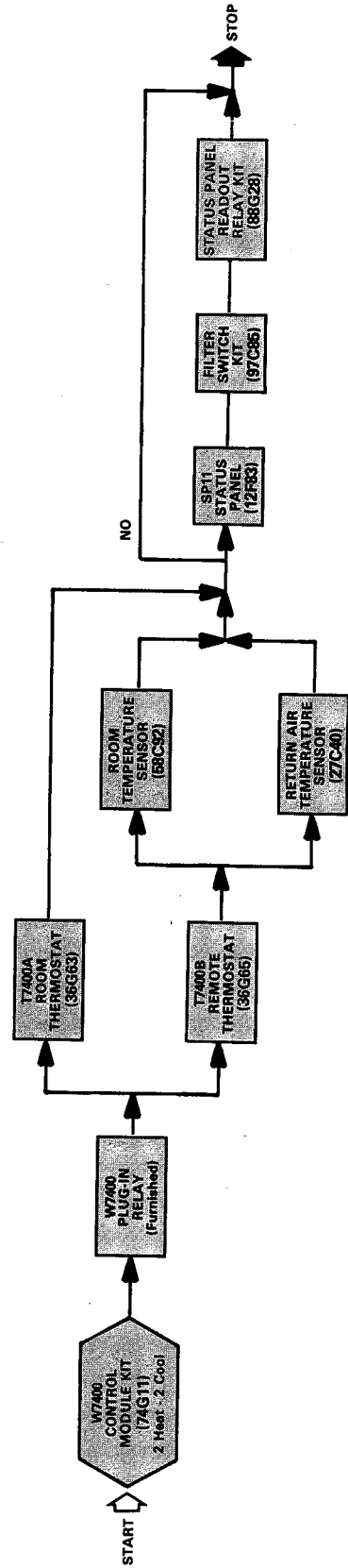

# TEMPERATURE CONTROL SELECTION FLOW CHART

## OPTIONAL FLEXSTAT THERMOSTAT CONTROL SYSTEM

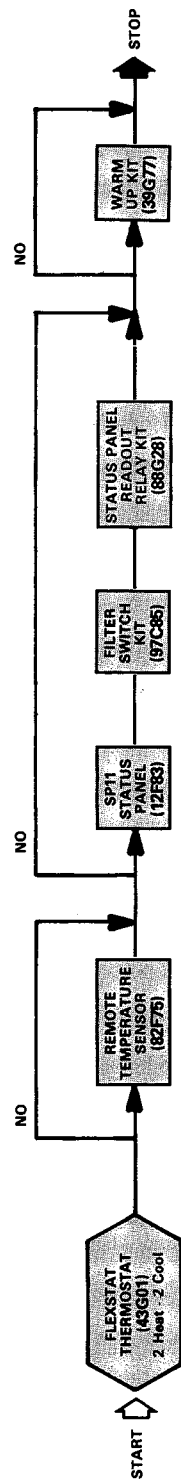

## OPTIONAL T7300 THERMOSTAT CONTROL SYSTEM

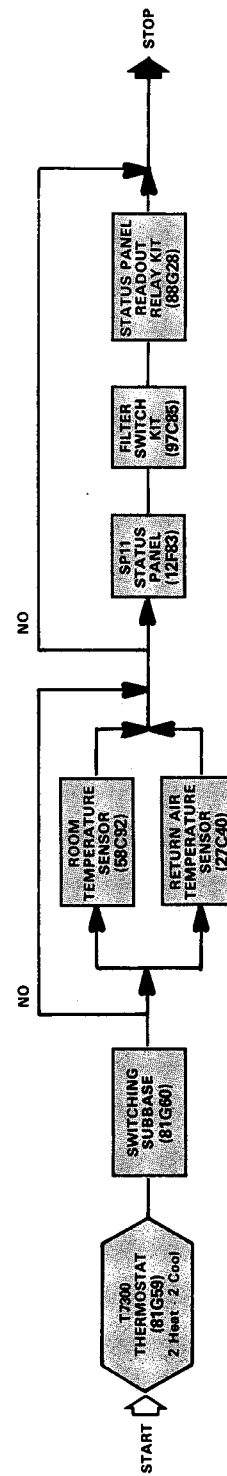

## SPECIFICATIONS

Model No.			CHA11-1853	CHA11-2753	CHA11-3003
*At ARI Standard 360 Ratings	Total cooling capacity — Btuh (kW)		180,000 (52.7)	240,000 (70.3)	280,000 (82.0)
	Total unit watts		21,900	28,800	34,200
	EER (Btuh/Watts)		8.2	8.3	8.20
	Integrated Part Load Value		8.6	8.3	---
Refrigerant (22) charge		Stage 1	18 lbs. 0 oz. (8.2 kg)	19 lbs. 0 oz. (8.6 kg)	19 lbs. 0 oz. (8.6 kg)
		Stage 2	8 lbs. 2 oz. (3.7 kg)	20 lbs. 8 oz. (9.3 kg)	20 lbs. 8 oz. (9.3 kg)
Evaporator Blower	Blower wheel nom. diam. x width	in.	(2) 15 x 9	(2) 15 x 15	(2) 15 x 15
		mm	(2) 381 x 229	(2) 381 x 381	(2) 381 x 381
		Motor horsepower (kW)	5 (3.7)	5 — 7-1/2 (3.7 — 5.6)	7-1/2 (5.6)
Evaporator Coil	Net face area — sq. ft. (m <sup>2</sup> )		17.2 (1.60)	23.5 (2.18)	23.5 (2.18)
	Tube diameter — in. (mm) & No. of rows		1/2 (13) — 3	1/2 (13) — 3	1/2 (13) — 4
	Fins per inch (m)		13 (510)	15 (590)	15 (590)
Condenser Coil	Net face area — sq. ft. (m <sup>2</sup> )		31.9 (2.96) (total)	38.9 (3.61)	38.9 (3.61)
	Tube diameter — in. (mm) & No. of rows		(1) 3/8 (10) — 3 (1) 3/8 (10) — 4	3/8 (10) — 4	3/8 (10) — 4
	Fins per inch (m)		20 (785)	20 (785)	18 (709)
Condenser Fans	Diameter — in. (mm) & No. of blades		(1) 24 (610) — 4 (1) 26 (660) — 5	(2) 26 (660) — 5	(2) 26 (660) — 5
	Air volume — cfm (L/s)		(1) 4400 (2076) (1) 6700 (3162)	(2) 6700 (3162)	(2) 7000 (3300)
	Motor horsepower (W)		(1) 1/2 (373), (1) 1 (746)	(2) 1 (746)	(2) 1 (746)
	Motor watts		(1) 550, (1) 1100	(2) 1050	(2) 1100
Condensate drain size mpt — in. (mm)			(2) 1-1/4 (31.6)	(2) 1-1/4 (31.6)	(2) 1-1/4 (31.6)
No. & size of filters		in.	(9) 16 x 20 x 1	(11) 16 x 20 x 1	(11) 16 x 20 x 1
		mm	(9) 406 x 508 x 25	(11) 406 x 508 x 25	(11) 406 x 508 x 25
Net weight of basic unit lbs. (kg) (1 Package)			2300 (1043)	2900 (1315)	2900 (1315)
Optional Electric Heat	Model No.		ECH11-185	ECH11-275	
	kW input range		20-30-45-60-75	30-45-60-75-90	
Optional Roof Mounting Frames (Net Weight) — lbs. (kg)		Standard	RMF11-185 — 265 (120)	RMF11-275 — 315 (143)	
		Horizontal	RMFH11-185 — 375 (170)	RMFH11-275 — 440 (200)	
		Adapter	RMFA11-185 — 470 (213)	RMFA11-275 — 510 (231)	
Optional Economizer & Controls (Net weight) — lbs. (kg)			REMD11M-185 — 235 (107)	REMD11M-275 — 290 (132)	
Optional Gravity Exhaust Damper (Net weight) — lbs. (kg)			GED11-185 — 25 (11)	GED11-275 — 30 (14)	
Optional Power Exhaust Dampers	Model No. (Net weight) — lbs. (kg)		PED11-185 — 110 (50)	PED11-275 — 150 (68)	
	Exhaust Fans	Diameter — in. (mm) & No. of blades	(2) 18 (457) — 5	(3) 18 (457) — 5	
		Total air volume — cfm (L/s)	5050 (2383)	7050 (3327)	
		Motor horsepower (W)	(2) 1/4 (187)	(3) 1/4 (187)	
		Total watts input	730	1100	
Optional Combination Ceiling Supply and Return Diffusers (Net weight) — lbs. (kg)		Step-down	RTD11-185 — 392 (178)	RTD11-275 — 403 (183)	
		Flush	FD11-185 — 289 (131)	FD11-275 — 363 (165)	
		Transitions	SRT11-185 — 70 (32)	SRT11-275 — 80 (36)	
Optional Fresh Air Damper	Model No. (Net weight) — lbs. (kg)		OAD11-185 — 90 (41)	OAD11-275 — 115 (52)	
	No. and size of filters	in.	(1) 25 x 27 x 1	(1) 26 x 31 x 1	
		mm	(1) 635 x 686 x 25	(1) 660 x 787 x 25	
Optional Automatic Damper Kit for OAD11 — (Net weight)			88G13 (15 lbs.) (7 kg)	88G13 (15 lbs.) (7 kg)	
Electrical characteristics			200 to 575 volt — 60 hertz — 3 phase		

\*Rated in accordance with ARI Standard 360; 95°F (35°C) outdoor air temperature and 80°F (27°C) db/67°F (18°C) wb entering evaporator air.



**CHA11-1853 OPTIONAL ELECTRIC HEAT DATA**

Electric Heat Model No. & Net Weight	No. of Steps	Volts Input	kW Input	Btuh Output	Total Unit & Electric Heat *Minimum Circuit Ampacity			
					5 hp (3730W)			
ECH11-185-20 (135 lbs.) (61 kg)	2	200	13.9	47,400	96			
		210	15.3	52,200				
		220	16.8	57,300				
		230	18.4	62,700				
	1	240	20.0	68,200	47			
		440	16.8	57,300				
		460	18.4	62,700				
	1	480	20.0	68,200	36			
		550	16.8	57,300				
		575	18.4	62,700				
ECH11-185-30 (135 lbs.) (61 kg)	2	200	20.8	71,000	96			
		210	23.0	78,500				
		220	25.2	86,000				
		230	27.5	93,900				
	1	240	30.0	102,400	108			
		440	25.2	86,000				
		460	27.5	93,900				
	1	480	30.0	102,400	52			
		550	25.0	85,300				
		575	27.6	94,200				
	1	600	30.0	102,400	42			
		200	31.3	106,800			135	
210		34.5	117,700					
220	37.8	129,000						
230	41.3	141,000						
ECH11-185-45 (145 lbs.) (66 kg)	3	240	45.0	153,600	152			
		440	37.8	129,000				
		460	41.3	141,000				
		480	45.0	153,600				
	2	550	37.5	123,000	74			
		575	41.3	141,000				
	2	600	45.0	153,600	59			
		200	41.7	142,300			174	
	4	210	46.0	157,000				
		220	50.4	172,000				
230		55.1	188,100					
240		60.0	204,800					
2	440	50.4	172,000	96				
	460	55.1	188,100					
	480	60.0	204,800					
	550	50.0	170,700					
2	575	55.1	188,100	77				
	600	60.0	204,800					
	200	52.1	177,700			213		
	5	210	57.4					196,000
220		63.0	215,000					
230		68.9	235,000					
240		75.0	255,900					
2	440	63.0	215,000	242				
	460	68.9	235,000					
	480	75.0	255,900					
	550	63.0	215,000					
3	460	68.9	235,000	118				
	480	75.0	255,900					
	550	63.0	215,000					
	575	68.9	235,000					
3	600	75.0	255,900	94				
	200	62.5	213,300			252	261	
	6	210	68.9					235,000
		220	75.6					258,000
230		82.7	282,000					
240		90.0	307,100					
3	440	75.6	258,000	286	294			
	460	82.7	282,000					
	480	90.0	307,100					
	550	75.6	258,000					
3	575	68.9	235,000	139	143			
	600	75.0	255,900					
	550	75.6	258,000					
	575	68.9	235,000					
3	600	90.0	307,100	111	114			
	200	62.5	213,300					
	6	210	68.9			235,000		
		220	75.6			258,000		
230		82.7	282,000					
3	240	90.0	307,100	286	294			
	440	75.6	258,000					
	460	82.7	282,000					
	480	90.0	307,100					
3	550	75.6	258,000	139	143			
	575	68.9	235,000					
	600	75.0	255,900					
	200	62.5	213,300					
6	210	68.9	235,000	252	261			
	220	75.6	258,000					
	230	82.7	282,000					
	240	90.0	307,100					
3	440	75.6	258,000	286	294			
	460	82.7	282,000					
	480	90.0	307,100					
	550	75.6	258,000					
3	575	68.9	235,000	139	143			
	600	75.0	255,900					
	550	75.6	258,000					
	575	68.9	235,000					
3	600	90.0	307,100	111	114			
	200	62.5	213,300					
	6	210	68.9			235,000		
		220	75.6			258,000		
230		82.7	282,000					
3	240	90.0	307,100	286	294			
	440	75.6	258,000					
	460	82.7	282,000					
	480	90.0	307,100					
3	550	75.6	258,000	139	143			
	575	68.9	235,000					
	600	75.0	255,900					
	200	62.5	213,300					
6	210	68.9	235,000	252	261			
	220	75.6	258,000					
	230	82.7	282,000					
	240	90.0	307,100					
3	440	75.6	258,000	286	294			
	460	82.7	282,000					
	480	90.0	307,100					
	550	75.6	258,000					
3	575	68.9	235,000	139	143			
	600	75.0	255,900					
	550	75.6	258,000					
	575	68.9	235,000					
3	600	90.0	307,100	111	114			
	200	62.5	213,300					
	6	210	68.9			235,000		
		220	75.6			258,000		
230		82.7	282,000					
3	240	90.0	307,100	286	294			
	440	75.6	258,000					
	460	82.7	282,000					
	480	90.0	307,100					
3	550	75.6	258,000	139	143			
	575	68.9	235,000					
	600	75.0	255,900					
	200	62.5	213,300					
6	210	68.9	235,000	252	261			
	220	75.6	258,000					
	230	82.7	282,000					
	240	90.0	307,100					
3	440	75.6	258,000	286	294			
	460	82.7	282,000					
	480	90.0	307,100					
	550	75.6	258,000					
3	575	68.9	235,000	139	143			
	600	75.0	255,900					
	550	75.6	258,000					
	575	68.9	235,000					
3	600	90.0	307,100	111	114			
	200	62.5	213,300					
	6	210	68.9			235,000		
		220	75.6			258,000		
230		82.7	282,000					
3	240	90.0	307,100	286	294			
	440	75.6	258,000					
	460	82.7	282,000					
	480	90.0	307,100					
3	550	75.6	258,000	139	143			
	575	68.9	235,000					
	600	75.0	255,900					
	200	62.5	213,300					
6	210	68.9	235,000	252	261			
	220	75.6	258,000					
	230	82.7	282,000					
	240	90.0	307,100					
3	440	75.6	258,000	286	294			
	460	82.7	282,000					
	480	90.0	307,100					
	550	75.6	258,000					
3	575	68.9	235,000	139	143			
	600	75.0	255,900					
	550	75.6	258,000					
	575	68.9	235,000					
3	600	90.0	307,100	111	114			
	200	62.5	213,300					
	6	210	68.9			235,000		
		220	75.6			258,000		
230		82.7	282,000					
3	240	90.0	307,100	286	294			
	440	75.6	258,000					
	460	82.7	282,000					
	480	90.0	307,100					
3	550	75.6	258,000	139	143			
	575	68.9	235,000					
	600	75.0	255,900					
	200	62.5	213,300					
6	210	68.9	235,000	252	261			
	220	75.6	258,000					
	230	82.7	282,000					
	240	90.0	307,100					
3	440	75.6	258,000	286	294			
	460	82.7	282,000					
	480	90.0	307,100					
	550	75.6	258,000					
3	575	68.9	235,000	139	143			
	600	75.0	255,900					
	550	75.6	258,000					
	575	68.9	235,000					
3	600	90.0	307,100	111	114			
	200	62.5	213,300					
	6	210	68.9			235,000		
		220	75.6			258,000		
230		82.7	282,000					
3	240	90.0	307,100	286	294			
	440	75.6	258,000					
	460	82.7	282,000					
	480	90.0	307,100					
3	550	75.6	258,000	139	143			
	575	68.9	235,000					
	600	75.0	255,900					
	200	62.5	213,300					
6	210	68.9	235,000	252	261			
	220	75.6	258,000					
	230	82.7	282,000					
	240	90.0	307,100					
3	440	75.6	258,000	286	294			
	460	82.7	282,000					
	480	90.0	307,100					
	550	75.6	258,000					
3	575	68.9	235,000	139	143			
	600	75.0	255,900					
	550	75.6	258,000					
	575	68.9	235,000					
3	600	90.0	307,100	111	114			
	200	62.5	213,300					
	6	210	68.9			235,000		
		220	75.6			258,000		
230		82.7	282,000					
3	240	90.0	307,100	286	294			
	440	75.6	258,000					
	460	82.7	282,000					
	480	90.0	307,100					
3	550	75.6	258,000	139	143			
	575	68.9	235,000					
	600	75.0	255,900					
	200	62.5	213,300					
6	210	68.9	235,000	252	261			
	220	75.6	258,000					
	230	82.7	282,000					
	240	90.0	307,100					
3	440	75.6	258,000	286	294			
	460	82.7	282,000					
	480	90.0	307,100					
	550	75.6	258,000					
3	575	68.9	235,000	139	143			
	600	75.0	255,900					
	550	75.6	258,000					
	575	68.9	235,000					
3	600	90.0	307,100	111	114			
	200	62.5	213,300					
	6	210	68.9			235,000		
		220	75.6			258,000		
230		82.7	282,000					
3	240	90.0	307,100	286	294			
	440	75.6	258,000					
	460	82.7	282,000					
	480							

## CHA11-1853 & 2753 ELECTRICAL DATA

Model No.		CHA11-1853				CHA11-2753								
Line voltage data — 60 hz — 3 phase		200V	230V	460V	575V	200V		230V		460V		575V		
Compressors (2)	Rated load amps (total)	39.5/20.9 (60.4)	39.5/19.0 (58.5)	20.4/10.0 (30.4)	15.0/7.5 (22.5)	39.5/39.5 (79.0)		39.5/39.5 (79.0)		20.4/20.4 (40.8)		15.0/15.0 (30.0)		
	Locked rotor amps (total)	229.0/158.0 (387.0)	229.0/158.0 (387.0)	116.0/82.0 (198.0)	91.0/39.0 (130.0)	229.0/229.0 (458.0)		229.0/229.0 (458.0)		116.0/116.0 (232.0)		90.5/90.5 (181.0)		
Condenser Fan Motors (2)	Full load amps (total)	9.4	8.2	4.3	3.5	12.8		10.4		5.6		4.6		
	Locked rotor amps (total)	21.2	20.2	9.8	7.7	30		28		13.2		9.6		
Evaporator Blower Motor	Motor Output	hp	5	5	5	5	5	7-1/2	5	7-1/2	5	7-1/2	5	7-1/2
		kW	3.7	3.7	3.7	3.7	3.7	5.6	3.7	5.6	3.7	5.6	3.7	5.6
	Full load amps (total)		17.5	15.2	7.6	5.9	17.5	25.3	15.2	22.0	7.6	11.0	5.9	8.5
	Locked rotor amps (total)		100.0	90.0	45.0	35.0	100.0	160.0	90.0	127.0	45.0	64.0	35.0	53.0
Optional Exhaust Fan Motors	Motor Output (No.)	hp	(2) — 1/4	(2) — 1/4	(2) — 1/4	(2) — 1/4	(3) — 1/4		(3) — 1/4		(3) — 1/4		(3) — 1/4	
		kW	(2) — 0.19	(2) — 0.19	(2) — 0.19	(2) — 0.19	(3) — 0.19		(3) — 0.19		(3) — 0.19		(3) — 0.19	
	Full load amps (total)		2.8	2.8	1.4	1.1	4.2		4.2		2.1		1.7	
	Locked rotor amps (total)		6.5	6.5	3.3	2.6	9.8		9.8		4.9		3.9	
Recom. max. fuse size (amps)	(With Exhaust Fans)	125	125	60	50	150	150	150	150	70	70	60	60	
Unit Power Factor	(With Exhaust Fans)	.86	.86	.86	.86	.88	.87	.88	.87	.88	.87	.88	.87	
*Minimum Circuit Ampacity	(With Exhaust Fans)	100.0	95.0	49.0	36.0	124.0	132.0	119.0	126.0	62.0	65.0	46.0	49.0	

\*Refer to Canadian Electrical Code manual to determine wire, fuse and disconnect size requirements.  
NOTE — Extremes of operating range are plus and minus 10% of line voltage.

## CHA11-3003 ELECTRICAL DATA

Model No.		CHA11-3003				
Line voltage data — 60 Hz — 3 phase		200V	230V	460V	575V	
Compressors (2)	Rated load amps (total)	50.2/50.2 (100.4)	50.2/50.2 (100.4)	25.1/25.1 (50.2)	19.8/19.8 (39.6)	
	Locked rotor amps (total)	220/220 (440.0)	220/220 (440.0)	110/110 (220.0)	74/74 (148.0)	
Condenser Fan Motors (2)	Full load amps (total)	12.8	10.4	5.6	4.6	
	Locked rotor amps (total)	30.0	28.0	13.2	9.6	
Evaporator Blower Motor	Motor Output	hp	7-1/2	7-1/2	7-1/2	
		kW	5.6	5.6	5.6	
	Full load amps (total)		25.3	22.0	11.0	8.5
	Locked rotor amps (total)		160	127	64	53
Optional Exhaust Fan Motors	Motor Output (Number)	hp	(3) — 1/4	(3) — 1/4	(3) — 1/4	
		kW	(3) — 0.19	(3) — 0.19	(3) — 0.19	
	Full load amps (total)		4.2	4.2	2.1	1.7
	Locked rotor amps (total)		9.75	9.75	4.9	3.9
Recommended Max. Fuse Size (Amps)	Less Exhaust Fans	200	175	90	70	
	With Exhaust Fans	200	175	100	70	
Unit Power Factor	Less Exhaust Fans	.84	.84	.84	.84	
	With Exhaust Fans	.85	.85	.85	.85	
Minimum Circuit Ampacity	Less Exhaust Fans	152.0	146.0	74.0	58.0	
	With Exhaust Fans	156.0	150.0	76.0	59.0	

\*Refer to Canadian Electric Code manual to determine wire, fuse and disconnect size requirements.  
NOTE — Extremes of operating range are plus and minus 10% of line voltage.

## FIELD WIRING W973 CONTROL SYSTEM

- A - Three wire power (See Electrical Data Table)
- B - Seven wire low voltage - DC only
- Five wire low voltage - DC only - with SSP11 Switching Status Panel
- Seven wire low voltage - DC only - with switching subbase
- C - Two wire low voltage - AC only - with switching subbase
- D - Two wire low voltage - DC only
- E - Nine wire low voltage - AC only
- F - Two wire power
- G - Two wire low voltage - AC only
- H - Thirteen wire low voltage - AC only
- J - Two wire low voltage - DC only

AC - Alternating current  
DC - Direct current

NOTE - Run separate harnesses for AC and DC.  
AC voltage interferes with DC signals.  
- Field wiring not furnished -

NOTE - All wiring must conform to CEC and local electrical codes.

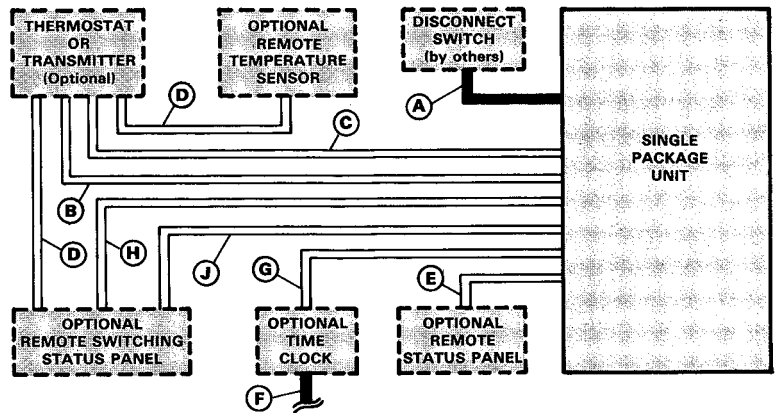

## ELECTRO-MECHANICAL THERMOSTAT CONTROL SYSTEM

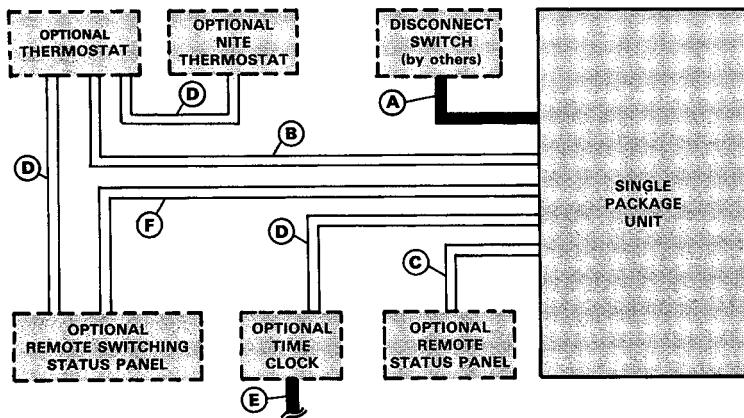

- A - Three wire power (See Electrical Data Table)
- B - Six wire low voltage
- Five wire low voltage - with SSP11 Switching Status Panel
- C - Nine wire low voltage
- D - Two wire low voltage
- E - Two wire power
- F - Fifteen wire low voltage

- Field wiring not furnished -

NOTE - All wiring must conform to CEC and local electrical codes.

## W7400 CONTROL SYSTEM

- A - Three wire power (See Electrical Data Table)
- B - Two wire low voltage
- C - Four wire low voltage
- D - Nine wire low voltage

- Field wiring not furnished -

NOTE - All wiring must conform to CEC and local electrical codes.

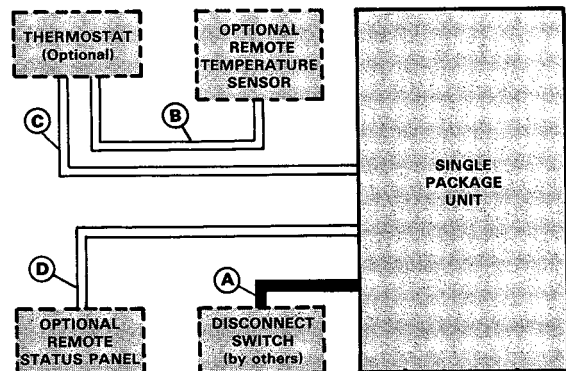

## FLEXSTAT OR T7300 THERMOSTAT CONTROL SYSTEM

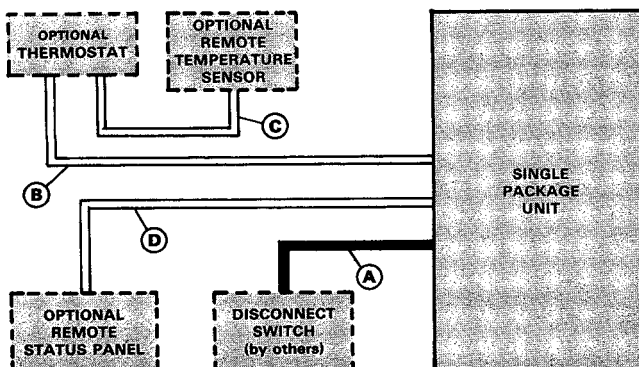

- A - Three wire power (See Electrical Data Table)
- B - Seven wire low voltage (Flexstat)
- Nine wire low voltage (T7300)
- C - Two wire low voltage
- D - Nine wire low voltage

- Field wiring not furnished -

NOTE - All wiring must conform to CEC and local electrical codes.

## COOLING RATINGS

NOTE — To determine sensible capacity, leaving wet bulb and dry bulb temperatures not shown in the tables, see Miscellaneous Engineering Data section, page 11.

### CHA11-1853 COOLING CAPACITY (With 10 Ton Compressor Only Operating)

Entering Wet Bulb Temperature	Total Air Volume		Outdoor Air Temperature Entering Condenser Coil																	
			65°F (18°C)					75°F (24°C)					85°F (29°C)							
			Total Cooling Capacity		Comp. Motor Watts Input	Sensible To Total Ratio (S/T)			Total Cooling Capacity		Comp. Motor Watts Input	Sensible To Total Ratio (S/T)			Total Cooling Capacity		Comp. Motor Watts Input	Sensible To Total Ratio (S/T)		
						Dry Bulb						Dry Bulb						Dry Bulb		
L/s	cfm	kW	Btuh	76°F 24°C	80°F 27°C	84°F 29°C	KW	Btuh	Input	76°F 24°C	80°F 27°C	84°F 29°C	kW	Btuh	Input	76°F 24°C	80°F 27°C	84°F 29°C		
63°F (17.2°C)	1574	5000	37.7	128,500	8930	.73	.82	.92	36.3	123,800	9740	.74	.84	.93	34.9	119,000	10,530	.75	.85	.95
	1967	6250	39.2	133,800	9130	.76	.87	.98	37.8	128,900	9950	.77	.88	.99	36.2	123,400	10,740	.78	.90	1.00
	2360	7500	40.6	138,400	9300	.80	.92	1.00	39.0	133,000	10,120	.81	.94	1.00	37.4	127,500	10,910	.83	.96	1.00
67°F (19.4°F)	1574	5000	40.9	139,400	9330	.58	.67	.76	39.4	134,300	10,170	.59	.68	.77	37.7	128,700	10,970	.59	.69	.79
	1967	6250	42.4	144,800	9530	.60	.70	.80	40.8	139,100	10,370	.61	.71	.82	39.0	133,100	11,170	.61	.73	.84
	2360	7500	43.7	149,200	9680	.62	.73	.85	41.9	143,000	10,530	.63	.75	.87	40.1	136,700	11,320	.64	.76	.89
71°F (21.7°C)	1574	5000	44.1	150,600	9730	.45	.54	.62	42.4	144,700	10,590	.46	.54	.63	40.6	138,600	11,400	.46	.55	.64
	1967	6250	45.7	155,900	9920	.46	.55	.65	43.9	149,700	10,780	.46	.56	.66	41.9	143,000	11,580	.46	.57	.67
	2360	7500	46.9	160,200	10,070	.47	.57	.68	45.0	153,500	10,930	.47	.58	.69	42.9	146,500	11,730	.48	.59	.71

### CHA11-1853 TOTAL COOLING CAPACITY (With Both Compressors Operating)

Entering Wet Bulb Temperature	Total Air Volume		Outdoor Air Temperature Entering Condenser Coil																	
			85°F (29°C)					95°F (35°C)					105°F (41°C)							
			Total Cooling Capacity		Comp. Motor Watts Input	Sensible To Total Ratio (S/T)			Total Cooling Capacity		Comp. Motor Watts Input	Sensible To Total Ratio (S/T)			Total Cooling Capacity		Comp. Motor Watts Input	Sensible To Total Ratio (S/T)		
						Dry Bulb						Dry Bulb						Dry Bulb		
L/s	cfm	kW	Btuh	76°F 24°C	80°F 27°C	84°F 29°C	KW	Btuh	Input	76°F 24°C	80°F 27°C	84°F 29°C	kW	Btuh	Input	76°F 24°C	80°F 27°C	84°F 29°C		
63°F (17.2°C)	2360	5000	52.3	178,400	15,780	.75	.85	.95	50.0	170,600	16,890	.76	.87	.97	47.6	162,300	17,880	.77	.89	1.00
	2950	6250	54.3	185,300	16,110	.78	.90	1.00	51.8	176,900	17,200	.80	.92	1.00	49.3	168,100	18,190	.82	.95	1.00
	3540	7500	56.0	191,200	16,370	.83	.96	1.00	53.5	182,400	17,480	.85	.98	1.00	50.8	173,500	18,460	.87	1.00	1.00
67°F (19.4°F)	2360	5000	56.6	193,000	16,460	.59	.69	.79	54.0	184,300	17,560	.60	.70	.80	51.3	175,100	18,550	.61	.72	.82
	2950	6250	58.5	199,700	16,750	.62	.73	.84	55.7	190,200	17,840	.62	.74	.86	52.8	180,300	18,820	.64	.76	.88
	3540	7500	60.1	205,000	16,970	.64	.76	.89	57.1	194,900	18,060	.65	.78	.91	54.1	184,500	19,030	.67	.81	.94
71°F (21.7°C)	2360	5000	60.9	207,900	17,100	.46	.55	.64	58.1	198,200	18,210	.46	.55	.65	55.1	188,100	19,200	.46	.56	.66
	2950	6250	62.9	214,500	17,380	.46	.57	.67	59.8	204,100	18,480	.47	.58	.69	56.7	193,300	19,450	.47	.59	.70
	3540	7500	64.4	219,700	17,590	.48	.59	.71	61.2	208,800	18,680	.48	.60	.73	57.9	197,400	19,640	.49	.62	.75

### CHA11-2753 COOLING CAPACITY (With One Compressor Only Operating)

Entering Wet Bulb Temperature	Total Air Volume		Outdoor Air Temperature Entering Condenser Coil																	
			65°F (18°C)					75°F (24°C)					85°F (29°C)							
			Total Cooling Capacity		Comp. Motor Watts Input	Sensible To Total Ratio (S/T)			Total Cooling Capacity		Comp. Motor Watts Input	Sensible To Total Ratio (S/T)			Total Cooling Capacity		Comp. Motor Watts Input	Sensible To Total Ratio (S/T)		
						Dry Bulb						Dry Bulb						Dry Bulb		
L/s	cfm	kW	Btuh	76°F 24°C	80°F 27°C	84°F 29°C	KW	Btuh	Input	76°F 24°C	80°F 27°C	84°F 29°C	kW	Btuh	Input	76°F 24°C	80°F 27°C	84°F 29°C		
63°F (17.2°C)	1652	7000	38.3	130,700	9060	.72	.82	.92	36.9	125,800	9890	.73	.84	.94	35.3	120,400	10,680	.75	.85	.96
	2006	8500	39.7	135,300	9240	.76	.87	.98	38.1	130,100	10,070	.77	.89	1.00	36.5	124,500	10,860	.78	.91	1.00
	2360	10,000	40.9	139,400	9390	.79	.92	1.00	39.2	133,900	10,220	.81	.94	1.00	37.5	128,100	11,020	.83	.96	1.00
67°F (19.4°F)	1652	7000	41.5	141,500	9460	.57	.67	.76	39.9	136,000	10,300	.58	.68	.78	38.1	130,000	11,100	.59	.69	.79
	2006	8500	42.8	146,000	9620	.59	.70	.80	41.0	139,900	10,470	.60	.71	.82	39.2	133,600	11,260	.61	.73	.84
	2360	10,000	43.8	149,600	9750	.62	.73	.85	42.0	143,200	10,600	.62	.75	.87	40.0	136,500	11,390	.64	.77	.89
71°F (21.7°C)	1652	7000	44.7	152,500	9860	.44	.53	.62	42.9	146,300	10,720	.45	.54	.63	40.9	139,700	11,520	.45	.54	.64
	2006	8500	46.0	156,900	10,010	.45	.55	.65	44.0	150,200	10,870	.45	.56	.66	42.0	143,300	11,670	.46	.57	.67
	2360	10,000	47.0	160,400	10,140	.46	.57	.68	45.0	153,500	10,990	.46	.58	.69	42.8	146,200	11,790	.47	.59	.71

### CHA11-2753 TOTAL COOLING CAPACITY (With Both Compressors Operating)

Entering Wet Bulb Temperature	Total Air Volume		Outdoor Air Temperature Entering Condenser Coil																	
			85°F (29°C)					95°F (35°C)					105°F (41°C)							
			Total Cooling Capacity		Comp. Motor Watts Input	Sensible To Total Ratio (S/T)			Total Cooling Capacity		Comp. Motor Watts Input	Sensible To Total Ratio (S/T)			Total Cooling Capacity		Comp. Motor Watts Input	Sensible To Total Ratio (S/T)		
						Dry Bulb						Dry Bulb						Dry Bulb		
L/s	cfm	kW	Btuh	76°F 24°C	80°F 27°C	84°F 29°C	KW	Btuh	Input	76°F 24°C	80°F 27°C	84°F 29°C	kW	Btuh	Input	76°F 24°C	80°F 27°C	84°F 29°C		
63°F (17.2°C)	3304	7000	70.6	241,000	21,360	.75	.85	.96	67.4	230,000	22,820	.76	.87	.98	64.0	218,400	24,150	.78	.90	1.00
	4012	8500	73.0	249,000	21,720	.79	.91	1.00	69.5	237,300	23,190	.80	.93	1.00	66.0	225,300	24,520	.82	.96	1.00
	4720	10,000	75.1	256,200	22,040	.83	.96	1.00	71.6	244,400	23,510	.85	.99	1.00	67.8	231,200	24,830	.87	1.00	1.00
67°F (19.4°F)	3304	7000	76.2	259,900	22,210	.59	.69	.79	72.5	247,500	23,680	.60	.70	.81	68.7	234,400	24,990	.61	.72	.83
	4012	8500	78.3	267,200	22,520	.61	.73	.84	74.4	253,900	23,980	.62	.74	.86	70.4	240,100	25,280	.64	.76	.89
	4720	10,000	80.0	273,100	22,770	.64	.77	.89	76.0	259,200	24,230	.65	.79	.92	71.7	244,700	25,520	.67	.81	.95
71°F (21.7°C)	3304	7000	81.9	279,500	23,050	.45	.54	.64	77.9	265,800	24,530	.45	.55	.65	73.7	251,500	25,840	.46	.56	.67
	4012	8500	84.0	286,600	23,340	.46	.57	.67	79.7	272,100	24,810	.46	.58	.69	75.3	257,100	26,100	.47	.59	.71
	4720	10,000	85.7	292,500	23,580	.47	.59	.71	81.3	277,300	25,030	.48	.60	.73	76.7	261,600	26,310	.48	.62	.75

## RATINGS

NOTE — To determine sensible capacity, leaving wet bulb and dry bulb temperatures not shown in the tables, see Miscellaneous Engineering Data, page 11.

### CHA11-3003 COOLING CAPACITY (With One Compressor Only Operating)

Entering Wet Bulb Temperature	Total Air Volume		Outdoor Air Temperature Entering Outdoor Coil																	
			65°F (18°C)					75°F (24°C)					85°F (29°C)							
			Total Cooling Capacity		Comp. Motor Watts Input	Sensible To Total Ratio (S/T)			Total Cooling Capacity		Comp. Motor Watts Input	Sensible To Total Ratio (S/T)			Total Cooling Capacity		Comp. Motor Watts Input	Sensible To Total Ratio (S/T)		
						Dry Bulb						Dry Bulb						Dry Bulb		
			cfm	m <sup>3</sup> /s	kW	Btuh	76°F 24°C	80°F 27°C	84°F 29°C	kW	Btuh	76°F 24°C	80°F 27°C	84°F 29°C	kW	Btuh	76°F 24°C	80°F 27°C	84°F 29°C	
63°F (17.2°C)	7000	3.30	45.0	153,400	11,000	.70	.79	.87	43.0	146,700	11,830	.71	.80	.89	40.9	139,600	12,610	.72	.82	.91
	8500	4.00	46.5	158,700	11,210	.73	.83	.93	44.4	151,600	12,060	.74	.85	.95	42.3	144,200	12,870	.76	.87	.97
	10,000	4.70	47.8	163,100	11,380	.76	.88	.98	45.6	155,700	12,300	.78	.90	1.00	43.4	148,100	13,090	.80	.92	1.00
67°F (19.4°C)	7000	3.30	48.1	164,000	11,410	.56	.65	.73	46.0	156,800	12,300	.57	.65	.74	43.7	149,200	13,150	.57	.67	.76
	8500	4.00	49.6	169,100	11,600	.58	.68	.77	47.3	161,500	12,520	.59	.69	.79	45.0	153,400	13,390	.60	.70	.81
	10,000	4.70	50.8	173,200	11,780	.60	.71	.82	48.4	165,100	12,700	.61	.72	.84	45.9	156,700	13,580	.62	.74	.86
71°F (21.7°C)	7000	3.30	51.3	174,900	11,840	.44	.52	.60	48.9	167,000	12,790	.44	.52	.61	46.6	159,000	13,710	.44	.53	.62
	8500	4.00	52.7	179,800	12,040	.45	.54	.63	50.3	171,700	13,010	.45	.54	.64	47.8	163,100	13,940	.45	.55	.65
	10,000	4.70	53.9	183,800	12,200	.45	.56	.66	51.3	175,200	13,100	.46	.57	.67	48.8	166,400	14,120	.46	.58	.69

### CHA11-3003 COOLING CAPACITY (With Both Compressors Operating)

Entering Wet Bulb Temperature	Total Air Volume		Outdoor Air Temperature Entering Outdoor Coil																	
			85°F (29°C)					95°F (35°C)					105°F (41°C)							
			Total Cooling Capacity		Comp. Motor Watts Input	Sensible To Total Ratio (S/T)			Total Cooling Capacity		Comp. Motor Watts Input	Sensible To Total Ratio (S/T)			Total Cooling Capacity		Comp. Motor Watts Input	Sensible To Total Ratio (S/T)		
						Dry Bulb						Dry Bulb						Dry Bulb		
			cfm	m <sup>3</sup> /s	kW	Btuh	76°F 24°C	80°F 27°C	84°F 29°C	kW	Btuh	76°F 24°C	80°F 27°C	84°F 29°C	kW	Btuh	76°F 24°C	80°F 27°C	84°F 29°C	
63°F (17.2°C)	7000	3.30	81.8	279,200	25,220	.72	.82	.91	77.5	264,600	26,690	.73	.84	.94	73.1	249,500	28,020	.75	.86	.96
	8500	4.00	84.5	288,400	25,740	.76	.87	.97	80.0	273,000	27,260	.77	.89	1.00	75.4	257,300	28,640	.79	.92	1.00
	10,000	4.70	86.8	296,100	26,180	.80	.92	1.00	82.1	280,300	27,750	.82	.95	1.00	77.5	264,600	29,170	.84	.98	1.00
67°F (19.4°C)	7000	3.30	87.4	298,300	26,300	.57	.67	.76	82.9	282,700	27,890	.58	.68	.78	78.1	266,400	29,340	.59	.69	.80
	8500	4.00	90.0	307,000	26,780	.60	.70	.81	85.0	290,200	28,410	.61	.72	.83	80.0	273,100	29,880	.62	.74	.86
	10,000	4.70	91.8	313,400	27,150	.62	.74	.86	86.8	296,200	28,800	.63	.76	.89	81.6	278,500	30,300	.65	.79	.92
71°F (21.7°C)	7000	3.30	93.2	318,100	27,410	.44	.53	.62	88.3	301,200	29,140	.45	.54	.63	83.3	284,100	30,720	.45	.55	.65
	8500	4.00	95.7	326,400	27,880	.45	.55	.65	90.5	308,800	29,640	.46	.56	.67	85.2	290,600	31,240	.46	.57	.69
	10,000	4.70	97.5	332,800	28,240	.46	.58	.69	92.2	314,600	30,020	.47	.59	.71	86.7	295,700	31,630	.48	.60	.73

## BLOWER DATA

### CHA11-1853 BLOWER PERFORMANCE

Air Volume cfm (L/s)	STATIC PRESSURE EXTERNAL TO UNIT — Inches Water Gauge (Pa)																					
	.20 (50)		.30 (75)		.40 (100)		.50 (125)		.60 (150)		.70 (175)		.80 (200)		.90 (225)		1.0 (250)		1.30 (325)		1.50 (375)	
	RPM	BHP (kW)	RPM	BHP (kW)	RPM	BHP (kW)	RPM	BHP (kW)	RPM	BHP (kW)	RPM	BHP (kW)	RPM	BHP (kW)	RPM	BHP (kW)	RPM	BHP (kW)	RPM	BHP (kW)	RPM	BHP (kW)
5000 (2360)	570	1.30 (.97)	600	1.50 (1.12)	640	1.70 (1.27)	680	1.90 (1.42)	710	2.10 (1.57)	740	2.30 (1.72)	770	2.50 (1.87)	805	2.70 (2.01)	830	2.90 (2.16)	915	3.65 (2.72)	990	4.20 (3.13)
5200 (2450)	580	1.45 (1.08)	620	1.65 (1.23)	655	1.85 (1.38)	690	2.10 (1.57)	720	2.30 (1.72)	755	2.50 (1.87)	780	2.70 (2.01)	815	2.95 (2.20)	840	3.15 (2.35)	925	3.90 (2.91)	1005	4.45 (3.32)
5400 (2550)	595	1.60 (1.19)	630	1.80 (1.34)	670	2.05 (1.53)	705	2.25 (1.68)	735	2.45 (1.83)	765	2.70 (2.01)	795	2.95 (2.20)	830	3.15 (2.35)	850	3.35 (2.50)	940	4.15 (3.10)	1015	4.70 (3.51)
5600 (2640)	610	1.80 (1.34)	645	2.00 (1.49)	680	2.20 (1.64)	715	2.45 (1.83)	740	2.65 (1.98)	780	2.90 (2.16)	810	3.15 (2.35)	840	3.40 (2.54)	865	3.60 (2.69)	950	4.40 (3.28)	1025	4.85 (3.62)
5800 (2740)	620	1.95 (1.45)	660	2.15 (1.60)	695	2.45 (1.83)	730	2.60 (1.94)	760	2.85 (2.13)	795	3.10 (2.31)	820	3.30 (2.46)	850	3.55 (2.65)	875	3.80 (2.83)	965	4.65 (3.47)	---	---
6000 (2830)	635	2.10 (1.57)	675	2.35 (1.75)	710	2.65 (1.98)	745	2.80 (2.09)	775	3.05 (2.28)	805	3.30 (2.46)	835	3.55 (2.65)	865	3.80 (2.83)	890	4.05 (3.02)	975	4.90 (3.66)	---	---
6200 (2930)	650	2.30 (1.72)	690	2.55 (1.90)	725	2.85 (2.13)	760	3.00 (2.24)	790	3.30 (2.46)	815	3.55 (2.65)	850	3.80 (2.83)	875	4.05 (3.02)	900	4.30 (3.21)	---	---	---	---
6400 (3020)	665	2.50 (1.87)	705	2.75 (2.05)	735	3.05 (2.28)	770	3.25 (2.42)	800	3.50 (2.61)	830	3.75 (2.80)	860	4.05 (3.02)	890	4.30 (3.21)	915	4.56 (3.40)	---	---	---	---
6600 (3110)	680	2.65 (1.98)	720	2.90 (2.16)	750	3.20 (2.39)	785	3.45 (2.57)	815	3.75 (2.80)	840	4.00 (2.98)	875	4.30 (3.21)	900	4.55 (3.39)	925	4.80 (3.58)	---	---	---	---
6800 (3210)	695	2.80 (2.09)	730	3.10 (2.31)	760	3.40 (2.54)	800	3.70 (2.76)	830	4.00 (2.98)	855	4.20 (3.13)	885	4.55 (3.39)	915	4.80 (3.58)	---	---	---	---	---	---
7000 (3300)	710	3.00 (2.24)	745	3.30 (2.46)	775	3.60 (2.69)	810	3.90 (2.91)	840	4.20 (3.13)	865	4.45 (3.32)	900	4.80 (3.58)	---	---	---	---	---	---	---	---
7200 (3400)	720	3.25 (2.42)	760	3.50 (2.61)	790	3.85 (2.87)	820	4.15 (3.10)	850	4.45 (3.32)	880	4.75 (3.54)	---	---	---	---	---	---	---	---	---	---
7400 (3490)	735	3.45 (2.57)	770	3.75 (2.80)	805	4.10 (3.06)	835	4.40 (3.28)	865	4.70 (3.51)	---	---	---	---	---	---	---	---	---	---	---	---

NOTE — Data is measured external to the unit cabinet with the air filter in place. See Page 45 for Accessory Air Resistance data.

# BLOWER DATA

## CHA11-2753 AND CHA11-3003 BLOWER PERFORMANCE

Air Volume cfm (L/s)	STATIC PRESSURE EXTERNAL TO UNIT — Inches Water Gauge (Pa)																						
	.20 (50)		.30 (75)		.40 (100)		.50 (125)		.60 (150)		.70 (175)		.80 (200)		.90 (225)		1.0 (250)		1.30 (325)		1.50 (375)		
	RPM	BHP (kW)	RPM	BHP (kW)	RPM	BHP (kW)	RPM	BHP (kW)	RPM	BHP (kW)	RPM	BHP (kW)	RPM	BHP (kW)	RPM	BHP (kW)	RPM	BHP (kW)	RPM	BHP (kW)	RPM	BHP (kW)	RPM
7000 (3300)	560	1.85 (1.38)	610	2.15 (1.60)	650	2.50 (1.87)	690	2.80 (2.09)	725	3.05 (2.28)	760	3.30 (2.46)	800	3.55 (2.65)	835	3.75 (2.80)	870	4.00 (2.98)	960	5.20 (3.88)	1015	5.90 (4.40)	
7200 (3400)	570	2.05 (1.53)	620	2.30 (1.72)	660	2.70 (2.01)	700	3.00 (2.24)	735	3.20 (2.39)	770	3.50 (2.61)	805	3.70 (2.76)	840	4.00 (2.98)	880	4.20 (3.13)	965	5.35 (3.99)	1020	6.10 (4.55)	
7400 (3490)	585	2.20 (1.64)	630	2.45 (1.83)	670	2.85 (2.13)	710	3.15 (2.35)	740	3.35 (2.50)	775	3.65 (2.72)	810	3.85 (2.87)	850	4.15 (3.10)	885	4.40 (3.28)	970	5.50 (4.10)	1025	6.25 (4.66)	
7600 (3590)	595	2.35 (1.75)	640	2.60 (1.94)	680	2.95 (2.20)	715	3.25 (2.42)	750	3.55 (2.65)	785	3.80 (2.83)	820	4.10 (3.06)	855	4.35 (3.25)	890	4.65 (3.47)	975	5.65 (4.21)	1030	6.45 (4.81)	
7800 (3680)	610	2.55 (1.90)	650	2.80 (2.09)	690	3.10 (2.31)	725	3.45 (2.57)	760	3.70 (2.76)	790	3.95 (2.95)	825	4.20 (3.13)	860	4.50 (3.36)	895	4.80 (3.58)	980	5.80 (4.33)	1035	6.65 (4.96)	
8000 (3780)	620	2.70 (2.01)	660	2.95 (2.20)	700	3.30 (2.46)	735	3.60 (2.69)	770	3.85 (2.87)	800	4.10 (3.06)	830	4.35 (3.25)	870	4.65 (3.47)	900	4.95 (3.69)	985	6.00 (4.48)	1040	6.80 (5.07)	
8200 (3870)	630	2.85 (2.13)	670	3.10 (2.31)	710	3.50 (2.61)	745	3.75 (2.80)	780	4.00 (2.98)	810	4.25 (3.17)	840	4.50 (3.36)	880	4.85 (3.62)	910	5.15 (3.84)	990	6.20 (4.63)	1045	7.00 (5.22)	
8400 (3960)	645	3.05 (2.28)	680	3.30 (2.46)	720	3.65 (2.72)	755	3.95 (2.95)	790	4.15 (3.10)	815	4.40 (3.28)	850	4.70 (3.51)	885	5.05 (3.77)	915	5.30 (3.95)	995	6.35 (4.74)	1050	7.15 (5.33)	
8600 (4060)	655	3.20 (2.39)	695	3.45 (2.57)	730	3.85 (2.87)	765	4.10 (3.06)	800	4.35 (3.25)	825	4.60 (3.43)	860	4.85 (3.62)	895	5.25 (3.92)	920	5.50 (4.10)	1000	6.55 (4.89)	1055	7.35 (5.48)	
8800 (4150)	670	3.40 (2.54)	705	3.65 (2.72)	740	4.00 (2.98)	775	4.30 (3.21)	805	4.50 (3.36)	830	4.75 (3.54)	865	5.05 (3.77)	900	5.40 (4.03)	930	5.65 (4.21)	1010	6.70 (5.00)	1060	7.50 (5.60)	
9000 (4250)	680	3.55 (2.65)	715	3.80 (2.83)	750	4.20 (3.13)	785	4.45 (3.32)	815	4.65 (3.47)	840	4.90 (3.66)	875	5.20 (3.88)	910	5.60 (4.18)	935	5.85 (4.36)	1015	6.90 (5.15)	----	----	
9200 (4340)	690	3.75 (2.80)	725	4.05 (3.02)	760	4.40 (3.28)	795	4.65 (3.47)	825	4.85 (3.62)	850	5.15 (3.84)	885	5.45 (4.07)	920	5.80 (4.33)	945	6.05 (4.51)	1020	7.15 (5.33)	----	----	
9400 (4440)	700	3.95 (2.95)	735	4.25 (3.17)	770	4.60 (3.43)	800	4.85 (3.62)	830	5.05 (3.77)	860	5.35 (3.99)	895	5.65 (4.21)	925	6.00 (4.48)	950	6.30 (4.70)	1030	7.40 (5.52)	----	----	
9600 (4530)	715	4.15 (3.10)	750	4.50 (3.36)	780	4.75 (3.54)	810	5.05 (3.77)	840	5.30 (3.95)	875	5.60 (4.18)	905	5.90 (4.40)	935	6.25 (4.66)	960	6.50 (4.85)	----	----	----	----	
9800 (4630)	725	4.35 (3.25)	760	4.70 (3.51)	785	4.95 (3.69)	815	5.15 (3.92)	850	5.50 (4.10)	885	5.80 (4.33)	915	6.10 (4.55)	940	6.45 (4.81)	965	6.75 (5.04)	----	----	----	----	
10,000 (4720)	735	4.55 (3.39)	770	4.95 (3.69)	795	5.15 (3.84)	825	5.45 (4.07)	855	5.70 (4.25)	895	6.05 (4.51)	925	6.35 (4.74)	950	6.65 (4.96)	975	6.95 (5.18)	----	----	----	----	

NOTE — Data is measured external to the unit cabinet with the air filter in place. See Page 45 for Accessory Air Resistance data.

### BLOWER DRIVE SELECTION

Using the total air volume and system Static Pressure External to Unit requirements needed, determine from the Blower Performance Chart necessary Rpm and motor size required for the job.

The following table lists the blower motor output and Rpm range of drives available with each motor. The correct motor and drive pulleys will be factory installed.

Model No.	Nominal Motor hp (W)	*Rpm Range Of All Available Drive Setups @ 1720 Rpm Motor Speed
CHA11-1853	5 (5730)	625-780
		815-970
CHA11-2753	5 (3730)	600-760
		790-965
	7-1/2 (5595)	900-1070
CHA11-3003	7-1/2 (5595)	900-1070

\*Specify exact Bhp (W), Rpm and power characteristics required when ordering.

### CEILING DIFFUSER AIR THROW DATA

Model No.	Air Volume		*Effective Throw Range			
	cfm	L/s	RTD11 Step Down		FD11 Flush	
			feet	meters	feet	meters
CHA11-1853	6000	2830	45-55	13.7-16.8	48-55	14.6-16.8
	6750	3190	47-56	14.3-17.1	50-58	15.2-17.7
	7500	3540	49-58	14.9-17.7	55-66	16.8-20.1
CHA11-2753 CHA11-3003	8000	3780	39-44	11.9-13.4	53-62	16.2-18.9
	9000	4250	47-56	14.3-17.1	55-64	14.6-19.5
	10,000	4720	49-58	14.9-17.7	57-67	17.4-20.4

\*Throw is the horizontal or vertical distance an air stream travels on leaving the outlet of diffuser before the maximum velocity is reduced to 50 ft. (15m) per minute.

### POWER EXHAUST FANS PERFORMANCE

#### CHA11-1853

Air Volume Exhausted		Return Air System Static Pressure	
cfm	L/s	inches water gauge	Pa
5050	2380	0	0
4750	2240	.05	12
4400	2080	.10	25
4100	1930	.15	37
3750	1770	.20	50
3450	1630	.25	62

#### CHA11-2753 AND CHA11-3003

Air Volume Exhausted		Return Air System Static Pressure	
cfm	L/s	inches water gauge	Pa
7050	3830	0	0
6550	3090	.05	12
6100	2880	.10	25
5600	2640	.15	37
5100	2410	.20	50
4600	2170	.25	62

## BLOWER DATA ACCESSORY AIR RESISTANCE

Model No.	Air Volume		Total Air Resistance — inches water gauge (Pa)					
			REMD11M Econo-mizer	RTD11 Diffuser			FD11 Diffuser	Electric Heater All Models
	cfm	L/s		2 Sides Open	3 Sides Open	4 Sides Open		
CHA11-1853	5000	2360	.038 (9)	.53 (132)	.44 (109)	.38 (94)	.27 (67)	.04 (10)
	5200	2450	.039 (10)	.57 (142)	.49 (122)	.41 (102)	.30 (75)	.04 (10)
	5400	2550	.041 (10)	.61 (152)	.52 (129)	.45 (112)	.33 (82)	.04 (10)
	5600	2640	.042 (10)	.66 (164)	.56 (139)	.48 (119)	.36 (90)	.04 (10)
	5800	2740	.044 (11)	.71 (177)	.59 (147)	.51 (127)	.39 (97)	.05 (12)
	6000	2830	.045 (11)	.76 (189)	.63 (157)	.55 (137)	.42 (104)	.05 (12)
	6200	2930	.047 (12)	.80 (199)	.68 (169)	.59 (147)	.46 (114)	.05 (12)
	6400	3020	.048 (12)	.86 (214)	.72 (179)	.63 (157)	.50 (124)	.05 (12)
	6600	3110	.050 (12)	.92 (229)	.77 (191)	.67 (167)	.54 (134)	.06 (15)
	6800	3210	.052 (13)	.99 (246)	.83 (206)	.72 (179)	.58 (144)	.06 (15)
	7000	3300	.054 (13)	1.03 (256)	.87 (216)	.76 (189)	.62 (154)	.06 (15)
	7200	3400	.056 (14)	1.09 (271)	.92 (229)	.80 (199)	.66 (164)	.06 (15)
	7400	3490	.058 (14)	1.15 (286)	.97 (241)	.84 (209)	.70 (174)	.06 (15)
CHA11-2753 CHA11-3003	7000	3300	.033 (8)	.42 (104)	.34 (85)	.31 (77)	.36 (90)	.06 (15)
	7200	3400	.035 (9)	.45 (112)	.37 (92)	.32 (80)	.38 (94)	.07 (17)
	7400	3490	.036 (9)	.48 (119)	.39 (97)	.35 (87)	.40 (99)	.07 (17)
	7600	3590	.038 (9)	.51 (127)	.42 (104)	.37 (92)	.43 (107)	.07 (17)
	7800	3680	.039 (10)	.55 (137)	.46 (114)	.40 (99)	.47 (117)	.08 (20)
	8000	3780	.041 (10)	.58 (144)	.49 (122)	.43 (107)	.48 (119)	.08 (20)
	8200	3870	.043 (11)	.63 (157)	.53 (132)	.46 (114)	.53 (132)	.08 (20)
	8400	3960	.045 (11)	.67 (167)	.56 (139)	.49 (122)	.56 (139)	.09 (22)
	8600	4060	.047 (12)	.71 (177)	.60 (149)	.52 (129)	.59 (147)	.09 (22)
	8800	4150	.048 (12)	.73 (181)	.63 (157)	.55 (137)	.63 (157)	.10 (25)
	9000	4250	.050 (12)	.79 (196)	.67 (167)	.58 (144)	.66 (164)	.10 (25)
	9200	4340	.052 (13)	.84 (209)	.70 (174)	.61 (152)	.69 (172)	.11 (27)
	9400	4440	.054 (13)	.87 (216)	.73 (181)	.64 (159)	.72 (179)	.11 (27)
	9600	4530	.055 (14)	.92 (229)	.77 (191)	.67 (167)	.75 (186)	.12 (30)
	9800	4620	.057 (14)	.96 (239)	.81 (201)	.70 (174)	.78 (194)	.12 (30)
10,000	4720	.059 (15)	1.00 (249)	.84 (209)	.73 (182)	.81 (201)	.13 (32)	

### INSTALLATION CLEARANCES — inches (mm)

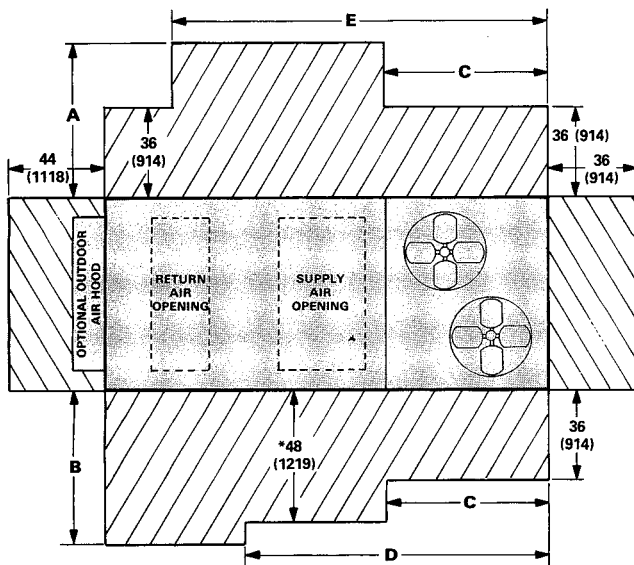

NOTE — Top Clearance Unobstructed.

\*May be 36 inches (914mm) without electric heat.

Model No.		A	B	C	D	E
CHA11-1853	in.	44	64	44	80	86
	mm	1118	1626	1118	2032	2184
CHA11-2753	in.	50	74	62	100	106
	mm	1270	1880	1575	2540	2692

# DIMENSIONS — inches (mm)

## CORNER WEIGHTS

Model No.		Q	R	S	T	
CHA11-1853	Basic Unit	lbs.	668	576	489	567
		kg	303	261	222	257
	With Economizer	lbs.	744	605	532	654
		kg	337	274	241	297
	With Economizer/Exhaust Fans	lbs.	764	621	565	695
		kg	347	282	256	315
CHA11-2753 CHA11-3003	Basic Unit	lbs.	787	729	665	719
		kg	357	331	302	326
	With Economizer	lbs.	875	770	723	821
		kg	397	349	328	372
	With Economizer/Exhaust Fans	lbs.	904	795	768	873
		kg	410	361	348	396

## CENTER OF GRAVITY

Model No.		U	V
CHA11-1853	Basic Unit	in.	31-1/2 53-1/2
		mm	800 1359
	With Economizer	in.	30-1/2 54-1/2
		mm	775 1384
	With Economizer/Exhaust Fans	in.	30-1/2 55-1/2
		mm	775 1410
CHA11-2753 CHA11-3003	Basic Unit	in.	37-1/2 67-3/4
		mm	953 1721
	With Economizer	in.	36-1/2 68-3/4
		mm	927 1746
	With Economizer/Exhaust Fans	in.	36-1/2 69-3/4
		mm	927 1772

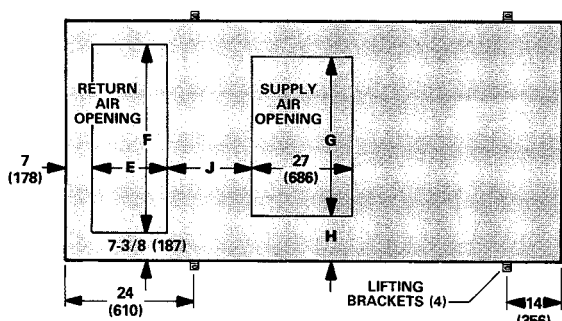

TOP VIEW BASE SECTION

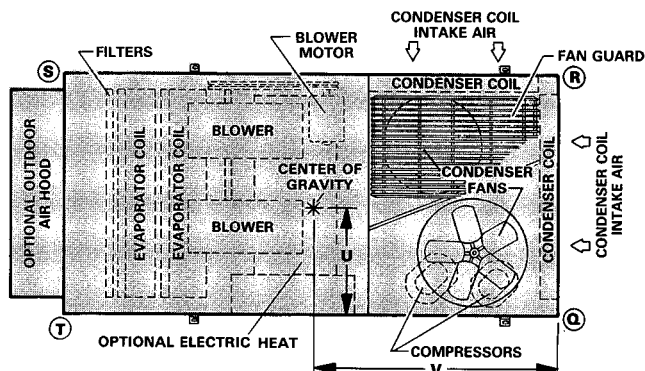

TOP VIEW

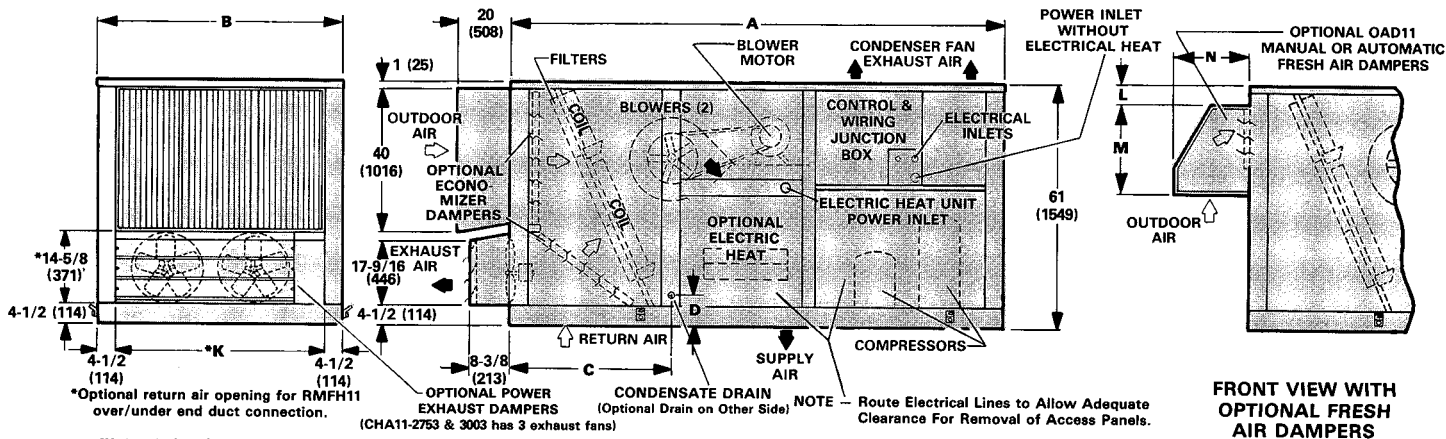

EXHAUST & OUTDOOR AIR INTAKE VIEW

FRONT VIEW

FRONT VIEW WITH OPTIONAL FRESH AIR DAMPERS

Model No.		A	B	C	D	E	F	G	H	J	K	L	M	N
CHA11-1853	in.	116-1/2	68	32-7/8	8-5/16	18	53-5/8	47	10-1/2	19-1/4	58-3/4	1-5/8	27-1/2	22-1/4
	mm	2959	1727	835	211	457	1362	1194	267	489	1365	41	699	565
CHA11-2753	in.	142	78	41	2-3/4	22-1/2	63-5/8	53	12-1/2	20-3/4	68-3/4	7-3/8	33-1/4	24-1/4
CHA11-3003	mm	3607	1981	1041	70	572	1616	1346	318	527	1746	187	845	616



## TYPICAL FLASHING FOR RMF11 ROOF MOUNTING FRAME

### ROOF MOUNTING FRAME SPECIFICATIONS.

Roof Mounting Frame is rigid enough to be spanned over its entire length or cantilevered if supported on either side of the center or gravity.

Mounting Frame Height		RMF11	RMFH11
*Frame moment of inertia $\frac{I}{C}$	in. <sup>4</sup>	68	517
	cm <sup>4</sup>	2831	21,522
*Frame section modulus $\frac{I}{C}$	in. <sup>3</sup>	10.0	36.8
	cm <sup>3</sup>	164	604
Mounting frame weight (length)	lb./ft.	9.8	13.5
	kg/m	14.6	20.1
Mounting frame design strength	psi	20,000	20,000
	kPa	137,900	137,900

\*Includes both sides of frame.

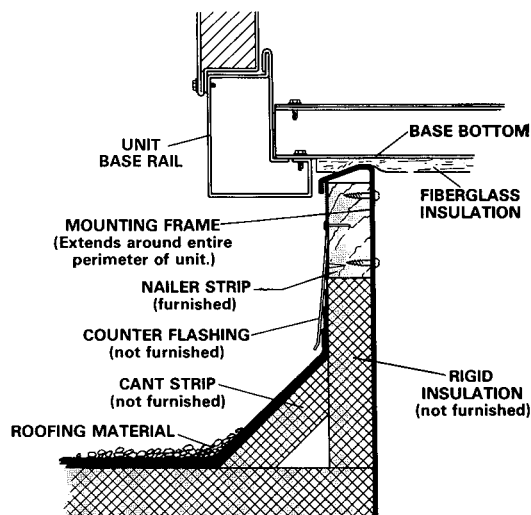

### DIMENSIONS — inches (mm)

#### RMF11 STANDARD ROOF MOUNTING FRAME WITH DOUBLE DUCT OPENING

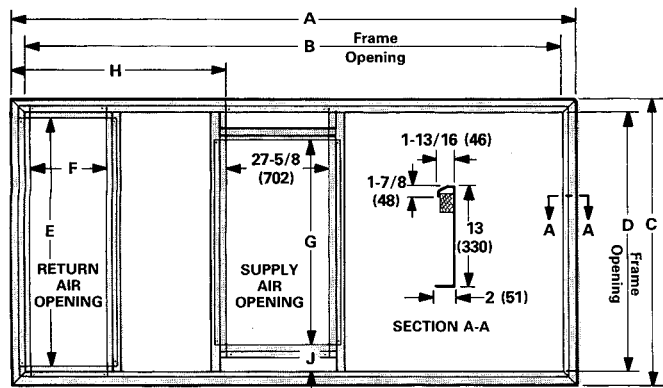

#### PLENUM SUPPORT ANGLE DETAIL

NOTE — Plenum support angles (furnished) must be field installed around perimeter of both supply and return air openings.

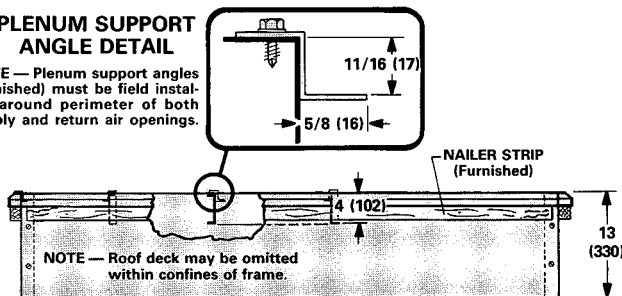

Model No.		A	B	C	D	E	F	G	H	J
RMF11-185	in.	107-3/4	104-1/8	59-1/4	55-5/8	54-1/4	18-5/8	47-5/8	40-9/16	4
	mm	2737	2645	1505	1413	1378	473	1210	1030	102
RMF11-275	in.	133-5/16	129-11/16	69-1/4	65-5/8	64-1/4	23-1/8	53-5/8	45-15/16	6
	mm	3386	3294	1759	1667	1632	587	1362	1167	152

#### RMF11 STANDARD ROOF MOUNTING FRAME WITH SUPPLY AND RETURN TRANSITIONS FOR FD11 & RTD11-185 & -275 DIFFUSERS

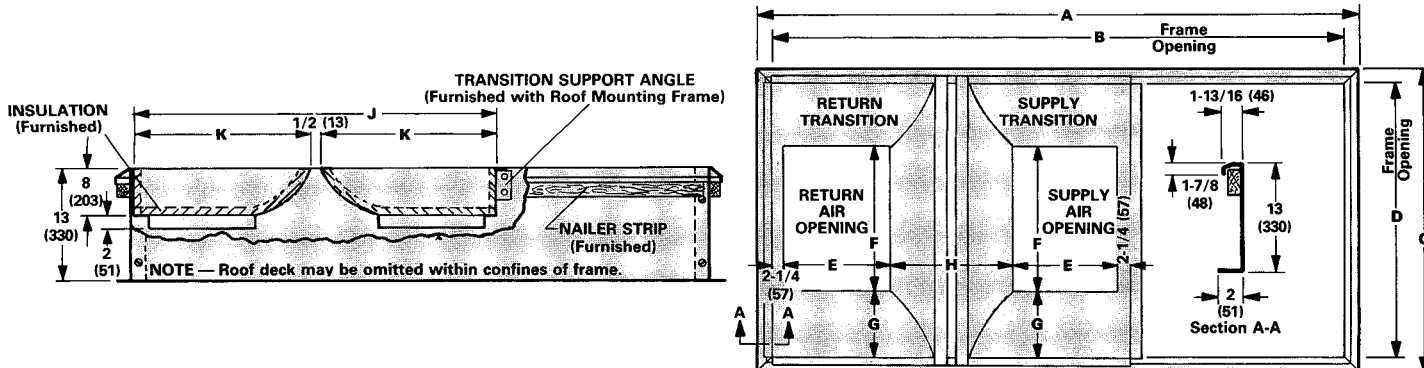

Model No.		A	B	C	D	E	F	G	H	J	K
RMF11-185	in.	107-3/4	104-1/8	59-1/4	55-5/8	18	36	9-13/16	25-3/4	66-1/4	32-7/8
	mm	2737	2645	1505	1413	457	914	249	654	1683	835
RMF11-275	in.	133-5/16	129-11/16	69-1/4	65-5/8	24	48	8-13/16	19-3/4	72-1/4	35-7/8
	mm	3386	3294	1759	1667	610	1219	224	502	1835	911

**DIMENSIONS – inches (mm)**  
**RMFH11 HORIZONTAL ROOF MOUNTING FRAME**

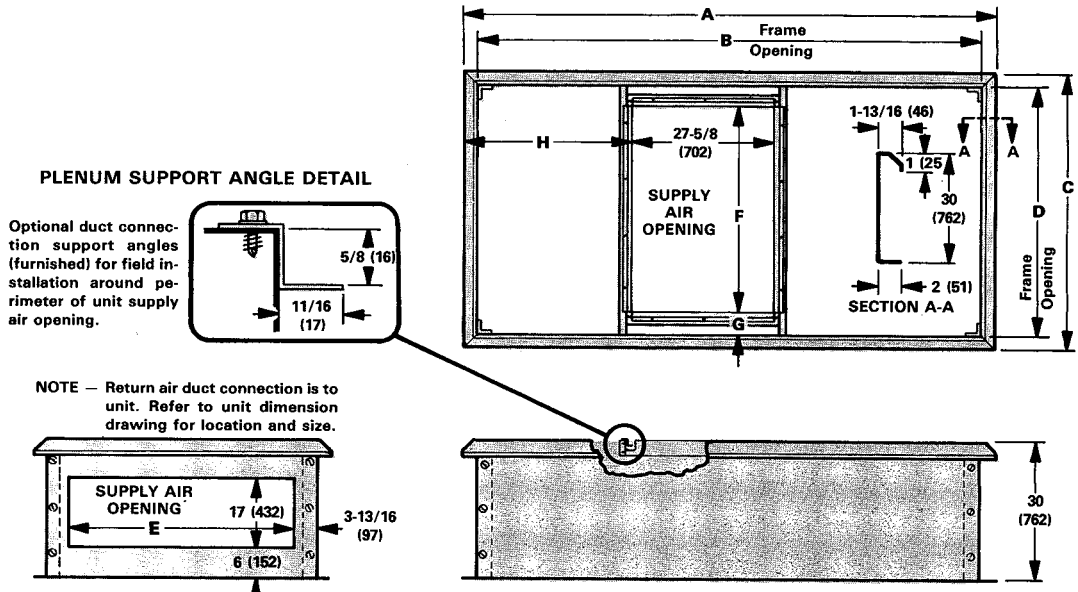

Model No.		A	B	C	D	E	F	G	H
RMFH11-185	in.	107-3/4	104-1/8	59-1/4	55-5/8	48	47-5/8	4	40-9/16
	mm	2737	2645	1505	1413	1219	1210	102	1030
RMFH11-275	in.	133-5/16	129-11/16	69-1/4	65-5/8	58	53-5/8	6	45-15/16
	mm	3386	3294	1759	1667	1473	1362	152	1167

**RMFA11 ADAPTER ROOF MOUNTING FRAME**

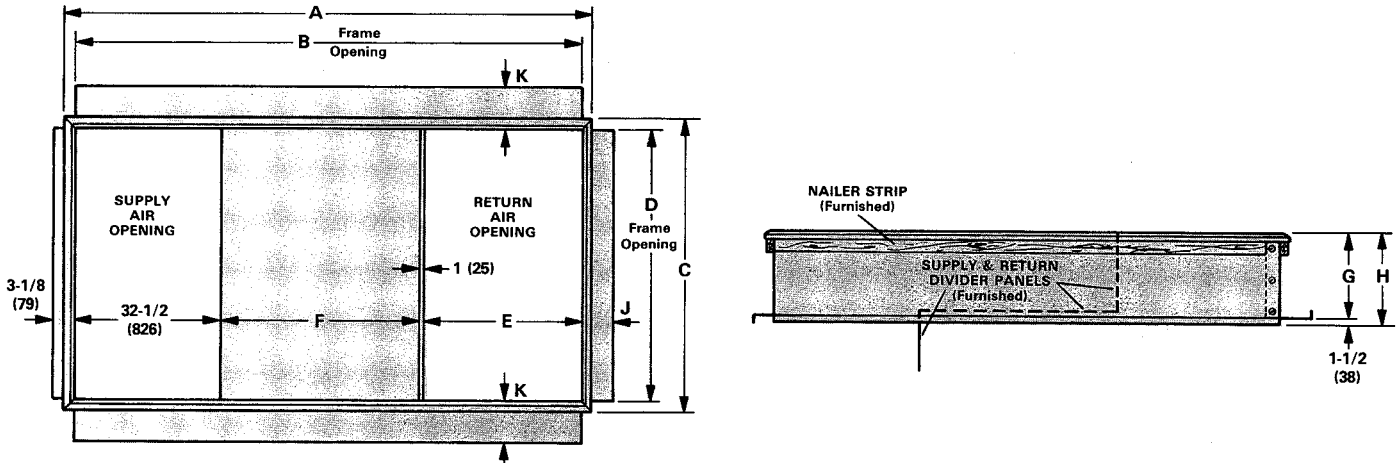

Model No.		A	B	C	D	E	F	G	H	J	K
RMFA11-185	in.	107-3/4	104-1/8	59-1/4	55-5/8	36	34-5/8	18	19-1/2	17/8	10-11/16
	mm	2737	2645	1505	1413	914	879	457	495	22	271
RMFA11-275	in.	124-1/16	120-7/16	69-1/4	65-5/8	42-3/8	44-9/16	22	23-1/2	----	5-11/16
	mm	3386	3059	1759	1667	1076	1132	559	597	----	144

RMFA11-185 requires filler panel (furnished) as shown below to match RMF3 frame length.

**TYPICAL FLASHING DETAIL FOR RMFA11 WITH RMF3 ROOF MOUNTING FRAME**

**RMFA11 ADAPTER ROOF MOUNTING FRAME WITH RMF3 ROOF MOUNTING FRAME**

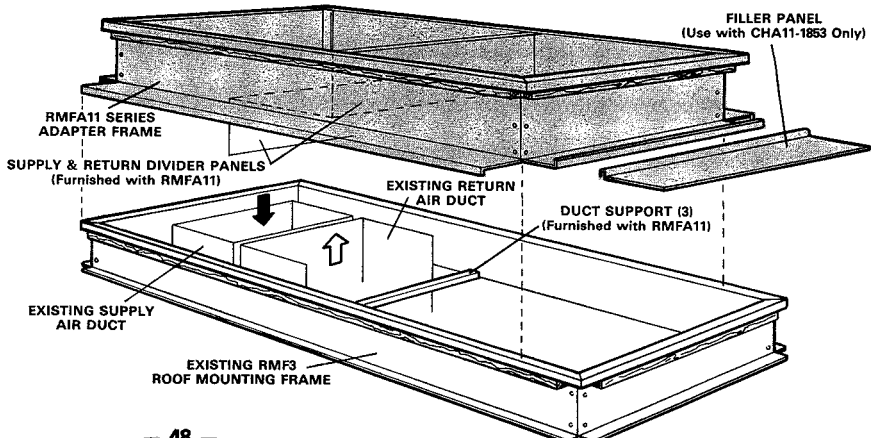
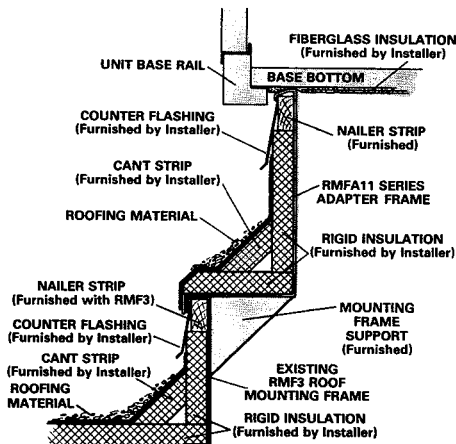

**COMBINATION CEILING SUPPLY AND RETURN AIR DIFFUSERS  
DIMENSIONS — inches (mm)**

**RTD11-185 & RTD11-275 STEP-DOWN CEILING DIFFUSER**

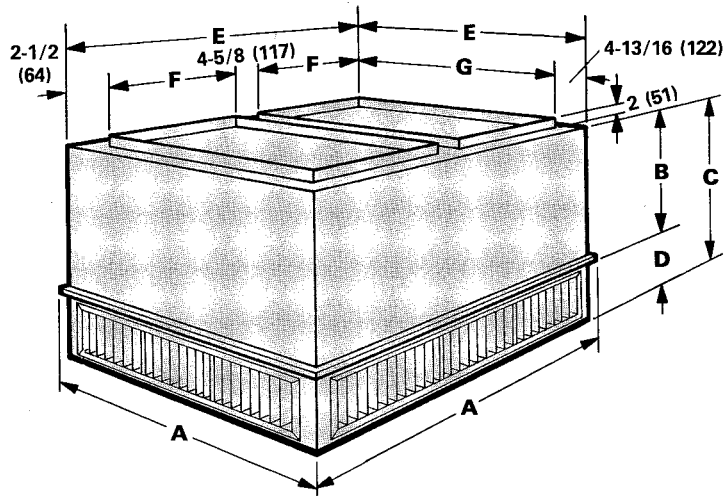

Model No.		A	B	C	D	E	F	G
RTD11-185	in.	47-5/8	23-7/8	34	10-1/8	45-5/8	18	36
	mm	1210	600	864	257	1159	457	914
RTD11-275	in.	59-5/8	28-7/8	40	11-1/8	57-5/8	24	48
	mm	1514	727	1016	283	1464	610	1219

**FD11-185 & FD11-275 FLUSH CEILING DIFFUSER**

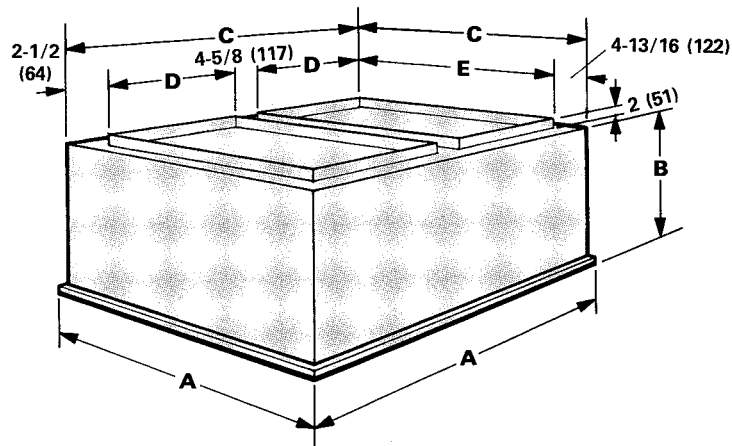

Model No.		A	B	C	D	E
FD11-185	in.	47-5/8	30-1/8	45-5/8	18	36
	mm	1210	765	1159	457	914
FD11-275	in.	59-5/8	36-1/8	57-5/8	24	48
	mm	1514	918	1464	610	1219

## GUIDE SPECIFICATIONS

**Prepared for the guidance of architects, consulting engineers and mechanical contractors.**

**General** — Furnish and install a single package combination air to air DX mechanical cooling system, complete with automatic controls. The single package unit shall be a standard product of a firm regularly engaged in the manufacture of heating-cooling equipment. The manufacturer shall have parts and service available throughout Canada.

The installed weight shall not be more than ..... lbs. (kg). Entire unit shall have a width of not more than ..... inches (mm), a depth of not more than ..... inches (mm) and an overall height of not more than ..... inches (mm). The equipment shall be shipped completely factory assembled, precharged, piped and wired internally ready for field connections. In addition, manufacturer shall test operate system at the factory before shipment.

**Air Distribution** — Equipment shall be capable of bottom or end (horizontal) handling of conditioned air. All air distribution ducts shall be fiberglass or ..... ga. galvanized steel insulated with ..... inch (mm) thick ..... lb./ft.<sup>3</sup> (kg/m<sup>3</sup>) density fiberglass or equivalent.

**Approvals** — Single package unit shall be listed by a certified agency. All wiring shall be in compliance with CEC.

**Equipment Warranty** — Compressors shall have a limited warranty for a full five years. All other components shall have a limited warranty for one year. Refer to the Lennox Equipment Limited Warranty certificate included with the unit for details.

**Cooling System** — The total certified cooling capacity shall not be less than ..... Btuh (kW) with an evaporator air volume of ..... cfm (L/s), an entering wet bulb air temperature of ..... °F (°C), an entering dry bulb air temperature of ..... °F (°C) and a condenser entering temperature of ..... °F (°C). The compressor power input shall not exceed ..... kW at these conditions.

The coils shall be non-ferrous construction with aluminum fins mechanically bonded to durable copper tubes. Coils shall be pressure leak tested. Coil face area shall be not less than ..... sq. ft. (m<sup>2</sup>) (evaporator) and ..... sq. ft. (m<sup>2</sup>) (condenser).

Dual compressors shall be resiliently mounted, have overload protection, internal pressure relief and crankcase heater. The refrigeration system shall have suction and liquid line service gauge ports, sight glasses, high pressure switches, loss of charge switches, driers and full refrigerant charge. Control option available shall consist of low ambient control. Shall be rated in accordance with ARI Standard 360-86.

**Additive Electric Heaters** — The certified total heating capacity output shall be ..... Btuh (kW) with ..... kW input at ..... volts power supply.

Optional electric heaters shall be available. Heating elements shall be nichrome bare wire exposed directly to the air stream. Time delays shall bring the elements on and off in sequence with a time delay between each element. Limit controls shall provide overload and short circuit protection.

**Cabinet** — Shall be galvanized steel with a paint finish of powdered enamel electrostatically bonded to the metal. Cabinet panels where conditioned air is handled shall be fully insulated to prevent sweating and minimize sound. Openings shall be provided for power connection entry. Base shall have drainage holes. Lifting lugs shall be provided for rigging.

**Service Access** — All components, wiring and inspection areas shall be completely accessible through removable panels.

**Supply Air Blowers** — Dual centrifugal supply air blower shall have permanently lubricated ball bearings and adjustable belt drive and motor mount where belt tension can be easily adjusted. The entire assembly shall be floated on resilient rubber mounts. Blower wheel shall be statically and dynamically balanced. Blower shall be capable of delivering ..... cfm (L/s) at an external static pressure of ..... inches water gauge (Pa) requiring ..... bhp (W) and ..... rpm.

**Condenser Fans** — Twin propeller type condenser fans shall discharge vertically and be direct driven by a ..... hp (W) motor. Fan motor shall be totally enclosed with sleeve bearings, permanently lubricated, inherently protected and equipped with rain shield. Fan shall have a safety guard.

**Air Filters** — 1" (25mm) thick disposable frame type fiberglass media filters shall have not less than ..... sq. ft. (m<sup>2</sup>) of free area.

### OPTIONAL ACCESSORIES

**Roof Mounting Frame** — Furnish and install a steel roof mounting frame for bottom or horizontal discharge and return air duct connection. It shall mate to the bottom perimeter of the equipment. When flashed into the roof it shall make a unit mounting curb and provide weatherproof duct connection and entry into the conditioned area. Flashing shall be the responsibility of a roofing contractor. Frame shall be approved by National Roofing Contractors Association.

**Economizer Dampers** — Furnish and install complete with controls an optional mechanically linked air mixing damper assembly including outdoor air and recirculated air dampers. The assembly shall mount within the confines of the unit cabinet and provide for the introduction of outside air for minimum ventilation and free cooling. Outdoor air hood shall mount external to the unit cabinet. Damper motor shall be 24 volt, fully modulating spring return. Controls shall include discharge air sensor, minimum position potentiometer and solid-state adjustable outdoor air enthalpy control. Control option shall consist of differential enthalpy control (return air sensor).

**Fresh Air Dampers** — Outdoor air damper section shall control outdoor air requirements and be available for manual or automatic operation. Dampers shall be adjustable for air quantities up to 25%. Shall include cleanable air filter.

**Gravity Exhaust Air Dampers** — Pressure operated dampers shall install within the unit. Damper blades shall ride in nylon bearings and be gasketed for tight seal and quiet operation.

**Power Exhaust Air Dampers** — Direct drive propeller type fans shall exhaust air through pressure relief dampers. Motors shall be overload protected. Pressure operated dampers shall install within the unit and prevent blow back and outdoor air infiltration during the fan off cycle. Damper blades shall ride in nylon bearings and be gasketed for tight seal and quiet operation.

**Ceiling Diffusers** — Furnish and install a (flush or stepdown) optional combination ceiling supply and return air diffuser. It shall be capable of not less than ..... ft. (m) radius of effective throw. Supply and return transitions shall be available, for field installation in the roof mounting frame, to provide duct connection to the diffuser.

**Remote Status Panel** — Shall be available for installation within the conditioned area to observe equipment operation. The panel shall include signal lights for Cool Mode, Heat Mode, Compressor 1, Compressor 2, No Heat and Filter.

**Remote Switching Status Panel** — Shall be available for installation within the conditioned area to control and observe equipment operation. The panel shall include signal lights for Cool Mode, Heat Mode, Compressor 1, Compressor 2, No Heat and Filter. System selector switch and fan switch shall provide operational mode and blower operation. After hours timer switch shall override night setback controls and provide normal operation for time period set.

**Control Systems** — Shall provide a selection of optional thermostats and related controls to automatically operate the mechanical equipment through the heating or cooling and ventilating cycles as required.