



AIR HANDLERS

CBX25UHV (-10)

MERIT® Series

R-410A - Upflow / Horizontal - Variable Speed

PRODUCT SPECIFICATIONS

Bulletin No. 210771
December 2018
Supersedes February 2017



Nominal Capacity - 1.5 to 5 Tons
Optional Electric Heat - 2.5 to 20 kW

MODEL NUMBER IDENTIFICATION

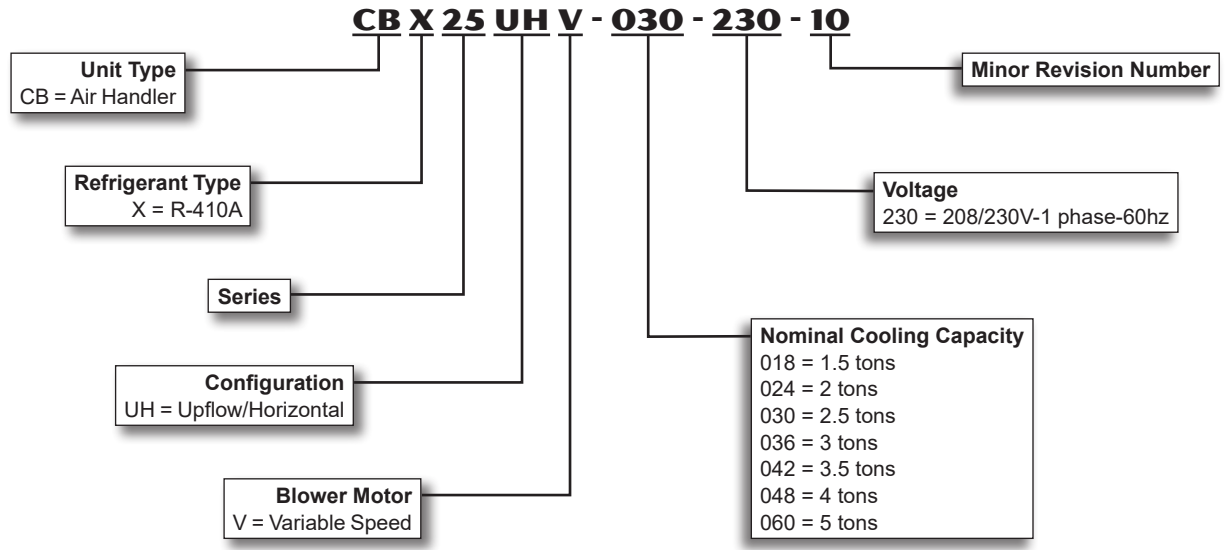

FEATURES

CONTENTS

Blower Data	6
Dimensions - Accessories	20
Dimensions - Unit	18
Electrical Data.....	5
Electric Heat Data.....	13
Features.....	2
Installation Clearances With Electric Heat.....	20
Model Number Identification	1
Optional Accessories	5
Replacement Circuit Breakers	17
Specifications.....	5

WARRANTY

All covered components - Limited five years in residential applications, one year in non-residential applications.

Refer to Lennox Limited Warranty Certificate included with each unit for additional details.

APPROVALS

Tested with matching air conditioners and heat pump units in the Lennox Research Laboratory environmental test room in accordance with AHRI Standard 210/240.

Optional electric heaters are rated in accordance with US Department of Energy (DOE) test procedures and Federal Trade Commission (FTC) labeling regulations.

Air handlers are ETL Listed to US and Canadian safety standards and components within are bonded for grounding to meet safety standards for servicing required by CEC and NEC.

ISO 9001 Registered Manufacturing Quality System.

APPLICATIONS

1.5 to 5 ton nominal sizes.

Upflow or horizontal applications.

Compact cabinet height for upflow, horizontal-left or horizontal-right applications.

NOTE - Not available for downflow applications.

Utility room, alcove, closet, crawl space, basement or attic installation.

CBX25UHV models are applicable to R-410A expansion valve systems in cooling applications and check and expansion valve systems in heat pump applications.

See bulletins in section Air Conditioners for cooling capacities.

See bulletins in section Heat Pump Outdoor Units for cooling and heating capacities.

Optional field installed electric heaters available in several sizes for additive heating capacity.

Zoning Applications

Units can be used with certain zoning systems.

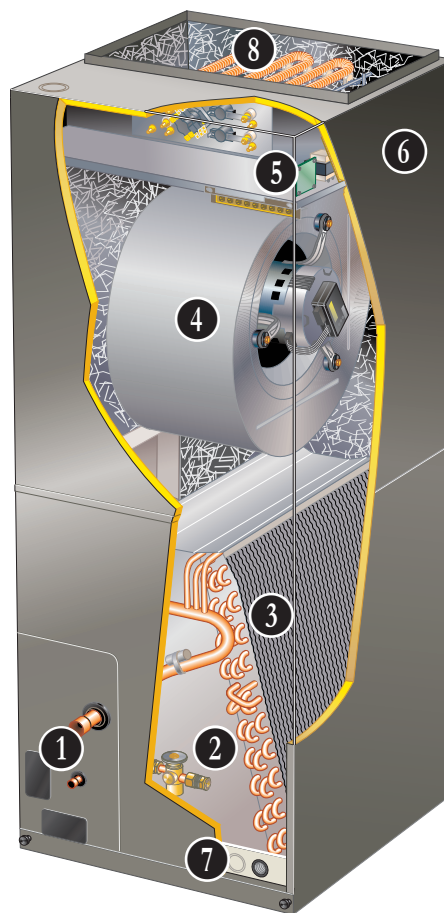

Zone control panel **MUST** be able to interface and communicate with the variable speed motor in the unit. Lennox Harmony III™ Zoning System has this capability.

REFRIGERANT SYSTEM

1 Refrigerant Line Connections

Suction (vapor) and liquid lines have sweat connections that extended outside of the cabinet for ease of connection.

See dimension drawing for locations.

2 Check and Expansion Valve Furnished

CBX25UHV models have non-chlorine, ozone friendly, R-410A valve.

Wide range valve.

Chatleff style fitting.

Factory installed on all models internal to cabinet.



3 Copper Tube/Enhanced Fin Evaporator Coil

Assembled in "A" configuration.

Provides extra large surface and contact area, excellent heat transfer and low air resistance for maximum efficiency.

Precise circuiting for uniform refrigerant distribution.

Precisely spaced ripple-edged aluminum fins fitted to durable seamless copper tubes.

Fins are strengthened to resist bending and are equipped with collars that grip tubing for maximum contact area.

FEATURES

REFRIGERANT SYSTEM (continued)

Lanced fins provide maximum exposure of fin surface to air stream.

Long life copper tubing is easy to service.

Rifled tubing provides superior heat transfer.

Flared shoulder tubing joints and silver soldering provide tight, leakproof joints.

Coil thoroughly factory tested under high pressure to insure leakproof construction.

4 BLOWER

Programmable Multi-Speed Blower Motor

High efficiency multi-speed blower motor maintains specified air volumes up to a maximum of 0.8 in. w.g. total external static.

Programmable multi-speed operation is achieved by the use of an ECM (Electronically Commutated Motor) motor.

Allows cooling ramping profiles (field selectable) for enhanced dehumidification.

Motor accelerates and decelerates gradually, reducing start-up and shut-down sound.

Leadless blower motor features simple plug-in connections.

Motor is controlled by BDC3 Electronic Blower Control that allows blower to operate at two of eight air volumes or speeds available.

Blower speeds may be field selected on blower control depending on size of air handler and air volume desired.

See Blower Data tables.

Blower Assembly

Each blower is statically and dynamically balanced as an assembly before installation in the unit.

Blower motor is resiliently mounted to blower assembly.

Blower slides out of cabinet for servicing.



CONTROLS

BDC3 Electronic Blower Control

Controls evaporator humidity by controlling blower and compressor staging on two-stage outdoor units.

Two Stages - HEAT and COOL (with four different air volume selections for each) are made by simple jumper pins on board.

ADJUST jumper pin allows approximately 10% higher, normal or 10% lower motor speed selection within HEAT and COOL speeds selected for fine tuning air volume.

DELAY jumper pin allows selection of four different blower motor de-humidification profiles during cooling mode:

Option 1 - Motor runs at 100% of capacity until demand met. Once demand is met, motor ramps down to stop.

Option 2 - Motor runs at 100% until demand is met. Once demand is satisfied, motor runs at 100% for 60 seconds then ramps down to stop.

Option 3 - Motor runs at 82% of capacity for approximately 7-1/2 minutes, then 100% capacity (if needed) until demand is satisfied. Once demand is met, motor ramps down to stop.

Option 4 - Motor runs at 50% capacity for 30 seconds, then 82% capacity for approximately 7-1/2 minutes. If demand is not satisfied, motor runs at 100% capacity until demand is met. Once demand is met, motor runs at 50% capacity for 30 seconds, then ramps down to stop. Control has two diagnostic indicator lights, "CFM" and "RUN", to assist in servicing.

Accessory relay terminals (24V) provide connections for power humidifiers or powered air cleaners.

Control is factory installed in the unit control box.

5 Transformer and Blower Relay for Electric Heat
24 volt transformer and blower relay for electric heat furnished as standard.

Factory installed in the unit control box.

Optional Accessories

Thermostat

See Thermostat bulletins in Controls section and Lennox Price Book for a complete list of thermostats.

6 CABINET

Constructed of heavy gauge galvanized steel.

Powder paint finish.

Completely insulated with foil faced fiberglass insulation.

Removable panels provide complete service access.

Filter access door for easy filter replacement.

Thumbscrews secure filter door.

Electrical inlets provided in sides and top of cabinet.

See dimension drawing for locations.

Plugs in cabinet for drain connections for upflow (left and right) and horizontal applications. See dimension drawing.

Low Leakage Cabinet

All models have less than 2% air leakage and meet ANSI/ASHRAE Standard 193-2010 "Method of Test for Determining the Air Tightness of HVAC Equipment."

Upflow/Horizontal Capability

Shipped for upflow and horizontal left-hand discharge.

May be field converted to horizontal right-hand air discharge by repositioning horizontal drain pan.

NOTE - Not available for downflow applications.

FEATURES

CABINET (continued)

7 Anti-Microbial Dual Position Drain Pans

Anti-Microbial additive resists growth of mold and mildew on drain pan which improves indoor air quality and reduces drain line blockage.



Drain pans designed for upflow or horizontal applications.

Deep, corrosion resistant high temperature engineered polymer drain pans have dual pipe drains.

See dimension drawing.

Optional Accessories

Horizontal Support Frame Kit

Provides support of unit in horizontal applications.

Consists of (2) 1 x 1-1/2 x 32-5/8 in. and (2) 1 x 3 x 53-7/8 in. painted heavy gauge cold rolled steel support channels with assembly and suspending holes.

Bolts and nuts furnished for field assembly.

Suspending rods must be field provided.

Side Return Unit Stand (Upflow Only)

Raises unit 16 in. above floor for side return air duct connection.

Eliminates need for wooden platform construction.

All aluminum construction.

Two adjustable frames fit all sizes.

See Dimension Drawing.

Wall Hanging Bracket Kit (Upflow Only)

Allows unit to be hung on wall at any height.

Consists of heavy gauge steel support brackets (one for air handler unit, one for wall mount).

Screws furnished for fastening one bracket to unit.

Bolts for fastening one bracket to wall are field provided.

High Performance Economizer (Commercial Applications Only)

Designed for applications requiring outdoor air to be utilized in a commercial HVAC system. Allows the entry of fresh outdoor air for free cooling, reducing the requirement for mechanical cooling.

Heavy gauge galvanized steel cabinet lined with thick fiberglass insulation.

Mixed air sensor, outdoor air sensor and 24VAC transformer furnished.

Approved for California Title 24 building standards.

ASHRAE 90.1-2010 compliant.

See separate Product Specifications bulletin for additional information and available control and sensor options.

FILTER

Disposable 1 inch filter is furnished.

Filter rack furnished in cabinet for easy filter installation.

See Specifications tables for filter sizes.

ELECTRICAL

Optional Accessories

8 Electric Heat

Field install internal to unit cabinet.

Available in several kW sizes.

See Electric Heat tables.

Helix wound nichrome heating elements exposed directly in air stream resulting in instant heat transfer, low element temperatures and long service life.

Each element equipped with accurately located limit control with fixed temperature off setting and automatic reset.

Thermal sequencer relay brings elements on and off line, in sequence and equal increments, with time delay between each.

Initiates and terminates blower operation.

Heating control relay(s) furnished as standard.

Factory assembled with controls installed and wired.

Electric heat control wiring plugs into mating connector on air handler unit.

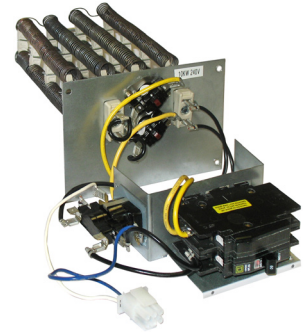

Circuit Breaker Models

ECB25-5CB, ECB25-7.5CB, ECB25-10CB, ECB25-12.5, ECB25-15CB, ECB25-20CB heaters are equipped with circuit breakers for overload and short circuit protection.

Factory wired and mounted on electric heat unit.

Current sensitive and temperature actuated.

Manual reset.

Flexible plastic circuit breaker cover protects circuit breaker in areas with high humidity or unconditioned areas to prevent nuisance tripping.

Circuit breakers qualify as disconnect means at unit in many areas, eliminate the need for field provided disconnect.

Consult local electrical code in your area.

Single-point Power Source Control Box

Control Box may be used with optional electric heat when single power supply is connected to multi-circuit electric heat.

Field installs external to the unit cabinet on either side or top.

Constructed of heavy gauge steel, baked enamel finish, prepunched mounting holes, electrical inlet knockouts, and terminal strip.

Removable cover provides easy access.

Dimensions (H x W x D) - 7 x 7 x 4 in.

SPECIFICATIONS

General Data		Model Number	CBX25UHV-018	CBX25UHV-024	CBX25UHV-030	CBX25UHV-036
		Nominal tonnage	1.5	2	2.5	3
Connections	Suction/Vapor line (o.d.) - in. sweat		3/4	3/4	7/8	7/8
	Liquid line (o.d.) - in. sweat		3/8	3/8	3/8	3/8
	Condensate - in. fpt		(2) 3/4	(2) 3/4	(2) 3/4	(2) 3/4
Indoor Coil	Net face area - ft. ²		3.11	3.56	4.00	4.89
	Tube outside diameter - in.		3/8	3/8	3/8	3/8
	Number of rows		3	3	3	3
	Fins per inch		14	14	14	14
Blower	Wheel nominal diameter x width - in.		9 x 6	9 x 6	10 x 8	10 x 8
	Blower motor output - hp		1/2	1/2	1/2	1/2
¹ Filters	Size of filter - in.		12 x 20 x 1	15 x 20 x 1	15 x 20 x 1	18 x 20 x 1

ELECTRICAL DATA

		Voltage - 1 phase (60 hz)	208/240V	208/240V	208/240V	208/240V
		² Maximum overcurrent protection (unit only)	15	15	15	15
		³ Minimum circuit ampacity (unit only)	4.9	4.9	4.9	4.9
		Blower Motor Full Load Amps	3.9	3.9	3.9	3.9
Shipping Data -1 package - lbs.			105	123	126	161

SPECIFICATIONS

General Data		Model Number	CBX25UHV-042	CBX25UHV-048	CBX25UHV-060
		Nominal tonnage	3.5	4	5
Connections	Suction/Vapor line (o.d.) - in. sweat		7/8	7/8	7/8
	Liquid line (o.d.) - in. sweat		3/8	3/8	3/8
	Condensate - in. fpt		(2) 3/4	(2) 3/4	(2) 3/4
Indoor Coil	Net face area - ft. ²		5.83	7.00	7.00
	Tube outside diameter - in.		3/8	3/8	3/8
	Number of rows		3	3	3
	Fins per inch		14	14	14
Blower	Wheel nominal diameter x width - in.		12 x 8	12 x 9	12 x 9
	Blower motor output - hp		3/4	1	1
¹ Filters	Size of filter - in.		18 x 24 x 1	18 x 24 x 1	18 x 24 x 1

ELECTRICAL DATA

		Voltage - 1 phase (60 hz)	208/240V	208/240V	208/240V
		² Maximum overcurrent protection (unit only)	15	15	15
		³ Minimum circuit ampacity (unit only)	6.5	8.6	8.6
		Blower Motor Full Load Amps	5.2	6.9	6.9
Shipping Data -1 package - lbs.			163	186	186

¹ Disposable filter.

² HACR type circuit breaker or fuse.

³ Refer to National or Canadian Electrical Code manual to determine wire, fuse and disconnect size requirements. Use wires suitable for at least 167°F.

OPTIONAL ACCESSORIES - ORDER SEPARATELY

Model	-018	-024 -030	-036	-042 -048 -060
Horizontal Support Frame Kit	56J18	56J18	56J18	56J18
Side Return Unit Stand (Upflow Only)	45K31	45K32	45K32	45K32
Single-Point Power Source Control Box (for Electric Heat)	21H39	21H39	21H39	21H39
Wall Hanging Bracket Kit (Upflow Only)	45K30	45K30	45K30	45K30
High Performance Economizer (Commercial Only)	10U53	10U53	10U53	10U53

BLOWER DATA

CBX25UHV-018 BLOWER PERFORMANCE

0 through 0.80 in. w.g. External Static Pressure Range

"ADJUST" Jumper Setting	Jumper Speed Positions											
	"HEAT" Speed				First Stage "COOL" Speed				Second Stage "COOL" Speed			
	1	2	3	4	1	2	3	4	1	2	3	4
	cfm	cfm	cfm	cfm	cfm	cfm	cfm	cfm	cfm	cfm	cfm	cfm
+	470	670	890	1080	350	470	620	760	470	675	890	1090
NORM	440	615	810	1000	350	450	560	700	435	610	815	1020
-	400	560	730	910	350	420	520	650	400	575	725	915

NOTES - The effect of static pressure, filter and electric heater resistance is included in the air volumes listed.

First stage cooling air volume is 70% of COOL speed setting. Continuous blower speed is approximately 50% of COOL speed setting.

Lennox Harmony III™ Zoning System applications - minimum blower speed is 250 cfm.

CBX25UHV-018 BLOWER MOTOR WATTS

AT "+" (Plus) SETTING ("Adjust" Jumper at "+" Setting)

Jumper Speed Positions		Motor Watts @ Various External Static Pressures - in. wg.							
		0.1	0.2	0.3	0.4	0.5	0.6	0.7	0.8
"HEAT" Speed	Tap 1	49	61	83	98	118	128	140	151
	Tap 2	109	126	136	152	176	192	213	240
	Tap 3	223	239	261	290	311	331	347	366
	Tap 4	418	449	471	482	481	486	481	477
First Stage "COOL" Speed	Tap 1	25	40	55	69	77	94	109	126
	Tap 2	50	65	74	91	115	128	138	157
	Tap 3	93	107	128	142	155	176	189	226
	Tap 4	155	171	192	206	227	246	266	281
Second Stage "COOL" Speed	Tap 1	48	67	78	96	113	129	137	149
	Tap 2	105	125	140	154	174	194	211	233
	Tap 3	220	242	265	286	301	324	349	368
	Tap 4	414	445	473	489	491	489	480	485

AT "NORM" SETTING ("Adjust" Jumper at NORM Setting)

Jumper Speed Positions		Motor Watts @ Various External Static Pressures - in. wg.							
		0.1	0.2	0.3	0.4	0.5	0.6	0.7	0.8
"HEAT" Speed	Tap 1	44	60	69	94	104	117	123	139
	Tap 2	86	102	118	129	152	165	204	218
	Tap 3	170	187	208	233	247	270	284	302
	Tap 4	311	332	357	377	407	437	452	474
First Stage "COOL" Speed	Tap 1	25	40	56	68	77	94	110	125
	Tap 2	40	55	68	81	107	118	133	143
	Tap 3	71	89	101	120	130	169	180	195
	Tap 4	124	142	159	175	191	213	234	240
Second Stage "COOL" Speed	Tap 1	36	52	67	86	100	114	122	140
	Tap 2	83	97	117	133	149	165	193	214
	Tap 3	169	188	213	227	250	267	287	308
	Tap 4	311	332	367	384	409	430	447	465

AT "-" (Minus) SETTING ("Adjust" Jumper at "-" Setting)

Jumper Speed Positions		Motor Watts @ Various External Static Pressures - in. wg.							
		0.1	0.2	0.3	0.4	0.5	0.6	0.7	0.8
"HEAT" Speed	Tap 1	34	43	60	83	93	101	117	135
	Tap 2	69	85	98	113	130	157	173	188
	Tap 3	130	149	162	187	201	222	240	253
	Tap 4	231	253	278	289	319	326	352	384
First Stage "COOL" Speed	Tap 1	25	40	59	64	72	90	113	120
	Tap 2	30	45	63	82	94	99	122	134
	Tap 3	60	74	86	96	116	146	156	170
	Tap 4	99	120	128	143	166	188	201	240
Second Stage "COOL" Speed	Tap 1	31	42	58	77	92	98	109	128
	Tap 2	66	84	99	111	131	157	175	180
	Tap 3	128	150	166	186	200	222	240	255
	Tap 4	233	255	286	303	320	344	372	386

BLOWER DATA

CBX25UHV-024 BLOWER PERFORMANCE

0 through 0.80 in. w.g. External Static Pressure Range

"ADJUST" Jumper Setting	Jumper Speed Positions											
	"HEAT" Speed				First Stage "COOL" Speed				Second Stage "COOL" Speed			
	1	2	3	4	1	2	3	4	1	2	3	4
	cfm	cfm	cfm	cfm	cfm	cfm	cfm	cfm	cfm	cfm	cfm	cfm
+	470	690	900	1120	350	470	625	775	480	670	890	1125
NORM	430	640	810	1020	330	450	580	720	430	605	820	1020
-	410	550	720	900	300	405	505	650	390	545	740	930

NOTES - The effect of static pressure, filter and electric heater resistance is included in the air volumes listed.

First stage cooling air volume is 70% of COOL speed setting. Continuous blower speed is approximately 50% of COOL speed setting.

Lennox Harmony III™ Zoning System applications - minimum blower speed is 250 cfm.

CBX25UHV-024 BLOWER MOTOR WATTS

AT "+" (Plus) SETTING ("Adjust" Jumper at "+" Setting)

Jumper Speed Positions		Motor Watts @ Various External Static Pressures - in. wg.							
		0.1	0.2	0.3	0.4	0.5	0.6	0.7	0.8
"HEAT" Speed	Tap 1	49	64	79	94	109	125	141	157
	Tap 2	66	88	109	131	146	170	188	217
	Tap 3	145	172	188	217	239	266	289	314
	Tap 4	271	299	332	362	377	405	421	456
First Stage "COOL" Speed	Tap 1	15	23	37	52	72	92	101	117
	Tap 2	27	52	62	87	113	130	144	159
	Tap 3	66	82	101	123	138	158	185	217
	Tap 4	105	123	148	170	187	211	232	262
Second Stage "COOL" Speed	Tap 1	45	62	75	90	104	118	137	153
	Tap 2	64	86	111	129	148	168	198	228
	Tap 3	146	174	195	217	242	263	291	316
	Tap 4	274	289	325	362	367	407	434	466

AT "NORM" SETTING ("Adjust" Jumper at NORM Setting)

Jumper Speed Positions		Motor Watts @ Various External Static Pressures - in. wg.							
		0.1	0.2	0.3	0.4	0.5	0.6	0.7	0.8
"HEAT" Speed	Tap 1	30	43	59	76	96	112	124	145
	Tap 2	52	75	88	111	131	151	181	209
	Tap 3	111	135	157	177	198	224	250	264
	Tap 4	204	231	259	278	308	324	356	381
First Stage "COOL" Speed	Tap 1	12	20	30	45	64	84	110	119
	Tap 2	25	46	60	81	99	113	136	150
	Tap 3	45	59	85	96	115	144	170	189
	Tap 4	75	97	122	144	161	183	206	226
Second Stage "COOL" Speed	Tap 1	31	44	60	77	94	111	120	139
	Tap 2	50	74	92	108	129	151	174	206
	Tap 3	115	134	159	180	206	228	249	267
	Tap 4	210	232	267	284	309	335	364	384

AT "-" (Minus) SETTING ("Adjust" Jumper at "-" Setting)

Jumper Speed Positions		Motor Watts @ Various External Static Pressures - in. wg.							
		0.1	0.2	0.3	0.4	0.5	0.6	0.7	0.8
"HEAT" Speed	Tap 1	22	30	45	62	84	106	117	130
	Tap 2	44	57	80	98	114	139	173	183
	Tap 3	87	108	122	149	170	181	207	228
	Tap 4	153	180	202	232	239	275	301	320
First Stage "COOL" Speed	Tap 1	8	15	26	41	59	74	98	112
	Tap 2	23	44	59	75	91	104	122	140
	Tap 3	29	48	69	89	119	128	142	178
	Tap 4	58	77	97	118	136	155	180	216
Second Stage "COOL" Speed	Tap 1	22	30	45	61	83	96	116	128
	Tap 2	41	58	80	99	114	146	170	189
	Tap 3	81	103	125	150	170	188	209	232
	Tap 4	150	176	201	222	245	272	291	320

BLOWER DATA

CBX25UHV-030 BLOWER PERFORMANCE

0 through 0.80 in. w.g. External Static Pressure Range

"ADJUST" Jumper Setting	Jumper Speed Positions											
	"HEAT" Speed				First Stage "COOL" Speed				Second Stage "COOL" Speed			
	1	2	3	4	1	2	3	4	1	2	3	4
	cfm	cfm	cfm	cfm	cfm	cfm	cfm	cfm	cfm	cfm	cfm	cfm
+	650	900	1100	1320	430	600	740	920	650	875	1100	1330
NORM	590	795	1000	1200	390	550	680	830	580	800	1000	1200
-	520	730	895	1075	340	475	620	750	500	700	900	1090

NOTES - The effect of static pressure, filter and electric heater resistance is included in the air volumes listed.

First stage cooling air volume is 70% of COOL speed setting. Continuous blower speed is approximately 50% of COOL speed setting.

Lennox Harmony III™ Zoning System applications - minimum blower speed is 250 cfm.

CBX25UHV-030 BLOWER MOTOR WATTS

AT "+" (Plus) SETTING ("Adjust" Jumper at "+" Setting)

Jumper Speed Positions		Motor Watts @ Various External Static Pressures - in. wg.							
		0.1	0.2	0.3	0.4	0.5	0.6	0.7	0.8
"HEAT" Speed	Tap 1	45	75	97	116	139	156	180	197
	Tap 2	113	137	164	189	210	232	258	285
	Tap 3	198	228	261	275	313	348	373	409
	Tap 4	321	358	387	417	456	493	523	513
First Stage "COOL" Speed	Tap 1	23	43	63	73	87	107	129	143
	Tap 2	39	65	105	110	126	144	155	169
	Tap 3	73	101	126	144	160	192	213	232
	Tap 4	117	140	170	197	219	245	268	297
Second Stage "COOL" Speed	Tap 1	42	75	97	119	139	153	173	189
	Tap 2	113	138	161	187	206	230	255	291
	Tap 3	197	216	241	283	309	343	371	397
	Tap 4	323	350	386	421	458	476	519	510

AT "NORM" SETTING ("Adjust" Jumper at NORM Setting)

Jumper Speed Positions		Motor Watts @ Various External Static Pressures - in. wg.							
		0.1	0.2	0.3	0.4	0.5	0.6	0.7	0.8
"HEAT" Speed	Tap 1	33	58	85	109	123	141	158	173
	Tap 2	86	109	141	161	175	198	228	258
	Tap 3	150	180	210	240	267	294	312	341
	Tap 4	252	274	294	333	375	398	432	467
First Stage "COOL" Speed	Tap 1	18	30	44	64	86	104	116	139
	Tap 2	29	56	71	90	110	125	139	157
	Tap 3	55	84	106	124	147	173	188	206
	Tap 4	95	122	144	172	191	214	246	270
Second Stage "COOL" Speed	Tap 1	37	55	79	98	120	141	155	171
	Tap 2	85	107	134	155	176	198	228	251
	Tap 3	151	170	201	229	255	279	311	340
	Tap 4	249	276	304	338	371	405	442	465

AT "-" (Minus) SETTING ("Adjust" Jumper at "-" Setting)

Jumper Speed Positions		Motor Watts @ Various External Static Pressures - in. wg.							
		0.1	0.2	0.3	0.4	0.5	0.6	0.7	0.8
"HEAT" Speed	Tap 1	27	52	70	92	110	124	135	157
	Tap 2	68	93	111	129	152	182	199	215
	Tap 3	113	139	168	179	205	238	261	299
	Tap 4	185	207	231	273	290	321	347	382
First Stage "COOL" Speed	Tap 1	15	26	40	59	78	99	109	127
	Tap 2	23	42	63	82	92	110	130	150
	Tap 3	45	68	91	110	134	154	165	178
	Tap 4	71	104	121	144	163	190	220	237
Second Stage "COOL" Speed	Tap 1	26	49	64	83	108	125	134	149
	Tap 2	60	88	116	131	151	182	197	208
	Tap 3	115	135	162	192	212	240	268	287
	Tap 4	186	211	236	268	304	328	346	380

BLOWER DATA

CBX25UHV-036 BLOWER PERFORMANCE

0 through 0.80 in. w.g. External Static Pressure Range

"ADJUST" Jumper Setting	Jumper Speed Positions											
	"HEAT" Speed				First Stage "COOL" Speed				Second Stage "COOL" Speed			
	1	2	3	4	1	2	3	4	1	2	3	4
	cfm	cfm	cfm	cfm	cfm	cfm	cfm	cfm	cfm	cfm	cfm	cfm
+	880	1115	1345	1435	615	770	930	1090	880	1110	1340	1435
NORM	800	1010	1215	1425	555	695	845	990	795	1005	1215	1420
-	715	905	1095	1275	505	625	755	885	715	905	1090	1280

NOTES - The effect of static pressure, filter and electric heater resistance is included in the air volumes listed.

First stage cooling air volume is 70% of COOL speed setting. Continuous blower speed is approximately 50% of COOL speed setting.

Lennox Harmony III™ Zoning System applications - minimum blower speed is 250 cfm.

CBX25UHV-036 BLOWER MOTOR WATTS

AT "+" (Plus) SETTING ("Adjust" Jumper at "+" Setting)

Jumper Speed Positions		Motor Watts @ Various External Static Pressures - in. wg.							
		0.1	0.2	0.3	0.4	0.5	0.6	0.7	0.8
"HEAT" Speed	Tap 1	111	130	151	175	198	218	241	263
	Tap 2	190	215	242	272	297	327	354	379
	Tap 3	310	339	374	409	442	474	505	512
	Tap 4	491	520	512	511	515	518	515	512
First Stage "COOL" Speed	Tap 1	55	71	88	107	124	140	156	171
	Tap 2	84	101	120	143	162	182	202	220
	Tap 3	124	145	167	193	215	237	259	283
	Tap 4	180	204	231	258	283	310	338	363
Second Stage "COOL" Speed	Tap 1	110	130	151	176	198	218	240	262
	Tap 2	190	213	240	269	297	324	351	374
	Tap 3	311	339	373	407	440	472	503	512
	Tap 4	487	521	514	513	516	519	517	514

AT "NORM" SETTING ("Adjust" Jumper at NORM Setting)

Jumper Speed Positions		Motor Watts @ Various External Static Pressures - in. wg.							
		0.1	0.2	0.3	0.4	0.5	0.6	0.7	0.8
"HEAT" Speed	Tap 1	90	108	127	151	170	192	211	229
	Tap 2	151	171	195	223	247	271	294	318
	Tap 3	236	264	294	327	356	384	415	445
	Tap 4	370	400	436	473	509	518	515	512
First Stage "COOL" Speed	Tap 1	46	61	78	95	112	126	140	155
	Tap 2	71	85	104	124	143	161	178	196
	Tap 3	101	119	140	163	185	206	227	247
	Tap 4	141	162	187	213	239	258	280	309
Second Stage "COOL" Speed	Tap 1	91	108	128	151	171	191	212	230
	Tap 2	148	171	196	223	247	273	297	318
	Tap 3	241	265	295	327	356	384	413	443
	Tap 4	369	396	432	472	508	519	516	513

AT "-" (Minus) SETTING ("Adjust" Jumper at "-" Setting)

Jumper Speed Positions		Motor Watts @ Various External Static Pressures - in. wg.							
		0.1	0.2	0.3	0.4	0.5	0.6	0.7	0.8
"HEAT" Speed	Tap 1	73	89	108	128	148	165	184	202
	Tap 2	116	136	159	184	207	228	251	272
	Tap 3	184	206	232	261	288	315	340	366
	Tap 4	274	298	332	366	397	427	457	484
First Stage "COOL" Speed	Tap 1	40	54	69	86	101	115	128	142
	Tap 2	57	72	90	109	126	143	159	174
	Tap 3	81	98	117	139	158	177	196	215
	Tap 4	111	131	152	177	200	220	242	264
Second Stage "COOL" Speed	Tap 1	73	89	109	129	149	167	184	203
	Tap 2	118	137	159	183	208	228	250	272
	Tap 3	181	203	230	259	284	311	339	363
	Tap 4	272	298	332	366	397	428	458	490

BLOWER DATA

CBX25UHV-042 BLOWER PERFORMANCE

0 through 0.80 in. w.g. External Static Pressure Range

"ADJUST" Jumper Setting	Jumper Speed Positions											
	"HEAT" Speed				First Stage "COOL" Speed				Second Stage "COOL" Speed			
	1	2	3	4	1	2	3	4	1	2	3	4
	cfm	cfm	cfm	cfm	cfm	cfm	cfm	cfm	cfm	cfm	cfm	cfm
+	1115	1345	1560	1800	800	960	1120	1265	1130	1370	1580	1800
NORM	1025	1215	1415	1630	730	870	1020	1150	1040	1240	1450	1640
-	925	1110	1280	1460	650	790	915	1050	950	1120	1290	1470

NOTES - The effect of static pressure, filter and electric heater resistance is included in the air volumes listed.

First stage cooling air volume is 70% of COOL speed setting. Continuous blower speed is approximately 50% of COOL speed setting.

Lennox Harmony III™ Zoning System applications - minimum blower speed is 450 cfm.

CBX25UHV-042 BLOWER MOTOR WATTS

AT "+" (Plus) SETTING ("Adjust" Jumper at "+" Setting)

Jumper Speed Positions		Motor Watts @ Various External Static Pressures - in. wg.							
		0.1	0.2	0.3	0.4	0.5	0.6	0.7	0.8
"HEAT" Speed	Tap 1	107	125	152	179	197	231	251	277
	Tap 2	153	185	216	238	264	300	325	353
	Tap 3	234	270	313	334	372	406	431	472
	Tap 4	343	379	414	449	492	536	579	611
First Stage "COOL" Speed	Tap 1	50	66	83	100	127	146	164	185
	Tap 2	73	92	113	136	155	175	207	221
	Tap 3	98	121	148	172	196	214	240	268
	Tap 4	133	161	190	217	242	268	295	325
Second Stage "COOL" Speed	Tap 1	108	132	162	181	203	227	254	280
	Tap 2	159	181	219	243	273	303	336	364
	Tap 3	234	267	303	333	367	410	440	477
	Tap 4	354	392	431	463	503	544	586	623

AT "NORM" SETTING ("Adjust" Jumper at NORM Setting)

Jumper Speed Positions		Motor Watts @ Various External Static Pressures - in. wg.							
		0.1	0.2	0.3	0.4	0.5	0.6	0.7	0.8
"HEAT" Speed	Tap 1	86	107	132	149	171	196	220	246
	Tap 2	119	146	174	201	219	255	276	307
	Tap 3	181	208	240	271	298	336	369	392
	Tap 4	271	305	339	376	402	440	473	516
First Stage "COOL" Speed	Tap 1	44	56	76	90	112	132	150	172
	Tap 2	56	77	96	110	136	161	186	209
	Tap 3	82	110	131	151	175	192	222	244
	Tap 4	106	134	155	188	205	233	261	279
Second Stage "COOL" Speed	Tap 1	85	106	132	153	177	197	219	245
	Tap 2	128	151	180	202	232	261	279	308
	Tap 3	184	211	247	273	307	331	365	397
	Tap 4	264	297	337	372	403	439	483	503

AT "-" (Minus) SETTING ("Adjust" Jumper at "-" Setting)

Jumper Speed Positions		Motor Watts @ Various External Static Pressures - in. wg.							
		0.1	0.2	0.3	0.4	0.5	0.6	0.7	0.8
"HEAT" Speed	Tap 1	73	88	109	134	145	175	199	217
	Tap 2	98	125	148	176	198	220	239	268
	Tap 3	138	167	195	218	247	275	306	324
	Tap 4	198	223	262	297	328	364	376	422
First Stage "COOL" Speed	Tap 1	39	45	63	88	104	126	142	156
	Tap 2	49	66	84	102	123	147	161	189
	Tap 3	68	91	112	125	146	174	195	217
	Tap 4	86	111	131	153	177	197	223	248
Second Stage "COOL" Speed	Tap 1	64	87	108	132	155	171	195	221
	Tap 2	105	127	154	177	201	225	250	270
	Tap 3	138	166	195	220	253	275	306	336
	Tap 4	197	229	263	291	316	362	389	419

BLOWER DATA

CBX25UHV-048 BLOWER PERFORMANCE

0 through 0.80 in. w.g. External Static Pressure Range

"ADJUST" Jumper Setting	Jumper Speed Positions											
	"HEAT" Speed				First Stage "COOL" Speed				Second Stage "COOL" Speed			
	1	2	3	4	1	2	3	4	1	2	3	4
	cfm	cfm	cfm	cfm	cfm	cfm	cfm	cfm	cfm	cfm	cfm	cfm
+	1450	1670	1880	2340	1050	1200	1340	1650	1440	1670	1950	2340
NORM	1340	1520	1730	2100	950	1100	1230	1520	1325	1530	1740	2150
-	1210	1390	1570	1915	850	1000	1110	1375	1200	1380	1600	1950

NOTES - The effect of static pressure, filter and electric heater resistance is included in the air volumes listed.

First stage cooling air volume is 70% of COOL speed setting. Continuous blower speed is approximately 50% of COOL speed setting.

Lennox Harmony III™ Zoning System applications - minimum blower speed is 450 cfm.

CBX25UHV-048 BLOWER MOTOR WATTS

AT "+" (Plus) SETTING ("Adjust" Jumper at "+" Setting)

Jumper Speed Positions		Motor Watts @ Various External Static Pressures - in. wg.							
		0.1	0.2	0.3	0.4	0.5	0.6	0.7	0.8
"HEAT" Speed	Tap 1	196	222	269	295	334	363	386	429
	Tap 2	282	317	373	403	440	486	512	545
	Tap 3	409	442	484	528	582	619	661	714
	Tap 4	824	851	891	936	1,024	980	1,000	993
First Stage "COOL" Speed	Tap 1	91	116	146	166	189	213	243	267
	Tap 2	110	148	173	205	232	261	280	309
	Tap 3	160	201	227	253	286	316	348	374
	Tap 4	270	314	358	397	440	476	516	536
Second Stage "COOL" Speed	Tap 1	200	231	265	298	337	354	383	425
	Tap 2	293	333	380	421	448	487	519	560
	Tap 3	403	441	489	546	589	639	678	717
	Tap 4	778	806	896	943	1,000	999	981	986

AT "NORM" SETTING ("Adjust" Jumper at NORM Setting)

Jumper Speed Positions		Motor Watts @ Various External Static Pressures - in. wg.							
		0.1	0.2	0.3	0.4	0.5	0.6	0.7	0.8
"HEAT" Speed	Tap 1	151	185	215	251	283	316	347	369
	Tap 2	219	258	300	328	371	407	439	473
	Tap 3	315	360	414	450	489	523	562	607
	Tap 4	572	604	690	732	774	826	856	913
First Stage "COOL" Speed	Tap 1	76	99	121	139	165	199	221	243
	Tap 2	106	124	150	172	199	226	255	279
	Tap 3	125	162	195	222	255	281	306	330
	Tap 4	223	247	299	317	353	390	430	458
Second Stage "COOL" Speed	Tap 1	147	188	222	250	281	309	340	367
	Tap 2	224	274	306	347	374	415	441	482
	Tap 3	301	347	399	443	470	525	550	597
	Tap 4	581	629	678	742	795	843	900	959

AT "-" (Minus) SETTING ("Adjust" Jumper at "-" Setting)

Jumper Speed Positions		Motor Watts @ Various External Static Pressures - in. wg.							
		0.1	0.2	0.3	0.4	0.5	0.6	0.7	0.8
"HEAT" Speed	Tap 1	115	154	183	209	230	264	283	318
	Tap 2	170	210	238	269	307	340	363	397
	Tap 3	238	282	321	352	394	416	455	496
	Tap 4	416	469	522	569	609	648	695	741
First Stage "COOL" Speed	Tap 1	58	82	101	126	144	168	196	231
	Tap 2	80	110	139	151	178	201	225	258
	Tap 3	99	129	154	180	205	227	258	290
	Tap 4	179	218	248	284	308	349	377	394
Second Stage "COOL" Speed	Tap 1	115	153	178	204	234	258	285	306
	Tap 2	175	214	244	271	310	340	370	398
	Tap 3	244	285	338	372	408	429	467	501
	Tap 4	421	461	520	563	619	665	700	748

BLOWER DATA

CBX25UHV-060 BLOWER PERFORMANCE

0 through 0.80 in. w.g. External Static Pressure Range

"ADJUST" Jumper Setting	Jumper Speed Positions											
	"HEAT" Speed				First Stage "COOL" Speed				Second Stage "COOL" Speed			
	1	2	3	4	1	2	3	4	1	2	3	4
	cfm	cfm	cfm	cfm	cfm	cfm	cfm	cfm	cfm	cfm	cfm	cfm
+	1700	1930	2120	2275	1225	1410	1530	1690	1720	1930	2140	2270
NORM	1570	1760	1925	2100	1120	1260	1400	1540	1580	1765	1970	2100
-	1420	1595	1760	1920	1015	1160	1275	1390	1430	1625	1780	1890

NOTES - The effect of static pressure, filter and electric heater resistance is included in the air volumes listed.

First stage cooling air volume is 70% of COOL speed setting. Continuous blower speed is approximately 50% of COOL speed setting.

Lennox Harmony III™ Zoning System applications - minimum blower speed is 450 cfm.

CBX25UHV-060 BLOWER MOTOR WATTS

AT "+" (Plus) SETTING ("Adjust" Jumper at "+" Setting)

Jumper Speed Positions		Motor Watts @ Various External Static Pressures - in. wg.							
		0.1	0.2	0.3	0.4	0.5	0.6	0.7	0.8
"HEAT" Speed	Tap 1	309	354	391	431	463	507	545	564
	Tap 2	456	503	556	600	642	682	718	744
	Tap 3	612	672	732	783	819	874	918	949
	Tap 4	812	859	917	972	988	981	947	939
First Stage "COOL" Speed	Tap 1	125	151	187	216	237	276	312	359
	Tap 2	170	210	243	277	307	342	371	410
	Tap 3	234	271	307	342	385	408	440	470
	Tap 4	301	348	386	422	460	489	532	561
Second Stage "COOL" Speed	Tap 1	313	363	409	429	484	509	553	594
	Tap 2	461	510	552	602	633	677	731	750
	Tap 3	607	660	713	765	802	857	891	937
	Tap 4	778	834	898	943	1,005	968	949	950

AT "NORM" SETTING ("Adjust" Jumper at NORM Setting)

Jumper Speed Positions		Motor Watts @ Various External Static Pressures - in. wg.							
		0.1	0.2	0.3	0.4	0.5	0.6	0.7	0.8
"HEAT" Speed	Tap 1	234	274	315	353	385	417	451	490
	Tap 2	331	387	412	473	515	545	571	617
	Tap 3	477	508	561	611	649	693	717	765
	Tap 4	593	631	703	751	821	833	875	930
First Stage "COOL" Speed	Tap 1	98	127	150	172	178	244	285	316
	Tap 2	124	162	186	228	247	287	330	373
	Tap 3	175	207	246	280	310	338	374	427
	Tap 4	224	270	306	342	368	416	467	467
Second Stage "COOL" Speed	Tap 1	246	289	330	363	400	428	472	512
	Tap 2	358	399	442	467	503	559	601	633
	Tap 3	490	546	584	636	671	680	765	806
	Tap 4	568	623	674	732	787	838	878	925

AT "-" (Minus) SETTING ("Adjust" Jumper at "-" Setting)

Jumper Speed Positions		Motor Watts @ Various External Static Pressures - in. wg.							
		0.1	0.2	0.3	0.4	0.5	0.6	0.7	0.8
"HEAT" Speed	Tap 1	177	215	249	289	312	349	389	411
	Tap 2	260	293	340	369	409	438	486	518
	Tap 3	349	389	446	476	513	558	587	633
	Tap 4	436	498	528	592	635	658	702	737
First Stage "COOL" Speed	Tap 1	64	86	123	157	189	219	250	278
	Tap 2	101	137	159	189	228	278	288	328
	Tap 3	136	165	194	219	259	297	316	374
	Tap 4	171	211	240	278	308	334	367	402
Second Stage "COOL" Speed	Tap 1	200	231	259	294	319	365	385	436
	Tap 2	265	300	349	384	414	458	496	531
	Tap 3	357	398	442	487	527	563	604	637
	Tap 4	429	485	531	573	605	664	686	740

ELECTRIC HEAT DATA

SINGLE PHASE		CBX25UHV-018					
Description	Input			Blower Motor Full Load Amps	² Minimum Circuit Ampacity	³ Maximum Overcurrent Protection	
	Volt	kW	¹ Btuh				
2.5 kW ECB25-2.5 (12R08) Wire Leads	208	1.9	6,400	3.9	16	20	
	220	2.1	7,200	3.9	17	20	
	230	2.3	7,800	3.9	17	20	
	240	2.5	8,500	3.9	18	20	
5 kW ECB25-5 (12R45) Terminal Block ECB25-5CB (12R60) 30A Circuit Breaker	208	3.8	12,800	3.9	27	30	
	220	4.2	14,300	3.9	29	30	
	230	4.6	15,700	3.9	30	30	
	240	5.0	17,100	3.9	31	35	
7.5 kW ECB25-7.5 (12R61) Terminal Block ECB25-7.5CB (12S08) 45A Circuit Breaker	208	5.6	19,200	3.9	39	40	
	220	6.3	21,500	3.9	41	45	
	230	6.9	23,500	3.9	42	45	
	240	7.5	25,600	3.9	44	45	
10 kW ECB25-10 (12S59) Terminal Block ECB25-10CB (12S60) 60A Circuit Breaker	208	6.8	23,000	3.9	45	45	
	220	7.6	25,800	3.9	48	50	
	230	8.3	28,200	3.9	50	50	
	240	9.0	30,700	3.9	52	60	
SINGLE PHASE		CBX25UHV-024					
Description	Input			Blower Motor Full Load Amps	² Minimum Circuit Ampacity	³ Maximum Overcurrent Protection	
	Volt	kW	¹ Btuh				
2.5 kW ECB25-2.5 (12R08) Wire Leads	208	1.9	6,400	3.9	16	20	
	220	2.1	7,200	3.9	17	20	
	230	2.3	7,800	3.9	17	20	
	240	2.5	8,500	3.9	18	20	
5 kW ECB25-5 (12R45) Terminal Block ECB25-5CB (12R60) 30A Circuit Breaker	208	3.8	12,800	3.9	27	30	
	220	4.2	14,300	3.9	29	30	
	230	4.6	15,700	3.9	30	30	
	240	5.0	17,100	3.9	31	35	
7.5 kW ECB25-7.5 (12R61) Terminal Block ECB25-7.5CB (12S08) 45A Circuit Breaker	208	5.6	19,200	3.9	39	40	
	220	6.3	21,500	3.9	41	45	
	230	6.9	23,500	3.9	42	45	
	240	7.5	25,600	3.9	44	45	
10 kW ECB25-10 (12S59) Terminal Block ECB25-10CB (12S60) 60A Circuit Breaker	208	6.8	23,000	3.9	45	45	
	220	7.6	25,800	3.9	48	50	
	230	8.3	28,200	3.9	50	50	
	240	9.0	30,700	3.9	52	60	

NOTE - Circuit 1 Minimum Circuit Ampacity includes the Blower Motor Full Load Amps.

¹ Electric heater capacity only - does not include additional blower motor heat capacity.

² Refer to National or Canadian Electrical Code manual to determine wire, fuse and disconnect size requirements. Use wires suitable for at least 167°F.

³ HACR type breaker or fuse.

⁴ **Bold indicates that the circuit breaker on "CB" circuit breaker models must be replaced with size shown. See table on page 17.**

ELECTRIC HEAT DATA

SINGLE PHASE		CBX25UHV-030									
		Input			Blower Motor Full Load Amps	² Minimum Circuit Ampacity		³ Maximum Overcurrent Protection		Single Point Power Source	
		Volt	kW	¹ Btuh		Ckt 1	Ckt 2	Ckt 1	Ckt 2	² Minimum Circuit Ampacity	³ Maximum Overcurrent Protection
2.5 kW	ECB25-2.5 (12R08) Wire Leads	208	1.9	6,400	3.9	16	---	20	---	---	---
		220	2.1	7,200	3.9	17	---	20	---	---	---
		230	2.3	7,800	3.9	17	---	20	---	---	---
		240	2.5	8,500	3.9	18	---	20	---	---	---
5 kW	ECB25-5 (12R45) Terminal Block ECB25-5CB (12S60) 30A Circuit Breaker	208	3.8	12,800	3.9	27	---	30	---	---	---
		220	4.2	14,300	3.9	29	---	30	---	---	---
		230	4.6	15,700	3.9	30	---	30	---	---	---
		240	5.0	17,100	3.9	31	---	⁴ 35	---	---	---
7.5 kW	ECB25-7.5 (12R61) Terminal Block ECB25-7.5CB (12S08) 45A Circuit Breaker	208	5.6	19,200	3.9	39	---	⁴ 40	---	---	---
		220	6.3	21,500	3.9	41	---	45	---	---	---
		230	6.9	23,500	3.9	42	---	45	---	---	---
		240	7.5	25,600	3.9	44	---	45	---	---	---
10 kW	ECB25-10 (12S59) Terminal Block ECB25-10CB (12S60) 60A Circuit Breaker	208	6.8	23,000	3.9	45	---	⁴ 45	---	---	---
		220	7.6	25,800	3.9	48	---	⁴ 50	---	---	---
		230	8.3	28,200	3.9	50	---	⁴ 50	---	---	---
		240	9.0	30,700	3.9	52	---	60	---	---	---
12.5 kW	ECB25-12.5CB (12S77) (1) 60A and (1) 30A Circuit Breaker	208	9.4	32,000	3.9	42	23	⁴ 45	⁴ 25	65	70
		220	10.5	35,800	3.9	45	24	⁴ 45	⁴ 25	68	70
		230	11.5	39,200	3.9	46	25	⁴ 50	⁴ 25	71	80
		240	12.5	42,600	3.9	48	26	⁴ 50	30	74	80
15 kW	ECB25-15CB (12S87) (1) 60A and (1) 30A Circuit Breaker	208	11.3	38,400	3.9	25	45	⁴ 50	30	72	80
		220	12.6	43,000	3.9	26	48	⁴ 50	30	76	80
		230	13.5	47,000	3.9	27	50	⁴ 50	30	80	80
		240	15.0	51,200	3.9	28	52	60	⁴ 35	83	90

NOTE - Circuit 1 Minimum Circuit Ampacity includes the Blower Motor Full Load Amps.

¹ Electric heater capacity only - does not include additional blower motor heat capacity.

² Refer to National or Canadian Electrical Code manual to determine wire, fuse and disconnect size requirements. Use wires suitable for at least 167°F.

³ HACR type breaker or fuse.

⁴ Bold indicates that the circuit breaker on "CB" circuit breaker models must be replaced with size shown. See table on page 17.

ELECTRIC HEAT DATA

SINGLE PHASE		CBX25UHV-036									
Description	Input			Blower Motor Full Load Amps	² Minimum Circuit Ampacity		³ Maximum Overcurrent Protection		Single Point Power Source		
	Volt	kW	¹ Btuh		Ckt 1	Ckt 2	Ckt 1	Ckt 2	² Minimum Circuit Ampacity	³ Maximum Overcurrent Protection	
2.5 kW	ECB25-2.5 (12R08) Wire Leads	208	1.9	6,400	3.9	16	---	20	---	---	---
		220	2.1	7,200	3.9	17	---	20	---	---	---
		230	2.3	7,800	3.9	17	---	20	---	---	---
		240	2.5	8,500	3.9	18	---	20	---	---	---
5 kW	ECB25-5 (12R45) Terminal Block ECB25-5CB (12S60) 30A Circuit Breaker	208	3.8	12,800	3.9	27	---	30	---	---	---
		220	4.2	14,300	3.9	29	---	30	---	---	---
		230	4.6	15,700	3.9	30	---	30	---	---	---
		240	5.0	17,100	3.9	31	---	⁴ 35	---	---	---
7.5 kW	ECB25-7.5 (12R61) Terminal Block ECB25-7.5CB (12S08) 45A Circuit Breaker	208	5.6	19,200	3.9	39	---	⁴ 40	---	---	---
		220	6.3	21,500	3.9	41	---	45	---	---	---
		230	6.9	23,500	3.9	42	---	45	---	---	---
		240	7.5	25,600	3.9	44	---	45	---	---	---
10 kW	ECB25-10 (12S59) Terminal Block ECB25-10CB (12S60) 60A Circuit Breaker	208	6.8	23,000	3.9	45	---	⁴ 45	---	---	---
		220	7.6	25,800	3.9	48	---	⁴ 50	---	---	---
		230	8.3	28,200	3.9	50	---	⁴ 50	---	---	---
		240	9.0	30,700	3.9	52	---	60	---	---	---
12.5 kW	ECB25-12.5CB (12S77) (1) 60A and (1) 30A Circuit Breaker	208	9.4	32,000	3.9	42	23	⁴ 45	⁴ 25	65	70
		220	10.5	35,800	3.9	45	24	⁴ 45	⁴ 25	68	70
		230	11.5	39,200	3.9	46	25	⁴ 50	⁴ 25	71	80
		240	12.5	42,600	3.9	48	26	⁴ 50	30	74	80
15 kW	ECB25-15CB (12S87) (1) 60A and (1) 30A Circuit Breaker	208	11.3	38,400	3.9	25	45	⁴ 50	30	72	80
		220	12.6	43,000	3.9	26	48	⁴ 50	30	76	80
		230	13.5	47,000	3.9	27	50	⁴ 50	30	80	80
		240	15.0	51,200	3.9	28	52	60	⁴ 35	83	90

NOTE - Circuit 1 Minimum Circuit Ampacity includes the Blower Motor Full Load Amps.

¹ Electric heater capacity only - does not include additional blower motor heat capacity.

² Refer to National or Canadian Electrical Code manual to determine wire, fuse and disconnect size requirements. Use wires suitable for at least 167°F.

³ HACR type breaker or fuse.

⁴ Bold indicates that the circuit breaker on "CB" circuit breaker models must be replaced with size shown. See table on page 17.

ELECTRIC HEAT DATA

SINGLE PHASE		CBX25UHV-042									
Description	Input			Blower Motor Full Load Amps	² Minimum Circuit Ampacity		³ Maximum Overcurrent Protection		Single Point Power Source		
	Volt	kW	¹ Btuh		Ckt 1	Ckt 2	Ckt 1	Ckt 2	² Minimum Circuit Ampacity	³ Maximum Overcurrent Protection	
2.5 kW ECB25-2.5 (12R08) Wire Leads	208	1.9	6,400	5.2	18	---	20	---	---	---	
	220	2.1	7,200	5.2	18	---	20	---	---	---	
	230	2.3	7,800	5.2	19	---	20	---	---	---	
	240	2.5	8,500	5.2	20	---	20	---	---	---	
5 kW ECB25-5 (12R45) Terminal Block ECB25-5CB (12S60) 30A Circuit Breaker	208	3.8	12,800	5.2	29	---	30	---	---	---	
	220	4.2	14,300	5.2	30	---	30	---	---	---	
	230	4.6	15,700	5.2	32	---	⁴ 35	---	---	---	
	240	5.0	17,100	5.2	33	---	⁴ 35	---	---	---	
7.5 kW ECB25-7.5 (12R61) Terminal Block ECB25-7.5CB (12S08) 45A Circuit Breaker	208	5.6	19,200	5.2	40	---	⁴ 40	---	---	---	
	220	6.3	21,500	5.2	42	---	45	---	---	---	
	230	6.9	23,500	5.2	44	---	45	---	---	---	
	240	7.5	25,600	5.2	46	---	⁴ 50	---	---	---	
10 kW ECB25-10 (12S59) Terminal Block ECB25-10CB (12S60) 60A Circuit Breaker	208	6.8	23,000	5.2	47	---	⁴ 50	---	---	---	
	220	7.6	25,800	5.2	49	---	⁴ 50	---	---	---	
	230	8.3	28,200	5.2	52	---	60	---	---	---	
	240	9.0	30,700	5.2	53	---	60	---	---	---	
12.5 kW ECB25-12.5CB (12S77) (1) 60A and (1) 30A Circuit Breaker	208	9.4	32,000	5.2	44	23	⁴ 45	⁴ 25	67	70	
	220	10.5	35,800	5.2	46	24	⁴ 50	⁴ 25	70	70	
	230	11.5	39,200	5.2	48	25	⁴ 50	⁴ 25	73	80	
	240	12.5	42,600	5.2	50	26	⁴ 50	30	76	80	
15 kW ECB25-15CB (12S87) (1) 60A and (1) 30A Circuit Breaker	208	11.3	38,400	5.2	29	45	⁴ 50	30	74	80	
	220	12.6	43,000	5.2	30	48	⁴ 50	30	78	80	
	230	13.5	47,000	5.2	32	50	⁴ 50	⁴ 35	82	90	
	240	15.0	51,200	5.2	33	52	60	⁴ 35	85	90	

NOTE - Circuit 1 Minimum Circuit Ampacity includes the Blower Motor Full Load Amps.

¹ Electric heater capacity only - does not include additional blower motor heat capacity.

² Refer to National or Canadian Electrical Code manual to determine wire, fuse and disconnect size requirements. Use wires suitable for at least 167°F.

³ HACR type breaker or fuse.

⁴ **Bold indicates that the circuit breaker on "CB" circuit breaker models must be replaced with size shown. See table on page 17.**

ELECTRIC HEAT DATA

SINGLE PHASE		CBX25UHV-048, CBX25UHV-060									
		Input			Blower Motor Full Load Amps	² Minimum Circuit Ampacity		³ Maximum Overcurrent Protection		Single Point Power Source	
		Volt	kW	¹ Btuh		Ckt 1	Ckt 2	Ckt 1	Ckt 2	² Minimum Circuit Ampacity	³ Maximum Overcurrent Protection
5 kW	ECB25-5 (12R45) Terminal Block ECB25-5CB (12R60) 30A Circuit Breaker	208	3.8	12,800	6.9	31	---	⁴ 35	---	---	---
		220	4.2	14,300	6.9	32	---	⁴ 35	---	---	---
		230	4.6	15,700	6.9	34	---	⁴ 35	---	---	---
		240	5.0	17,100	6.9	35	---	⁴ 35	---	---	---
7.5 kW	ECB25-7.5 (12R61) Terminal Block ECB25-7.5CB (12S08) 45A Circuit Breaker	208	5.6	19,200	6.9	42	---	45	---	---	---
		220	6.3	21,500	6.9	44	---	45	---	---	---
		230	6.9	23,500	6.9	46	---	⁴ 50	---	---	---
		240	7.5	25,600	6.9	48	---	⁴ 50	---	---	---
10 kW	ECB25-10 (12S59) Terminal Block ECB25-10CB (12S60) 60A Circuit Breaker	208	6.8	23,000	6.9	49	---	⁴ 50	---	---	---
		220	7.6	25,800	6.9	52	---	60	---	---	---
		230	8.3	28,200	6.9	54	---	60	---	---	---
		240	9.0	30,700	6.9	56	---	60	---	---	---
12.5 kW	ECB25-12.5CB (12S77) (1) 60A and (1) 30A Circuit Breaker	208	9.4	32,000	6.9	46	23	⁴ 50	⁴ 25	69	70
		220	10.5	35,800	6.9	48	24	⁴ 50	⁴ 25	72	80
		230	11.5	39,200	6.9	50	25	⁴ 50	⁴ 25	75	80
		240	12.5	42,600	6.9	52	26	60	30	78	80
15 kW	ECB25-15CB (12S87) (1) 60A and (1) 30A Circuit Breaker	208	11.3	38,400	6.9	31	45	⁴ 50	⁴ 35	76	80
		220	12.6	43,000	6.9	32	48	⁴ 50	⁴ 35	80	80
		230	13.5	47,000	6.9	34	50	⁴ 50	⁴ 35	84	90
		240	15.0	51,200	6.9	35	52	60	⁴ 35	87	90
20 kW	ECB25-20CB (12S88) (1) 60A and (1) 60A Circuit Breaker	208	15.0	51,200	6.9	50	49	⁴ 50	⁴ 50	99	100
		220	16.8	57,300	6.9	53	52	60	60	104	110
		230	18.4	62,700	6.9	55	54	60	60	109	110
		240	20.0	68,200	6.9	57	56	60	60	113	125

NOTE - Circuit 1 Minimum Circuit Ampacity includes the Blower Motor Full Load Amps.

¹ Electric heater capacity only - does not include additional blower motor heat capacity.

² Refer to National or Canadian Electrical Code manual to determine wire, fuse and disconnect size requirements. Use wires suitable for at least 167°F.

³ HACR type breaker or fuse.

⁴ Bold indicates that the circuit breaker on "CB" circuit breaker models must be replaced with size shown. See table on page 17.

REPLACEMENT CIRCUIT BREAKERS

Voltage	Description	Catalog No.
208/240V - 1 Phase	25 amp, 2 pole	41K13
	30 amp, 2 pole	17K70
	35 amp, 2 pole	72K07
	40 amp, 2 pole	49K14
	45 amp, 2 pole	17K71
	50 amp, 2 pole	41K12
	60 amp, 2 pole	17K72

DIMENSIONS - UNIT - UPFLOW - INCHES (MM)

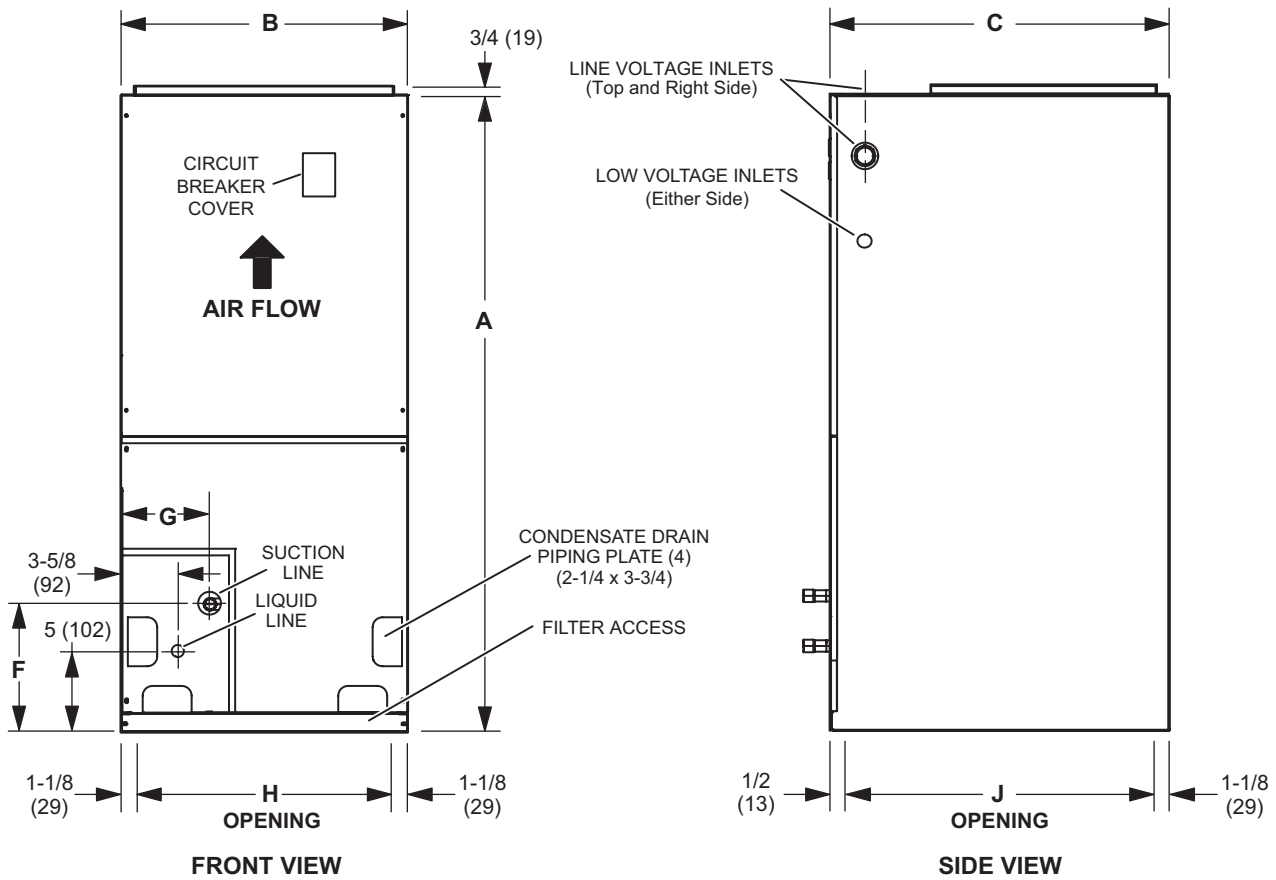
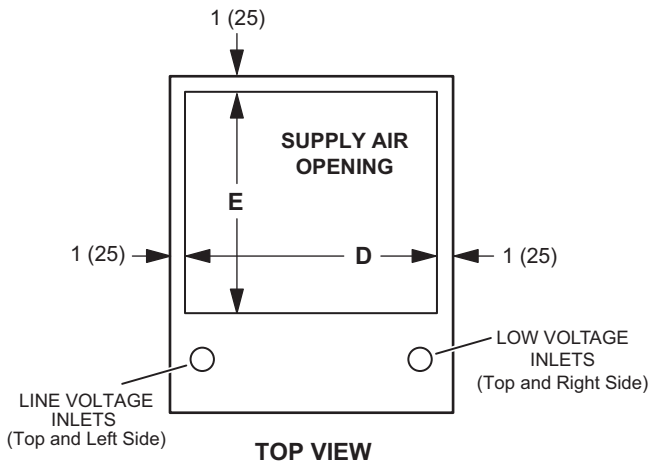

Dimension	018		024		030		036		042		048-060	
	in.	mm	in.	mm	in.	mm	in.	mm	in.	mm	in.	mm
A	38	965	40-1/2	1029	43	1092	48	1219	48	1219	52-1/2	1334
B	15	381	18-1/2	470	18-1/2	470	21-7/8	556	21-7/8	556	21-7/8	556
C	22	559	22	559	22	559	22	559	26-1/4	667	26-1/4	667
D	13	330	16-1/2	419	16-1/2	419	19-7/8	505	19-7/8	505	19-7/8	505
E	14-1/2	368	14-1/2	368	14-1/2	368	14-1/2	368	18-3/4	476	18-3/4	476
F	8	203	8	203	8	203	8	203	9-1/4	235	9-1/4	235
G	5-5/8	143	5-5/8	143	5-5/8	143	5-5/8	143	4-1/2	114	4-1/2	114
H	12-3/4	324	16-1/4	413	16-1/4	413	19-5/8	498	19-5/8	498	19-5/8	498
J	20-3/8	518	20-3/8	518	20-3/8	518	20-3/8	518	24-5/8	625	24-5/8	625

DIMENSIONS - UNIT - HORIZONTAL - INCHES (MM)

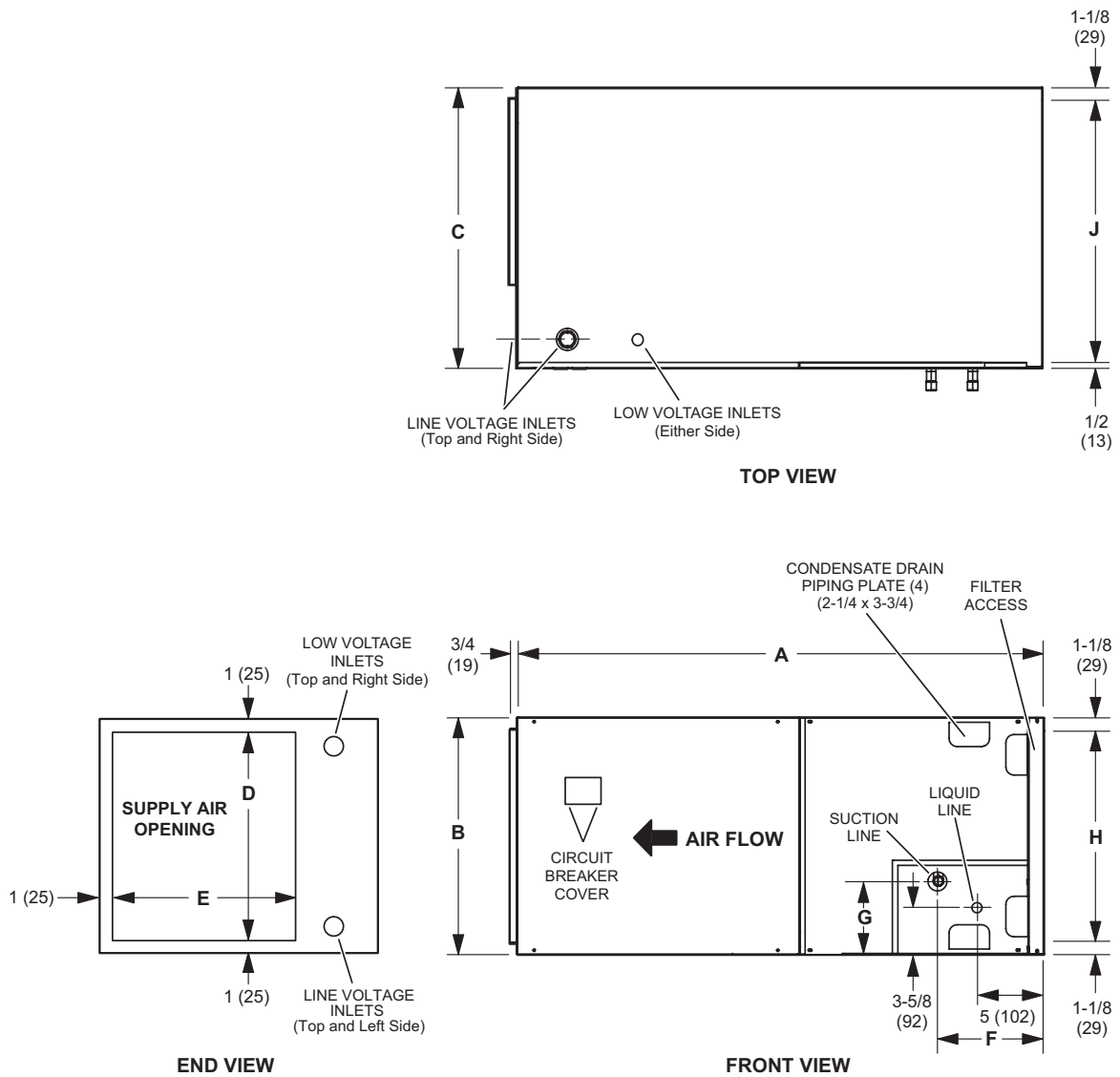

NOTE - Shipped for horizontal left-hand discharge.
 May be field converted to horizontal right-hand air discharge by repositioning horizontal drain pan.

Dimension	018		024		030		036		042		048-060	
	in.	mm	in.	mm	in.	mm	in.	mm	in.	mm	in.	mm
A	38	965	40-1/2	1029	43	1092	48	1219	48	1219	52-1/2	1334
B	15	381	18-1/2	470	18-1/2	470	21-7/8	556	21-7/8	556	21-7/8	556
C	22	559	22	559	22	559	22	559	26-1/4	667	26-1/4	667
D	13	330	16-1/2	419	16-1/2	419	19-7/8	505	19-7/8	505	19-7/8	505
E	14-1/2	368	14-1/2	368	14-1/2	368	14-1/2	368	18-3/4	476	18-3/4	476
F	8	203	8	203	8	203	8	203	9-1/4	235	9-1/4	235
G	5-5/8	143	5-5/8	143	5-5/8	143	5-5/8	143	4-1/2	114	4-1/2	114
H	12-3/4	324	16-1/4	413	16-1/4	413	19-5/8	498	19-5/8	498	19-5/8	498
J	20-3/8	518	20-3/8	518	20-3/8	518	20-3/8	518	24-5/8	625	24-5/8	625

DIMENSIONS - ACCESSORIES - INCHES (MM)

SIDE RETURN UNIT STAND
(Upflow Only)

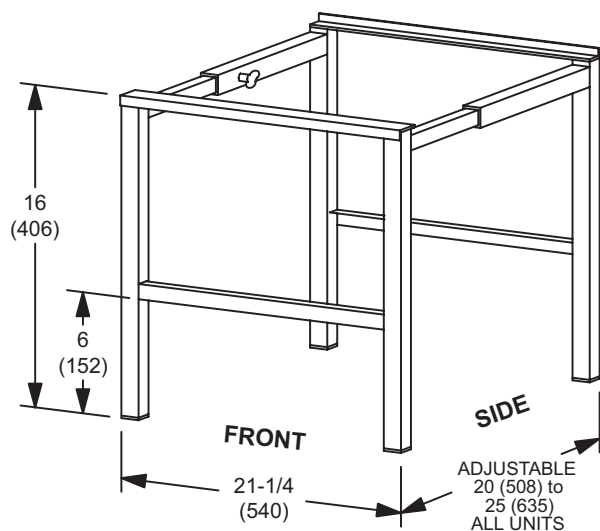

INSTALLATION CLEARANCES WITH ELECTRIC HEAT

Cabinet	0 inch (0 mm)
To Plenum	0 inch (0 mm)
To Outlet Duct within 3 feet (914 mm)	0 inch (0 mm)
Floor	0 inch (0 mm)
Service / Maintenance	See Note #1

¹ Front service access - 24 inches (610 mm) minimum.

NOTE - If cabinet depth is more than 24 inches (610 mm), allow a minimum of the cabinet depth plus 2 inches (51 mm).

REVISIONS

Sections	Description of Change
Electrical / Electric Heat Data	MCA and MOCP values updated for 12.5 and 15 kW electric heaters.



Visit us at www.lennox.com

For the latest technical information, www.LennoxPROs.com

Contact us at 1-800-4-LENNOX

NOTE - Due to Lennox' ongoing commitment to quality, Specifications, Ratings and Dimensions subject to change without notice and without incurring liability. Improper installation, adjustment, alteration, service or maintenance can cause property damage or personal injury. Installation and service must be performed by a qualified installer and servicing agency.

©2018 Lennox Industries, Inc.