



AIR HANDLERS

CBX32MV

DAVE LENNOX SIGNATURE® COLLECTION
R-410A Ready - Multi-Position - Variable Speed

PRODUCT SPECIFICATIONS

Bulletin No. 210352
February 2018
Supersedes November 2017



Nominal Capacity - 1.5 to 5+ Tons
Optional Electric Heat - 2.5 to 25 kW

MODEL NUMBER IDENTIFICATION

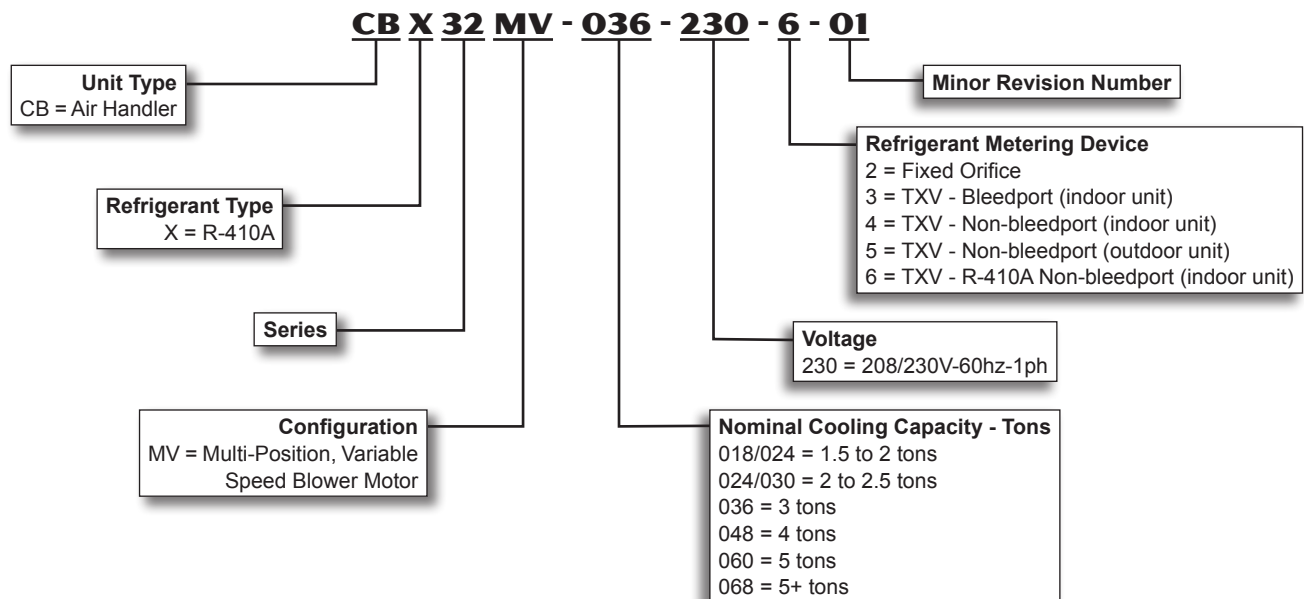

FEATURES

CONTENTS

Blower Data	10
Dimensions - Downflow	21
Dimensions - Upflow.....	20
Electrical Data.....	8
Electric Heat Data.....	15
Features.....	2
Installation Clearances With Electric Heat.....	8
Model Number Identification	1
Optional Accessories	8
Replacement Circuit Breakers	9
Specifications.....	8

WARRANTY

All covered components - Limited ten years in residential applications, one year in non-residential applications.

Refer to Lennox Limited Warranty Certificate included with each unit for additional details.

APPROVALS

Tested with matching air conditioners and heat pump units in the Lennox Research Laboratory environmental test room in accordance with AHRI Standard 210/240.

Optional electric heaters are rated in accordance with US Department of Energy (DOE) test procedures and Federal Trade Commission (FTC) labeling regulations.

Blower performance data according to unit tests conducted in Lennox air test chamber.

Air handlers are UL Listed to US and Canadian safety standards and components within are bonded for grounding to meet safety standards for servicing required by CEC and NEC.

Air handler units are approved for installation in manufactured housing and mobile homes.

ISO 9001 Registered Manufacturing Quality System.

APPLICATIONS

1.5 to 5+ ton nominal sizes.

Multi-position (upflow, downflow or horizontal) applications.

Applicable to expansion valve systems in R-410A cooling applications and check and expansion valve systems in R-410A heat pump applications.

Applicable to Lennox' iHarmony® Zoning System.

Wide-range check and expansion valve is factory installed.

See bulletins in section Air Conditioners for cooling capacities.

See bulletins in section Heat Pump Outdoor Units for cooling and heating capacities.

Optional field installed electric heaters available in several sizes for additive heating capacity.

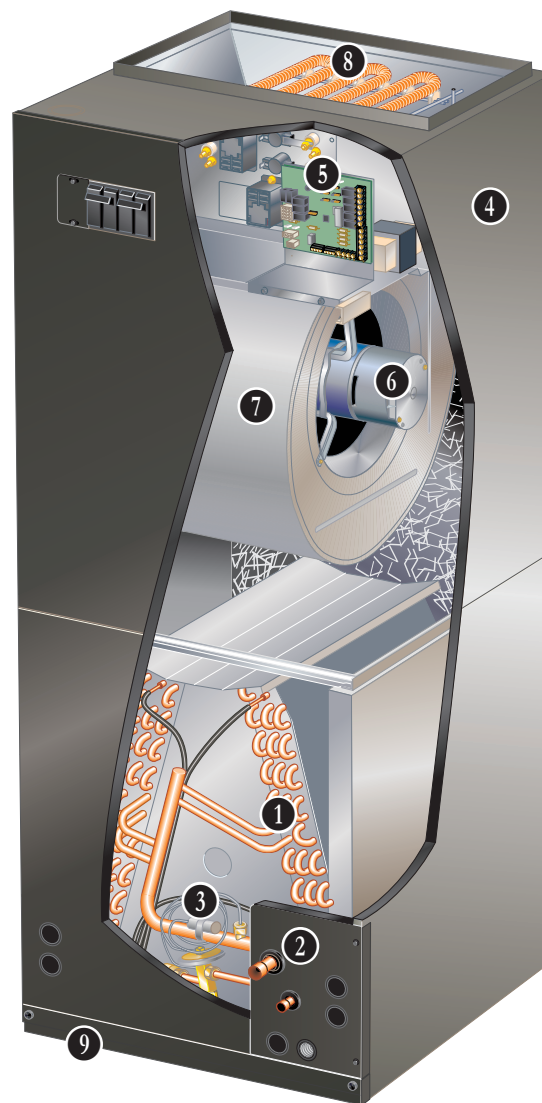

Zoning Applications

Units can be used with certain zoning systems. Zone control panel **MUST** be able to interface and communicate with the variable speed motor in the unit. Lennox iHarmony® Zoning System has this capability.

REFRIGERANT SYSTEM

1 Copper Tube/Enhanced Fin Indoor Coil

Lennox designed and fabricated twin coils.

Assembled in "A" configuration.

Provides extra large surface and contact area, excellent heat transfer and low air resistance for maximum efficiency.

Precise circuiting for uniform refrigerant distribution.

Precisely spaced ripple-edged aluminum fins fitted to durable seamless copper tubes.

Fins are strengthened to resist bending and are equipped with collars that grip tubing for maximum contact area.

Lanced fins provide maximum exposure of fin surface to air stream.

Long life copper tubing is easy to service.

Rifled tubing provides superior heat transfer.

FEATURES

REFRIGERANT SYSTEM (continued)

Flared shoulder tubing joints and silver soldering provide tight, leakproof joints.

Coil thoroughly factory tested under high pressure to insure leakproof construction.

2 Refrigerant Line Connections

Suction (vapor) and liquid lines have sweat connections that extended outside of the cabinet for ease of connection.

See dimension drawings for locations.

3 Check and Expansion Valve Furnished

For use with R-410A systems.

Wide range valve with Chatleff style fitting.

Factory installed on all models, internal to cabinet.



CABINET

4 Constructed of heavy-gauge galvanized steel.

Completely insulated with thick fiberglass insulation.

Pre-painted steel cabinets have mildly textured enamel finish with primer coat on unpainted side of all panels.

Units are shipped in one piece but may be disassembled into two separate sections for ease of installation in tight applications. See dimension drawings.

Thick rubber gasket between sections of the two piece cabinets provides an air tight seal.

No external screw heads on sides of cabinet for tight installations without damage to walls or woodwork.

Removable panels provide complete service access.

Electrical inlets provided in sides and top of cabinet. See dimension drawings for locations.

Low Leakage Cabinet

All models have less than 2% air leakage and meet ANSI/ASHRAE Standard 193-2010 "Method of Test for Determining the Air Tightness of HVAC Equipment".

Multi-Position Capability

Shipped for upflow and horizontal right-hand discharge.

Quickly converted to downflow or left-hand, horizontal air discharge.

Easily converts to downflow position with furnished coil support rails and filter support rack.

Dual Position Drain Pans

Drain pans designed for upflow, downflow or horizontal applications.

Deep, corrosion resistant plastic drain pans have dual pipe drains.

See dimension drawings.

Optional Accessories

Downflow Combustible Flooring Base

Base is required for models with electric heat installed in downflow position on combustible floors.

Horizontal Support Frame Kit (Not for -068)

Provides support of unit in horizontal applications.

Consists of (2) 1 x 1-1/2 x 32-5/8 in. and (2) 1 x 3 x 53-7/8 in. painted heavy gauge cold rolled steel support channels with assembly and suspending holes.

Bolts and nuts furnished for field assembly.

Suspending rods must be field provided.

Side Return Unit Stand (Upflow Only, Not for -068)

Raises unit 16 in. above floor for side return air duct connection.

Eliminates need for wooden platform construction.

All aluminum construction.

Two adjustable frames fit -018/024 thru -060 models.

Wall Hanging Bracket Kit (Upflow Only)

Allows unit to be hung on wall at any height.

Consists of heavy-gauge steel support brackets (one for air handler, one for wall mount).

Screws furnished for fastening one bracket to unit.

Bolts for fastening one bracket to wall are field provided.

High Performance Economizer (Commercial Applications Only)

Designed for applications requiring outdoor air to be utilized in a commercial HVAC system. Allows the entry of fresh outdoor air for free cooling, reducing the requirement for mechanical cooling.

Heavy gauge galvanized steel cabinet lined with thick fiberglass insulation.

Mixed air sensor, outdoor air sensor and 24VAC transformer furnished.

Approved for California Title 24 building standards.

ASHRAE 90.1-2010 compliant.

See separate Product Specifications bulletin for additional information and available control and sensor options.

NOTE - Economizer is not iComfort® Communicating compatible.

FEATURES

CONTROLS

5 iComfort® Communicating Control

Advanced control board communicates information about various operating parameters in the air handler to the optional iComfort® Communicating Thermostat to constantly maintain the highest level of comfort, performance and efficiency available.

Auto Configuration - On start-up the control board automatically sends a description of the unit to the optional iComfort® Communicating Thermostat to automatically configure the number of stages and features available.

Connections for a conventional heating/cooling thermostat are also provided on the board.

Board also features:

- Lennox Humiditrol® Whole Home Dehumidification System (EDA) compatible.
- EEPROM storage of all local configurations.
- Non-volatile memory storage of 100 alarm codes with display of last 10 codes for troubleshooting.
- Connections for optional outdoor temperature sensor (communicates temperature on RSBUS to thermostat).
- Controls evaporator humidity by controlling blower and compressor staging on two-stage outdoor units.
- Two stages - HEAT and COOL (with four different air volume selections for each) are made by simple jumper pins on board.
- ADJUST jumper pin allows approximately 10% higher, normal or 10% lower motor speed selection within HEAT and COOL speeds selected for fine tuning air volume.
- DELAY jumper pin allows selection of blower motor de-humidification profiles during cooling mode.

Option 1 - Motor runs at 100% of capacity until demand met. Once demand is met, motor ramps down to stop.

Option 2 - Cooling: When cool demand is initiated, motor ramps up to 100% and runs at 100% until demand is satisfied. Once demand is met, motor runs at 100% for 45 seconds, then ramps down to stop.

Heat Pump: When heat pump demand is initiated, 30 second motor on delay starts. After the motor on delays expires, motor ramps up to 100% and runs at 100% until demand is satisfied. Once demand is met, motor runs at 100% for 45 seconds, then ramps down to stop.

Option 3 - Motor runs at 82% of capacity for approximately 7.5 minutes, then 100% capacity (if needed) until demand is satisfied. Once demand is met, motor ramps down to stop.

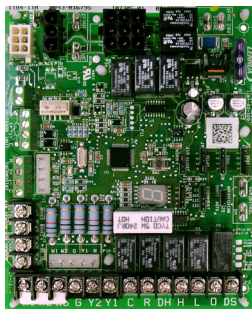

Option 4 - Motor runs at 50% capacity for 30 seconds, then 82% capacity for approximately 7.5 minutes. If demand is not satisfied, motor runs at 100% capacity until demand is met. Once demand is met, motor runs at 50% capacity for 30 seconds, then ramps down to stop.

Display LED - Seven segment LED displays alpha-numeric information related to diagnostics as well as system operation and status. Diagnostic codes are held in non-volatile memory, immune from power interruptions. Holds up to ten diagnostic codes in order of occurrence for recall on demand. Port on blower door allows for easy viewing.

Dehumidification (Active or Humiditrol® Option) - A jumper on the control board must be clipped to enable active dehumidification and/or operation with a Humiditrol Whole-Home Dehumidification System. A humidity controlling thermostat or device is also required. During a call for cooling, air volume is automatically reduced, forcing humidity removal by the air conditioner or heat pump system. After the humidity has reached the desired set-point the cooling air volume returns to its designed rate. A dehumidification signal from the thermostat reduces the cooling cfm to 70% of the requested cooling cfm.

Electric Heat Operation - Control for up to three electric heat stages.

EvenHeater® Electric Heat Control - Up to four electric heat stages are available when utilizing the EvenHeater® control feature furnished on the iComfort® Communicating Control. EVENHEAT jumper position on control board determines target discharge air temperature of 85°F, 100°F, 115°F or 130°F. Default setting is 85°F. An optional Discharge Air Sensor is required.

Heat Pump Operation - A jumper on the control board must be clipped to enable operation with a single or two-stage heat pump. The indoor blower is started without delay when a call for heat is received.

Two Stage Cooling Operation - A jumper on the control board must be clipped to enable operation with a two-stage air conditioner. The cooling blower speeds for first and second stage cooling will be dictated by the applicable DIP switch settings.

Lennox System Operations Monitor Connection - Monitors outdoor unit operation. (communicating mode).

Continuous Blower Speed - Adjustable continuous blower speed is a percentage of the high cooling speed selection. There are four selectable options (via DIP switch settings) of 28%, 38% (default setting), 70% and 100%.

Transformer - 70VA transformer furnished as standard. Factory installed in the unit control box.

Accessory Terminal - One 24 volt humidifier output is furnished for non-powered humidifiers. Control board is factory installed in the unit control box.

FEATURES

CONTROLS (continued)

Optional Accessories

iComfort® S30 Ultra-Smart Thermostat (part of the iComfort® Residential Communicating Control System)

The *iComfort® S30 Thermostat* recognizes and connects to all iComfort® Communicating products to automatically configure and control the heating/cooling system (based on user-specified settings) for the highest level of comfort, performance and efficiency. Also recognizes model and serial number information for iComfort® Communicating products to simplify system setup.

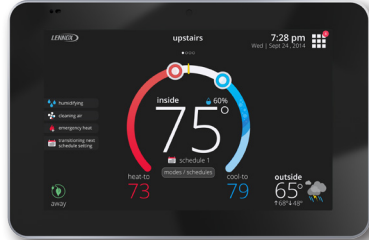

Wi-Fi remote temperature monitoring and adjustment through a home wireless network for desktop PCs, laptops and apps for smartphones or tablets. Also displays service alerts and reminders.

Dealer Dashboard features online real-time monitoring of installed iComfort® Communicating systems.

A simple easy-to-use touchscreen allows complete system configuration. Scheduled maintenance alerts, system warnings and troubleshooting are also displayed on thermostat screen.

Easy to read 7 in. high definition color display (measured diagonally).

Works with Amazon® Alexa-enabled products.

Conventional outdoor units (not iComfort® Communicating) can easily be added and controlled by the iComfort® S30 Thermostat.

Installer setup screens allow quick and simple system configuration without a manual, Installer can also run tests on complete system or individual components for easy maintenance and troubleshooting.

Serial communications bus (RSBus), with less wiring than a conventional heating/cooling system, allows system communication. Uses 4-wire, 18-gauge standard thermostat wiring.

High Definition Color Display, Mag-Mount, Smart Hub Controller, wallplate (for retrofit installations) furnished for easy installation.

See the *iComfort® S30 Thermostat* Product Specifications bulletin in the Controls section for more information.

iComfort Wi-Fi® Thermostat (part of the iComfort® Residential Communicating Control System)

The *iComfort Wi-Fi® Thermostat* recognizes and connects to all iComfort® Communicating products to automatically configure and control the heating/cooling system (based on user-specified settings) for the highest level of comfort, performance and efficiency. Also recognizes model and serial number information for iComfort® Communicating products to simplify system setup.



Wi-Fi remote temperature monitoring and adjustment through a home wireless network for desktop PCs, laptops and apps for smartphones or tablets. Also displays service alerts and reminders.

Dealer Dashboard features online real-time monitoring of installed iComfort® Communicating systems.

A simple easy-to-use touchscreen allows complete system configuration. Scheduled maintenance alerts, system warnings and troubleshooting are also displayed on thermostat screen.

Easy to read 7-inch color screen (measured diagonally).

Conventional outdoor units (not iComfort® Communicating) can easily be added and controlled by the iComfort Wi-Fi® Thermostat.

Installer setup screens allow quick and simple system configuration without a manual, Installer can also run tests on complete system or individual components for easy maintenance and troubleshooting.

Serial communications bus (RSBus), with less wiring than a conventional heating/cooling system, allows system communication. Uses 4-wire, 18-gauge standard thermostat wiring.

See the *iComfort Wi-Fi® Thermostat* Product Specifications bulletin in the Controls section for more information.

FEATURES

CONTROLS (continued)

ComfortSense® 7500 Touchscreen Thermostat

Electronic 7-day, universal, multi-stage, programmable, touchscreen thermostat.

4 Heat/2 Cool.

Auto-changeover.

Dual-fuel control with optional outdoor sensor.

Controls dehumidification during cooling mode and humidification during heating mode.

Offers enhanced capabilities including humidification / dehumidification / dewpoint measurement and control, *Humiditrol*® control, and equipment maintenance reminders.

Easy-to-use, menu driven thermostat with a back-lit, LCD touchscreen.

See the *ComfortSense*® 7500 Product Specifications bulletin in the Controls section for more information.

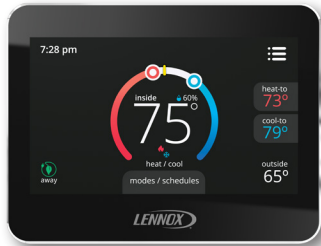

Remote Outdoor Temperature Sensor

Used with the iComfort® Communicating Thermostats and ComfortSense® 7500 thermostat.

When installed outdoors, sensor allows thermostat to display outdoor temperature. Sensor is auto-detected when connected to thermostat.

NOTE - Sensor is required for Humiditrol® applications.

NOTE - The outdoor sensor is furnished as standard with iComfort® Communicating outdoor units, optional for conventional units.



Thermostat

Thermostat (iComfort® Communicating Thermostat or programmable/non-programmable) is not furnished with unit.

See Thermostat bulletins in Controls Section and Lennox Price Book for selection.

Hot Water Heat Kit

Air handler kit to control a third-party hot water boiler with a hot water heating coil installed downstream from the air handler.

Kit contains all necessary relays and plug-in wiring harness to control boiler.

NOTE - This kit is only approved for use in systems using either the ComfortSense® 7500 or iComfort® Communicating thermostats.

BLOWER

6 Variable-Speed Blower Motor

High efficiency multi-speed blower motor maintains specified air volumes up to a maximum of 0.8 in. w.g. total external static.

Multi-speed operation is achieved by the use of an ECM (Electronically Commutated Motor) motor.

Allows cooling ramping profiles (field selectable) for enhanced dehumidification.

Motor accelerates and decelerates gradually, reducing start-up and shut-down sound.

Leadless blower motor features simple plug-in connections.

Motor is controlled by the iComfort® Communicating Control that allows blower to operate at two of eight air volumes or speeds available.

Speeds may be field selected on iComfort® Communicating Control depending on size of air handler and air volume desired.

See blower performance tables.



7 Blower Assembly

Lennox designed and built, direct drive blower.

Each blower is statically and dynamically balanced as an assembly before installation in the unit.

Blower motor is resiliently mounted to blower assembly.

Blower slides out of cabinet for servicing.

FEATURES

OPTIONAL ELECTRIC HEAT

- 8 Field install internal to unit cabinet.
Available in several voltages and kW sizes.
See Electric Heat tables.
Helix wound nichrome heating elements exposed directly in air stream resulting in instant heat transfer, low element temperatures and long service life.
Each element equipped with accurately located limit control with fixed temperature off setting and automatic reset.
Supplemental thermal cutoff limit control, provides positive protection in case of excessive temperatures.
Thermal sequencer relay brings elements on and off line, in sequence and equal increments, with time delay between each.
Initiates and terminates blower operation.
Heating control relay(s) furnished as standard.
Control box and access cover constructed of heavy gauge galvanized steel.
Factory assembled with controls installed and wired.
Electric heat low voltage controls plug-in to air handler.

Circuit Breaker Models

The following heaters are equipped with circuit breakers for overload and short circuit protection:

ECB40-4CB, -5CB, -6CB, -8CB, -9CB, -12.5CB, -15CB, -20CB and -25CB (208/240V-1ph)

ECB40-15CB, -20CB and -25CB (208/240V-3ph)

Factory wired and mounted on electric heat unit.

Current sensitive and temperature actuated.

Manual reset.

Circuit breakers qualify as disconnect means at unit in many areas, eliminate the need for field provided disconnect.

Consult local electrical code in your area.

Optional Accessories

Circuit Breaker Cover Kit

Flexible plastic cover protects circuit breaker.

Recommended in areas with high humidity or unconditioned areas to prevent nuisance tripping.

Single-Point Power Source Control Box

Control Box may be used with optional electric heat when single power supply is connected to multi-circuit electric heat.

Field installs external to the unit cabinet on either side or top.

Constructed of heavy gauge steel, baked enamel finish, prepunched mounting holes, electrical inlet knockouts, and terminal strip.

Removable cover provides easy access.

Dimensions (H x W x D) - 7 x 7 x 4 in.

INDOOR AIR QUALITY

9 Air Filter

Tool-less access to filter area for quick and easy servicing.

Disposable frame type filter furnished and factory installed in rails in cabinet.

See Specifications tables for sizes.

Optional Accessories

Healthy Climate® Germicidal UVC Light



Germicidal lamp emits C-Band ultra-violet (UVC) energy at 253.7 nanometers, which is proven to be effective in reducing microbes such as viruses, bacteria, yeasts, and molds. This process either destroys the organism or controls its ability to reproduce. UVC germicidal light greatly reduces the growth and proliferation of mold and other bioaerosols (bacteria and viruses) on illuminated surfaces (particularly coil and drain pan). Surfaces must be cleaned prior to UVC light being installed.

Available in 24 volt and 110/230V-1ph models.

Air handlers have a factory provided knockout in the coil delta plate for mounting light within coil area.

Shielding baffle is required when installing light above a non-UVC resistant component, such as a filter.

Baffle must be ordered separately.

SPECIFICATIONS

General Data		Model Number	CBX32MV-018/024	CBX32MV-024/030	CBX32MV-036
	Nominal tonnage		1.5 to 2	2 to 2.5	3
	Refrigerant		R-410A	R-410A	R-410A
Connections in.	Suction / vapor (o.d.) line - sweat		5/8	3/4	3/4
	Liquid line (o.d.) - sweat		3/8	3/8	3/8
	Condensate drain - in. (fpt)		(2) 3/4	(2) 3/4	(2) 3/4
Indoor Coil	Net face area - ft. ²		3.56	4.44	5.0
	Tube outside diameter - in.		3/8	3/8	3/8
	Number of rows		3	3	3
	Fins per inch		12	12	12
Blower Data	Wheel nominal diameter x width - in.		10 x 7	10 x 8	10 x 8
	Motor output - hp		1/2	1/2	1/2
Filters	¹ Number and size - in.		(1) 15 x 20 x 1	(1) 20 x 20 x 1	(1) 20 x 20 x 1
Shipping Data - 1 Package - lbs.			126	152	183

ELECTRICAL DATA

	Voltage - phase - 60hz	208/230V-1ph	208/230V-1ph	208/230V-1ph
	² Maximum overcurrent protection (unit only)	15	15	15
	³ Minimum circuit ampacity (unit only)	5	5	5

CONTROLS

iComfort® S30 Thermostat	12U67	12U67	12U67
iComfort Wi-Fi® Thermostat	10F81	10F81	10F81
ComfortSense® 7500 Thermostat	13H14	13H14	13H14
⁴ Remote Outdoor Sensor (for dual fuel and Humiditrol®)	X2658	X2658	X2658
⁵ Discharge Temperature Sensor	88K38	88K38	88K38

OPTIONAL ACCESSORIES - ORDER SEPARATELY

Circuit Breaker Cover Kit	82W01	82W01	82W01
Downflow Combustible Flooring Base	34J72	44K15	44K15
Electric Heat	See Electric Heat Data tables		
Healthy Climate Germicidal Light	UVC-24V (24V)	X9423	X9423
	Shielding Baffle (required)	Y5172	Y5172
	UVC-41W-S (110/230v-1 ph)	X9424	X9424
	Shielding Baffle (required)	Y5171	Y5171
Horizontal Support Frame Kit	56J18	56J18	56J18
Hot Water Heat Kit	90W84	90W84	90W84
Side Return Unit Stand (Upflow)	45K31	45K32	45K32
Single-Point Power Source Control Box	21H39	21H39	21H39
Wall Hanging Bracket Kit (Upflow)	45K30	45K30	45K30
High Performance Economizer (Commercial Only)	10U53	10U53	10U53

¹ Disposable frame type filter.

² HACR type circuit breaker or fuse.

³ Refer to National or Canadian Electrical Code manual to determine wire, fuse and disconnect size requirements. Use wires suitable for at least 167°F.

⁴ Remote Outdoor Temperature Sensor is used with conventional (non-iComfort® Communicating) outdoor units (sensor is furnished with iComfort® Communicating outdoor units). Allows the thermostat to display outdoor temperature. Required in dual-fuel and Humiditrol® applications.

⁵ Optional for EvenHeater® electric heat operation and service diagnostics.

INSTALLATION CLEARANCES WITH ELECTRIC HEAT

Cabinet	0 inch (0 mm)
To Plenum	1 inch (25 mm)
To Outlet Duct within 3 feet (914 mm)	1 inch (25 mm)
Floor	See Note #1
Service / Maintenance	See Note #2

¹ Units installed on combustible floors in the downflow position with electric heat require optional downflow combustible flooring base.

² Front service access - 24 inches (610 mm) minimum.

NOTE - If cabinet depth is more than 24 inches (610 mm), allow a minimum of the cabinet depth plus 2 inches (51 mm).

SPECIFICATIONS

General Data		Model Number	CBX32MV-048	CBX32MV-060	CBX32MV-068
	Nominal tonnage		4	5	5+
	Refrigerant		R-410A	R-410A	R-410A
Connections in.	Suction / vapor (o.d.) line - sweat		7/8	7/8	1-1/8
	Liquid line (o.d.) - sweat		3/8	3/8	3/8
	Condensate drain - in. (fpt)		(2) 3/4	(2) 3/4	(2) 3/4
Indoor Coil	Net face area - ft. ²		7.22	7.22	7.77
	Tube outside diameter - in.		3/8	3/8	3/8
	Number of rows		3	3	3
	Fins per inch		12	12	12
Blower Data	Wheel nominal diameter x width - in.		12 x 9	12 x 9	15 x 9
	Motor output - hp		1	1	1
Filters	¹ Number and size - in.		(1) 20 x 24 x 1	(1) 20 x 24 x 1	(1) 20 x 25 x 1
Shipping Data - 1 Package - lbs.			212	212	244

ELECTRICAL DATA

Voltage - phase - 60hz		208/230V-1ph	208/230V-1ph	208/230V-1ph
² Maximum overcurrent protection (unit only)		20	20	20
³ Minimum circuit ampacity (unit only)		11	11	11

CONTROLS

iComfort® S30 Thermostat		12U67	12U67	12U67
iComfort Wi-Fi® Thermostat		10F81	10F81	10F81
ComfortSense® 7500 Thermostat		13H14	13H14	13H14
⁴ Remote Outdoor Sensor (for dual fuel and Humiditrol®)		X2658	X2658	X2658
⁵ Discharge Temperature Sensor		88K38	88K38	88K38

OPTIONAL ACCESSORIES - ORDER SEPARATELY

Circuit Breaker Cover Kit		82W01	82W01	82W01
Downflow Additive Base		44K15	44K15	44K15
Electric Heat		See Electric Heat Data tables		
Healthy Climate Germicidal Light	UVC-24V (24V)	X9423	X9423	X9423
	Shielding Baffle (required)	Y5172	Y5172	Y5172
	UVC-41W-S (110/230v-1 ph)	X9424	X9424	X9424
	Shielding Baffle (required)	Y5171	Y5171	Y5171
Horizontal Support Frame Kit		56J18	56J18	N/A
Hot Water Heat Kit		90W84	90W84	90W84
Side Return Unit Stand (Upflow)		45K32	45K32	N/A
Single-Point Power Source Control Box		21H39	21H39	21H39
Wall Hanging Bracket Kit (Upflow)		45K30	45K30	45K30
High Performance Economizer (Commercial Only)		10U53	10U53	10U53

¹ Disposable frame type filter.

² HACR type circuit breaker or fuse.

³ Refer to National or Canadian Electrical Code manual to determine wire, fuse and disconnect size requirements. Use wires suitable for at least 167°F.

⁴ Remote Outdoor Temperature Sensor is used with conventional (non-iComfort® Communicating) outdoor units (sensor is furnished with iComfort® Communicating outdoor units). Allows the thermostat to display outdoor temperature. Required in dual-fuel and Humiditrol® applications.

⁵ Optional for EvenHeater® electric heat operation and service diagnostics.

REPLACEMENT CIRCUIT BREAKERS

Voltage	Description	Catalog No.
208/240V - 1 Phase	25 amp, 2 pole	41K13
	30 amp, 2 pole	17K70
	35 amp, 2 pole	72K07
	40 amp, 2 pole	49K14
	45 amp, 2 pole	17K71
	50 amp, 2 pole	41K12
	60 amp, 2 pole	17K72
208/240V - 3 Phase	30 amp, 3 pole	64W47
	35 amp, 3 pole	41K14
	40 amp, 3 pole	41K16
	45 amp, 3 pole	18M86
	50 amp, 3 pole	41K15
	60 amp, 3 pole	41K17

BLOWER DATA

CBX32MV-018/024 BLOWER PERFORMANCE

0 through 0.80 in. w.g. External Static Pressure Range

“ADJUST” Jumper Setting	Jumper Speed Positions							
	“HEAT” Speed				“COOL” Speed			
	1 cfm	2 cfm	3 cfm	4 cfm	1 cfm	2 cfm	3 cfm	4 cfm
+	715	855	1000	1130	465	690	900	1050
NORM	670	770	900	1035	425	620	825	950
-	580	700	800	930	385	560	735	850

NOTES - The effect of static pressure, filter and electric heater resistance is included in the air volumes listed.

First stage cooling air volume is 70% of COOL speed setting. Continuous fan speed is approximately 28%, 38%, 70% and 100% (Jumper selectable) of the same second-stage COOL speed selected, minimum 250 cfm.

Lennox iHarmony® Zoning System applications - minimum blower speed is 250 cfm.

CBX32MV-018/024 BLOWER MOTOR WATTS

AT “+” (Plus) SETTING (“Adjust” Jumper at “+” Setting)

Jumper Speed Positions		Motor Watts @ Various External Static Pressures - in. wg.								
		0	0.1	0.2	0.3	0.4	0.5	0.6	0.7	0.8
“HEAT” Speed	Tap 1	100	113	126	142	154	172	190	206	230
	Tap 2	155	176	197	221	237	260	278	295	310
	Tap 3	237	260	289	305	314	337	356	373	390
	Tap 4	338	361	379	409	433	457	447	426	406
“COOL” Speed	Tap 1	36	47	61	71	81	95	106	118	135
	Tap 2	89	103	118	129	143	163	177	197	207
	Tap 3	183	198	229	248	266	290	307	327	343
	Tap 4	266	294	315	330	349	373	390	411	401

AT “NORM” SETTING (“Adjust” Jumper at NORM Setting)

Jumper Speed Positions		Motor Watts @ Various External Static Pressures - in. wg.								
		0	0.1	0.2	0.3	0.4	0.5	0.6	0.7	0.8
“HEAT” Speed	Tap 1	77	96	106	123	130	150	165	178	201
	Tap 2	118	136	154	177	189	212	224	247	265
	Tap 3	183	198	224	248	264	284	307	321	343
	Tap 4	264	284	300	326	343	367	385	406	390
“COOL” Speed	Tap 1	30	41	55	62	76	86	94	106	114
	Tap 2	71	83	101	113	125	138	156	166	185
	Tap 3	137	158	176	199	219	238	254	273	296
	Tap 4	211	225	249	272	295	318	331	342	367

AT “-” (Minus) SETTING (“Adjust” Jumper at “-” Setting)

Jumper Speed Positions		Motor Watts @ Various External Static Pressures - in. wg.								
		0	0.1	0.2	0.3	0.4	0.5	0.6	0.7	0.8
“HEAT” Speed	Tap 1	59	73	89	106	113	130	142	156	173
	Tap 2	95	106	118	136	152	171	183	200	215
	Tap 3	132	148	171	186	211	225	248	266	284
	Tap 4	195	217	242	259	283	302	314	336	349
“COOL” Speed	Tap 1	27	35	47	59	71	77	88	92	106
	Tap 2	57	65	83	94	110	119	134	148	166
	Tap 3	110	124	141	157	176	188	213	231	242
	Tap 4	148	170	195	207	230	248	272	282	306

BLOWER DATA

CBX32MV-024/030 BLOWER PERFORMANCE

0 through 0.80 in. w.g. External Static Pressure Range

"ADJUST" Jumper Setting	Jumper Speed Positions							
	"HEAT" Speed				"COOL" Speed			
	1 cfm	2 cfm	3 cfm	4 cfm	1 cfm	2 cfm	3 cfm	4 cfm
+	800	935	1070	1210	660	880	1100	1320
NORM	725	850	975	1100	600	800	1000	1200
-	655	765	880	990	540	720	900	1080

NOTES - The effect of static pressure, filter and electric heater resistance is included in the air volumes listed.

First stage cooling air volume is 70% of COOL speed setting. Continuous fan speed is approximately 28%, 38%, 70% and 100% (Jumper selectable) of the same second-stage COOL speed selected, minimum 250 cfm.

Lennox iHarmony® Zoning System applications - minimum blower speed is 250 cfm.

CBX32MV-024/030 BLOWER MOTOR WATTS

AT "+" (Plus) SETTING ("Adjust" Jumper at "+" Setting)

Jumper Speed Positions		Motor Watts @ Various External Static Pressures - in. wg.								
		0	0.1	0.2	0.3	0.4	0.5	0.6	0.7	0.8
"HEAT" Speed	Tap 1	65	90	120	145	185	210	240	250	275
	Tap 2	95	125	150	185	230	265	310	345	365
	Tap 3	140	190	225	250	290	320	350	405	450
	Tap 4	215	250	285	315	350	390	440	480	505
"COOL" Speed	Tap 1	45	60	90	120	140	155	165	185	200
	Tap 2	80	110	135	165	205	250	285	315	335
	Tap 3	150	195	225	260	295	320	370	425	465
	Tap 4	265	315	350	400	440	485	525	555	605

AT "NORM" SETTING ("Adjust" Jumper at NORM Setting)

Jumper Speed Positions		Motor Watts @ Various External Static Pressures - in. wg.								
		0	0.1	0.2	0.3	0.4	0.5	0.6	0.7	0.8
"HEAT" Speed	Tap 1	50	75	100	135	155	180	195	215	230
	Tap 2	80	105	130	155	200	245	265	295	310
	Tap 3	110	150	175	200	235	275	320	350	390
	Tap 4	155	205	230	270	290	325	360	405	460
"COOL" Speed	Tap 1	40	55	80	105	120	130	150	165	180
	Tap 2	65	90	120	145	190	210	240	260	285
	Tap 3	105	145	175	220	250	285	335	370	405
	Tap 4	200	245	275	300	335	385	420	470	515

AT "-" (Minus) SETTING ("Adjust" Jumper at "-" Setting)

Jumper Speed Positions		Motor Watts @ Various External Static Pressures - in. wg.								
		0	0.1	0.2	0.3	0.4	0.5	0.6	0.7	0.8
"HEAT" Speed	Tap 1	45	65	90	110	130	150	165	190	195
	Tap 2	60	85	110	145	175	200	215	235	240
	Tap 3	85	105	130	165	210	245	280	305	330
	Tap 4	115	145	175	205	230	280	325	370	390
"COOL" Speed	Tap 1	30	50	70	90	100	115	125	140	165
	Tap 2	55	75	100	135	155	185	190	210	225
	Tap 3	85	115	135	175	210	255	295	320	345
	Tap 4	145	175	215	245	280	325	355	410	450

BLOWER DATA

CBX32MV-036 BLOWER PERFORMANCE

0 through 0.80 in. w.g. External Static Pressure Range

"ADJUST" Jumper Setting	Jumper Speed Positions							
	"HEAT" Speed				"COOL" Speed			
	1 cfm	2 cfm	3 cfm	4 cfm	1 cfm	2 cfm	3 cfm	4 cfm
+	1230	1335	1445	1545	900	1225	1380	1545
NORM	1120	1215	1315	1400	810	1125	1275	1400
-	1010	1185	1200	1265	730	1000	1135	1265

NOTES - The effect of static pressure, filter and electric heater resistance is included in the air volumes listed.

First stage cooling air volume is 70% of COOL speed setting. Continuous fan speed is approximately 28%, 38%, 70% and 100% (Jumper selectable) of the same second-stage COOL speed selected, minimum 250 cfm.

Lennox iHarmony® Zoning System applications - minimum blower speed is 250 cfm.

CBX32MV-036 BLOWER MOTOR WATTS

AT "+" (Plus) SETTING ("Adjust" Jumper at "+" Setting)

Jumper Speed Positions		Motor Watts @ Various External Static Pressures - in. wg.								
		0	0.1	0.2	0.3	0.4	0.5	0.6	0.7	0.8
"HEAT" Speed	Tap 1	220	235	265	290	310	335	360	385	465
	Tap 2	285	305	330	355	380	405	430	450	475
	Tap 3	345	365	405	430	455	485	515	545	570
	Tap 4	470	495	515	530	545	560	575	595	610
"COOL" Speed	Tap 1	90	110	135	155	180	195	210	230	250
	Tap 2	225	245	265	290	320	350	370	395	410
	Tap 3	305	325	350	390	420	445	475	505	535
	Tap 4	470	495	515	530	545	560	575	595	610

AT "NORM" SETTING ("Adjust" Jumper at NORM Setting)

Jumper Speed Positions		Motor Watts @ Various External Static Pressures - in. wg.								
		0	0.1	0.2	0.3	0.4	0.5	0.6	0.7	0.8
"HEAT" Speed	Tap 1	155	185	215	240	265	285	300	335	355
	Tap 2	225	245	270	295	325	345	370	390	415
	Tap 3	275	290	315	340	375	400	420	445	465
	Tap 4	320	345	375	405	435	460	485	515	540
"COOL" Speed	Tap 1	100	120	140	150	185	190	215	240	250
	Tap 2	160	190	220	240	265	290	320	340	365
	Tap 3	255	270	295	320	345	375	400	420	445
	Tap 4	320	345	375	405	435	460	485	515	540

AT "-" (Minus) SETTING ("Adjust" Jumper at "-" Setting)

Jumper Speed Positions		Motor Watts @ Various External Static Pressures - in. wg.								
		0	0.1	0.2	0.3	0.4	0.5	0.6	0.7	0.8
"HEAT" Speed	Tap 1	120	135	165	185	205	225	245	265	300
	Tap 2	140	165	195	215	245	270	300	315	335
	Tap 3	185	210	240	265	285	310	330	360	385
	Tap 4	245	255	290	310	335	355	380	405	430
"COOL" Speed	Tap 1	65	90	105	125	145	160	185	190	215
	Tap 2	120	140	160	185	215	235	255	275	295
	Tap 3	160	190	225	240	275	295	320	350	380
	Tap 4	245	255	290	310	335	355	380	405	430

BLOWER DATA

CBX32MV-048 and cbx32MV-060 BLOWER PERFORMANCE

0 through 0.80 in. w.g. External Static Pressure Range

"ADJUST" Jumper Setting	Jumper Speed Positions							
	"HEAT" Speed				"COOL" Speed			
	1	2	3	4	1	2	3	4
	cfm	cfm	cfm	cfm	cfm	cfm	cfm	cfm
+	1850	1960	2090	2150	1625	1820	2055	2145
NORM	1705	1800	1900	2005	1425	1625	1805	2005
-	1560	1625	1720	1770	1205	1375	1555	1725

NOTES - The effect of static pressure, filter and electric heater resistance is included in the air volumes listed.

First stage cooling air volume is 70% of COOL speed setting. Continuous fan speed is approximately 28%, 38%, 70% and 100% (Jumper selectable) of the same second-stage COOL speed selected, minimum 450 cfm.

Lennox iHarmony® Zoning System applications - minimum blower speed is 450 cfm.

CBX32MV-048 and cbx32MV-060 BLOWER MOTOR WATTS

AT "+" (Plus) SETTING ("Adjust" Jumper at "+" Setting)

Jumper Speed Positions		Motor Watts @ Various External Static Pressures - in. wg.								
		0	0.1	0.2	0.3	0.4	0.5	0.6	0.7	0.8
"HEAT" Speed	Tap 1	455	505	540	585	630	665	710	745	780
	Tap 2	555	595	645	675	730	780	820	865	895
	Tap 3	680	720	770	820	865	900	945	985	1030
	Tap 4	730	780	825	870	920	970	1020	1055	1110
"COOL" Speed	Tap 1	300	335	370	360	435	465	500	535	575
	Tap 2	425	475	500	545	585	635	670	710	745
	Tap 3	625	660	705	755	810	850	885	940	970
	Tap 4	700	750	800	845	895	940	990	1030	1080

AT "NORM" SETTING ("Adjust" Jumper at NORM Setting)

Jumper Speed Positions		Motor Watts @ Various External Static Pressures - in. wg.								
		0	0.1	0.2	0.3	0.4	0.5	0.6	0.7	0.8
"HEAT" Speed	Tap 1	360	385	425	465	495	525	565	600	635
	Tap 2	400	440	485	520	555	595	640	670	705
	Tap 3	480	520	560	605	640	685	765	785	805
	Tap 4	580	625	665	710	760	800	835	875	925
"COOL" Speed	Tap 1	215	235	275	295	330	360	400	430	465
	Tap 2	310	335	375	405	440	465	500	530	565
	Tap 3	415	445	490	535	565	605	650	675	715
	Tap 4	580	610	655	695	740	785	830	870	910

AT "-" (Minus) SETTING ("Adjust" Jumper at "-" Setting)

Jumper Speed Positions		Motor Watts @ Various External Static Pressures - in. wg.								
		0	0.1	0.2	0.3	0.4	0.5	0.6	0.7	0.8
"HEAT" Speed	Tap 1	265	305	340	370	410	440	460	505	540
	Tap 2	320	350	395	420	450	475	515	545	580
	Tap 3	375	410	435	470	515	545	575	610	645
	Tap 4	400	435	480	525	555	595	640	670	700
"COOL" Speed	Tap 1	140	170	195	215	250	275	300	335	360
	Tap 2	200	230	260	285	315	355	385	415	450
	Tap 3	280	315	340	380	415	445	465	505	540
	Tap 4	375	420	440	475	515	550	575	610	645

BLOWER DATA

CBX32MV-068 BLOWER PERFORMANCE

0 through 0.80 in. w.g. External Static Pressure Range

"ADJUST" Jumper Setting	Jumper Speed Positions							
	"HEAT" Speed				"COOL" Speed			
	1 cfm	2 cfm	3 cfm	4 cfm	1 cfm	2 cfm	3 cfm	4 cfm
+	1875	1975	2090	2150	1640	1840	2075	2150
NORM	1760	1825	1920	2030	1465	1625	1800	2000
-	1550	1650	1725	1800	1250	1390	1560	1720

NOTES - The effect of static pressure, filter and electric heater resistance is included in the air volumes listed.

First stage cooling air volume is 70% of COOL speed setting. Continuous fan speed is approximately 28%, 38%, 70% and 100% (Jumper selectable) of the same second-stage COOL speed selected, minimum 450 cfm.

Lennox iHarmony® Zoning System applications - minimum blower speed is 450 cfm.

CBX32MV-068 BLOWER MOTOR WATTS

AT "+" (Plus) SETTING ("Adjust" Jumper at "+" Setting)

Jumper Speed Positions		Motor Watts @ Various External Static Pressures - in. wg.								
		0	0.1	0.2	0.3	0.4	0.5	0.6	0.7	0.8
"HEAT" Speed	Tap 1	365	410	455	495	545	610	660	725	790
	Tap 2	430	485	540	590	640	690	765	835	865
	Tap 3	540	585	635	695	750	800	815	840	865
	Tap 4	665	710	755	770	790	810	830	845	870
"COOL" Speed	Tap 1	255	290	320	365	415	455	505	550	590
	Tap 2	355	390	425	475	515	580	630	695	750
	Tap 3	505	565	610	70	715	790	815	845	865
	Tap 4	725	745	755	770	790	810	830	850	870

AT "NORM" SETTING ("Adjust" Jumper at NORM Setting)

Jumper Speed Positions		Motor Watts @ Various External Static Pressures - in. wg.								
		0	0.1	0.2	0.3	0.4	0.5	0.6	0.7	0.8
"HEAT" Speed	Tap 1	310	345	385	425	465	510	560	610	665
	Tap 2	345	385	420	460	500	620	615	680	735
	Tap 3	385	430	480	525	580	640	695	750	815
	Tap 4	475	525	560	615	660	720	785	845	810
"COOL" Speed	Tap 1	180	205	240	285	325	365	405	435	480
	Tap 2	250	285	320	355	410	455	505	535	585
	Tap 3	345	375	415	460	505	560	610	670	735
	Tap 4	445	510	560	595	665	725	790	845	865

AT "-" (Minus) SETTING ("Adjust" Jumper at "-" Setting)

Jumper Speed Positions		Motor Watts @ Various External Static Pressures - in. wg.								
		0	0.1	0.2	0.3	0.4	0.5	0.6	0.7	0.8
"HEAT" Speed	Tap 1	215	245	285	325	375	415	460	495	540
	Tap 2	255	295	325	370	410	460	510	545	580
	Tap 3	295	330	375	395	445	495	555	600	660
	Tap 4	335	370	400	445	505	550	600	660	705
"COOL" Speed	Tap 1	125	150	170	210	245	270	300	340	370
	Tap 2	160	185	225	255	300	335	365	415	450
	Tap 3	225	245	280	320	370	420	460	510	545
	Tap 4	290	325	355	400	445	490	545	595	650

ELECTRIC HEAT DATA - CBX32MV-018/024

Model Number	No. of Stages	Volts Input	kW Input	¹ Btuh Input	² Blower Motor Full Load Amps	³ Minimum Circuit Ampacity	⁵ Maximum Overcurrent Protection	
SINGLE PHASE								
2.5 kW 4 lbs.	ECB40-2.5 (12L68) Terminal Block	1	208	1.9	6,400	4.0	16	20
			220	2.1	7,200	4.0	17	20
			230	2.3	7,800	4.0	18	20
			240	2.5	8,500	4.0	18	20
4 kW 4 lbs.	ECB40-4 (12L76) Terminal Block ECB40-4CB (12L78) 30A Circuit breaker	1	208	3.0	10,250	4.0	23	⁴ 25
			220	3.4	11,450	4.0	24	⁴ 25
			230	3.7	12,550	4.0	25	⁴ 25
			240	4.0	13,650	4.0	26	30
5 kW 4 lbs.	ECB40-5 (12L79) Terminal Block ECB40-5CB (12L88) 35A Circuit breaker	1	208	3.8	12,800	4.0	28	⁴ 30
			220	4.2	14,300	4.0	29	⁴ 30
			230	4.6	15,700	4.0	30	⁴ 30
			240	5.0	17,100	4.0	31	35
6 kW 4 lbs.	EB40-6 (12L86) Terminal Block ECB40-6CB (12L89) 40A Circuit breaker	1	208	4.5	15,400	4.0	32	⁴ 35
			220	5.0	17,100	4.0	33	⁴ 35
			230	5.5	18,800	4.0	35	⁴ 35
			240	6.0	20,500	4.0	36	40
8 kW 5 lbs.	ECB40-8 (12L87) Terminal Block ECB40-8CB (12L90) 50A Circuit breaker	2	208	6.0	20,500	4.0	41	⁴ 45
			220	6.7	22,900	4.0	43	⁴ 45
			230	7.3	25,100	4.0	45	⁴ 45
			240	8.0	27,300	4.0	47	50
9 kW 5 lbs.	ECB40-9CB (12L91) 60A Circuit breaker	2	208	6.8	23,100	4.0	46	⁴ 50
			220	7.6	25,800	4.0	48	⁴ 50
			230	8.3	28,200	4.0	50	60
			240	9.0	30,700	4.0	52	60

NOTE - Circuit 1 Minimum Circuit Ampacity includes the Blower Motor Full Load Amps.

¹ Electric heater capacity only - does not include additional blower motor heat capacity.

² Amps shown are for blower motor only.

³ Refer to National or Canadian Electrical Code manual to determine wire, fuse and disconnect size requirements. Use wires suitable for at least 167°F.

⁴ Bold text indicates that the circuit breaker on "CB" circuit breaker models must be replaced with size noted. See Table on Page 6.

⁵ HACR type circuit breaker or fuse.

ELECTRIC HEAT DATA - CBX32MV-024/O30

Model Number	No. of Stages	Volts Input	kW Input	¹ Btuh Input	² Blower Motor Full Load Amps	³ Minimum Circuit Ampacity		⁵ Maximum Overcurrent Protection		Single Point Power Source		
						Ckt 1	Ckt 2	Ckt 1	Ckt 2	³ Minimum Circuit Ampacity	⁵ Maximum Overcurrent Protection	
SINGLE PHASE												
4 kW 4 lbs. ECB40-4 (12L76) Terminal Block ECB40-4CB (12L78) 30A Circuit breaker	1	208	3.0	10,250	4.0	23	---	425	---	---	---	
		220	3.4	11,450	4.0	24	---	425	---	---	---	
		230	3.7	12,550	4.0	25	---	425	---	---	---	
		240	4.0	13,650	4.0	26	---	30	---	---	---	
5 kW 4 lbs. ECB40-5 (12L79) Terminal Block ECB40-5CB (12L88) 35A Circuit breaker	1	208	3.8	12,800	4.0	28	---	430	---	---	---	
		220	4.2	14,300	4.0	29	---	430	---	---	---	
		230	4.6	15,700	4.0	30	---	430	---	---	---	
		240	5.0	17,100	4.0	31	---	35	---	---	---	
6 kW 4 lbs. EB40-6 (12L86) Terminal Block ECB40-6CB (12L89) 40A Circuit breaker	1	208	4.5	15,400	4.0	32	---	435	---	---	---	
		220	5.0	17,100	4.0	33	---	435	---	---	---	
		230	5.5	18,800	4.0	35	---	435	---	---	---	
		240	6.0	20,500	4.0	36	---	40	---	---	---	
8 kW 5 lbs. ECB40-8 (12L87) Terminal Block ECB40-8CB (12L90) 50A Circuit breaker	2	208	6.0	20,500	4.0	41	---	445	---	---	---	
		220	6.7	22,900	4.0	43	---	445	---	---	---	
		230	7.3	25,100	4.0	45	---	445	---	---	---	
		240	8.0	27,300	4.0	47	---	50	---	---	---	
9 kW 5 lbs. ECB40-9CB (12L91) 60A Circuit breaker	2	208	6.8	23,100	4.0	46	---	450	---	---	---	
		220	7.6	25,800	4.0	48	---	450	---	---	---	
		230	8.3	28,200	4.0	50	---	60	---	---	---	
		240	9.0	30,700	4.0	52	---	60	---	---	---	
12.5 kW 10 lbs. ECB40-12.5CB (12L92) (1) 30A and (1) 45A Circuit breaker	2	208	9.4	32,000	4.0	24	38	425	440	62	70	
		220	10.5	35,800	4.0	25	40	425	440	65	70	
		230	11.5	39,200	4.0	26	42	30	45	68	70	
		240	12.5	42,600	4.0	27	44	30	45	71	80	
15 kW 12 lbs. ECB40-15CB (12L93) (1) 35A and (1) 60A Circuit breaker	2	208	11.3	38,400	4.0	28	45	430	445	73	80	
		220	12.6	43,000	4.0	29	48	430	450	77	80	
		230	13.8	47,000	4.0	30	50	430	450	80	80	
		240	15.0	51,200	4.0	31	52	35	60	83	90	

NOTE - Circuit 1 Minimum Circuit Ampacity includes the Blower Motor Full Load Amps.

¹ Electric heater capacity only - does not include additional blower motor heat capacity.

² Amps shown are for blower motor only.

³ Refer to National or Canadian Electrical Code manual to determine wire, fuse and disconnect size requirements. Use wires suitable for at least 167°F.

⁴ Bold text indicates that the circuit breaker on "CB" circuit breaker models must be replaced with size noted. See Table on Page 6.

⁵ HACR type circuit breaker or fuse.

ELECTRIC HEAT DATA - CBX32MV-036

Model Number	No. of Stages	Volts Input	kW Input	1 Btuh Input	2 Blower Motor Full Load Amps	3 Minimum Circuit Ampacity		5 Maximum Overcurrent Protection		Single Point Power Source		
						Ckt 1	Ckt 2	Ckt 1	Ckt 2	3 Minimum Circuit Ampacity	5 Maximum Overcurrent Protection	
SINGLE PHASE												
4 kW 4 lbs.	ECB40-4 (12L76) Terminal Block ECB40-4CB (12L78) 35A Circuit breaker	1	208	3.0	10,250	4.0	23	---	425	---	---	---
			220	3.4	11,450	4.0	24	---	425	---	---	---
			230	3.7	12,550	4.0	25	---	425	---	---	---
			240	4.0	13,650	4.0	26	---	430	---	---	---
5 kW 4 lbs.	ECB40-5 (12L79) Terminal Block ECB40-5CB (12L88) 35A Circuit breaker	1	208	3.8	12,800	4.0	28	---	430	---	---	---
			220	4.2	14,300	4.0	29	---	430	---	---	---
			230	4.6	15,700	4.0	30	---	430	---	---	---
			240	5.0	17,100	4.0	31	---	35	---	---	---
6 kW 4 lbs.	ECB40-6 (12L86) Terminal Block ECB40-6CB (12L89) 40A Circuit breaker	1	208	4.5	15,400	4.0	32	---	435	---	---	---
			220	5.0	17,100	4.0	33	---	435	---	---	---
			230	5.5	18,800	4.0	35	---	435	---	---	---
			240	6.0	20,500	4.0	36	---	40	---	---	---
8 kW 5 lbs.	ECB40-8 (12L87) Terminal Block ECB40-8CB (12L90) 50A Circuit breaker	2	208	6.0	20,500	4.0	41	---	445	---	---	---
			220	6.7	22,900	4.0	43	---	445	---	---	---
			230	7.3	25,100	4.0	45	---	445	---	---	---
			240	8.0	27,300	4.0	47	---	50	---	---	---
9 kW 5 lbs.	ECB40-9CB (12L91) 60A Circuit breaker	2	208	6.8	23,100	4.0	46	---	450	---	---	---
			220	7.6	25,800	4.0	48	---	450	---	---	---
			230	8.3	28,200	4.0	50	---	450	---	---	---
			240	9.0	30,700	4.0	52	---	60	---	---	---
12.5 kW 10 lbs.	ECB40-12.5CB (12L92) (1) 30A and (1) 45A Circuit breaker	2	208	9.4	32,000	4.0	24	38	425	440	62	70
			220	10.5	35,800	4.0	25	40	425	440	65	70
			230	11.5	39,200	4.0	26	42	30	45	68	70
			240	12.5	42,600	4.0	27	44	30	45	71	80
15 kW 12 lbs.	ECB40-15CB (12L93) (1) 35A and (1) 60A Circuit breaker	2	208	11.3	38,400	4.0	28	45	430	445	73	80
			220	12.6	43,000	4.0	29	48	430	450	77	80
			230	13.8	47,000	4.0	30	50	430	450	80	80
			240	15.0	51,200	4.0	31	52	35	60	83	90
20 kW 19 lbs.	ECB40-20CB (12L94) (2) 60A Circuit breaker	2	208	15.0	51,200	4.0	46	50	450	450	95	100
			220	16.8	57,300	4.0	48	53	450	60	101	110
			230	18.4	62,700	4.0	50	55	450	60	105	110
			240	20.0	68,200	4.0	52	57	60	60	109	110
THREE PHASE												
8 kW 5 lbs.	ECB40-8 (12L96) Terminal Block	1	208	6.0	20,500	4.0	26	---	30	---	---	---
			220	6.7	22,900	4.0	27	---	30	---	---	---
			230	7.3	25,100	4.0	28	---	30	---	---	---
			240	8.0	27,300	4.0	28	---	30	---	---	---
10 kW 6 lbs.	ECB40-10 (12L97) Terminal Block	1	208	7.5	25,600	4.0	31	---	35	---	---	---
			220	8.4	28,700	4.0	33	---	35	---	---	---
			230	9.2	31,400	4.0	34	---	35	---	---	---
			240	10.0	34,100	4.0	35	---	40	---	---	---
15 kW 12 lbs.	ECB40-15CB (12L98) 50A Circuit breaker	1	208	11.3	38,400	4.0	44	---	445	---	---	---
			220	12.6	43,000	4.0	46	---	50	---	---	---
			230	13.5	47,000	4.0	48	---	50	---	---	---
			240	15.0	51,200	4.0	50	---	50	---	---	---
20 kW 19 lbs.	ECB40-20CB (12L99) (2) 35A Circuit breaker	2	208	15.0	51,200	4.0	31	26	35	430	57	60
			220	16.8	57,300	4.0	33	28	35	430	61	70
			230	18.4	62,700	4.0	34	29	35	430	63	70
			240	20.0	68,200	4.0	35	30	440	35	65	70

NOTE - Circuit 1 Minimum Circuit Ampacity includes the Blower Motor Full Load Amps.

1 Electric heater capacity only - does not include additional blower motor heat capacity.

2 Amps shown are for blower motor only.

3 Refer to National or Canadian Electrical Code manual to determine wire, fuse and disconnect size requirements. Use wires suitable for at least 167°F.

4 Bold text indicates that the circuit breaker on "CB" circuit breaker models must be replaced with size noted. See Table on Page 6.

5 HACR type circuit breaker or fuse.

ELECTRIC HEAT DATA - CBX32MV-048 AND CBX32MV-060

Model Number	No. of Stages	Volts Input	kW Input	1 Btuh Input	2 Blower Motor Full Load Amps	3 Minimum Circuit Ampacity			5 Maximum Overcurrent Protection			Single Point Power Source		
						Ckt 1	Ckt 2	Ckt 3	Ckt 1	Ckt 2	Ckt 3	3 Minimum Circuit Ampacity	5 Maximum Overcurrent Protection	
SINGLE PHASE														
4 kW 4 lbs. ECB40-4 (12L76) Terminal Block	1	208	3.0	10,250	7.4	27	---	---	---	4 30	---	---	---	---
		220	3.4	11,450	7.4	28	---	---	---	4 30	---	---	---	---
		230	3.7	12,550	7.4	29	---	---	---	4 30	---	---	---	---
		240	4.0	13,650	7.4	30	---	---	---	4 30	---	---	---	---
5 kW 4 lbs. ECB40-5 (12L79) Terminal Block	1	208	3.8	12,800	7.4	32	---	---	---	35	---	---	---	---
		220	4.2	14,300	7.4	33	---	---	---	35	---	---	---	---
		230	4.6	15,700	7.4	34	---	---	---	35	---	---	---	---
		240	5.0	17,100	7.4	35	---	---	---	4 40	---	---	---	---
6 kW 4 lbs. ECB40-6 (12L86) Terminal Block	1	208	4.5	15,400	7.4	36	---	---	---	40	---	---	---	---
		220	5.0	17,100	7.4	38	---	---	---	40	---	---	---	---
		230	5.5	18,800	7.4	39	---	---	---	40	---	---	---	---
		240	6.0	20,500	7.4	41	---	---	---	4 45	---	---	---	---
8 kW 5 lbs. ECB40-8 (12L87) Terminal Block	2	208	6.0	20,500	7.4	45	---	---	---	50	---	---	---	---
		220	6.7	22,900	7.4	47	---	---	---	50	---	---	---	---
		230	7.3	25,100	7.4	49	---	---	---	50	---	---	---	---
		240	8.0	27,300	7.4	51	---	---	---	4 60	---	---	---	---
9 kW 5 lbs. ECB40-9CB (12L91) 60A Circuit breaker	2	208	6.8	23,100	7.4	50	---	---	---	60	---	---	---	---
		220	7.6	25,800	7.4	52	---	---	---	60	---	---	---	---
		230	8.3	28,200	7.4	54	---	---	---	60	---	---	---	---
		240	9.0	30,700	7.4	56	---	---	---	60	---	---	---	---
12.5 kW 10 lbs. ECB40-12.5CB (12L92) (1) 30A and (1) 45A Circuit breaker	2	208	9.4	32,000	7.4	28	38	---	30	4 40	---	66	70	
		220	10.5	35,800	7.4	29	40	---	30	4 40	---	69	70	
		230	11.5	39,200	7.4	30	42	---	30	45	---	72	80	
		240	12.5	42,600	7.4	31	44	---	4 35	45	---	75	80	
15 kW 12 lbs. ECB40-15CB (12L93) (1) 35A and (1) 60A Circuit breaker	2	208	11.3	38,400	7.4	32	45	---	35	4 45	---	77	80	
		220	12.6	43,000	7.4	33	48	---	35	4 50	---	81	90	
		230	13.5	47,000	7.4	34	50	---	35	4 50	---	84	90	
		240	15.0	51,200	7.4	35	52	---	4 40	60	---	88	90	
20 kW 19 lbs. ECB40-20CB (12L94) (2) 60A Circuit breaker	2	208	15.0	51,200	7.4	50	50	---	4 50	4 50	---	100	100	
		220	16.8	57,300	7.4	52	53	---	60	60	---	105	125	
		230	18.4	62,700	7.4	54	55	---	60	60	---	109	125	
		240	20.0	68,200	7.4	56	57	---	60	60	---	113	125	
25 kW 19 lbs. ECB40-25CB (12L95) (1) 60A and (2) 45A Circuit breaker	3	208	18.8	64,100	7.4	47	38	38	4 50	4 40	4 40	122	125	
		220	21.0	71,700	7.4	49	40	40	4 50	4 40	4 40	129	150	
		230	23.0	78,300	7.4	51	42	42	60	45	45	135	150	
		240	25.0	85,300	7.4	53	44	44	60	45	45	141	150	
THREE PHASE														
8 kW 5 lbs. ECB40-8 (12L96) Terminal block	1	208	6.0	20,500	7.4	30	---	---	---	35	---	---	---	---
		220	6.7	22,900	7.4	31	---	---	---	35	---	---	---	---
		230	7.3	25,100	7.4	32	---	---	---	35	---	---	---	---
		240	8.0	27,300	7.4	33	---	---	---	35	---	---	---	---
10 kW 6 lbs. ECB40-10 (12L97) Terminal block	1	208	7.5	25,600	7.4	35	---	---	---	40	---	---	---	---
		220	8.4	28,700	7.4	37	---	---	---	40	---	---	---	---
		230	9.2	31,400	7.4	38	---	---	---	40	---	---	---	---
		240	10.0	34,100	7.4	39	---	---	---	40	---	---	---	---
15 kW 12 lbs. ECB40-15CB (12L98) 50A Circuit breaker	1	208	11.3	38,400	7.4	48	---	---	---	50	---	---	---	---
		220	12.6	43,000	7.4	51	---	---	---	4 60	---	---	---	---
		230	13.5	47,000	7.4	52	---	---	---	4 60	---	---	---	---
		240	15.0	51,200	7.4	54	---	---	---	4 60	---	---	---	---
20 kW 19 lbs. ECB40-20CB (12L99) (2) 35A Circuit breaker	2	208	15.0	51,200	7.4	35	26	---	4 40	4 30	---	62	70	
		220	16.8	57,300	7.4	37	28	---	4 40	4 30	---	65	70	
		230	18.4	62,700	7.4	38	29	---	4 40	4 30	---	67	70	
		240	20.0	68,200	7.4	39	30	---	4 40	35	---	70	70	
25 kW 19 lbs. ECB40-25CB (12M75) (1) 50A and (1) 40A Circuit breaker	2	208	18.8	64,100	7.4	42	33	---	4 45	4 35	---	75	80	
		220	21.0	71,700	7.4	44	34	---	4 45	4 35	---	78	80	
		230	23.0	78,300	7.4	45	36	---	50	40	---	81	90	
		240	25.0	85,300	7.4	47	38	---	50	40	---	84	90	

NOTE - Circuit 1 Minimum Circuit Ampacity includes the Blower Motor Full Load Amps.

1 Electric heater capacity only - does not include additional blower motor heat capacity.

2 Amps shown are for blower motor only.

3 Refer to National or Canadian Electrical Code manual to determine wire, fuse and disconnect size requirements. Use wires suitable for at least 167°F.

4 Bold text indicates that the circuit breaker on "CB" circuit breaker models must be replaced with size noted. See Table on Page 6.

5 HACR type circuit breaker or fuse.

ELECTRIC HEAT DATA - CBX32MV-068

Model Number	No. of Stages	Volts Input	kW Input	1 Btuh Input	2 Blower Motor Full Load Amps	3 Minimum Circuit Ampacity			5 Maximum Overcurrent Protection			Single Point Power Source			
						Ckt 1	Ckt 2	Ckt 3	Ckt 1	Ckt 2	Ckt 3	3 Minimum Circuit Ampacity	5 Maximum Overcurrent Protection		
SINGLE PHASE															
5 kW 4 lbs.	ECB40-5 (12L79) Terminal Block ECB40-5CB (12L88) 35A Circuit breaker	1	208	3.8	12,800	7.4	32	---	---	35	---	---	---	---	---
			220	4.2	14,300	7.4	33	---	---	35	---	---	---	---	---
			230	4.6	15,700	7.4	34	---	---	35	---	---	---	---	---
			240	5.0	17,100	7.4	35	---	---	⁴ 40	---	---	---	---	---
6 kW 4 lbs.	ECB40-6 (12L86) Terminal Block ECB40-6CB (12L89) 40A Circuit breaker	1	208	4.5	15,400	7.4	36	---	---	40	---	---	---	---	---
			220	5.0	17,100	7.4	38	---	---	40	---	---	---	---	
			230	5.5	18,800	7.4	39	---	---	40	---	---	---	---	
			240	6.0	20,500	7.4	41	---	---	⁴ 45	---	---	---	---	
8 kW 5 lbs.	ECB40-8 (12L87) Terminal Block ECB40-8CB (12L90) 50A Circuit breaker	2	208	6.0	20,500	7.4	45	---	---	50	---	---	---	---	---
			220	6.7	22,900	7.4	47	---	---	50	---	---	---	---	
			230	7.3	25,100	7.4	49	---	---	50	---	---	---	---	
			240	8.0	27,300	7.4	51	---	---	⁴ 60	---	---	---	---	
9 kW 5 lbs.	ECB40-9CB (12L91) 60A Circuit breaker	2	208	6.8	23,100	7.4	50	---	---	60	---	---	---	---	---
			220	7.6	25,800	7.4	52	---	---	60	---	---	---	---	
			230	8.3	28,200	7.4	54	---	---	60	---	---	---	---	
			240	9.0	30,700	7.4	56	---	---	60	---	---	---	---	
12.5 kW 10 lbs.	ECB40-12.5CB (12L92) (1) 30A and (1) 45A Circuit breaker	2	208	9.4	32,000	7.4	28	38	---	30	⁴ 40	---	66	70	
			220	10.5	35,800	7.4	29	40	---	30	⁴ 40	---	69	70	
			230	11.5	39,200	7.4	30	42	---	30	45	---	72	80	
			240	12.5	42,600	7.4	31	44	---	⁴ 35	45	---	75	80	
15 kW 12 lbs.	ECB40-15CB (12L93) (1) 35A and (1) 60A Circuit breaker	2	208	11.3	38,400	7.4	32	45	---	35	⁴ 45	---	77	80	
			220	12.6	43,000	7.4	33	48	---	35	⁴ 50	---	81	90	
			230	13.5	47,000	7.4	34	50	---	35	⁴ 50	---	84	90	
			240	15.0	51,200	7.4	35	52	---	⁴ 40	60	---	88	90	
20 kW 19 lbs.	ECB40-20CB (12L94) (2) 60A Circuit breaker	2	208	15.0	51,200	7.4	50	50	---	⁴ 50	⁴ 50	---	100	100	
			220	16.8	57,300	7.4	52	53	---	60	60	---	105	125	
			230	18.4	62,700	7.4	54	55	---	60	60	---	109	125	
			240	20.0	68,200	7.4	56	57	---	60	60	---	113	125	
25 kW 19 lbs.	ECB40-25CB (12L95) (1) 60A and (2) 45A Circuit breaker	3	208	18.8	64,100	7.4	47	38	38	⁴ 50	⁴ 40	⁴ 40	122	125	
			220	21.0	71,700	7.4	49	40	40	⁴ 50	⁴ 40	⁴ 40	129	150	
			230	23.0	78,300	7.4	51	42	42	60	45	45	135	150	
			240	25.0	85,300	7.4	53	44	44	60	45	45	141	150	
THREE PHASE															
8 kW 5 lbs.	ECB40-8 (12L96) Terminal block	1	208	6.0	20,500	7.4	30	---	---	35	---	---	---	---	---
			220	6.7	22,900	7.4	31	---	---	35	---	---	---	---	
			230	7.3	25,100	7.4	32	---	---	35	---	---	---	---	
			240	8.0	27,300	7.4	33	---	---	35	---	---	---	---	
10 kW 6 lbs.	ECB40-10 (12L97) Terminal block	1	208	7.5	25,600	7.4	35	---	---	40	---	---	---	---	
			220	8.4	28,700	7.4	37	---	---	40	---	---	---	---	
			230	9.2	31,400	7.4	38	---	---	40	---	---	---	---	
			240	10.0	34,100	7.4	39	---	---	40	---	---	---	---	
15 kW 12 lbs.	ECB40-15CB (12L98) 50A Circuit breaker	1	208	11.3	38,400	7.4	48	---	---	50	---	---	---	---	
			220	12.6	43,000	7.4	51	---	---	⁴ 60	---	---	---	---	
			230	13.5	47,000	7.4	52	---	---	⁴ 60	---	---	---	---	
			240	15.0	51,200	7.4	54	---	---	⁴ 60	---	---	---	---	
20 kW 19 lbs.	ECB40-20CB (12L99) (2) 35A Circuit breaker	2	208	15.0	51,200	7.4	35	26	---	⁴ 40	⁴ 30	---	62	70	
			220	16.8	57,300	7.4	37	28	---	⁴ 40	⁴ 30	---	65	70	
			230	18.4	62,700	7.4	38	29	---	⁴ 40	⁴ 30	---	67	70	
			240	20.0	68,200	7.4	39	30	---	⁴ 40	35	---	70	70	
25 kW 19 lbs.	ECB40-25CB (12M75) (1) 50A and (1) 40A Circuit breaker	2	208	18.8	64,100	7.4	42	33	---	⁴ 45	⁴ 35	---	75	80	
			220	21.0	71,700	7.4	44	34	---	⁴ 45	⁴ 35	---	78	80	
			230	23.0	78,300	7.4	45	36	---	50	40	---	81	90	
			240	25.0	85,300	7.4	47	38	---	50	40	---	84	90	

NOTE - Circuit 1 Minimum Circuit Ampacity includes the Blower Motor Full Load Amps.

¹ Electric heater capacity only - does not include additional blower motor heat capacity.

² Amps shown are for blower motor only.

³ Refer to National or Canadian Electrical Code manual to determine wire, fuse and disconnect size requirements. Use wires suitable for at least 167°F.

⁴ Bold text indicates that the circuit breaker on "CB" circuit breaker models must be replaced with size noted. See Table on Page 6.

⁵ HACR type circuit breaker or fuse.

DIMENSIONS - INCHES (MM) UPFLOW

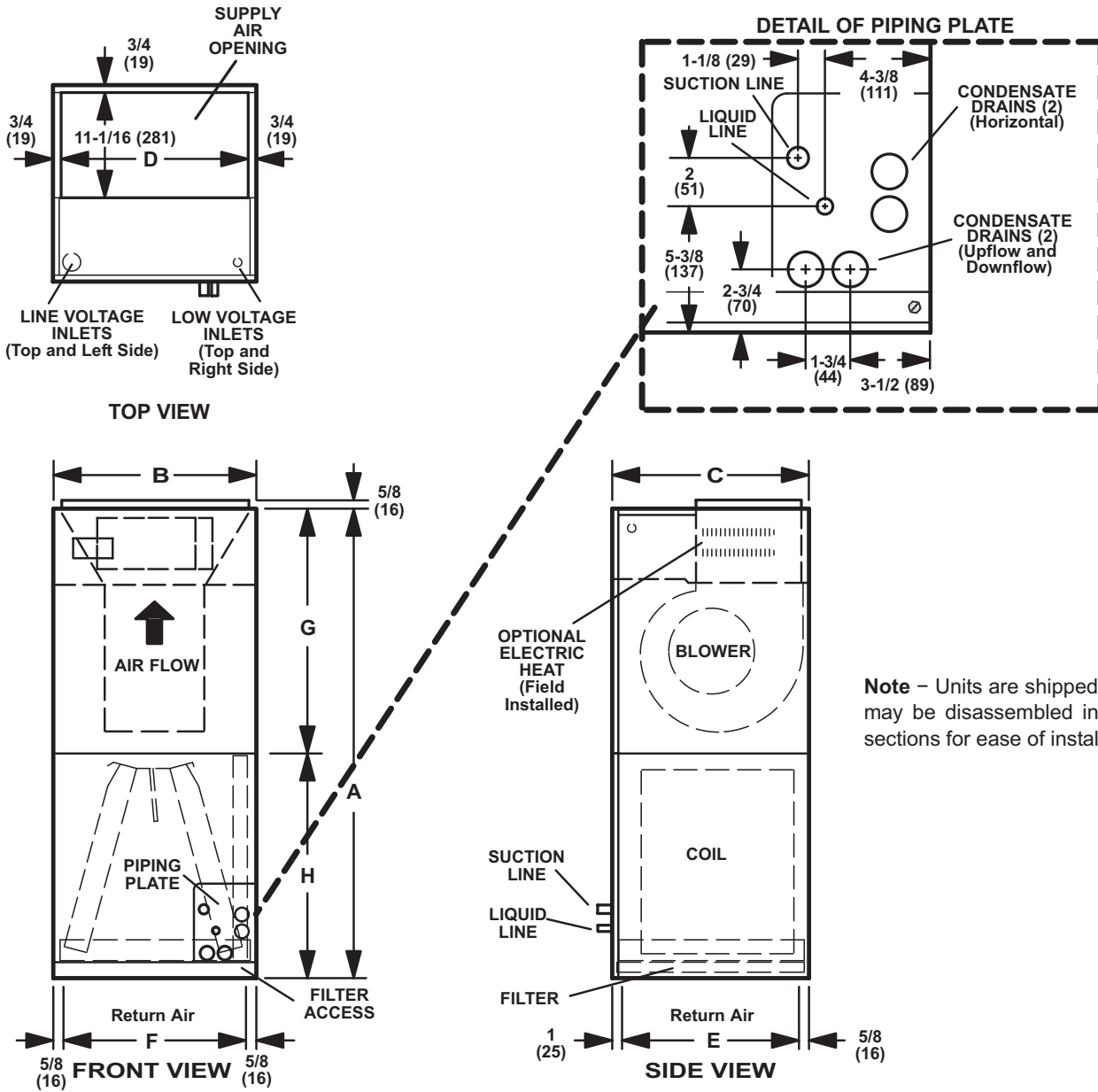

Model No.	CBX32MV-018/024		CBX32MV-024/030		CX32MV-036		CBX32MV-048 CBX32MV-060		CBX32MV-068	
	inch	mm	inch	mm	inch	mm	inch	mm	inch	mm
A	45-1/4	1149	49-1/4	1251	51	1295	58-1/2	1486	65	1651
B	16-1/4	413	21-1/4	540	21-1/4	540	21-1/4	540	21-1/4	540
C	20-5/8	524	20-5/8	524	22-5/8	575	24-7/8	625	26-5/8	675
D	14-3/4	375	19-3/4	502	19-3/4	502	19-3/4	502	19-3/4	502
E	19	483	19	483	21	533	23	584	25	635
F	15	381	20	508	20	508	20	508	20	508
G	24-5/8	625	24-5/8	625	26-3/4	640	27-7/8	708	32-3/8	822
H	20-5/8	524	24-5/8	625	24-5/8	625	30-5/8	778	32-5/8	829

DIMENSIONS - INCHES (MM) DOWNFLOW

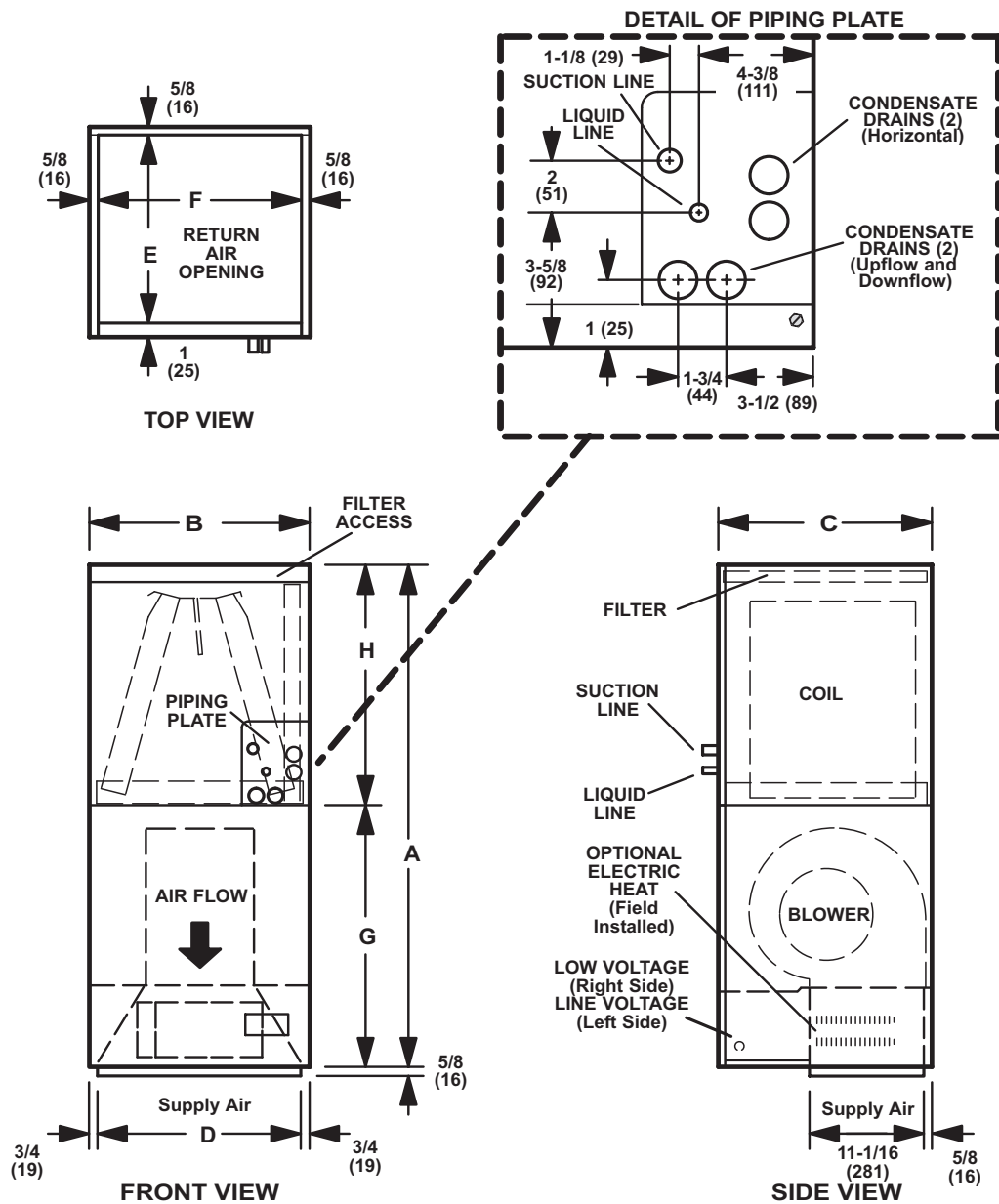

NOTE - Units are shipped in one piece but may be disassembled into two separate sections for ease of installation.

Model No.	CBX32MV-018/024		CBX32MV-024/030		CX32MV-036		CBX32MV-048 CBX32MV-060		CBX32MV-068	
	inch	mm	inch	mm	inch	mm	inch	mm	inch	mm
A	45-1/4	1149	49-1/4	1251	51	1295	58-1/2	1486	65	1651
B	16-1/4	413	21-1/4	540	21-1/4	540	21-1/4	540	21-1/4	540
C	20-5/8	524	20-5/8	524	22-5/8	575	24-7/8	625	26-5/8	675
D	14-3/4	375	19-3/4	502	19-3/4	502	19-3/4	502	19-3/4	502
E	19	483	19	483	21	533	23	584	25	635
F	15	381	20	508	20	508	20	508	20	508
G	24-5/8	625	24-5/8	625	26-3/4	640	27-7/8	708	32-3/8	822
H	20-5/8	524	24-5/8	625	24-5/8	625	30-5/8	778	32-5/8	829

DIMENSIONS - INCHES (MM) HORIZONTAL

RIGHT-HAND AIR DISCHARGE

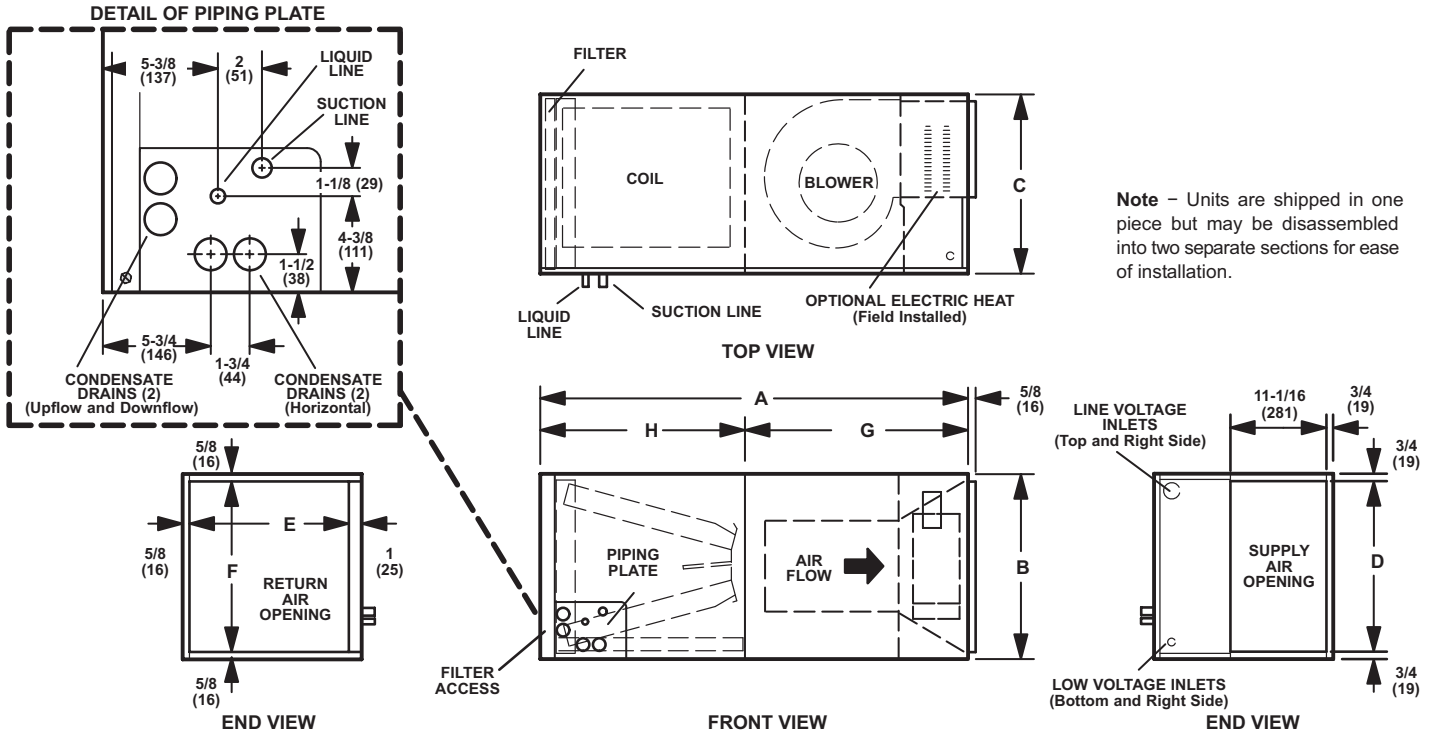

LEFT-HAND AIR DISCHARGE

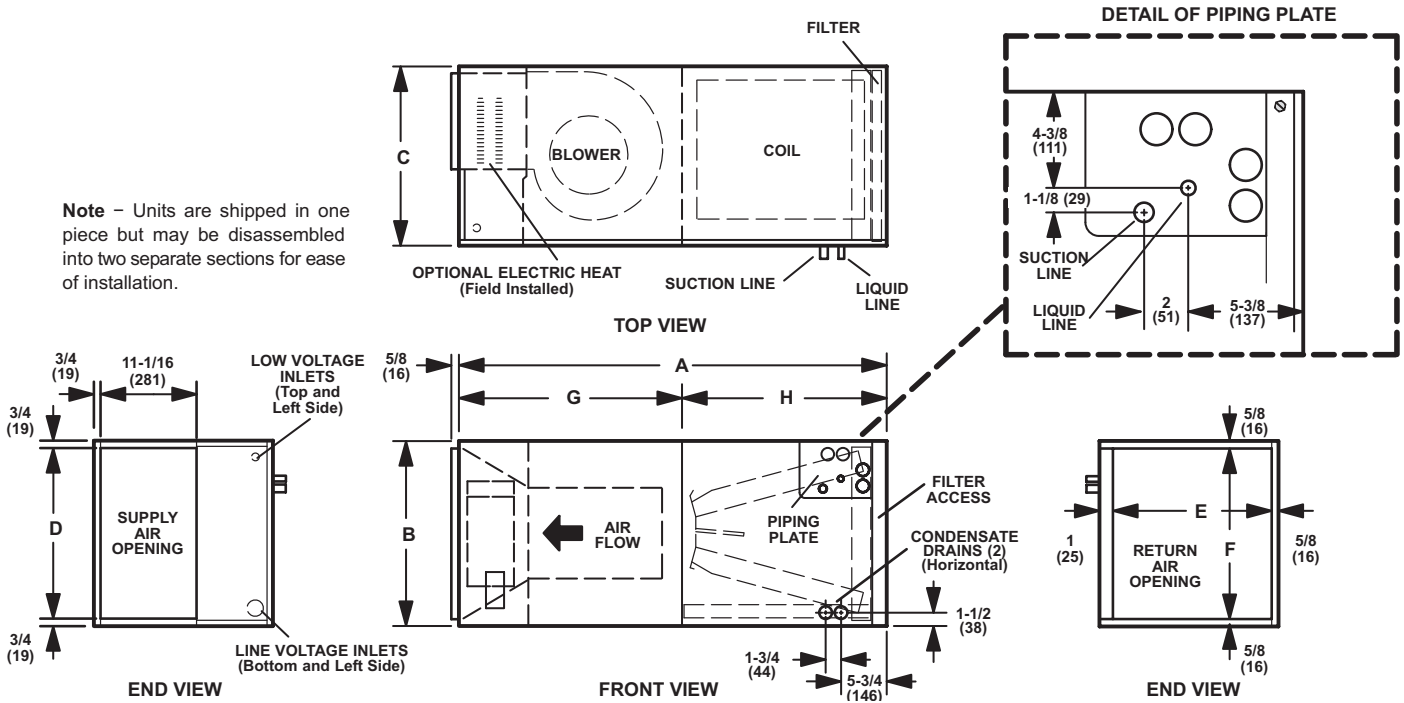

Model No.	CBX32MV-018/024		CBX32MV-024/030		CX32MV-036		CBX32MV-048 CBX32MV-060		CBX32MV-068	
	inch	mm	inch	mm	inch	mm	inch	mm	inch	mm
A	45-1/4	1149	49-1/4	1251	51	1295	58-1/2	1486	65	1651
B	16-1/4	413	21-1/4	540	21-1/4	540	21-1/4	540	21-1/4	540
C	20-5/8	524	20-5/8	524	22-5/8	575	24-7/8	625	26-5/8	675
D	14-3/4	375	19-3/4	502	19-3/4	502	19-3/4	502	19-3/4	502
E	19	483	19	483	21	533	23	584	25	635
F	15	381	20	508	20	508	20	508	20	508
G	24-5/8	625	24-5/8	625	26-3/4	640	27-7/8	708	32-3/8	822
H	20-5/8	524	24-5/8	625	24-5/8	625	30-5/8	778	32-5/8	829

DIMENSIONS - INCHES (MM)

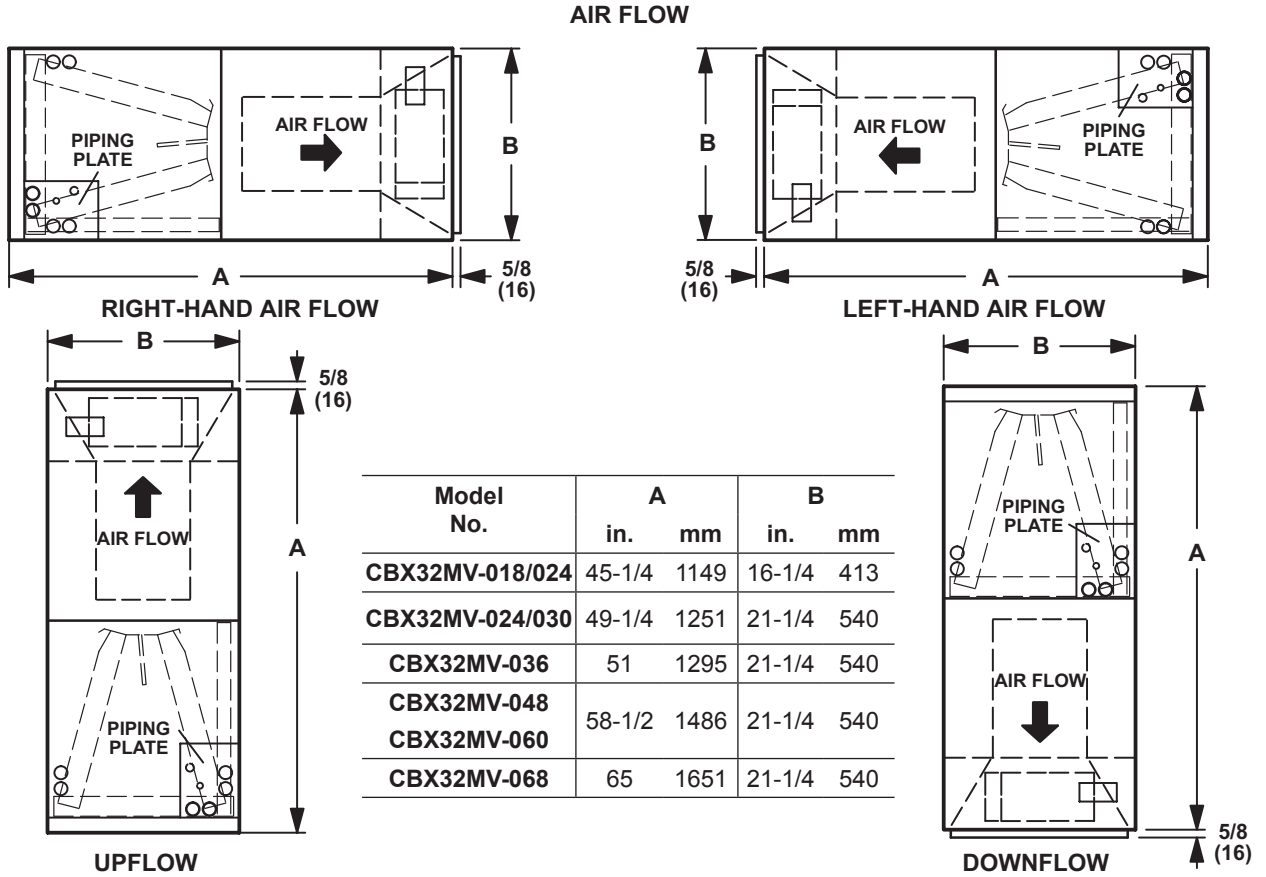

SIDE RETURN UNIT STAND (Upflow Only)

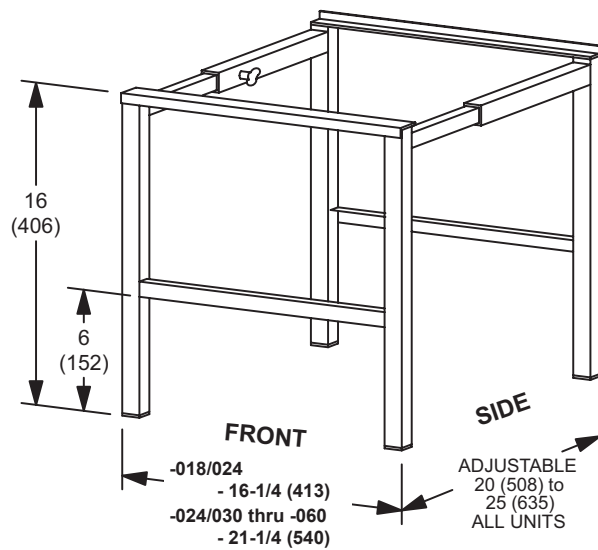

DIMENSIONS - INCHES (MM)

DOWNFLOW COMBUSTIBLE FLOORING BASE

Catalog No. - 34J72

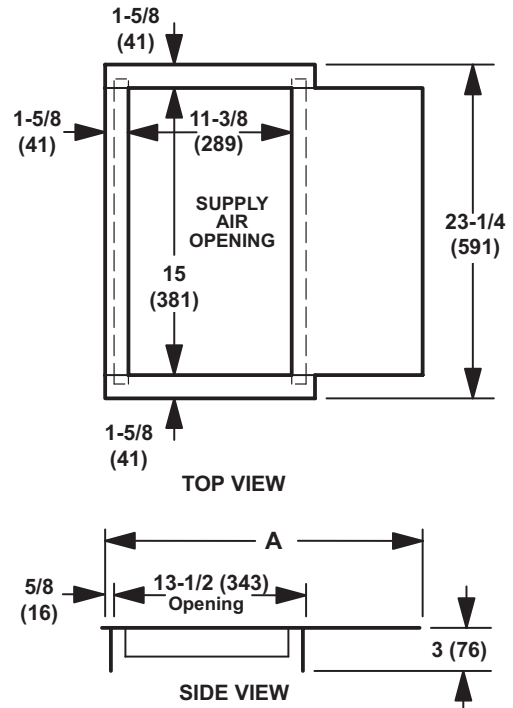
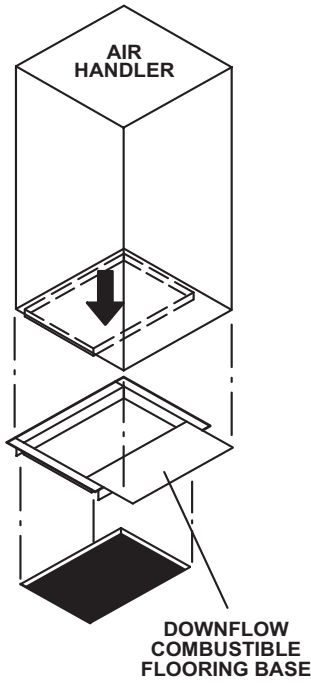

Catalog No. - 44K15

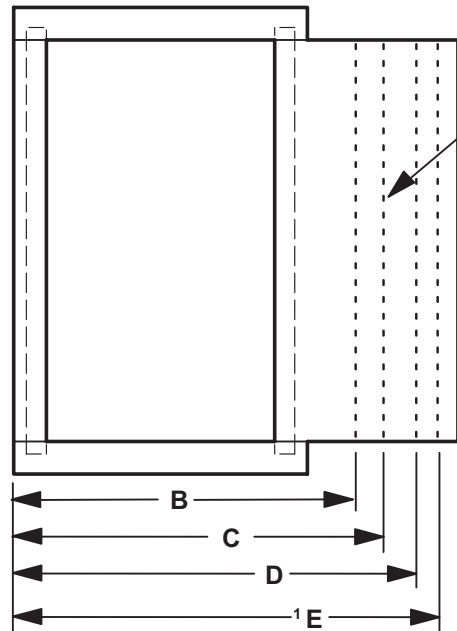
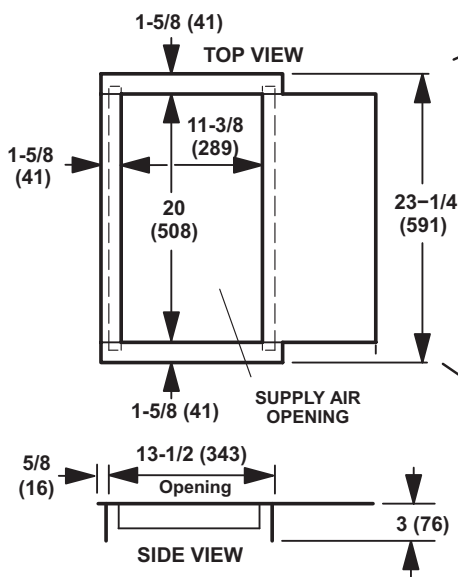

Break off extended width at pre-perforated line to fit specific air handler application.
NOTE - Width of base includes an additional 2 in. (51 mm) for air handler positioning adjustment.

¹ No modification required.

Model No.	CBX32MV-018/024		CBX32MV-024/030		CBX32MV-036		CBX32MV-048 CBX32MV-060		CBX32MV-068	
	in.	mm	in.	mm	in.	mm	in.	mm	in.	mm
A	22-1/8	562	---	---	---	---	---	---	---	---
B	---	---	22-5/8	575	---	---	---	---	---	---
C	---	---	---	---	24-5/8	625	---	---	---	---
D	---	---	---	---	---	---	26-5/8	676	---	---
E	---	---	---	---	---	---	---	---	28-5/8	727

REVISIONS

Sections	Description of Change
Electric Heat Data	Changed ECB40-8 (12L87) and ECB40-8CB (12L90) from 1 stage to 2.



Visit us at www.lennox.com

For the latest technical information, www.LennoxPros.com

Contact us at 1-800-4-LENNOX

NOTE - Due to Lennox' ongoing commitment to quality, Specifications, Ratings and Dimensions subject to change without notice and without incurring liability. Improper installation, adjustment, alteration, service or maintenance can cause property damage or personal injury. Installation and service must be performed by a qualified installer and servicing agency.

©2018 Lennox Industries, Inc.