



**RESIDENTIAL  
PRODUCT SPECIFICATIONS**

Bulletin No. 210856  
April 2021  
Supersedes December 2020



**ELITE®  
SERIES**

**AFUE - 96%**  
**Input - 44,000 to 88,000 Btuh**  
**Nominal Add-on Cooling - 1.5 to 4 Tons**

**MODEL NUMBER IDENTIFICATION**

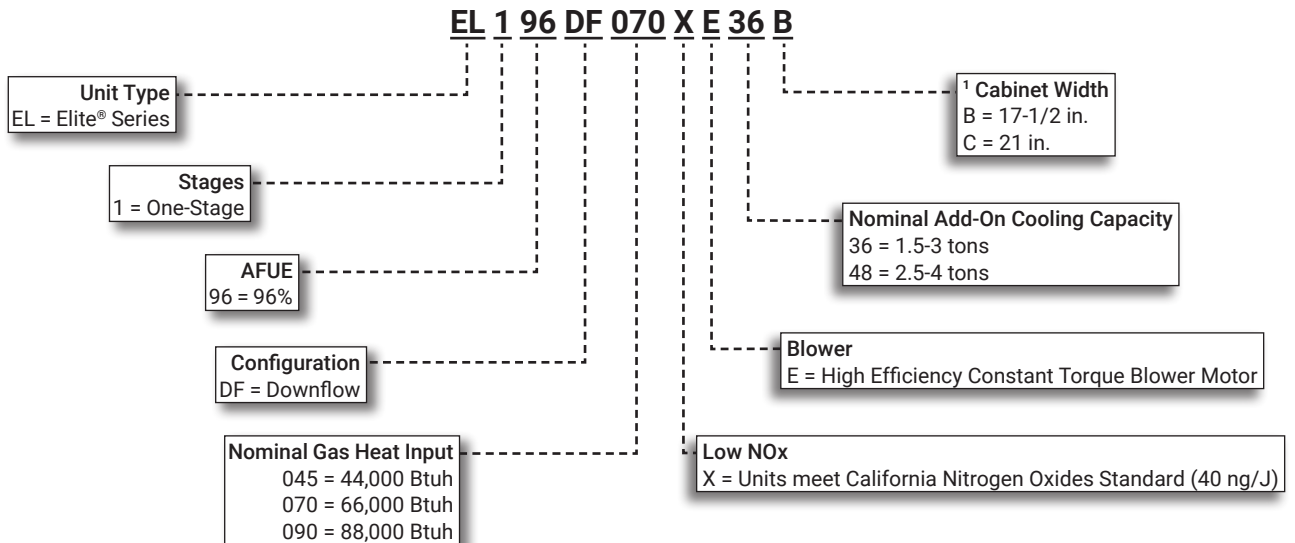

<sup>1</sup> Downflow indoor coils with the same letter designation will physically match the furnace **supply air opening**.

## FEATURE HIGHLIGHTS

1. Lennox Duralok Plus™ Heat Exchanger
2. Secondary Heat Exchanger
3. Inshot Burners
4. Gas Control Valve
5. Combustion Air Inducer
6. Direct Vent / Non-Direct Vent Sealed Combustion System
7. SureLight® Integrated Furnace Control
8. Power Saver™ Constant Torque Blower Motor
9. Insulated Cabinet
10. Safety Interlock Switch
11. Gas Piping And Electrical Inlets

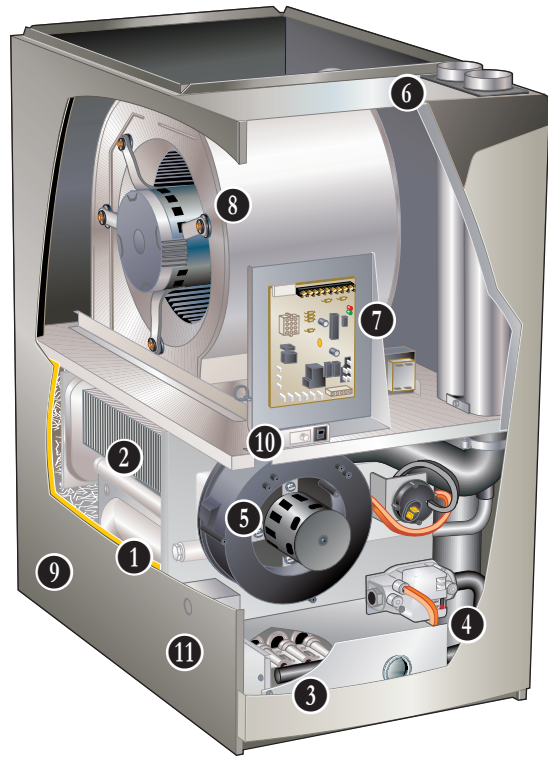

## CONTENTS

Approvals And Warranty . . . . .	3
Blower Data . . . . .	12
Dimensions . . . . .	13
- Unit . . . . .	13
- Optional Accessories . . . . .	14
- Furnace/Coil Combined Dimensions . . . . .	14
- Optional Accessories - Venting. . . . .	15
Features . . . . .	3
Gas Heat Accessories . . . . .	9
High Altitude Derate . . . . .	10
Installation Clearances . . . . .	7
Model Number Identification. . . . .	1
Optional Accessories - Order Separately . . . . .	9
Specifications . . . . .	8
Vent Lengths . . . . .	11

## APPROVALS AND WARRANTY

### APPROVALS

- AHRI Certified
- CSA International Certified
- Tested and rated according to US DOE test procedures and FTC labeling regulations
- Units are approved for installations from 0 - 4500 ft.
- ENERGY STAR® certified units are designed to use less energy, help save money on utility bills, and help protect the environment
- ISO 9001 Registered Manufacturing Quality System
- Blower data from unit tests conducted in Lennox Laboratory air test chamber

### **California Only**

- These furnaces **do not meet** the South Coast Air Quality Management District (SCAQMD) Rule 1111 and San Joaquin Valley Air Pollution Control District (SJVAPCD) Rule 4905 NOx emission limit (14 ng/J) and cannot be installed within the SCAQMD and SJVAPCD areas
- These furnaces are approved by the California Energy Commission and meets California Nitrogen Oxides Standard (NOx) limits of 40 ng/J

### WARRANTY

- Duralok Plus™ Aluminized Steel Heat Exchanger:
  - Limited lifetime (twenty year transferable) in residential applications
  - Limited ten years in non-residential applications
- All other covered components:
  - Limited five years in residential installations
  - Limited one year in non-residential installations

**NOTE** - Refer to Lennox Equipment Limited Warranty certificate included with unit for specific details.

## FEATURES

### APPLICATIONS

- Input capacities of 44,000, 66,000 and 88,000 Btuh
- Energy efficiency (AFUE) - 96%
- Compact cabinet for downflow applications without any internal modifications to the unit
- Lennox add-on indoor coils, high-efficiency air cleaners and humidifiers can easily be added to furnace
- Shipped factory assembled with controls installed and wired
- Factory test operated to ensure proper operation

### HEATING SYSTEM

- 1 **Lennox Duralok Plus™ Heat Exchanger Assembly**
  - Lennox developed heat exchanger assembly consists of primary heat exchanger and secondary condenser coil assembly
  - Main multi-pass crimped seam design clamshell type heat exchanger
  - Constructed of heavy-gauge, aluminized steel
  - Designed for normal expansion and contraction with maximum efficiency and minimum resistance to air flow

- 2
  - Secondary heat exchanger condenser coil constructed of aluminum fins fitted to stainless steel tubes
  - Coil is factory tested for leaks
  - Condensate drain header box assembly located on front of coil
  - Compact size permits low overall design of furnace cabinet
  - Laboratory life cycle tested in excess of industry standards

### **Lennox Designed Header Box**

- Header box on end of condenser coil collects flue condensate for disposal through condensate drains
- The drains are located on each side of the cabinet for easy field installation of condensate drain trap
- Only one drain is used, the other drain is sealed
- Condensate drain trap is included with unit for field installation

## FEATURES

### HEATING SYSTEM (continued)

#### Lennox Designed Flue Condensate Trap Assembly

- Condensate trap assembly is mounted outside the conditioned air stream
- Assembly can be mounted on either side of cabinet
- See Installation Instructions
- 90° street elbow furnished for ease of drain trap installation
- Drain connection can be made with field provided PVC pipe, PVC coupling, or vinyl tubing with hose clamp
- Drain cap on trap allows easy cleaning and winterizing

#### 3 Inshot Burners

- Aluminized steel inshot burners provide efficient, trouble-free operation
- Burner venturi mixes air and gas in correct proportion for proper combustion
- Burner assembly is removable from the unit as a single component for ease of service

#### SureLight® Hot Surface Ignitor

- Tough, reliable, long-life, trouble-free performance
- Silicon nitride ignitor
- Cemented to steatite block for protection against current leakage
- Ignition leads are constructed of nickel plated copper and are enclosed in high temperature Teflon® insulation for dependable operation

#### 4 Gas Control Valve

- 24 volt redundant combination gas control valve combines manual shut off switch (On-Off), automatic electric valve (dual) and gas pressure regulation into a compact combination control

#### 5 Combustion Air Inducer

- Shaded pole heavy duty blower prepurges heat exchanger and safely vents flue products
- Operates only during heating cycle
- Pressure switch proves combustion air inducer operation before allowing gas valve to open

#### Flame Rollout Switches (2)

- Factory installed in burner box
- Switch provides protection from abnormal operating conditions
- Manual reset

#### Limit Control

- Primary limit is accurately located on vestibule panel
- Automatic reset

### Optional Accessories

#### High Altitude Orifice Kits

- Required on all units for proper unit operation at altitudes from 7501 to 10,000 ft.
- Available for natural gas and LPG/propane

#### High Altitude Pressure Switch Kit

- Required for proper unit operation on installations above 4500 ft.

#### Natural Gas to LPG/Propane Conversion Kit

- Required for field changeover from natural gas to LPG/Propane

#### LPG/Propane to Natural Gas Conversion Kit

- Required for field changeover from LPG/Propane to natural gas

#### Muffler (US Only)

- Significantly reduces outdoor operating sound levels
- Installed vertically in the exhaust piping
- See Optional Accessory Dimension Drawing

### DIRECT VENT / NON-DIRECT VENT SEALED COMBUSTION SYSTEM

- 6 • Furnace features a "sealed combustion" system and can be installed in either Direct Vent or Non-Direct applications
- In Direct Vent applications, combustion air is supplied from outdoors and flue gases are discharged outdoors
- In Non-Direct Vent applications, combustion air is supplied from indoors and flue gases are discharged outdoors

**NOTE** - Lennox has approved the use of DuraVent® PolyPro® and Centrotherm InnoFlue® manufactured vent pipe and terminations as an alternative to PVC vent pipe. Must be ordered separately.

- Tested and listed to the ULC S636 standard in Canada
- The polypropylene venting system must follow the uninsulated and unconditioned space vent lengths listed in the table on Page 11
- Refer to the Installation Instructions for additional details

#### Flue Coupling

- Assists with exhaust flue piping connection and servicing
- Includes flexible one 2 inch rubber coupling and two adjustable bands
- Approved for all Lennox 90% furnaces

## FEATURES

### **DIRECT VENT / NON-DIRECT VENT SEALED COMBUSTION SYSTEM (continued)**

#### **Termination Kits**

- Facilitates installation of combustion air intake pipe and flue exhaust pipe
- Refer to venting table in this bulletin to determine pipe size needed and proper termination kit required
- Certain Termination Kits are certified to ULC S636 standard for use in Canada only
- See Optional Accessories table and dimension drawings

#### **Concentric - Direct Vent Applications**

- 2 or 3 inch kit contains concentric termination assembly, reducer bushing and 45 degree elbow
- 2 inch kit for -045-070 models contains an outdoor exhaust accelerator
- Kit requires single hole penetration of roof or wall for installation
- Roof Termination Flashing Kit is available for use with 2 inch Kits
- CSA certified

#### **Flush-Mount**

- Kit contains flush-mount termination, accelerator, mounting template and hardware
- Kit may be used with 2, 2-1/2 or 3 in. pipe

#### **Wall Assembly**

##### **Close Couple (US Only) - Direct Vent Applications**

- 2 or 3 inch kit consists of close-couple, side-by-side PVC piping with galvanized steel wall cover plate for sealing and isolating piping penetration of the wall
- Piping spacing and length is sized for proper wall installations
- CSA certified

##### **Close Couple WTK (Canada Only) - Direct Vent Applications**

- 2 or 3 inch kit contains one insulated faceplate, one insulated exhaust pipe, elbow and fittings. Certified to ULC S636 standard

**NOTE** - Maintain a maximum of 6 inches between the inlet and outlet openings in the installation of the pipes.

#### **Roof Termination Flashing Kit**

- For vertical venting through a roof
- 2 or 3 inch kit contains two neoprene rubber roof flashings
- Vent pipe and insulation not furnished
- Flashing Kit can also be used with Concentric Vent Termination Kits used in vertical venting rooftop applications

## **CONTROLS**

### **7 SureLight® Integrated Furnace Control**

- Contains all necessary controls and relays to operate furnace
- Combustion air inducer is operated by the integrated furnace control. Prior to ignition, a pre-purge cycle for 15 seconds is initiated
- After the main burners are turned off, a post-purge cycle for 5 seconds is run
- Flame sensor assures safe and reliable operation
- Should loss of flame occur, the integrated furnace control will initiate 4 re-attempts at ignition before locking out unit operation for 60 minutes
- Watchguard type circuit automatically resets ignition controls after one hour of continuous thermostat demand after unit lockout, eliminating nuisance calls for service
- Fan control consists of adjustable blower timed-off delay (60, 90, 120, 180 seconds - factory setting 90 seconds) and fixed blower timed-on delay (30 seconds heating, 2 seconds cooling)
- For air-conditioning applications, blower is automatically energized on thermostat demand for cooling
- Two accessory terminals furnished for additional power supply requirements for 120 volt (less than 1 amp) power humidifiers and powered air cleaners
- One additional terminal is furnished for power supply requirements for 24V (less than 0.5 amp) low voltage accessories
- Ignition control has a single red LED to indicate status and as an aid in troubleshooting
- Last ten codes are stored in non-volatile memory (accessible by recall button on control) for servicing

#### **24 Volt Transformer**

- Furnished and factory installed in control box
- \40VA transformer has circuit breaker wired in series

#### **Field Wiring Make-Up Box**

- Furnished for line voltage wiring
- Factory installed internally on left side of furnace
- May be installed internally or externally on either side of furnace

## FEATURES

### CONTROLS (continued)

#### Optional Accessories

##### Blower Relay Kit

(For Use With Two-Stage Outdoor Units)

- Allows furnace blower speed changes when matched with two-stage air conditioners or heat pumps

##### iComfort® E30 Smart Wi-Fi Thermostat

- Wi-Fi enabled, electronic 7-day, universal, multi-stage, programmable, touchscreen thermostat
- 3 Heat/2 Cool
- Auto-changeover
- Controls dehumidification during cooling mode and humidification during heating mode
- Offers enhanced capabilities including humidification / dehumidification / dewpoint measurement and control, Humiditol® control, and equipment maintenance reminders
- Easy to read 7 in. color touchscreen (measured diagonally)
- LCD display with backlight shows the current and set temperature, time, inside relative humidity, system status (operating mode and schedules) and outside temperature (optional outdoor sensor required)
- Smooth Setback Recovery starts system early to achieve setpoint at start of program period
- Compressor short-cycle protection (5 minutes)
- Up to four separate schedules are available plus Schedule IQ™
- One-Touch Away Mode - A quick and easy way to set the cooling and heating setpoints while away
- Smart Away™ - Uses geo-fencing technology to determine when the homeowner is within a predetermined distance from the home to operate the system when leaving, away and arriving
- Wi-Fi remote monitoring and adjustment through a home wireless network for desktop PCs, laptops and apps for smartphones or tablets
- Smart home automation compatible with Apple HomeKit™, Amazon Alexa®, Google Assistant and IFTTT
- Service Dashboard features online real-time monitoring of installed iComfort® thermostats
- High Definition Color Display with Subbase, Smart Hub Controller, wallplate (for retrofit installations) furnished for easy installation
- See the iComfort® E30 Smart Wi-Fi Thermostat Product Specifications bulletin for more information



##### Remote Outdoor Temperature Sensor

- Used with the iComfort® Communicating thermostats and the iComfort® E30 Smart Thermostat
- When installed outdoors, sensor allows thermostat to display outdoor temperature

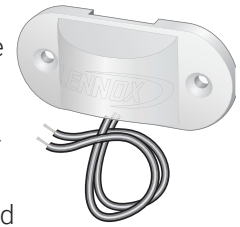

**NOTE** - Sensor is required for Enhanced Dehumidification Control (EDA) applications.

**NOTE** - The outdoor sensor is furnished as standard with iComfort® Communicating outdoor units, optional for conventional units.

##### Thermostat

- Thermostat is not furnished with unit
- See Lennox Price Book for selection

##### Furnace Twinning Kit

- Required to operate two furnaces simultaneously
- Kit consists of twinning relays, quick connect terminals and mounting hardware
- Used for single-stage heating/single-stage cooling with a single-stage thermostat

##### Night Service Kit

- Contains most commonly used service parts:
  - Furnace Control
  - Igniter
  - Flame Sensor
  - Gas Valve
  - Transformer
  - Service Manual

##### BLOWER

- Direct drive blower
- Statically and dynamically balanced
- Resiliently mounted
- Blower assembly easily removed for servicing

##### 8 Power Saver™ Constant Torque Blower Motor

- DC Brushless Motor
- High Efficiency Constant Torque
- ECM (Electronically Commutated Motor)
- Motor is programmed to provide constant torque at each of the selectable speeds
- Motor is controlled by the Integrated Furnace Control
- Blower speeds are easily changed on the integrated furnace control
- See Blower Data tables

## FEATURES

### CABINET

- Low-profile, narrow width cabinet allows easy installation in downflow applications
- Heavy-gauge, cold rolled steel construction
- Pre-painted finish
- Flanges provided on supply air opening for ease of plenum connection or alignment with indoor coil
- 9 • Insulated with foil-faced insulation on sides and back of heating compartment and mat-faced insulation in blower compartment
- Sealed blower compartment
- Inner blower compartment access panel seals blower compartment from air leakage
- Complete service access
- 10 • Safety interlock switch automatically shuts off power to unit when blower compartment access door is removed
- 11 • Gas piping and electrical inlets are provided in both sides of cabinet

### Coil Match-Up

- All Lennox downflow indoor coils will physically match the furnace supply air opening with the same letter designation (A, B, C, D) as in the furnace model number

### Low Leakage Cabinet

- All models have less than 2% air leakage and meet ANSI/ASHRAE Standard 193-2010 "Method of Test for Determining the Air Tightness of HVAC Equipment"

### Optional Accessories

#### Condensate Drain Heat Cable Kits

- Self-limiting wattage heat cable prevents condensate drain from freezing in unconditioned areas
- Available in 6 or 24 ft. lengths

#### Crawl Space Vent Drain Kit

- Allows venting through a crawl space for downflow applications
- Includes 2 or 3 in. sanitary tee, 2 in. PVC assembly, PVC boot and clamp
- Kit for Canada is certified to ULC S636

#### Downflow Combustible Flooring Base

- Required for heating only units installed on combustible floors
- Not required in add-on cooling applications
- See Dimension Drawing

### **FILTER (not furnished)**

### Optional Accessories

#### Downflow Filter Cabinet

- Filter cabinet mounts directly on top of furnace
- "B and "C" width cabinets have two filters
- Filter rails are furnished
- Front access for servicing
- Cleanable filter(s) are furnished

## INSTALLATION CLEARANCES

Sides	<sup>1</sup> 0 inches (0 mm)
Rear	0 inches (0 mm)
Top/Plenum	1 inch (25 mm)
Front	0 inches (0 mm)
Front (service/alcove)	24 inches (610 mm)
Floor	<sup>2</sup> Combustible

NOTE - Air for combustion must conform to the methods outlined in the National Fuel Gas Code (NFPA 54/ANSI-Z223.1) or the National Standard of Canada CAN/CSA-B149.1 "Natural Gas and Propane Installation Code".

NOTE - In the U.S. flue sizing must conform to the methods outlined in the current National Fuel Gas Code (NFPA 54/ANSI-Z223.1) or applicable provisions of local building codes. In Canada flue sizing must conform to the methods outlined in National Standard of Canada CAN/CSA-B149.1.

<sup>1</sup> Allow proper clearances to accommodate condensate trap and vent pipe installation.

<sup>2</sup> Clearance for installation on combustible floor if Optional Downflow Combustible Flooring Base is installed between furnace and combustible floor. Not required in add-on cooling applications if installed in accordance with local codes or National Fuel Gas Code ANSI-Z223.1 or CAN/CGA-149.1,.2. Do not install the furnace directly on carpeting, tile, or other combustible materials other than wood flooring.

## SPECIFICATIONS

		<b>Model No.</b>	<b>EL196DF045XE36B</b>	<b>EL196DF070XE48B</b>	<b>EL196DF090XE48C</b>
<b>Gas Heating Performance</b>	AHRI Ref No.		201849573	201849574	201849575
	<sup>1</sup> AFUE		96%	96%	96%
	Input - Btuh		44,000	66,000	88,000
	Output - Btuh		42,000	64,000	85,000
	Temperature rise range - °F		30 - 60	35 - 65	50 - 80
	Gas Manifold Pressure (in. w.g.) Nat. Gas / LPG/Propane		3.5 / 10	3.5 / 10	3.5 / 10
	High static - in. w.g.		0.5	0.5	0.5
<b>Connections in.</b>	Intake / Exhaust Pipe (PVC)		2 / 2	2 / 2	2 / 2
	Gas pipe size IPS		1/2	1/2	1/2
	Condensate Drain Trap (PVC pipe) - i.d.		3/4	3/4	3/4
	with furnished 90° street elbow		3/4 slip x 3/4 Mipt	3/4 slip x 3/4 Mipt	3/4 slip x 3/4 Mipt
	with field supplied (PVC coupling) - o.d.		3/4 slip x 3/4 MPT	3/4 slip x 3/4 MPT	3/4 slip x 3/4 MPT
<b>Indoor Blower</b>	Wheel nom. diameter x width - in.		10 x 8	11-1/2 x 10	10 x 10
	Motor Type		DC Brushless	DC Brushless	DC Brushless
	Motor output - hp		1/2	3/4	3/4
	Tons of add-on cooling		1.5 - 3	2 - 4	2 - 4
	Air Volume Range - cfm		505 - 1455	525 - 1720	860 - 1760
<b>Electrical Data</b>	Voltage		120 volts - 60 hertz - 1 phase		
	Blower motor full load amps		6.8	8.4	8.4
	Maximum overcurrent protection		15	15	15
<b>Shipping Data</b>	lbs. - 1 package		131	144	160

NOTE - Filters and provisions for mounting are not furnished and must be field provided.

<sup>1</sup> Annual Fuel Utilization Efficiency based on DOE test procedures and according to FTC labeling regulations. Isolated combustion system rating for non-weatherized furnaces.



## OPTIONAL ACCESSORIES - ORDER SEPARATELY

		"B" Width Models	"C" Width Models	
<b>CABINET ACCESSORIES</b>				
Downflow Combustible Flooring Base		11M60	11M61	
<b>CONDENSATE DRAIN KITS</b>				
Condensate Drain Heat Cable	6 ft.	26K68	26K68	
	24 ft.	26K69	26K69	
Crawl Space Vent Drain Kit	US	51W18	51W18	
	Canada	15Z70	15Z70	
<b>CONTROLS</b>				
Blower Relay Kit (for two-stage outdoor units)		85W66	85W66	
Furnace Twinning Kit		16W72	16W72	
iComfort® E30 Smart Wi-Fi Thermostat		20A65	20A65	
Remote Outdoor Temperature Sensor		X2658	X2658	
Night Service Kit		84W48	84W48	
<b>DOWNFLOW FILTER KITS</b>				
¹ Downflow Filter Cabinet		51W07	51W08	
	No. and Size of filter - in.	(2) 16 x 20 x 1	(2) 16 x 20 x 1	
<b>TERMINATION KITS</b>				
See Installation Instructions for specific venting information.				
Direct Vent	Concentric	US - 2 in.	71M80	69M29
		3 in.	---	60L46
		Canada - 2 in.	44W92	44W92
		3 in.	---	44W93
Flush-Mount		US - 2, 2-1/2 or 3 in.	51W11	51W11
		Canada - 2, 2-1/2 or 3 in.	51W12	51W12
Wall - Close Couple		US - 2 in.	22G44	---
		3 in.	44J40	44J40
Wall - Close Couple WTK		Canada - 2 in.	30G28	---
		3 in.	81J20	81J20
Roof Termination Flashing Kit (no vent pipe - 2 flashings)		2 in.	15F75	15F75
		3 in.	44J41	44J41
<b>VENTING</b>				
Flue Coupling		2 in.	17H92	17H92

¹ Cleanable polyurethane frame type filter.

NOTE - Termination Kits (44W92, 44W93, 30G28, 51W12, 81J20) and Crawl Space Vent Drain Kit (15Z70) are certified to ULC S636 standard for use in Canada only.

## GAS HEAT ACCESSORIES

Input	High Altitude Pressure Switch Kit		Natural Gas to LPG/Propane Kit	LPG/Propane to Natural Gas Kit	Natural Gas High Altitude Orifice Kit	LPG/Propane High Altitude Orifice Kit	Muffler (US Only)
	4501 - 7500 ft.	7501 - 10,000 ft.	0 - 7500 ft.	0 - 7500 ft.	7501 - 10,000 ft.	7501 - 10,000 ft.	
045	No Change	11U65	11K49	73W81	73W37	11K44	15Y66 (2-inch)
070	17V95	11U67	11K49	73W81	73W37	11K44	15Y66 (2-inch)
090	11U70	11U64	11K49	73W81	73W37	11K44	15Y66 (2-inch)

## HIGH ALTITUDE DERATE

NOTE - Units may be installed at altitudes up to 10,000 ft.

At altitudes above 4501 ft. the unit must be derated to match the manifold pressure information shown below.

Units installed at altitudes of 4501 to 10,000 ft. require a pressure switch change.

Units installed at altitudes of 7501 to 10,000 ft. require an orifice change.

See the Gas Heat Accessories table for ordering information.

NOTE - This is the only permissible derate for these units.

NOTE - In Canada, certification for installations at elevations over 4500 feet is the jurisdiction of local authorities.

Input	Gas	Manifold Pressure in. w.g.					Supply Line Pressure in. w.g.	
		0 - 4500 ft.	4501 - 5500 ft.	5501 - 6500 ft.	6501 - 7500 ft.	7501 - 10,000 ft.	0 - 10,000 ft.	
							Min.	Max.
All Sizes	Natural	3.5	3.3	3.2	3.1	3.5	4.5	13.0
	LPG/Propane	10.0	9.4	9.1	8.9	10.0	11.0	13.0

## OUTDOOR TERMINATION KIT USAGE

Input Size	Vent Pipe Diameter (in.)	Standard Terminations			Field Fabricated Exhaust Accelerator Size Required	Concentric Terminations		
		Flush Mount Kit	Wall Kit			Concentric Kit		
			2 inch	3 inch		1-1/2 inch	2 inch	3 inch
			51W11 (US) 5 51W12 (CA)	22G44 (US) 5 30G28 (CA)		44J40 (US) 5 81J20 (CA)	71M80 (US) 5 44W92 (CA)	69M29 (US) 5 44W92 (CA)
045	1 1-1/2	4 YES	YES	2 YES	1-1/2 in.	3 YES	---	---
	2	4 YES	YES	2 YES	1-1/2 in.	3 YES	---	---
	2-1/2	4 YES	YES	2 YES	1-1/2 in.	3 YES	---	---
	3	4 YES	YES	2 YES	1-1/2 in.	3 YES	---	---
070	1 1-1/2	4 YES	YES	2 YES	1-1/2 in.	3 YES	---	---
	2	4 YES	YES	2 YES	1-1/2 in.	3 YES	---	---
	2-1/2	4 YES	YES	2 YES	1-1/2 in.	3 YES	---	---
	3	4 YES	YES	2 YES	1-1/2 in.	3 YES	---	---
090	2	4 YES	---	YES	2 in.	---	YES	YES
	2-1/2	4 YES	---	YES	2 in.	---	YES	YES
	3	4 YES	---	YES	2 in.	---	YES	YES
110	2	YES	---	YES	2 in.	---	YES	YES
	2-1/2	YES	---	YES	2 in.	---	YES	YES
	3	YES	---	YES	2 in.	---	YES	YES

NOTE - Standard Terminations do not include any vent pipe or elbows external to the structure.

Any vent pipe or elbows external to the structure must be included in total vent length calculations. See Vent Length Tables.

<sup>1</sup> 2 inch to 1-1/2 inch reducer required, must be field provided.

<sup>2</sup> Requires field provided 1-1/2 in. outdoor exhaust accelerator.

<sup>3</sup> Concentric Kits 71M80 and 44W92 include 1-1/2 in. outdoor exhaust accelerator, required when used with 030, 045 and 070 input models. Accelerator is not used with 090 or 110 input models. When using 1-1/2 in. piping, the pipe must be transitioned to 2 in. pipe when used with the Concentric Kit.

<sup>4</sup> Flush Mount Kit 51W11 and 51W12 includes 1-1/2 in. outdoor exhaust accelerator, required when used with 030, 045, 070 and 090 input models. Accelerator is not used with 110 input models. When using 1-1/2 in. piping, the pipe must be transitioned to 2 in. pipe when used with the Flush Mount Kit.

<sup>5</sup> Termination Kits 30G28, 44W92, 44W93, 51W12 and 81J20 are certified to ULC S636 standard for use in Canada only.

## VENT LENGTHS

### STANDARD TERMINATION AT ELEVATION 0 - 10,000 ft.

	Pipe Size Input	1-1/2 in.				2 in.				2-1/2 in.				3 in.			
		045	070	090	110	045	070	090	110	045	070	090	110	045	070	090	110
No. of 90 ELL	1	15	15	N/A	N/A	81	66	44	24	115	100	68	43	137	137	118	118
	2	10	10	N/A	N/A	76	61	39	19	110	95	63	38	132	132	113	113
	3	N/A	N/A	N/A	N/A	71	56	34	14	105	90	58	33	127	127	108	108
	4	N/A	N/A	N/A	N/A	66	51	29	N/A	100	85	53	28	122	122	103	103
	5	N/A	N/A	N/A	N/A	61	46	24	N/A	95	80	48	23	117	117	98	98
	6	N/A	N/A	N/A	N/A	56	41	19	N/A	90	75	43	18	112	112	93	93
	7	N/A	N/A	N/A	N/A	51	36	14	N/A	85	70	38	13	107	107	88	88
	8	N/A	N/A	N/A	N/A	46	31	N/A	N/A	80	65	33	N/A	102	102	83	83
	9	N/A	N/A	N/A	N/A	41	26	N/A	N/A	75	60	28	N/A	97	97	78	78
	10	N/A	N/A	N/A	N/A	36	21	N/A	N/A	70	55	23	N/A	92	92	73	73

### CONCENTRIC TERMINATION ELEVATION 0 - 10,000 ft.

	Pipe Size Input	1-1/2 in.				2 in.				2-1/2 in.				3 in.			
		045	070	090	110	045	070	090	110	045	070	090	110	045	070	090	110
No. of 90 ELL	1	10	10	N/A	N/A	73	58	42	22	105	90	64	39	121	121	114	114
	2	N/A	N/A	N/A	N/A	68	53	37	17	100	85	59	34	116	116	109	109
	3	N/A	N/A	N/A	N/A	63	48	32	12	95	80	54	29	111	111	104	104
	4	N/A	N/A	N/A	N/A	58	43	27	N/A	90	75	49	24	106	106	99	99
	5	N/A	N/A	N/A	N/A	53	38	22	N/A	85	70	44	19	101	101	94	94
	6	N/A	N/A	N/A	N/A	48	33	17	N/A	80	65	39	14	96	96	89	89
	7	N/A	N/A	N/A	N/A	43	28	12	N/A	75	60	34	N/A	91	91	84	84
	8	N/A	N/A	N/A	N/A	38	23	N/A	N/A	70	55	29	N/A	86	86	79	79
	9	N/A	N/A	N/A	N/A	33	18	N/A	N/A	65	50	24	N/A	81	81	74	74
	10	N/A	N/A	N/A	N/A	28	13	N/A	N/A	60	45	19	N/A	76	76	69	69

NOTES - Additional vent pipe and elbows used to terminate vent pipe outside the structure must be included in the total vent length calculation.  
 Intake and exhaust pipes are sized separately.  
 Values in table are for separate intake or exhaust pipe lengths.  
 Both intake and exhaust pipe must be the same size diameter.

## VENT LENGTHS - UNINSULATED EXHAUST PIPE IN UNCONDITIONED SPACE

1 Winter Design Temperatures	Vent Pipe Diameter	Unit Input Size					
		045		070		090	
		Maximum Uninsulated Exhaust Vent Length (ft.)					
		PVC	PolyPro InnoFlue	PVC	PolyPro InnoFlue	PVC	PolyPro InnoFlue
32 to 21°F	1-1/2 in.	20	N/A	20	N/A	N/A	N/A
	2 in.	18	16	31	28	50	48
	2-1/2 in.	13	N/A	24	N/A	42	N/A
	3 in.	9	9	18	18	35	35
20 to 1°F	1-1/2 in.	15	N/A	20	N/A	N/A	N/A
	2 in.	9	8	18	16	32	29
	2-1/2 in.	5	N/A	13	N/A	24	N/A
	3 in.	N/A	N/A	8	8	19	19
0 to -20°F	1-1/2 in.	10	N/A	15	N/A	N/A	N/A
	2 in.	5	N/A	12	10	22	19
	2-1/2 in.	N/A	N/A	7	N/A	15	N/A
	3 in.	N/A	N/A	N/A	N/A	10	10

NOTE - Concentric terminations are equivalent to 5 ft. of straight pipe and should be included when measuring total pipe length.

NOTE - Each elbow is equivalent to 5 ft. of straight pipe and should be included when measuring total pipe length.

<sup>1</sup> Refer to 99% Minimum Design Temperature table provided in the current edition of the ASHRAE Handbook-Fundamentals.

PolyPro® poly-propylene vent pipe is a registered trademark of DuraVent®.

InnoFlue® is a registered trademark of Centrotherm Eco Systems.

## BLOWER DATA

### EL196DF045XE36B PERFORMANCE (Less Filter)

External Static Pressure in. w.g.	Air Volume / Watts at Various Blower Speeds									
	High (Black)		Medium-High (Brown)		Medium (Blue)		Medium-Low (Yellow)		Low (Red)	
	cfm	Watts	cfm	Watts	cfm	Watts	cfm	Watts	cfm	Watts
0.00	1455	370	1275	255	1175	190	920	90	865	85
0.10	1425	375	1250	260	1145	200	885	100	830	90
0.20	1395	380	1225	265	1115	210	850	110	795	95
0.30	1365	385	1195	275	1085	220	815	115	750	105
0.40	1325	385	1170	290	1045	230	770	130	700	110
0.50	1245	370	1130	300	1010	240	720	135	660	120
0.60	1180	360	1095	305	970	245	675	140	605	125
0.70	1100	330	1045	310	935	255	615	150	560	130
0.80	980	295	1000	290	895	260	580	155	505	135

### EL196DF070XE48B PERFORMANCE (Less Filter)

External Static Pressure in. w.g.	Air Volume / Watts at Various Blower Speeds									
	High (Black)		Medium-High (Brown)		Medium (Blue)		Medium-Low (Yellow)		Low (Red)	
	cfm	Watts	cfm	Watts	cfm	Watts	cfm	Watts	cfm	Watts
0.00	1720	510	1545	355	1340	235	1240	190	1020	95
0.10	1700	530	1505	360	1310	245	1195	200	955	110
0.20	1675	545	1465	370	1275	255	1155	205	895	115
0.30	1640	555	1420	380	1230	270	1120	215	835	125
0.40	1600	565	1380	395	1180	280	1060	225	785	135
0.50	1560	570	1340	400	1140	290	1015	235	715	145
0.60	1500	565	1300	420	1095	305	965	245	640	150
0.70	1405	540	1255	430	1040	315	910	255	585	160
0.80	1325	515	1215	445	990	320	865	265	525	170

### EL196DF090XE48C PERFORMANCE (Less Filter)

External Static Pressure in. w.g.	Air Volume / Watts at Various Blower Speeds									
	High (Black)		Medium-High (Brown)		Medium (Blue)		Medium-Low (Yellow)		Low (Red)	
	cfm	Watts	cfm	Watts	cfm	Watts	cfm	Watts	cfm	Watts
0.00	1760	435	1555	280	1405	230	1315	175	1190	135
0.10	1730	445	1515	300	1375	240	1280	190	1150	145
0.20	1700	455	1475	315	1350	250	1245	205	1115	155
0.30	1670	465	1445	330	1310	265	1200	220	1070	165
0.40	1640	480	1410	340	1265	275	1160	230	1025	175
0.50	1590	485	1380	345	1225	285	1125	235	985	185
0.60	1530	465	1340	360	1195	295	1085	245	945	195
0.70	1445	450	1315	370	1150	305	1065	255	895	200
0.80	1350	420	1280	375	1115	315	1015	265	860	210

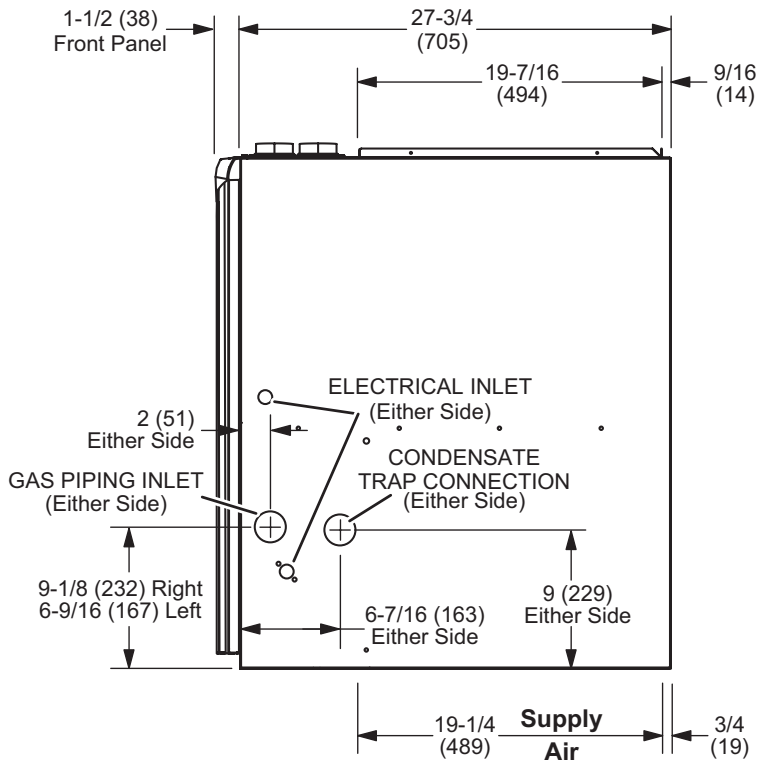
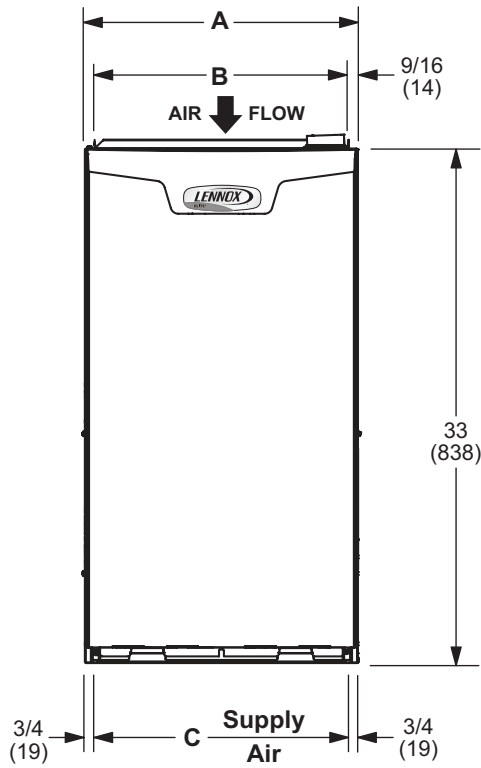
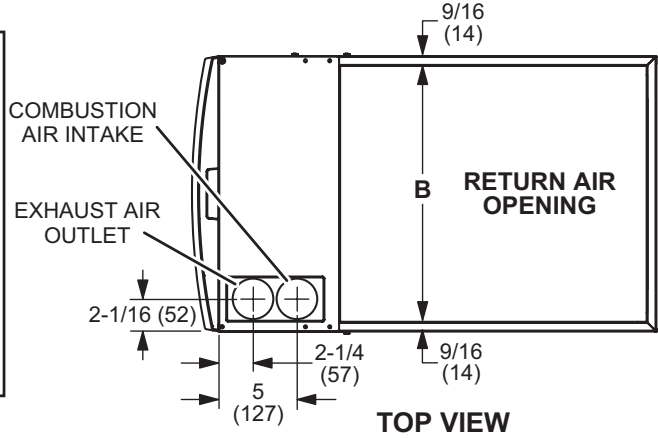
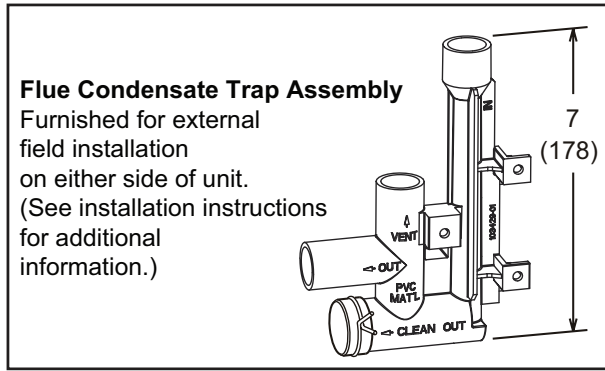

Model No.	A		B		C	
	in.	mm	in.	mm	in.	mm
EL196DF045XE36B EL196DF070XE48B	17-1/2	446	16-3/8	416	16	406
EL196DF090XE48C	21	533	19-7/8	505	19-1/2	495

**DOWNFLOW COMBUSTIBLE FLOORING BASE**

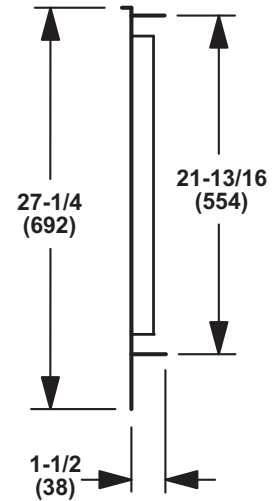
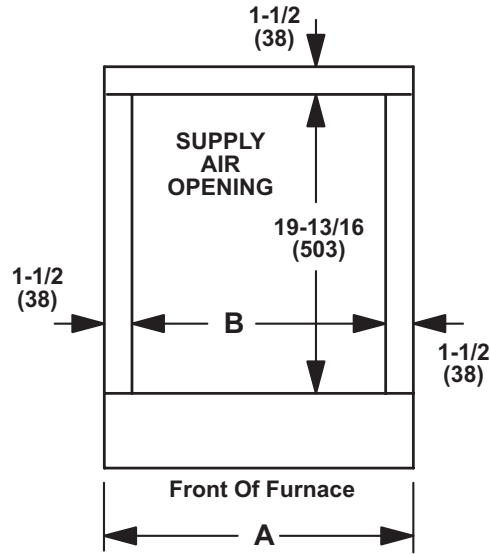
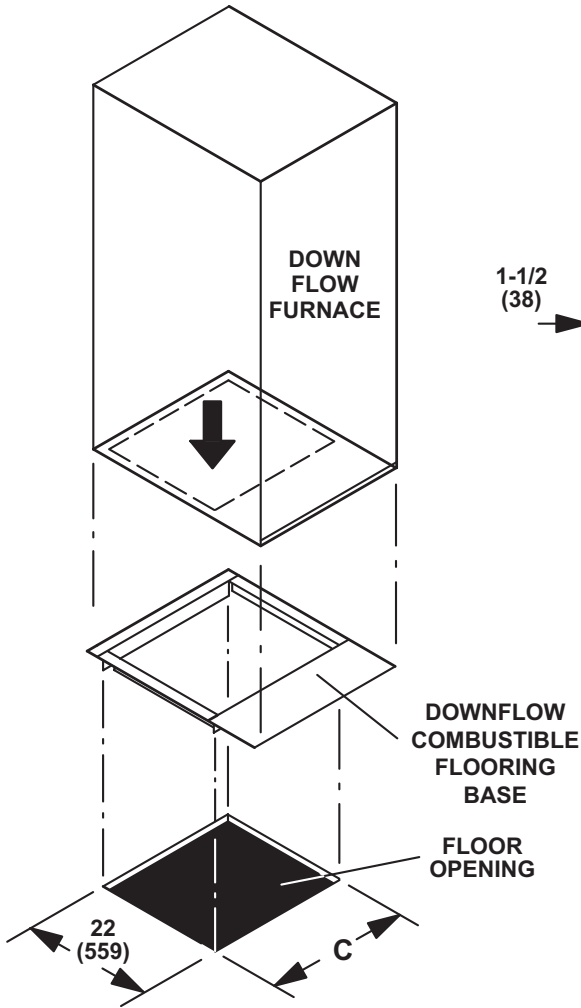

**TOP VIEW**

**SIDE VIEW**

Cabinet Width	Catalog Number	A		B		C	
		in.	mm	in.	mm	in.	mm
B	11M60	19-9/16	497	16-9/16	421	18-3/4	476
C	11M61	23-1/16	586	20-1/16	510	22-1/4	565

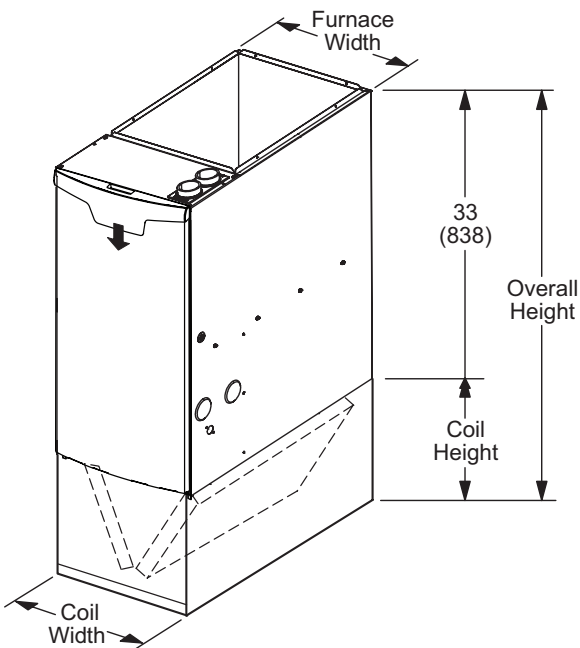

Model Number	Coil Width		Furnace Width		Coil Height		Overall Height	
	in.	mm	in.	mm	in.	mm	in.	mm
CR33-24B-F	17-1/2	446	17-1/2	446	13-1/4	337	46-1/4	1175
CR33-30/36B-F	17-1/2	446	17-1/2	446	16-1/8	410	49-1/8	1248
CR33-30/36C-F	21	533	21	533	16-1/8	410	49-1/8	1248
CR33-48B-F	21	533	17-1/2	446	20	508	53	1346
CR33-48C-F	21	533	21	533	20	508	53	1346
CR33-50/60C-F	24-1/2	622	21	533	23-5/8	600	56-5/8	2276

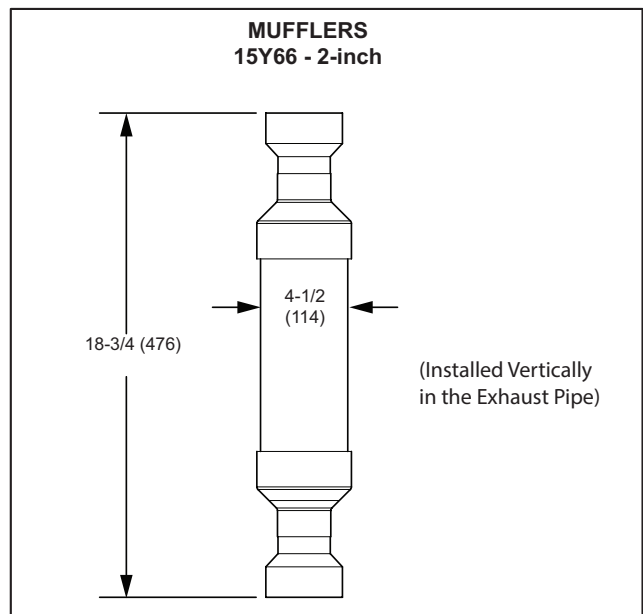
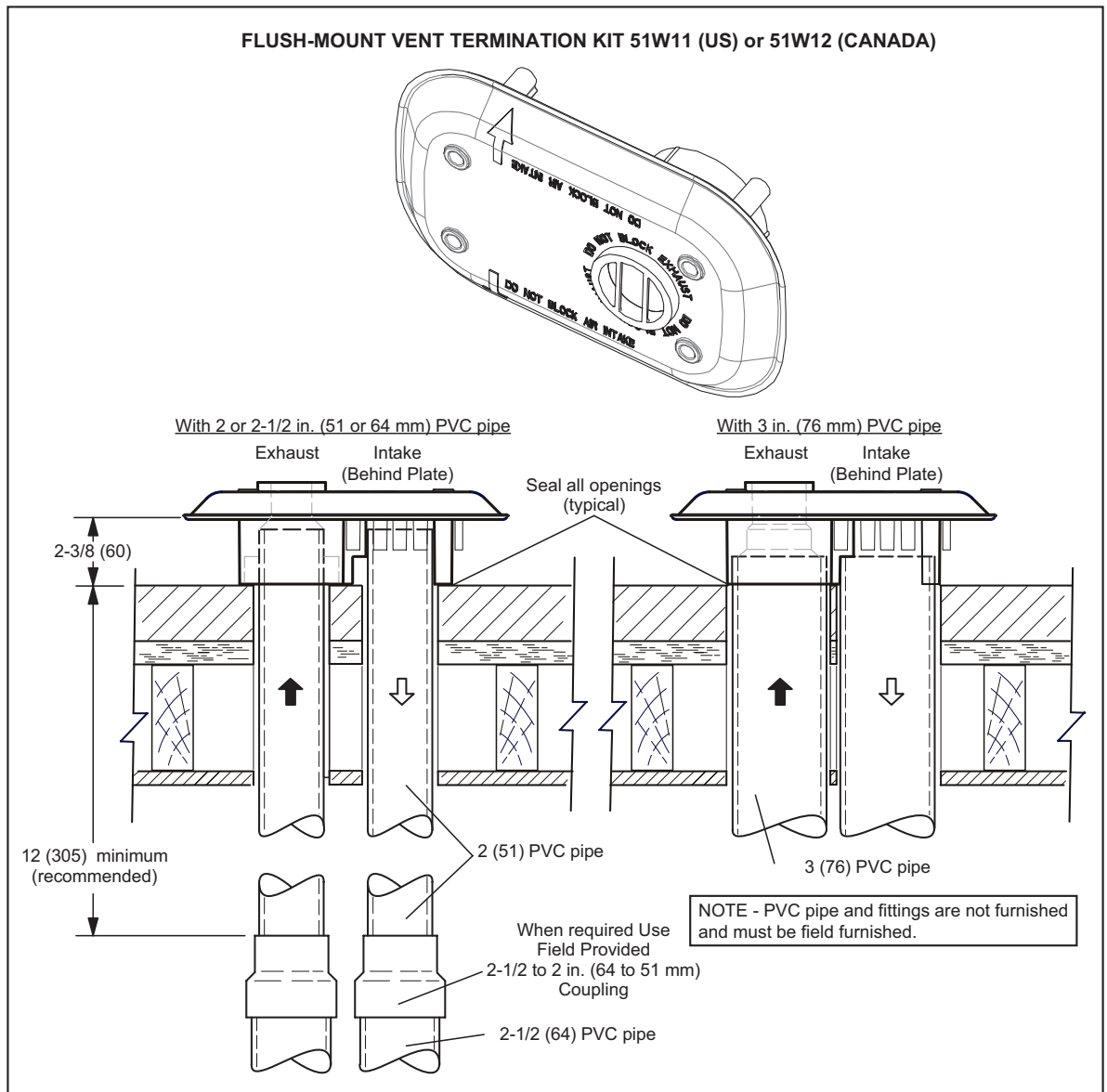

**CONCENTRIC WALL  
TERMINATION APPLICATIONS**

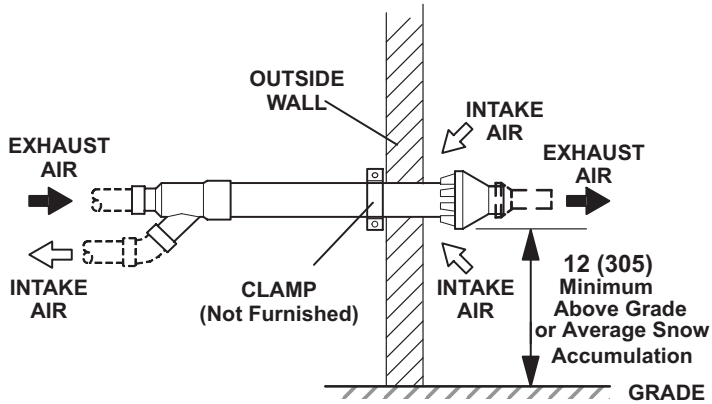

**CONCENTRIC ROOF  
TERMINATION APPLICATIONS**

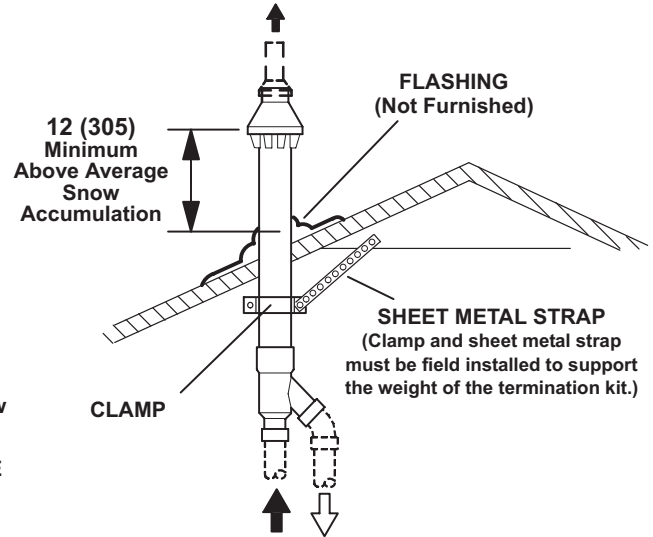

**71M80 / 69M29 / 44W92 – 2 inch kits**

**60L46 / 44W93 – 3 inch kits**

**See Installation Instructions for additional information.**

Note - Field provided reducer may be required to adapt different vent pipe sizes to termination.

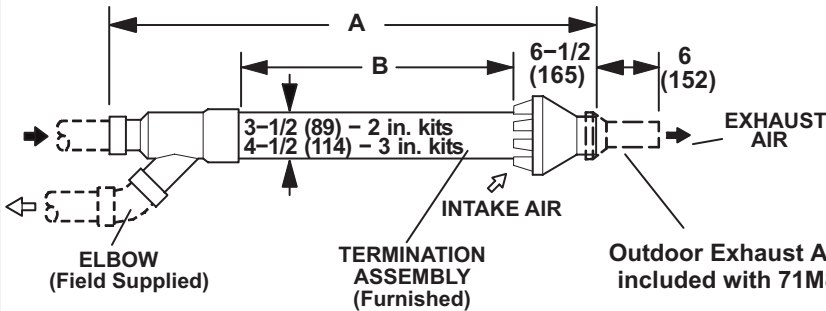

Cat. No.	A		B	
	in.	mm	in.	mm
71M80 69M29	33-3/8	848	16-3/4	425
44W92 (Canada)	29	737	15-1/2	394
60L46	38-7/8	987	21-3/16	538
44W93 (Canada)	36-1/8	918	19-1/2	495

**NOTE - Typical illustration for dimensions only. Design may vary depending on kit ordered.**



**WALL TERMINATION KITS (CLOSE-COUPLE)  
EXTENDED VENT FOR GRADE CLEARANCE  
2 inch (51 mm) 22G44 (US)  
3 inch (76 mm) 44J40 (US)**

**See Installation Instructions for additional information.**

Note - Field provided reducer may be required to adapt different vent pipe sizes to termination.

If Intake and Exhaust Pipe is less than 12 in. (305 mm) above snow accumulation or other obstructions, field fabricated piping must be installed.

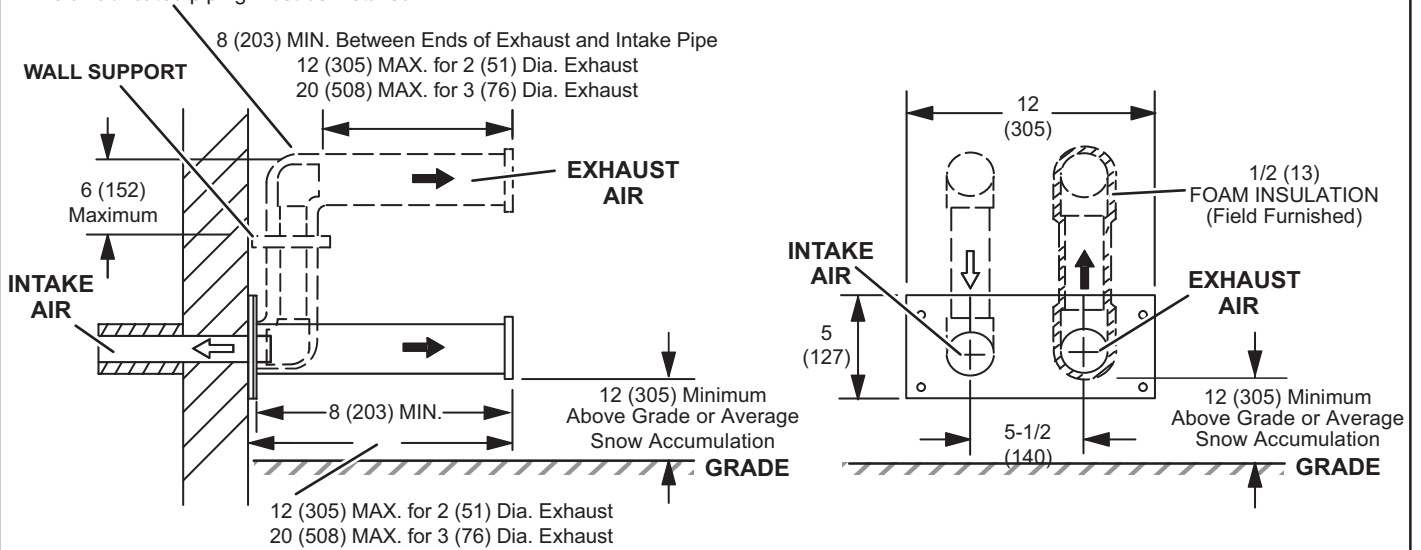

**WALL TERMINATION KITS (CLOSE-COUPLE)  
EXTENDED VENT FOR GRADE CLEARANCE  
2 inch (51 mm) 30G28 (WTK Canada)  
3 inch (76 mm) 81J20 (WTK Canada)**

**See Installation Instructions for additional information.**

Note - Field provided reducer may be required to adapt different vent pipe sizes to termination.

If Intake and Exhaust Pipe is less than 12 in. (305 mm) above snow accumulation or other obstructions, field fabricated piping must be installed.

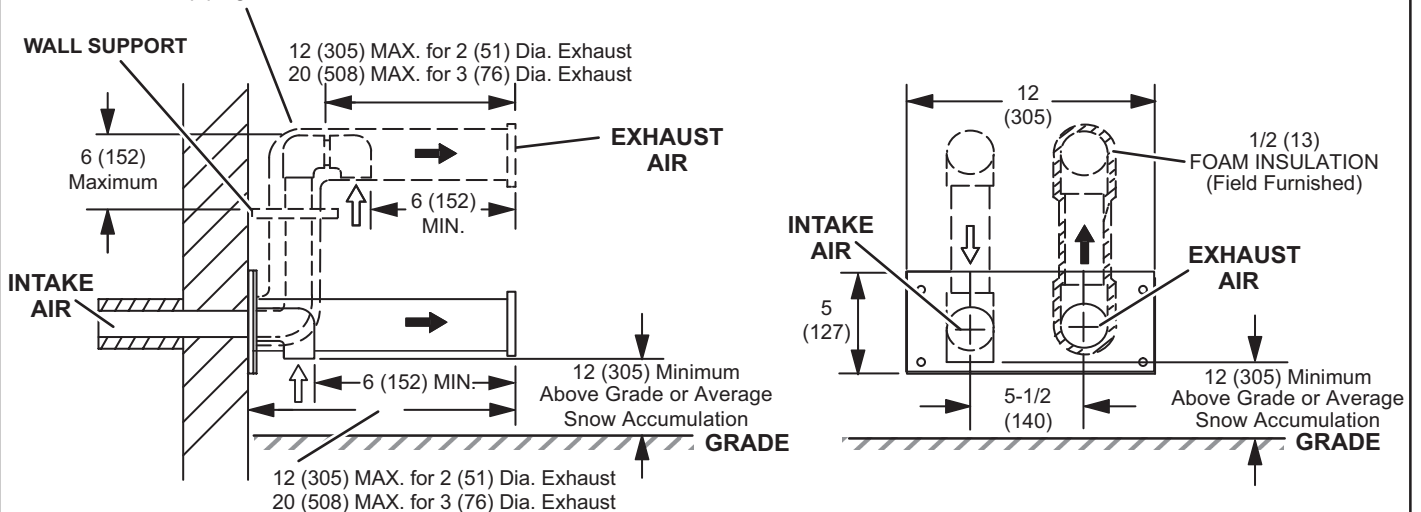





## REVISIONS

Sections	Description of Change
Optional Accessories	Removed Wall Ring Kit (discontinued).



Visit us at [www.Lennox.com](http://www.Lennox.com)

For the latest technical information, [www.LennoxPros.com](http://www.LennoxPros.com)

Contact us at 1-800-4-LENNOX

NOTE - Due to Lennox' ongoing commitment to quality, Specifications, Ratings and Dimensions subject to change without notice and without incurring liability. Improper installation, adjustment, alteration, service or maintenance can cause property damage or personal injury. Installation and service must be performed by a qualified installer and servicing agency.

©2021 Lennox Industries, Inc.