

**LENNOX****PRODUCT SPECIFICATIONS**

Bulletin No. 210090

June 2009

Supersedes July 1995

**FEATURES****Application**

Designed for applications requiring outdoor air to be utilized in a HVAC system. The versatile EMD14 damper unit will allow the entry of fresh outdoor air for free cooling, reducing the requirement for mechanical cooling. The standard EMD14-65 model is equipped with a 24 volt, three-position electronic spring- return damper motor. An optional EMD14M-65 model with a fully modulating damper motor is also available and must be ordered separately.

**Cabinet**

Damper cabinet is constructed of heavy gauge galvanized steel with a durable baked-on paint finish and is lined with thick fiberglass insulation. Three air inlet openings provide a choice of recirculated or outdoor air inlets. Air opening cover is furnished for opening not required. Openings have flanges for ease of duct connection. Large access panels on both sides of the cabinet provide complete service entry. Panels have handles for ease of removal.

**Dampers and Controls**

Formed, low-leakage dampers rotate smoothly in nylon bearings and are gasketed for tight seal. The positioning of the outdoor air and recirculated air dampers is accomplished by a 24 volt, three-position electronic spring return damper motor with adjustable minimum position switch and controlled by the room thermostat, electronic discharge air sensor and solid-state adjustable outdoor air enthalpy control. The enthalpy control allows 0 to 100% outdoor air to be used for "free cooling" when outdoor humidity and temperature are acceptable.

**OPTIONS****Differential Enthalpy Control**

Solid-state return air enthalpy sensor (**54G44**) field installs in the damper cabinet and is used in conjunction with the outdoor air enthalpy control to determine which air has the lowest enthalpy. The air with the lowest enthalpy will be selected.

**Wiring Harness Kit**

Allows economizer and furnace/air handler to be used with various electronic thermostat control systems with plug-in connections. Kit (**55H53**) contains control box with relay, terminal strip, and wiring harness. Must be ordered extra for field installation in air handler.

**AIR RESISTANCE**

| Air Volume - cfm | Total Resistance - in.w g. |
|------------------|----------------------------|
| 600              | .02                        |
| 800              | .03                        |
| 100              | .05                        |
| 1200             | .06                        |
| 1400             | .07                        |
| 1600             | .10                        |
| 1800             | .12                        |
| 2000             | .15                        |
| 2200             | .18                        |
| 2400             | .23                        |
| 2600             | .28                        |

## OPTIONAL CONVENTIONAL TEMPERATURE CONTROL SYSTEMS - FIELD INSTALLED

### COMMERCIAL TOUCHSCREEN THERMOSTAT



Intuitive Touchscreen Interface - **Two Stage Heating / Two Stage Cooling Conventional or Heat Pump** - Seven Day Programmable - Four Time Periods/Day - Economizer Output - Title 24 Compliant - ENERGY STAR® Qualified - Backlit Display - Automatic Changeover

C0STAT02AE1L

#### Sensors For Touchscreen Thermostat

|   |              |
|---|--------------|
| 1 Remote non-adjustable wall mount 20k temperature sensor .....           | C0SNZN01AE1- |
| 1 Remote non-adjustable wall mount 10k averaging temperature sensor ..... | C0SNZN73AE1- |
| 1 Remote non-adjustable duct mount temperature sensor .....               | C0SNDC00AE1- |
| Outdoor temperature sensor .....  | C0SNSR03AE1- |

#### Accessories For Touchscreen Thermostat

|                             |              |
|-----------------------------|--------------|
| Locking cover (clear) ..... | C0MISC15AE1- |
|-----------------------------|--------------|

<sup>1</sup> Remote sensors for C0STAT02AE1L can be applied in the following combinations: (1) C0SNZN01AE1-, (2) C0SNZN73AE1-, (2) C0SNZN01AE1- and (1) C0SNZN73AE1-, (4) C0SNZN01AE1-, (3) C0SNZN01AE1- and (2) C0SNZN73AE1.

## DIMENSIONS - INCHES (MM)

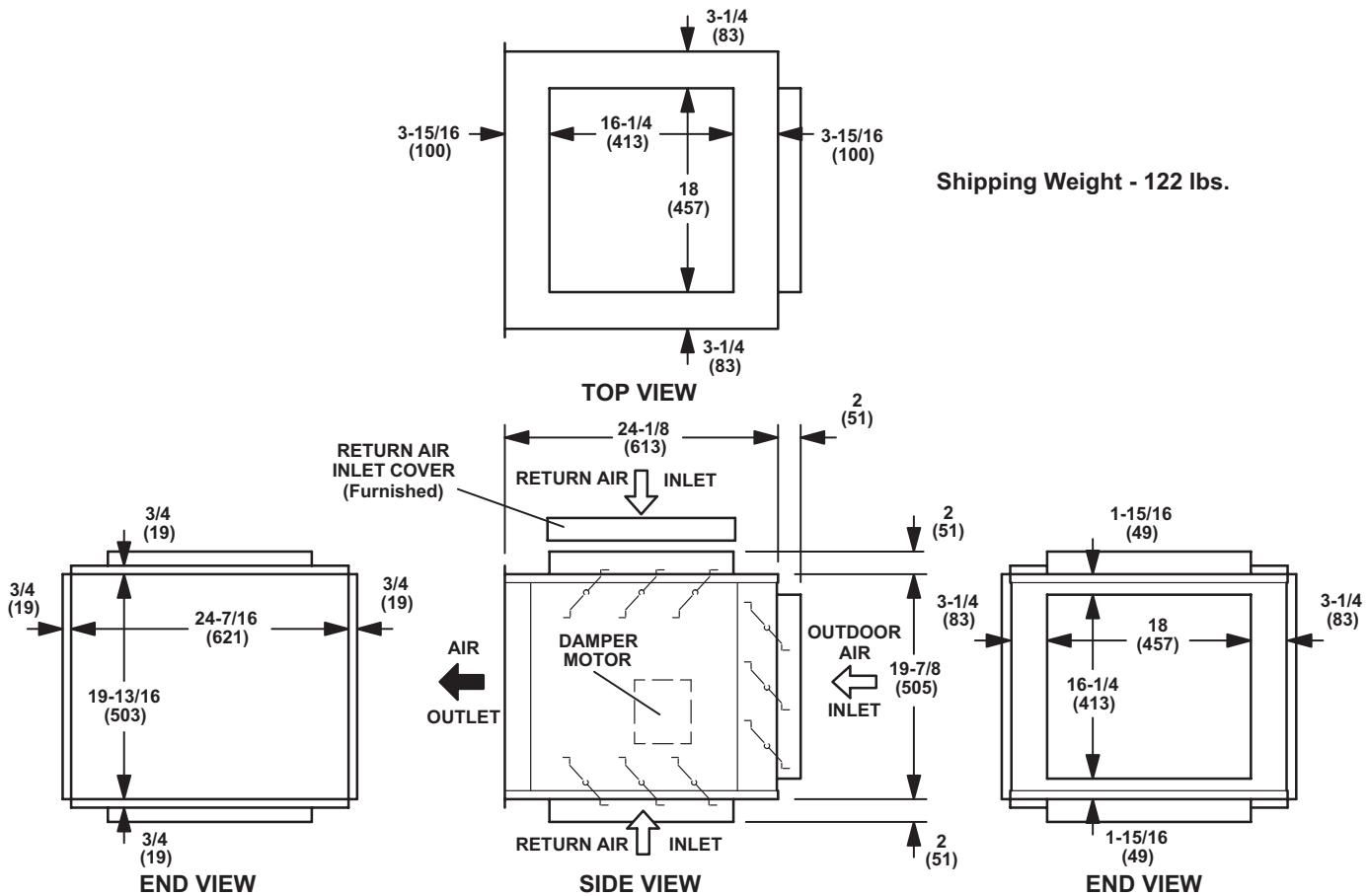

Visit us at [www.lennox.com](http://www.lennox.com)

For the latest technical information, [www.lennox.com](http://www.lennox.com)

Contact us at 1-800-4-LENNOX

NOTE - Due to Lennox' ongoing commitment to quality, Specifications, Ratings and Dimensions subject to change without notice and without incurring liability. Improper installation, adjustment, alteration, service or maintenance can cause property damage or personal injury. Installation and service must be performed by a qualified installer and servicing agency.

©2009 Lennox Industries, Inc.