

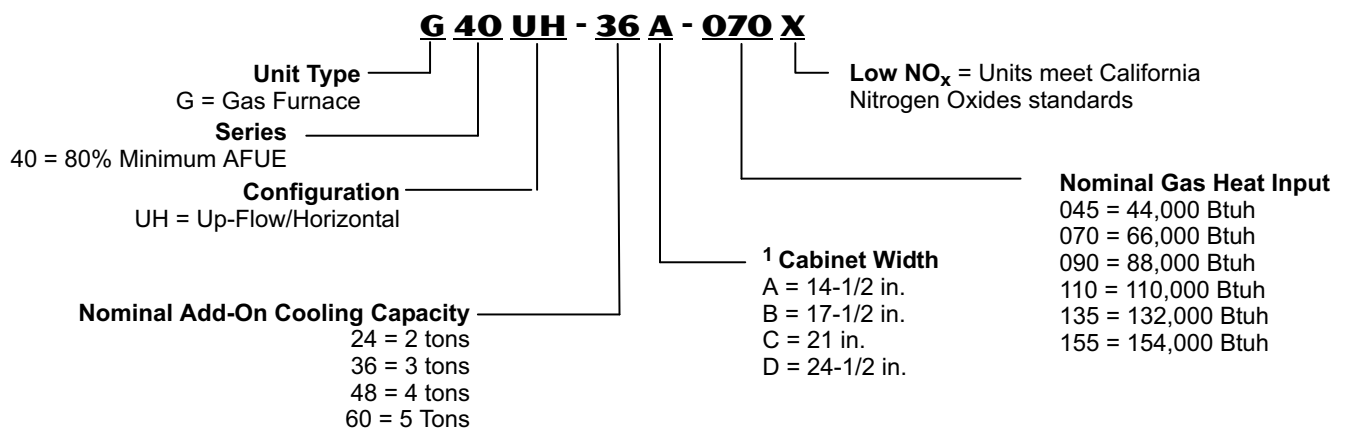

**AFUE - 80%**  
**Input - 44,000 to 154,000 Btuh**  
**Nominal Add-on Cooling - 1.5 to 5 Tons**

**MODEL NUMBER IDENTIFICATION**



<sup>1</sup> Indoor coils with the same letter designation will physically match the furnace.

## FEATURES

### CONTENTS

Blower Data .....	Pages 12-14
Dimensions .....	Pages 8-11
Features and Options .....	Pages 2-4
Filter Air Resistance .....	Page 6
Installation Clearances .....	Page 7
Model Number Identification .....	Page 1
Optional Accessories .....	Page 6
Specifications .....	Page 5
Winter Design Temperature Map .....	Page 7

### WARRANTY

**Duralok® Aluminized Steel Heat Exchangers - Limited twenty year warranty** in residential applications, ten years in non-residential applications.

**All Other Covered Components - Limited five year warranty** in residential applications, one year in non-residential applications.

### APPROVALS

Units certified by CSA International and ratings are certified by GAMA.

Units tested and rated according to US DOE test procedures and FTC labeling regulations.

Approved by California Energy Commission and meet California Seasonal Efficiency requirements and California Nitrogen Oxides (NO<sub>x</sub>) Standards.

“X” models meet California Nitrogen Oxides (NO<sub>x</sub>) Standards.

Blower data from unit tests conducted in Lennox Laboratory air test chamber.

ISO 9001 Registered Manufacturing Quality System.

### APPLICATIONS

Input capacities of 44,000, 66,000, 88,000, 110,000, 132,000 and 154,000 Btuh.

Energy efficiency (AFUE) of 80%.

G40UH24A-70 and G40UH36C-110 models are available only in Canada.

Utility room, alcove, closet, crawl space or attic installation.

Lennox add-on indoor coils, high-efficiency air cleaners and humidifiers can easily be added to furnace.

Shipped factory assembled with all controls installed and wired.

Ready for installation in up-flow or horizontal left or right hand position without any modifications. Removeable bottom seal panel shipped in place for side return air is easily removed for bottom/end return air applications.

Each unit factory test operated to ensure proper operation.

### HEATING SYSTEM

#### 1 Lennox Duralok® Aluminized Steel Heat Exchanger

Heavy gauge aluminized steel heat exchanger.

Crimped seam clamshell type design.

Designed for normal expansion and contraction.

Minimum resistance to air flow.

Heat exchanger has been laboratory life cycle tested.

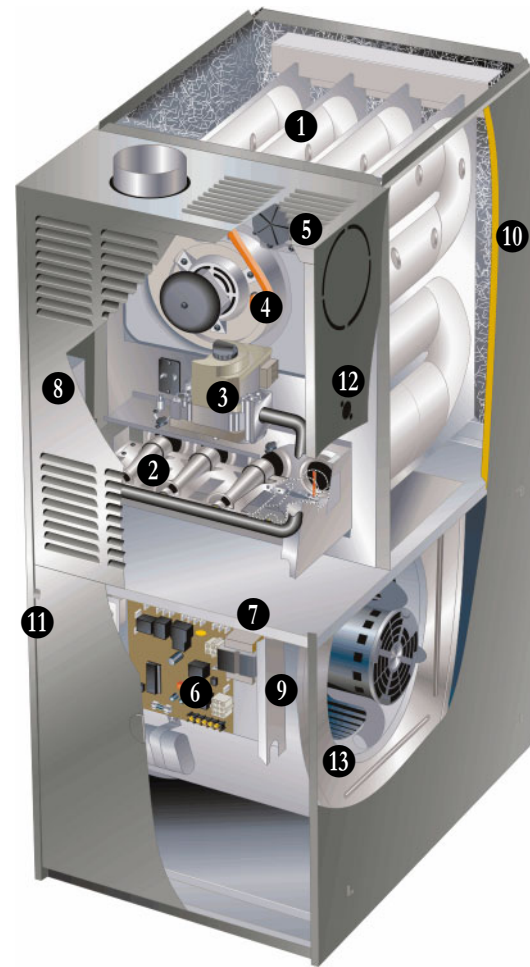

#### 2 Inshot Burners

Aluminized steel inshot burners.

Burner venturi mixes air and gas in correct proportion for proper combustion.

Burner assembly is removeable from the unit as a single component for servicing.

#### Hot Surface Mini-Nitride Ignitor

Unique, non-porous, high strength proprietary ceramic material provides long life and trouble-free maintenance. Low mass element provides fast heat-up and consistent igniter temperature with low power usage.

Cemented to alumina block for positive mounting and protection against current leakage.

High temperature Teflon® insulated ignition lead wires for dependable operation.

#### 3 Gas Control Valve

24 volt redundant combination gas control valve combines manual shut off valve (On-Off), automatic electric valve (dual) and gas pressure regulation into a compact combination control.

## FEATURES

### Flame Rollout Switches (2)

Manual reset.

Factory installed on burner box.

Switches provide protection from abnormal operating conditions.

### 4 Combustion Air Inducer

Shaded pole heavy duty blower prepurges heat exchanger and safely vents flue products.

### 5 Pressure switch proves blower operation before allowing gas valve to open.

Operates only during heating cycle.

Direct access allows inducer assembly to be rotated 90° clockwise or counterclockwise to facilitate easy vent attachment in horizontal applications.

### Limit Controls

Automatic reset, primary and secondary limits are accurately located.

Primary limit factory installed on vestibule panel on all units, secondary limit(s) (all units except G40UH-24A-045) factory installed on blower housing.

## OPTIONS

### High Altitude Orifice Kit - Natural Gas Only

Required for all natural gas models for proper unit operation at altitudes of 7501 to 10,000 feet.

### High Altitude Pressure Switch Kit

Required on certain units for proper unit operation on installations above 7,500 ft.

### LPG/Propane Conversion Kit

Required for field changeover from natural gas to LPG/Propane

### Vent Adaptor (Up-Flow Applications Only)

Allows venting through a masonry chimney without the need of a flue liner.

Manual reset temperature sensor protects against abnormal operating conditions - manual reset.

Sensor wiring may be routed from either side of adaptor.

Minimum winter design temperatures:

-10°F for -45, -70, -90, and

-135 models.

+5°F for -110 models.

Refer to Winter Design Temperatures Map on page 7 for application information. Also refer to the installation instructions for detailed information.

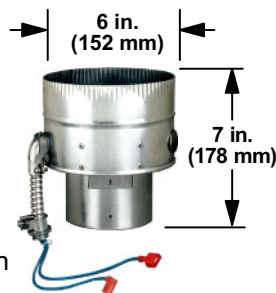

## CONTROLS

### 6 Integrated Furnace Control Board

Solid-state board contains all necessary controls and relays to operate furnace.

Combustion air inducer is controlled by board. Prior to ignition, a pre-purge cycle for 15 seconds is initiated. After the main burners are turned off, a post-purge cycle for 5 seconds is run.

Ignition control board continuously monitors line voltage and maintains the igniter power at a constant level to provide consistent lighting and maximum igniter life.

Electronic flame sensor control assures safe and reliable operation.

Should loss of flame occur, flame sensor controls will initiate 4 attempts at re-ignition before locking out unit operation for 60 minutes.

Watchguard type circuit automatically resets ignition controls after one hour of continuous thermostat demand after unit lockout, eliminating nuisance calls for service.

Fan control consists of adjustable blower timed-off delay (60, 90, 120, 180 seconds - factory setting 90 seconds) and fixed blower timed-on delay (45 seconds).

For air-conditioning applications, blower is automatically energized on thermostat demand for cooling.

### 7 Two accessory terminals furnished for additional power supply requirements for 120 volt (less than 1 amp) power humidifiers and powered air cleaners.

Ignition control has two LED's to indicate status and as an aid in troubleshooting.

### 8 Field Wiring Make-up Box

Furnished for line voltage wiring.

Factory installed internally on left side of furnace.

Box may be installed internally or externally on either side of furnace.

### 9 24 Volt Transformer

Furnished and factory installed in control box.

40VA transformer has fuse wired in series.

## OPTIONS

### Furnace Twinning Kit

Required to operate two furnaces simultaneously.

Kit consists of twinning control and two fan sensors.

### Thermostat

See Thermostat bulletins in Controls section and Lennox Price Book for a complete list of thermostats.

## FEATURES

### CABINET

Low profile, narrow width cabinet allows easy installation.  
Heavy gauge cold rolled steel constructed.  
Pre-painted cabinet finish.  
Flue outlet on top of cabinet for up-flow applications, can be relocated to either side of cabinet for horizontal applications.

Flanges provided on supply air opening for ease of plenum connection or alignment with indoor coil.

- 10 Insulated cabinet with foil faced insulation on sides and back of heating compartment.

Gasketed blower compartment provides tight seal and minimizes air infiltration.

- 11 Complete service access.

Safety interlock switch automatically shuts off power to unit when blower compartment access door is removed.

- 12 Gas piping and electrical inlets are provided in both sides of cabinet.

#### Return Air Entry:

For bottom/end entry for up-flow/horizontal applications - remove furnished bottom seal panel from cabinet.

For side return air entry for up-flow applications - corners are marked on either side of cabinet for return air cut-outs. See dimension drawings.

NOTE - 60C and 60D size units that require air volumes over 1800 cfm must have one of the following:

1. Single side return air with transition, to accommodate 20 x 25 x 1 in. air filter. Required to maintain proper air velocity.
2. Single side return with optional RAB Return Air Base
3. Bottom return air.
4. Return air from both sides.
5. Bottom and one side return air.

See Blower Performance Tables for additional information.

### OPTIONS

#### Horizontal Support Frame Kit

Provides support of unit in horizontal applications.

Consists of (2) 1 x 1-1/2 x 32-5/8 in. and (2) 1 x 3 x 53-7/8 in. painted heavy gauge cold rolled steel support channels with assembly and suspending holes.

Bolts and nuts furnished for field assembly.

Suspending rods must be field provided.

See Specifications table for catalog number.

#### RAB Return Air Base

Required with 60C and 60D models with air volumes over 1800 cfm in up-flow applications when only one side return is used.

"B" width base is not required but may also be used to provide clearance in certain applications (if required).

Cabinet is pre-painted steel to match the furnace.

See Dimension Drawing.

### 13 BLOWER

Multi-speed direct drive blower.

Statically and dynamically balanced.

Resiliently mounted.

Blower assembly easily removed for servicing.

Blower speeds are easily changed on the integrated furnace control board. See blower performance tables.

### COIL MATCH-UP

All furnaces exactly match C33 and CX34 cased, up-flow and CH33 cased, horizontal indoor coils with same letter designation in model number. No adaptor required. Engaging holes furnished on cabinet for alignment.

C33 uncased coils match furnaces without any overhang but require an optional adaptor base or field fabricated transition to match furnace opening. See C33 coil bulletin for additional information.

### FILTER (NOT FURNISHED)

Filter and provisions for external mounting must be field provided.

### OPTIONS

#### Air Filter and Rack Kit for Horizontal Return Air (End) Applications

Washable or vacuum cleanable polyurethane frame type filter and external end return air rack available for field installation.

Rack has filter door for easy filter servicing.

Flanges on rack allow easy duct connection.

See dimension drawing.

#### EZ Filter Base for Up-Flow Bottom Return Air Applications

Hinged door with thumbscrew for easy filter access.

Uses standard size filters (field provided).

#### Air Filter and Rack Kit for Up-Flow Side Return Air Applications - Not for use with RAB Return Air Base

Washable or vacuum cleanable polyurethane frame type filter and external side return air rack available for field installation.

Available in single and ten pack kits.

Rack has filter door for easy filter servicing.

Flanges on rack allow easy duct connection.

Field installs on either side of unit cabinet. See dimension drawing.

## SPECIFICATIONS

		Model No.	G40UH -24A-045	<sup>1</sup> G40UH -24A-070	G40UH -36A-070	G40UH -36B-090	G40UH -48B-090
		Low NO <sub>x</sub> Model No.	-24A-045X	---	-36A-070X	---	-48B-090X
<b>Gas Heating Performance</b>	Input - Btuh		44,000	66,000	66,000	88,000	88,000
	Output - Btuh		35,000	54,000	53,000	71,000	71,000
	<sup>2</sup> AFUE		80.0%	80.0%	80.0%	80.0%	80.0%
	High static (CSA) - in. w.g.		.50	.50	.50	.50	.50
	Temperature rise range - °F		35 - 65	40 - 70	40 - 70	40 - 70	40 - 70
	Gas Manifold Pressure (in. w.g.) - Nat. Gas LPG/Propane		3.5 10.0	3.5 10.0	3.5 10.0	3.5 10.0	3.5 10.0
<b>Connections</b>	Flue - in. (round)		4	4	4	4	4
	Gas pipe size IPS - in.		1/2	1/2	1/2	1/2	1/2
<b>Indoor Blower</b>	Wheel nom. dia. x width - in.		10 x 7	10 x 7	10 x 8	10 x 8	10 x 10
	Motor output - hp		1/5	1/5	1/3	1/3	1/2
	Tons of add-on cooling		1.5 - 2	1.5 - 2	2 - 3	2 - 3	3 - 4
<b>Shipping Data</b>	lbs. - 1 package		121	127	132	146	153
<b>Electrical characteristics</b>		120 volts - 60 hertz - 1 phase (less than 12 amps)					

## SPECIFICATIONS

		Model No.	<sup>1</sup> G40UH -36C-110	G40UH -48C-110	G40UH -60C-110	G40UH -48C-135	G40UH -60D-135	G40UH -60D-155
		Low NO <sub>x</sub> Model No.	---	---	-60C-110X	---	---	---
<b>Gas Heating Performance</b>	Input - Btuh		110,000	110,000	110,000	132,000	132,000	154,000
	Output - Btuh		88,000	87,000	88,000	106,000	107,000	122,000
	<sup>2</sup> AFUE		80.0%	80.0%	80.0%	80.0%	80.0%	80.0%
	High static (CSA) - in. w.g.		.50	.50	.50	.50	.50	.50
	Temperature rise range - °F		50 - 80	40 - 70	30 - 60	50 - 80	45 - 75	50 - 80
	Gas Manifold Pressure (in. w.g.) - Natural Gas LPG/Propane		3.5 10.0	3.5 10.0	3.5 10.0	3.5 10.0	3.5 10.0	3.5 10.0
<b>Connections</b>	Flue - in. (round)		4	4	4	<sup>3</sup> 4	<sup>3</sup> 4	<sup>3</sup> 4
	Gas pipe size IPS - in.		1/2	1/2	1/2	1/2	1/2	1/2
<b>Indoor Blower</b>	Wheel nom. dia. x width - in.		10 x 8	10 x 10	11-1/2 x 10	10 x 10	11-1/2 x 10	11-1/2 x 10
	Motor output - hp		1/3	1/2	1	1/2	1	1
	Tons of add-on cooling		2 - 3	3 - 4	4 - 5	2.5 - 4	4 - 5	4 - 5
<b>Shipping Data</b>	lbs. - 1 package		166	169	175	178	195	204
<b>Electrical characteristics</b>		120 volts - 60 hertz - 1 phase (less than 12 amps)						

NOTE - Filters and provisions for mounting are not furnished and must be field provided.

<sup>1</sup> Canada Only

<sup>2</sup> Annual Fuel Utilization Efficiency based on DOE test procedures and according to FTC labeling regulations. Isolated combustion system rating for non-weatherized furnaces.

<sup>3</sup> Flue connection on the unit is 4 in. diameter. Most applications will require 5 in. venting and field supplied 4 x 5 in. adaptor. See Venting Tables in the Installation Instructions for detailed information.

**OPTIONAL ACCESSORIES - MUST BE ORDERED EXTRA**

			"A" Width Models	"B" Width Models	"C" Width Models	"D" Width Models
<b>FILTER KITS</b>						
<sup>1</sup> Air Filter and Rack Kit	Horizontal (end)	Catalog No.	<b>87L95</b>	<b>87L96</b>	<b>87L97</b>	<b>87L98</b>
		Size of filter - in.	14 x 25 x 1	18 x 25 x 1	20 x 25 x 1	25x25 x 1
	Side Return	Single	<b>44J22</b>	<b>44J22</b>	<b>44J22</b>	<b>44J22</b>
		Ten Pack	<b>66K63</b>	<b>66K63</b>	<b>66K63</b>	<b>66K63</b>
		Size of filter - in.	16 x 25 x 1	16 x 25 x 1	16 x 25 x 1	16 x 25 x 1
EZ Filter Base Up-Flow Only	Catalog No. - Ship. Wt. - lbs.		<b>73P55 - 7</b>	<b>73P56 - 7</b>	<b>73P57 - 8</b>	<b>73P58 - 10</b>
	Size of field provided filter - in.		14 x 25 x 1	16 x 25 x 1	20 x 25 x 1	24 x 24 x 1
<b>CABINET ACCESSORIES</b>						
Horizontal Support Frame Kit - Horizontal Only			<b>56J18</b>	<b>56J18</b>	<b>56J18</b>	<b>56J18</b>
Return Air Base - Up-Flow Only			- - -	<b>98M60</b>	<b>98M58</b>	<b>98M59</b>
<b>CONTROLS</b>						
Twinning Kit			<b>15L38</b>	<b>15L38</b>	<b>15L38</b>	<b>15L38</b>
<b>VENTING</b>						
Vent Adaptor - 6 in. conn. up-flow applications only			<b>18M79</b>	<b>18M79</b>	<b>18M79</b>	<b>18M79</b>

<sup>1</sup> Cleanable polyurethane frame type filter.

**GAS HEAT ACCESSORIES**

Input	High Altitude Orifice Kit Natural Gas Only	High Altitude Pressure Switch Kit		LPG/Propane Kit	
	7501-10,000 ft.	0-7,500 ft.	7501-10,000 ft.	0-7500 ft.	7501-10,000 ft.
-all models	<b>44W51</b>	No Change	<b>56L32</b>	<b>25W20</b>	<b>25W21</b>

**FILTER AIR RESISTANCE**

For 1 Inch Cleanable Filter (Field Provided)

cfm	in. w.g.
0	0.00
200	0.01
400	0.03
600	0.04
800	0.06
1000	0.09
1200	0.12
1400	0.15
1600	0.19
1800	0.23
2000	0.27
2200	0.33
2400	0.38
2600	0.44

## 99% WINTER DESIGN TEMPERATURES FOR THE CONTIGUOUS UNITED STATES



This map is a necessarily generalized guide to temperatures in the contiguous United States. Temperatures shown for areas such as mountainous regions and large urban centers may not be accurate. The data used to develop this map was taken from the 1993 ASHRAE Fundamentals Handbook (Chapter 24, Table 1: Climate Conditions for the United States). Reprinted with permission from NFPA 54: *National Fuel Gas Code* ©1999, National Fire Protection Association, Quincy, MA 02269. This reprinted material is not the complete and official position of the National Fire Protection Association on the referenced subject, which is represented only by the standard in its entirety.

## INSTALLATION CLEARANCES

### UP-FLOW POSITION

Vent Type	Type "B1"	Type "C"
Sides	0 in. (0 mm)	<sup>1</sup> 0 in. (0 mm)
Rear	0 in. (0 mm)	0 in. (0 mm)
Top	1 in. (25 mm)	1 in. (25 mm)
Front	3 in. (76 mm)	3 in. (76 mm)
Front (service/alcove)	24 in. (610 mm)	24 in. (610 mm)
Floor	Combustible	Combustible
Flue	1 in. (25 mm)	6 in. (152 mm)

NOTE - Air for combustion must conform to the methods outlined in the National Fuel Gas Code (NFPA 54/ANSI-Z223.1) or the National Standard of Canada CAN/CSA-B149.1 "Natural Gas and Propane Installation Code".

NOTE - In the U.S. flue sizing must conform to the methods outlined in the current National Fuel Gas Code (NFPA 54/ANSI-Z223.1) or applicable provisions of local building codes. In Canada flue sizing must conform to the methods outlined in National Standard of Canada CAN/CSA-B149.1.

<sup>1</sup> Left side requires 4 in. if single wall vent is used on 14-1/2 in. cabinets, 2 in. on 17-1/2 in. cabinets.

### HORIZONTAL POSITION

Vent Type	Type "B1"	Type "C"
<sup>1</sup> Ends	<sup>1</sup> 2 in. (51 mm)	<sup>1</sup> 2 in. (51 mm)
Rear	0 in. (0 mm)	0 in. (0 mm)
<sup>1</sup> Top	<sup>1</sup> 0 in. (0 mm)	<sup>1</sup> 0 in. (0 mm)
Front	3 in. (76 mm)	3 in. (76 mm)
Front (service)	24 in. (610 mm)	24 in. (610 mm)
Floor	0 in. (0 mm)	0 in. (0 mm)
Flue	1 in. (25 mm)	6 in. (152 mm)

NOTE - Air for combustion must conform to the methods outlined in the National Fuel Gas Code (NFPA 54/ANSI-Z223.1) or the National Standard of Canada CAN/CSA-B149.1 "Natural Gas and Propane Installation Code".

NOTE - In the U.S. flue sizing must conform to the methods outlined in the current National Fuel Gas Code (NFPA 54/ANSI-Z223.1) or applicable provisions of local building codes. In Canada flue sizing must conform to the methods outlined in National Standard of Canada CAN/CSA-B149.1.

<sup>1</sup> Line contact installation permissible between jacket top or sides and building joists.

## DIMENSIONS - INCHES (MM) - UP-FLOW POSITION

<sup>1</sup> NOTE - 60C and 60D size units that require air volumes over 1800 cfm (850 L/s) must have one of the following:  
 1. Single side return air with transition, to accommodate 20 x 25 x 1 in. (508 x 635 x 25 mm) air filter. Required to maintain proper air velocity.  
 2. Single side return air with optional RAB Return Air Base  
 3. Bottom return air.  
 4. Return air from both sides.  
 5. Bottom and one side return air.  
 See Blower Performance Tables for additional information.

<sup>2</sup> Flue outlet may be horizontal but furnace must be vented vertically  
<sup>3</sup> Optional External Side Return Air Filter Kit is not for use with the optional RAB Return Air Base.

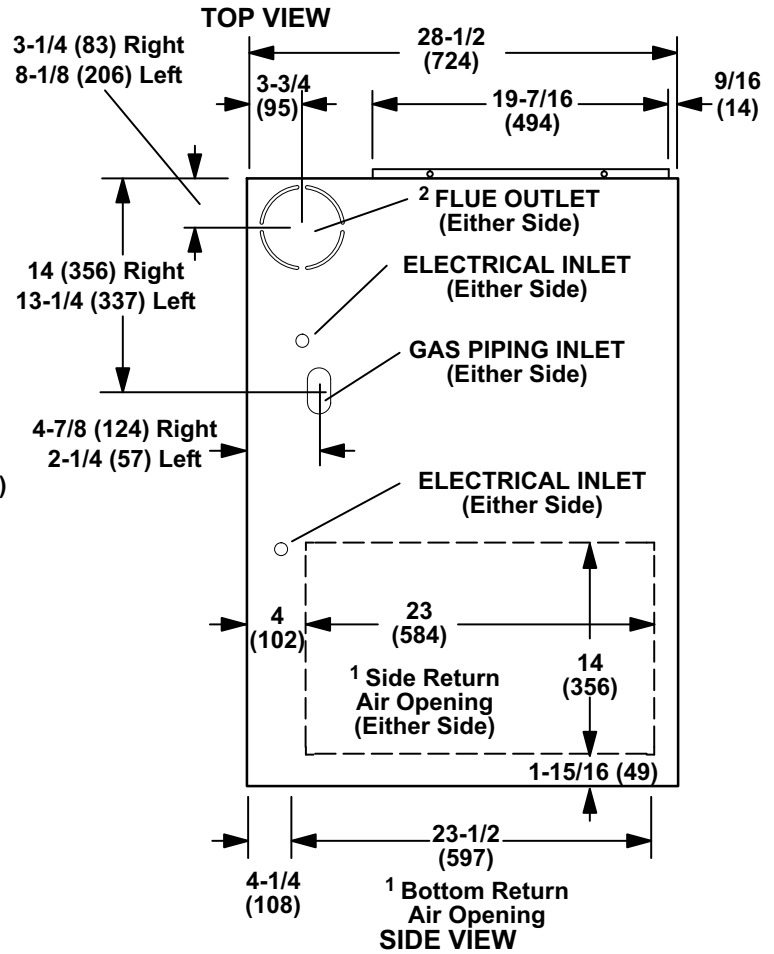
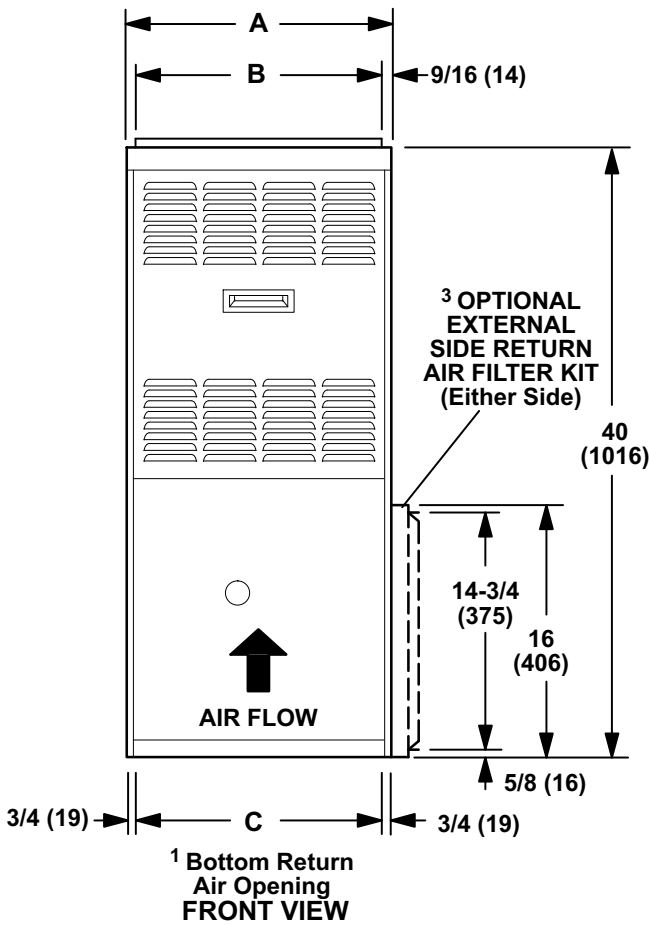
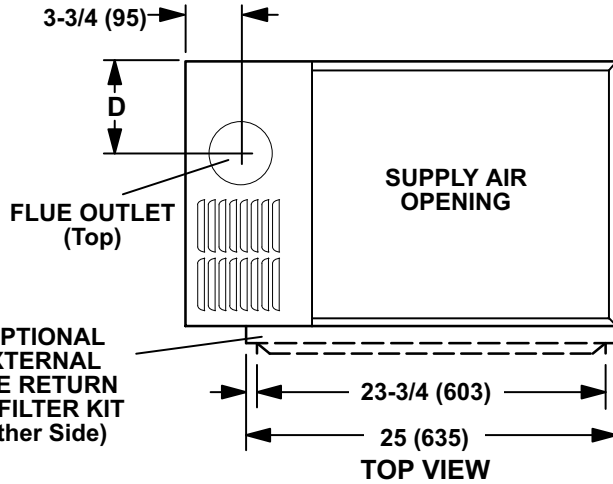

Model No.	A		B		C		D	
	in.	mm	in.	mm	in.	mm	in.	mm
G40UH-24A-045								
G40UH-24A-070	14-1/2	368	13-3/8	340	13	330	4-1/2	114
G40UH-36A-070								
G40UH-36B-090	17-1/2	446	16-3/8	416	16	406	6	152
G40UH-48B-090								
G40UH-36C-110								
G40UH-48C-110	21	533	19-7/8	505	19-1/2	495	7-3/4	197
G40UH-48C-135								
G40UH-60C-110								
G40UH-60D-135	24-1/2	622	23-3/8	546	23	584	9-1/2	241
G40UH-60D-155								



# DIMENSIONS - INCHES (MM) - HORIZONTAL POSITION

## LEFT-HAND AIR DISCHARGE

<sup>1</sup> Flue outlet may be from end but furnace must be vented vertically

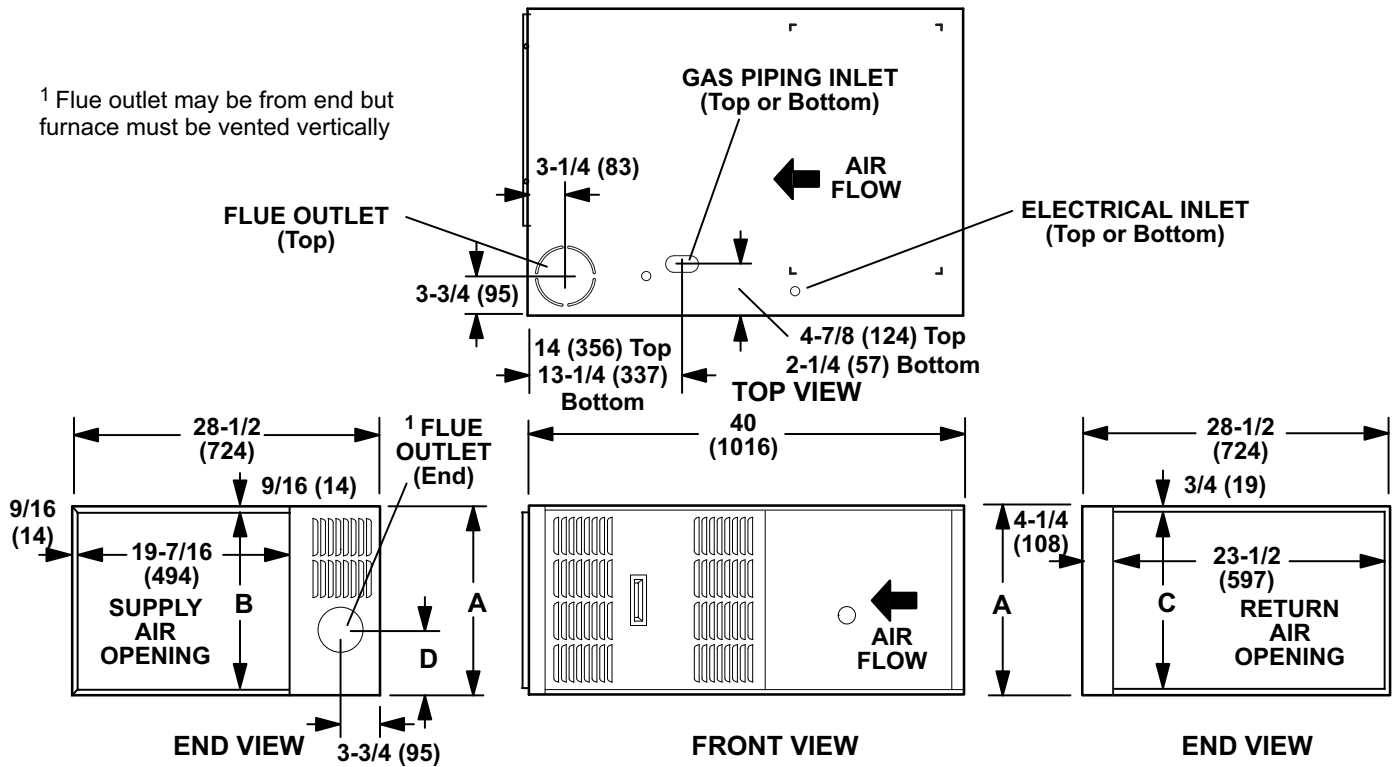

## RIGHT-HAND AIR DISCHARGE

<sup>1</sup> Flue outlet may be horizontal but furnace must be vented vertically

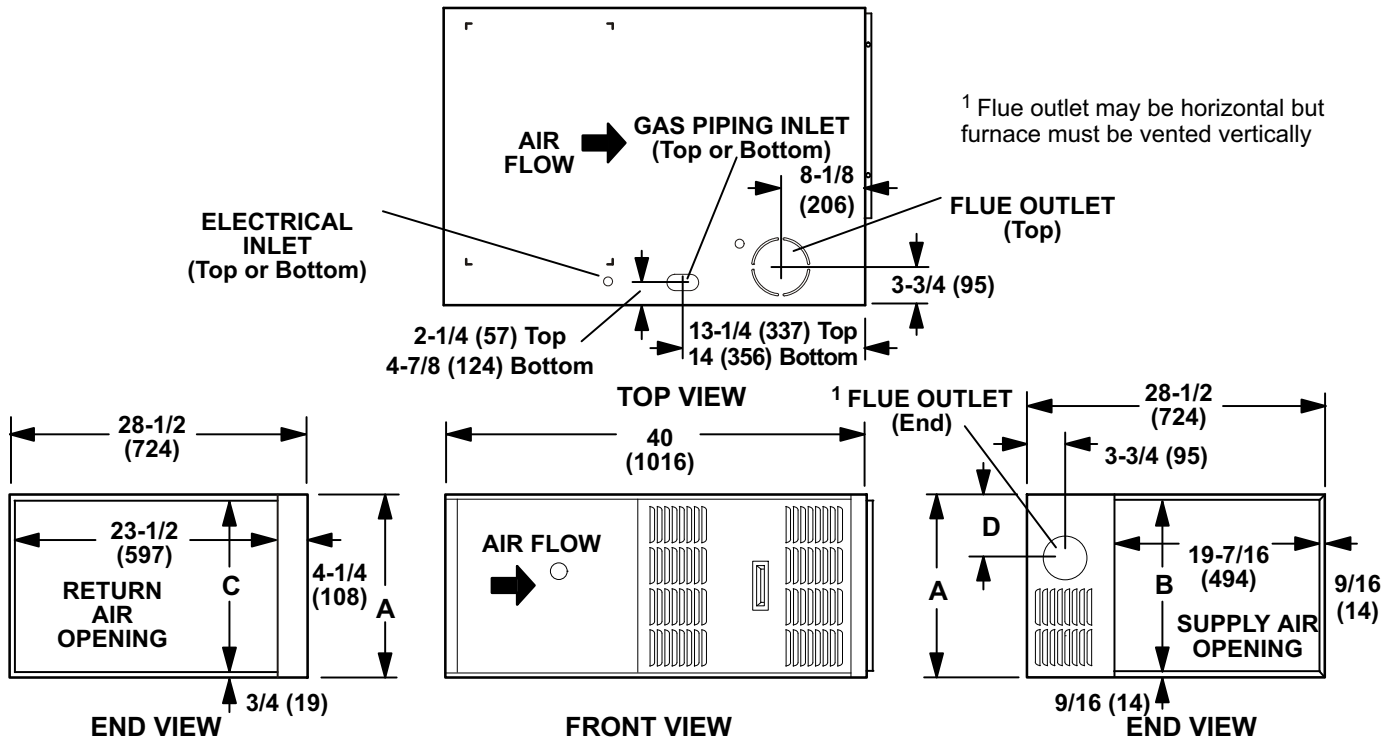

Model No.	A		B		C		D	
	in.	mm	in.	mm	in.	mm	in.	mm
G40UH-24A-045, G40UH-24A-070 G40UH-36A-070	14-1/2	368	13-3/8	340	13	330	4-1/2	114
G40UH-36B-090, G40UH-48B-090	17-1/2	446	16-3/8	416	16	406	6	152
G40UH-36C-110, G40UH-48C-110 G40UH-48C-135, G40UH-60C-110	21	533	19-7/8	504	19-1/2	495	7-3/4	197
G40UH-60D-135, G40UH-60D-155	24-1/2	622	23-3/8	546	23	584	9-1/2	241

## OPTIONAL ACCESSORY DIMENSIONS - INCHES (MM)

### HORIZONTAL FILTER KIT

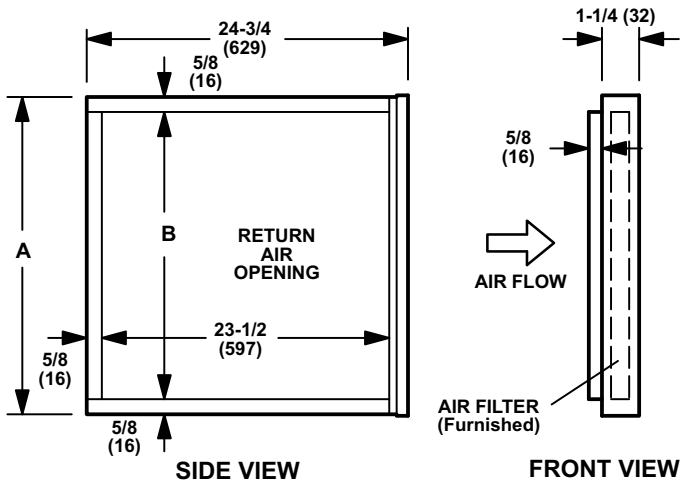

Catalog Number	A		B	
	inch	mm	inch	mm
87L95	14	356	12-3/4	324
87L96	18	457	16-3/4	425
87L97	21	533	18-3/4	476
87L98	25	635	23-3/4	603

### RAB RETURN AIR BASE (Up-Flow Applications Only) For use with B, C, and D size furnaces only

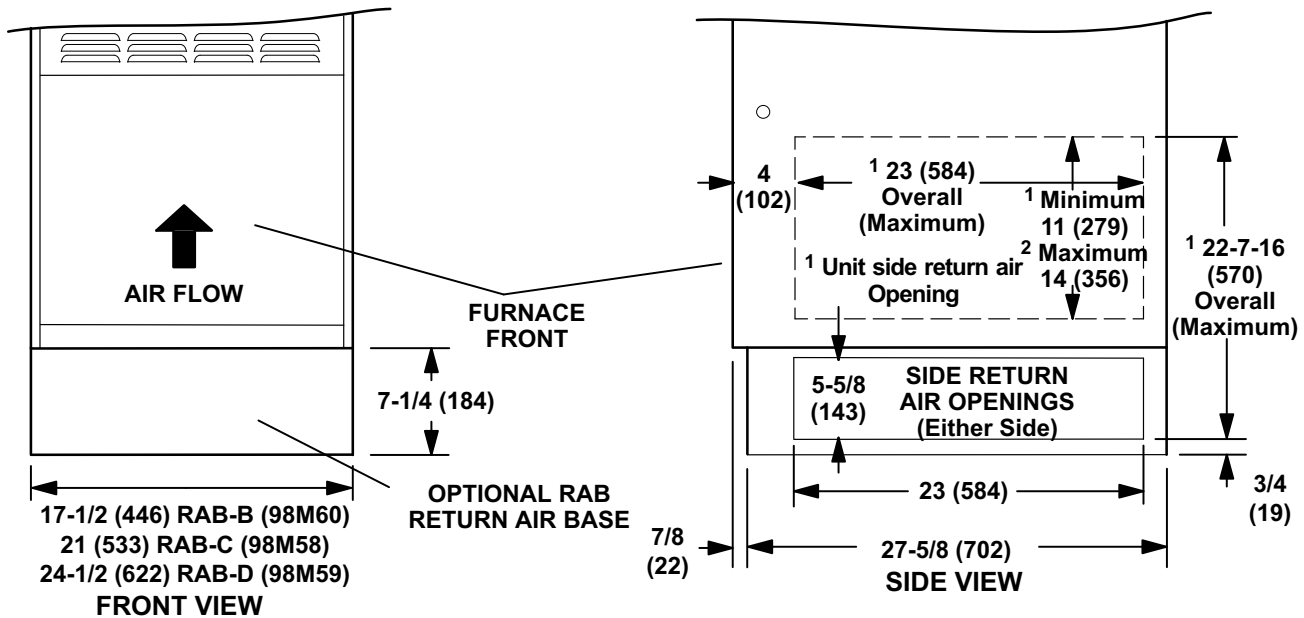

NOTE- Optional Side Return Air Filter Kits are not for use with RAB Return Air Base.

<sup>1</sup> Both the unit return air opening and the base return air opening must be covered by a single plenum or IAQ cabinet. Minimum unit side return air opening dimensions for units requiring 1800 cfm or more of air (W x H): 23 x 11 in. (584 x 279 mm). The opening can be cut as needed to accommodate plenum or IAQ cabinet while maintaining dimensions shown.

Side return air openings must be cut in the field. There are cutting guides stenciled on the cabinet for the side return air opening. The size of the opening must not extend beyond the markings on the furnace cabinet.

<sup>2</sup> To minimize pressure drop, the largest opening height possible (up to 14 inches) is preferred.

NOTE- Optional Side Return Air Filter Kits are not for use with RAB Return Air Base.

## DIMENSIONS - INCHES (MM) - FURNACE/COIL COMBINED DIMENSIONS

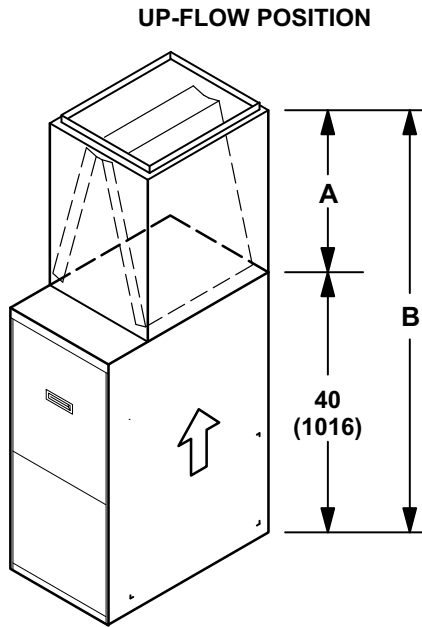

Model No	Cased				Uncased (CX34 - cased only)				
	A		B		A		B		
	in.	mm	in.	mm	in.	mm	in.	mm	
C33-18A	12-1/2	318	52-1/2	1334	9-3/4	248	49-3/4	1264	
CX34-19A-6F	C33-19A	16-1/2	419	56-1/2	1435	9-3/4	248	49-3/4	1264
C33-24A	16-1/2	419	56-1/2	1435	14	356	54	1372	
CX34-18/24A-6F	C33-24B C33-24C	16-1/2	419	56-1/2	1435	13-7/8	352	53-7/8	1368
CX34-18/24B-6F									
CX34-18/24C-6F									
CX34-25A-6F	C33-25A	18-1/2	470	58-1/2	1486	16-1/4	413	56-1/4	1429
CX34-25B-6F	C33-25B	18-1/2	470	58-1/2	1486	15-7/8	403	55-7/8	1419
CX34-30B-6F	C33-30B C33-30C	20-1/2	521	60-1/2	1537	17-3/4	451	59-3/4	1467
CX34-30C-6F									
CX34-30A-6F	C33-30A	20-1/2	521	60-1/2	1537	18	457	58	1473
CX34-31A-6F	C33-31A	22-1/2	572	62-1/2	1588	21-1/4	540	61-1/4	1556
CX34-31B-6F	C33-31B	22-1/2	572	62-1/2	1588	20-1/4	514	60-1/4	1530
CX34-36A-6F	C33-36A	24-1/2	622	64-1/2	1638	22-1/8	562	62-1/8	1578
CX34-36B-6F	C33-36B	24-1/2	622	64-1/2	1638	21-7/8	556	61-7/8	1572
CX34-36C-6F	C33-36C	24-1/2	622	64-1/2	1638	21-1/4	540	61-1/4	1556
CX34-38A-6F	C33-38A	24-1/2	622	64-1/2	1638	22-1/4	565	62-1/4	1581
CX34-38B-6F	C33-38B	24-1/2	622	64-1/2	1638	22	559	62	1575
CX34-42B-6F	C33-42B	24-1/2	622	64-1/2	1638	21-7/8	556	61-7/8	1572
CX34-43B-6F	C33-43B	27-1/2	699	67-1/2	1715	26-1/4	667	66-1/4	1683
CX34-43C-6F	C33-43C	27-1/2	699	67-1/2	1715	25-3/4	654	65-3/4	1670
	C33-44C	24-1/2	622	64-1/2	1638	21-1/2	546	61-1/2	1562
CX34-44/48B-6F	C33-48B	24-1/2	622	64-1/2	1638	22-1/8	562	62-1/8	1578
CX34-44/48C-6F	C33-48C	24-1/2	622	64-1/2	1638	21-1/2	546	61-1/2	1562
CX34-49C-6F	C33-49C	30-1/2	775	70-1/2	1791	28-1/2	724	68-1/2	1740
CX34-50/60C-6F	C33-50/60C	27-1/2	699	67-1/2	1715	24-3/4	629	64-3/4	1645
CX34-60D-6F	C33-60D	25-1/2	648	65-1/2	1664	24-3/4	629	64-3/4	1645
CX34-62C-6F	C33-62C	31-1/2	800	71-1/2	1816	30-5/8	778	70-5/8	1793
CX34-62D-6F	C33-62D	29-1/2	749	69-1/2	1765	28-3/4	730	68-3/4	1746

Model Number		A		B	
		in.	mm	in.	mm
CH33-18A-2F		21-1/2	546	61-1/2	1562
CH33-24/30A-2F	CH33-42B-2F	26-1/2	673	66-1/2	1689
CH33-36A-2F	CH33-48C-2F				
CH33-36B-2F	CH33-60D-2F				
CH33-36C-2F					
CH33-44/48B-2F	CH33-62D-2F	31-1/2	800	71-1/2	1816
CH33-50/60C-2F					

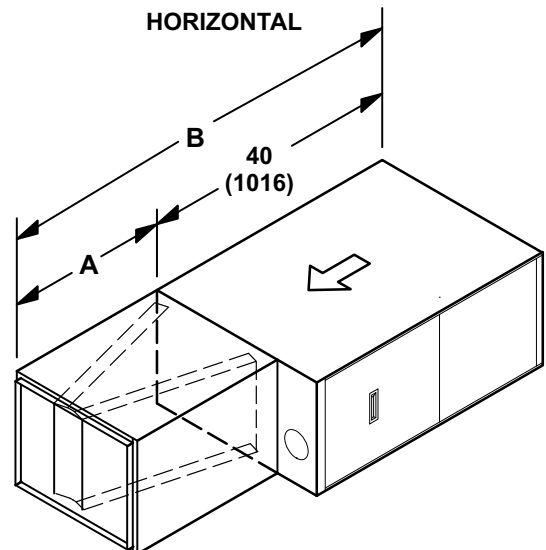

## BLOWER/WATTS DATA

### G40UH-24A-045 PERFORMANCE

External Static Pressure in. w.g.	Air Volume / Watts at Various Blower Speeds					
	High		Medium		Low	
	cfm	Watts	cfm	Watts	cfm	Watts
0.00	1090	460	905	390	725	300
0.05	1080	450	900	390	720	300
0.10	1065	445	895	385	710	295
0.15	1050	435	895	380	700	290
0.20	1030	425	890	375	690	290
0.25	1015	415	875	370	680	285
0.30	995	410	860	365	665	280
0.40	960	395	840	350	650	270
0.50	910	380	795	335	610	260
0.60	840	355	750	315	540	245
0.70	770	340	665	295	490	235
0.80	660	315	555	275	420	225
0.90	560	295	480	260	355	210

### G40UH-24A-070 PERFORMANCE

External Static Pressure in. w.g.	Air Volume / Watts at Various Blower Speeds					
	High		Medium		Low	
	cfm	Watts	cfm	Watts	cfm	Watts
0.00	1075	445	905	375	730	290
0.05	1070	445	900	375	725	290
0.10	1065	440	895	370	720	285
0.15	1060	435	890	365	715	285
0.20	1055	430	885	360	710	280
0.25	1045	425	880	360	700	280
0.30	1030	415	875	355	690	270
0.40	1010	400	860	350	675	270
0.50	975	390	840	340	660	265
0.60	940	375	805	325	640	255
0.70	890	360	755	305	605	240
0.80	830	340	700	285	565	225
0.90	765	305	640	265	515	205

NOTE - All air data is measured external to unit with 1 in. cleanable filter (not furnished - field provided) in place. Also see Filter Air Resistance table.

### G40UH-36A-070 PERFORMANCE

External Static Pressure in. w.g.	Air Volume / Watts at Various Blower Speeds							
	High		Medium-High		Medium-Low		Low	
	cfm	Watts	cfm	Watts	cfm	Watts	cfm	Watts
0.00	1500	705	1290	565	985	455	830	375
0.05	1475	695	1275	555	980	445	820	365
0.10	1450	680	1255	545	970	440	810	360
0.15	1425	670	1240	535	965	430	805	355
0.20	1400	655	1225	525	955	425	795	350
0.25	1370	645	1205	510	945	415	790	345
0.30	1340	630	1180	500	930	405	780	335
0.40	1285	610	1140	475	900	390	745	325
0.50	1215	580	1080	450	865	375	705	310
0.60	1150	560	1015	430	810	355	655	290
0.70	1060	535	940	405	730	330	585	270
0.80	955	515	800	370	655	305	480	260
0.90	785	475	605	325	585	270	410	255

### G40UH-36B-090 PERFORMANCE

External Static Pressure in. w.g.	Air Volume / Watts at Various Blower Speeds							
	High		Medium-High		Medium-Low		Low	
	cfm	Watts	cfm	Watts	cfm	Watts	cfm	Watts
0.00	1500	720	1255	595	1040	460	900	370
0.05	1485	705	1250	580	1040	450	895	365
0.10	1465	685	1240	570	1035	445	890	360
0.15	1450	675	1235	555	1035	440	885	355
0.20	1435	660	1225	545	1030	435	880	350
0.25	1420	645	1215	530	1025	425	875	345
0.30	1400	630	1200	520	1020	415	870	340
0.40	1345	595	1170	495	1000	400	855	330
0.50	1300	575	1135	475	965	380	830	300
0.60	1235	545	1080	445	930	360	780	290
0.70	1165	510	1020	415	870	340	740	280
0.80	1080	480	940	385	800	315	670	260
0.90	985	445	840	355	710	290	600	245

NOTE - All air data is measured external to unit with 1 in. cleanable filter (not furnished - field provided) in place. Also see Filter Air Resistance table.

### G40UH-36C-110 PERFORMANCE

External Static Pressure in. w.g.	Air Volume / Watts at Various Blower Speeds							
	High		Medium-High		Medium-Low		Low	
	cfm	Watts	cfm	Watts	cfm	Watts	cfm	Watts
0.00	1555	715	1335	575	1085	460	925	365
0.05	1540	705	1330	555	1080	450	920	360
0.10	1525	690	1320	545	1075	440	915	355
0.15	1510	680	1310	535	1070	430	910	350
0.20	1490	670	1295	525	1065	420	900	340
0.25	1465	655	1280	510	1060	415	890	335
0.30	1440	645	1260	495	1050	405	880	330
0.40	1385	615	1230	485	1030	390	865	320
0.50	1320	590	1190	460	995	375	835	300
0.60	1260	570	1135	430	960	355	815	295
0.70	1190	545	1075	410	915	345	775	285
0.80	1090	515	970	385	860	325	760	280
0.90	975	485	880	360	790	305	705	275

### G40UH-48B-090 PERFORMANCE

External Static Pressure in. w.g.	Air Volume / Watts at Various Blower Speeds							
	High		Medium-High		Medium-Low		Low	
	cfm	Watts	cfm	Watts	cfm	Watts	cfm	Watts
0.00	1970	790	1810	735	1585	670	1340	565
0.05	1940	780	1785	715	1580	650	1335	555
0.10	1915	765	1760	695	1570	630	1325	540
0.15	1880	745	1730	660	1560	615	1325	530
0.20	1840	730	1700	620	1545	600	1320	520
0.25	1805	715	1670	625	1520	585	1310	510
0.30	1765	695	1640	625	1490	565	1295	500
0.40	1695	670	1570	595	1440	540	1260	480
0.50	1600	635	1490	560	1360	505	1195	450
0.60	1505	600	1400	530	1285	480	1140	425
0.70	1395	565	1265	485	1170	440	990	380
0.80	1250	520	1100	445	975	390	905	355
0.90	1005	460	870	385	900	365	810	325

NOTE - All air data is measured external to unit with 1 in. cleanable filter (not furnished - field provided) in place. Also see Filter Air Resistance table.

## BLOWER/WATTS DATA

NOTE - All air data is measured external to unit with 1 in. cleanable filter (not furnished - field provided) in place. Also see Filter Air Resistance table.

### G40UH-48C-110 PERFORMANCE

External Static Pressure in. w.g.	Air Volume / Watts at Various Blower Speeds							
	High		Medium-High		Medium-Low		Low	
	cfm	Watts	cfm	Watts	cfm	Watts	cfm	Watts
0.00	2015	895	1620	780	1340	640	1150	525
0.05	1990	870	1615	760	1340	640	1150	525
0.10	1965	850	1610	745	1340	640	1150	525
0.15	1930	825	1605	725	1335	630	1150	525
0.20	1895	805	1600	710	1335	615	1150	525
0.25	1860	785	1590	695	1330	605	1150	520
0.30	1820	765	1580	675	1330	590	1145	515
0.40	1740	725	1530	635	1320	560	1140	490
0.50	1665	695	1475	600	1285	525	1120	470
0.60	1575	650	1405	555	1230	490	1075	445
0.70	1475	610	1310	515	1165	470	1015	415
0.80	1350	560	1210	485	1080	430	930	380
0.90	1210	520	1070	430	870	365	740	325

### G40UH-48C-135 PERFORMANCE

External Static Pressure in. w.g.	Air Volume / Watts at Various Blower Speeds							
	High		Medium-High		Medium-Low		Low	
	cfm	Watts	cfm	Watts	cfm	Watts	cfm	Watts
0.00	2075	820	1800	710	1425	570	1115	435
0.05	2035	805	1785	695	1425	560	1120	435
0.10	1990	790	1765	675	1420	545	1125	430
0.15	1950	765	1740	660	1410	535	1125	425
0.20	1905	745	1715	645	1405	525	1120	420
0.25	1865	730	1680	625	1390	515	1115	410
0.30	1825	715	1650	610	1375	505	1105	405
0.40	1740	680	1585	580	1355	485	1090	390
0.50	1640	645	1495	545	1300	455	1050	370
0.60	1540	615	1420	515	1225	430	1000	355
0.70	1420	575	1310	475	1140	400	935	330
0.80	1260	520	1155	425	1025	365	865	315
0.90	1125	495	1010	385	880	330	750	285

### G40UH-60C-110 PERFORMANCE

External Static Pressure in. w.g.	Air Volume / Watts at Different Blower Speeds															
	Bottom Return Air, Side Return Air with Optional RAB Return Air Base, Return Air from Both Sides or Return Air from Bottom and One Side.						Single Side Return Air - Air volumes in bold require field fabricated transition to accommodate 20 x 25 x 1 in. air filter in order to maintain proper air velocity.									
	High		Medium-High		Medium-Low		Low		High		Medium-High		Medium-Low		Low	
	cfm	Watts	cfm	Watts	cfm	Watts	cfm	Watts	cfm	Watts	cfm	Watts	cfm	Watts	cfm	Watts
0.00	2655	1407	2370	1063	2085	894	1665	679	<b>2430</b>	<b>1309</b>	<b>2245</b>	<b>1006</b>	<b>1910</b>	<b>843</b>	1635	686
0.10	2580	1376	2350	1043	2065	875	1650	667	<b>2355</b>	<b>1277</b>	<b>2190</b>	<b>978</b>	<b>1905</b>	<b>817</b>	1620	677
0.20	2500	1346	2305	1012	2045	849	1645	662	<b>2280</b>	<b>1242</b>	<b>2140</b>	<b>950</b>	<b>1885</b>	<b>797</b>	1610	667
0.30	2410	1305	2230	978	2010	820	1640	649	<b>2205</b>	<b>1218</b>	<b>2075</b>	<b>924</b>	<b>1860</b>	<b>782</b>	1605	655
0.40	2320	1270	2165	947	1940	786	1625	634	<b>2130</b>	<b>1189</b>	<b>2005</b>	<b>905</b>	<b>1815</b>	<b>752</b>	1595	636
0.50	2225	1235	2090	914	1895	763	1610	622	<b>2045</b>	<b>1159</b>	<b>1920</b>	<b>864</b>	1750	726	1565	619
0.60	2130	1205	2000	880	1840	740	1570	603	<b>1955</b>	<b>1132</b>	<b>1850</b>	<b>840</b>	1700	705	1525	605
0.70	2030	1155	1915	851	1760	709	1535	590	<b>1860</b>	<b>1105</b>	1760	817	1610	674	1475	582
0.80	1925	1123	1820	823	1670	681	1475	566	1755	1067	1670	789	1540	654	1395	560
0.90	1795	1078	1690	788	1560	655	1395	537	1645	1033	1575	763	1445	627	1325	540

### G40UH-60D-135 PERFORMANCE

External Static Pressure in. w.g.	Air Volume / Watts at Different Blower Speeds															
	Bottom Return Air, Side Return Air with Optional RAB Return Air Base, Return Air from Both Sides or Return Air from Bottom and One Side.						Single Side Return Air - Air volumes in bold require field fabricated transition to accommodate 20 x 25 x 1 in. air filter in order to maintain proper air velocity.									
	High		Medium-High		Medium-Low		Low		High		Medium-High		Medium-Low		Low	
	cfm	Watts	cfm	Watts	cfm	Watts	cfm	Watts	cfm	Watts	cfm	Watts	cfm	Watts	cfm	Watts
0.00	2715	1407	2255	1070	1910	850	1660	674	<b>2455</b>	<b>1336</b>	<b>2170</b>	<b>1019</b>	<b>1850</b>	<b>829</b>	1555	673
0.10	2640	1403	2250	1030	1900	834	1645	668	<b>2380</b>	<b>1299</b>	<b>2140</b>	<b>974</b>	<b>1840</b>	<b>812</b>	1550	664
0.20	2540	1355	2245	1006	1890	821	1630	665	<b>2305</b>	<b>1266</b>	<b>2105</b>	<b>947</b>	<b>1830</b>	<b>791</b>	1545	656
0.30	2480	1319	2200	975	1890	781	1625	656	<b>2235</b>	<b>1234</b>	<b>2045</b>	<b>914</b>	<b>1820</b>	<b>774</b>	1540	642
0.40	2390	1282	2155	940	1885	775	1615	642	<b>2160</b>	<b>1240</b>	<b>1985</b>	<b>886</b>	<b>1800</b>	<b>755</b>	1540	628
0.50	2320	1251	2085	904	1860	758	1605	631	<b>2065</b>	<b>1170</b>	<b>1925</b>	<b>863</b>	1745	726	1535	614
0.60	2205	1210	2020	876	1815	731	1595	611	<b>1990</b>	<b>1146</b>	<b>1870</b>	<b>844</b>	1700	706	1505	599
0.70	2080	1161	1935	839	1760	707	1545	588	<b>1895</b>	<b>1111</b>	1775	808	1655	689	1465	573
0.80	2010	1122	1855	810	1690	679	1495	568	<b>1805</b>	<b>1074</b>	1680	779	1565	656	1425	562
0.90	1880	1071	1755	781	1585	646	1430	545	1695	1042	1590	752	1480	630	1335	533

## BLOWER/WATTS DATA

NOTE - All air data is measured external to unit with 1 in. cleanable filter (not furnished - field provided) in place. Also see Filter Air Resistance table.

### G40UH-60D-155 PERFORMANCE

External Static Pressure in. w.g.	Air Volume / Watts at Different Blower Speeds															
	Bottom Return Air, Side Return Air with Optional RAB Return Air Base, Return Air from Both Sides or Return Air from Bottom and One Side.								Single Side Return Air - Air volumes in bold require field fabricated transition to accommodate 20 x 25 x 1 in. air filter in order to maintain proper air velocity.							
	High		Medium-High		Medium-Low		Low		High		Medium-High		Medium-Low		Low	
	cfm	Watts	cfm	Watts	cfm	Watts	cfm	Watts	cfm	Watts	cfm	Watts	cfm	Watts	cfm	Watts
0.00	2670	1386	2325	1048	1970	857	1700	706	<b>2410</b>	<b>1282</b>	<b>2175</b>	<b>987</b>	<b>1870</b>	<b>833</b>	1620	675
0.10	2580	1342	2320	1045	1965	842	1690	696	<b>2335</b>	<b>1257</b>	<b>2140</b>	<b>956</b>	<b>1860</b>	<b>810</b>	1610	667
0.20	2510	1311	2255	985	1960	817	1640	662	<b>2255</b>	<b>1225</b>	<b>2085</b>	<b>918</b>	<b>1855</b>	<b>788</b>	1605	658
0.30	2425	1277	2210	953	1955	803	1635	649	<b>2205</b>	<b>1200</b>	<b>2025</b>	<b>896</b>	<b>1830</b>	<b>764</b>	1600	647
0.40	2345	1246	2150	922	1925	778	1630	633	<b>2120</b>	<b>1164</b>	<b>1975</b>	<b>874</b>	1795	742	1595	628
0.50	2255	1217	2095	897	1890	752	1615	618	<b>2040</b>	<b>1131</b>	<b>1905</b>	<b>847</b>	1745	731	1575	618
0.60	2170	1182	2010	863	1840	733	1590	605	<b>1955</b>	<b>1103</b>	<b>1835</b>	<b>820</b>	1695	698	1540	601
0.70	2090	1139	1925	833	1785	708	1550	588	<b>1870</b>	<b>1069</b>	1760	792	1635	673	1465	568
0.80	1895	1106	1840	806	1710	683	1500	571	1770	1041	1670	763	1560	646	1415	548
0.90	1855	1064	1740	776	1620	655	1430	551	1660	1006	1585	740	1480	629	1345	527



## REVISIONS

Sections	Description of Change
All	Deleted G40UH-36A-045 and G40UH-48B-070
Optional Accessories Table/ Gas Heating Accessories	Updated High Altitude Pressure Switch Kits, updated High Altitude Orifice Kits
Dimensions	Changed height on cased, CX34-19A, CX34-25A/B, CX34-31A/B, CX34-43B/C, CX34-62C



Energy  
Performance  
Rendement  
Énergétique

VÉRIFIÉ



**LENNOX**

Visit us at [www.lennox.com](http://www.lennox.com)

For the latest technical information, [www.lennox.com](http://www.lennox.com)

Contact us at 1-800-4-LENNOX

NOTE - Due to Lennox' ongoing commitment to quality, Specifications, Ratings and Dimensions subject to change without notice and without incurring liability. Improper installation, adjustment, alteration, service or maintenance can cause property damage or personal injury. Installation and service must be performed by a qualified installer and servicing agency.

©2008 Lennox Industries Inc.