



GAS FURNACES

G61MPV

ELITE® SERIES

Multi-Position - Two-Stage Heat - Variable Speed Blower

Bulletin No. 210506
 December 2008
 Supersedes April 2008



AFUE - up to 95.0%
Input - 44,000 to 132,000 Btuh
Nominal Add-on Cooling - 2 to 5 Tons

MODEL NUMBER IDENTIFICATION

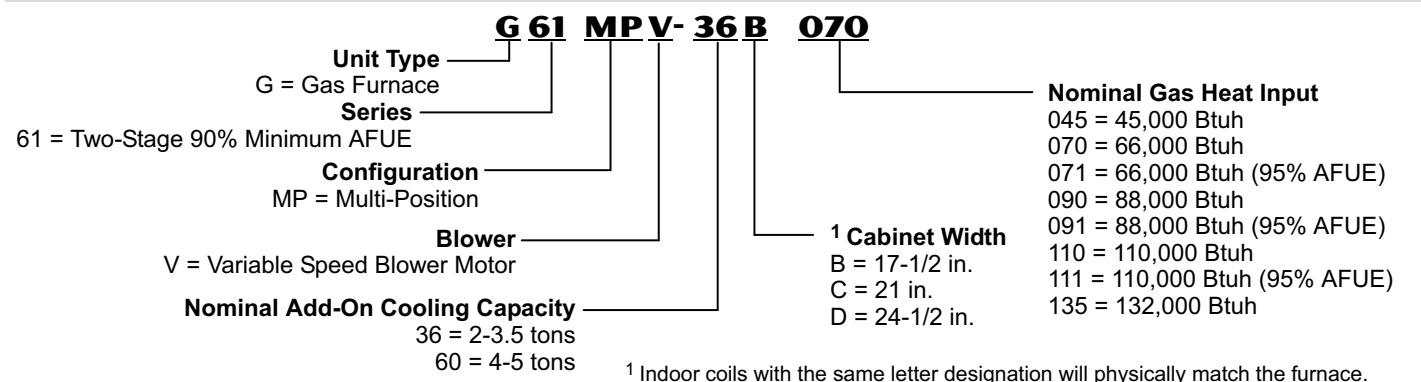

FEATURES

CONTENTS

Blower Data	Pages 16-34
Dimensions	Pages 10-15
Exhaust Pipe Venting Information	Page 8
Features and Options	Pages 2-5
Installation Clearances	Page 9
Model Number Identification	Page 1
Optional Accessories Selection Table	Page 7
Specifications	Page 6

WARRANTY

Duralok Plus® Aluminized Steel Heat Exchanger - Limited lifetime warranty in residential applications (twenty year transferrable), ten years in non-residential applications.

All Other Covered Components - Limited five year warranty in residential applications, one year in non-residential applications.

APPROVALS

Units certified by CSA International and ratings are certified by GAMA.

Units tested and rated according to US DOE test procedures and FTC labeling regulations.

Blower data from unit tests conducted in Lennox Laboratory air test chamber.

Approved by the California Energy Commission and meet California Seasonal Efficiency requirements and California Nitrogen Oxides (NOx) Standards.

ENERGY STAR® certified units are designed to use less energy, help save money on utility bills, and help protect the environment.

ISO 9001 Registered Manufacturing Quality System.

APPLICATIONS

Input capacities of 44,000, 66,000, 88,000, 110,000, and 132,000 Btuh.

Energy efficiency (AFUE) up of 95.0% in all four installation configurations.

Compact cabinet for up-flow, down-flow, horizontal-left or horizontal-right applications without any internal modifications to the unit.

Variable speed blower ideal for zoning applications.

Lennox add-on indoor coils, high-efficiency air cleaners and humidifiers can easily be added to furnace.

Shipped factory assembled with all controls installed and wired.

Each unit factory test operated to ensure proper operation.

Zoning Applications

Units may be used with certain zoning systems. Zone control panel must be able to interface and communicate with the variable speed blower motor in the unit. Lennox Harmony III™ Zone Control Panel has this capability.

DIRECT VENT / NON-DIRECT VENT

Furnace can be installed in either Direct Vent or Non-Direct applications. In Direct Vent applications, combustion air is supplied from outdoors and flue gases are discharged outdoors. In Non-Direct Vent applications, combustion air is supplied from indoors and flue gases are discharged outdoors.

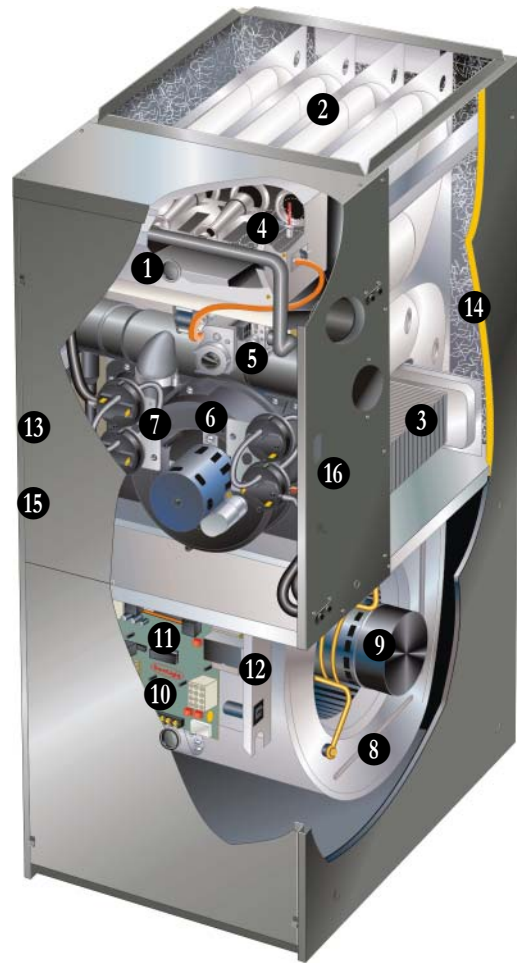

OPTIONS

Termination Kits

Facilitates installation of combustion air intake pipe and flue exhaust pipe.

Refer to venting table in this bulletin to determine pipe size needed and proper termination kit required.

See Specifications table and dimension drawings.

Termination Kit - Concentric - Direct Vent Applications Only

2 or 3 inch kit contains concentric termination assembly, reducer bushing and 45 degree elbow.

2 inch kit for -045-070-071 models contains an outdoor exhaust accelerator.

Kit requires single hole penetration of roof or wall for installation.

Roof Termination Flashing Kit is available for use with 2 inch Kits.

CSA certified.

Termination Kits - Wall Assembly

Close Couple (US Only) - Direct Vent Applications Only

2 or 3 inch kit consists of close-couple, side-by-side PVC piping with galvanized steel wall cover plate for sealing and isolating piping penetration of the wall.

Piping spacing and length is sized for proper wall installations. CSA certified.

Close Couple WTK (Canada Only) - Direct Vent Applications Only

2 or 3 inch kit contains one insulated faceplate, one insulated exhaust pipe, elbow and fittings.

FEATURES

DIRECT VENT / NON-DIRECT VENT - CONTINUED

Wall Ring - Direct or Non-Direct Vent

2 inch kit contains 2 stainless steel outside seal caps, 2 galvanized steel inside seal caps, 4 seal rings for the caps and 18 inch insulation sleeve for sealing and isolating intake and exhaust piping penetration of wall.

Maintain a maximum of 6 inches between the inlet and outlet openings in the installation of the pipes.

Roof Termination Flashing Kit - Direct or Non-Direct Vent

2 or 3 inch kit contains two neoprene rubber roof flashings for vertical venting through a roof.

Vent pipe and insulation not furnished. Each kit contains enough parts for two non-direct vent installations.

Also available for use with 2 inch (use 3 inch flashing) Concentric Vent Termination Kits used in vertical venting rooftop applications.

HEATING SYSTEM

1 SilentComfort™ Technology

Patent pending burner sound enclosure and extra cabinet insulation reduces operating sound levels.

2 Lennox Duralok Plus® Heat Exchanger Assembly

Lennox developed heat exchanger assembly consists of primary heat exchanger and secondary condenser coil assembly.

Main 3-pass crimped seam design clamshell type heat exchanger.

Constructed of heavy-gauge, aluminized steel.

Designed for normal expansion and contraction with maximum efficiency and minimum resistance to air flow.

3 Secondary heat exchanger condenser coil constructed of aluminum fins fitted to stainless steel tubes.

Coil is factory tested for leaks.

Condensate drain header box assembly located on front of coil.

Compact size of complete heat exchanger assembly permits low overall design of furnace cabinet.

All components mounted in a heavy-gauge steel frame.

Heat exchanger assembly has been laboratory life cycle tested.

Lennox Designed Header Box

Header box on end of condenser coil collects flue condensate for disposal through condensate collars.

Hose connects the header box drains to the condensate collars.

The condensate collars are located on each side of the cabinet for easy field installation of condensate drain trap.

Only one collar is used, the remainder stay plugged.

Condensate drain trap is included with the unit for field installation.

Lennox Designed Flue Condensate Trap Assembly

Condensate trap assembly is mounted outside the conditioned air stream.

Assembly can be mounted on either side of cabinet in up-flow and down-flow applications. Assembly is mounted on the bottom of the cabinet in horizontal applications. See Installation Instructions.

Connection can be made with field provided 1/2 in. PVC pipe, 3/4 in. PVC coupling, or 1-1/4 in. OD x 1 in. ID vinyl tubing with hose clamp.

Optional Condensate Trap Alternate Location Kit allows condensate drain to be installed on the opposite side of the furnace from the exhaust venting (up-flow applications only). Easy to clean and winterize.

4 Inshot Burners

Aluminized steel inshot burners provide efficient, trouble-free operation.

Burner venturi mixes air and gas in correct proportion for proper combustion.

Burner assembly is removable from the unit as a single component for ease of service.

5 Two-Stage Gas Control Valve

24 volt redundant combination two stage gas control valve combines manual shut off valve (On-Off), automatic electric valve (dual) and gas pressure regulation into a compact combination control.

Flame Rollout Switch

Manual reset switches are factory installed on burner box. Switch provides protection from abnormal operating conditions.

SureLight® Hot Surface Ignitor

Tough, reliable, long-life, trouble-free performance.

Tungsten heater element sandwiched between two plates of silicon nitride.

Cemented to steatite block for protection against current leakage.

Ignition leads constructed of nickel plated copper enclosed in high temperature Teflon insulation for dependable operation. No electrical noise.

6 Combustion Air Inducer

PSC, heavy-duty blower prepurges heat exchanger and safely vents flue products.

7 Pressure switches prove blower operation before allowing gas valve to open.

Operates only during heating cycle.

Limit Controls

Automatic reset, primary and secondary limits are accurately located.

Primary limit factory installed on vestibule panel on all units, secondary limit factory installed on blower housing.

OPTIONS

High Altitude Orifice Kit - Natural Gas Only

Required for -071-091-111 natural gas models for proper unit operation at altitude of 2000 to 10,000 feet.

Required on all natural gas models for proper unit operation at altitudes of 7500 to 10,000 feet.

See Gas Heat Accessory table for details.

Proper orifice for LPG/Propane models is included with LPG/Propane Conversion Kit.

High Altitude Pressure Switch Kit

Required on certain units for proper unit operation on installations above 2,000 ft.

Order two per unit.

LPG/Propane Conversion Kit

Required for field changeover from natural gas to LPG/Propane.

Natural Gas Conversion Kit

Required for field changeover from LPG/Propane to natural gas.

FEATURES

BLOWER

Variable Speed Direct Drive Blower

Each blower assembly statically and dynamically balanced.

Change in blower speed is easily accomplished by simple DIP switch change on SureLight® Integrated Furnace Two Stage / Variable Speed Blower Control.

See Blower Performance tables.

- 8 Blower assembly easily removed for servicing

9 Variable Speed Blower Motor

Variable speed motor maintains specified air volume from 0 though 0.80 in. w.g. static range.

Variable speed operation is achieved by the use of an ECM (Electronically Commutated Motor) motor.

Motor is controlled by SureLight® Integrated Furnace Two Stage / Variable Speed Blower Control.

Motor is resiliently mounted. When furnaces are used with Harmony Zone III™ Control System, blower motor operates from predetermined minimum - maximum air volumes to satisfy zone requirements.

CONTROLS

10 SureLight® Integrated Two Stage / Variable Speed Blower Control

Solid-state board contains all necessary controls and relays to operate furnace.

Combustion air inducer is controlled by board. Prior to ignition, a pre-purge cycle for 15 seconds is initiated. After the main burners are turned off, a post-purge cycle for 5 seconds is run.

Adaptive technology of ignition control board continuously monitors and adjusts the ignitor power to operate at minimum ignitor temperature required for ignition, prolonging ignitor life.

Electronic flame sensor assures safe, reliable operation. Should flame fail to ignite, flame sensor will initiate 4 re-attempts at ignition before locking out unit operation for 60 minutes.

Watchguard type circuit automatically resets ignition controls after one hour of continuous thermostat demand after unit lockout, eliminating nuisance calls for service.

Jumper settings for 1 or 2 stage thermostat operation. Two selectable 2nd stage recognition times (10 and 15 minutes) are available on the board when the furnace is used with a single stage thermostat. When used with a two stage thermostat, furnace will only initiate second stage operation with a second stage thermostat demand.

Two LED's indicate heating status and aid in troubleshooting.

- 11 Two accessory terminals furnished for additional power supply requirements for 120 volt (less than 1 amp) power humidifiers and powered air cleaners.

Two blower speeds - second stage heat and second stage cool (with four air volume selections for each) are selected by DIP switches on board. Heat speed can be adjusted to optimize discharge temperature. Cool speed can be adjusted to correct optional cooling capacity. See Blower Performance tables.

First stage blower speed is a percentage of 2nd stage speed. The ADJUST switch (DIP) allows normal (NORM), 10% higher (+ plus) or 10% lower (- minus) motor speed selection within HEAT and COOL speeds selected for fine tuning air volume.

DELAY switch (DIP) allows one of four de-humidification profiles during cooling mode.

Profile A - Motor runs at 50% for 30 seconds, then at 82% for 7-1/2 minutes, then at 100% (if needed) until demand is satisfied. Once demand is met, motor runs at 50% for 30 seconds, then ramps down to stop.

Profile B - Motor runs at 82% for 7-1/2 minutes and then at 100% (if needed) until demand is satisfied. Once demand is met, motor ramps down to stop.

Profile C - Motor runs at 100% until demand is satisfied. Once demand is met, motor runs at 100% for 60 seconds, then ramps down to stop.

Profile D - Motor runs at 100% until demand is satisfied. Once demand is met, motor ramps down to stop.

In heat mode, blower on time is fixed at 45 seconds, blower off time is adjustable from 60, 90, 120 and 180 seconds (factory setting - 90 seconds).

Control has four status lights (CFM, ON/OFF, HTG BLOWER, HI/LOW) to assist in servicing.

For air-conditioning applications, blower on time is 2 seconds following thermostat demand for cooling.

Board controls evaporator humidity by controlling blower and compressor speed on two stage outdoor units when used with Lennox SignatureStat.

Control is factory installed in the unit control box.

12 24 Volt Transformer

Furnished and factory installed in control box.

40VA transformer has circuit breaker wired in series.

13 Field Wiring Make-up Box

Furnished for line voltage wiring.

Factory installed internally on left side of furnace.

Box may be installed internally or externally on either side of furnace.

OPTIONS

ComfortSense™ 7000 Touchscreen Thermostat

Electronic 7-day, universal, multi-stage, programmable, touchscreen thermostat.

4 Heat/2 Cool.

Auto-changeover.

Controls humidity during cooling mode.

Offers enhanced capabilities including

humidification / dehumidification / dewpoint measurement and control, Humiditrol® control, and equipment maintenance reminders.

Easy-to-use, menu driven thermostat with a back-lit, LCD touchscreen.

Remote outdoor temperature sensor (optional) allows the thermostat to display outdoor temperature. Required in dual fuel and Humiditrol® applications.

See the ComfortSense™ 7000 Engineering Handbook bulletin in the Controls section for more information.

Thermostat

See Thermostat bulletins in Controls section and Lennox Price Book for a complete list of thermostats.



FEATURES

CABINET

Low-profile, narrow width cabinet allows easy installation in up-flow, down-flow or horizontal applications. Heavy-gauge, cold rolled steel construction. Pre-painted cabinet finish.

Flanges provided on supply air opening for ease of plenum connection or alignment with indoor coil.

- 14 Fully insulated cabinet with foil faced insulation on sides and back of heating compartment and mat faced insulation in blower compartment. Complete service access.
- 15 Tool-less latches on blower and burner doors assure positive lock. Safety interlock switch automatically shuts off power to unit when blower compartment access door is removed.
- 16 Gas piping and electrical inlets are provided in both sides of cabinet.

Return Air Entry:

For bottom/end return-air entry for up-flow/horizontal applications, remove furnished bottom seal panel from cabinet.

For side return-air entry (up-flow applications only), corners are marked on either side of cabinet for return air cut-outs. On furnaces with side return air and condensate trap on the same side of the cabinet, a field fabricated transition or RAB is required when using an IAQ product higher than 14-3/16 in. installed next to the unit and serviced from the front. IAQ products higher than 20 in. require a field fabricated transition. See dimension drawings.

NOTE - 60C and 60D size units that require air volumes over 1800 cfm (850 L/s) must have one of the following:

1. Single side return air with transition, to accommodate 20 x 25 x 1 in. cleanable air filter, required to maintain proper air velocity.
2. Single side return air with optional RAB Return Air Base.
3. Bottom return air.
4. Return air from both sides.
5. Bottom and one side return air.

See Blower Performance Tables for additional information.

Coil Match-up

All furnaces exactly match C33 and CX34 cased up-flow indoor coils and CH33 horizontal indoor coils with same letter designation in model number. No adaptor required. Engaging holes furnished on cabinet for alignment.

C33 uncased coils match furnaces without any overhang but require an optional adaptor base or field fabricated transition to match furnace opening. See C33 coil bulletin for additional information.

All furnaces exactly match CR33 cased, down-flow indoor coils with adaptor rails, furnished with coil.

OPTIONS

Condensate Drain Heat Cable Kits

Self-limiting wattage heat cable prevents condensate drain from freezing in unconditioned areas.

Available in 6, 24 or 50 ft. lengths.

Heat Cable Tape:

66 ft. length, 1/2 in. wide fiberglass.

60 ft. length, 2 in. wide aluminum foil.

Condensate Trap Alternate Location Kit

Allows condensate drain to be installed on the opposite side of the furnace from the exhaust venting (up-flow applications only).

Down-Flow Additive Base

Required for heating only units installed on combustible floors.

Not required in add-on cooling applications.

See Dimension Drawing.

Horizontal Support Frame Kit

Provides support of unit in horizontal applications.

Consists of (2) 1 x 1-1/2 x 32-5/8 in. and (2) 1 x 3 x 53-7/8 in. painted, heavy-gauge cold rolled steel support channels with assembly and suspending holes. Bolts and nuts furnished for field assembly. Suspending rods must be field provided.

RAB Return Air Base

On furnaces with side return air and condensate trap on the same side of the cabinet, a field fabricated transition or RAB is required when using an IAQ product higher than 14-3/16 in. installed next to the unit and serviced from the front. IAQ products higher than 20 in. require a field fabricated transition.

Must be used for 60C and 60D models with air volumes over 1800 cfm in up-flow applications when only one side return is required.

Cabinet is pre-painted steel to match the furnace.

See Dimension Drawing.

INDOOR AIR QUALITY

See Indoor Air Quality section and Lennox Price Book for a complete list of indoor air quality products (air purification systems, high efficiency air filters and filter cabinets, UV lights, humidifiers, fresh air ventilation system and heat/energy recovery systems).

FILTER (NOT FURNISHED)

Filter and provisions for external mounting must be field provided.

OPTIONS

Air Filter and Rack Kit for Horizontal Return Air (End) Applications

Washable or vacuum cleanable polyurethane frame type filter and external end return air rack available for field installation.

Rack has filter door for easy filter servicing.

Flanges on rack allow easy duct connection.

See dimension drawing.

Air Filter and Rack Kit for Side Return Air Applications (Not for use with RAB Return Air Base)

Washable or vacuum cleanable polyurethane frame type filter and external side return air rack available for field installation.

Available in single and ten pack kits.

Rack has filter door for easy filter servicing.

Flanges on rack allow easy duct connection.

Field installs on either side of unit cabinet.

See dimension drawing.

EZ Filter Base for Bottom Return Air Applications

Hinged door with thumbscrew for easy filter access.

Uses standard size filters (field provided).

SPECIFICATIONS

Gas Heating Performance		Model No.	G61MPV -36B-045	G61MPV -36B-070	G61MPV -36B-071	G61MPV -36C-090	
High Fire	Input - Btuh		44,000	66,000	66,000	88,000	
	Output - Btuh		39,000	61,000	62,000	79,000	
	Temperature rise range - °F		20 - 50	45 - 75	45 - 75	70 - 100	
	Gas Manifold Pressure (in. w.g.) Natural Gas / LPG/Propane		3.5 / 10.0	3.5 / 10.0	3.5 / 10.0	3.5 / 10.0	
	Low Fire	Input - Btuh		30,000	45,000	45,000	60,000
		Output - Btuh		29,000	43,000	43,000	57,000
		Temperature rise range - °F		10 - 40	25 - 55	20 - 50	35 - 65
		Gas Manifold Pressure (in. w.g.) Natural Gas / LPG/Propane		1.7 / 4.9	1.7 / 4.9	1.7 / 4.9	1.7 / 4.9
		¹ AFUE		94.1%	94.1%	95.0%	94.3%
		High static (CSA) - in. w.g.		.80	.80	.80	.80
Connections in.	Intake / Exhaust Pipe (PVC)		2 / 2	2 / 2	2 / 2	2 / 2	
	Condensate Drain Trap (PVC pipe) - i.d.		1/2	1/2	1/2	1/2	
	with field supplied (PVC coupling) - o.d.		3/4	3/4	3/4	3/4	
	hose with hose clamp - i.d. x o.d.		1 x 1-1/4	1 x 1-1/4	1 x 1-1/4	1 x 1-1/4	
	Gas pipe size IPS		1/2	1/2	1/2	1/2	
Indoor Blower	Wheel nominal diameter x width - in.		10 x 8	10 x 8	10 x 8	10 x 10	
	Motor output - hp		1/2	1/2	1/2	1/2	
	Tons (kW) of add-on cooling		2 - 3	2 - 3.5	2 - 3.5	2 - 3.5	
	Air volume range - cfm		610 - 1420	625 - 1395	625 - 1395	600 - 1395	
Shipping Data	lbs. - 1 package		128	151	151	170	
Electrical characteristics			120 volts - 60 hertz - 1 phase (less than 12 amps)				

NOTE - Filters and provisions for mounting are not furnished and must be field provided.

¹ Annual Fuel Utilization Efficiency based on DOE test procedures and according to FTC labeling regulations. Isolated combustion system rating for non-weatherized furnaces.

SPECIFICATIONS

Gas Heating Performance		Model No.	G61MPV -60C-090	G61MPV -60C-091	G61MPV -60C-110	G61MPV -60C-111	G61MPV -60D-135	
High Fire	Input - Btuh		88,000	88,000	110,000	110,000	132,000	
	Output - Btuh		82,000	84,000	99,000	103,000	122,000	
	Temperature rise range - °F		40 - 70	40 - 70	50 - 80	50 - 80	65 - 95	
	Gas Manifold Pressure (in. w.g.) Natural Gas / LPG/Propane		3.5 / 10.0	3.5 / 10.0	3.5 / 10.0	3.5 / 10.0	3.5 / 10.0	
	Low Fire	Input - Btuh		60,000	60,000	75,000	75,000	90,000
		Output - Btuh		55,000	58,000	72,000	72,000	87,000
		Temperature rise range - °F		20 - 50	20 - 50	30 - 60	25 - 55	40 - 70
		Gas Manifold Pressure (in. w.g.) Natural Gas / LPG/Propane		1.7 / 4.9	1.7 / 4.9	1.7 / 4.9	1.7 / 4.9	1.7 / 4.9
		¹ AFUE		94.6%	95.0%	94.3%	95.0%	94.6%
		High static (CSA) - in. w.g.		.80	.80	.80	.80	.80
Connections in.	Intake / Exhaust Pipe (PVC)		2 / 2	2 / 2	2 / 2	2 / 2	3 / 3	
	Condensate Drain Trap (PVC pipe) - i.d.		1/2	1/2	1/2	1/2	1/2	
	with field supplied (PVC coupling) - o.d.		3/4	3/4	3/4	3/4	3/4	
	hose with hose clamp - i.d. x o.d.		1-1/4 x 1	1-1/4 x 1	1-1/4 x 1	1-1/4 x 1	1-1/4 x 1	
	Gas pipe size IPS		1/2	1/2	1/2	1/2	1/2	
Indoor Blower	Wheel nominal diameter x width - in.		11-1/2 x 10	11-1/2 x 10	11-1/2 x 10	11-1/2 x 10	11-1/2 x 10	
	Motor output - hp		1	1	1	1	1	
	Tons (kW) of add-on cooling		3.5 - 5	3.5 - 5	3.5 - 5	3.5 - 5	3.5 - 5	
	Air volume range - cfm		895 - 2215	895 - 2215	740 - 2210	740 - 2210	915 - 2190	
Shipping Data	lbs. - 1 package		180	180	188	188	207	
Electrical characteristics			120 volts - 60 hertz - 1 phase (less than 12 amps)					

NOTE - Filters and provisions for mounting are not furnished and must be field provided.

¹ Annual Fuel Utilization Efficiency based on DOE test procedures and according to FTC labeling regulations. Isolated combustion system rating for non-weatherized furnaces.

OPTIONAL ACCESSORIES - MUST BE ORDERED EXTRA

			"B" Width Models	"C" Width Models	"D" Width Models
FILTER KITS					
¹ Air Filter and Rack Kit	Horizontal (end)	Size of filter - in.	87L96 - 18 x 25 x 1	87L97 - 20 x 25 x 1	87L98 - 25 x 25 x 1
	Side Return	Single	44J22	44J22	44J22
		Ten Pack	66K63	66K63	66K63
		Size of filter - in.	16 x 25 x 1	16 x 25 x 1	16 x 25 x 1
EZ Filter Base	Catalog No. - Ship. Wt. - lbs.		73P56 - 7	73P57 - 8	73P58 - 10
	Size of field provided filter - in.		16 x 25 x 1	20 x 25 x 1	24 x 24 x 1

CABINET ACCESSORIES

Down-Flow Additive Base	11M60	11M61	11M62
Horizontal Support Frame Kit	56J18	56J18	56J18
Return Air Base	98M60	98M58	98M59

CONDENSATE DRAIN KITS

Condensate Drain Heat Cable	6 ft.	26K68	26K68	26K68
	24 ft.	26K69	26K69	26K69
	50 ft.	26K70	26K70	26K70
Heat Cable Tape	Fiberglass - 1/2 in. x 66 ft.	36G53	36G53	36G53
	Aluminum foil - 2 in. x 60 ft.	16P89	16P89	16P89
Condensate Trap Alternate Location Kit - Up-Flow Only		76M20	76M20	76M20

CONTROLS

ComfortSense™ 7000 Thermostat	Y0349	Y0349	Y0349
Remote Outdoor Temperature Sensor (for dual fuel and Humiditrol)	X2658	X2658	X2658

TERMINATION KITS - See Installation Instructions for specific venting information.

Termination Kits - Direct or Non-Direct Vent Applications Only	Concentric	US - 2 in.	71M80	69M29	---
		3 in.	---	60L46	60L46
		Canada - 2 in.	44W92	44W92	---
	Wall - Close Couple	3 in.	---	44W93	44W93
		US - 2 in.	22G44	---	---
		3 in.	44J40	44J40	44J40
Wall - Close Couple WTK	Canada - 2 in.	30G28	---	---	
	3 in.	81J20	81J20	81J20	
² Termination Kits - Direct or Non-Direct Vent	Roof	2 in.	15F75	15F75	---
	Wall Ring Kit	2 in.	15F74	15F74	³ 15F74
² Roof Termination Flashing Kit - Direct or Non-Direct Vent - Contains two flashings.			44J41	44J41	44J41

¹ Cleanable polyurethane frame type filter.

² Kits contain enough parts for two, non-direct vent installations.

³ Non-direct vent only.

GAS HEAT ACCESSORIES

Input	High Altitude Orifice Kit Natural Gas Only	High Altitude Pressure Switch Kit ORDER TWO EACH				LPG/Propane Kit		LPG/Propane to Natural Gas Kit	
	7501-10,000 ft.	2000-4500 ft.	4501-7500 ft.	7501-10,000 ft.	0-7500 ft.	7501-10,000 ft.	0-7500 ft.	¹ 7501-10,000 ft.	
-045	44W51	---	---	---	44W48	44W50	44W49	44W49 + 44W51	
-070	44W51	---	---	56M23	44W48	44W50	44W49	44W49 + 44W51	
-071	44W51	75M22	75M22	56M21	44W48	44W50	44W49	44W49 + 44W51	
-090	44W51	---	75M22	56M21	44W48	44W50	44W49	44W49 + 44W51	
-091	47M82	26W85	26W85	26W86	44W48	44W50	44W49	44W49 + 47M82	
-110	44W51	---	56M23	75M22	44W48	44W50	44W49	44W49 + 44W51	
-111	47M82	56M22	56M22	56M23	44W48	44W50	44W49	44W49 + 47M82	
-135	44W51	---	56M93	56M93	44W48	44W50	44W49	44W49 + 44W51	

¹ High Altitude Orifice Kit is required and must be ordered separately for applications from 7501 to 10,000 ft.

EXHAUST PIPE VENTING TABLE (For altitudes of 0-10,000 ft.)

Vent Pipe Diameter	¹ Maximum Equivalent Vent Length - ft.							
	G61MPV -36B-045	G61MPV -36B-070	G61MPV -36B-071	G61MPV -36C-090 -60C-090	G61MPV -60C-091	² G61MPV -60C-110	² G61MPV -60C-111	³ G61MPV -60D-135
2 in.	59	59	⁴ 59	26	⁴ 26	not allowed	not allowed	not allowed
2-1/2 in.	65	65	⁴ 65	42	⁴ 42	32	⁴ 32	not allowed
3 in.	77	78	⁴ 78	72	⁴ 72	72	⁴ 72	⁴ 61 (0-4500 ft.) ⁴ 46 (4501 - 10,000 ft.)
4 in.	234	214	214	204	204	179	179	160

NOTE - Minimum Equivalent Vent Pipe length is 15 feet (4.6 m).

¹ Maximum Equivalent Vent Length" permitted is defined as "Total Length (linear feet) of vent pipe, plus equivalent length (ft.) of fittings, plus equivalent length (ft.) of termination".

² 110 and 111 models installed in up-flow or down-flow applications must have the supplied 90° street ell installed directly into the unit flue collar. The street ell must be included in the elbow count.

³ 135 models installed in up-flow or down-flow applications must have 3 in. to 2 in. reducing elbow (supplied) installed directly into the flue collar. Reducing ell must be included in elbow count.

⁴ 90° elbows must be limited to sweep type elbows.

VENTING NOTES — One 90° elbow is equivalent to 5 feet of straight vent pipe.

Two 45° elbows are equal to one 90° elbow.

One 45° elbow is equivalent to 2.5 feet of straight vent pipe.

Wall and roof termination (non-concentric) exhaust pipe must terminate with reducer to improve exhaust velocity away from intake piping.

045, 070 and 071 - 2, 2-1/2, 3 or 4 in. - terminate with 1-1/2 in. pipe

090 and 091 - 2, 2-1/2, 3 or 4 in. - terminate with 2 in. pipe

110 and 111 - 2-1/2, 3 or 4 in. - terminate with 2 in. pipe

135 - 3 or 4 in. - terminate with 2 in. pipe

TERMINATION KITS - EQUIVALENT VENT LENGTHS

Input Size	Vent Pipe Diameter in.	Vent Pipe Equivalent Length - ft.								
		Concentric Kits				Close Couple Kits		Wall Ring Kit	Outdoor Exhaust Accelerator (Diameter X Length) For use with Close Couple and Wall Ring Kits	
		2 in.		3 in.	2 in.	3 in.	2 in.	1-1/2 x 12 in.	2 x 12 in.	
		⁴ 71M80	⁴ 44W92	69M29	60L46 44W93	22G44 30G28 (WTK)	44J40 81J20 (WTK)	15F74	Field Provided	
-045	2	12	12			4	¹ 4	4	4	
	2-1/2	15	15	not allowed	not allowed	5	¹ 5	5	5	not allowed
	3	21	21			7	¹ 7	7	7	
	4	42	42			14	¹ 14	14	14	
-070 -071	2	12	12			4	¹ 4	4	4	
	2-1/2	15	15	not allowed	not allowed	5	¹ 5	5	5	not allowed
	3	24	24			8	¹ 8	8	8	
	4	42	42			14	¹ 14	14	14	
-090 -091	2		3	3	3		1	² 1		1
	2-1/2	not allowed	6	6	6	not allowed	2	² 2	not allowed	2
	3		6	6	6		2	² 2		2
	4		12	12	12		4	² 4		4
-110 -111	2		3	3	3		1	² 1		1
	2-1/2	not allowed	6	6	6	not allowed	2	³ 2	not allowed	2
	3		6	6	6		2	³ 2		2
	4		12	12	12		4	³ 4		4
-135	3		not allowed		15	not allowed	6	³ 6	not allowed	6
	4				25		10	³ 10		10

¹ Requires field provided 1-1/2 in. outdoor exhaust accelerator.

² Requires field provided 2 in. outdoor exhaust accelerator.

³ For use only in non-direct vent applications, when snow riser is not required. Requires field provided 2 in. outdoor exhaust accelerator.

⁴ Outdoor exhaust accelerator is furnished in 71M80 and 44W92 kits and is required when used with -045-070-071 models. The accelerator is not used with -090-091-110-111-135 models.

INSTALLATION CONFIGURATIONS

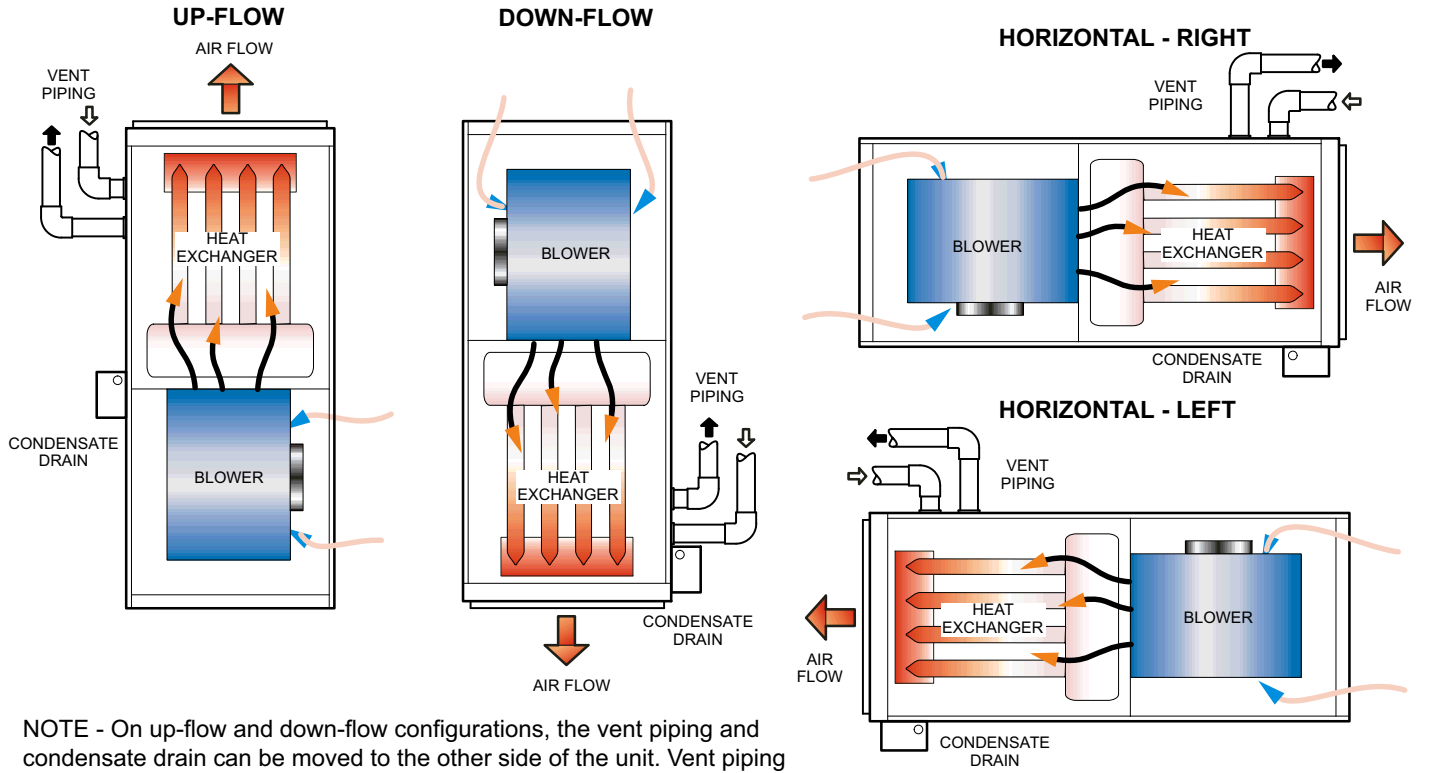

NOTE - On up-flow and down-flow configurations, the vent piping and condensate drain can be moved to the other side of the unit. Vent piping and drain must be installed on the same side of the unit with each other unless optional Condensate Trap Alternate Location Kit (up-flow only) is used. On horizontal installations the drain must be located at the bottom and the vent piping at the top.

INSTALLATION CLEARANCES

Sides	1 0 inches (0 mm)
Rear	0 inches (0 mm)
Top/Plenum	1 inch (25 mm)
Front	0 inches (0 mm)
Front (service/alcove)	24 inches (610 mm)
Floor	2 Combustible

NOTE - Air for combustion must conform to the methods outlined in the National Fuel Gas Code (NFPA 54/ANSI-Z223.1) or the National Standard of Canada CAN/CSA-B149.1 "Natural Gas and Propane Installation Code".

NOTE - In the U.S. flue sizing must conform to the methods outlined in the current National Fuel Gas Code (NFPA 54/ANSI-Z223.1) or applicable provisions of local building codes. In Canada flue sizing must conform to the methods outlined in National Standard of Canada CAN/CSA-B149.1.

¹ Allow proper clearances to accommodate condensate trap and vent pipe installation.

² Do not install the furnace directly on carpeting, tile, or other combustible materials other than wood flooring.

DIMENSIONS - INCHES (MM) UP-FLOW POSITION SHOWN

¹ NOTE - 60C and 60D size units that require air volumes over 1800 cfm (850 L/s) must have one of the following:

- a. Single side return air with transition, to accommodate 20 x 25 x 1 in. (508 x 635 x 25 mm) air filter. Required to maintain proper air velocity.
- b. Single side return air with optional RAB Return Air Base
- c. Bottom return air.
- d. Return air from both sides.
- e. Bottom and one side return air.

See Blower Performance Tables for additional information.

² Optional External Side Return Air Filter Kit (Up-Flow Only) is not for use with the optional RAB Return Air Base.

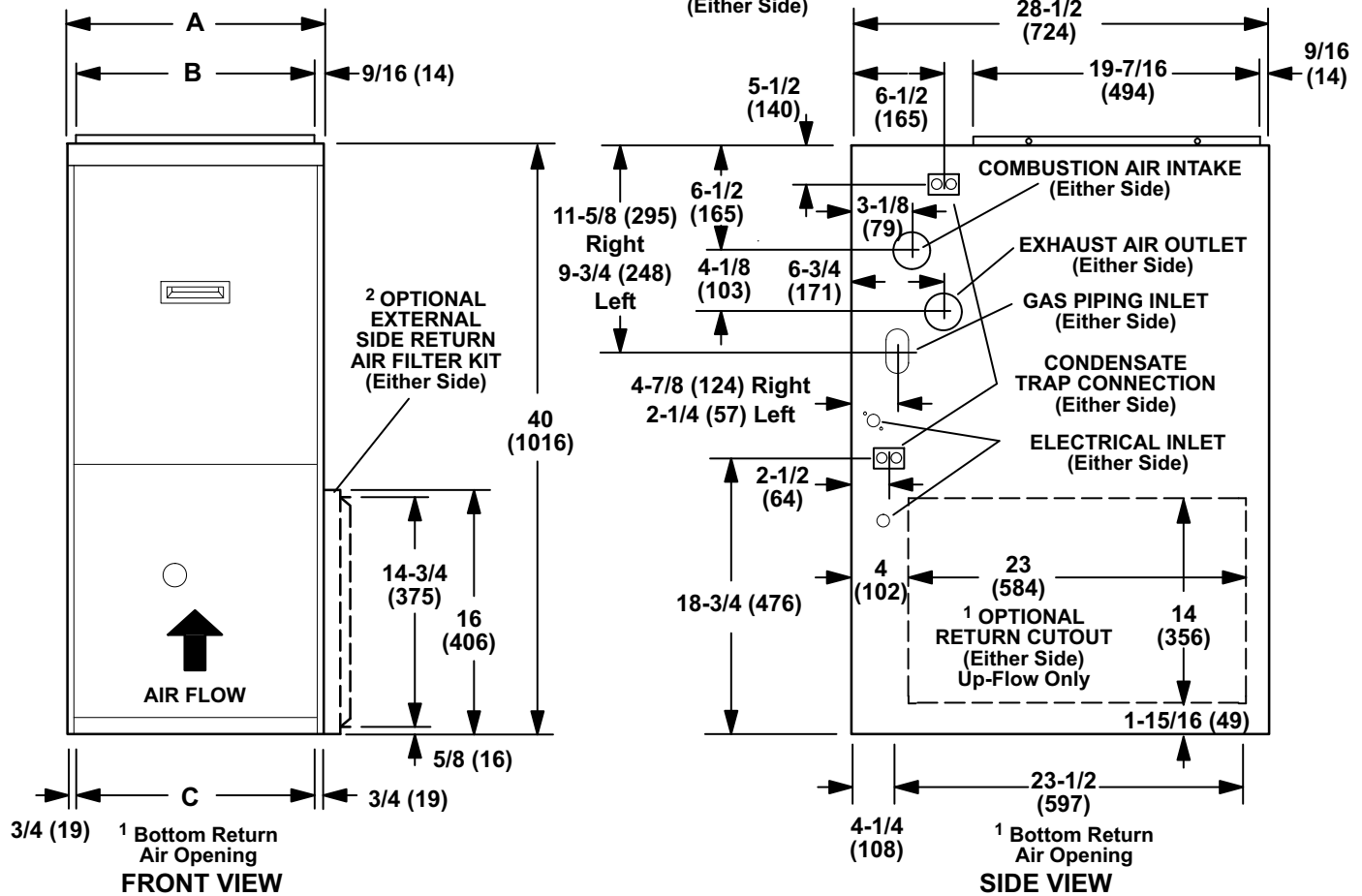
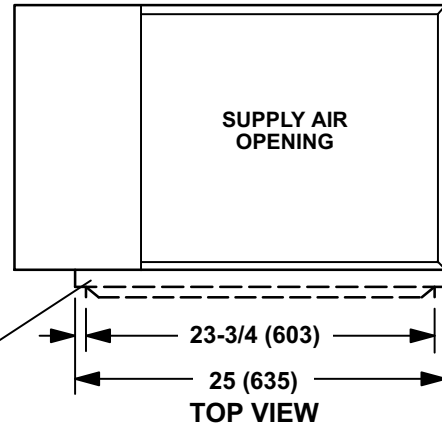

Model No.	A		B		C	
	in.	mm	in.	mm	in.	mm
G61MPV-36B-045 G61MPV-36B-070 G61MPV-36B-071	17-1/2	446	16-3/8	416	16	406
G61MPV-36C-090 G61MPV-60C-090 G61MPV-60C-091 G61MPV-60C-110 G61MPV-60C-111	21	533	19-7/8	504	19-1/2	495
G61MPV-60D-135	24-1/2	622	23-3/8	546	23	584

DIMENSIONS - INCHES (MM) - FURNACE/COIL COMBINED DIMENSIONS

UP-FLOW POSITION

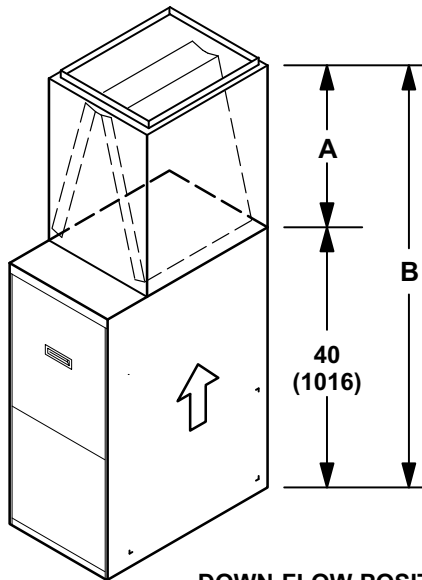

DOWN-FLOW POSITION

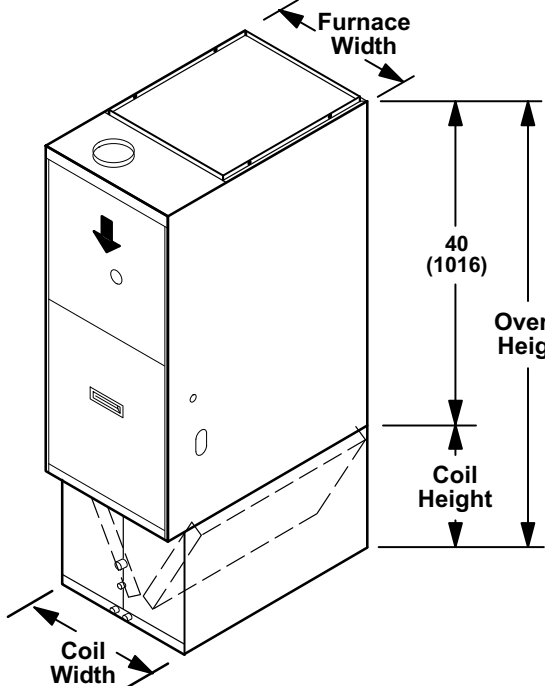

HORIZONTAL

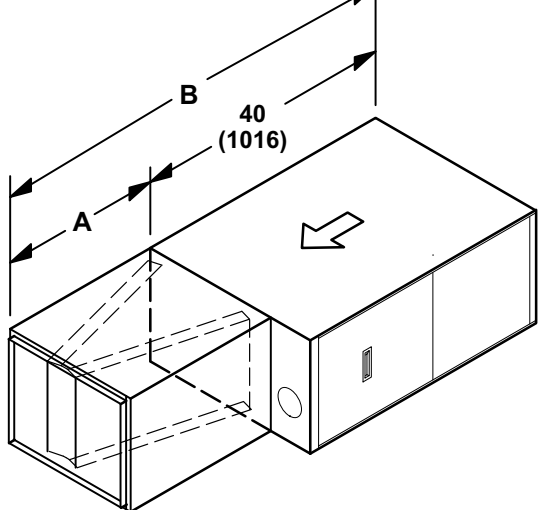

Model No	Cased				Uncased (CX34 - cased only)				
	A		B		A		B		
	in.	mm	in.	mm	in.	mm	in.	mm	
C33-18A	12-1/2	318	52-1/2	1334	9-3/4	248	49-3/4	1264	
CX34-19A-6F	C33-19A	16-1/2	419	56-1/2	1435	9-3/4	248	49-3/4	1264
C33-24A	16-1/2	419	56-1/2	1435	14	356	54	1372	
CX34-18/24A-6F	C33-24B	16-1/2	419	56-1/2	1435	13-7/8	352	53-7/8	1368
CX34-18/24B-6F	C33-24C								
CX34-18/24C-6F									
CX34-25A-6F	C33-25A	18-1/2	470	58-1/2	1486	16-1/4	413	56-1/4	1429
CX34-25B-6F	C33-25B	18-1/2	470	58-1/2	1486	15-7/8	403	55-7/8	1419
CX34-30B-6F	C33-30B	20-1/2	521	60-1/2	1537	17-3/4	451	59-3/4	1467
CX34-30C-6F	C33-30C								
CX34-30A-6F	C33-30A	20-1/2	521	60-1/2	1537	18	457	58	1473
CX34-31A-6F	C33-31A	22-1/2	572	62-1/2	1588	21-1/4	540	61-1/4	1556
CX34-31B-6F	C33-31B	22-1/2	572	62-1/2	1588	20-1/4	514	60-1/4	1530
CX34-36A-6F	C33-36A	24-1/2	622	64-1/2	1638	22-1/8	562	62-1/8	1578
CX34-36B-6F	C33-36B	24-1/2	622	64-1/2	1638	21-7/8	556	61-7/8	1572
CX34-36C-6F	C33-36C	24-1/2	622	64-1/2	1638	21-1/4	540	61-1/4	1556
CX34-38A-6F	C33-38A	24-1/2	622	64-1/2	1638	22-1/4	565	62-1/4	1581
CX34-38B-6F	C33-38B	24-1/2	622	64-1/2	1638	22	559	62	1575
CX34-42B-6F	C33-42B	24-1/2	622	64-1/2	1638	21-7/8	556	61-7/8	1572
CX34-43B-6F	C33-43B	27-1/2	699	67-1/2	1715	26-1/4	667	66-1/4	1683
CX34-43C-6F	C33-43C	27-1/2	699	67-1/2	1715	25-3/4	654	65-3/4	1670
C33-44C		24-1/2	622	64-1/2	1638	21-1/2	546	61-1/2	1562
CX34-44/48B-6F	C33-48B	24-1/2	622	64-1/2	1638	22-1/8	562	62-1/8	1578
CX34-44/48C-6F	C33-48C	24-1/2	622	64-1/2	1638	21-1/2	546	61-1/2	1562
CX34-49C-6F	C33-49C	30-1/2	775	70-1/2	1791	28-1/2	724	68-1/2	1740
CX34-50/60C-6F	C33-50/60C	27-1/2	699	67-1/2	1715	24-3/4	629	64-3/4	1645
CX34-60D-6F	C33-60D	25-1/2	648	65-1/2	1664	24-3/4	629	64-3/4	1645
CX34-62C-6F	C33-62C	31-1/2	800	71-1/2	1816	30-5/8	778	70-5/8	1793
CX34-62D-6F	C33-62D	29-1/2	749	69-1/2	1765	28-3/4	730	68-3/4	1746

DOWN-FLOW POSITION

Model Number	Coil Width		Furnace Width		Coil Height		Overall Height	
	in.	mm	in.	mm	in.	mm	in.	mm
CR33-24B-F	17-1/2	446	17-1/2	446	13-1/4	337	53-1/4	1353
CR33-30/36B-F	17-1/2	446	17-1/2	446	16-1/8	410	56-1/8	1426
CR33-30/36C-F	21	533	21	533	16-1/8	410	56-1/8	1426
CR33-48B-F	21	533	17-1/2	446	20	508	60	1524
CR33-48C-F	21	533	21	533	20	508	60	1524
CR33-50/60C-F	24-1/2	622	21	533	23-5/8	600	53-5/8	1362
CR33-60D-F	24-1/2	622	24-1/2	622	23-5/8	600	53-5/8	1362

HORIZONTAL POSITION

Model Number	A		B	
	in.	mm	in.	mm
CH33-18A-2F	21-1/2	546	61-1/2	1562
CH33-24/30A-2F	26-1/2	673	66-1/2	1689
CH33-36A-2F				
CH33-36B-2F				
CH33-36C-2F				
CH33-44/48B-2F	31-1/2	800	71-1/2	1816
CH33-50/60C-2F				
CH33-42B-2F				
CH33-48C-2F				
CH33-60D-2F				
CH33-62D-2F				

OPTIONAL ACCESSORY DIMENSIONS - INCHES (MM)

RAB RETURN AIR BASE (Up-Flow Applications Only)

For use with B, C, and D size furnaces only

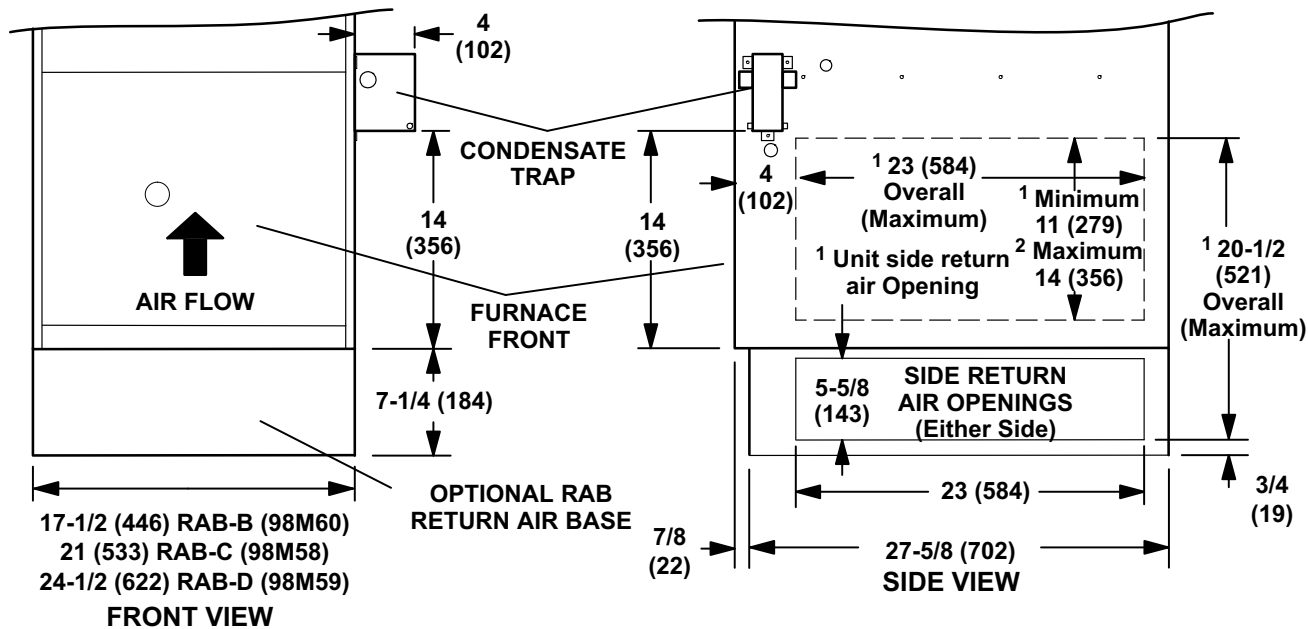

¹ Both the unit return air opening and the base return air opening must be covered by a single plenum or IAQ cabinet.

Minimum unit side return air opening dimensions for units requiring 1800 cfm or more of air (W x H): 23 x 11 in. (584 x 279 mm). The opening can be cut as needed to accommodate plenum or IAQ cabinet while maintaining dimensions shown.

Side return air openings must be cut in the field. There are cutting guides stenciled on the cabinet for the side return air opening. The size of the opening must not extend beyond the markings on the furnace cabinet.

² 14 inches (356 mm) is the maximum size the height of the unit opening can be cut. This may interfere with the condensate drain (if located on the same side of the unit as the opening).

To minimize pressure drop, the largest opening height possible (up to 14 inches) is preferred.

NOTE- Optional Side Return Air Filter Kits are not for use with RAB Return Air Base.

DOWN-FLOW ADDITIVE FLOOR BASE

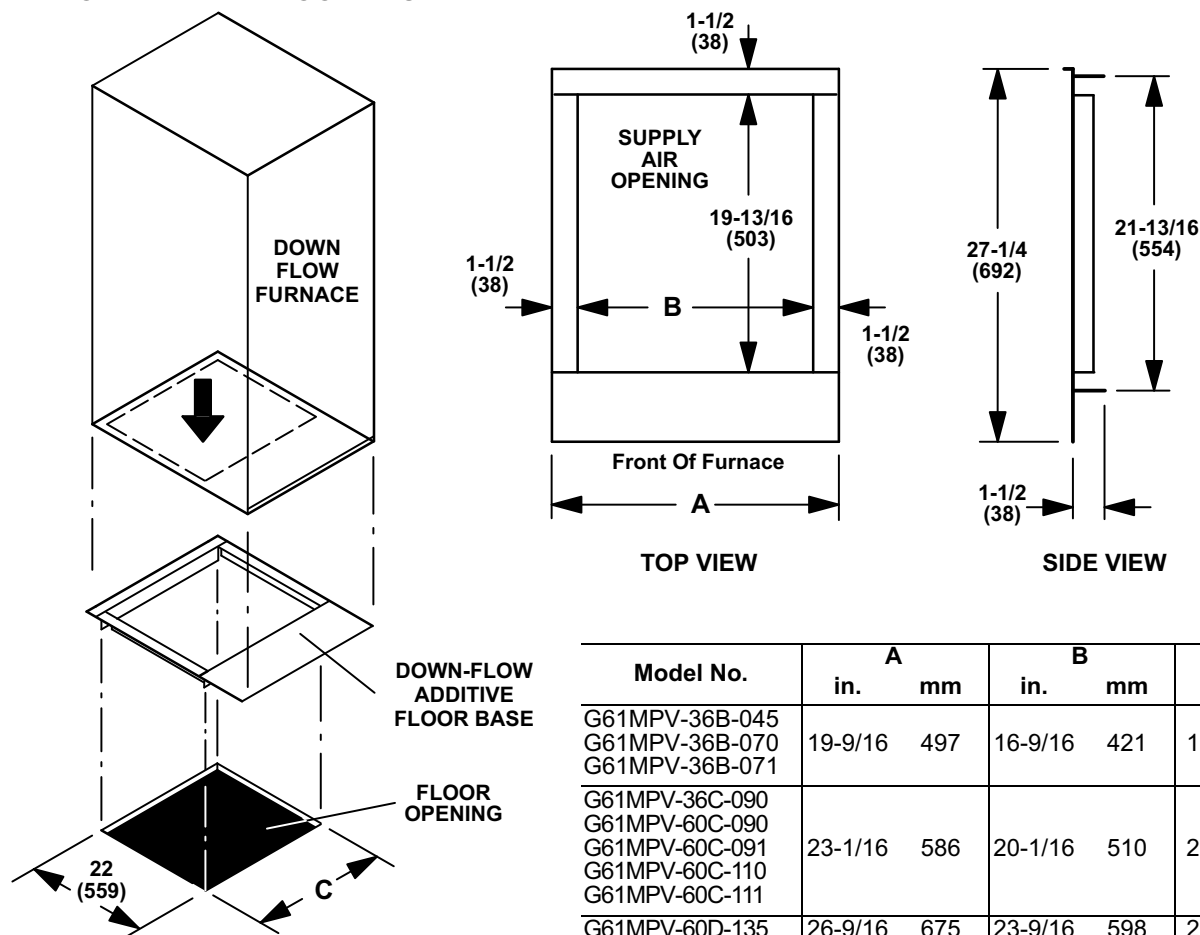

OPTIONAL ACCESSORY DIMENSIONS - INCHES (MM)

HORIZONTAL FILTER KIT

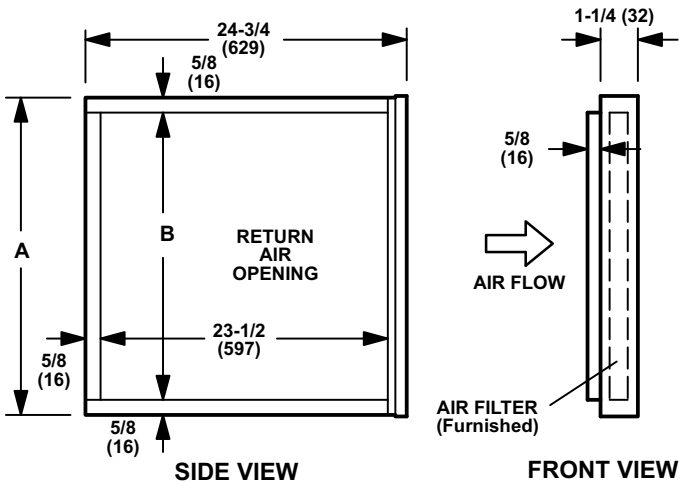

Catalog Number	A		B	
	inch	mm	inch	mm
87L96	18	457	16-3/4	425
87L97	21	533	18-3/4	476
87L98	25	635	23-3/4	603

CONCENTRIC WALL TERMINATION APPLICATIONS

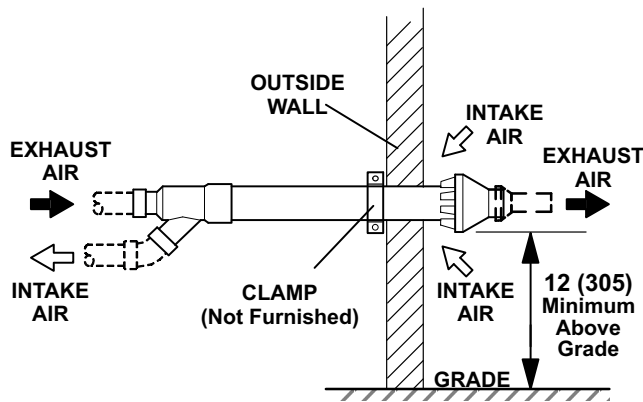

CONCENTRIC ROOF TERMINATION APPLICATIONS

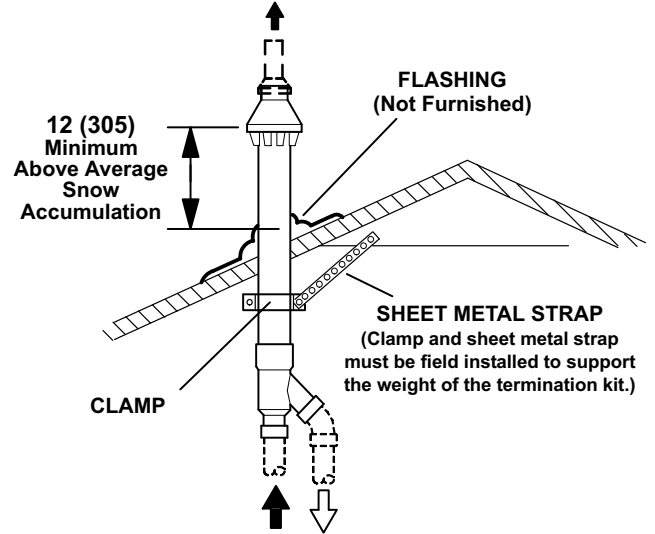

71M80 / 69M29 / 44W92 - 2 inch kits
 60L46 / 44W93 - 3 inch kits
 See Installation Instructions for specific usage.

Cat. No.	A		B	
	in.	mm	in.	mm
71M80 69M29	33-3/8	848	16-3/4	425
44W92 (Canada)	29	737	15-1/2	394
60L46	38-7/8	987	21-3/16	538
44W93 (Canada)	36-1/8	918	19-1/2	495

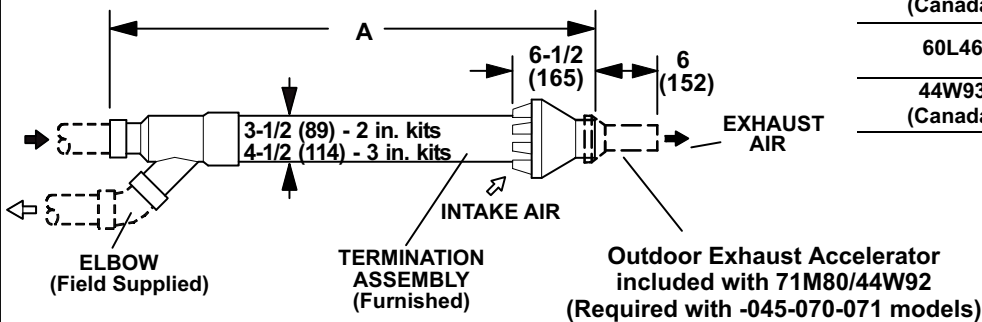

NOTE - Typical illustration for dimensions only. Design may vary depending on kit ordered.

OPTIONAL ACCESSORY DIMENSIONS - INCHES (MM)

WALL ASSEMBLY TERMINATION KIT - RING KIT

15F74 - 2 inch (51 mm)

See Installation Instructions for specific usage.

DIRECT VENT APPLICATION

NOTE - 12 in. (305 mm) minimum height above average snow accumulation.

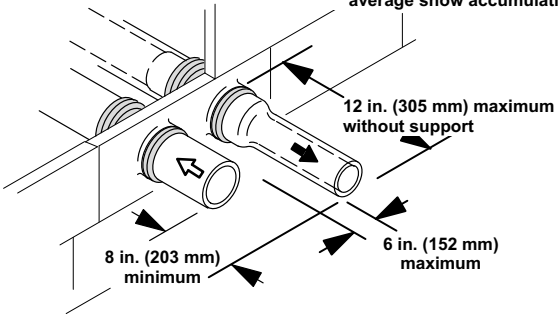

NON-DIRECT VENT APPLICATION
NOTE — EXHAUST PIPE SHOWN
Kit Contains Enough Parts For Two Installations

NOTE — 12 in. (305 mm) minimum height above average snow accumulation.

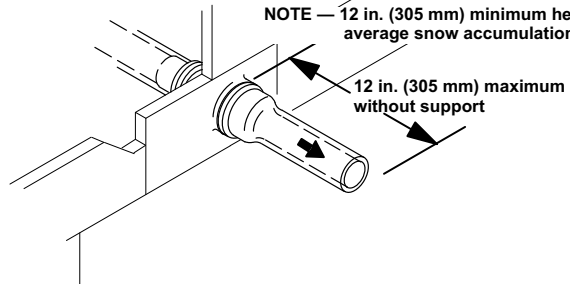

DIRECT VENT APPLICATIONS

WALL TERMINATION KITS (CLOSE-COUPLE)

22G44 - 2 inch (51 mm)

44J40 - 3 inch (76 mm)

See Installation Instructions for specific usage.

If Intake and Exhaust Pipe is less than 12 in. (305 mm) above snow accumulation or other obstructions, field fabricated piping must be installed.

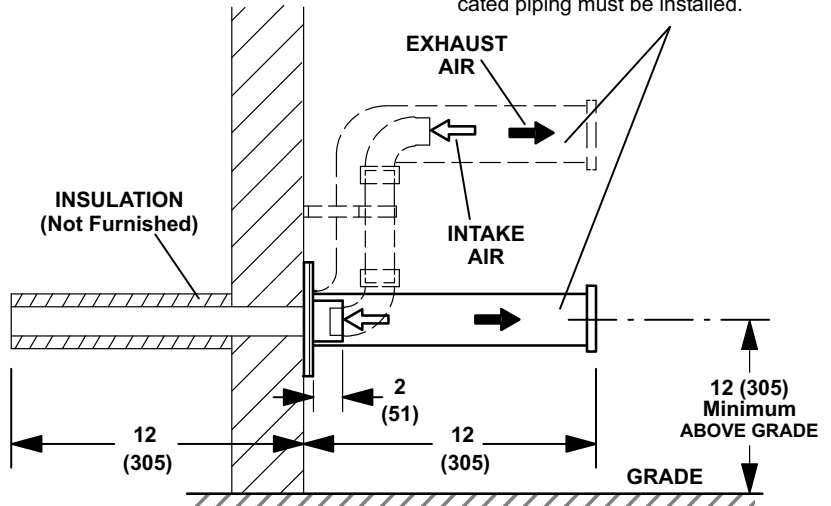
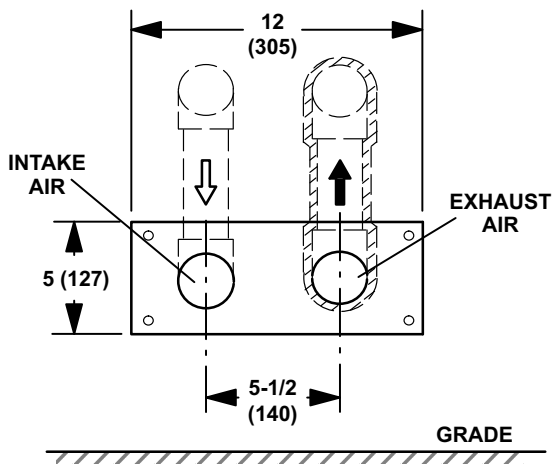

OPTIONAL ACCESSORY DIMENSIONS - INCHES (MM)

**DIRECT VENT APPLICATIONS
WTK WALL ASSEMBLY TERMINATION KIT (CANADA ONLY)
WITH FIELD FABRICATION ABOVE
GRADE EXTENDED CLEARANCE
30G28 - 2 inch (51 mm)
81J20 - 3 inch (76mm)**

See Installation Instructions for specific usage.

If Intake and Exhaust Pipe is less than 12 in. (305 mm) above snow accumulation or other obstructions, field fabricated piping must be installed.

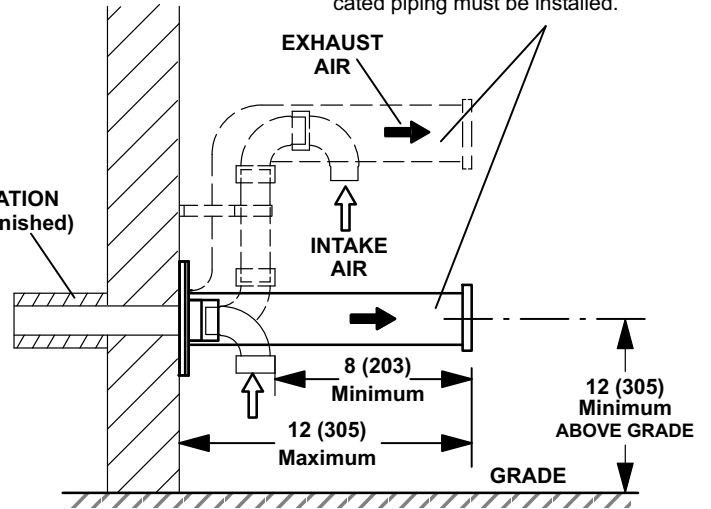
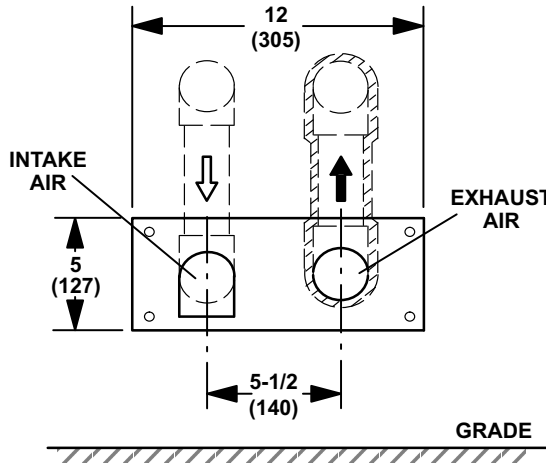

BLOWER DATA

G61MPV-36B-045 BLOWER PERFORMANCE (less filter)
0 through 0.80 in. w.g. External Static Pressure Range

"ADJUST" Switch Positions	Speed Switch Positions							
	Second Stage "HEAT" Speed - cfm				Second Stage "COOL" Speed - cfm			
	1	1 2	3	4	1	2	3	1 4
+	915	1070	1320	1370	1055	1235	1330	1420
1 NORM	830	965	1205	1255	945	1100	1185	1295
—	740	860	1055	1095	840	970	1050	1150

"ADJUST" Switch Positions	First Stage "HEAT" Speed - cfm				First Stage "COOL" Speed - cfm			
	1	1 2	3	4	1	2	3	1 4
	+	830	970	1210	1255	720	820	890
1 NORM	755	880	1080	1120	665	745	795	875
—	690	795	950	995	610	685	725	785

¹ Factory default jumper setting.

NOTES - The effect of static pressure is included in air volumes shown.

First stage HEAT is approximately 91% of the same second stage HEAT speed position.

First stage COOL (two-stage air conditioning units only) is approximately 70% of the same second stage COOL speed position.

Continuous Fan Only speed is approximately 38% of the same second stage COOL speed position - minimum 500 cfm.

Lennox Harmony III™ Zone Control Applications - Minimum blower speed is 442 cfm.

G61MPV-36B-045 BLOWER MOTOR WATTS

Jumper Speed Positions	Motor Watts @ Various External Static Pressures - in. wg.																		
	First Stage									Second Stage									
	0	0.1	0.2	0.3	0.4	0.5	0.6	0.7	0.8	0	0.1	0.2	0.3	0.4	0.5	0.6	0.7	0.8	
"+" (Plus) SETTING ("Adjust" Jumper at "+" Setting)																			
"HEAT" Speed	Tap 1	70	90	115	135	155	175	200	220	245	95	120	145	175	190	210	230	255	280
	Tap 2	125	145	165	185	205	225	255	280	305	155	175	200	225	255	290	310	335	360
	Tap 3	220	250	280	310	340	365	390	415	440	305	335	370	400	435	465	480	495	510
	Tap 4	225	260	300	345	375	410	430	450	470	330	360	395	430	460	485	510	530	550
"COOL" Speed	Tap 1	55	70	90	110	125	140	160	175	195	140	165	200	230	255	280	305	325	350
	Tap 2	70	90	110	130	155	175	200	220	240	230	260	295	330	360	390	415	435	460
	Tap 3	90	110	135	160	185	205	225	245	265	280	315	350	390	430	465	485	505	525
	Tap 4	115	135	160	185	210	235	255	280	300	370	410	450	490	520	555	560	565	570
"NORM" (Normal) SETTING ("Adjust" Jumper at "NORM" Setting)																			
"HEAT" Speed	Tap 1	65	80	95	110	135	155	170	190	210	80	95	115	135	155	175	200	220	240
	Tap 2	85	105	125	150	175	195	220	245	270	110	135	160	185	210	230	255	275	295
	Tap 3	150	175	205	230	265	295	320	345	365	205	230	260	295	330	370	390	415	440
	Tap 4	165	195	230	265	290	315	340	370	400	240	270	310	345	370	395	425	455	485
"COOL" Speed	Tap 1	45	60	75	95	115	130	145	160	175	110	130	155	185	205	230	250	275	295
	Tap 2	60	80	100	115	135	155	175	195	215	165	190	215	240	275	305	330	355	380
	Tap 3	70	85	110	130	150	165	190	210	230	195	225	260	290	320	350	375	400	425
	Tap 4	85	105	135	160	175	190	215	240	265	265	300	340	380	410	440	460	485	505
"-" (Minus) SETTING ("Adjust" Jumper at "-" Setting)																			
"HEAT" Speed	Tap 1	50	65	85	100	120	140	155	170	185	55	70	90	110	135	155	170	190	205
	Tap 2	70	90	105	125	145	165	185	205	230	85	100	125	145	175	200	220	235	250
	Tap 3	110	130	155	185	205	225	250	270	290	150	170	195	220	240	265	295	320	350
	Tap 4	125	145	170	200	220	240	265	295	320	160	185	215	245	265	290	315	335	360
"COOL" Speed	Tap 1	40	55	70	85	100	120	130	145	160	80	95	115	135	160	185	205	230	255
	Tap 2	55	65	80	95	115	135	150	165	185	115	140	170	195	215	235	260	280	300
	Tap 3	55	70	90	105	125	145	160	180	195	140	165	195	225	250	270	295	320	345
	Tap 4	75	90	105	125	140	155	180	200	225	180	205	235	265	295	325	355	380	410

BLOWER DATA

G61MPV-36B-070 BLOWER PERFORMANCE (less filter)
0 through 0.80 in. w.g. External Static Pressure Range

"ADJUST" Switch Positions	Speed Switch Positions							
	Second Stage "HEAT" Speed - cfm				Second Stage "COOL" Speed - cfm			
	1	1 2	3	4	1	2	3	1 4
+	895	1025	1290	1340	1015	1190	1280	1395
¹ NORM	820	940	1155	1210	930	1065	1155	1270
—	N/A	840	1020	1055	830	950	1010	1105

"ADJUST" Switch Positions	First Stage "HEAT" Speed - cfm				First Stage "COOL" Speed - cfm			
	1	1 2	3	4	1	2	3	1 4
	+	820	930	1160	1210	730	815	865
¹ NORM	760	865	1045	1090	680	755	795	855
—	N/A	775	930	965	625	695	730	775

¹ Factory default jumper setting.

N/A - First and second stage HEAT positions shown cannot be used on this model.

NOTES - The effect of static pressure is included in air volumes shown.

First stage HEAT is approximately **91%** of the same second stage HEAT speed position.

First stage COOL (two-stage air conditioning units only) is approximately **70%** of the same second stage COOL speed position.

Continuous Fan Only speed is approximately **38%** of the same second stage COOL speed position - minimum 500 cfm.

Lennox Harmony III™ Zone Control Applications - Minimum blower speed is 458 cfm.

G61MPV-36B-070 BLOWER MOTOR WATTS

Jumper Speed Positions	Motor Watts @ Various External Static Pressures - in. wg.																		
	First Stage									Second Stage									
	0	0.1	0.2	0.3	0.4	0.5	0.6	0.7	0.8	0	0.1	0.2	0.3	0.4	0.5	0.6	0.7	0.8	
"+" (Plus) SETTING ("Adjust" Jumper at "+" Setting)																			
"HEAT" Speed	Tap 1	70	85	105	130	150	170	190	205	225	110	115	135	155	175	195	215	240	260
	Tap 2	100	120	145	165	190	215	235	260	280	130	155	180	205	230	255	280	300	325
	Tap 3	185	210	240	270	290	310	345	375	405	250	280	310	340	370	400	425	450	475
	Tap 4	200	230	265	295	325	355	385	410	440	285	310	340	365	400	430	455	485	510
"COOL" Speed	Tap 1	55	70	90	110	130	145	160	175	190	135	155	175	200	220	245	270	295	320
	Tap 2	75	90	110	130	150	170	190	205	220	185	215	250	285	315	345	370	395	420
	Tap 3	85	100	120	145	165	185	205	225	250	235	265	300	335	370	400	425	455	480
	Tap 4	105	125	150	170	190	210	235	255	280	315	340	370	395	440	480	510	540	570
"NORM" (Normal) SETTING ("Adjust" Jumper at "NORM" Setting)																			
"HEAT" Speed	Tap 1	65	75	95	110	130	150	170	185	200	75	90	110	125	150	170	190	205	225
	Tap 2	85	100	120	140	160	180	200	225	245	100	120	145	165	190	210	230	250	270
	Tap 3	130	155	180	205	235	265	285	305	325	195	210	230	250	280	315	340	370	395
	Tap 4	145	170	200	230	255	280	305	330	355	200	225	255	280	315	355	375	400	425
"COOL" Speed	Tap 1	45	60	80	95	115	130	145	160	175	100	120	140	165	190	215	235	255	275
	Tap 2	60	75	95	110	130	145	165	180	200	140	165	190	220	245	265	290	315	340
	Tap 3	65	85	105	125	140	155	175	195	215	175	200	230	260	285	310	340	365	390
	Tap 4	85	100	120	140	160	180	200	220	240	230	260	295	325	360	390	410	435	455
"-" (Minus) SETTING ("Adjust" Jumper at "-" Setting)																			
"HEAT" Speed	Tap 1	N/A	N/A	N/A	N/A	N/A	N/A	N/A	N/A	N/A	N/A	N/A	N/A	N/A	N/A	N/A	N/A	N/A	N/A
	Tap 2	60	75	100	120	140	160	175	195	210	70	90	115	135	160	185	200	220	235
	Tap 3	95	120	145	170	190	210	230	245	265	140	160	180	205	225	245	270	295	325
	Tap 4	110	130	155	185	205	225	245	270	290	145	165	190	215	235	255	280	305	330
"COOL" Speed	Tap 1	40	55	70	85	100	120	130	145	160	75	90	110	125	150	175	190	210	225
	Tap 2	45	60	80	95	115	135	145	160	175	95	120	150	175	200	220	240	260	285
	Tap 3	50	65	85	105	125	145	160	175	190	125	150	175	195	220	240	265	290	320
	Tap 4	60	75	95	115	135	150	170	190	215	165	190	215	245	265	485	315	340	370

BLOWER DATA

G61MPV-36B-071 BLOWER PERFORMANCE (less filter)
0 through 0.80 in. w.g. External Static Pressure Range

"ADJUST" Switch Positions	Speed Switch Positions							
	Second Stage "HEAT" Speed - cfm				Second Stage "COOL" Speed - cfm			
	1	1 2	3	4	1	2	3	1 4
+	925	1065	1305	1345	1055	1225	1305	1405
1 NORM	840	970	1185	1230	955	1100	1185	1280
—	775	875	1050	1085	855	975	1040	1140

"ADJUST" Switch Positions	First Stage "HEAT" Speed - cfm				First Stage "COOL" Speed - cfm			
	1	1 2	3	4	1	2	3	1 4
	+	840	965	1190	1235	745	835	895
1 NORM	765	880	1070	1115	695	770	815	875
—	705	795	955	990	645	705	740	790

¹ Factory default jumper setting.

NOTES - The effect of static pressure is included in air volumes shown.

First stage HEAT is approximately 91% of the same second stage HEAT speed position.

First stage COOL (two-stage air conditioning units only) is approximately 70% of the same second stage COOL speed position.

Continuous Fan Only speed is approximately 38% of the same second stage COOL speed position - minimum 500 cfm.

Lennox Harmony III™ Zone Control Applications - Minimum blower speed is 458 cfm.

G61MPV-36B-071 BLOWER MOTOR WATTS

Jumper Speed Positions	Motor Watts @ Various External Static Pressures - in. wg.																		
	First Stage									Second Stage									
	0	0.1	0.2	0.3	0.4	0.5	0.6	0.7	0.8	0	0.1	0.2	0.3	0.4	0.5	0.6	0.7	0.8	
"+" (Plus) SETTING ("Adjust" Jumper at "+" Setting)																			
"HEAT" Speed	Tap 1	70	90	110	135	160	180	195	215	240	100	120	140	165	190	210	235	255	275
	Tap 2	115	135	160	185	205	230	250	270	295	160	185	210	230	255	275	295	315	330
	Tap 3	205	230	265	295	325	355	380	410	425	290	320	350	380	415	440	465	490	480
	Tap 4	220	250	290	325	360	390	425	455	455	310	345	375	410	445	475	500	525	515
"COOL" Speed	Tap 1	55	70	90	110	130	145	165	185	200	145	170	195	220	245	270	295	320	345
	Tap 2	70	90	115	135	160	180	200	220	240	225	255	285	315	350	375	400	425	445
	Tap 3	90	105	130	150	170	195	220	240	260	265	300	340	375	415	440	465	490	505
	Tap 4	110	130	155	180	205	230	250	270	295	360	390	425	460	495	515	540	560	535
"NORM" (Normal) SETTING ("Adjust" Jumper at "NORM" Setting)																			
"HEAT" Speed	Tap 1	60	75	95	115	135	155	175	195	215	75	95	115	140	160	180	200	220	240
	Tap 2	80	100	125	150	180	200	220	240	255	110	135	165	190	220	240	255	275	290
	Tap 3	150	170	200	225	250	275	300	325	350	210	235	260	285	315	345	375	405	425
	Tap 4	165	190	220	250	280	310	335	360	385	230	260	290	325	355	380	405	430	435
"COOL" Speed	Tap 1	45	60	80	95	115	130	150	165	185	110	130	155	180	205	225	245	265	285
	Tap 2	60	75	95	115	135	155	170	190	215	160	185	215	245	280	305	330	355	375
	Tap 3	70	85	105	130	150	170	190	215	235	205	230	260	290	320	350	380	410	420
	Tap 4	80	100	125	150	170	195	215	240	260	260	290	320	355	390	415	440	470	480
"-" (Minus) SETTING ("Adjust" Jumper at "-" Setting)																			
"HEAT" Speed	Tap 1	50	65	85	100	120	140	155	175	195	70	90	105	125	145	165	185	205	215
	Tap 2	65	80	100	120	140	165	185	205	225	90	110	130	155	175	195	215	235	250
	Tap 3	105	125	150	180	205	225	245	265	290	145	170	195	225	255	270	290	305	325
	Tap 4	115	135	165	190	215	240	260	285	310	160	185	215	240	270	290	310	330	350
"COOL" Speed	Tap 1	40	55	70	85	100	120	135	155	170	75	95	120	140	165	185	205	225	245
	Tap 2	45	60	80	100	115	135	150	170	185	115	135	160	190	215	235	255	270	295
	Tap 3	55	70	90	110	130	150	165	185	205	140	165	190	215	245	265	290	315	340
	Tap 4	60	75	100	120	140	165	185	205	225	180	205	235	265	295	320	345	365	390

BLOWER DATA

G61MPV-36C-090 BLOWER PERFORMANCE (less filter)
0 through 0.80 in. w.g. External Static Pressure Range

"ADJUST" Switch Positions	Speed Switch Positions							
	Second Stage "HEAT" Speed - cfm				Second Stage "COOL" Speed - cfm			
	1	1 2	3	4	1	2	3	1 4
+	N/A	1040	1285	1340	1020	1185	1275	1395
¹ NORM	N/A	915	1150	1200	905	1060	1145	1270
—	N/A	N/A	1020	1055	800	925	1010	1100

"ADJUST" Switch Positions	First Stage "HEAT" Speed - cfm				First Stage "COOL" Speed - cfm			
	1	1 2	3	4	1	2	3	1 4
	+	N/A	940	1160	1210	705	790	845
¹ NORM	N/A	840	1040	1075	650	730	770	830
—	N/A	N/A	915	945	600	670	705	750

¹ Factory default jumper setting.

N/A - First and second stage HEAT positions shown cannot be used on this model.

NOTES - The effect of static pressure is included in air volumes shown.

First stage HEAT is approximately **91%** of the same second stage HEAT speed position.

First stage COOL (two-stage air conditioning units only) is approximately **70%** of the same second stage COOL speed position.

Continuous Fan Only speed is approximately **38%** of the same second stage COOL speed position - minimum 500 cfm.

Lennox Harmony III™ Zone Control Applications - Minimum blower speed is 479 cfm.

G61MPV-36C-090 BLOWER MOTOR WATTS

Jumper Speed Positions	Motor Watts @ Various External Static Pressures - in. wg.																		
	First Stage									Second Stage									
	0	0.1	0.2	0.3	0.4	0.5	0.6	0.7	0.8	0	0.1	0.2	0.3	0.4	0.5	0.6	0.7	0.8	
"+" (Plus) SETTING ("Adjust" Jumper at "+" Setting)																			
"HEAT" Speed	Tap 1	N/A	N/A	N/A	N/A	N/A	N/A	N/A	N/A	N/A	N/A	N/A	N/A	N/A	N/A	N/A	N/A	N/A	
	Tap 2	75	90	110	130	155	185	205	225	250	90	110	140	165	185	205	235	260	290
	Tap 3	125	150	175	200	230	260	290	325	355	170	195	230	265	290	330	360	395	425
	Tap 4	130	160	200	235	265	295	325	355	385	185	220	255	290	325	360	395	430	460
"COOL" Speed	Tap 1	35	50	70	90	105	125	140	160	175	85	110	135	160	185	205	235	265	295
	Tap 2	45	60	80	100	125	150	170	185	205	125	155	185	220	245	275	305	330	360
	Tap 3	60	75	95	110	135	160	180	200	220	165	195	230	265	300	330	355	380	410
	Tap 4	65	85	110	135	160	180	205	225	245	210	245	285	325	360	390	425	460	495
"NORM" (Normal) SETTING ("Adjust" Jumper at "NORM" Setting)																			
"HEAT" Speed	Tap 1	N/A	N/A	N/A	N/A	N/A	N/A	N/A	N/A	N/A	N/A	N/A	N/A	N/A	N/A	N/A	N/A	N/A	
	Tap 2	50	65	90	110	135	155	175	200	220	60	80	105	130	155	185	205	220	240
	Tap 3	90	110	145	175	200	225	245	270	290	110	135	170	205	230	250	285	320	355
	Tap 4	90	120	155	190	205	225	250	280	305	140	165	190	220	255	290	315	335	360
"COOL" Speed	Tap 1	35	45	60	75	95	115	130	145	160	60	80	110	135	155	175	195	215	235
	Tap 2	40	55	70	90	110	130	150	165	185	105	125	145	170	200	225	250	270	295
	Tap 3	45	60	80	95	115	135	155	175	195	115	140	175	205	235	265	290	315	335
	Tap 4	50	65	85	105	130	155	180	200	220	155	185	220	255	285	315	345	380	415
"-" (Minus) SETTING ("Adjust" Jumper at "-" Setting)																			
"HEAT" Speed	Tap 1	N/A	N/A	N/A	N/A	N/A	N/A	N/A	N/A	N/A	N/A	N/A	N/A	N/A	N/A	N/A	N/A	N/A	
	Tap 2	N/A	N/A	N/A	N/A	N/A	N/A	N/A	N/A	N/A	N/A	N/A	N/A	N/A	N/A	N/A	N/A	N/A	
	Tap 3	65	85	105	130	155	180	200	225	250	85	105	135	160	185	205	230	250	270
	Tap 4	75	95	120	140	165	190	210	230	250	90	115	140	170	190	215	245	275	305
"COOL" Speed	Tap 1	30	40	55	75	90	105	120	135	150	55	65	85	105	125	150	170	190	210
	Tap 2	40	50	65	80	100	120	130	145	160	65	90	120	145	165	185	205	225	250
	Tap 3	40	55	70	90	105	125	140	160	180	85	105	135	165	185	210	235	260	285
	Tap 4	45	60	75	90	115	135	155	170	190	105	125	150	175	210	240	275	305	335

BLOWER DATA

G61MPV-60C-090 BLOWER PERFORMANCE (less filter)

Bottom Return Air, Return Air from Both Sides or Return Air from Bottom and One Side.

0 through 0.80 in. w.g. External Static Pressure Range

"ADJUST" Switch Positions	Speed Switch Positions							
	Second Stage "HEAT" Speed - cfm				Second Stage "COOL" Speed - cfm			
	1	1 2	3	4	1	2	3	1 4
+	1500	1675	1880	2090	1605	1710	1925	2165
¹ NORM	1355	1545	1720	1900	1440	1560	1755	1960
—	1194	1365	1540	1695	1275	1380	1590	1755

"ADJUST" Switch Positions	First Stage "HEAT" Speed - cfm				First Stage "COOL" Speed - cfm			
	1	1 2	3	4	1	2	3	1 4
	+	1360	1560	1730	1910	1105	1185	1355
¹ NORM	1220	1405	1585	1740	995	1080	1205	1345
—	1105	1235	1410	1570	890	960	1090	1215

¹ Factory default jumper setting.

NOTES - The effect of static pressure is included in air volumes shown.

First stage HEAT is approximately 91% of the same second stage HEAT speed position.

First stage COOL (two-stage air conditioning units only) is approximately 70% of the same second stage COOL speed position.

Continuous Fan Only speed is approximately 38% of the same second stage COOL speed position - minimum 500 cfm.

Lennox Harmony III™ Zone Control Applications - Minimum blower speed is 449 cfm.

G61MPV-60C-090 BLOWER MOTOR WATTS

Jumper Speed Positions	Motor Watts @ Various External Static Pressures - in. wg.																		
	First Stage									Second Stage									
	0	0.1	0.2	0.3	0.4	0.5	0.6	0.7	0.8	0	0.1	0.2	0.3	0.4	0.5	0.6	0.7	0.8	
"+" (Plus) SETTING ("Adjust" Jumper at "+" Setting)																			
"HEAT" Speed	Tap 1	190	215	245	275	305	340	365	390	420	245	275	315	350	380	410	440	475	510
	Tap 2	265	300	340	380	415	450	480	510	540	350	385	420	455	490	525	555	580	610
	Tap 3	380	415	450	485	520	555	595	630	665	485	520	555	595	640	685	720	755	790
	Tap 4	495	535	580	625	660	700	735	770	805	650	695	750	800	850	900	925	955	985
"COOL" Speed	Tap 1	115	135	160	185	205	230	255	275	300	305	340	375	410	440	475	505	535	565
	Tap 2	145	165	190	215	240	265	285	305	325	355	390	430	470	510	550	580	610	635
	Tap 3	170	200	240	275	305	335	370	400	430	510	555	600	645	690	730	765	795	830
	Tap 4	265	295	330	365	400	435	465	500	535	725	780	835	895	935	975	1005	1035	1065
"NORM" (Normal) SETTING ("Adjust" Jumper at "NORM" Setting)																			
"HEAT" Speed	Tap 1	150	170	195	220	245	270	295	325	350	180	210	245	280	305	330	365	400	430
	Tap 2	200	230	270	305	330	355	385	415	450	265	295	335	375	405	430	465	500	535
	Tap 3	270	310	355	395	425	460	490	525	560	370	400	435	470	515	555	585	615	645
	Tap 4	390	420	455	490	525	555	595	630	670	495	530	570	605	645	685	720	755	795
"COOL" Speed	Tap 1	90	110	130	155	175	195	215	235	255	220	250	285	320	350	385	415	450	485
	Tap 2	110	130	155	180	200	220	245	265	285	270	305	345	385	420	455	485	515	545
	Tap 3	145	165	190	215	245	270	295	320	340	390	425	465	500	540	580	610	640	670
	Tap 4	180	205	240	270	300	330	365	395	430	540	580	625	670	710	755	795	830	870
"-" (Minus) SETTING ("Adjust" Jumper at "-" Setting)																			
"HEAT" Speed	Tap 1	110	135	165	190	215	235	255	280	300	155	175	195	215	245	270	295	315	340
	Tap 2	155	175	200	225	255	285	310	335	365	190	215	250	285	310	335	365	395	425
	Tap 3	200	230	270	305	335	365	395	420	450	255	290	335	375	400	430	465	495	530
	Tap 4	270	305	345	385	415	450	480	515	545	345	385	425	465	495	530	565	605	645
"COOL" Speed	Tap 1	70	85	105	125	145	165	185	205	225	160	190	220	255	275	300	330	360	390
	Tap 2	80	100	120	140	165	190	210	225	245	195	225	260	295	325	350	385	415	450
	Tap 3	110	130	160	185	205	225	250	275	300	295	330	365	400	430	460	495	535	570
	Tap 4	155	175	195	220	245	270	295	315	340	400	435	470	510	545	585	610	640	665

BLOWER DATA

G61MPV-60C-090 BLOWER PERFORMANCE (less filter)

Side Return Air with Optional RAB Return Air Base

0 through 0.80 in. w.g. External Static Pressure Range

"ADJUST" Switch Positions	Speed Switch Positions							
	Second Stage "HEAT" Speed - cfm				Second Stage "COOL" Speed - cfm			
	1	1 2	3	4	1	2	3	1 4
+	1440	1630	1810	2015	1525	1655	1860	2100
¹ NORM	1300	1485	1655	1830	1385	1500	1695	1905
—	1155	1310	1480	1640	1240	1320	1510	1695

"ADJUST" Switch Positions	First Stage "HEAT" Speed - cfm				First Stage "COOL" Speed - cfm			
	1	1 2	3	4	1	2	3	1 4
	+	1320	1490	1665	1840	1060	1135	1285
¹ NORM	1180	1345	1515	1680	960	1035	1165	1310
—	1055	1180	1340	1490	865	920	1050	1165

¹ Factory default jumper setting.

NOTES - The effect of static pressure is included in air volumes shown.

First stage HEAT is approximately 91% of the same second stage HEAT speed position.

First stage COOL (two-stage air conditioning units only) is approximately 70% of the same second stage COOL speed position.

Continuous Fan Only speed is approximately 38% of the same second stage COOL speed position - minimum 500 cfm.

Lennox Harmony III™ Zone Control Applications - Minimum blower speed is 449 cfm.

G61MPV-60C-090 BLOWER MOTOR WATTS

Jumper Speed Positions	Motor Watts @ Various External Static Pressures - in. wg.																		
	First Stage									Second Stage									
	0	0.1	0.2	0.3	0.4	0.5	0.6	0.7	0.8	0	0.1	0.2	0.3	0.4	0.5	0.6	0.7	0.8	
"+" (Plus) SETTING ("Adjust" Jumper at "+" Setting)																			
"HEAT" Speed	Tap 1	180	205	235	260	290	320	350	380	410	230	260	290	320	355	390	420	445	475
	Tap 2	250	280	315	350	385	425	455	485	515	325	360	400	435	465	495	530	565	595
	Tap 3	345	380	415	455	485	515	550	580	615	460	490	520	550	595	640	675	715	750
	Tap 4	465	505	545	585	625	660	695	730	760	665	685	710	735	775	820	860	900	940
"COOL" Speed	Tap 1	110	130	150	175	195	215	240	265	290	275	305	340	380	410	440	470	505	540
	Tap 2	130	155	175	200	220	245	265	290	315	360	390	420	455	485	515	550	590	625
	Tap 3	160	190	220	255	280	305	335	360	390	490	530	570	610	645	680	715	750	785
	Tap 4	220	255	295	330	365	400	430	460	490	695	750	805	855	895	935	965	995	1025
"NORM" (Normal) SETTING ("Adjust" Jumper at "NORM" Setting)																			
"HEAT" Speed	Tap 1	145	165	190	210	235	260	285	310	335	170	195	230	260	290	320	350	375	400
	Tap 2	195	220	250	275	305	335	365	395	420	255	285	315	345	370	395	430	465	500
	Tap 3	280	305	335	360	395	425	455	485	515	340	375	410	450	480	510	545	580	615
	Tap 4	370	400	430	460	495	530	565	595	625	465	500	535	575	610	645	685	725	765
"COOL" Speed	Tap 1	80	95	120	140	165	190	210	235	255	190	225	265	305	330	355	390	420	455
	Tap 2	100	120	140	165	190	215	235	255	275	265	295	325	355	390	420	455	495	530
	Tap 3	140	160	185	205	235	260	285	305	325	375	410	440	475	500	530	570	610	650
	Tap 4	180	205	240	270	300	325	350	380	405	520	560	605	645	685	720	760	805	845
"-" (Minus) SETTING ("Adjust" Jumper at "-" Setting)																			
"HEAT" Speed	Tap 1	100	125	150	175	200	220	245	265	290	135	155	180	200	225	250	275	300	330
	Tap 2	150	165	185	205	235	265	290	310	335	170	200	235	265	290	320	350	375	405
	Tap 3	210	230	255	275	310	345	370	400	425	255	285	315	350	370	390	430	470	510
	Tap 4	260	290	320	350	390	430	455	480	505	340	375	410	445	475	510	535	565	590
"COOL" Speed	Tap 1	70	85	105	125	140	160	180	200	220	155	175	200	225	255	290	315	340	365
	Tap 2	80	95	115	135	155	175	200	220	245	185	210	235	260	295	325	355	385	415
	Tap 3	105	125	150	175	200	220	240	265	290	255	290	330	365	400	430	460	490	520
	Tap 4	135	160	185	215	235	260	285	305	330	370	400	440	475	505	530	565	600	635

BLOWER DATA

G61MPV-60C-090 BLOWER PERFORMANCE (less filter)

Single Side Return Air - Air volumes in bold require field fabricated transition to accommodate 20 x 25 x 1 in. cleanable air filter in order to maintain proper air velocity across the filter.

0 through 0.80 in. w.g. External Static Pressure Range

"ADJUST" Switch Positions	Speed Switch Positions							
	Second Stage "HEAT" Speed - cfm				Second Stage "COOL" Speed - cfm			
	1	1 2	3	4	1	2	3	1 4
+	1450	1640	1820	2055	1575	1690	1895	2135
¹ NORM	1320	1510	1700	1870	1405	1530	1735	1935
—	1165	1320	1500	1665	1250	1355	1560	1735

"ADJUST" Switch Positions	First Stage "HEAT" Speed - cfm				First Stage "COOL" Speed - cfm			
	1	1 2	3	4	1	2	3	1 4
	+	1315	1510	1695	1875	1080	1160	1315
¹ NORM	1190	1365	1545	1715	985	1060	1185	1330
—	1075	1205	1370	1520	865	930	1065	1185

¹ Factory default jumper setting.

NOTES - The effect of static pressure is included in air volumes shown.

First stage HEAT is approximately **91%** of the same second stage HEAT speed position.

First stage COOL (two-stage air conditioning units only) is approximately **70%** of the same second stage COOL speed position.

Continuous Fan Only speed is approximately **38%** of the same second stage COOL speed position - minimum 500 cfm.

Lennox Harmony III™ Zone Control Applications - Minimum blower speed is 449 cfm.

G61MPV-60C-090 BLOWER MOTOR WATTS

Jumper Speed Positions	Motor Watts @ Various External Static Pressures - in. wg.																		
	First Stage									Second Stage									
	0	0.1	0.2	0.3	0.4	0.5	0.6	0.7	0.8	0	0.1	0.2	0.3	0.4	0.5	0.6	0.7	0.8	
"+" (Plus) SETTING ("Adjust" Jumper at "+" Setting)																			
"HEAT" Speed	Tap 1	170	200	230	265	295	325	355	385	415	225	255	290	325	360	390	425	455	490
	Tap 2	255	285	320	355	390	425	455	490	520	330	370	410	455	485	515	540	560	585
	Tap 3	345	385	430	475	515	555	585	610	640	445	480	520	560	610	660	700	735	775
	Tap 4	470	515	560	610	650	685	725	765	800	650	695	745	800	840	885	915	950	980
"COOL" Speed	Tap 1	110	130	155	180	205	225	245	270	290	285	320	355	390	430	465	500	535	565
	Tap 2	125	150	175	205	225	250	275	300	325	355	390	430	470	500	530	570	605	645
	Tap 3	170	195	230	260	290	325	355	385	415	515	550	590	625	670	710	750	795	840
	Tap 4	240	275	315	355	380	405	445	485	525	740	785	835	885	920	955	990	1020	1050
"NORM" (Normal) SETTING ("Adjust" Jumper at "NORM" Setting)																			
"HEAT" Speed	Tap 1	145	165	190	215	240	265	290	315	345	175	200	235	265	300	330	360	385	415
	Tap 2	195	225	255	290	320	345	375	405	435	260	290	325	355	390	425	455	490	520
	Tap 3	265	300	335	370	405	435	470	505	540	360	395	435	470	515	555	585	620	650
	Tap 4	385	420	460	495	525	555	590	625	660	475	515	560	600	640	685	720	760	800
"COOL" Speed	Tap 1	85	100	125	145	170	200	215	235	255	200	230	270	310	340	370	400	430	460
	Tap 2	105	125	150	170	195	220	240	260	280	260	295	330	365	400	440	470	500	530
	Tap 3	135	160	185	215	240	270	290	315	335	410	440	470	500	540	580	610	640	670
	Tap 4	170	200	235	265	305	340	365	390	415	550	585	620	655	695	740	780	825	865
"-" (Minus) SETTING ("Adjust" Jumper at "-" Setting)																			
"HEAT" Speed	Tap 1	105	130	155	180	205	225	245	270	290	130	155	180	204	230	260	285	310	335
	Tap 2	145	165	195	220	250	280	305	335	360	170	195	230	265	295	325	355	385	420
	Tap 3	190	220	250	285	315	345	375	405	440	245	280	315	350	385	420	450	485	520
	Tap 4	270	295	325	355	395	430	465	500	530	340	375	415	455	490	525	560	595	625
"COOL" Speed	Tap 1	65	80	100	120	140	160	180	205	225	155	180	215	245	265	290	320	345	375
	Tap 2	75	90	110	130	155	180	200	220	245	190	220	250	275	305	335	370	400	430
	Tap 3	100	120	150	175	200	220	245	265	290	290	320	355	385	415	445	485	520	560
	Tap 4	135	160	185	215	240	265	290	315	335	405	435	465	495	540	585	610	640	665

BLOWER DATA

G61MPV-60C-091 BLOWER PERFORMANCE (less filter)

Bottom Return Air, Return Air from Both Sides or Return Air from Bottom and One Side.

0 through 1.00 in. w.g. External Static Pressure Range

"ADJUST" Switch Positions	Speed Switch Positions							
	Second Stage "HEAT" Speed - cfm				Second Stage "COOL" Speed - cfm			
	1	1 2	3	4	1	2	3	1 4
+	1560	1770	1895	2110	1665	1790	1990	2175
¹ NORM	1400	1575	1745	1930	1515	1625	1815	2020
—	1245	1400	1565	1745	1340	1445	1645	1800

"ADJUST" Switch Positions	First Stage "HEAT" Speed - cfm				First Stage "COOL" Speed - cfm			
	1	1 2	3	4	1	2	3	1 4
	+	1420	1625	1780	1965	1240	1245	1410
¹ NORM	1280	1465	1615	1790	1060	1125	1270	1430
—	1145	1290	1445	1610	940	1015	1145	1270

¹ Factory default jumper setting.

NOTES - The effect of static pressure is included in air volumes shown.

First stage HEAT is approximately **91%** of the same second stage HEAT speed position.

First stage COOL (two-stage air conditioning units only) is approximately 70% of the same second stage COOL speed position.

Continuous Fan Only speed is approximately **38%** of the same second stage COOL speed position - minimum 500 cfm.

Lennox Harmony III™ Zone Control Applications - Minimum blower speed is 458 cfm.

G61MPV-60C-091 BLOWER MOTOR WATTS

Jumper Speed Positions	Motor Watts @ Various External Static Pressures - in. wg.																		
	First Stage									Second Stage									
	0	0.1	0.2	0.3	0.4	0.5	0.6	0.7	0.8	0	0.1	0.2	0.3	0.4	0.5	0.6	0.7	0.8	
"+" (Plus) SETTING ("Adjust" Jumper at "+" Setting)																			
"HEAT" Speed	Tap 1	255	280	305	330	355	390	420	450	475	305	340	375	415	450	475	505	530	560
	Tap 2	325	360	390	425	460	500	540	580	615	395	440	490	540	585	620	655	690	730
	Tap 3	495	525	555	590	620	650	680	710	710	615	645	675	705	740	755	775	790	765
	Tap 4	625	660	700	740	780	815	855	890	890	800	840	880	920	960	985	1005	1030	1000
"COOL" Speed	Tap 1	180	200	225	250	280	300	320	345	370	390	420	455	485	520	550	585	615	640
	Tap 2	200	225	250	280	305	330	350	375	395	485	520	555	590	625	655	680	710	735
	Tap 3	245	270	300	335	365	390	420	445	470	655	700	740	785	830	860	890	925	930
	Tap 4	355	380	405	435	465	495	520	550	585	930	960	990	1020	1050	1060	1070	1045	1005
"NORM" (Normal) SETTING ("Adjust" Jumper at "NORM" Setting)																			
"HEAT" Speed	Tap 1	185	210	235	265	290	315	340	365	390	230	260	290	320	350	375	405	430	460
	Tap 2	240	270	305	340	375	410	445	475	505	300	335	370	410	450	485	520	560	595
	Tap 3	385	410	435	455	480	510	540	565	595	465	495	530	565	595	625	650	680	690
	Tap 4	480	510	540	570	600	605	670	705	740	585	626	670	710	750	785	820	855	870
"COOL" Speed	Tap 1	110	130	155	180	205	230	250	275	295	285	315	350	380	415	440	465	490	525
	Tap 2	140	160	185	205	230	250	265	285	310	345	380	420	460	495	525	550	580	615
	Tap 3	185	210	235	265	290	320	350	380	395	485	525	565	610	650	680	715	745	775
	Tap 4	245	275	305	335	365	395	420	450	480	680	720	765	810	855	885	910	940	960
"-" (Minus) SETTING ("Adjust" Jumper at "-" Setting)																			
"HEAT" Speed	Tap 1	145	165	190	210	235	255	280	300	320	175	195	225	250	275	295	320	340	365
	Tap 2	175	200	225	255	280	305	335	360	385	220	250	280	315	350	375	400	430	460
	Tap 3	275	305	330	360	385	410	435	460	485	365	390	410	435	460	485	510	535	555
	Tap 4	340	370	405	440	475	505	535	570	600	460	490	520	550	580	610	640	675	700
"COOL" Speed	Tap 1	90	105	125	145	165	185	205	225	245	215	240	270	300	325	350	375	395	425
	Tap 2	105	125	150	170	195	215	235	255	270	255	285	315	345	380	405	430	455	495
	Tap 3	145	165	190	215	235	260	280	305	325	385	410	440	470	495	535	570	605	630
	Tap 4	190	215	240	265	290	315	345	370	395	485	520	555	590	625	660	700	735	765

BLOWER DATA

G61MPV-60C-091 BLOWER PERFORMANCE (less filter)

Side Return Air with Optional RAB Return Air Base

0 through 1.00 in. w.g. External Static Pressure Range

"ADJUST" Switch Positions	Speed Switch Positions							
	Second Stage "HEAT" Speed - cfm				Second Stage "COOL" Speed - cfm			
	1	1 2	3	4	1	2	3	1 4
+	1490	1690	1850	2050	1590	1695	1905	2035
¹ NORM	1345	1520	1700	1870	1445	1535	1740	1900
—	1195	1345	1525	1675	1280	1370	1580	1700

"ADJUST" Switch Positions	First Stage "HEAT" Speed - cfm				First Stage "COOL" Speed - cfm			
	1	1 2	3	4	1	2	3	1 4
	+	1360	1550	1720	1880	1125	1195	1370
¹ NORM	1225	1400	1540	1715	1030	1085	1230	1380
—	1100	1225	1385	1540	915	980	1110	1225

¹ Factory default jumper setting.

NOTES - The effect of static pressure is included in air volumes shown.

First stage HEAT is approximately **91%** of the same second stage HEAT speed position.

First stage COOL (two-stage air conditioning units only) is approximately 70% of the same second stage COOL speed position.

Continuous Fan Only speed is approximately **38%** of the same second stage COOL speed position - minimum 500 cfm.

Lennox Harmony III™ Zone Control Applications - Minimum blower speed is 458 cfm.

G61MPV-60C-091 BLOWER MOTOR WATTS

Jumper Speed Positions	Motor Watts @ Various External Static Pressures - in. wg.																		
	First Stage									Second Stage									
	0	0.1	0.2	0.3	0.4	0.5	0.6	0.7	0.8	0	0.1	0.2	0.3	0.4	0.5	0.6	0.7	0.8	
"+" (Plus) SETTING ("Adjust" Jumper at "+" Setting)																			
"HEAT" Speed	Tap 1	210	235	265	295	325	350	380	405	435	265	295	330	365	400	425	450	480	500
	Tap 2	270	300	340	380	415	450	485	520	555	355	395	445	490	535	570	610	645	675
	Tap 3	430	455	490	520	550	580	610	645	675	530	656	600	640	675	700	730	755	775
	Tap 4	525	560	600	635	675	710	750	790	825	680	725	775	820	870	905	935	970	995
"COOL" Speed	Tap 1	145	165	185	210	230	255	275	295	315	353	380	410	440	470	500	530	555	580
	Tap 2	175	195	220	245	270	290	315	335	360	445	475	510	540	575	600	625	650	675
	Tap 3	230	260	285	315	345	370	395	420	450	640	680	725	765	810	840	870	905	890
	Tap 4	335	365	390	415	445	470	500	525	560	855	885	915	940	970	970	965	965	935
"NORM" (Normal) SETTING ("Adjust" Jumper at "NORM" Setting)																			
"HEAT" Speed	Tap 1	160	185	210	235	260	280	305	325	355	195	225	255	285	320	345	365	390	420
	Tap 2	205	235	265	295	330	355	385	415	450	250	285	325	365	405	435	465	495	530
	Tap 3	325	350	375	400	430	455	475	500	530	415	445	475	505	540	570	605	635	665
	Tap 4	410	445	475	510	545	575	605	640	670	505	545	585	625	660	700	740	780	815
"COOL" Speed	Tap 1	105	125	150	170	195	220	240	261	280	260	285	315	345	375	400	420	445	475
	Tap 2	135	155	180	200	225	240	260	275	300	320	350	385	420	455	480	505	530	565
	Tap 3	175	200	225	250	275	305	330	360	375	475	515	555	595	635	665	695	730	760
	Tap 4	235	260	290	320	350	375	405	430	460	625	665	705	750	790	815	840	865	855
"-" (Minus) SETTING ("Adjust" Jumper at "-" Setting)																			
"HEAT" Speed	Tap 1	120	140	165	190	215	235	260	285	305	150	170	195	220	245	270	295	320	345
	Tap 2	145	170	200	225	255	285	315	345	370	185	210	240	270	305	330	360	390	425
	Tap 3	230	255	285	315	345	370	395	420	445	310	335	365	390	415	445	470	495	520
	Tap 4	280	315	350	385	420	450	480	515	540	385	415	445	480	515	545	580	610	640
"COOL" Speed	Tap 1	85	100	120	140	160	180	195	215	235	195	220	245	270	295	315	335	360	385
	Tap 2	100	120	145	165	190	210	230	250	265	235	260	290	320	345	370	395	420	455
	Tap 3	140	155	180	200	225	245	265	285	305	375	400	430	455	485	520	555	590	620
	Tap 4	180	205	230	255	280	305	330	355	380	450	480	515	545	580	610	645	675	705

BLOWER DATA

G61MPV-60C-091 BLOWER PERFORMANCE (less filter)

Single Side Return Air - Air volumes in bold require field fabricated transition to accommodate 20 x 25 x 1 in. cleanable air filter in order to maintain proper air velocity across the filter.

0 through 1.00 in. w.g. External Static Pressure Range

"ADJUST" Switch Positions	Speed Switch Positions							
	Second Stage "HEAT" Speed - cfm				Second Stage "COOL" Speed - cfm			
	1	1 2	3	4	1	2	3	1 4
+	1510	1720	1810	2065	1615	1735	1900	2055
¹ NORM	1365	1535	1725	1880	1465	1575	1735	1915
—	1210	1360	1520	1700	1300	1400	1575	1715

"ADJUST" Switch Positions	First Stage "HEAT" Speed - cfm				First Stage "COOL" Speed - cfm			
	1	1 2	3	4	1	2	3	1 4
	+	1385	1560	1755	1900	1150	1220	1385
¹ NORM	1240	1400	1570	1750	1050	1105	1245	1395
—	1125	1260	1410	1560	930	995	1125	1240

¹ Factory default jumper setting.

NOTES - The effect of static pressure is included in air volumes shown.

First stage HEAT is approximately **91%** of the same second stage HEAT speed position.

First stage COOL (two-stage air conditioning units only) is approximately **70%** of the same second stage COOL speed position.

Continuous Fan Only speed is approximately **38%** of the same second stage COOL speed position - minimum 500 cfm.

Lennox Harmony III™ Zone Control Applications - Minimum blower speed is 458 cfm.

G61MPV-60C-091 BLOWER MOTOR WATTS

Jumper Speed Positions	Motor Watts @ Various External Static Pressures - in. wg.																		
	First Stage									Second Stage									
	0	0.1	0.2	0.3	0.4	0.5	0.6	0.7	0.8	0	0.1	0.2	0.3	0.4	0.5	0.6	0.7	0.8	
"+" (Plus) SETTING ("Adjust" Jumper at "+" Setting)																			
"HEAT" Speed	Tap 1	230	255	285	315	350	375	400	425	455	285	315	350	385	420	450	485	515	545
	Tap 2	290	325	365	405	445	480	510	545	585	370	410	455	500	545	585	625	670	705
	Tap 3	475	505	545	580	620	645	670	695	695	560	595	625	660	695	720	745	770	755
	Tap 4	570	610	655	700	740	775	805	835	835	750	790	835	880	925	960	995	1025	1010
"COOL" Speed	Tap 1	155	175	200	225	250	275	295	320	345	385	415	450	485	515	545	580	610	635
	Tap 2	175	200	225	250	275	300	320	340	370	470	500	535	570	600	630	655	685	710
	Tap 3	240	265	295	325	355	385	410	435	465	645	685	730	770	815	845	875	905	890
	Tap 4	355	380	410	440	465	495	525	555	590	905	935	965	995	1025	1025	1020	1020	985
"NORM" (Normal) SETTING ("Adjust" Jumper at "NORM" Setting)																			
"HEAT" Speed	Tap 1	160	190	220	250	280	305	325	350	375	215	240	270	300	330	360	390	415	445
	Tap 2	205	235	275	315	350	380	415	445	475	270	305	345	385	420	455	495	530	565
	Tap 3	360	385	415	440	465	490	515	540	570	450	480	515	545	580	605	630	660	690
	Tap 4	455	485	520	550	585	615	650	680	715	555	590	630	675	715	745	780	810	850
"COOL" Speed	Tap 1	115	135	160	185	210	235	260	280	300	285	315	345	380	410	435	460	485	520
	Tap 2	135	160	180	205	230	245	265	280	305	335	365	405	440	480	505	530	560	595
	Tap 3	180	205	230	260	285	315	345	370	390	475	515	555	595	640	670	700	730	760
	Tap 4	245	275	305	335	370	395	425	450	485	660	705	750	790	835	865	890	915	905
"-" (Minus) SETTING ("Adjust" Jumper at "-" Setting)																			
"HEAT" Speed	Tap 1	135	155	175	200	225	250	275	300	320	160	185	205	230	255	280	310	335	360
	Tap 2	160	185	215	240	270	300	335	365	390	200	225	255	285	310	345	380	415	445
	Tap 3	270	295	320	345	375	400	420	445	475	330	355	385	410	435	460	485	510	535
	Tap 4	325	355	385	420	450	480	510	535	575	420	450	485	515	550	580	610	640	670
"COOL" Speed	Tap 1	90	110	130	150	170	195	215	235	250	215	240	270	295	325	345	370	390	420
	Tap 2	105	125	145	170	195	215	235	255	270	245	275	305	335	365	390	415	440	475
	Tap 3	145	165	185	210	235	255	275	300	320	375	400	430	460	490	525	560	595	620
	Tap 4	190	215	240	265	290	320	345	375	400	475	510	545	575	610	645	680	715	745

BLOWER DATA

G61MPV-60C-110 BLOWER PERFORMANCE (less filter)

Bottom Return Air, Return Air from Both Sides or Return Air from Bottom and One Side.

0 through 0.80 in. w.g. External Static Pressure Range

"ADJUST" Switch Positions	Speed Switch Positions							
	Second Stage "HEAT" Speed - cfm				Second Stage "COOL" Speed - cfm			
	1	1 2	3	4	1	2	3	1 4
+	1505	1710	1915	2130	1625	1745	1990	2210
¹ NORM	1370	1565	1765	1945	1465	1580	1790	1995
—	1205	1380	1565	1740	1290	1405	1605	1790

"ADJUST" Switch Positions	First Stage "HEAT" Speed - cfm				First Stage "COOL" Speed - cfm			
	1	1 2	3	4	1	2	3	1 4
	+	1370	1570	1760	1945	1150	1215	1380
¹ NORM	1235	1420	1600	1780	1050	1125	1265	1430
—	1105	1250	1420	1580	935	1000	1140	1255

¹ Factory default jumper setting.

NOTES - The effect of static pressure is included in air volumes shown.

First stage HEAT is approximately 91% of the same second stage HEAT speed position.

First stage COOL (two-stage air conditioning units only) is approximately 70% of the same second stage COOL speed position.

Continuous Fan Only speed is approximately 38% of the same second stage COOL speed position - minimum 500 cfm.

Lennox Harmony III™ Zone Control Applications - Minimum blower speed is 463 cfm.

G61MPV-60C-110 BLOWER MOTOR WATTS

Jumper Speed Positions	Motor Watts @ Various External Static Pressures - in. wg.																		
	First Stage									Second Stage									
	0	0.1	0.2	0.3	0.4	0.5	0.6	0.7	0.8	0	0.1	0.2	0.3	0.4	0.5	0.6	0.7	0.8	
"+" (Plus) SETTING ("Adjust" Jumper at "+" Setting)																			
"HEAT" Speed	Tap 1	165	195	230	265	300	336	370	400	430	210	245	290	330	365	395	435	470	510
	Tap 2	245	285	325	370	400	435	470	505	540	330	365	405	445	480	520	560	600	640
	Tap 3	365	395	430	465	510	550	590	630	670	450	490	535	580	625	665	700	735	770
	Tap 4	480	520	565	610	645	685	725	770	810	625	670	715	760	805	850	890	930	970
"COOL" Speed	Tap 1	110	130	160	185	210	230	255	280	305	280	315	350	390	430	475	510	550	585
	Tap 2	135	155	180	210	230	255	285	315	350	340	380	425	465	505	545	575	610	645
	Tap 3	180	210	250	285	310	340	370	400	425	510	545	585	620	675	735	770	805	840
	Tap 4	235	270	310	350	380	420	450	480	515	710	755	805	855	905	950	980	1010	1035
"NORM" (Normal) SETTING ("Adjust" Jumper at "NORM" Setting)																			
"HEAT" Speed	Tap 1	150	170	190	205	245	280	305	335	365	170	200	235	270	300	330	365	400	430
	Tap 2	195	220	255	285	320	360	390	420	445	240	275	320	365	400	430	465	500	530
	Tap 3	265	300	335	370	410	445	480	520	555	360	395	435	475	510	550	585	620	650
	Tap 4	370	410	455	495	525	550	590	630	670	460	500	545	590	635	675	720	760	805
"COOL" Speed	Tap 1	100	115	135	150	180	210	235	255	275	205	235	275	310	345	380	415	450	485
	Tap 2	110	130	150	175	200	235	260	280	300	250	285	325	360	400	440	470	505	540
	Tap 3	155	180	200	225	250	280	310	340	370	375	410	445	485	530	575	605	635	670
	Tap 4	190	220	255	290	320	350	380	410	440	510	550	595	640	685	725	770	815	860
"-" (Minus) SETTING ("Adjust" Jumper at "-" Setting)																			
"HEAT" Speed	Tap 1	105	130	155	180	210	235	260	285	305	140	160	180	200	235	265	295	320	350
	Tap 2	140	165	195	225	250	280	310	345	375	165	195	230	265	300	335	370	405	440
	Tap 3	185	220	255	290	325	355	390	420	450	250	285	325	360	395	430	465	500	530
	Tap 4	250	290	335	375	410	445	480	520	560	340	375	420	460	495	530	565	605	645
"COOL" Speed	Tap 1	70	90	110	130	150	175	200	220	240	155	180	210	240	270	295	325	355	385
	Tap 2	80	100	120	145	170	200	220	240	260	185	215	245	280	315	345	380	415	450
	Tap 3	110	130	155	180	205	235	260	280	310	265	300	345	385	425	465	500	535	570
	Tap 4	160	180	200	225	250	275	300	330	360	375	415	455	495	535	575	615	650	690

BLOWER DATA

G61MPV-60C-110 BLOWER PERFORMANCE (less filter)

Single Side Return Air - Air volumes in bold require field fabricated transition to accommodate 20 x 25 x 1 in. cleanable air filter in order to maintain proper air velocity across the filter.

0 through 0.80 in. w.g. External Static Pressure Range

"ADJUST" Switch Positions	Speed Switch Positions							
	Second Stage "HEAT" Speed - cfm				Second Stage "COOL" Speed - cfm			
	1	1 2	3	4	1	2	3	1 4
+	1485	1675	1870	2080	1585	1700	1905	2135
¹ NORM	1350	1525	1725	1895	1435	1535	1740	1930
—	1175	1335	1505	1670	1280	1385	1570	1755

"ADJUST" Switch Positions	First Stage "HEAT" Speed - cfm				First Stage "COOL" Speed - cfm			
	1	1 2	3	4	1	2	3	1 4
	+	1325	1505	1695	1870	1140	1215	1345
¹ NORM	1195	1365	1550	1720	1005	1085	1220	1380
—	1080	1205	1365	1530	930	1000	1105	1220

¹ Factory default jumper setting.

NOTES - The effect of static pressure is included in air volumes shown.

First stage HEAT is approximately **91%** of the same second stage HEAT speed position.

First stage COOL (two-stage air conditioning units only) is approximately **70%** of the same second stage COOL speed position.

Continuous Fan Only speed is approximately **38%** of the same second stage COOL speed position - minimum 500 cfm.

Lennox Harmony III™ Zone Control Applications - Minimum blower speed is 463 cfm.

G61MPV-60C-110 BLOWER MOTOR WATTS

Jumper Speed Positions	Motor Watts @ Various External Static Pressures - in. wg.																		
	First Stage									Second Stage									
	0	0.1	0.2	0.3	0.4	0.5	0.6	0.7	0.8	0	0.1	0.2	0.3	0.4	0.5	0.6	0.7	0.8	
"+" (Plus) SETTING ("Adjust" Jumper at "+" Setting)																			
"HEAT" Speed	Tap 1	155	185	220	255	285	320	350	380	410	205	240	280	320	355	390	420	450	480
	Tap 2	215	255	300	345	370	395	430	465	500	320	350	380	410	455	495	530	565	595
	Tap 3	335	375	415	455	490	530	570	605	645	445	475	510	545	590	630	670	710	750
	Tap 4	450	490	535	580	615	645	690	730	775	580	625	680	735	770	810	850	890	930
"COOL" Speed	Tap 1	105	130	160	190	210	230	260	280	310	255	295	345	390	430	470	510	545	580
	Tap 2	125	150	175	200	225	250	280	310	335	340	375	415	455	490	525	570	615	660
	Tap 3	170	195	230	265	295	325	355	380	410	455	500	555	610	650	695	750	800	850
	Tap 4	215	250	295	340	375	405	440	470	500	650	710	770	835	880	920	960	995	1035
"NORM" (Normal) SETTING ("Adjust" Jumper at "NORM" Setting)																			
"HEAT" Speed	Tap 1	140	160	185	210	235	265	285	310	330	155	185	220	250	285	320	350	380	410
	Tap 2	170	200	235	270	305	340	370	400	430	220	260	300	345	370	395	430	465	500
	Tap 3	250	290	330	370	400	430	465	505	540	355	385	415	450	485	520	555	595	630
	Tap 4	360	395	430	465	510	550	580	605	635	460	490	525	560	605	645	685	730	770
"COOL" Speed	Tap 1	80	100	120	145	170	195	220	245	275	195	230	270	305	345	380	415	455	490
	Tap 2	95	115	140	165	190	220	240	270	295	225	265	315	360	400	440	475	515	555
	Tap 3	140	160	190	215	240	265	295	320	350	365	400	445	485	525	565	610	650	690
	Tap 4	175	205	240	270	305	340	370	400	430	495	535	580	625	675	725	770	815	860
"-" (Minus) SETTING ("Adjust" Jumper at "-" Setting)																			
"HEAT" Speed	Tap 1	105	125	150	175	195	215	240	265	290	135	155	180	205	225	245	275	300	330
	Tap 2	145	165	190	210	240	265	290	315	340	170	195	225	255	290	325	355	385	410
	Tap 3	175	200	235	265	300	335	370	400	430	230	260	295	335	370	405	440	475	510
	Tap 4	240	275	320	360	390	420	450	485	515	325	365	410	455	490	520	550	575	600
"COOL" Speed	Tap 1	60	80	100	125	150	170	195	220	245	155	180	205	235	270	305	340	370	400
	Tap 2	75	95	115	140	160	185	210	235	260	170	200	240	275	315	355	390	420	450
	Tap 3	105	125	150	175	200	225	250	275	295	250	290	330	375	410	445	485	525	570
	Tap 4	140	160	190	215	240	265	300	330	360	365	405	450	490	535	575	615	655	690

BLOWER DATA

G61MPV-60C-110 BLOWER PERFORMANCE (less filter)

Side Return Air with Optional RAB Return Air Base

0 through 0.80 in. w.g. External Static Pressure Range

"ADJUST" Switch Positions	Speed Switch Positions							
	Second Stage "HEAT" Speed - cfm				Second Stage "COOL" Speed - cfm			
	1	1 2	3	4	1	2	3	1 4
+	1475	1670	1865	2070	1555	1685	1895	2130
¹ NORM	1345	1500	1695	1865	1415	1540	1735	1930
—	1180	1345	1510	1685	1245	1350	1545	1725

"ADJUST" Switch Positions	First Stage "HEAT" Speed - cfm				First Stage "COOL" Speed - cfm			
	1	1 2	3	4	1	2	3	1 4
	+	1330	1510	1695	1875	1085	1155	1310
¹ NORM	1195	1375	1550	1725	955	1050	1185	1335
—	1080	1210	1370	1520	850	920	1070	1195

¹ Factory default jumper setting.

NOTES - The effect of static pressure is included in air volumes shown.

First stage HEAT is approximately 91% of the same second stage HEAT speed position.

First stage COOL (two-stage air conditioning units only) is approximately 70% of the same second stage COOL speed position.

Continuous Fan Only speed is approximately 38% of the same second stage COOL speed position - minimum 500 cfm.

Lennox Harmony III™ Zone Control Applications - Minimum blower speed is 463 cfm.

G61MPV-60C-110 BLOWER MOTOR WATTS

Jumper Speed Positions	Motor Watts @ Various External Static Pressures - in. wg.																		
	First Stage									Second Stage									
	0	0.1	0.2	0.3	0.4	0.5	0.6	0.7	0.8	0	0.1	0.2	0.3	0.4	0.5	0.6	0.7	0.8	
"+" (Plus) SETTING ("Adjust" Jumper at "+" Setting)																			
"HEAT" Speed	Tap 1	170	195	225	255	290	320	350	380	410	215	250	285	320	355	390	425	455	490
	Tap 2	230	265	305	345	380	415	445	480	515	315	355	400	445	480	510	540	575	605
	Tap 3	350	385	420	460	495	525	560	595	630	460	490	525	555	605	655	690	730	770
	Tap 4	450	490	535	580	610	640	680	720	760	590	630	680	725	785	840	880	915	955
"COOL" Speed	Tap 1	105	125	150	175	200	220	245	265	290	250	285	320	360	395	435	470	500	535
	Tap 2	130	150	175	200	220	240	270	295	320	335	365	405	445	480	515	550	590	630
	Tap 3	165	190	220	250	275	305	335	370	400	470	505	545	585	630	670	710	755	800
	Tap 4	205	240	285	330	360	390	420	450	485	655	695	745	790	840	885	925	965	1005
"NORM" (Normal) SETTING ("Adjust" Jumper at "NORM" Setting)																			
"HEAT" Speed	Tap 1	150	170	190	215	240	265	290	315	340	155	190	225	265	295	325	355	385	420
	Tap 2	185	215	245	275	310	340	370	400	430	230	265	300	335	370	400	440	475	515
	Tap 3	255	285	325	365	400	440	465	495	525	335	370	410	450	490	530	560	595	625
	Tap 4	345	385	430	475	510	545	575	605	635	460	490	520	550	595	645	680	715	750
"COOL" Speed	Tap 1	75	90	115	135	160	185	205	225	250	190	220	255	290	325	360	395	430	460
	Tap 2	100	120	145	165	185	205	230	255	280	250	285	325	360	390	420	455	485	520
	Tap 3	135	155	175	200	230	260	280	305	330	355	395	435	475	510	545	580	620	660
	Tap 4	170	195	225	255	290	320	350	375	405	475	515	565	610	655	705	745	785	825
"-" (Minus) SETTING ("Adjust" Jumper at "-" Setting)																			
"HEAT" Speed	Tap 1	110	130	150	175	195	215	240	265	290	135	155	180	210	230	250	275	300	325
	Tap 2	145	165	190	210	240	270	295	315	340	170	195	230	265	295	325	355	390	420
	Tap 3	175	205	240	280	310	340	370	400	430	220	255	295	335	370	405	440	475	515
	Tap 4	245	280	320	355	390	420	455	490	525	325	360	400	440	475	510	540	565	590
"COOL" Speed	Tap 1	55	70	90	110	135	155	175	195	220	150	170	200	225	255	285	315	340	370
	Tap 2	65	80	105	130	150	170	195	215	240	165	195	230	265	300	330	360	390	420
	Tap 3	100	125	150	180	200	220	240	260	280	240	280	320	360	400	435	470	505	540
	Tap 4	140	160	180	200	230	260	285	305	330	350	385	420	455	500	540	575	610	645

BLOWER DATA

G61MPV-60C-111 BLOWER PERFORMANCE (less filter)

Bottom Return Air, Return Air from Both Sides or Return Air from Bottom and One Side.

0 through 1.00 in. w.g. External Static Pressure Range

"ADJUST" Switch Positions	Speed Switch Positions							
	Second Stage "HEAT" Speed - cfm				Second Stage "COOL" Speed - cfm			
	1	1 2	3	4	1	2	3	1 4
+	1585	1810	1950	2170	1635	1750	1965	2195
¹ NORM	1430	1635	1770	1970	1480	1605	1805	2015
—	1265	1440	1600	1780	1290	1400	1605	1800

"ADJUST" Switch Positions	First Stage "HEAT" Speed - cfm				First Stage "COOL" Speed - cfm			
	1	1 2	3	4	1	2	3	1 4
	+	1450	1650	1790	1990	1120	1195	1380
¹ NORM	1295	1475	1630	1810	1020	1095	1225	1385
—	1165	1330	1470	1635	900	970	1105	1245

¹ Factory default jumper setting.

NOTES - The effect of static pressure is included in air volumes shown.

First stage HEAT is approximately 91% of the same second stage HEAT speed position.

First stage COOL (two-stage air conditioning units only) is approximately 70% of the same second stage COOL speed position.

Continuous Fan Only speed is approximately 38% of the same second stage COOL speed position - minimum 500 cfm.

Lennox Harmony III™ Zone Control Applications - Minimum blower speed is 458 cfm.

G61MPV-60C-111 BLOWER MOTOR WATTS

Jumper Speed Positions	Motor Watts @ Various External Static Pressures - in. wg.																		
	First Stage										Second Stage								
	0	0.1	0.2	0.3	0.4	0.5	0.6	0.7	0.8	0	0.1	0.2	0.3	0.4	0.5	0.6	0.7	0.8	
"+" (Plus) SETTING ("Adjust" Jumper at "+" Setting)																			
"HEAT" Speed	Tap 1	210	235	270	300	335	365	395	425	455	275	305	345	380	415	445	475	505	535
	Tap 2	265	305	345	385	425	465	505	545	585	350	395	440	485	530	570	605	645	685
	Tap 3	425	460	490	525	560	590	615	645	675	575	605	640	670	700	730	765	795	800
	Tap 4	540	580	625	665	710	745	780	815	850	730	770	805	845	885	925	965	1005	1015
"COOL" Speed	Tap 1	120	140	165	190	215	235	260	285	305	325	355	390	425	460	490	520	550	580
	Tap 2	145	165	190	215	235	260	290	315	340	390	425	465	500	540	570	600	630	660
	Tap 3	190	220	250	285	320	345	375	400	425	545	585	630	670	715	755	790	830	865
	Tap 4	275	305	340	375	410	440	470	505	535	775	815	860	900	945	975	1010	1040	1060
"NORM" (Normal) SETTING ("Adjust" Jumper at "NORM" Setting)																			
"HEAT" Speed	Tap 1	160	185	215	245	270	295	320	345	370	200	225	260	290	325	355	385	415	445
	Tap 2	205	235	275	310	350	380	410	445	475	255	290	330	375	415	455	490	530	570
	Tap 3	325	350	380	410	440	470	500	530	550	425	455	490	520	555	580	610	635	665
	Tap 4	410	445	480	520	555	595	630	670	700	540	575	620	660	700	735	770	805	840
"COOL" Speed	Tap 1	90	110	135	160	185	200	220	235	260	225	255	290	325	360	390	425	455	485
	Tap 2	105	130	155	180	205	230	250	270	290	295	325	360	395	430	465	495	525	560
	Tap 3	145	165	195	220	250	275	295	320	350	435	465	505	540	575	605	635	665	700
	Tap 4	190	220	250	280	315	345	370	400	430	590	625	665	705	745	790	830	875	905
"-" (Minus) SETTING ("Adjust" Jumper at "-" Setting)																			
"HEAT" Speed	Tap 1	120	140	165	195	220	240	265	290	310	150	175	200	225	250	275	305	330	355
	Tap 2	155	180	215	245	280	310	340	370	395	195	220	255	285	315	355	390	425	455
	Tap 3	240	265	290	320	345	370	395	420	445	315	340	370	395	425	450	475	500	525
	Tap 4	305	335	370	405	440	470	500	535	565	400	430	465	500	535	570	600	630	665
"COOL" Speed	Tap 1	75	90	110	130	150	170	190	215	230	165	190	220	245	275	305	330	360	390
	Tap 2	85	105	125	145	165	190	210	230	255	200	230	260	295	325	355	385	415	445
	Tap 3	115	135	160	185	205	230	250	270	295	305	335	370	405	440	470	505	540	570
	Tap 4	155	175	205	230	260	285	310	335	360	425	460	495	530	570	595	625	655	690

BLOWER DATA

G61MPV-60C-111 BLOWER PERFORMANCE (less filter)

Side Return Air with Optional RAB Return Air Base

0 through 1.00 in. w.g. External Static Pressure Range

"ADJUST" Switch Positions	Speed Switch Positions							
	Second Stage "HEAT" Speed - cfm				Second Stage "COOL" Speed - cfm			
	1	1 2	3	4	1	2	3	1 4
+	1490	1695	1875	2080	1565	1655	1890	2060
¹ NORM	1345	1530	1700	1890	1410	1515	1730	1900
—	1210	1380	1530	1700	1230	1325	1545	1695

"ADJUST" Switch Positions	First Stage "HEAT" Speed - cfm				First Stage "COOL" Speed - cfm			
	1	1 2	3	4	1	2	3	1 4
	+	1365	1555	1730	1925	1090	1155	1335
¹ NORM	1235	1410	1575	1750	995	1060	1190	1335
—	1115	1270	1410	1565	875	935	1070	1200

¹ Factory default jumper setting.

NOTES - The effect of static pressure is included in air volumes shown.

First stage HEAT is approximately 91% of the same second stage HEAT speed position.

First stage COOL (two-stage air conditioning units only) is approximately 70% of the same second stage COOL speed position.

Continuous Fan Only speed is approximately 38% of the same second stage COOL speed position - minimum 500 cfm.

Lennox Harmony III™ Zone Control Applications - Minimum blower speed is 458 cfm.

G61MPV-60C-111 BLOWER MOTOR WATTS

Jumper Speed Positions	Motor Watts @ Various External Static Pressures - in. wg.																		
	First Stage									Second Stage									
	0	0.1	0.2	0.3	0.4	0.5	0.6	0.7	0.8	0	0.1	0.2	0.3	0.4	0.5	0.6	0.7	0.8	
"+" (Plus) SETTING ("Adjust" Jumper at "+" Setting)																			
"HEAT" Speed	Tap 1	165	190	225	255	290	320	355	385	410	210	245	280	320	355	385	410	440	470
	Tap 2	210	245	285	330	370	410	450	490	525	270	310	360	405	455	490	525	560	600
	Tap 3	385	415	445	475	505	535	570	600	625	490	520	560	595	630	660	690	720	745
	Tap 4	490	525	565	600	640	680	720	760	790	620	660	705	750	795	835	870	910	945
"COOL" Speed	Tap 1	115	130	155	180	205	225	250	270	290	310	335	365	390	415	445	470	500	525
	Tap 2	145	160	185	210	230	255	280	305	330	360	390	425	460	495	525	550	580	605
	Tap 3	180	210	240	270	300	330	355	380	405	530	570	615	655	700	735	775	810	845
	Tap 4	265	295	325	360	390	420	450	480	510	715	750	795	835	875	900	930	960	960
"NORM" (Normal) SETTING ("Adjust" Jumper at "NORM" Setting)																			
"HEAT" Speed	Tap 1	140	160	185	205	230	255	285	310	340	155	185	215	250	280	310	340	365	395
	Tap 2	175	205	235	265	295	330	360	395	435	200	235	275	320	360	395	435	470	505
	Tap 3	295	320	350	380	405	430	455	485	505	360	390	425	460	490	520	550	585	610
	Tap 4	375	405	445	480	515	545	580	610	640	460	495	540	580	620	660	700	740	770
"COOL" Speed	Tap 1	85	105	130	150	175	190	210	225	250	200	230	260	295	325	355	385	410	440
	Tap 2	105	125	150	175	200	220	240	265	285	270	300	330	365	395	425	455	485	515
	Tap 3	135	160	185	210	235	260	280	305	330	425	455	490	525	560	590	620	650	685
	Tap 4	180	210	240	270	300	330	355	385	415	545	580	615	651	690	730	770	810	835
"-" (Minus) SETTING ("Adjust" Jumper at "-" Setting)																			
"HEAT" Speed	Tap 1	105	125	150	170	195	220	240	265	285	135	155	175	200	225	250	275	300	325
	Tap 2	135	160	190	220	250	280	310	340	365	170	195	226	255	285	320	350	385	420
	Tap 3	210	230	255	280	305	335	365	395	420	275	300	325	350	375	400	430	455	485
	Tap 4	265	295	325	355	390	425	465	500	530	350	380	410	440	475	510	545	580	610
"COOL" Speed	Tap 1	70	85	105	120	140	160	180	205	220	150	170	195	220	250	275	300	325	350
	Tap 2	85	100	120	140	160	185	205	225	245	195	220	245	270	300	325	355	380	410
	Tap 3	110	130	150	175	195	215	235	255	280	300	330	360	395	430	460	495	530	560
	Tap 4	145	170	195	220	245	270	295	320	345	395	425	455	490	525	550	580	605	635

BLOWER DATA

G61MPV-60C-111 BLOWER PERFORMANCE (less filter)

Single Side Return Air - Air volumes in bold require field fabricated transition to accommodate 20 x 25 x 1 in. cleanable air filter in order to maintain proper air velocity across the filter.

0 through 1.00 in. w.g. External Static Pressure Range

"ADJUST" Switch Positions	Speed Switch Positions							
	Second Stage "HEAT" Speed - cfm				Second Stage "COOL" Speed - cfm			
	1	1 2	3	4	1	2	3	1 4
+	1525	1740	1905	2115	1585	1695	1880	2080
¹ NORM	1370	1560	1720	1915	1430	1555	1725	1915
—	1225	1395	1555	1730	1250	1355	1540	1710
"ADJUST" Switch Positions	First Stage "HEAT" Speed - cfm				First Stage "COOL" Speed - cfm			
	1	1 2	3	4	1	2	3	1 4
	+	1395	1590	1730	1920	1110	1175	1355
¹ NORM	1255	1430	1590	1765	1010	1075	1200	1350
—	1130	1285	1430	1590	895	955	1085	1215

¹ Factory default jumper setting.

NOTES - The effect of static pressure is included in air volumes shown.

First stage HEAT is approximately **91%** of the same second stage HEAT speed position.

First stage COOL (two-stage air conditioning units only) is approximately **70%** of the same second stage COOL speed position.

Continuous Fan Only speed is approximately **38%** of the same second stage COOL speed position - minimum 500 cfm.

Lennox Harmony III™ Zone Control Applications - Minimum blower speed is 458 cfm.

G61MPV-60C-111 BLOWER MOTOR WATTS

Jumper Speed Positions	Motor Watts @ Various External Static Pressures - in. wg.																		
	First Stage									Second Stage									
	0	0.1	0.2	0.3	0.4	0.5	0.6	0.7	0.8	0	0.1	0.2	0.3	0.4	0.5	0.6	0.7	0.8	
"+" (Plus) SETTING ("Adjust" Jumper at "+" Setting)																			
"HEAT" Speed	Tap 1	190	220	250	280	310	345	375	410	430	260	290	320	350	380	415	445	480	510
	Tap 2	245	280	320	360	400	440	480	520	555	335	370	410	445	485	530	570	615	650
	Tap 3	390	425	460	495	530	560	590	615	650	540	580	615	655	695	725	755	785	805
	Tap 4	490	535	580	630	675	710	745	780	820	685	730	780	830	880	920	960	995	1015
"COOL" Speed	Tap 1	120	145	170	195	220	245	270	295	315	315	350	385	420	455	485	515	545	575
	Tap 2	145	165	190	210	235	260	285	310	340	375	410	445	485	520	550	580	610	635
	Tap 3	185	215	250	280	315	340	370	395	420	535	575	615	660	700	740	775	815	845
	Tap 4	280	310	345	375	410	445	475	505	535	755	795	840	880	925	955	985	1015	1015
"NORM" (Normal) SETTING ("Adjust" Jumper at "NORM" Setting)																			
"HEAT" Speed	Tap 1	155	175	200	230	255	275	300	320	350	180	205	240	270	300	330	360	390	420
	Tap 2	200	225	260	290	325	355	385	410	450	230	265	305	345	385	425	460	500	535
	Tap 3	315	340	375	405	440	460	485	510	535	390	425	460	495	530	560	590	615	645
	Tap 4	395	435	475	515	555	585	615	645	675	495	535	580	625	670	705	745	780	815
"COOL" Speed	Tap 1	95	115	140	165	190	205	225	245	270	220	250	285	320	360	390	420	450	480
	Tap 2	105	130	155	180	205	225	250	270	290	285	315	350	380	415	445	475	505	540
	Tap 3	140	165	190	220	245	270	290	315	345	425	460	495	530	565	595	625	655	690
	Tap 4	190	220	250	285	315	345	375	405	435	575	610	650	690	725	770	810	855	885
"-" (Minus) SETTING ("Adjust" Jumper at "-" Setting)																			
"HEAT" Speed	Tap 1	115	135	160	185	210	230	250	270	300	145	165	190	215	235	265	290	315	345
	Tap 2	150	175	205	235	265	295	320	250	385	185	210	245	275	305	335	370	405	440
	Tap 3	235	260	285	310	335	360	380	405	435	295	325	350	380	410	440	470	495	515
	Tap 4	300	330	360	390	420	455	485	515	550	375	410	445	485	520	555	590	630	655
"COOL" Speed	Tap 1	75	90	110	130	150	175	195	220	235	165	185	215	245	275	300	330	355	385
	Tap 2	85	100	125	145	165	185	210	230	250	195	225	255	285	315	340	370	400	430
	Tap 3	115	135	155	180	205	225	245	265	290	300	330	365	395	430	465	495	530	560
	Tap 4	155	180	205	235	260	285	310	340	365	415	450	485	520	555	585	610	640	675

BLOWER DATA

G61MPV-60D-135 BLOWER PERFORMANCE (less filter)

Bottom Return Air, Return Air from Both Sides or Return Air from Bottom and One Side.

0 through 0.80 in. w.g. External Static Pressure Range

"ADJUST" Switch Positions	Speed Switch Positions							
	Second Stage "HEAT" Speed - cfm				Second Stage "COOL" Speed - cfm			
	1	1 2	3	4	1	2	3	1 4
+	1505	1705	1900	2110	1615	1730	1945	2190
¹ NORM	1365	1550	1740	1920	1455	1580	1780	1985
—	1225	1380	1545	1720	1305	1400	1600	1780

"ADJUST" Switch Positions	First Stage "HEAT" Speed - cfm				First Stage "COOL" Speed - cfm			
	1	1 2	3	4	1	2	3	1 4
	+	1385	1570	1760	1930	1135	1205	1365
¹ NORM	1250	1425	1595	1775	1025	1105	1235	1390
—	1135	1265	1430	1585	915	985	1115	1235

¹ Factory default jumper setting.

NOTES - The effect of static pressure is included in air volumes shown.

First stage HEAT is approximately 91% of the same second stage HEAT speed position.

First stage COOL (two-stage air conditioning units only) is approximately 70% of the same second stage COOL speed position.

Continuous Fan Only speed is approximately 38% of the same second stage COOL speed position - minimum 500 cfm.

Lennox Harmony III™ Zone Control Applications - Minimum blower speed is 470 cfm.

G61MPV-60D-135 BLOWER MOTOR WATTS

Jumper Speed Positions	Motor Watts @ Various External Static Pressures - in. wg.																		
	First Stage									Second Stage									
	0	0.1	0.2	0.3	0.4	0.5	0.6	0.7	0.8	0	0.1	0.2	0.3	0.4	0.5	0.6	0.7	0.8	
"+" (Plus) SETTING ("Adjust" Jumper at "+" Setting)																			
"HEAT" Speed	Tap 1	155	185	220	255	285	315	340	365	390	215	225	265	305	335	365	400	435	465
	Tap 2	215	250	285	325	360	390	425	455	490	275	315	360	400	440	475	505	540	575
	Tap 3	315	350	390	430	460	490	530	565	605	405	440	475	515	550	585	630	670	715
	Tap 4	435	465	500	530	575	615	655	695	735	530	575	620	670	725	780	825	870	915
"COOL" Speed	Tap 1	95	120	145	170	190	215	240	265	290	250	285	320	360	390	420	450	485	515
	Tap 2	115	135	160	185	210	235	260	290	315	290	330	375	420	455	490	525	565	605
	Tap 3	145	175	215	250	275	300	330	355	385	425	465	505	550	590	635	670	710	750
	Tap 4	205	240	280	320	350	380	410	445	480	615	655	700	745	800	855	900	940	980
"NORM" (Normal) SETTING ("Adjust" Jumper at "NORM" Setting)																			
"HEAT" Speed	Tap 1	130	155	180	205	235	260	285	305	330	155	180	210	245	270	300	330	355	385
	Tap 2	165	195	230	265	300	330	360	385	415	215	250	295	335	360	385	420	455	490
	Tap 3	240	270	310	345	380	415	440	470	500	305	340	380	420	455	490	520	545	575
	Tap 4	335	365	405	440	480	515	550	585	620	405	445	485	530	570	610	650	690	735
"COOL" Speed	Tap 1	80	95	115	135	160	190	210	230	255	185	215	245	280	310	335	370	400	430
	Tap 2	90	115	140	165	190	215	230	250	265	230	260	295	335	370	405	435	470	500
	Tap 3	130	150	170	195	225	255	275	300	320	315	355	400	445	480	515	555	590	625
	Tap 4	150	180	220	255	285	315	345	375	405	445	485	530	580	625	670	705	740	775
"-" (Minus) SETTING ("Adjust" Jumper at "-" Setting)																			
"HEAT" Speed	Tap 1	100	120	140	165	190	215	240	265	290	125	150	175	200	225	245	270	295	320
	Tap 2	130	155	180	210	235	265	285	310	330	155	185	215	250	280	305	335	365	395
	Tap 3	170	200	235	270	300	330	360	390	420	220	250	280	315	350	390	425	460	490
	Tap 4	225	260	300	335	375	410	435	465	490	295	325	360	395	435	470	505	545	580
"COOL" Speed	Tap 1	65	80	100	120	140	160	180	195	215	145	170	195	225	250	280	305	330	355
	Tap 2	70	90	110	130	155	175	200	220	240	160	190	225	255	285	315	345	380	415
	Tap 3	95	120	145	170	190	215	235	250	270	245	280	315	355	385	415	445	480	515
	Tap 4	135	155	175	200	220	245	270	300	325	325	365	405	445	485	520	550	580	610

BLOWER DATA

G61MPV-60D-135 BLOWER PERFORMANCE (less filter)

Single Side Return Air - Air volumes in bold require field fabricated transition to accommodate 20 x 25 x 1 in. cleanable air filter in order to maintain proper air velocity across the filter.

0 through 0.80 in. w.g. External Static Pressure Range

"ADJUST" Switch Positions	Speed Switch Positions							
	Second Stage "HEAT" Speed - cfm				Second Stage "COOL" Speed - cfm			
	1	1 2	3	4	1	2	3	1 4
+	1470	1650	1845	2040	1585	1705	1905	2130
¹ NORM	1325	1495	1680	1865	1430	1545	1765	1975
—	N/A	1335	1505	1670	1275	1370	1565	1755
"ADJUST" Switch Positions	First Stage "HEAT" Speed - cfm				First Stage "COOL" Speed - cfm			
	1	1 2	3	4	1	2	3	1 4
	+	1335	1510	1695	1870	1105	1180	1330
¹ NORM	1210	1370	1540	1710	990	1075	1210	1355
—	N/A	1225	1375	1515	890	950	1085	1210

¹ Factory default jumper setting.

N/A - First and second stage HEAT positions shown cannot be used on this model.

NOTES - The effect of static pressure is included in air volumes shown.

First stage HEAT is approximately **91%** of the same second stage HEAT speed position.

First stage COOL (two-stage air conditioning units only) is approximately **70%** of the same second stage COOL speed position.

Continuous Fan Only speed is approximately **38%** of the same second stage COOL speed position - minimum 500 cfm.

Lennox Harmony III™ Zone Control Applications - Minimum blower speed is 470 cfm.

G61MPV-60D-135 BLOWER MOTOR WATTS

Jumper Speed Positions	Motor Watts @ Various External Static Pressures - in. wg.																		
	First Stage									Second Stage									
	0	0.1	0.2	0.3	0.4	0.5	0.6	0.7	0.8	0	0.1	0.2	0.3	0.4	0.5	0.6	0.7	0.8	
"+" (Plus) SETTING ("Adjust" Jumper at "+" Setting)																			
"HEAT" Speed	Tap 1	150	175	210	240	270	300	330	360	390	180	215	255	295	330	365	400	430	465
	Tap 2	205	235	275	310	355	395	430	465	500	275	315	360	400	435	470	510	550	585
	Tap 3	315	345	385	420	460	495	535	570	610	415	450	490	525	565	600	640	675	715
	Tap 4	430	460	495	530	575	620	665	705	750	535	585	640	695	730	765	810	860	905
"COOL" Speed	Tap 1	90	110	140	170	195	220	240	265	290	230	265	310	355	390	425	460	490	525
	Tap 2	105	130	165	195	215	235	260	290	315	285	330	380	430	455	485	525	565	605
	Tap 3	150	175	205	235	270	300	330	360	385	425	465	515	560	605	645	685	730	770
	Tap 4	195	230	270	305	340	375	410	445	480	605	650	695	740	800	855	900	945	985
"NORM" (Normal) SETTING ("Adjust" Jumper at "NORM" Setting)																			
"HEAT" Speed	Tap 1	120	140	170	200	225	255	280	305	330	150	175	210	240	270	300	335	365	400
	Tap 2	155	185	220	255	295	335	365	395	425	205	240	275	315	350	385	422	460	495
	Tap 3	235	265	300	330	370	405	440	470	500	290	330	380	430	460	485	515	545	575
	Tap 4	320	355	390	430	465	505	540	575	610	395	440	485	530	575	620	660	700	740
"COOL" Speed	Tap 1	70	90	115	135	165	190	210	230	245	170	200	235	265	305	345	380	420	455
	Tap 2	80	100	130	160	185	210	230	255	275	245	270	305	335	370	410	440	470	505
	Tap 3	120	140	170	195	225	255	280	305	330	350	385	420	455	495	530	570	610	645
	Tap 4	145	175	215	250	280	315	345	375	410	455	500	555	605	645	680	725	770	810
"-" (Minus) SETTING ("Adjust" Jumper at "-" Setting)																			
"HEAT" Speed	Tap 1	N/A	N/A	N/A	N/A	N/A	N/A	N/A	N/A	N/A	N/A	N/A	N/A	N/A	N/A	N/A	N/A	N/A	N/A
	Tap 2	125	150	175	195	230	265	290	310	335	150	175	210	240	255	290	330	370	405
	Tap 3	155	185	215	250	285	320	355	385	420	205	235	270	305	345	380	420	455	490
	Tap 4	205	240	285	325	355	385	420	460	495	290	325	360	400	440	480	515	545	580
"COOL" Speed	Tap 1	60	75	95	115	135	150	175	195	220	140	160	185	205	240	280	305	335	360
	Tap 2	60	75	100	125	150	175	195	215	235	145	180	215	250	290	325	355	385	420
	Tap 3	90	110	140	165	190	215	235	255	270	230	265	305	345	380	420	450	480	510
	Tap 4	120	140	170	195	225	255	275	300	325	330	365	405	445	485	525	560	595	635

BLOWER DATA

G61MPV-60D-135 BLOWER PERFORMANCE (less filter)

Side Return Air with Optional RAB Return Air Base

0 through 0.80 in. w.g. External Static Pressure Range

"ADJUST" Switch Positions	Speed Switch Positions							
	Second Stage "HEAT" Speed - cfm				Second Stage "COOL" Speed - cfm			
	1	1 2	3	4	1	2	3	1 4
+	1445	1635	1825	2025	1550	1660	1875	2105
¹ NORM	1305	1475	1660	1840	1400	1510	1720	1920
—	N/A	1315	1480	1650	1250	1345	1530	1715

"ADJUST" Switch Positions	First Stage "HEAT" Speed - cfm				First Stage "COOL" Speed - cfm			
	1	1 2	3	4	1	2	3	1 4
	+	1315	1490	1675	1855	1080	1155	1310
¹ NORM	1195	1365	1530	1695	985	1055	1190	1325
—	N/A	1210	1360	1500	875	945	1060	1190

¹ Factory default jumper setting.

N/A - First and second stage HEAT positions shown cannot be used on this model.

NOTES - The effect of static pressure is included in air volumes shown.

First stage HEAT is approximately 91% of the same second stage HEAT speed position.

First stage COOL (two-stage air conditioning units only) is approximately 70% of the same second stage COOL speed position.

Continuous Fan Only speed is approximately 38% of the same second stage COOL speed position - minimum 500 cfm.

Lennox Harmony III™ Zone Control Applications - Minimum blower speed is 470 cfm.

G61MPV-60D-135 BLOWER MOTOR WATTS

Jumper Speed Positions	Motor Watts @ Various External Static Pressures - in. wg.																		
	First Stage									Second Stage									
	0	0.1	0.2	0.3	0.4	0.5	0.6	0.7	0.8	0	0.1	0.2	0.3	0.4	0.5	0.6	0.7	0.8	
"+" (Plus) SETTING ("Adjust" Jumper at "+" Setting)																			
"HEAT" Speed	Tap 1	145	175	205	235	265	295	325	355	385	195	225	260	290	330	370	400	435	470
	Tap 2	205	235	270	305	340	375	415	450	485	275	310	355	400	430	460	495	535	570
	Tap 3	285	325	370	410	450	490	525	565	600	420	445	470	495	545	590	630	675	715
	Tap 4	385	430	480	530	570	610	650	690	725	535	580	625	670	710	755	800	845	890
"COOL" Speed	Tap 1	90	110	140	165	190	210	235	260	285	235	265	305	340	380	415	450	480	515
	Tap 2	105	130	160	190	210	230	255	285	310	290	325	370	410	450	490	515	545	575
	Tap 3	145	170	205	235	265	290	325	355	390	420	460	510	555	595	640	680	715	755
	Tap 4	200	230	270	305	345	385	415	445	480	580	630	690	745	800	850	895	935	975
"NORM" (Normal) SETTING ("Adjust" Jumper at "NORM" Setting)																			
"HEAT" Speed	Tap 1	130	150	170	190	225	260	285	305	330	150	175	205	235	265	295	325	355	385
	Tap 2	160	190	225	260	290	325	355	390	420	200	230	265	300	345	385	410	440	465
	Tap 3	235	265	300	335	370	400	435	470	500	290	330	375	415	450	485	515	540	570
	Tap 4	310	350	390	435	470	500	540	575	610	405	440	485	525	560	590	635	680	725
"COOL" Speed	Tap 1	70	90	115	140	165	190	210	230	250	170	200	235	270	305	335	370	400	430
	Tap 2	90	105	125	150	175	200	225	250	270	200	230	270	310	355	400	435	465	495
	Tap 3	115	140	170	195	225	250	275	300	325	330	365	400	440	485	525	555	585	615
	Tap 4	145	175	205	240	270	295	330	365	395	435	480	530	580	625	675	715	750	790
"-" (Minus) SETTING ("Adjust" Jumper at "-" Setting)																			
"HEAT" Speed	Tap 1	N/A	N/A	N/A	N/A	N/A	N/A	N/A	N/A	N/A	N/A	N/A	N/A	N/A	N/A	N/A	N/A	N/A	N/A
	Tap 2	125	145	170	195	225	255	280	300	325	150	175	210	240	265	290	325	365	400
	Tap 3	160	190	220	250	285	320	350	380	410	200	230	270	305	350	395	420	445	475
	Tap 4	200	235	275	310	355	395	425	460	490	285	320	355	395	435	475	510	545	580
"COOL" Speed	Tap 1	60	75	95	115	135	155	175	195	215	135	155	180	205	240	280	305	330	355
	Tap 2	70	90	110	130	150	170	195	215	235	160	185	215	240	275	310	345	375	410
	Tap 3	85	105	130	155	180	205	230	250	270	220	255	295	335	370	410	440	475	510
	Tap 4	120	140	170	195	220	240	270	295	325	330	365	400	440	480	525	555	585	615

REVISIONS

Sections	Description of Change
Optional Accessories Table/ Gas Heating Accessories	Updated High Altitude Orifice Kits, Natural to LPG Conversion Kits and LPG to Natural Conversion Kits
Features Optional Accessories Termination Kit Equivalent Vent Lengths Dimensions	Updated information on Concentric and Close Couple Wall Kits
Dimensions	Changed height on cased, CX34-19A, CX34-25A/B, CX34-31A/B, CX34-43B/C, CX34-62C



LENNOX

Visit us at www.lennox.com

For the latest technical information, www.lennox.com

Contact us at 1-800-4-LENNOX

NOTE - Due to Lennox' ongoing commitment to quality, Specifications, Ratings and Dimensions subject to change without notice and without incurring liability. Improper installation, adjustment, alteration, service or maintenance can cause property damage or personal injury. Installation and service must be performed by a qualified installer and servicing agency.

©2008 Lennox Industries Inc.