



**LCH**

**Energence® Ultra-High Efficiency Rooftop Units**

**60 Hz**

**COMMERCIAL  
PRODUCT SPECIFICATIONS**

Bulletin No. 210763

March 2021

Supersedes July 2019

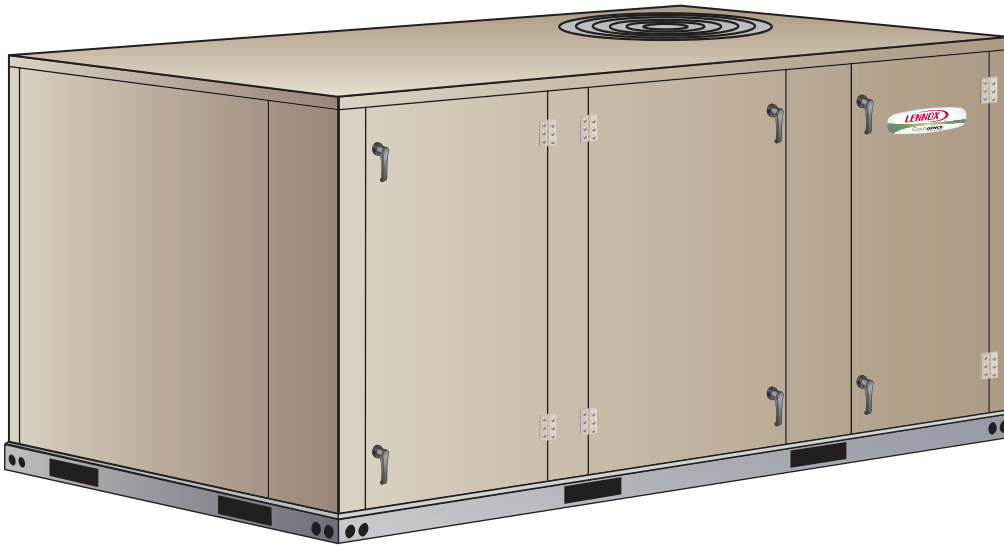

**SMARTWIRE™ SYSTEM**



**ASHRAE 90.1  
COMPLIANT**



**3 to 6 Tons  
Net Cooling Capacity - 34,500 to 70,000 Btuh  
Optional Electric Heat - 7.5 to 22.5 kW**

**MODEL NUMBER IDENTIFICATION**

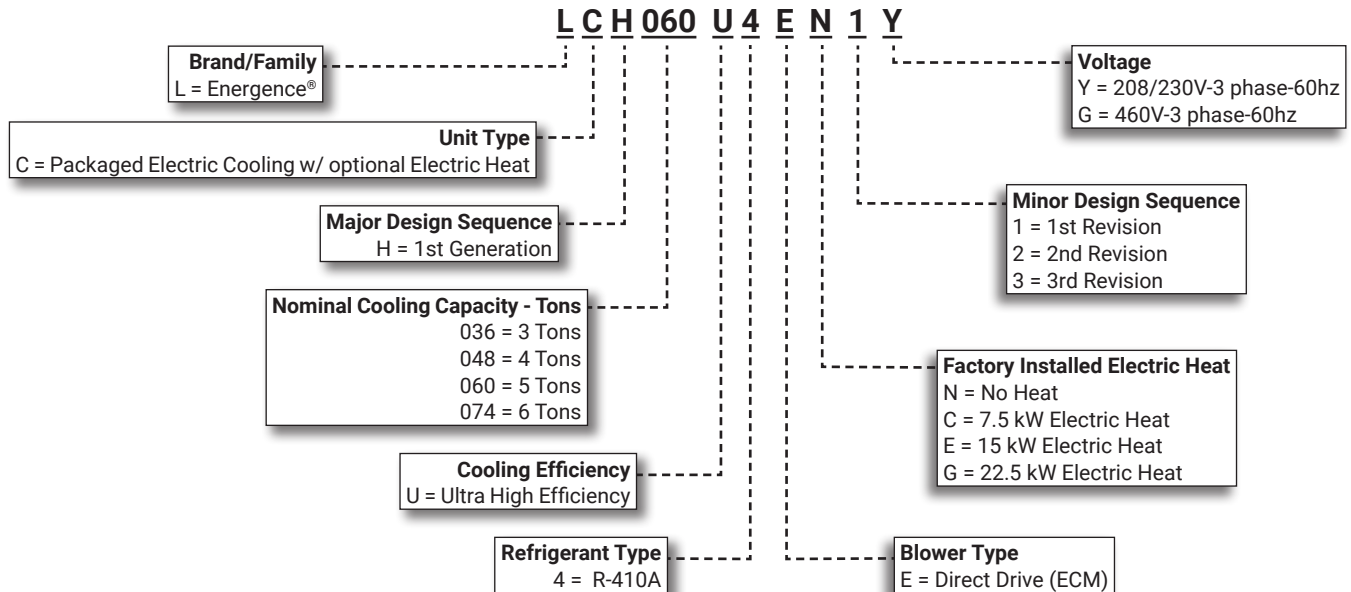

## FEATURE HIGHLIGHTS

Lennox' Emergence® Ultra-High Efficiency rooftop unit product line was created to save energy with intelligence by offering some of the highest energy efficiency ratings available with a powerful, easy to use unit controller. This makes Emergence rooftop units perfect for business owners looking for an HVAC product with the lowest total cost of ownership.

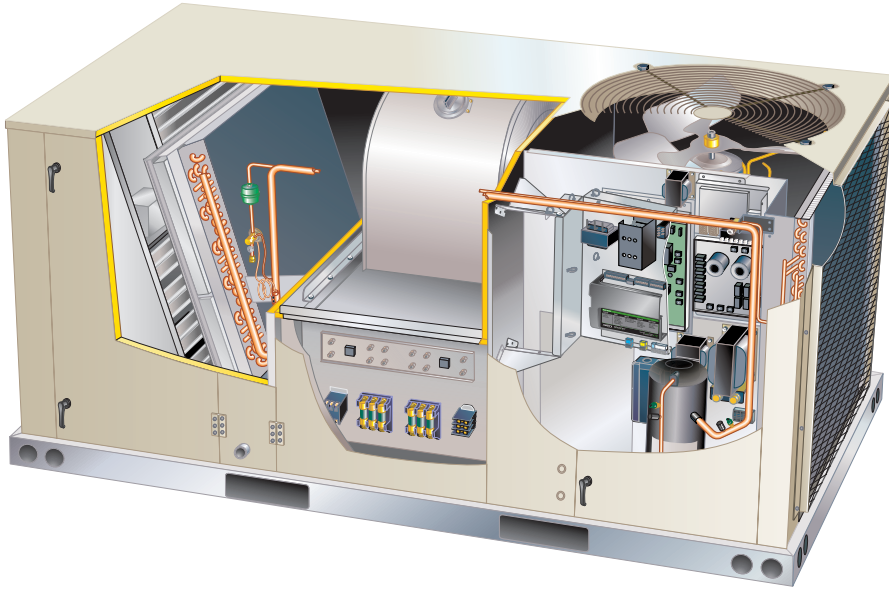

1. Variable Capacity Scroll Compressor
2. DC Inverter Control
3. Filter/Drier
4. Condenser Coil
5. Variable-Speed ECM Outdoor Coil Fan Motor
6. Heavy Gauge Steel Cabinet
7. Hinged Access Panels
8. Supply Air Blower
9. Electric Heat (option)
10. Air Filters
11. Prodigy 2.0 Control System
12. Economizer (option)

## CONTENTS

Approvals And Warranty . . . . .	3
Blower Data . . . . .	21
Dimensions - Unit . . . . .	31
Electrical / Electric Heat Data . . . . .	25
Electric Heat Capacities . . . . .	29
Feature Highlights . . . . .	2
Features And Benefits . . . . .	3
Model Number Identification. . . . .	1
Optional Conventional Temperature Control Systems . . . . .	11
Options / Accessories . . . . .	13
Outdoor Sound Data . . . . .	29
Ratings . . . . .	17
Specifications . . . . .	16
Unit Clearances . . . . .	29
Weight Data . . . . .	30

## APPROVALS AND WARRANTY

### APPROVALS

- AHRI Certified to AHRI Standard 210/240 (3 thru 5 ton models) and AHRI Standard 340/360 (6 ton models)
- ETL listed
- Efficiency rating certified by CSA
- Components bonded for grounding to meet safety standards for servicing required by UL, ULC and National and Canadian Electrical Codes
- All models are ASHRAE 90.1 compliant
- ENERGY STAR® certified units are designed to use less energy, help save money on utility bills, and help protect the environment
- ISO 9001 Registered Manufacturing Quality System

### WARRANTY

- Compressors - Limited five years
- Prodigy® 2.0 Unit Controller - Limited three years
- High Performance Economizers (optional) - Limited five years
- All other covered components - Limited one year

## FEATURES AND BENEFITS

### COOLING SYSTEM

- Designed to maximize sensible and latent cooling performance at design conditions
- System can operate from 0°F to 125°F without any additional controls

#### R-410A Refrigerant

- Non-chlorine based
- Ozone friendly

#### 1 Variable Capacity Scroll Compressor

- Operates on a variable frequency
- DC Inverter Control varies the capacity based on the cooling load required
- High volumetric efficiency
- Uniform suction flow
- Constant discharge flow
- Quiet operation

#### Compressor Operation

- Two involute spiral scrolls matched together to generate a series of crescent shaped gas pockets between them
- During compression, one scroll remains stationary while the other scroll orbits around it
- Gas is drawn into the outer pocket, the pocket is sealed as the scroll rotates
- As the spiral movement continues, gas pockets are pushed to the center of the scrolls
- Volume between the pockets is simultaneously reduced
- When the pocket reaches the center, gas is now at high pressure and is forced out of a port located in the center of the fixed scrolls
- During compression, several pockets are compressed simultaneously resulting in a smooth continuous compression cycle
- Continuous flank contact, maintained by centrifugal force, minimizes gas leakage and maximizes efficiency

- Compressor is tolerant to the effects of slugging and contaminants
- If this occurs, scrolls separate, allowing liquid or contaminants to be worked toward the center and discharged

#### Top Cap Thermal Sensor Switch

- Located on top of the compressor casing
- Discontinues compressor operation in case of abnormal operating conditions

#### Crankcase Heater

- Prevents migration of liquid refrigerant into compressor
- Ensures proper compressor lubrication

#### 2 DC Inverter Control

- Converts AC line voltage into filtered variable DC voltage
- Provides continuous compressor operation, while adjusting the capacity according to indoor temperature
- Adjusts compressor output in increments as small as 1%
- Prevents frequent changes in capacity and ensures efficient, economical operation
- Power Factor Correction (PFC) circuit monitors the DC bus for high, low and abnormal voltage conditions to protect the compressor
- Two LEDs (red and green) indicate inverter operating status and aid in troubleshooting
- Noise filter reduces unwanted electromagnetic interference (EMI)
- Inverter reactor adds inductance to the line between the inverter and the compressor to limit current rise and protect the compressor

#### 3 Filter/Drier

- High capacity filter/drier protects the system from dirt and moisture

## FEATURES AND BENEFITS

### COOLING SYSTEM (continued)

#### High Pressure Switch

- Protects the compressor from overload conditions such as dirty condenser coils, blocked refrigerant flow, or loss of outdoor fan operation

#### Low Pressure Switch

- Protects the compressor from low pressure conditions such as low refrigerant charge, or low/no airflow

#### Freezestat

- Protects the evaporator coil from damaging ice build-up due to conditions such as low/no airflow, or low refrigerant charge

#### 4 Condenser Coil

- Copper tube construction
- Enhanced rippled-edge aluminum fins
- Flared shoulder tubing connections
- Silver soldered construction

#### Evaporator Coil

- Copper tube construction
- Enhanced rippled-edge aluminum fins
- Flared shoulder tubing connections
- Silver soldered construction
- Factory leak tested
- Cross row circuiting with rifled tubing

#### Condensate Drain Pan

- Plastic pan, sloped to meet drainage requirements per ASHRAE 62.1
- Side or bottom drain connections
- Reversible to allow connection at back of unit

#### 5 Variable-Speed ECM Outdoor Coil Fan Motors

- Fan speed is directly controlled by the Prodigy 2.0 unit controller
- Thermal overload protected
- Totally enclosed
- Permanently lubricated ball bearings
- Shaft up
- Wire basket mount

#### Outdoor Coil Fans

- PVC coated fan guard furnished

### Required Selections

#### Cooling Capacity

- Specify nominal cooling capacity

### Options/Accessories

#### Factory Installed

#### Service Valves

- Fully serviceable brass valves installed in discharge & liquid lines

#### Factory Installed

#### Condensate Drain Trap

- Available in copper or PVC
- Field installed, may be factory enclosed to ship with unit

#### Drain Pan Overflow Switch

- Monitors condensate level in drain pan
- Shuts down unit if drain becomes clogged

### CABINET

#### 6 Construction

- Heavy-gauge steel panels and full perimeter heavy-gauge galvanized steel base rail provides structural integrity for transportation, handling, and installation
- Base rails have rigging holes
- Three sides of the base rail have forklift slots
- Raised edges around duct and power entry openings in the bottom of the unit provide additional protection against water entering the building

#### Airflow Choice

- Units are shipped in downflow (vertical) configuration
- Can be field converted to horizontal airflow configuration without any optional kits

#### Duct Flanges

- Provided for horizontal duct attachment

#### Power Entry

- Electrical lines can be brought through the unit base or through horizontal access knock-outs

#### Exterior Panels

- Constructed of heavy-gauge, galvanized steel with a two-layer enamel paint finish

#### Insulation

- All panels adjacent to conditioned air are fully insulated with non-hygroscopic fiberglass insulation
- Unit base is fully insulated
- Base Insulation serves as an air seal to the roof curb, eliminating the need to add a seal during installation

#### 7 Access Panels

- Tool-less access
- Economizer/filter section
- Blower/heating section
- Compressor/controls section
- Panel seals and quarter-turn latching handles provide a tight air and water seal

**NOTE** - Optional Economizers, Power Exhaust, Outdoor Air Dampers and Barometric Relief Dampers for all models include a filler panel for proper cabinet fit.

### Required Selections

#### Airflow Configuration

- Specify horizontal or downflow

## FEATURES AND BENEFITS

### **CABINET (continued)**

#### Options/Accessories

#### **Factory Installed**

##### **Corrosion Protection**

- Completely flexible immersed coating with an electrodeposited dry film process (AST ElectroFin E-Coat)
- Meets Mil Spec MIL-P-53084, ASTM B117 Standard Method Salt Spray Testing
- Indoor Corrosion Protection:
  - Coated coil
  - Painted blower housing
  - Painted base
- Outdoor Corrosion Protection:
  - Coated coil
  - Painted base

#### **Field Installed**

##### **Combination Coil/Hail Guards**

- Heavy gauge steel frame
- Painted to match cabinet
- Expanded metal mesh protects outdoor coil

### **BLOWER**

#### **Direct Drive ECM Motor**

- High-efficiency
- Variable-speed ECM (electronically commutated) motor
- Maintains the ability to ramp the blower up or down to meet comfort needs
- The amount of airflow for each stage can be set according to a parameter in the Prodigy 2.0 unit controller
- Unit is shipped from the factory with preset airflow

#### **Airflow Management**

- Allows the installer to directly enter the design-specified supply air (blower) parameters without the need to manually take measurements and adjust settings
- Monitors supply air volume as well as customizable diagnostics

#### **8 Supply Air Blower**

- Forward curved blades
- Blower wheel is statically and dynamically balanced

#### **Ordering Information**

- Specify motor output when base unit is ordered

### **ELECTRICAL**

#### **SmartWire™ System**

- Keyed and color-coded wiring connectors prevent miswiring
- Wire coloring scheme is standardized across all models
- Each connection is intuitively labeled to make troubleshooting and servicing quick and easy

#### **Electrical Plugs**

- Positive connection electrical plugs are used to connect common accessories or maintenance parts for easy removal or installation

#### Required Selections

#### **Voltage Choice**

- Specify when ordering base unit

#### Options/Accessories

#### **Factory Installed**

##### **Circuit Breakers**

- HACR type
- For overload and short circuit protection
- Factory wired and mounted in the power entry panel
- Current sensitive and temperature activated
- Manual reset

##### **SCR (Silicon Controlled Rectifier) Electric Heat Control**

- Modulates small, precise increments of power to the electric heat load eliminating temperature fluctuations associated with mechanical controls
- Almost instantaneous operation with no moving parts
- Zero-Cross (fast cycling) feature improves electric heater life with less contraction and expansion of the heating elements
- Operates when there is no call for heat from the building control system or thermostat
- SCR air tempering is controlled by a secondary thermostat and remote duct sensor (order separately)
- A call for heat overrides the SCR and modulates the SCR to 100% heat output
- A call for cooling also overrides the SCR
- Available for all voltages and electric heat sizes

**NOTE** - Blower Proving Switch is required and must be ordered separately for factory installation. See Controls in the Options/Accessories table.

**NOTE** - Available for use with conventional thermostat controls or Novar® control systems only.

##### **Short-Circuit Current Rating (SCCR)**

- Higher short circuit protection up to 100kA

## FEATURES AND BENEFITS

### **ELECTRICAL (continued)**

#### **Factory or Field Installed**

##### **Disconnect Switch**

- Accessible from outside of unit
- Spring loaded weatherproof cover furnished

#### **9 Electric Heat**

- Helix wound nichrome elements
- Individual element limit controls
- Wiring harness
- Unit fuse block
- See Options / Accessories tables for ordering information

#### **GFI Service Outlets (2)**

- 115V ground fault circuit interrupter (GFCI) type
- Non-powered
- Field-wired

#### **Field Installed**

##### **GFI Weatherproof Cover**

- Single-gang cover
- Heavy-duty UV-resistant polycarbonate case construction
- Hinged base cover with gasket

### **INDOOR AIR QUALITY**

#### **10 Air Filters**

- Disposable 2 inch filters furnished as standard

#### **Options/Accessories**

#### **Factory or Field Installed**

##### **Healthy Climate® High Efficiency Air Filters**

- Disposable MERV 8 or MERV 13 (Minimum Efficiency Reporting Value based on ASHRAE 52.2) efficiency 2-inch pleated filters

#### **Field Installed**

##### **Healthy Climate® UVC Germicidal Lamps**

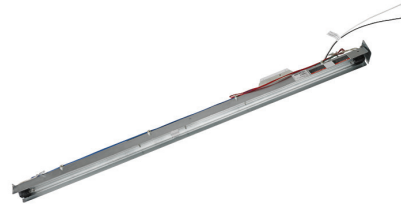

- Germicidal lamps emit ultra-violet (UV-C) energy, which has been proven to be effective in reducing microbes such as viruses, bacteria, yeasts, and molds
- This process either destroys the organism or controls its ability to reproduce
- UV-C energy greatly reduces the growth and proliferation of mold and other bioaerosols (bacteria and viruses) on illuminated surfaces (particularly coil and drain pan)
- Field installed in the blower/evaporator coil section
- Magnetic safety interlock terminates power when access panels are removed
- All necessary hardware for installation is included
- Lamps operate on 110/230V, 1 phase power supply

**NOTE** - Step-down transformer may be ordered separately for 460V and 575V units.

- Approved by ETL

##### **Indoor Air Quality (CO<sub>2</sub>) Sensors**

- Monitors CO<sub>2</sub> levels
- Reports to the Prodigy 2.0 Unit Controller, which adjusts economizer dampers as needed

## CONTROL SYSTEM

### PRODIGY CONTROL SYSTEM



**11** The Prodigy 2.0 unit controller is a microprocessor-based controller that provides flexible control of all unit functions.

#### Features:

- LCD Display
- Easy to read menu (4 lines x 20 character display)
- Buttons for menu navigation during setup and diagnostic
- Menu navigation LEDs for Data, Setup, Service, Settings
- Main Menu and Help Buttons for quick navigation to home screen and built-in help functions
- Scroll, Value Adjustment Select and Save Buttons
- Setup menu ensures proper installation and simplified setup of the rooftop unit
- Profile setup copies key settings between units with the same configuration to reduce setup time
- USB port allows a technician to download and transfer unit information to help verify service was performed
- USB software updates on the Control System enhance functionality without the need to change components
- Unit Controller Software
- Unit self-test verifies individual critical component and system performance
- Economizer test function assures economizer is operating correctly
- Time Clock with Run-Time Information

#### Built-In Functions Include:

- Adjustable Blower On/Off Delay
- Built-in Control Parameter Defaults
- Compressor Time-Off Delay
- DDC Compatible
- Dirty Filter Switch Input
- Discharge Air Temperature Control
- Display/Sensor Readout
- Economizer Control Options (See Economizer / Exhaust Air / Outdoor Air sections)
- Fresh Air Tempering
- Over 100 diagnostic and status messages in English
- Exhaust Fan Control Modes for fresh air damper position
- Permanent Diagnostic Code Storage
- Field Adjustable Control Parameters (Over 200 settings)
- Indoor Air Quality Input (Demand Control Ventilation)
- Low Ambient Controls for cooling operation down to 0°F
- Gas Valve Time Delay Between First and Second Stage

- Minimum Compressor Run Time
- Network Capable (Can be daisy chained to other units or controls)
- Night Setback Mode
- Return Air Temperature Limit Control
- Safety Switch Input allows Controller to respond to a external safety switch trip
- Service Relay Output
- Smoke Alarm Mode has four choices (unit off, positive pressure, negative pressure, purge)
- Up to 2 heat/2 cool (standard unit controller thermostat input)
- Up to 3 cool with additional relay
- Up to 4 cool with room sensor or network operation
- "Strike Three" Protection
- Alternate Humidity Control Options allow simultaneous heating and cooling operation for humidity control of process air applications such as supermarkets
- Thermostat Bounce Delay
- Warm Up Mode Delay
- LED Indicators
- PC Interface connects the Prodigy 2.0 unit controller to a PC with the Lennox Unit Controller Software
- Room Sensor Operation controls temperature

**NOTE** - Prodigy® Control System features vary with the type of rooftop unit in which the control is installed.

**NOTE** - See separate Prodigy® Control System Product Specifications Bulletin for additional information.

#### Increased Dehumidification Mode

- Prodigy® 2.0 Unit Controller operates the compressor, indoor blower, and outdoor fan with full variability to more accurately and efficiently match the humidity load in the space

## CONTROL SYSTEM

### PRODIGY CONTROL SYSTEM (continued)

#### Controls Options

##### Factory or Field Installed

###### Dirty Filter Switch

- Senses static pressure increase

###### Fresh Air Tempering

- Used in applications with high outside air requirements
- Controller energizes the first stage heat as needed to maintain a minimum supply air temperature for comfort, regardless of the thermostat demand
- When ordered as a factory option, sensor ships with the unit for field installation

###### Smoke Detector

- Photoelectric type
- Installed in supply air section, return air section or both sections
- Available with power board and single sensor (supply or return) or power board and two sensors (supply and return)
- Power board located in unit control compartment

###### Interoperability via BACnet® or LonTalk® Protocols

- Communication compatible with third-party automation systems that support the BACnet Application Specific Controller device profile, LonMark® Space Comfort Controller functional profile, or LonMark Discharge Air Controller functional profile

##### Commercial Control Systems

###### L Connection® Network Control System

- Complete building automation control system for single or multi-zone applications
- Options include local interface, software for local or remote communication, and hardware for networking other control functions
- See L Connection Network Control System Product Specifications Bulletin for details

###### After-Market DDC

- Novar® Unit Controller and options

###### Thermostats

- Control system and thermostat options, see page 11
- After-Market unit controller options

##### Field Installed

###### General Purpose Control Kit

- Plug-in control provides additional analog and digital inputs/outputs for field installed options

## OPTIONS / ACCESSORIES

### ECONOMIZER

- 12 • Economizer operation is set and controlled by the Prodigy 2.0 Unit Controller

- Simple plug-in connections from economizer to unit controller for easy installation
- All Emergence® rooftop units are equipped with factory installed CEC Title 24 approved sensors for outside, return and discharge air temperature monitoring

**NOTE** - Optional sensors may be used instead of unit sensors to determine whether outdoor air is suitable for free cooling. See Options/Accessories table.

##### Factory or Field Installed

###### High Performance Economizer

- Approved for California Title 24 building standards
- Low leakage dampers are Air Movement and Control Association International (AMCA) Class 1A Certified - Maximum 3 CFM per sq. ft. leakage at 1 in. w.g.
- ASHRAE 90.1 compliant
- Combination Outdoor Air Hood is furnished
- Factory installed Economizer can be ordered with three exhaust options:

- Barometric Relief Dampers
- Power Exhaust Fan

**NOTE** - See Power Exhaust Fan section for additional requirements.

- No Exhaust
- Field installed Economizer includes Barometric Relief Dampers with Combination Hood
- Barometric Relief Dampers allow relief of excess air
- Dampers prevent blow back and outdoor air infiltration during off cycle
- Bird screen furnished

**NOTE** - Barometric Relief Dampers are required when Economizer is factory installed with factory installed Power Exhaust Fan option. See Power Exhaust Fan section and Options/Accessories table.

**NOTE** - Horizontal Barometric Dampers are required for horizontal Economizer applications and must be ordered separately.

- Demand Control Ventilation (DCV) ready using optional CO<sub>2</sub> sensors
- Gear-driven action
- High torque 24-volt
- Fully-modulating spring return damper motor
- Return air and outdoor air dampers
- Plug-in connections to unit
- Nylon bearings
- Enhanced thermoplastic vulcanizate (TPV) seals
- Flexible stainless steel jamb seals to minimize air leakage



## OPTIONS / ACCESSORIES

### **ECONOMIZER (continued)**

#### **Factory or Field Installed (continued)**

**NOTE** - High Performance Economizers are not approved for use with enthalpy controls in Title 24 applications.

**NOTE** - The Free Cooling setpoint for Title 24 applications must be set based on the Climate Zone where the system is installed. See Section 140.4 "Prescriptive Requirements for Space Conditioning Systems" of the California Energy Commission's 2013 Building Energy Efficiency Standards.

**NOTE** - Refer to Installation Instructions for complete setup information.

#### **Differential Sensible Control**

- Factory setting
- Uses outdoor air and return air sensors that are furnished with the unit
- The Prodigy 2.0 unit controller compares outdoor air and return air and using setpoints
- Enables the economizer when the outdoor air temperature is below the configured setpoint and cooler than return air

**NOTE** - Differential Sensible Control can be configured in the field to provide Offset Differential Sensible Control or Single Sensible Control.

In Offset Differential Sensible Control mode, the economizer is enabled if the temperature differential (offset) between outdoor air and return air reaches the configured setpoint.

In Single Sensible Control mode, the economizer is enabled when outdoor air temperature falls below the configured setpoint.

#### **Global Control**

- The unit controller communicates with a DDC system with one global sensor (enthalpy or sensible) to determine whether outside air is suitable for free cooling on all units connected to the control system
- Sensor must be field provided

**NOTE** - Global control with enthalpy is not approved for Title 24 applications.

#### **Single Enthalpy Temperature Control (Not for Title 24)**

- Outdoor air enthalpy sensor enables Economizer if the outdoor enthalpy is less than the setpoint of the control

#### **Differential Enthalpy Control (Not for Title 24)**

- Order two Single Enthalpy Controls:
  - One is field installed in the return air section
  - One in the outdoor air section
- Allows the economizer control to select between outdoor air or return air, whichever has lower enthalpy

### **Field Installed**

#### **Outdoor Air CFM Control**

- Maintains constant outdoor air volume levels on the supply air fan and varying unit airflows
- References a velocity sensor located in the rooftop unit outdoor air section
- Prodigy® 2.0 unit controller changes the economizer position to help minimize the effect of supply fan speed changes on outdoor air volume levels
- Setpoint for outdoor air volume is established by field testing

**NOTE** - Not available with Demand Control Ventilation (CO<sub>2</sub> Sensor) or Building Pressure Control.

#### **Building Pressure Control**

- Maintains constant building pressure level
- Using differential pressure information between the outdoor air and the building air, the Prodigy 2.0 unit controller changes the economizer position to help maintain a constant building pressure

**NOTE** - Not available with Demand Control Ventilation (CO<sub>2</sub> Sensor).

#### **Horizontal Economizer Conversion Kit**

- Insulated panel covers the bottom return air opening on the unit base to convert downflow economizer to horizontal air flow

### **EXHAUST**

#### **Factory or Field Installed**

##### **Power Exhaust Fan**

- Installs internal to unit for downflow applications with economizer option
- Provides exhaust air pressure relief
- Interlocked to run when supply air blower is operating
- Fan runs when outdoor air dampers are 50% open (adjustable)
- Motor is overload protected
- Fan is 16 in. diameter
- Four fan blades
- 1/3 hp motor

**NOTE** - If Power Exhaust is field installed with a factory installed Economizer, the Economizer must be ordered with No Exhaust option. Barometric Relief Dampers must also be ordered separately for field installation.

**NOTE** - If Power Exhaust is factory installed with a factory installed Economizer, Barometric Relief Dampers must also be ordered separately for field installation.

## OPTIONS / ACCESSORIES

### OUTDOOR AIR

#### Factory or Field Installed

##### Outdoor Air Damper

- Downflow or Horizontal
- Linked mechanical dampers
- 0 to 25% (fixed) outdoor air adjustable
- Installs in unit
- Includes outdoor air hood
- Automatic model features fully modulating spring return damper motor with plug-in connection
- Manual model features parallel blade, gear-driven dampers with adjustable fixed position

### ROOF CURBS

#### Field Installed

- Nailer strip furnished (downflow only)
- Mates to unit
- US National Roofing Contractors Approved
- Shipped knocked down

#### Hybrid Roof Curbs, Downflow

- Roof curb can be assembled using interlocking tabs to fasten corners together; no tools required
- Curb can also be fastened together with furnished hardware
- Available in 8, 14, 18, and 24 inch heights
- See Options/Accessories table

#### Adjustable Pitch Curb

- Fully adjustable pitch curbs (3/4 in. per foot in any direction) provide a level platform for rooftop units allowing flexible installations on roofs with uneven or sloped angles
- Uses interlocking tabs to fasten corners together; no tools required
- Hardware is furnished to connect upper curb with lower curb
- Available in 14 inch height

#### Adaptor Curbs (not shown)

- Curbs are regionally sourced
- Dimensions vary based upon the source

**NOTE** - Contact your local sales representative for a detailed cut sheet with applicable dimensions.

### CEILING DIFFUSERS

#### Field Installed

##### Ceiling Diffusers

##### (Flush or Step-Down)

- White powder coat finish on diffuser face and grilles
- Insulated UL listed duct liner
- Diffuser box has collars for duct connection
- Step-down diffusers have double deflection blades
- Flush diffusers have fixed blades
- Provisions for suspending
- Internally sealed to prevent recirculation
- Removable return air grille
- Adapts to T-bar ceiling grids or plaster ceilings

#### Transitions (Supply and Return)

- Used with diffusers
- Installs in roof curb
- Galvanized steel construction
- Flanges furnished for duct connection to diffusers
- Fully insulated

## OPTIONAL CONVENTIONAL TEMPERATURE CONTROL SYSTEMS

### ComfortSense® 8500 Commercial 7-Day Programmable Thermostat

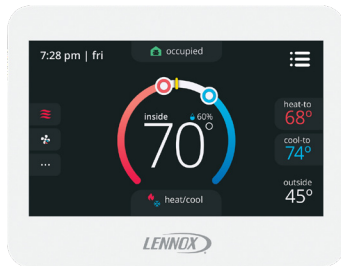

- Fully Communicating Sensor
- Full Color Touchscreen Interface
- Variable Speed System Control (On Compatible Units)
- Up To 4 Heat / 4 Cool
- Built-In Sensors For Temperature, Humidity And Optional CO<sub>2</sub>
- Remote Sensor Options For Occupancy, Temperature
- BACnet Capable Options
- 5-2 or 7-Day Scheduling
- Smooth Setback Recovery
- Heat/Cool Auto-Changeover
- Four-Wire Installation
- FDD, ASHRAE, IECC Compliant

### ComfortSense® 7500 Commercial 7-Day Programmable Thermostat



- Premium Universal Thermostat
- Full Color Touchscreen Interface
- Up To 4 Heat / 4 Cool
- Built-In Sensors For Temperature and Humidity
- Remote Sensors Options For Temperature, Discharge Air, Outdoor Air
- 5-2 or 7-Day Scheduling
- Smooth Setback Recovery
- Heat/Cool Auto-Changeover
- FDD, ASHRAE, IECC Compliant

### ComfortSense® 3000 Commercial 5-2 Day Programmable Thermostat

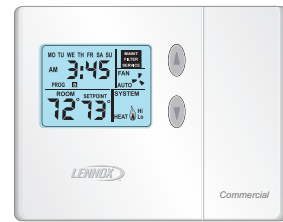

- Conventional Multi-Stage Thermostat
- Intuitive Display
- Push-Button Operation
- Up To 2 Heat / 2 Cool
- Built-In Temperature Sensor
- Remote Temperature Sensing
- Up to 5-2 Day Scheduling
- Smooth Setback Recovery
- Heat/Cool Auto-changeover

### Wired Room Sensor (LCS-5030)



- Simple Push-Button Override
- Variable Speed System Control (On Compatible Units)
- Up To 4 Heat / 4 Cool
- Built-In Temperature and Humidity Sensors
- AA Battery / 24VAC Powered
- SBUS Wired Operation
- Automatic Sensor Averaging
- Locking Hex Screw

## OPTIONAL CONVENTIONAL TEMPERATURE CONTROL SYSTEMS

Description	Catalog No.
<b>ComfortSense® 8500 Commercial 7 Day Programmable Thermostat</b>	
CS8500 7-Day Thermostat	No CO <sub>2</sub> Sensing <b>17G75</b>
	With CO <sub>2</sub> Sensing <b>17G76</b>
Sensors/Accessories	<sup>1</sup> Remote non-adjustable wall-mount 10k <b>47W37</b>
	<sup>1</sup> Remote non-adjustable wall-mount 11k <b>94L61</b>
<b>Sysbus Network Cable (Yellow) for ComfortSense 8500 and LCS-5030 Wired Room Sensor</b>	
Twisted pair 100% shielded communication cable, Red and Black	500 ft. box <b>27M19</b>
22 AWG, yellow jacket, rated at 75°C, 300V, Plenum rated	1000 ft. box <b>94L63</b>
Insulation - Low smoke PVC, NEC, CMP	2500 ft. roll <b>68M25</b>
<b>ComfortSense® 7500 Commercial 7-Day Programmable Thermostat</b>	
CS7500 7-Day Thermostat	<b>17G74</b>
Sensors/Accessories	<sup>2</sup> Remote non-adjustable wall-mount 20k <b>47W36</b>
	<sup>2</sup> Remote non-adjustable wall-mount 10k <b>47W37</b>
	Remote non-adjustable discharge air (duct mount) <b>19L22</b>
	Outdoor temperature sensor <b>X2658</b>
<b>ComfortSense® 3000 Commercial 5-2 Day Programmable Thermostat</b>	
CS3000 5-2 Day Thermostat	<b>11Y05</b>
Sensors/Accessories	Remote non-adjustable wall mount 10k averaging <b>47W37</b>
	Thermostat wall mounting plate <b>X2659</b>
<b>ComfortSense® Non-Programmable Thermostat</b>	
CS3000 Non-Programmable Thermostat	<b>51M32</b>
<b>Universal Thermostat Guard with Lock (clear)</b>	
	Inside Dimensions (H x W) 5 7/8 x 8 3/8 in. <b>39P21</b>
<b>Wired Room Sensor</b>	
LCS-5030 Wired Room Sensor	<b>21L07</b>

<sup>1</sup> Up to nine of the same type remote temperature sensors can be connected in parallel.

<sup>2</sup> Remote wall-mount sensors can be applied in any of the following combinations:

One Sensor - (1) 47W36, Two Sensors - (2) 47W37, Three Sensors - (2) 47W36 and (1) 47W37

Four Sensors - (4) 47W36, Five Sensors - (3) 47W36 and (2) 47W37

## OPTIONS / ACCESSORIES

Item	Catalog Number	Unit				
		036	048	060	074	
<b>COOLING SYSTEM</b>						
Condensate Drain Trap	PVC	<b>22H54</b>	OX	OX	OX	OX
	Copper	<b>76W27</b>	OX	OX	OX	OX
Drain Pan Overflow Switch		<b>21Z07</b>	OX	OX	OX	OX
Service Valves		Factory	O	O	O	O
<b>BLOWER - SUPPLY AIR</b>						
Motors	Direct Drive - 0.50 hp	Factory	O			
	Direct Drive - 0.75 hp	Factory		O		
	Direct Drive - 1 hp	Factory			O	O
<b>CABINET</b>						
Combination Coil/Hail Guards		<b>13T03</b>	X	X	X	X
Corrosion Protection (indoor coil / outdoor coil)		Factory	O	O	O	O
<b>CONTROLS</b>						
Commercial Controls	CPC Einstein Integration	Factory	O	O	O	O
	Prodigy® Control System - BACnet® Module	<b>59W51</b>	OX	OX	OX	OX
	Prodigy® Control System - LonTalk® Module	<b>54W27</b>	OX	OX	OX	OX
	Novar® LSE	Factory	O	O	O	O
	L Connection® Building Automation System	---	X	X	X	X
Dirty Filter Switch		<b>53W66</b>	OX	OX	OX	OX
General Purpose Control Kit		<b>13J78</b>	X	X	X	X
Fresh Air Tempering		<b>21Z08</b>	OX	OX	OX	OX
Smoke Detector - Supply or Return (Power board and one sensor)		<b>21Z11</b>	OX	OX	OX	OX
Smoke Detector - Supply and Return (Power board and two sensors)		<b>21Z12</b>	OX	OX	OX	OX
<b>ELECTRICAL</b>						
Voltage 60 hz	208/230V - 3 phase	Factory	O	O	O	O
	460V - 3 phase	Factory	O	O	O	O
HACR Circuit Breakers		Factory	O	O	O	O
<sup>1</sup> Short-Circuit Current Rating (SCCR) of 100kA (includes Phase/Voltage Detection)						
Disconnect Switch (See Electrical / Electric Heat Tables for selection)	80 amp	<b>22A23</b>	OX	OX	OX	OX
	150 amp	<b>22A24</b>			OX	OX
GFI Service Outlets	15 amp non-powered, field-wired	<b>74M70</b>	OX	OX	OX	OX
Weatherproof Cover for GFI		<b>10C89</b>	X	X	X	X
<b>ELECTRIC HEAT</b>						
7.5 kW	208/230V-3ph	<b>21Z26</b>	OX	OX	OX	OX
	460V-3ph	<b>21Z27</b>	OX	OX	OX	OX
15 kW	208/230V-3ph	<b>21Z28</b>	OX	OX	OX	OX
	460V-3ph	<b>21Z29</b>	OX	OX	OX	OX
22.5 kW	208/230V-3ph	<b>21Z30</b>			OX	OX
	460V-3ph	<b>21Z31</b>			OX	OX
SCR (Silicon Controlled Rectifier) Electric Heat Control		Factory	O	O	O	O
Thermostat (required)		<b>Y9682</b>	X	X	X	X
Duct Sensor (required)		<b>Y9683</b>	X	X	X	X

<sup>1</sup> Disconnect Switch not available with higher SCCR option.

NOTE - Catalog numbers shown are for ordering field installed accessories.

OX = Configure To Order (Factory Installed) or Field Installed.

O = Configure To Order (Factory Installed).

X = Field Installed.

## OPTIONS / ACCESSORIES

Item	Catalog Number	Unit			
		036	048	060	074
<b>ECONOMIZER</b>					
<b>High Performance Economizer With Outdoor Air Hood (Sensible Control) (Approved for California Title 24 Building Standards / AMCA Class 1A Certified)</b>					
High Performance Economizer - Includes Barometric Relief Dampers and Exhaust Hood	<b>20H48</b>	OX	OX	OX	OX
<b>Economizer Accessories</b>					
Horizontal Economizer Conversion Kit	<b>17W45</b>	X	X	X	X
<b>Economizer Controls</b>					
Differential Enthalpy (Not for Title 24)	Order 2 <b>21Z09</b>	OX	OX	OX	OX
Sensible Control	Sensor is Furnished Factory	O	O	O	O
Single Enthalpy (Not for Title 24)	<b>21Z09</b>	OX	OX	OX	OX
Global Control	Sensor Field Provided Factory	O	O	O	O
Building Pressure Control	<b>13J77</b>	X	X	X	X
Outdoor Air CFM Control	<b>13J76</b>	X	X	X	X
<b>POWER EXHAUST FAN (DOWNFLOW ONLY)</b>					
Standard Static	208/230V-3ph <b>21Z13</b>	OX	OX	OX	OX
<i>NOTE - Factory installed Power Exhaust Fan requires "Barometric Relief Dampers for Power Exhaust Kit" for field installation. See below.</i>	460V-3ph <b>21Z14</b>	OX	OX	OX	OX
<b>BAROMETRIC RELIEF</b>					
<sup>1</sup> Barometric Relief Dampers for Power Exhaust Kit	<b>21Z21</b>	X	X	X	X
<sup>2</sup> Horizontal Barometric Relief Dampers With Exhaust Hood	<b>19F01</b>	X	X	X	X
<b>OUTDOOR AIR</b>					
<b>Outdoor Air Dampers With Outdoor Air Hood</b>					
Motorized	<b>15D17</b>	OX	OX	OX	OX
Manual	<b>15D18</b>	OX	OX	OX	OX

<sup>1</sup> Required when Economizer is factory installed with factory installed Power Exhaust Fan option.

<sup>2</sup> Required when Economizer is configured for horizontal airflow.

NOTE - Catalog numbers shown are for ordering field installed accessories.

OX = Configure To Order (Factory Installed) or Field Installed.

O = Configure To Order (Factory Installed).

X = Field Installed.

## OPTIONS / ACCESSORIES

Item	Catalog Number	Unit				
		036	048	060	074	
<b>INDOOR AIR QUALITY</b>						
<b>Air Filters</b>						
Healthy Climate® High Efficiency Air Filters Order 4 per unit	MERV 8 (20 x 20 x 2 in.)	<b>54W21</b>	OX	OX	OX	OX
	MERV 13 (20 x 20 x 2 in.)	<b>52W39</b>	OX	OX	OX	OX
Replaceable Media Filter With Metal Mesh Frame (includes non-pleated filter media)	20 x 20 x 2 in. (Order 4)	<b>44N60</b>	OX	OX	OX	OX
<b>Indoor Air Quality (CO<sub>2</sub>) Sensors</b>						
Sensor - Wall-mount, off-white plastic cover with LCD display		<b>77N39</b>	X	X	X	X
Sensor - Wall-mount, off-white plastic cover, no display		<b>87N53</b>	X	X	X	X
Sensor - Black plastic case with LCD display, rated for plenum mounting		<b>87N52</b>	X	X	X	X
Sensor - Wall-mount, black plastic case, no display, rated for plenum mounting		<b>87N54</b>	X	X	X	X
CO <sub>2</sub> Sensor Duct Mounting Kit - for downflow applications		<b>85L43</b>	X	X	X	X
Aspiration Box - for duct mounting non-plenum rated CO <sub>2</sub> sensors ( <b>87N53</b> or <b>77N39</b> )		<b>90N43</b>	X	X	X	X
<b>UVC Germicidal Lamps</b>						
<sup>1</sup> Healthy Climate® UVC Light Kit (110/230V-1ph)		<b>21A92</b>	X	X	X	X
Step-Down Transformers	460V primary, 230V secondary	<b>10H20</b>	X	X	X	X
	575V primary, 230V secondary	<b>10H21</b>	X	X	X	X
<b>ROOF CURBS</b>						
<b>Hybrid Roof Curbs, Downflow</b>						
8 in. height		<b>11F50</b>	X	X	X	X
14 in. height		<b>11F51</b>	X	X	X	X
18 in. height		<b>11F52</b>	X	X	X	X
24 in. height		<b>11F53</b>	X	X	X	X
<b>Adjustable Pitched Curb</b>						
14 in. height		<b>43W27</b>	X	X	X	X
<b>Transition Curb</b>						
Matches Emergence® 036-074 Units to existing L Series® Curbs		<b>20W06</b>	X	X	X	X
<b>CEILING DIFFUSERS</b>						
Step-Down - Order one	RTD11-95S	<b>13K61</b>	X	X	X	X
Flush - Order one	FD11-95S	<b>13K56</b>	X	X	X	X
Transitions (Supply and Return) - Order one	T1TRAN20N-1	<b>17W54</b>	X	X	X	X

<sup>1</sup> Lamps operate on 110-230V single-phase power supply. Step-down transformer may be ordered separately for 460V units. Alternately, 110V power supply may be used to directly power the UVC ballast(s).

NOTE - Catalog numbers shown are for ordering field installed accessories.

OX = Configure To Order (Factory Installed) or Field Installed.

O = Configure To Order (Factory Installed).

X = Field Installed.

## SPECIFICATIONS

General Data		Nominal Tonnage	3 Ton	4 Ton	5 Ton	6 Ton
Model Number			LCH036U4E	LCH048U4E	LCH060U4E	LCH074U4E
Efficiency Type			Ultra	Ultra	Ultra	Ultra
Blower Type			MSAV (Multi-Stage Air Volume) Direct Drive	MSAV (Multi-Stage Air Volume) Direct Drive	MSAV (Multi-Stage Air Volume) Direct Drive	MSAV (Multi-Stage Air Volume) Direct Drive
<b>Cooling Performance</b>	Gross Cooling Capacity - Btuh		35,300	48,500	59,500	72,000
	<sup>1</sup> Net Cooling Capacity - Btuh		34,500	47,000	58,000	70,000
	AHRI Rated Air Flow - cfm		1200	1550	1800	2050
	Total Unit Power - kW		2.3	3.4	4.5	5.8
	SEER (Btuh/Watt) - 208/230V-3ph		<sup>1</sup> 23.5	<sup>1</sup> 21.0	<sup>1</sup> 20.0	---
	SEER (Btuh/Watt) - 460V-3ph		<sup>1</sup> 22.5	<sup>1</sup> 20.2	<sup>1</sup> 19.5	---
	EER (Btuh/Watt) - 208/230V-3ph		<sup>1</sup> 15.0	<sup>1</sup> 14.0	<sup>1</sup> 13.0	<sup>2</sup> 12.0
	EER (Btuh/Watt) - 460V-3ph		<sup>1</sup> 14.5	<sup>1</sup> 13.7	<sup>1</sup> 12.5	<sup>2</sup> 12.0
	IEER (Btuh/Watt) - 208/230V-3ph		---	---	---	<sup>2</sup> 22.0
IEER (Btuh/Watt) - 460V-3ph		---	---	---	<sup>2</sup> 22.0	
<b>Refrigerant Charge</b>	Refrigerant Type		R-410A	R-410A	R-410A	R-410A
			17 lbs. 0 oz.	17 lbs. 0 oz.	16 lbs. 11 oz.	16 lbs. 11 oz.
<b>Electric Heat Available - page 25</b>			7.5 and 15 kW	7.5 and 15 kW	7.5, 15 and 22.5 kW	7.5, 15 and 22.5 kW
<b>Compressor Type (number)</b>			Variable Capacity Scroll (1)	Variable Capacity Scroll (1)	Variable Capacity Scroll (1)	Variable Capacity Scroll (1)
<b>Outdoor Coil</b>	Net face area (total) - sq. ft.		19.3	19.3	19.3	19.3
	Tube diameter - in.		3/8	3/8	3/8	3/8
	Number of rows		2	2	2	2
	Fins per inch		20	20	20	20
<b>Outdoor Coil Fan</b>	Motor - (No.) horsepower		(1) 1/3 (ECM)	(1) 1/3 (ECM)	(1) 1/3 (ECM)	(1) 1/3 (ECM)
	Motor rpm		550 - 850	600 - 900	700 - 950	700 - 1050
	Total Motor Input - watts		50 - 200	80 - 236	120 - 272	120 - 360
	Diameter - (No.) in.		(1) 24	(1) 24	(1) 24	(1) 24
	Number of blades		3	3	3	3
	Total air volume - cfm		2500 - 3850	2750 - 4100	3200 - 4300	3200 - 4700
<b>Indoor Coil</b>	Net face area (total) - sq. ft.		9.72	9.72	9.72	9.72
	Tube diameter - in.		3/8	3/8	3/8	3/8
	Number of rows		3	3	4	4
	Fins per inch		14	14	14	14
	Drain connection (Number) and size - in.		1 in. NPT coupling	1 in. NPT coupling	1 in. NPT coupling	1 in. NPT coupling
Expansion device type			Balance port TXV, removable head			
<sup>3</sup> <b>Indoor Blower</b>	Nominal motor HP		0.50 (ECM)	0.75 (ECM)	1 (ECM)	1 (ECM)
	Blower wheel nominal diameter x width - in.		(1) 10 x 10	(1) 10 x 10	(1) 11 x 10	(1) 11 x 10
<b>Filters</b>	Type of filter		Disposable			
	Number and size - in.		(4) 20 x 20 x 2	(4) 20 x 20 x 2	(4) 20 x 20 x 2	(4) 20 x 20 x 2
<b>Electrical characteristics</b>			208/230V or 460V - 60 hz -3 phase			

NOTE - Net capacity includes evaporator blower motor heat deduction. Gross capacity does not include evaporator blower motor heat deduction.

<sup>1,2</sup> AHRI Certified to AHRI Standard <sup>1</sup> 210/240 or <sup>2</sup> 340/360: 95°F outdoor air temperature and 80°F db/67°F wb entering evaporator air; minimum external duct static pressure.

<sup>2</sup> Using total air volume and system static pressure requirements determine from blower performance tables rpm and motor output required. Maximum usable output of motors furnished are shown. In Canada, nominal motor output is also maximum usable motor output. If motors of comparable output are used, be sure to keep within the service factor limitations outlined on the motor nameplate.



# RATINGS

NOTE – For Temperatures and Capacities not shown in tables, see bulletin – Cooling Unit Rating Table Correction Factor Data in Miscellaneous Engineering Data section.

## 3 TON - LCH036U4

Entering Wet Bulb Temperature	Total Air Volume	Outdoor Air Temperature Entering Outdoor Coil																	
		65°F						75°F						85°F					
		Total Cooling Cap.	Comp. Motor Input	Dis-charge Air Temp.	Sensible To Total Ratio (S/T)			Total Cooling Cap.	Comp. Motor Input	Dis-charge Air Temp.	Sensible To Total Ratio (S/T)			Total Cooling Cap.	Comp. Motor Input	Dis-charge Air Temp.	Sensible To Total Ratio (S/T)		
					Dry Bulb						Dry Bulb						Dry Bulb		
cfm	kBtuh	kW	°F	75°F	80°F	85°F	kBtuh	kW	°F	75°F	80°F	85°F	kBtuh	kW	°F	75°F	80°F	85°F	
63°F	550	---	---	---	---	---	---	---	---	---	---	---	---	---	---	---	---	---	---
	700	33.5	1.26	45.1	0.68	0.79	0.89	32.4	1.52	45.7	0.69	0.80	0.91	31.1	1.79	46.5	0.70	0.81	0.93
	850	35.5	1.22	47.9	0.71	0.83	0.95	34.3	1.48	48.4	0.72	0.85	0.97	32.8	1.76	49.3	0.73	0.86	0.99
	1000	37.1	1.19	50.0	0.74	0.88	1.00	35.7	1.46	50.9	0.75	0.89	1.00	34.2	1.74	51.7	0.77	0.91	1.00
	1200	38.7	1.16	52.9	0.78	0.94	1.00	37.2	1.44	53.6	0.80	0.96	1.00	35.7	1.71	54.4	0.81	0.98	1.00
	1400	40.0	1.14	55.2	0.82	0.99	1.00	38.5	1.41	55.9	0.84	1.00	1.00	37.1	1.69	56.6	0.86	1.00	1.00
67°F	550	32.7	1.27	45.5	0.54	0.63	0.71	31.7	1.53	46.4	0.54	0.63	0.72	30.5	1.80	47.3	0.54	0.64	0.73
	700	35.5	1.22	49.3	0.55	0.65	0.76	34.3	1.49	49.9	0.56	0.66	0.77	33.0	1.76	50.8	0.56	0.67	0.78
	850	37.7	1.19	51.9	0.57	0.68	0.80	36.3	1.46	52.7	0.57	0.69	0.81	34.7	1.73	53.3	0.58	0.71	0.83
	1000	39.2	1.15	54.0	0.59	0.72	0.84	37.7	1.43	54.6	0.59	0.73	0.86	36.2	1.71	55.2	0.60	0.74	0.88
	1200	40.8	1.13	56.2	0.61	0.76	0.90	39.2	1.40	56.7	0.62	0.77	0.92	37.7	1.68	57.1	0.63	0.79	0.94
	1400	42.2	1.09	57.7	0.64	0.80	0.96	40.5	1.37	58.1	0.65	0.82	0.98	38.7	1.66	58.7	0.66	0.84	1.00
71°F	550	34.7	1.24	50.0	0.43	0.51	0.60	33.5	1.50	50.9	0.43	0.52	0.60	32.3	1.77	51.7	0.43	0.52	0.61
	700	37.6	1.19	53.6	0.43	0.53	0.63	36.2	1.45	54.3	0.43	0.54	0.64	34.9	1.73	55.2	0.43	0.54	0.64
	850	39.8	1.14	56.2	0.44	0.55	0.66	38.3	1.42	56.8	0.44	0.56	0.67	36.7	1.69	57.6	0.44	0.56	0.68
	1000	41.4	1.11	58.3	0.44	0.57	0.69	39.9	1.39	58.7	0.45	0.58	0.70	38.2	1.67	59.2	0.45	0.59	0.72
	1200	43.2	1.08	60.0	0.46	0.60	0.74	41.5	1.35	60.6	0.46	0.61	0.75	39.8	1.64	61.1	0.46	0.62	0.77
	1400	44.5	1.05	61.6	0.47	0.63	0.78	42.8	1.33	62.0	0.47	0.64	0.80	40.9	1.62	62.4	0.48	0.65	0.82
Entering Wet Bulb Temperature	Total Air Volume	Outdoor Air Temperature Entering Outdoor Coil																	
		95°F						105°F						115°F					
		Total Cooling Cap.	Comp. Motor Input	Dis-charge Air Temp.	Sensible To Total Ratio (S/T)			Total Cooling Cap.	Comp. Motor Input	Dis-charge Air Temp.	Sensible To Total Ratio (S/T)			Total Cooling Cap.	Comp. Motor Input	Dis-charge Air Temp.	Sensible To Total Ratio (S/T)		
					Dry Bulb						Dry Bulb						Dry Bulb		
cfm	kBtuh	kW	°F	75°F	80°F	85°F	kBtuh	kW	°F	75°F	80°F	85°F	kBtuh	kW	°F	75°F	80°F	85°F	
63°F	550	---	---	---	---	---	---	---	---	---	---	---	---	25.1	2.75	45.9	0.69	0.81	0.92
	700	29.8	2.08	47.3	0.71	0.83	0.95	28.4	2.38	48.2	0.72	0.85	0.97	27.0	2.71	49.2	0.73	0.87	0.99
	850	31.4	2.05	50.1	0.74	0.88	1.00	29.9	2.36	51.1	0.76	0.90	1.00	28.3	2.70	52.2	0.78	0.93	1.00
	1000	32.6	2.03	52.6	0.78	0.94	1.00	31.1	2.35	53.5	0.80	0.96	1.00	29.4	2.67	54.5	0.82	0.99	1.00
	1200	34.0	2.00	55.3	0.83	1.00	1.00	32.6	2.31	56.0	0.86	1.00	1.00	31.0	2.65	57.0	0.88	1.00	1.00
	1400	35.6	1.98	57.4	0.88	1.00	1.00	34.1	2.29	58.1	0.91	1.00	1.00	32.4	2.62	59.0	0.94	1.00	1.00
67°F	550	29.3	2.08	48.1	0.55	0.65	0.74	28.0	2.39	49.2	0.55	0.65	0.76	26.7	2.71	50.2	0.56	0.66	0.77
	700	31.6	2.05	51.4	0.57	0.68	0.80	30.2	2.36	52.4	0.57	0.69	0.81	28.6	2.69	53.3	0.58	0.71	0.83
	850	33.3	2.02	53.9	0.59	0.72	0.85	31.7	2.34	54.7	0.60	0.73	0.87	30.0	2.67	55.5	0.61	0.75	0.89
	1000	34.6	2.00	55.8	0.61	0.76	0.90	32.8	2.31	56.4	0.62	0.78	0.93	31.2	2.65	57.1	0.63	0.80	0.95
	1200	35.8	1.97	57.7	0.64	0.81	0.97	34.1	2.28	58.2	0.66	0.83	0.99	32.3	2.62	59.0	0.67	0.86	1.00
	1400	36.9	1.95	59.4	0.67	0.86	1.00	35.0	2.27	60.1	0.69	0.89	1.00	33.1	2.60	60.9	0.71	0.91	1.00
71°F	550	31.0	2.06	52.5	0.43	0.53	0.62	29.6	2.36	53.6	0.43	0.53	0.63	28.2	2.69	54.5	0.43	0.54	0.64
	700	33.4	2.02	55.7	0.44	0.55	0.66	31.9	2.32	56.7	0.44	0.55	0.67	30.3	2.66	57.6	0.44	0.56	0.68
	850	35.1	1.99	58.3	0.44	0.57	0.69	33.5	2.30	58.8	0.45	0.58	0.71	31.8	2.63	59.6	0.45	0.59	0.73
	1000	36.5	1.97	59.9	0.45	0.60	0.73	34.8	2.27	60.5	0.46	0.61	0.75	33.0	2.61	61.1	0.47	0.62	0.77
	1200	38.0	1.94	61.5	0.47	0.63	0.79	36.1	2.26	62.2	0.47	0.64	0.81	34.2	2.59	62.7	0.48	0.66	0.83
	1400	38.9	1.91	63.1	0.47	0.66	0.84	37.0	2.23	63.4	0.49	0.68	0.86	35.0	2.57	64.0	0.49	0.70	0.89

# RATINGS

NOTE – For Temperatures and Capacities not shown in tables, see bulletin – Cooling Unit Rating Table Correction Factor Data in Miscellaneous Engineering Data section.

## 4 TON - LCH048U4

Entering Wet Bulb Temperature	Total Air Volume	Outdoor Air Temperature Entering Outdoor Coil																	
		65°F						75°F						85°F					
		Total Cooling Cap.	Comp. Motor Input	Dis-charge Air Temp.	Sensible To Total Ratio (S/T)			Total Cooling Cap.	Comp. Motor Input	Dis-charge Air Temp.	Sensible To Total Ratio (S/T)			Total Cooling Cap.	Comp. Motor Input	Dis-charge Air Temp.	Sensible To Total Ratio (S/T)		
					Dry Bulb						Dry Bulb						Dry Bulb		
cfm	kBtuh	kW	°F	75°F	80°F	85°F	kBtuh	kW	°F	75°F	80°F	85°F	kBtuh	kW	°F	75°F	80°F	85°F	
63°F	850	---	---	---	---	---	---	---	---	---	---	---	---	40.9	2.45	45.0	0.68	0.79	0.89
	1000	46.5	1.84	45.7	0.69	0.80	0.90	44.5	2.13	46.8	0.69	0.81	0.92	42.8	2.45	47.5	0.70	0.82	0.94
	1150	48.4	1.83	47.8	0.71	0.83	0.94	46.4	2.12	48.6	0.72	0.84	0.96	44.5	2.44	49.3	0.73	0.86	0.98
	1300	50.0	1.82	49.5	0.73	0.86	0.98	47.8	2.12	50.3	0.74	0.88	1.00	45.9	2.43	51.2	0.75	0.89	1.00
	1600	52.5	1.81	52.8	0.77	0.92	1.00	50.1	2.10	53.6	0.79	0.94	1.00	48.0	2.43	54.3	0.81	0.97	1.00
	1900	54.4	1.81	55.3	0.82	0.98	1.00	52.0	2.10	56.0	0.84	1.00	1.00	49.9	2.42	56.8	0.86	1.00	1.00
67°F	850	46.9	1.84	47.5	0.54	0.64	0.73	45.0	2.12	48.3	0.55	0.65	0.74	43.3	2.44	49.3	0.55	0.65	0.75
	1000	49.3	1.83	50.0	0.55	0.66	0.76	47.3	2.11	50.8	0.56	0.67	0.77	45.4	2.43	51.6	0.56	0.68	0.79
	1150	51.3	1.82	51.9	0.57	0.68	0.79	49.1	2.11	52.7	0.57	0.69	0.81	47.1	2.43	53.3	0.58	0.70	0.83
	1300	53.0	1.81	53.6	0.58	0.70	0.82	50.7	2.11	54.1	0.59	0.72	0.84	48.5	2.43	54.9	0.59	0.73	0.86
	1600	55.4	1.81	56.1	0.60	0.75	0.89	52.9	2.10	56.6	0.61	0.77	0.91	50.7	2.42	57.2	0.62	0.78	0.93
	1900	57.2	1.80	57.9	0.63	0.80	0.95	54.6	2.09	58.4	0.64	0.82	0.97	52.2	2.42	58.9	0.66	0.83	1.00
71°F	850	49.5	1.82	52.0	0.43	0.52	0.61	47.5	2.11	52.7	0.43	0.53	0.62	45.7	2.44	53.6	0.43	0.53	0.63
	1000	52.0	1.82	54.5	0.43	0.53	0.63	49.9	2.11	55.1	0.44	0.54	0.64	48.0	2.43	55.7	0.44	0.55	0.65
	1150	54.1	1.81	56.2	0.44	0.55	0.65	51.8	2.10	56.9	0.44	0.55	0.67	49.7	2.43	57.6	0.44	0.56	0.68
	1300	55.9	1.81	57.7	0.44	0.56	0.68	53.4	2.10	58.4	0.44	0.57	0.69	51.2	2.42	59.0	0.45	0.58	0.70
	1600	58.5	1.80	60.0	0.45	0.59	0.73	55.8	2.09	60.6	0.46	0.60	0.74	53.5	2.42	61.1	0.46	0.61	0.76
	1900	60.6	1.80	61.8	0.46	0.62	0.77	57.7	2.09	62.2	0.47	0.63	0.80	55.1	2.41	62.6	0.48	0.65	0.81
Entering Wet Bulb Temperature	Total Air Volume	Outdoor Air Temperature Entering Outdoor Coil																	
		95°F						105°F						115°F					
		Total Cooling Cap.	Comp. Motor Input	Dis-charge Air Temp.	Sensible To Total Ratio (S/T)			Total Cooling Cap.	Comp. Motor Input	Dis-charge Air Temp.	Sensible To Total Ratio (S/T)			Total Cooling Cap.	Comp. Motor Input	Dis-charge Air Temp.	Sensible To Total Ratio (S/T)		
					Dry Bulb						Dry Bulb						Dry Bulb		
cfm	kBtuh	kW	°F	75°F	80°F	85°F	kBtuh	kW	°F	75°F	80°F	85°F	kBtuh	kW	°F	75°F	80°F	85°F	
63°F	850	39.2	2.80	45.84	0.69	0.80	0.91	37.5	3.20	46.78	0.70	0.81	0.93	35.5	3.62	47.90	0.71	0.83	0.95
	1000	41.2	2.80	48.08	0.71	0.84	0.96	39.3	3.19	48.83	0.73	0.86	0.98	37.1	3.62	50.00	0.74	0.88	1.00
	1150	42.7	2.79	49.97	0.74	0.88	1.00	40.7	3.18	51.05	0.75	0.90	1.00	38.4	3.61	52.28	0.77	0.92	1.00
	1300	43.9	2.78	52.07	0.77	0.91	1.00	41.8	3.18	53.01	0.78	0.94	1.00	39.4	3.61	54.00	0.81	0.97	1.00
	1600	46.0	2.78	55.07	0.82	0.99	1.00	43.8	3.17	56.00	0.84	1.00	1.00	41.6	3.60	56.97	0.87	1.00	1.00
	1900	48.0	2.78	57.54	0.88	1.00	1.00	45.9	3.17	58.38	0.90	1.00	1.00	43.6	3.61	59.25	0.93	1.00	1.00
67°F	850	41.7	2.80	49.87	0.56	0.66	0.77	39.8	3.17	50.95	0.56	0.67	0.78	37.7	3.62	51.80	0.57	0.69	0.80
	1000	43.6	2.79	52.28	0.57	0.69	0.80	41.7	3.18	52.97	0.58	0.70	0.82	39.2	3.60	53.99	0.59	0.72	0.84
	1150	45.2	2.79	54.16	0.58	0.71	0.84	43.1	3.18	54.78	0.59	0.73	0.86	40.6	3.60	55.59	0.60	0.75	0.89
	1300	46.5	2.78	55.49	0.60	0.74	0.88	44.3	3.17	56.13	0.61	0.76	0.90	41.6	3.61	56.89	0.63	0.78	0.93
	1600	48.4	2.78	57.59	0.64	0.80	0.96	46.0	3.17	58.26	0.65	0.82	0.98	43.4	3.60	58.99	0.66	0.85	1.00
	1900	49.9	2.78	59.57	0.67	0.85	1.00	47.4	3.17	60.29	0.68	0.88	1.00	44.5	3.60	61.13	0.70	0.91	1.00
71°F	850	44.0	2.80	54.28	0.43	0.54	0.64	42.1	3.18	55.24	0.43	0.54	0.65	39.8	3.61	56.15	0.44	0.55	0.66
	1000	46.0	2.78	56.57	0.44	0.55	0.66	43.9	3.17	57.37	0.44	0.56	0.67	41.5	3.61	58.23	0.44	0.57	0.69
	1150	47.6	2.78	58.28	0.44	0.57	0.69	45.5	3.18	58.87	0.45	0.58	0.70	42.9	3.61	59.74	0.45	0.59	0.72
	1300	49.1	2.78	59.48	0.45	0.59	0.72	46.7	3.17	60.15	0.45	0.60	0.74	44.1	3.60	60.84	0.46	0.61	0.76
	1600	51.1	2.77	61.57	0.47	0.62	0.78	48.7	3.17	62.06	0.47	0.64	0.80	45.8	3.60	62.77	0.48	0.65	0.82
	1900	52.6	2.77	63.17	0.48	0.66	0.83	50.0	3.17	63.59	0.48	0.68	0.86	47.0	3.60	64.12	0.49	0.70	0.89

# RATINGS

NOTE – For Temperatures and Capacities not shown in tables, see bulletin – Cooling Unit Rating Table Correction Factor Data in Miscellaneous Engineering Data section.

## 5 TON - LCH060U4

Entering Wet Bulb Temperature	Total Air Volume	Outdoor Air Temperature Entering Outdoor Coil																	
		65°F						75°F						85°F					
		Total Cooling Cap.	Comp. Motor Input	Dis-charge Air Temp.	Sensible To Total Ratio (S/T)			Total Cooling Cap.	Comp. Motor Input	Dis-charge Air Temp.	Sensible To Total Ratio (S/T)			Total Cooling Cap.	Comp. Motor Input	Dis-charge Air Temp.	Sensible To Total Ratio (S/T)		
					Dry Bulb						Dry Bulb						Dry Bulb		
cfm	kBtuh	kW	°F	75°F	80°F	85°F	kBtuh	kW	°F	75°F	80°F	85°F	kBtuh	kW	°F	75°F	80°F	85°F	
63°F	950	---	---	---	---	---	---	---	---	---	---	---	---	---	---	---	---	---	---
	1150	56.1	2.48	45.2	0.67	0.77	0.87	54.7	2.79	45.8	0.67	0.78	0.88	52.8	3.18	46.4	0.68	0.79	0.90
	1300	58.3	2.48	46.9	0.68	0.80	0.91	56.5	2.80	47.7	0.69	0.80	0.92	54.7	3.19	48.1	0.70	0.82	0.94
	1550	61.0	2.48	49.5	0.71	0.84	0.96	59.0	2.80	50.0	0.72	0.85	0.98	57.0	3.20	50.6	0.73	0.87	0.99
	1800	63.1	2.47	51.4	0.75	0.89	1.00	61.2	2.80	52.1	0.76	0.90	1.00	59.0	3.21	52.8	0.77	0.92	1.00
	2300	66.3	2.47	55.3	0.81	0.97	1.00	64.1	2.80	55.8	0.82	0.99	1.00	61.9	3.21	56.5	0.83	1.00	1.00
67°F	950	56.4	2.48	45.9	0.53	0.62	0.71	54.8	2.79	46.4	0.54	0.63	0.72	53.1	3.19	47.4	0.54	0.63	0.72
	1150	59.9	2.48	49.1	0.54	0.64	0.74	58.1	2.80	49.6	0.55	0.65	0.75	56.1	3.19	50.6	0.55	0.65	0.75
	1300	61.9	2.48	51.0	0.55	0.66	0.76	60.1	2.80	51.5	0.55	0.67	0.78	58.0	3.20	52.2	0.56	0.67	0.79
	1550	64.6	2.47	53.4	0.57	0.69	0.81	62.5	2.80	54.1	0.57	0.69	0.82	60.4	3.21	54.5	0.58	0.70	0.84
	1800	66.9	2.46	55.2	0.59	0.72	0.85	64.8	2.80	55.7	0.59	0.73	0.87	62.3	3.21	56.3	0.60	0.74	0.88
	2300	70.2	2.45	57.8	0.63	0.79	0.94	67.8	2.80	58.3	0.63	0.80	0.96	65.3	3.22	58.8	0.63	0.81	0.98
71°F	950	59.7	2.48	50.3	0.43	0.51	0.59	58.1	2.80	50.9	0.43	0.51	0.60	56.3	3.20	51.6	0.43	0.52	0.60
	1150	63.3	2.47	53.3	0.43	0.52	0.62	61.5	2.80	53.9	0.43	0.53	0.62	59.5	3.21	54.6	0.43	0.53	0.63
	1300	65.6	2.47	55.2	0.43	0.53	0.63	63.6	2.80	55.7	0.43	0.54	0.64	61.5	3.21	56.3	0.43	0.54	0.65
	1550	68.5	2.46	57.6	0.43	0.55	0.66	66.4	2.80	58.1	0.44	0.55	0.67	64.0	3.22	58.7	0.44	0.55	0.68
	1800	70.9	2.45	59.1	0.44	0.58	0.70	68.6	2.80	59.7	0.44	0.58	0.71	66.0	3.22	60.1	0.45	0.59	0.72
	2300	74.2	2.44	61.7	0.46	0.62	0.76	71.7	2.79	62.0	0.47	0.62	0.78	68.9	3.22	62.6	0.46	0.63	0.79
Entering Wet Bulb Temperature	Total Air Volume	Outdoor Air Temperature Entering Outdoor Coil																	
		95°F						105°F						115°F					
		Total Cooling Cap.	Comp. Motor Input	Dis-charge Air Temp.	Sensible To Total Ratio (S/T)			Total Cooling Cap.	Comp. Motor Input	Dis-charge Air Temp.	Sensible To Total Ratio (S/T)			Total Cooling Cap.	Comp. Motor Input	Dis-charge Air Temp.	Sensible To Total Ratio (S/T)		
					Dry Bulb						Dry Bulb						Dry Bulb		
cfm	kBtuh	kW	°F	75°F	80°F	85°F	kBtuh	kW	°F	75°F	80°F	85°F	kBtuh	kW	°F	75°F	80°F	85°F	
63°F	950	---	---	---	---	---	---	45.9	4.10	45.3	0.67	0.78	0.88	43.7	4.60	46.4	0.68	0.79	0.90
	1150	50.7	3.63	47.2	0.69	0.80	0.92	48.5	4.12	48.0	0.70	0.82	0.94	46.1	4.62	48.9	0.71	0.84	0.96
	1300	52.4	3.65	48.9	0.71	0.83	0.96	50.1	4.13	49.7	0.72	0.85	0.98	47.5	4.63	50.7	0.73	0.87	1.00
	1550	54.6	3.66	51.4	0.74	0.89	1.00	52.1	4.15	52.3	0.76	0.91	1.00	49.4	4.66	53.2	0.78	0.94	1.00
	1800	56.3	3.66	53.7	0.78	0.94	1.00	53.9	4.16	54.5	0.80	0.96	1.00	51.0	4.67	55.4	0.82	0.99	1.00
	2300	59.5	3.68	57.2	0.86	1.00	1.00	57.1	4.18	58.0	0.87	1.00	1.00	54.4	4.70	58.8	0.91	1.00	1.00
67°F	950	51.1	3.64	48.3	0.54	0.64	0.73	49.0	4.13	49.3	0.55	0.64	0.74	46.6	4.63	50.5	0.55	0.65	0.75
	1150	54.0	3.65	51.4	0.55	0.66	0.76	51.6	4.15	52.0	0.56	0.67	0.79	49.0	4.65	53.2	0.56	0.68	0.80
	1300	55.7	3.66	52.8	0.57	0.69	0.80	53.2	4.15	53.7	0.57	0.69	0.82	50.5	4.67	54.5	0.58	0.71	0.84
	1550	57.9	3.67	55.1	0.59	0.72	0.85	55.3	4.17	55.7	0.60	0.74	0.87	52.4	4.68	56.3	0.61	0.76	0.90
	1800	59.7	3.68	56.7	0.61	0.76	0.91	57.0	4.18	57.2	0.62	0.78	0.93	53.9	4.69	58.1	0.62	0.79	0.96
	2300	62.5	3.69	59.1	0.66	0.83	1.00	59.3	4.19	59.9	0.66	0.86	1.00	56.2	4.71	60.7	0.68	0.88	1.00
71°F	950	54.1	3.65	52.6	0.43	0.52	0.61	51.9	4.15	53.4	0.43	0.53	0.62	49.5	4.66	54.4	0.43	0.53	0.63
	1150	57.2	3.66	55.4	0.43	0.53	0.64	54.7	4.16	56.2	0.43	0.54	0.65	52.0	4.68	57.0	0.44	0.55	0.66
	1300	59.1	3.68	57.0	0.43	0.55	0.66	56.4	4.18	57.8	0.44	0.55	0.67	53.5	4.69	58.7	0.44	0.56	0.68
	1550	61.4	3.69	59.1	0.45	0.57	0.69	58.6	4.19	59.8	0.45	0.58	0.70	55.6	4.70	60.3	0.45	0.60	0.73
	1800	63.3	3.69	60.6	0.46	0.60	0.73	60.3	4.20	61.2	0.46	0.61	0.75	57.0	4.72	61.9	0.46	0.62	0.77
	2300	66.0	3.70	63.0	0.47	0.64	0.81	62.8	4.21	63.3	0.48	0.67	0.83	59.4	4.74	64.0	0.48	0.67	0.86

# RATINGS

NOTE – For Temperatures and Capacities not shown in tables, see bulletin – Cooling Unit Rating Table Correction Factor Data in Miscellaneous Engineering Data section.

## 6 TON - LCH074U4

Entering Wet Bulb Temperature	Total Air Volume	Outdoor Air Temperature Entering Outdoor Coil																	
		65°F						75°F						85°F					
		Total Cooling Cap.	Comp. Motor Input	Dis-charge Air Temp.	Sensible To Total Ratio (S/T)			Total Cooling Cap.	Comp. Motor Input	Dis-charge Air Temp.	Sensible To Total Ratio (S/T)			Total Cooling Cap.	Comp. Motor Input	Dis-charge Air Temp.	Sensible To Total Ratio (S/T)		
					Dry Bulb						Dry Bulb						Dry Bulb		
cfm	kBtuh	kW	°F	75°F	80°F	85°F	kBtuh	kW	°F	75°F	80°F	85°F	kBtuh	kW	°F	75°F	80°F	85°F	
63°F	950	---	---	---	---	---	---	---	---	---	---	---	---	---	---	---	---	---	---
	1200	---	---	---	---	---	---	---	---	---	---	---	---	---	---	---	---	---	---
	1500	70.9	3.24	45.3	0.68	0.80	0.90	68.6	3.66	46.0	0.69	0.80	0.92	66.6	4.17	46.4	0.70	0.82	0.93
	1750	73.7	3.25	47.8	0.70	0.83	0.95	71.5	3.67	48.0	0.72	0.85	0.97	68.8	4.19	48.7	0.73	0.86	0.99
	2050	76.3	3.25	49.9	0.74	0.88	1.00	74.0	3.68	50.7	0.74	0.89	1.00	71.3	4.21	51.3	0.76	0.91	1.00
	2300	78.3	3.25	51.7	0.77	0.92	1.00	75.8	3.69	52.4	0.78	0.93	1.00	72.9	4.22	53.2	0.79	0.95	1.00
67°F	950	65.1	3.22	41.3	0.53	0.61	0.69	63.4	3.63	42.3	0.53	0.61	0.69	61.4	4.13	43.1	0.53	0.62	0.70
	1200	70.4	3.24	45.8	0.54	0.63	0.72	68.5	3.66	46.5	0.54	0.63	0.73	66.3	4.17	47.3	0.54	0.64	0.74
	1500	75.2	3.25	49.5	0.55	0.66	0.76	72.9	3.68	50.2	0.56	0.66	0.77	70.3	4.20	50.9	0.56	0.67	0.78
	1750	78.1	3.25	51.9	0.56	0.68	0.80	75.7	3.69	52.4	0.57	0.69	0.81	72.9	4.22	52.9	0.58	0.70	0.83
	2050	80.9	3.25	53.9	0.58	0.72	0.84	78.2	3.70	54.5	0.58	0.73	0.86	75.3	4.23	54.9	0.60	0.74	0.87
	2300	82.8	3.25	55.3	0.60	0.74	0.88	80.1	3.70	55.6	0.61	0.76	0.90	77.2	4.24	56.2	0.61	0.77	0.92
71°F	950	69.1	3.23	45.9	0.43	0.51	0.58	67.3	3.65	46.8	0.43	0.51	0.58	65.1	4.17	47.6	0.43	0.51	0.59
	1200	74.8	3.25	50.2	0.43	0.52	0.60	72.6	3.68	50.9	0.43	0.52	0.61	70.2	4.20	51.7	0.43	0.52	0.62
	1500	79.6	3.25	54.0	0.43	0.53	0.63	77.2	3.70	54.4	0.43	0.54	0.64	74.5	4.23	55.2	0.43	0.54	0.65
	1750	82.7	3.25	56.1	0.44	0.55	0.65	80.2	3.70	56.7	0.44	0.55	0.66	77.3	4.24	57.1	0.44	0.56	0.68
	2050	85.5	3.25	58.1	0.44	0.57	0.69	82.9	3.71	58.7	0.44	0.57	0.70	79.9	4.26	59.1	0.45	0.58	0.71
	2300	87.7	3.25	59.3	0.45	0.59	0.72	85.0	3.71	59.7	0.45	0.60	0.73	81.6	4.27	60.4	0.45	0.60	0.74
Entering Wet Bulb Temperature	Total Air Volume	Outdoor Air Temperature Entering Outdoor Coil																	
		95°F						105°F						115°F					
		Total Cooling Cap.	Comp. Motor Input	Dis-charge Air Temp.	Sensible To Total Ratio (S/T)			Total Cooling Cap.	Comp. Motor Input	Dis-charge Air Temp.	Sensible To Total Ratio (S/T)			Total Cooling Cap.	Comp. Motor Input	Dis-charge Air Temp.	Sensible To Total Ratio (S/T)		
					Dry Bulb						Dry Bulb						Dry Bulb		
cfm	kBtuh	kW	°F	75°F	80°F	85°F	kBtuh	kW	°F	75°F	80°F	85°F	kBtuh	kW	°F	75°F	80°F	85°F	
63°F	950	---	---	---	---	---	---	---	---	---	---	---	---	---	---	---	---	---	---
	1200	---	---	---	---	---	---	---	---	---	---	---	---	---	---	---	---	---	---
	1500	63.7	4.76	47.4	0.71	0.83	0.95	60.8	5.38	48.1	0.72	0.85	0.98	57.7	6.01	49.1	0.73	0.87	1.00
	1750	65.9	4.77	49.7	0.73	0.88	1.00	63.0	5.40	50.6	0.75	0.90	1.00	59.7	6.03	51.8	0.76	0.92	1.00
	2050	68.3	4.80	52.2	0.77	0.93	1.00	65.0	5.42	53.1	0.79	0.96	1.00	61.9	6.06	54.0	0.81	0.98	1.00
	2300	69.8	4.81	54.0	0.81	0.97	1.00	66.6	5.44	54.8	0.83	0.99	1.00	63.3	6.07	55.8	0.85	1.00	1.00
67°F	950	59.1	4.71	44.3	0.53	0.62	0.71	56.8	5.33	45.1	0.54	0.63	0.72	54.3	5.97	46.3	0.54	0.64	0.73
	1200	63.7	4.75	48.1	0.55	0.65	0.75	61.0	5.38	49.1	0.55	0.66	0.76	58.0	6.01	50.2	0.56	0.67	0.77
	1500	67.6	4.79	51.6	0.56	0.68	0.80	64.5	5.41	52.4	0.57	0.69	0.82	61.3	6.05	53.1	0.58	0.71	0.84
	1750	70.0	4.81	53.7	0.58	0.71	0.84	66.8	5.44	54.3	0.59	0.73	0.86	63.3	6.08	55.1	0.60	0.74	0.89
	2050	72.1	4.83	55.6	0.61	0.74	0.90	69.0	5.46	56.0	0.62	0.77	0.92	65.4	6.11	56.7	0.63	0.79	0.95
	2300	73.8	4.84	56.7	0.62	0.79	0.94	70.5	5.47	57.1	0.64	0.81	0.97	66.6	6.12	57.9	0.65	0.83	0.99
71°F	950	62.8	4.74	48.8	0.43	0.51	0.59	60.2	5.36	49.9	0.43	0.51	0.60	57.7	6.01	50.8	0.43	0.52	0.61
	1200	67.5	4.79	52.6	0.43	0.53	0.62	64.7	5.42	53.5	0.43	0.53	0.63	61.6	6.06	54.5	0.43	0.54	0.64
	1500	71.6	4.82	56.0	0.43	0.55	0.65	68.4	5.45	56.6	0.44	0.55	0.67	65.1	6.10	57.5	0.44	0.56	0.68
	1750	74.2	4.84	57.8	0.44	0.57	0.69	70.7	5.48	58.6	0.45	0.57	0.70	67.2	6.12	59.1	0.45	0.59	0.72
	2050	76.6	4.86	59.7	0.45	0.59	0.72	73.0	5.50	60.2	0.46	0.60	0.74	69.3	6.15	60.7	0.46	0.62	0.77
	2300	78.2	4.88	60.7	0.46	0.62	0.76	74.6	5.51	61.2	0.47	0.63	0.78	70.4	6.16	61.9	0.47	0.64	0.81

**DIRECT DRIVE - 3 TON**

**BLOWER DATA**

**036 DIRECT DRIVE BLOWER - BASE UNIT**

**BLOWER TABLE INCLUDES RESISTANCE FOR BASE UNIT ONLY WITH DRY INDOOR COIL AND AIR FILTERS IN PLACE.**

FOR ALL UNITS ADD:

- 1 - Any factory installed options air resistance (heat section, economizer, etc.).
- 2 - Any field installed accessories air resistance (duct resistance, diffuser, etc.).

See page 24 for blower motors and drives and wet coil and options/accessory air resistance data.

**DOWNFLOW**

External Static Press. in. w.g.	Percentage of Total Motor Torque																													
	10%			20%			30%			40%			50%			60%			70%			80%			90%			100%		
	Cfm	RPM	Watts	Cfm	RPM	Watts	Cfm	RPM	Watts	Cfm	RPM	Watts	Cfm	RPM	Watts	Cfm	RPM	Watts	Cfm	RPM	Watts	Cfm	RPM	Watts	Cfm	RPM	Watts	Cfm	RPM	Watts
0.1	459	29	380	698	47	414	903	76	475	1069	110	539	1224	153	598	1374	195	632	1500	248	677	1617	312	723	1729	375	763	1821	447	803
0.2	357	32	464	596	55	520	828	86	563	1023	120	597	1180	165	634	1331	210	685	1461	264	727	1590	325	757	1704	387	796	1796	460	835
0.3	255	36	554	521	61	596	772	94	607	977	130	654	1137	177	706	1302	220	720	1435	274	776	1550	344	808	1666	406	843	1772	473	866
0.4	166	39	637	445	67	669	716	102	694	916	143	728	1108	185	740	1258	235	772	1397	289	808	1523	356	841	1641	417	874	1735	492	911
0.5	---	---	---	369	72	739	661	111	759	869	153	782	1050	200	807	1214	249	822	1358	304	855	1483	372	889	1603	434	919	1710	504	940
0.6	---	---	---	---	---	---	---	---	---	823	162	834	1006	212	856	1171	262	872	1319	318	900	1456	383	920	1565	450	962	1674	521	983
0.7	---	---	---	---	---	---	---	---	---	762	175	901	963	223	903	1127	275	920	1280	331	944	1416	398	966	1540	460	991	1637	536	1024
0.8	---	---	---	---	---	---	---	---	---	716	184	950	905	237	964	1083	287	968	1241	344	986	1376	412	1011	1502	474	1032	1612	546	1050
0.9	---	---	---	---	---	---	---	---	---	670	193	997	862	247	1007	1040	299	1014	1202	356	1027	1336	425	1054	1464	488	1072	1576	560	1088
1.0	---	---	---	---	---	---	---	---	---	623	202	1043	818	257	1049	981	314	1074	1151	371	1079	1296	437	1095	1426	501	1110	1539	573	1125
1.1	---	---	---	---	---	---	---	---	---	---	---	---	---	---	938	325	1118	1112	1112	1112	1112	1256	447	1135	1388	513	1147	1490	589	1171
1.2	---	---	---	---	---	---	---	---	---	---	---	---	---	---	---	---	---	---	---	---	---	1215	457	1174	1344	526	1188	1453	600	1204

**HORIZONTAL**

External Static Press. in. w.g.	Percentage of Total Motor Torque																													
	10%			20%			30%			40%			50%			60%			70%			80%			90%			100%		
	Cfm	RPM	Watts	Cfm	RPM	Watts	Cfm	RPM	Watts	Cfm	RPM	Watts	Cfm	RPM	Watts	Cfm	RPM	Watts	Cfm	RPM	Watts	Cfm	RPM	Watts	Cfm	RPM	Watts	Cfm	RPM	Watts
0.1	432	29	395	674	49	443	882	79	511	1053	115	567	1211	156	617	1334	205	676	1463	260	725	1583	322	769	1692	391	813	1791	466	852
0.2	334	32	479	581	56	537	822	87	582	1021	122	609	1178	165	659	1308	215	712	1439	270	758	1560	333	801	1670	402	843	1771	477	877
0.3	217	36	578	517	61	603	763	96	651	953	137	696	1128	179	720	1265	230	768	1400	286	809	1522	350	850	1634	420	888	1737	494	920
0.4	149	39	636	436	68	684	703	105	719	918	145	738	1079	193	781	1237	239	805	1374	297	842	1498	361	881	1611	431	917	1714	505	947
0.5	---	---	---	372	73	749	644	114	786	867	155	799	1046	201	820	1194	254	858	1335	312	891	1460	377	927	1576	447	960	1680	521	987
0.6	---	---	---	---	---	---	---	---	---	816	166	858	997	214	879	1152	267	909	1296	326	938	1435	387	957	1552	457	987	1645	536	1026
0.7	---	---	---	---	---	---	---	---	---	765	176	915	948	227	936	1109	280	959	1257	339	983	1398	401	1000	1517	471	1026	1611	550	1063
0.8	---	---	---	---	---	---	---	---	---	714	185	970	915	235	974	1081	288	991	1231	348	1013	1360	415	1041	1482	484	1064	1588	558	1087
0.9	---	---	---	---	---	---	---	---	---	663	194	1022	866	247	1030	1024	304	1052	1179	364	1070	1322	427	1081	1434	500	1112	1542	575	1133
1.0	---	---	---	---	---	---	---	---	---	611	203	1073	816	259	1085	981	315	1096	1140	376	1112	1285	438	1118	1399	511	1146	1508	586	1165
1.1	---	---	---	---	---	---	---	---	---	---	---	---	---	---	939	325	1138	1138	1138	1138	1138	1235	452	1166	1364	521	1178	1474	596	1197
1.2	---	---	---	---	---	---	---	---	---	---	---	---	---	---	---	---	---	---	---	---	---	1198	461	1200	1323	532	1214	1439	606	1227

**DIRECT DRIVE - 4 TON**

**BLOWER DATA**

**048 DIRECT DRIVE BLOWER - BASE UNIT**

**BLOWER TABLE INCLUDES RESISTANCE FOR BASE UNIT ONLY WITH DRY INDOOR COIL AND AIR FILTERS IN PLACE.**

FOR ALL UNITS ADD:

- 1 - Any factory installed options air resistance (heat section, economizer, etc.).
- 2 - Any field installed accessories air resistance (duct resistance, diffuser, etc.).

See page 24 for blower motors and drives and wet coil and options/accessory air resistance data.

**DOWNFLOW**

External Static Press. in. w.g.	Percentage of Total Motor Torque																											
	10%		20%		30%		40%		50%		60%		70%		80%		90%		100%									
	Cfm	RPM	Cfm	RPM	Cfm	RPM	Cfm	RPM	Cfm	RPM	Cfm	RPM	Cfm	RPM	Cfm	RPM	Cfm	RPM	Cfm	RPM	Cfm	RPM						
0.1	682	46	894	79	499	1148	131	579	1366	192	651	1551	268	726	1725	348	781	840	2031	550	893	2165	669	950	2290	790	993	
0.2	583	52	836	87	562	1105	142	635	1329	204	697	1530	279	756	1695	368	827	883	2006	567	925	2149	683	972	2271	813	1023	
0.3	484	59	601	778	96	629	1062	152	688	1292	217	744	1500	294	800	1675	380	856	1837	1981	585	958	2125	704	1005	2252	834	1051
0.4	410	64	666	720	105	697	1019	162	739	1255	231	792	1469	309	841	1645	397	898	1808	1956	603	992	2100	723	1036	2233	851	1076
0.5	---	---	---	662	114	764	961	176	805	1218	244	840	1428	327	895	1615	414	937	1780	1931	622	1025	2076	741	1066	2205	874	1111
0.6	---	---	---	---	---	---	---	---	---	1182	257	887	1398	341	934	1585	429	974	1751	1906	641	1058	2052	758	1095	2186	886	1131
0.7	---	---	---	---	---	---	---	---	---	1145	270	933	1367	354	972	1555	443	1009	1722	1874	663	1098	2028	774	1122	2148	903	1167
0.8	---	---	---	---	---	---	---	---	---	1096	287	992	1326	372	1021	1515	462	1056	1693	1850	679	1129	1996	792	1157	2111	913	1196
0.9	---	---	---	---	---	---	---	---	---	1047	302	1047	1296	385	1058	1485	476	1090	1664	1824	693	1157	1963	807	1188	2073	916	1219
1.0	---	---	---	---	---	---	---	---	---	1010	312	1085	1255	403	1107	1455	491	1125	1635	1787	710	1195	1931	818	1216	2036	912	1236
1.1	---	---	---	---	---	---	---	---	---	---	---	---	---	---	1425	505	1160	1606	1762	1762	717	1216	1883	828	1250	1960	890	1260
1.2	---	---	---	---	---	---	---	---	---	---	---	---	---	---	---	---	---	---	1687	1687	715	1254	1834	827	1275	1848	834	1274

**HORIZONTAL**

External Static Press. in. w.g.	Percentage of Total Motor Torque																											
	10%		20%		30%		40%		50%		60%		70%		80%		90%		100%									
	Cfm	RPM	Cfm	RPM	Cfm	RPM	Cfm	RPM	Cfm	RPM	Cfm	RPM	Cfm	RPM	Cfm	RPM	Cfm	RPM	Cfm	RPM	Cfm	RPM	Cfm	RPM	Cfm	RPM		
0.1	641	46	875	82	522	1127	137	614	1334	202	691	1524	280	762	1694	367	827	881	1997	581	955	2119	699	1010	2241	830	1058	
0.2	568	50	831	90	582	1097	144	650	1310	211	723	1504	290	793	1671	379	859	921	1977	600	986	2106	715	1032	2227	846	1080	
0.3	483	56	584	778	98	647	1050	155	706	1269	225	777	1470	308	844	1642	396	900	1799	1953	621	1022	2079	743	1072	2199	873	1118
0.4	398	62	661	724	106	707	1004	167	764	1228	240	831	1436	325	891	1612	413	941	1777	1930	640	1055	2062	758	1096	2181	888	1140
0.5	---	---	---	671	113	763	957	179	822	1201	250	867	1413	335	921	1588	427	973	1748	1906	657	1087	2036	777	1129	2153	904	1170
0.6	---	---	---	---	---	---	---	---	---	1161	265	919	1378	350	964	1552	447	1019	1718	1874	676	1124	2000	796	1166	2115	917	1202
0.7	---	---	---	---	---	---	---	---	---	1120	279	970	1344	365	1006	1529	459	1049	1696	1850	688	1150	1974	805	1189	2078	922	1228
0.8	---	---	---	---	---	---	---	---	---	1093	288	1003	1310	379	1047	1493	477	1091	1667	1818	700	1180	1930	812	1220	2040	919	1246
0.9	---	---	---	---	---	---	---	---	---	1052	302	1051	1275	393	1087	1469	488	1118	1644	1779	711	1213	1896	812	1239	1984	903	1265
1.0	---	---	---	---	---	---	---	---	---	1012	314	1096	1241	407	1128	1434	502	1155	1615	1747	715	1235	1843	802	1259	1910	865	1276
1.1	---	---	---	---	---	---	---	---	---	---	---	---	---	---	1386	516	1201	1571	1684	1684	713	1266	1738	760	1277	1760	775	1282
1.2	---	---	---	---	---	---	---	---	---	---	---	---	---	---	---	---	---	---	1620	1620	697	1282	1633	707	1283	1667	736	1296

**DIRECT DRIVE - 5 TON | 6 TON**

**BLOWER DATA**

**060/074 DIRECT DRIVE BLOWER - BASE UNIT**

**BLOWER TABLE INCLUDES RESISTANCE FOR BASE UNIT ONLY WITH DRY INDOOR COIL AND AIR FILTERS IN PLACE.**

FOR ALL UNITS ADD:

- 1 - Any factory installed options air resistance (heat section, economizer, etc.).
- 2 - Any field installed accessories air resistance (duct resistance, diffuser, etc.).

See page 24 for blower motors and drives and wet coil and options/accessory air resistance data.

**DOWNFLOW**

External Static Press. in. w.g.	Percentage of Total Motor Torque																																			
	10%			20%			30%			40%			50%			60%			70%			80%			90%			100%								
	Cfm	RPM	Watts	Cfm	RPM	Watts	Cfm	RPM	Watts	Cfm	RPM	Watts	Cfm	RPM	Watts	Cfm	RPM	Watts	Cfm	RPM	Watts	Cfm	RPM	Watts	Cfm	RPM	Watts	Cfm	RPM	Watts	Cfm	RPM	Watts	Cfm	RPM	Watts
0.1	743	58	428	992	100	492	1284	161	556	1526	231	607	1726	327	678	1890	427	737	2072	557	800	2220	686	848	2362	842	901	2478	996	938						
0.2	661	65	497	928	110	556	1231	175	610	1479	251	662	1685	348	726	1872	440	761	2052	574	827	2198	705	876	2344	860	925	2468	1016	969						
0.3	579	71	563	881	118	602	1179	188	663	1431	270	716	1658	362	757	1835	466	807	2024	597	863	2176	724	903	2322	881	952	2448	1035	993						
0.4	518	76	611	818	128	662	1126	202	716	1400	283	751	1618	383	802	1811	483	837	1995	619	898	2153	743	930	2301	900	978	2428	1053	1016						
0.5	455	81	654	754	138	719	1074	216	768	1352	301	801	1578	403	847	1775	507	881	1972	636	925	2120	769	968	2280	919	1002	2403	1074	1043						
0.6	400	86	695	695	152	760	1025	240	816	1305	319	850	1551	416	875	1738	529	922	1938	659	963	2098	785	992	2248	945	1037	2383	1090	1064						
0.7	350	91	736	646	166	801	1076	274	866	1273	330	882	1511	434	917	1714	544	948	1903	681	1000	2064	808	1026	2227	961	1059	2353	1113	1094						
0.8	300	96	777	596	180	842	1027	308	916	1226	347	928	1470	453	957	1678	564	986	1869	701	1033	2031	830	1058	2195	983	1090	2323	1133	1121						
0.9	250	101	818	546	194	878	1078	342	966	1178	363	972	1430	470	997	1641	583	1022	1835	720	1065	1998	849	1088	2163	1004	1119	2293	1151	1147						
1.0	200	106	859	496	208	910	1128	376	1000	1147	374	1000	1390	487	1034	1605	601	1057	1800	737	1094	1953	873	1125	2131	1022	1146	2263	1167	1170						
1.1	150	111	900	446	222	942	1178	410	1034	1156	387	1034	1556	507	1069	1755	623	1099	1755	756	1129	1920	888	1151	2089	1043	1177	2203	1193	1211						
1.2	100	116	941	396	236	974	1236	444	1068	1187	396	1068	1611	537	1107	1811	663	1147	1811	816	1175	1975	936	1181	2036	1063	1211	2169	1213	1227						

**HORIZONTAL**

External Static Press. in. w.g.	Percentage of Total Motor Torque																																					
	10%			20%			30%			40%			50%			60%			70%			80%			90%			100%										
	Cfm	RPM	Watts	Cfm	RPM	Watts	Cfm	RPM	Watts	Cfm	RPM	Watts	Cfm	RPM	Watts	Cfm	RPM	Watts	Cfm	RPM	Watts	Cfm	RPM	Watts	Cfm	RPM	Watts	Cfm	RPM	Watts	Cfm	RPM	Watts	Cfm	RPM	Watts	Cfm	RPM
0.1	695	49	431	1051	88	470	1280	157	562	1430	314	665	1615	420	753	1798	526	807	1957	656	873	2100	793	925	2228	947	979	2351	1107	1022								
0.2	610	55	495	973	96	543	1233	166	607	1382	332	715	1589	433	782	1762	547	847	1927	677	905	2079	808	947	2207	965	1002	2332	1126	1043								
0.3	525	61	560	914	104	612	1186	177	657	1347	345	752	1563	446	811	1738	561	873	1907	690	927	2047	830	979	2186	982	1024	2308	1148	1069								
0.4	461	66	611	856	115	695	1138	190	714	1312	358	788	1525	464	853	1702	581	911	1877	709	958	2026	844	999	2165	998	1046	2289	1164	1088								
0.5	400	71	652	802	122	749	1095	202	772	1277	370	823	1486	482	893	1678	593	936	1847	726	987	1995	864	1030	2144	1013	1067	2264	1182	1111								
0.6	350	76	693	752	136	790	1147	236	822	1242	382	857	1460	494	919	1642	612	972	1827	738	1007	1974	877	1050	2112	1035	1096	2239	1197	1133								
0.7	300	81	734	702	150	831	1208	270	876	1194	398	901	1421	510	957	1618	624	995	1787	760	1044	1943	896	1079	2091	1048	1115	2208	1213	1158								
0.8	250	86	775	652	164	872	1268	304	918	1148	413	943	1382	527	993	1582	641	1029	1757	775	1071	1912	914	1107	2059	1065	1142	2184	1223	1176								
0.9	200	91	816	602	178	913	1328	338	964	1112	424	974	1343	542	1028	1546	657	1061	1727	789	1096	1880	932	1135	2028	1081	1167	2147	1233	1200								
1.0	150	96	857	552	192	954	1388	372	1010	1069	438	1011	1305	557	1062	1510	673	1092	1687	807	1129	1849	948	1162	1996	1095	1191	2110	1238	1221								
1.1	100	101	900	502	214	995	1448	410	1034	1069	447	1034	1474	688	1122	1652	822	1156	1652	822	1156	1818	964	1188	1964	1107	1212	2060	1235	1243								
1.2	50	106	941	452	228	1036	1508	444	1068	1187	452	1068	1611	537	1107	1811	663	1147	1811	816	1175	1975	936	1181	2036	1063	1211	2169	1213	1227								

## BLOWER DATA

### FACTORY INSTALLED OPTIONS/FIELD INSTALLED ACCESSORY AIR RESISTANCE - in. w.g.

Air Volume cfm	Wet Indoor Coil		Electric Heat	Economizer	Filters	
	036, 048	060, 074			MERV 8	MERV 13
800	0.01	---	0.01	0.04	0.04	0.05
1000	0.02	0.02	0.03	0.04	0.04	0.07
1200	0.03	0.04	0.06	0.04	0.04	0.07
1400	0.04	0.05	0.09	0.04	0.04	0.07
1600	0.05	0.07	0.12	0.04	0.04	0.07
1800	0.06	0.08	0.15	0.05	0.04	0.07
2000	0.08	0.10	0.18	0.05	0.05	0.08
2200	---	0.11	0.18	0.05	0.05	0.08
2400	---	0.13	0.20	0.05	0.05	0.08

### POWER EXHAUST FAN PERFORMANCE

Return Air System Static Pressure in. w.g.	Air Volume Exhausted cfm
0.00	2000
0.05	1990
0.10	1924
0.15	1810
0.20	1664
0.25	1507
0.30	1350
0.35	1210

### CEILING DIFFUSERS AIR RESISTANCE (in. w.g.)

Air Volume - cfm	RTD11-95S Step-Down Diffuser			FD11-95S Flush Diffuser
	2 Ends Open	1 Side & 2 Ends Open	All Ends & Sides Open	
1800	0.13	0.11	0.09	0.09
2000	0.15	0.13	0.11	0.10
2200	0.18	0.15	0.12	0.12
2400	0.21	0.18	0.15	0.14
2600	0.24	0.21	0.18	0.17
2800	0.27	0.24	0.21	0.20
3000	0.32	0.29	0.25	0.25

### CEILING DIFFUSER AIR THROW DATA

Air Volume - cfm	<sup>1</sup> Effective Throw - ft.	
	RTD11-95S	FD11-95S
2600	24 - 29	19 - 24
2800	25 - 30	20 - 28
3000	27 - 33	21 - 29

<sup>1</sup> Effective throw based on terminal velocities of 75 ft. per minute.



**ELECTRICAL / ELECTRIC HEAT DATA**
**3 TON**

Model No.		LCH036U4E	
<sup>1</sup> Voltage - 60hz		208/230V - 3 Ph	460V - 3 Ph
Compressor	Rated Load Amps	9.1	5.1
Outdoor Fan Motor	Full Load Amps	4.1	2.1
Power Exhaust (1) 0.33 HP	Full Load Amps	2.4	1.3
Service Outlet 115V GFI (amps)		15	15
Indoor Blower Motor	Horsepower	0.5	0.5
	Full Load Amps	4.3	2.2
<sup>2</sup> Maximum Overcurrent Protection	Unit Only	25	15
	With (1) 0.33 HP Power Exhaust	30	15
<sup>3</sup> Minimum Circuit Ampacity	Unit Only	20	11
	With (1) 0.33 HP Power Exhaust	23	12

**ELECTRIC HEAT DATA**

Electric Heat Voltage			208V	240V	480V
<sup>2</sup> Maximum Overcurrent Protection	Unit+	7.5 kW	30	30	15
	Electric Heat	15 kW	<sup>4</sup> 45	60	30
<sup>3</sup> Minimum Circuit Ampacity	Unit+	7.5 kW	25	28	15
	Electric Heat	15 kW	45	51	26
<sup>2</sup> Maximum Overcurrent Protection	Unit+	7.5 kW	35	35	20
	Electric Heat and (1) 0.33 HP Power Exhaust	15 kW	<sup>4</sup> 50	60	30
<sup>3</sup> Minimum Circuit Ampacity	Unit+	7.5 kW	28	31	16
	Electric Heat and (1) 0.33 HP Power Exhaust	15 kW	48	54	27

**ELECTRICAL ACCESSORIES**

Disconnect	7.5 kW	22A23	22A23	22A23
	15 kW	22A23	22A23	22A23

NOTE - All units have a minimum Short Circuit Current Rating (SCCR) of 5000 amps.

<sup>1</sup> Extremes of operating range are plus and minus 10% of line voltage.

<sup>2</sup> HACR type breaker or fuse.

<sup>3</sup> Refer to National or Canadian Electrical Code manual to determine wire, fuse and disconnect size requirements.

<sup>4</sup> Factory installed circuit breaker not available.

**ELECTRICAL / ELECTRIC HEAT DATA**

**4 TON**

Model No.		LCH048U4E	
<sup>1</sup> Voltage - 60hz		208/230V - 3 Ph	460V - 3 Ph
Compressor	Rated Load Amps	13.8	6.5
Outdoor Fan Motor	Full Load Amps	4.1	2.1
Power Exhaust (1) 0.33 HP	Full Load Amps	2.4	1.3
Service Outlet 115V GFI (amps)		15	15
Indoor Blower Motor	Horsepower	0.75	0.75
	Full Load Amps	6.1	3.1
<sup>2</sup> Maximum Overcurrent Protection	Unit Only	40	15
	With (1) 0.33 HP Power Exhaust	40	20
<sup>3</sup> Minimum Circuit Ampacity	Unit Only	28	14
	With (1) 0.33 HP Power Exhaust	30	15

**ELECTRIC HEAT DATA**

Electric Heat Voltage			208V	240V	480V
<sup>2</sup> Maximum Overcurrent Protection	Unit+ 7.5 kW		40	40	20
	Electric Heat 15 kW		<sup>4</sup> 50	60	30
<sup>3</sup> Minimum Circuit Ampacity	Unit+ 7.5 kW		28	31	16
	Electric Heat 15 kW		47	53	27
<sup>2</sup> Maximum Overcurrent Protection	Unit+ 7.5 kW		40	40	20
	Electric Heat and (1) 0.33 HP Power Exhaust 15 kW		<sup>4</sup> 50	60	30
<sup>3</sup> Minimum Circuit Ampacity	Unit+ 7.5 kW		31	34	17
	Electric Heat and (1) 0.33 HP Power Exhaust 15 kW		50	56	29

**ELECTRICAL ACCESSORIES**

Disconnect	7.5 kW	22A23	22A23	22A23
	15 kW	22A23	22A23	22A23

NOTE - All units have a minimum Short Circuit Current Rating (SCCR) of 5000 amps.

<sup>1</sup> Extremes of operating range are plus and minus 10% of line voltage.

<sup>2</sup> HACR type breaker or fuse.

<sup>3</sup> Refer to National or Canadian Electrical Code manual to determine wire, fuse and disconnect size requirements.

<sup>4</sup> Factory installed circuit breaker not available.

**ELECTRICAL / ELECTRIC HEAT DATA**

**5 TON**

Model No.		LCH060U4E	
<sup>1</sup> Voltage - 60hz		208/230V - 3 Ph	460V - 3 Ph
Compressor	Rated Load Amps	14.6	7
Outdoor Fan Motor	Full Load Amps	4.1	2.1
Power Exhaust (1) 0.33 HP	Full Load Amps	2.4	1.3
Service Outlet 115V GFI (amps)		15	15
Indoor Blower Motor	Horsepower	1	1
	Full Load Amps	7.4	3.7
<sup>2</sup> Maximum Overcurrent Protection	Unit Only	40	20
	With (1) 0.33 HP Power Exhaust	45	20
<sup>3</sup> Minimum Circuit Ampacity	Unit Only	30	15
	With (1) 0.33 HP Power Exhaust	33	16

**ELECTRIC HEAT DATA**

Electric Heat Voltage			208V	240V	480V
<sup>2</sup> Maximum Overcurrent Protection	Unit+	7.5 kW	45	45	20
	Electric Heat	15 kW	<sup>4</sup> 50	60	30
		22.5 kW	<sup>4</sup> 70	80	40
<sup>3</sup> Minimum Circuit Ampacity	Unit+	7.5 kW	33	33	16
	Electric Heat	15 kW	49	55	28
		22.5 kW	68	77	39
<sup>2</sup> Maximum Overcurrent Protection	Unit+	7.5 kW	50	50	20
	Electric Heat and (1) 0.33 HP Power Exhaust	15 kW	60	60	30
		22.5 kW	80	80	45
<sup>3</sup> Minimum Circuit Ampacity	Unit+	7.5 kW	35	35	18
	Electric Heat and (1) 0.33 HP Power Exhaust	15 kW	52	58	29
		22.5 kW	71	80	41

**ELECTRICAL ACCESSORIES**

Disconnect	7.5 kW	22A23	22A23	22A23
	15 kW	22A23	22A23	22A23
	22.5 kW	22A24	22A24	22A23

NOTE - All units have a minimum Short Circuit Current Rating (SCCR) of 5000 amps.

<sup>1</sup> Extremes of operating range are plus and minus 10% of line voltage.

<sup>2</sup> HACR type breaker or fuse.

<sup>3</sup> Refer to National or Canadian Electrical Code manual to determine wire, fuse and disconnect size requirements.

<sup>4</sup> Factory installed circuit breaker not available.

**ELECTRICAL / ELECTRIC HEAT DATA**
**6 TON**

Model No.		LCH074U4E	
<sup>1</sup> Voltage - 60hz		208/230V - 3 Ph	460V - 3 Ph
Compressor	Rated Load Amps	16.9	8.3
	Locked Rotor Amps	---	---
Outdoor Fan Motor	Full Load Amps	4.1	2.1
Power Exhaust (1) 0.33 HP	Full Load Amps	2.4	1.3
Service Outlet 115V GFI (amps)		15	16
Indoor Blower Motor	Horsepower	1	1
	Full Load Amps	7.4	3.7
<sup>2</sup> Maximum Overcurrent Protection	Unit Only	45	20
	With (1) 0.33 HP Power Exhaust	50	25
<sup>3</sup> Minimum Circuit Ampacity	Unit Only	33	17
	With (1) 0.33 HP Power Exhaust	36	18

**ELECTRIC HEAT DATA**

Electric Heat Voltage			208V	240V	480V
<sup>2</sup> Maximum Overcurrent Protection	Unit+	7.5 kW	45	45	20
	Electric Heat	15 kW	<sup>4</sup> 50	60	30
		22.5 kW	<sup>4</sup> 70	80	40
<sup>3</sup> Minimum Circuit Ampacity	Unit+	7.5 kW	33	33	16
	Electric Heat	15 kW	49	55	28
		22.5 kW	68	77	39
<sup>2</sup> Maximum Overcurrent Protection	Unit+	7.5 kW	50	50	20
	Electric Heat and (1) 0.33 HP Power Exhaust	15 kW	60	60	30
		22.5 kW	80	80	45
<sup>3</sup> Minimum Circuit Ampacity	Unit+	7.5 kW	35	35	18
	Electric Heat and (1) 0.33 HP Power Exhaust	15 kW	52	58	29
		22.5 kW	71	80	41

**ELECTRICAL ACCESSORIES**

Disconnect	7.5 kW	22A23	22A23	22A23
	15 kW	22A23	22A23	22A23
	22.5 kW	22A24	22A24	22A23

NOTE - All units have a minimum Short Circuit Current Rating (SCCR) of 5000 amps.

<sup>1</sup> Extremes of operating range are plus and minus 10% of line voltage.

<sup>2</sup> HACR type breaker or fuse.

<sup>3</sup> Refer to National or Canadian Electrical Code manual to determine wire, fuse and disconnect size requirements.

<sup>4</sup> Factory installed circuit breaker not available.

## ELECTRIC HEAT CAPACITIES

Input Voltage	7.5 kW			15 kW			22.5 kW		
	No of Stages	kW input	Btuh Output	No of Stages	kW input	Btuh Output	No of Stages	kW input	Btuh Output
208	1	5.6	19,200	1	11.2	38,200	1	16.9	57,700
220	1	6.3	21,500	1	12.6	43,000	1	18.9	64,500
230	1	6.9	23,500	1	13.8	47,000	1	20.7	70,700
240	1	7.5	25,600	1	15	51,200	1	22.5	76,800
440	1	6.3	21,500	1	12.6	43,000	1	18.9	64,500
460	1	6.9	23,500	1	13.8	47,000	1	20.7	70,700
480	1	7.5	25,600	1	15	51,200	1	22.5	76,800

## UNIT CLEARANCES

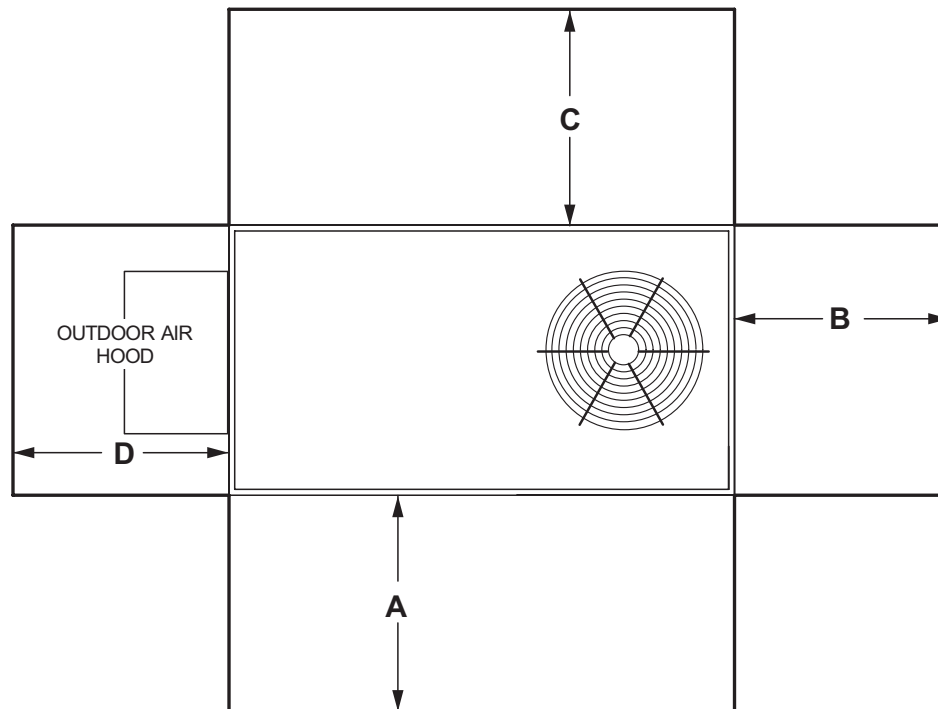

<sup>1</sup> Unit Clearance	A		B		C		D		Top Clearance
	in.	mm	in.	mm	in.	mm	in.	mm	
<b>Service Clearance</b>	36	914	36	914	36	934	36	914	Unobstructed
<b>Minimum Operation Clearance</b>	36	914	36	914	36	914	36	914	

NOTE - Entire perimeter of unit base requires support when elevated above the mounting surface.

<sup>1</sup> Service Clearance - Required for removal of serviceable parts.

Minimum Operation Clearance - Required clearance for proper unit operation.

## OUTDOOR SOUND DATA

Unit Model No.	Octave Band Sound Power Levels dBA, re 10 <sup>-12</sup> Watts Center Frequency - Hz							<sup>1,2</sup> Sound Rating Number dBA
	125	250	500	1000	2000	4000	8000	
036	60	65	69	68	63	58	51	73
048	64	67	73	71	66	59	52	76
060	66	69	74	74	68	62	55	78
074	67	72	76	76	70	64	58	80

NOTE - The octave sound power data does not include tonal corrections.

<sup>1</sup> Sound Rating Number according to AHRI Standard 270-2008. Sound Rating Number is the overall A-Weighted Sound Power Level, (LWA), dB (100 Hz to 10,000 Hz).

<sup>2</sup> Sound Rating Number according to AHRI Standard 370-2011. Sound Rating Number is the overall A-Weighted Sound Power Level, (LWA), dB (100 Hz to 10,000 Hz).

**WEIGHT DATA**

Model Number	Net		Shipping	
	lbs.	kg	lbs.	kg
036 Base Unit	674	306	716	325
036 Max. Unit	893	405	953	432
048 Base Unit	699	317	740	336
048 Max. Unit	918	416	978	443
060 Base Unit	723	328	765	347
060 Max. Unit	942	427	1002	454
074 Base Unit	723	328	765	347
074 Max. Unit	942	427	1002	454

**OPTIONS / ACCESSORIES**

	Shipping Weight		
	lbs.	kg	
<b>ECONOMIZER / OUTDOOR AIR / EXHAUST</b>			
<b>Economizer</b>			
Economizer, Includes Outdoor Air Hood and Barometric Relief Dampers with Hood	131	59	
<b>Outdoor Air Dampers</b>			
Motorized	40	18	
Manual	30	14	
<b>Power Exhaust</b>			
Standard Static	35	17	
<b>ELECTRIC HEAT</b>			
	7.5 kW	31	14
	15 kW	31	14
	22.5 kW	35	16
<b>PACKAGING</b>			
LTL Packaging (less than truck load)	60	27	
<b>ROOF CURBS</b>			
<b>Hybrid Roof Curbs, Downflow</b>			
8 in. height	C1CURB70A-1	50	23
14 in. height	C1CURB71A-1	70	32
18 in. height	C1CURB72A-1	80	36
24 in. height	C1CURB73A-1	100	45
<b>Adjustable Pitch Curb, Downflow</b>			
14 in. height		113	51
<b>CEILING DIFFUSERS</b>			
Step-Down	RTD11-95S	118	54
Flush	FD11-95S	118	54
Transitions	T1TRAN20N-1	21	10

# DIMENSIONS - UNIT

## CORNER WEIGHTS

Model No.	AA		BB		CC		DD		CENTER OF GRAVITY		EE		FF	
	lbs.	kg	lbs.	kg	lbs.	kg	lbs.	kg	in.	mm	in.	mm	in.	mm
	LCH036U Base Unit	127	58	162	73	210	95	165	75	38	953	21	521	
LCH036U Max. Unit	178	81	212	96	273	124	231	105	39	991	21	521		
LCH048U Base Unit	127	58	170	77	220	100	165	75	37	927	21	521		
LCH048U Max. Unit	178	81	221	100	286	130	230	104	38	965	21	521		
LCH060U Base Unit	131	59	174	79	225	102	169	77	37	927	21	521		
LCH060U Max. Unit	182	83	226	103	293	133	235	107	38	965	21	521		
LCH074U Base Unit	131	59	174	79	225	102	169	77	37	927	21	521		
LCH074U Max. Unit	182	83	226	103	293	133	235	107	38	965	21	521		

Base Unit - The unit with NO INTERNAL OPTIONS.

Max. Unit - The unit with ALL INTERNAL OPTIONS Installed. (Economizer, Standard Static Power Exhaust Fans, Controls, etc.). Does not include accessories external to unit or high static power exhaust.

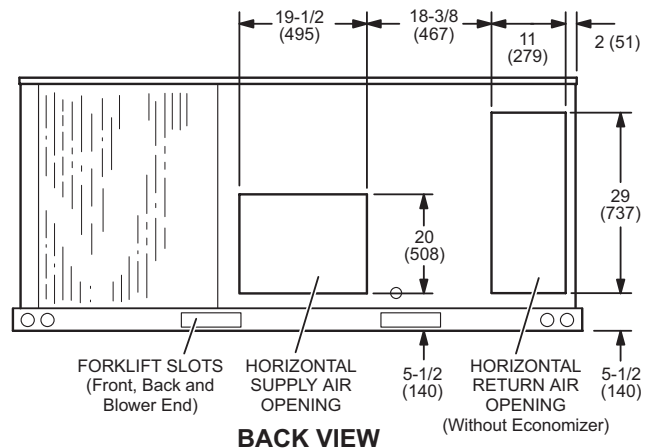
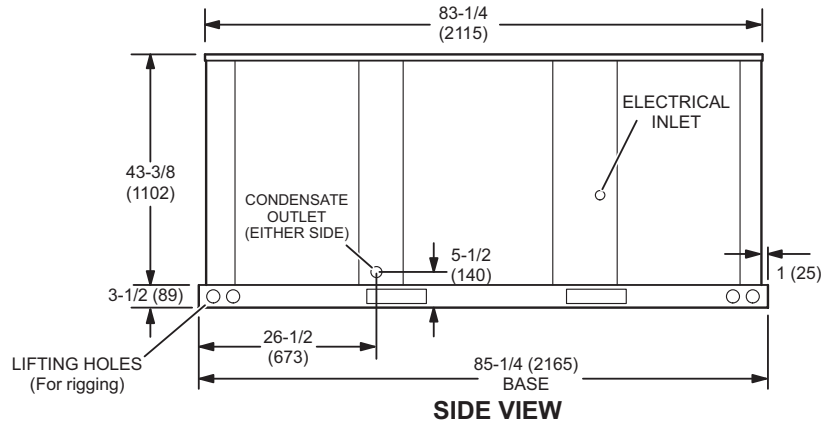
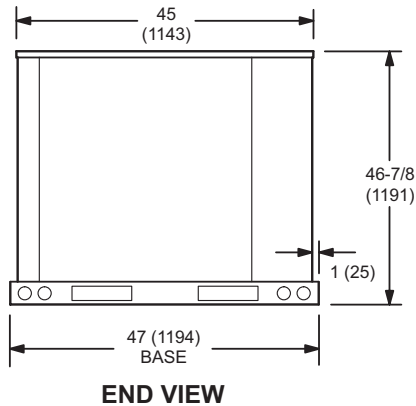
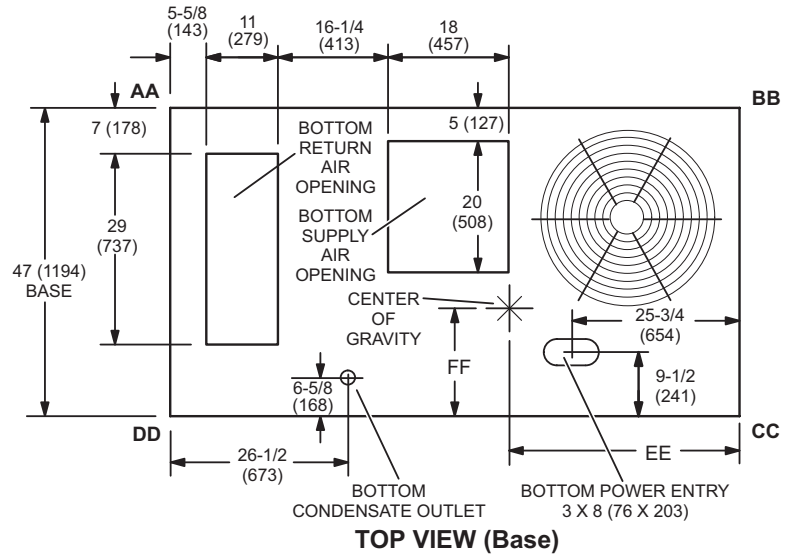

# DIMENSIONS - ACCESSORIES

## COMBINATION OUTDOOR AIR HOOD DETAIL FOR OPTIONAL ECONOMIZER AND BAROMETRIC RELIEF DAMPERS (Furnished With Economizer for Downflow Applications)

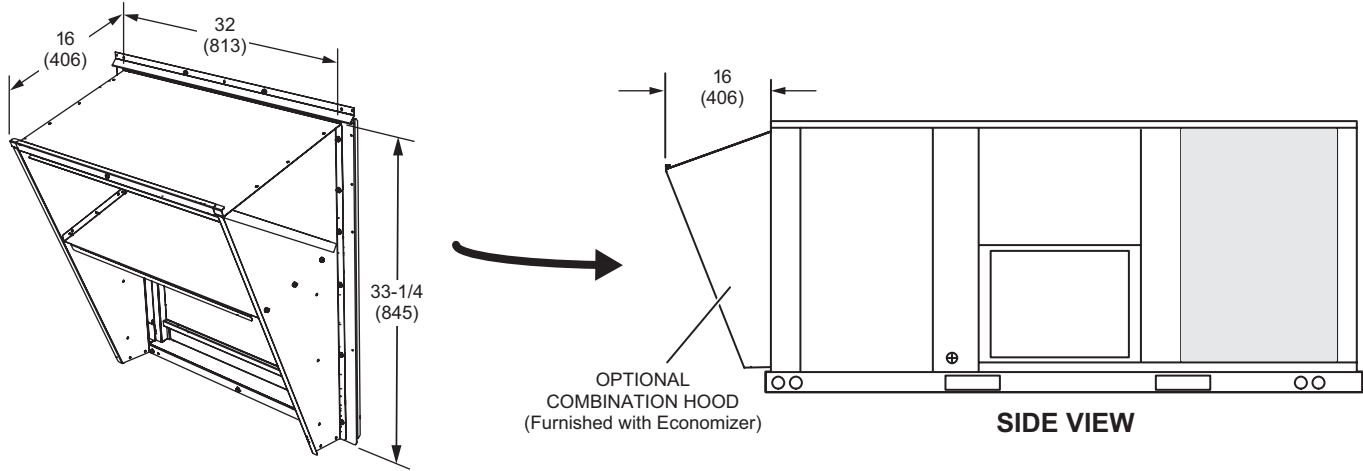

## OUTDOOR AIR DAMPER HOOD DETAIL (Downflow or Horizontal Applications)

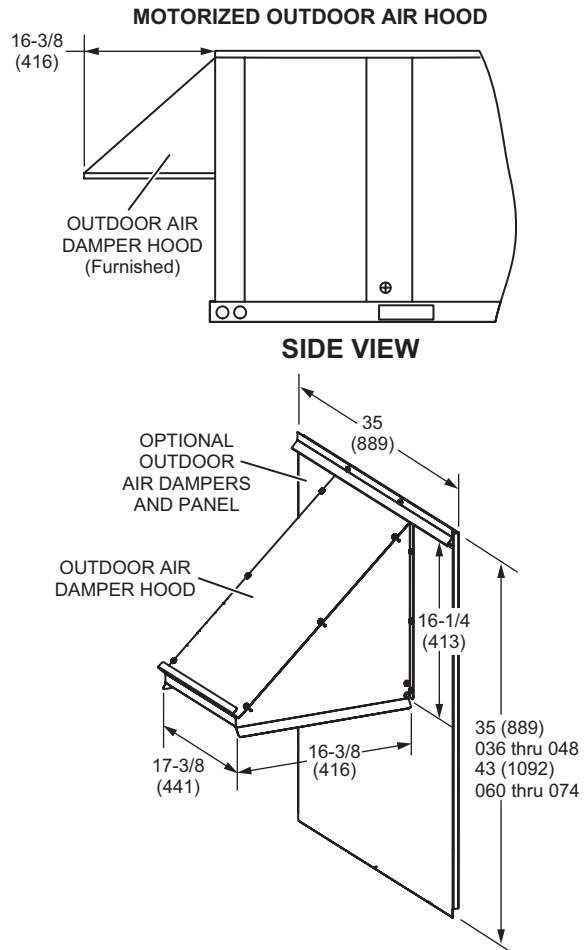
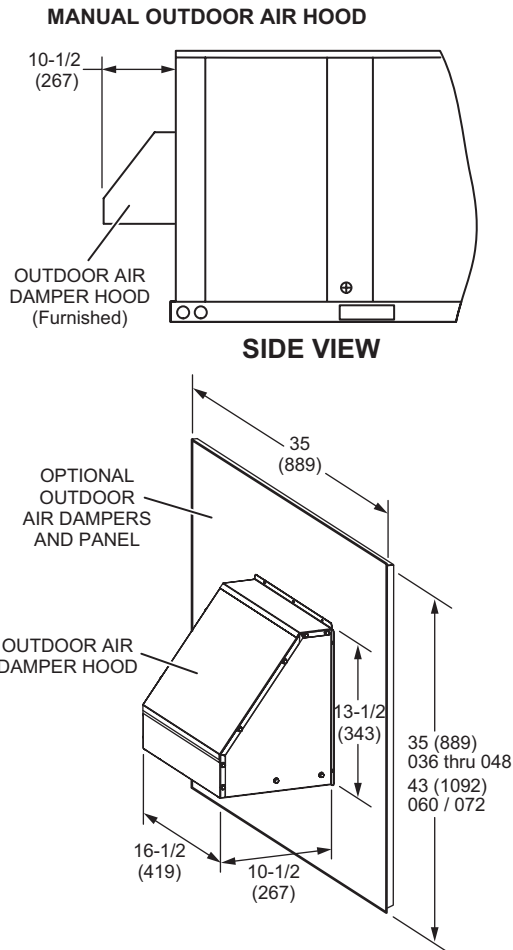



# DIMENSIONS - ACCESSORIES

## OUTDOOR AIR HOOD DETAIL WITH OPTIONAL ECONOMIZER AND OPTIONAL BAROMETRIC RELIEF DAMPERS WITH HOOD (Horizontal Application)

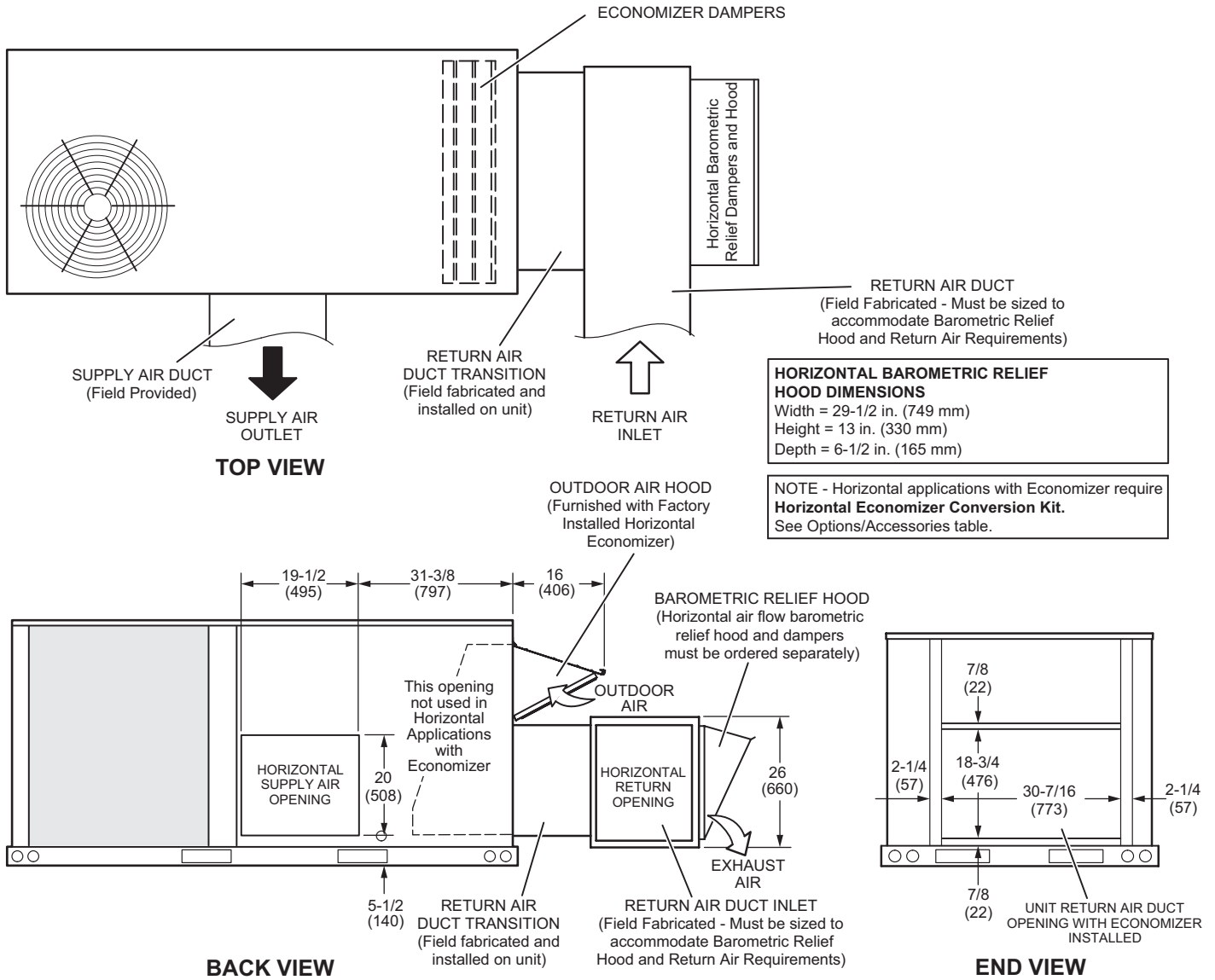

**NOTE - Return Air Duct and Transition must be supported**

# DIMENSIONS - ACCESSORIES

## HYBRID ROOF CURBS - DOUBLE DUCT OPENING

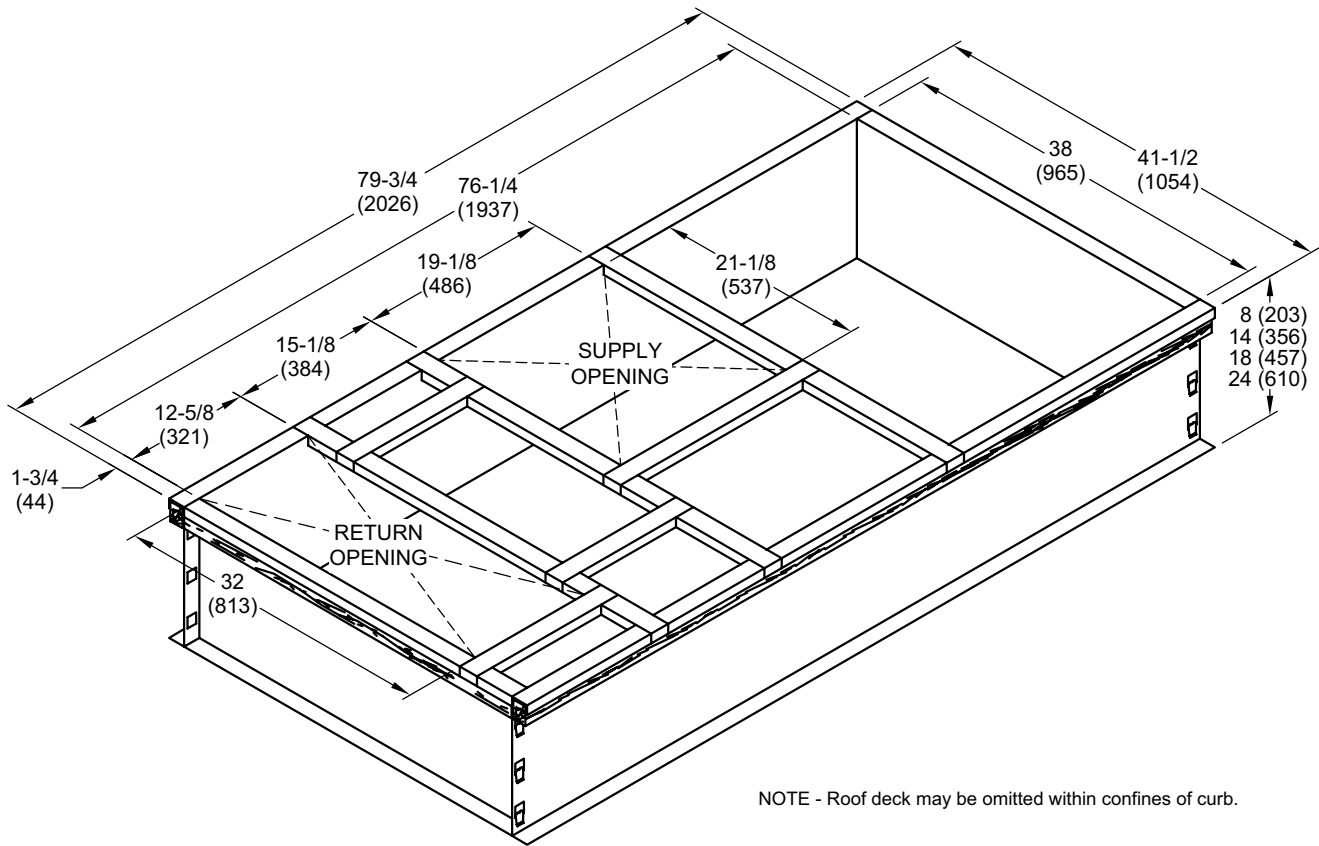

**TYPICAL FLASHING DETAIL FOR ROOF CURB**

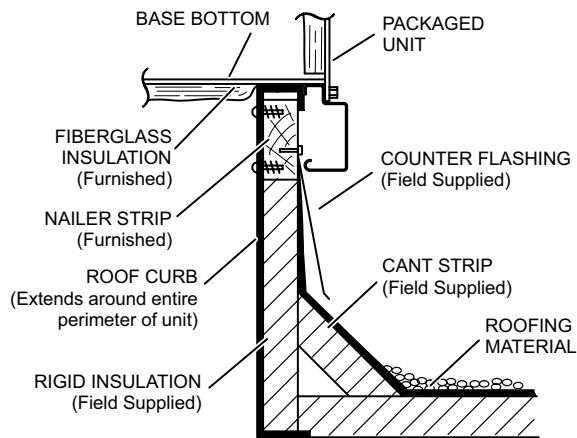

**DETAIL ROOF CURB**

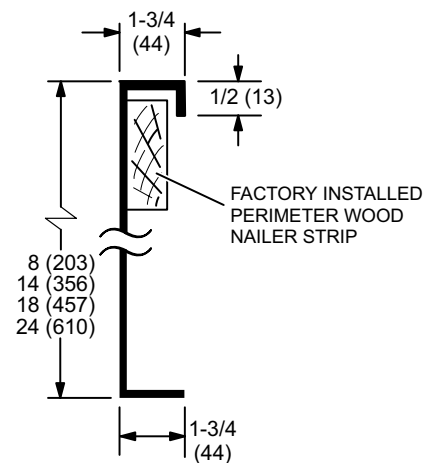

# DIMENSIONS - ACCESSORIES

## ADJUSTABLE PITCH CURBS - DOUBLE DUCT OPENING

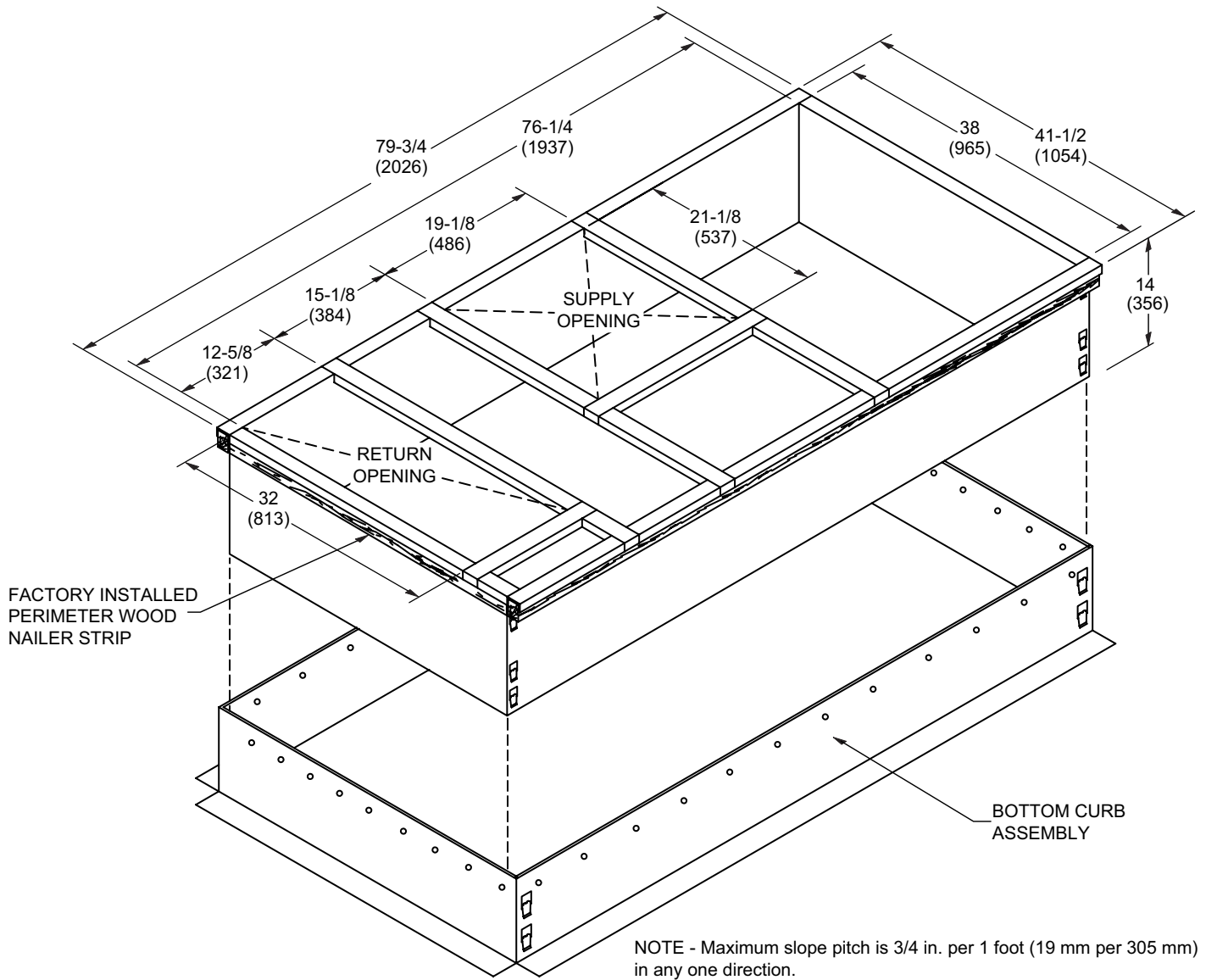

### TYPICAL FLASHING DETAIL FOR ROOF CURB

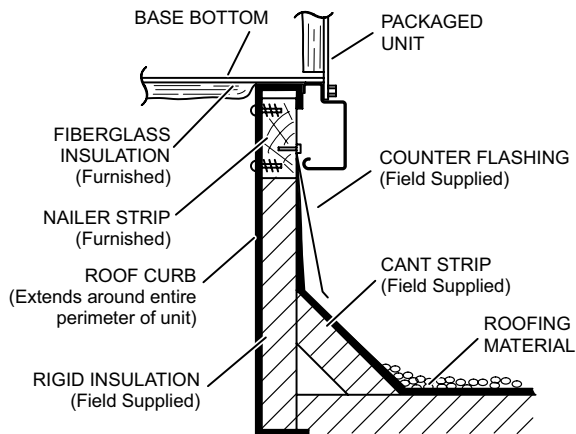

### DETAIL ROOF CURB

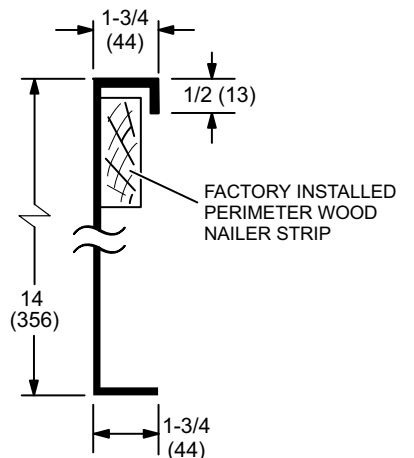

**DIMENSIONS - ACCESSORIES**

**TRANSITIONS**

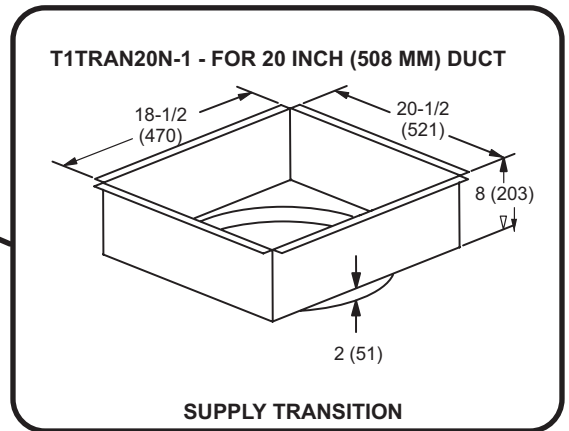
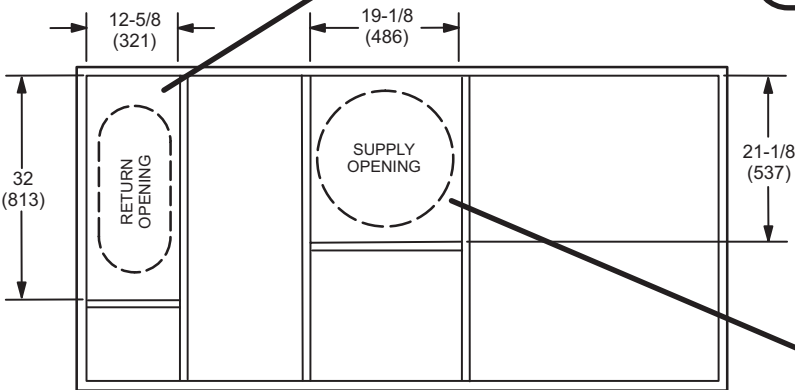
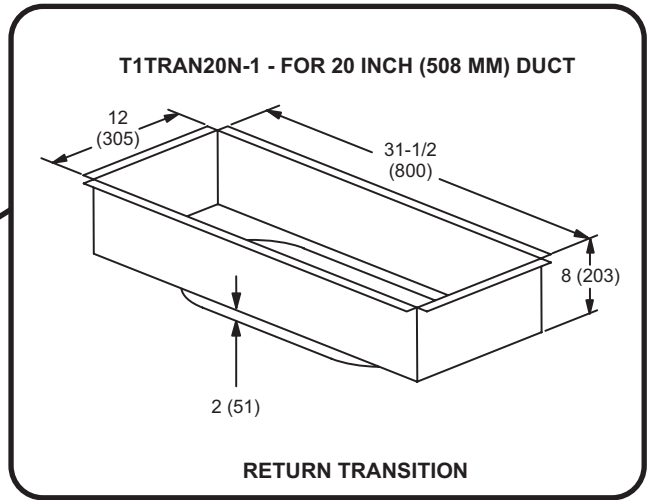

## DIMENSIONS - ACCESSORIES

### COMBINATION CEILING SUPPLY AND RETURN DIFFUSERS

#### STEP-DOWN CEILING DIFFUSER

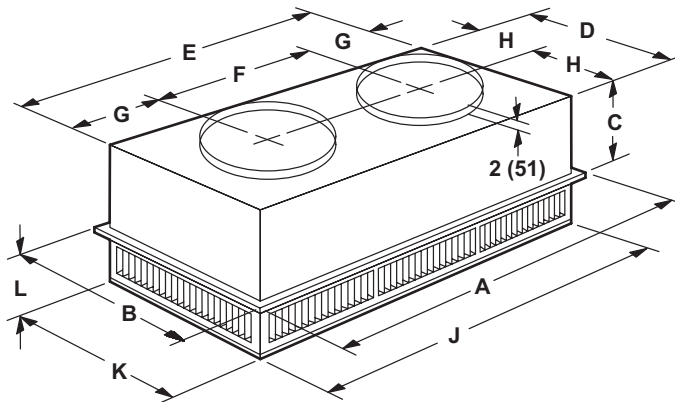

#### FLUSH CEILING DIFFUSER

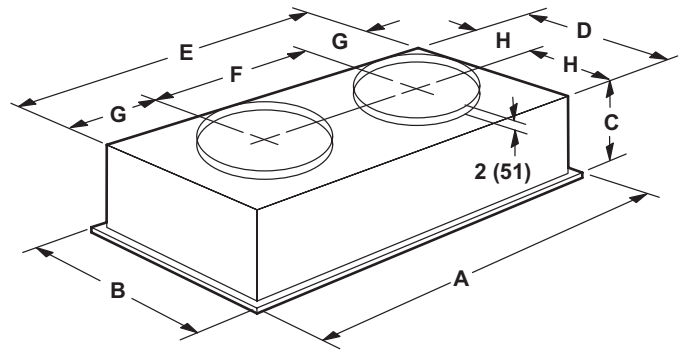

Model Number		RTD11-95S
A	in.	47-5/8
	mm	1159
B	in.	29-5/8
	mm	752
C	in.	14-3/8
	mm	365
D	in.	27-1/2
	mm	699
E	in.	45-1/2
	mm	1158
F	in.	22-1/2
	mm	572
G	in.	11-1/2
	mm	292
H	in.	13-3/4
	mm	349
J	in.	45-1/2
	mm	1156
K	in.	27-1/2
	mm	699
L	in.	8-1/8
	mm	206
Duct Size	in.	20 round
	mm	508 round

Model Number		FD11-95S
A	in.	47-5/8
	mm	1159
B	in.	29-5/8
	mm	752
C	in.	16-5/8
	mm	422
D	in.	27
	mm	686
E	in.	45
	mm	1143
F	in.	22-1/2
	mm	572
G	in.	11-1/4
	mm	286
H	in.	13-1/2
	mm	343
Duct Size	in.	20 round
	mm	508 round





## REVISIONS

Sections	Description of Change
Options/Accessories	<p>Added step-down transformers for UVC lights.</p> <p><b>Catalog numbers revised for:</b></p> <ul style="list-style-type: none"> <li>Blower Proving Switch</li> <li>Condensate Drain Trap</li> <li>Discharge Air Temperature Switch</li> <li>Disconnects</li> <li>Economizers</li> <li>Electric Heat</li> <li>Drain Pan Overflow Switch</li> <li>Gravity Exhaust Dampers</li> <li>Power Exhaust</li> <li>Single Enthalpy</li> <li>Smoke Detectors</li> </ul>

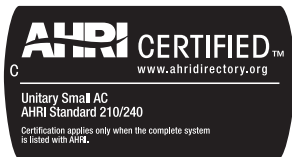

**Intertek**



Visit us at [www.lennox.com](http://www.lennox.com)

For the latest technical information, [www.lennoxcommercial.com](http://www.lennoxcommercial.com)

Contact us at 1-800-4-LENNOX

NOTE - Due to Lennox' ongoing commitment to quality, Specifications, Ratings and Dimensions subject to change without notice and without incurring liability. Improper installation, adjustment, alteration, service or maintenance can cause property damage or personal injury. Installation and service must be performed by a qualified installer and servicing agency.

©2021 Lennox Industries, Inc.