

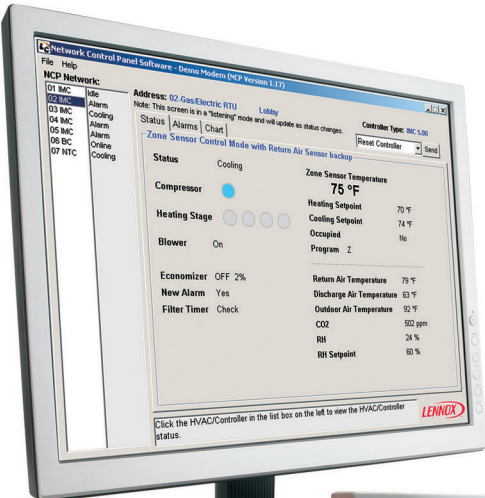

**L Connection® Network Control System
For Emergence® Rooftop Units**

PRODUCT SPECIFICATIONS

Bulletin No. 210594
September 2013
Supersedes May 2013



**Commercial Building Automation System
Advanced Single Point Control
For HVAC Systems And Building Operation**

FEATURES AND BENEFITS

CONTENTS	
Building Controller	27
Component Identification	2
Features And Benefits	2
Network Control Panel	13
Network Thermostat Controller	23
Prodigy® Unit Controller	15
System Architecture	4
System Components - Controllers	13
System Components - Miscellaneous Accessories	81
System Components - Network.	63
System Components - Ordering Information	91
System Components - Sensors	34
System Components - Software	72
System Overview	6
System Selection Flowcharts	7
Zone And Bypass Dampers.	78
Zone Link	30

COMPONENT IDENTIFICATION

C O SNSR 2 1 A E 1 L

Product Family
 C = Commercial Generic
 S = S-Class®
 T = T-Class™

Product Type
 0 = Building Automation / Automatic Temperature Control
 1 = Rooftops
 2 = Air Conditioners and Heat Pumps
 3 = Indoor Coils / Air Handlers
 4 = Furnaces
 5 = Unit Heaters / Duct Furnaces
 6 = General or Multi-Purpos

Basic Description
 SNSR = Sensor
 SNSJ = Sensor, Adjustable
 SNCT = Sensor / Controller
 SNDC = Sensor, Duct
 SNMT = Sensor, Multiple Function
 SNZN = Sensor, Zone (non-adjustable)
 STAT = Thermostat
 CTRL = DDC Controller or Interface
 SWCH = Switch
 SOFT = Software
 MISC = Miscellaneous (cables, wire, etc.)

Specific Description 1
 (example: CTRL)
 Controller Description, 1 Digit
 0 = Lennox Unit Controller
 1 = Lennox Network Controller
 2 = Lennox Building Controller
 3 = Third-Party Controller
 4 = Systems Integration Software
 (includes software drivers, configuration files, plug-ins, etc.)
 5 = Systems Integration hardware (gateway devices)

Voltage
 (Only shown if voltage dependant)
 Y = 208/230V-3 Phase
 G = 460V-3 Phase
 J = 575V-3 Phase
 L = Low Voltage (typically 24V)

Design Sequence
 1 = 1st Revision
 2 = 2nd Revision

Box Size
 1st character is smallest applicable size
 2nd character is largest applicable size
 If only certain sizes are applicable, letters can be placed out of sequence.
 (example: EAⁿ applicable to A and E box sizes only)
 A = A-Box Size
 B = B-Box Size and so on.

Specific Description 2
 (example: CTRL)
 Controller Description, 2nd Digit
 Specific to Catalog Number
 (example: CTRL00 = Sectra Bypass Control Kit 23M51)

FEATURES AND BENEFITS

Save money and time and provide a higher level of control by commanding a wide range of functions from a single location. The L Connection® Network makes it easy to manage HVAC, zoning and building operations from a single point of control, minimizing energy and maintenance costs. It was designed to enhance the functionality and performance of Lennox' premium rooftop units featuring the Prodigy® Unit Controller as well as other Lennox rooftop units and split systems. It is also fully compatible with electro-mechanically controlled third-party equipment. It's a cost-effective way to minimize your building's energy use and better manage facility operations.

L Connection Network not only improves building efficiency and comfort, it also helps to improve staff efficiency and productivity. Temperature setpoints can be adjusted quickly and intuitively at the Comfort Sensor. For more advanced control, facility managers can access and troubleshoot other Lennox and electro-mechanically controlled third-party equipment along with the building's lights and signage using local or remote interfaces.

The Comfort Sensor combines optional relative humidity (RH) and carbon dioxide (CO2) sensor options with a temperature sensor. Optional zone controller capabilities are also available when the Comfort Sensor is used in commercial zoning applications. This means less wiring and fewer sensors to install separately, and more flexible comfort control with an optional LCD interface which allows you to easily adjust the temperature. The adjustable range can be configured to control energy use while optimizing comfort and productivity. The Comfort Sensor also means easier service for the zone controller in the zone.

The Network Control Panel allows a facility manager advanced monitoring and control capabilities for troubleshooting and configuration adjustments, including scheduling, temperature set-point, humidity control and much more. Optional PC software provides access to a specific controller or the entire network locally, or remotely through a modem or the Internet (Internet access to Ethernet local area network (LAN) is required). This gives a facility manager or owner advanced control of their building from virtually anywhere and at any time. It also allows a servicing contractor to diagnose and troubleshoot remotely without sending someone to the site.

WARRANTY

Prodigy Unit Controller (furnished with Emergence® premium rooftop units) - Limited three years.

All other covered components - Limited one year.

SYSTEM ARCHITECTURE

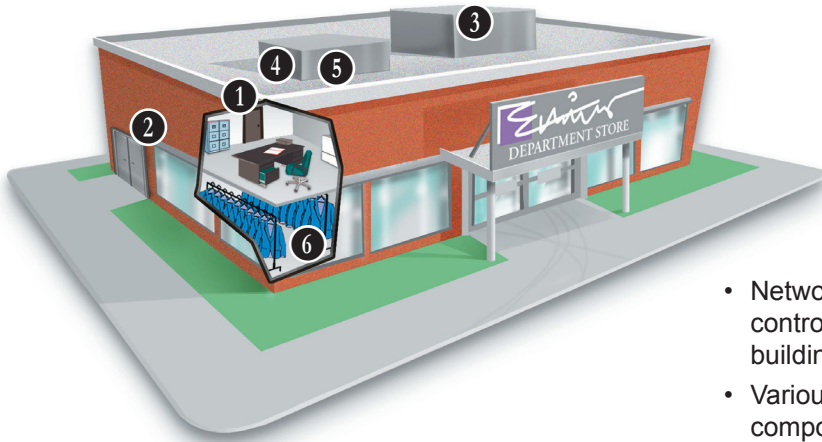

- Network Control Panel provides a central control point for HVAC systems and basic building operation.
- Various Controllers connect the network components together.
- Zone Controllers and various Sensors provide control at each zone.

NETWORK MANAGER PROVIDES A CENTRAL POINT OF ADVANCED CONTROL

1 Network Control Panel

Located in facility manager's office

- Large screen and four-button control provide a user-friendly interface to HVAC equipment and building functions.
- Customized settings with time-of-day scheduling, temperature, CO₂, ventilation and humidity control.
- Date and time-stamped alarm codes.
- Auto-poll start-up feature greatly reduces installation time and expense.
- Easily field-upgraded without losing programs or schedules.
- Provides a written description of each controller's alarm codes.



3 Prodigy® Unit Controller

Standard on Emergence® rooftop units

- Intuitive user interface makes setup, troubleshooting and servicing easier than ever.
- Each unit tracks the runtime of every major component and records the date and time when service or maintenance is performed.
- Intelligently operates the rooftop unit to help ensure reliability, maximum efficiency and comfort.

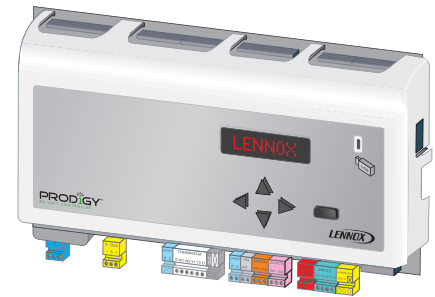

4 Network Thermostat Controller

Integrates electro-mechanically controlled HVAC equipment

- Monitors and controls Lennox' split systems and rooftop units without the Prodigy Unit Controller, as well as electro-mechanically controlled third-party equipment.
- Up to two-heat, three-cool capability.
- Can be combined with optional bypass controller for constant volume bypass zoning applications.
- Fused outputs and override switches simplify installation testing, set-up, and provide added protection.



CONTROLLERS CONNECT EQUIPMENT TO THE NETWORK

2 Building Controller

Located in control room or mechanical room

- Schedules basic building operations such as lights, signs and exhaust fans.
- Built-in diagnostics and alarm codes speed troubleshooting.



SYSTEM ARCHITECTURE (CONTINUED)

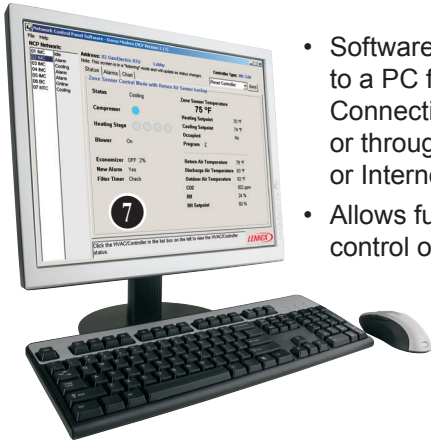

- Software sends information to a PC from the L Connection Network locally or through a remote modem or Internet connection.
- Allows full monitoring and control of the network.

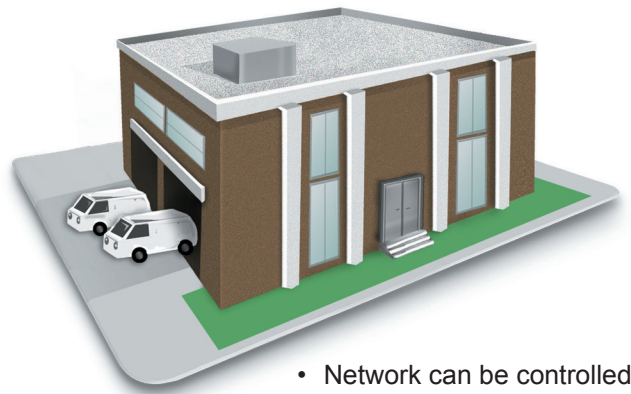

- Network can be controlled from a remote location.

ZONE CONTROLLERS AND SENSORS PROVIDE CONTROL AT EACH ZONE

5 Zone Link

Located in the rooftop unit or mechanical room

- Coordinates up to 31 Comfort Sensors connected to a zoned rooftop unit.
- Counts heating and cooling votes from Comfort Sensors and signals the rooftop unit to change modes according to its configuration.
- Expands L Connection Network to coordinate up to 93 unit controllers per network.



6 Comfort Sensor

Located in each zone

- Temperature sensor with optional relative humidity and/or carbon dioxide sensing capabilities.
- Controls zone damper or variable volume terminal box in zoning applications to maintain space temperature and indoor environmental quality.
- Optional LCD user interface with sensor readings and easy temperature adjustment.



SOFTWARE SENDS INFORMATION TO A PC FROM THE L CONNECTION® NETWORK LOCALLY OR REMOTELY

7 Unit Controller Software

- Commission, monitor and control unit controllers, including Prodigy® Unit Controllers, Network Thermostat Controllers or Building Controllers.
- Connects to the network locally or remotely through a modem, rough an Ethernet network or through the Internet (requires access to Local Area Network (LAN) via an Internet connection).



Network Control Panel Software

- Schedule, monitor and control the entire L Connection Network.
- Configures alarms to automatically send e-mail, page, or text message notification to a facility manager or servicing contractor before problems get out of hand.
- Records trends based on over 25 user-selectable data points that can be automatically graphed using Microsoft® Excel.
- Generates, saves and prints a variety of reports.
- Connects to the network locally or remotely through a modem, through an Ethernet network or via the Internet.



Network Modem

- Configured specifically for the L Connection Network.
- Plug-and-play device requires no modification.
- Use with L Connection Network software for access from a remote site.



Ethernet Converter

- Configured specifically for the L Connection Network.
- Allows users to monitor and control devices on the L Connection network through their existing Ethernet local area network (LAN).
- Can be used to monitor and control devices on the L Connection Network remotely through the Internet.
- Can be used with Unit Controller Software and/or Network Control Panel Software.



SYSTEM OVERVIEW

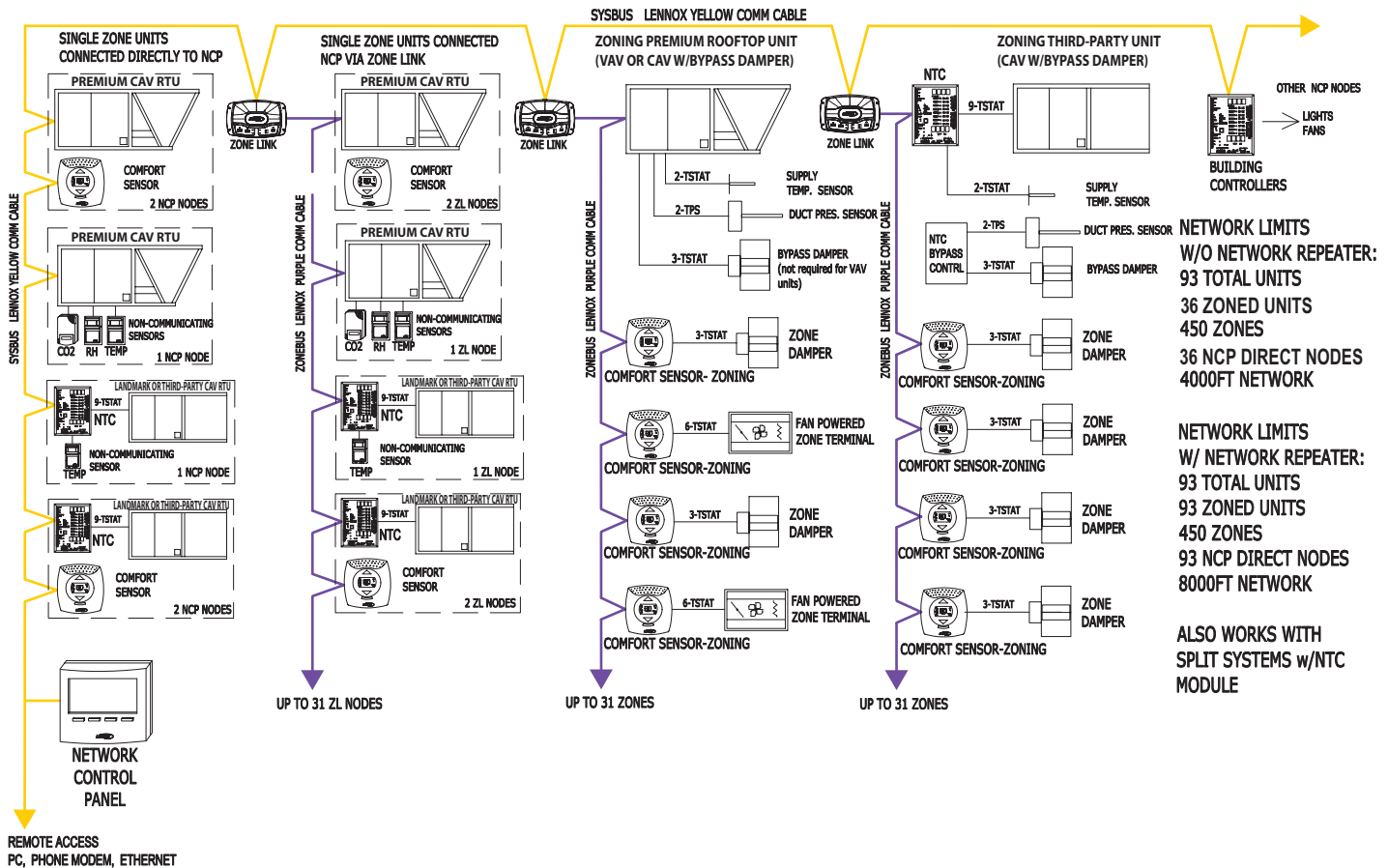

SYSTEM OVERVIEW

- The Network Control Panel is used to schedule building network operation on up to 450 HVAC zones and 12 Building Controllers.
- The Building Controller option adds capability for schedule or light sensor control for up to 8 outputs that can be used for lighting, fans, signage, etc.
- Up to 93 units per Network Control Panel.
- Integrates single zone and zoned units on the same network.
- Connects directly to Lennox' premium rooftop units.
- Uses Network Thermostat Controller to control rooftop units without the Prodigy® Unit Controller, split systems and third-party units.
- Many non-communicating space sensor options for temperature, relative humidity (RH) and CO₂.
- Comfort Sensor options add capability for single unit setpoint control, built-in RH and CO₂ sensors.
- Comfort Sensor-Zoning options add capability for zone terminal box control, built-in RH and CO₂ sensors.
- Access at Network Control Panel or via local PC.
- Remote access via phone modem or via LAN/ nternet with Ethernet Converter.

Zoning Applications

- Up to 31 zones/unit.
- Constant Air Volume Bypass (CAVB) and Variable Air Volume (VAV) zoning systems.
- Configurable for parallel and series fan powered terminal boxes.
- Fan boxes may be used with VAV or CAV rooftop unit.
- Can mix and match fan boxes, damper zones and single zones.
- Networked solution simplifies wiring.
- Lennox' variable air volume (VAV) units are zoning ready.

NOTE - One rooftop unit and one Comfort Sensor with the same address equals two zones. 15 units (with one Comfort Sensor per rooftop unit) is the maximum number of units allowed on the network cable without the use of a Zone Link (see page 30) or Network Repeater (see page 63).

NOTE - The L Connection® Network is not applicable to heat pump units or units equipped with the Humiditrol® option in multi-zone (Comfort Sensor Zoning) applications.

SYSTEM SELECTION FLOWCHARTS

SYSTEM COMPONENT SELECTION EXAMPLE - BASIC OVERVIEW

Lennox Rooftop Units With Prodigy® Unit Controller

(NOTE - Prodigy and Network Thermostat Controller controlled units can be combined on the same system)

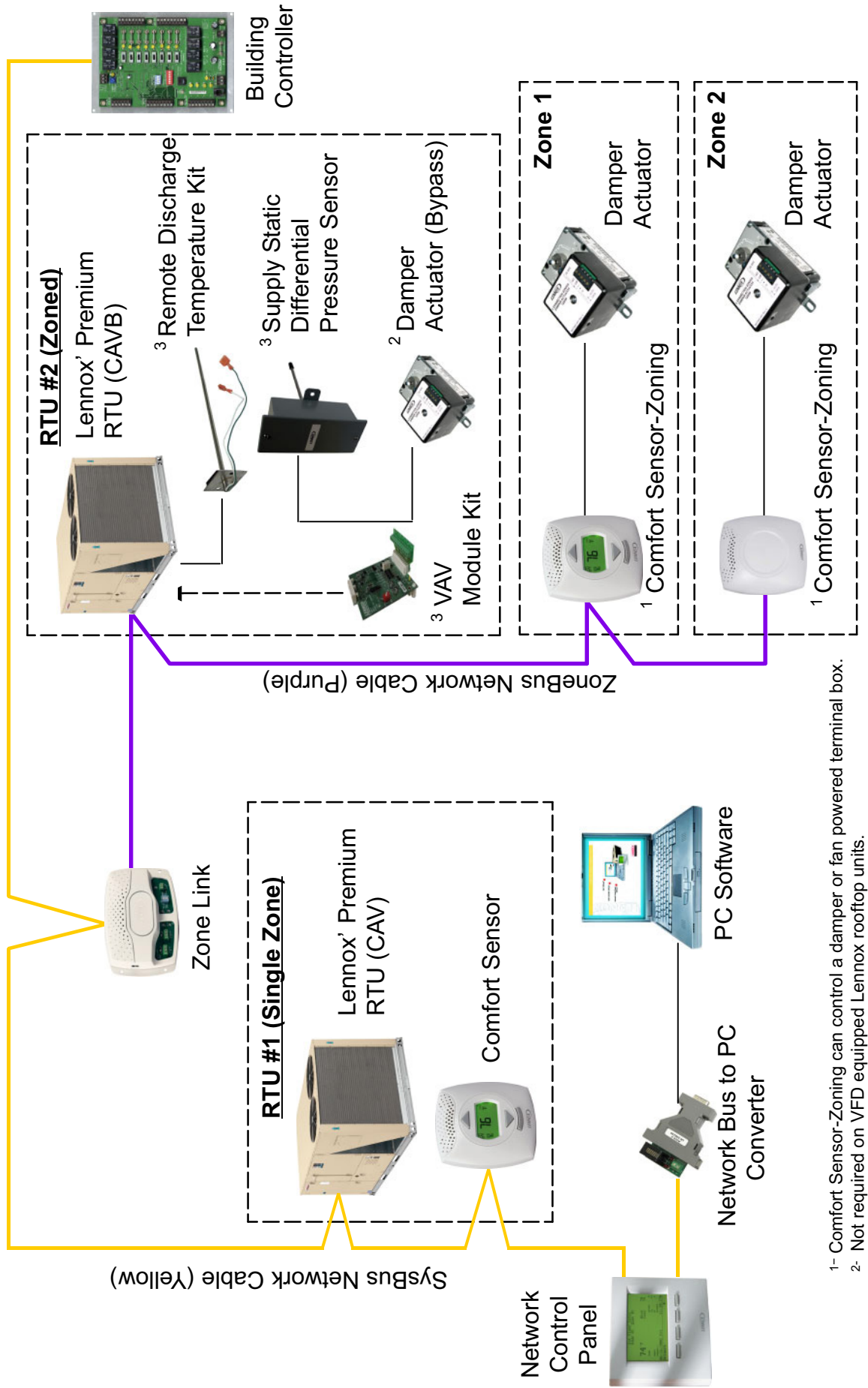

1- Comfort Sensor-Zoning can control a damper or fan powered terminal box.
 2- Not required on VFD equipped Lennox rooftop units.
 3- Automatically included with VFD equipped Lennox rooftop units.

BASIC COMPONENT SELECTION EXAMPLE
Lennox Rooftop Units With Prodigy® Unit Controller
 (NOTE – Prodigy and Network Thermostat Controller controlled units can be combined on the same system)

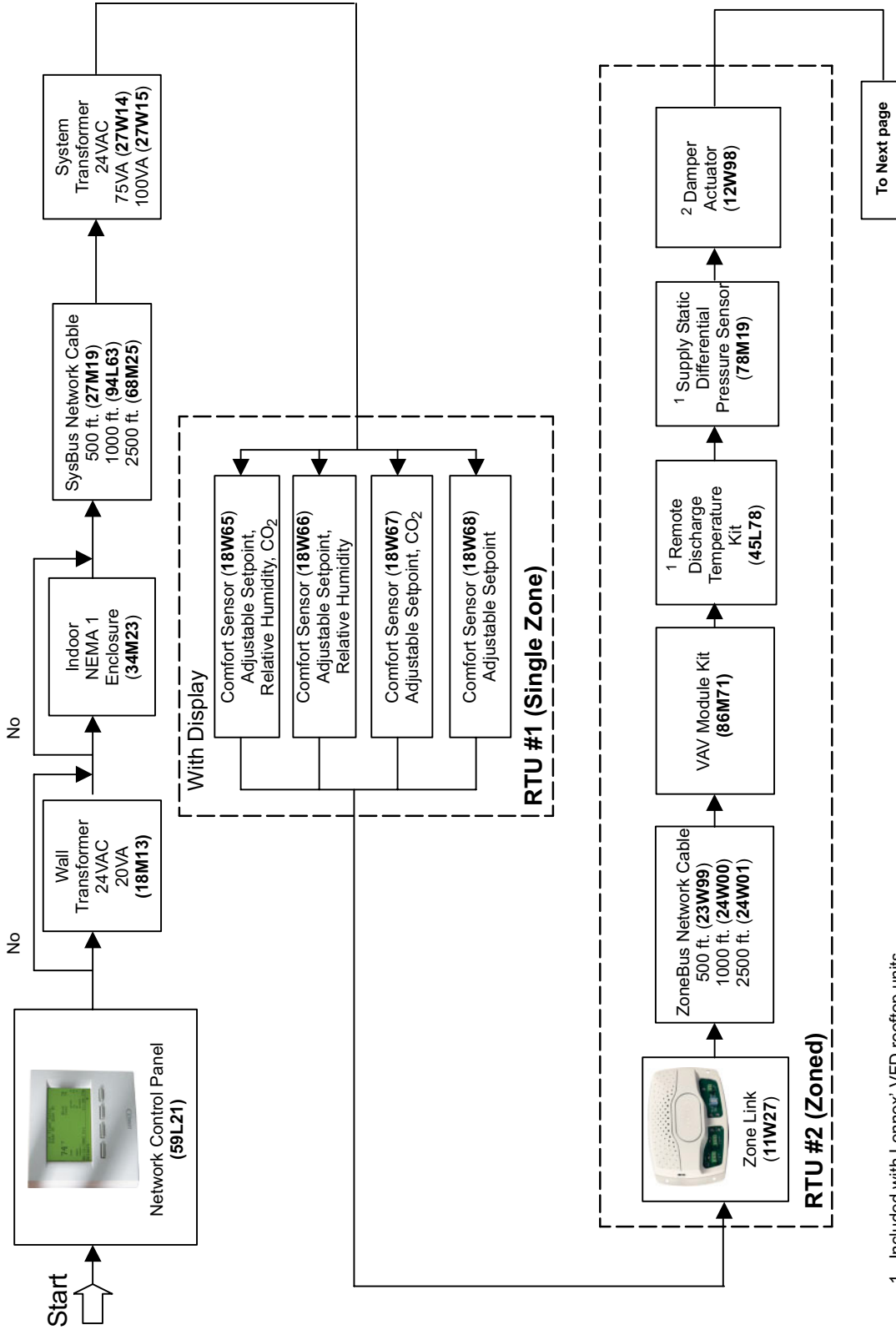

1 - Included with Lennox' VFD rooftop units.
 2 - See Pages 79-81 for damper selection.
 3 - 75VA and 100VA Transformers shown are recommended for powering Damper Actuators.

SYSTEM SELECTION FLOWCHARTS

BASIC COMPONENT SELECTION EXAMPLE

Lennox Rooftop Units With Prodigy® Unit Controller

(NOTE – Prodigy and Network Thermostat Controller controlled units can be combined on the same system)

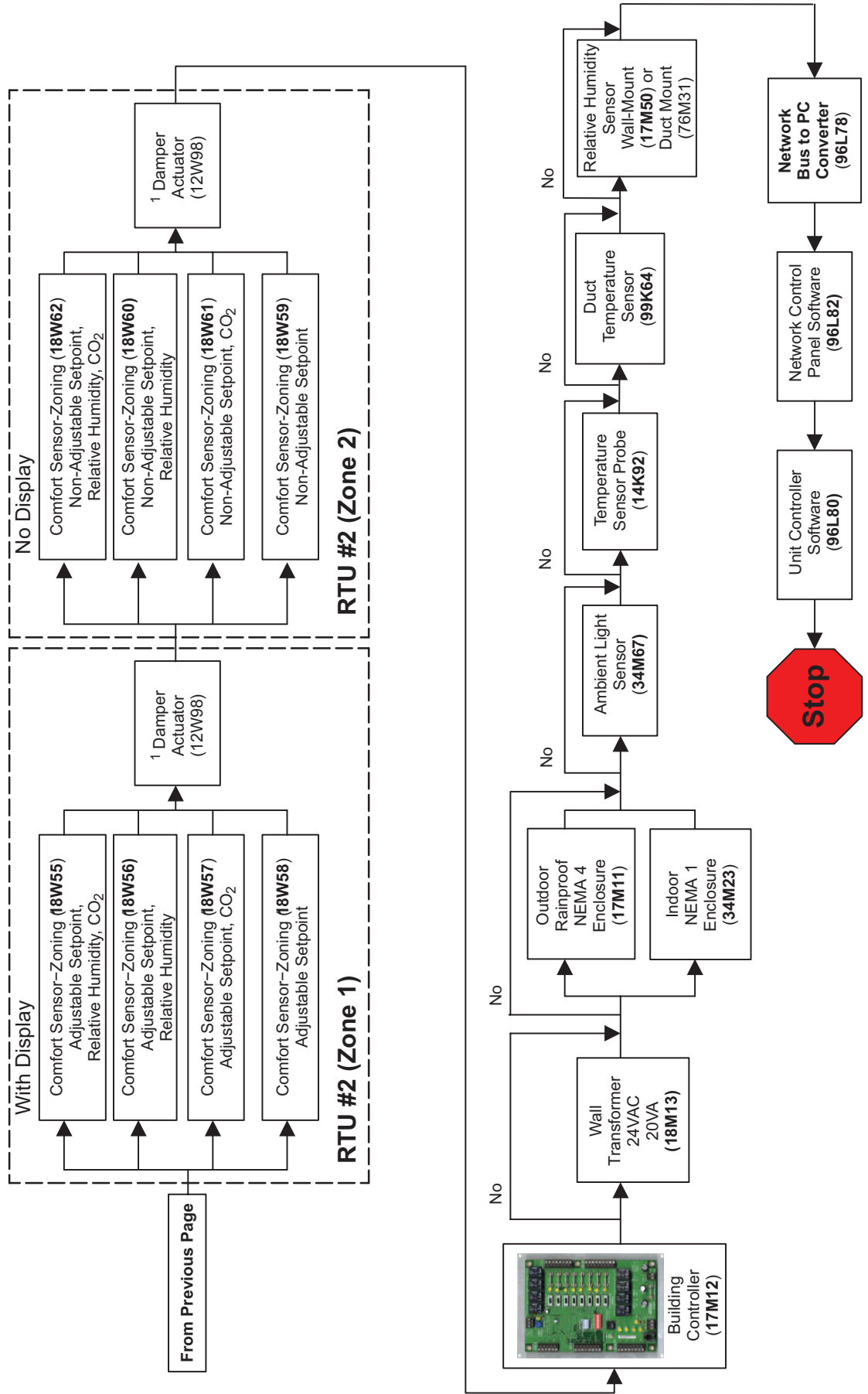

1 - 75VA and 100VA Transformers shown are recommended for powering Damper Actuators.

SYSTEM SELECTION FLOWCHARTS

COMPONENT SELECTION EXAMPLE – BASIC OVERVIEW
Network Thermostat Controller Version - For Lennox' Rooftop Units Without The Prodigy® Unit Controller
and Split Systems or Electro-Mechanically Controlled Third-Party Rooftop Units

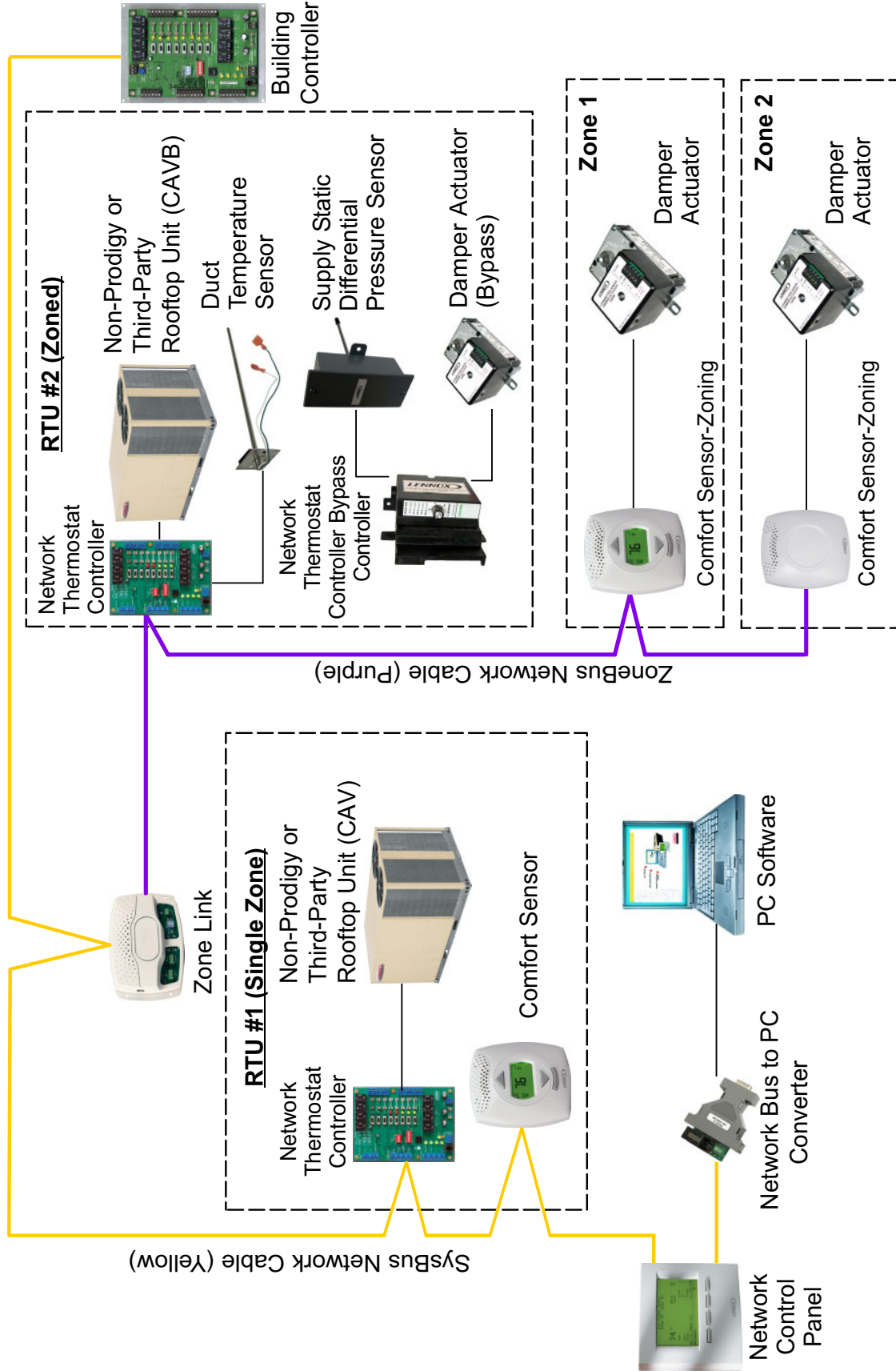

BASIC COMPONENT SELECTION EXAMPLE
Network Thermostat Controller Version - For Lennox' Rooftop Units Without The Prodigy® Unit Controller
and Split Systems or Electro-Mechanically Controlled Third-Party Rooftop Units

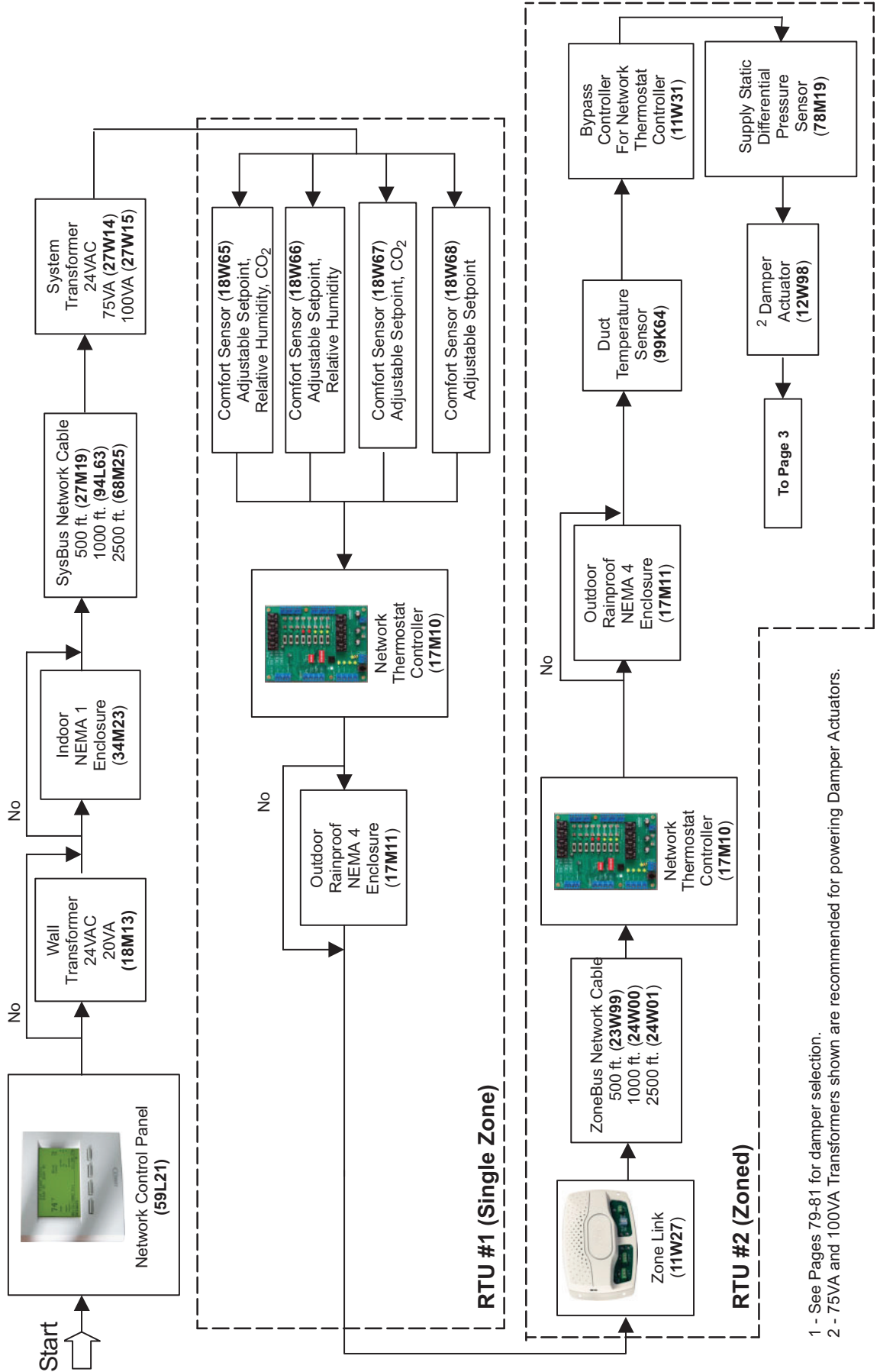

1 - See Pages 79-81 for damper selection.

2 - 75VA and 100VA Transformers shown are recommended for powering Damper Actuators.

BASIC COMPONENT SELECTION EXAMPLE
Network Thermostat Controller Version - For Lennox® Rooftop Units Without The Prodigy® Unit Controller
and Split Systems or Electro-Mechanically Controlled Third-Party Rooftop Units

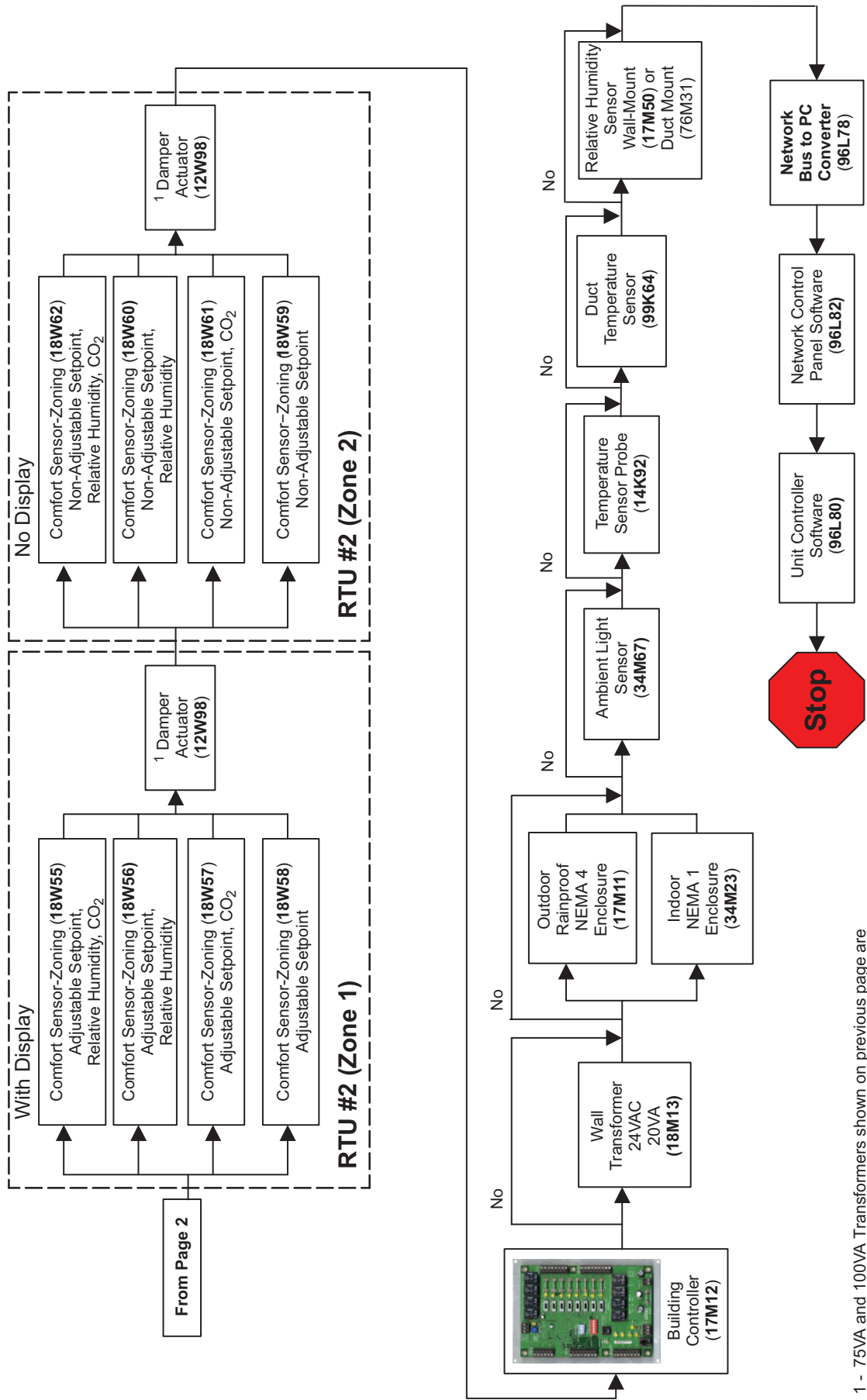

1 - 75VA and 100VA Transformers shown on previous page are recommended for powering Damper Actuators.

SYSTEM COMPONENTS - CONTROLLERS

BUILDING MANAGER

NETWORK CONTROL PANEL COCTRL10AE1L (59L21)



The **Network Control Panel** is the L Connection Network building automation system network manager. It offers sophisticated control and scheduling for up to 93 units operating in either single zone or zoned mode, up to a total of 450 zones. It can also control up to 12 Building Controllers for schedule control of lights, signs, sprinklers and exhaust fans.

Main Features

Control Functions

- Zone status screen displays zone temperature, setpoints, RH, CO₂, unit operation, alarm status, time/date, zone number, program and filter status.
- Adjustable override setpoints for each program
- Password protection.
- Adjust relative humidity (RH) for Lennox Humiditrol® units or units running in the Supermarket reheat mode.
- Permanent storage of all data.
- May also be used to monitor units that are controlled by thermostat or third-party system.
- When used with the Building Controller, it can schedule up to 8 outputs (example: lighting zones, exhaust fans, sprinklers, etc.) and display up to 3 analog and 4 temperature inputs with user-defined names.

Integrated System

- Control up to 93 different members on the L Connection Network.
- Field upgradeable flash memory
- Port for interfacing with the PC and L Connection PC software.
- Port for upgrading software (firmware).

Local Interface

- Large LCD display screen for viewing and editing functions.
- Keypad consists of four multi-task buttons used to enter and retrieve data using on-screen menus and commands:
 1. First button goes “back” to previous screen displayed (up a level).
 2. Second button scrolls “up” through current screen selections or increases a highlighted value on the current screen.
 3. Third button scrolls “down” through current screen selections or decreases a highlighted value on the current screen.
 4. Fourth button selects the current menu item highlighted or toggles between fields on the zone status screen.
- Backlit LCD display screen shows 26 different weekly programs (A-Z) for both the HVAC equipment and the Building Controllers. Also displays network status, time schedules and editing functions.
- Seven day independent programming plus holidays (up to 99 different day schedules for HVAC equipment and 50 for the Building Controllers).
- Six different time/temperature (°F or °C) schedules per day for up to 93 single zone units.
- Up to 50 dates can be entered as holidays and assigned to different day schedules.
- HVAC day schedules 1-2 and the weekly programs A-B are factory pre-set programs.
- May be remotely accessed and programmed through optional phone modem or Ethernet converter by PC running the Network Control Panel Software.

Plug and Play Installation

- Network Control Panel connects directly to the Prodigy® Unit Controller in the rooftop unit or to the Network Thermostat Controller for non-Prodigy® equipped products by Lennox or third-party equipment manufacturers and to the Building Controller for controlling other building functions.
 - Re-poll function automatically searches for and finds new equipment.
 - Terminal blocks for easy field wiring connections to power sources and the SysBus.

SPECIFICATIONS - NETWORK CONTROL PANEL

Operating Environment	Temperature: 0°F to 105°F Humidity: 10% - 95% RH, Non-Condensing
Power Requirements	24VAC (+/-25%), 50/60Hz, 5VA Class 2 transformer required
Device Commissioning	Auto-poll (real plug and play)
Clock	Internal real time clock and calendar with 10 year backup battery.
Memory Type	Re-programmable Flash
Number of Programs	26 (A-Z)
Number of Day Schedules	99 (1-99)
Setpoint Changes/Day	Up to 6
Number of Holidays Stored	Up to 50
Number of Scheduled Units	Up to 93
Number of Scheduled Zones	Up to 450
Number of Alarms Stored	Up to 84 devices (7812 total)
Display Type	Graphical Liquid Crystal (LCD) with Green LED backlight
Indicator LEDs	1- Heartbeat 1- Bus transmit
Dimensions	Height: 5-7/8 in. Width: 6-5/8 in. Depth: 1-11/16 in.
Weight	0.80 lbs.
Enclosure	High impact ABS off-white plastic case

INPUTS / OUTPUTS

Bus Port	Lennox SysBus, EIA-485, 9600 baud (Field wiring terminal block on base and phone jack located on bottom of control)
COM Port	RS-232 (Accessed on bottom of control. Only used for field upgrading of firmware)
Cable Type	SysBus - Lennox yellow COMM cable: COMISC00AE1- (27M19) (500 ft. box), COMISC04AE1- (94L63) (1000 ft. box), COMISC01AE1- (68M25) (2500 ft. roll) 24VAC Power - 2 Conductor Thermostat 22 AWG min. (wire gauge depends on distance from transformer) COM Port - Requires special cable furnished with the Network Control Panel Service Pack

NETWORK CONTROL PANEL - FIELD WIRING

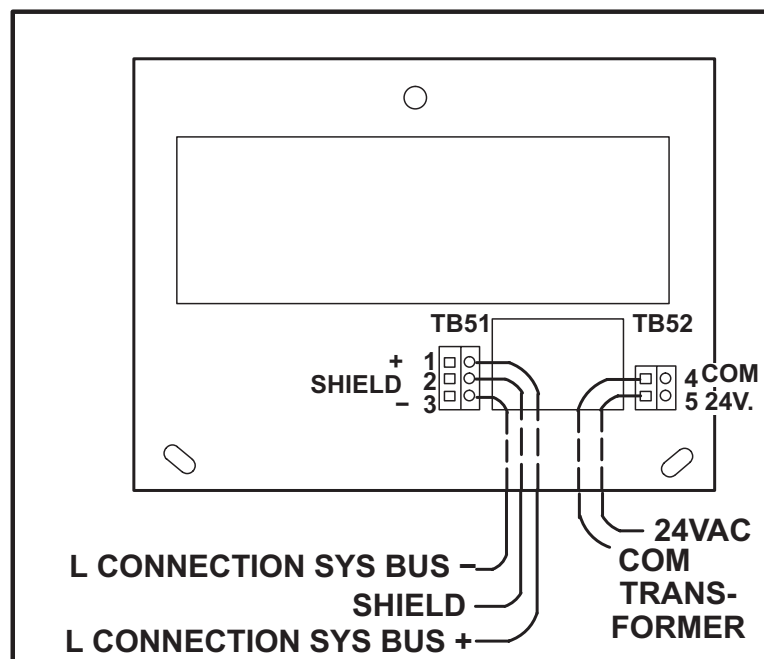

PRODIGY® UNIT CONTROLLER



The Prodigy Unit Controller is a microprocessor-based control board that provides flexible control of all unit functions.

All control voltage is provided via a 24V (secondary) transformer with built-in circuit breaker protection.

The Prodigy Unit Controller features:

Scrolling Display - Display scrolls full text instead of numerical codes to help simplify diagnosing and troubleshooting. The high contrast display makes it easy to read in various lighting and ambient conditions.

Push Buttons - Offer simplified navigation during setup and diagnostics. Arrow buttons (no DIP switches) simplify setup and installation by making menu navigation very intuitive

Guided Setup - The Prodigy Unit Controller features a guided setup procedure that speeds up and helps insure proper installation and setup of the rooftop unit.

USB Port - Allows a technician or user to easily download and transfer unit information (with a time/date stamp and unit serial number) via a USB flash drive to help verify service was performed. A second USB port also offers an easy interface with a PC and the Lennox Unit Controller Software.



Unit Profile - A Unit Profile can also be saved to a USB flash drive and then uploaded to an identical unit, instantly copying all setpoints.

Self-Test - Unit Controller performs self-test to verify individual critical component and system performance. Included is an economizer test function that helps assure the economizer is operating correctly.

Time Clock with Run-time Information - Internal time clock with runtime information on these key components:

- Power Applied
- UV Lamp
- Condenser Fan(s)
- Exhaust Fan
- Filter
- Blower
- Heat Stage(s)
- Dehumidification
- Blower Belt
- Compressor(s)
- Free Cooling

Built-In Functions Include:

Blower On/Off Delay - Adjustable time delay between blower on and off.

Built-in Control Parameter Defaults - No programming required.

Compressor Time-Off Delay - Adjustable time delay between compressor shutoff and start up.

DDC Compatible - Various third party DDC controllers can be factory or field installed.

Dirty Filter Switch Input - When a Dirty Filter Switch is installed, the control will signal when the indoor blower static pressure increases, indicating a dirty filter condition. Switch is optional and can be factory or field installed.

Discharge Air Temperature Control - The controller will cycle up to 4 stages of heating or cooling to maintain the discharge air setpoints for heating or cooling. Optional sensor for remote field installation in the supply duct.

Display/Sensor Readout - Displays control parameters, text status messages, and sensor readings. The unit controller displays temperature readings from return air, supply air, and outdoor air sensors that are furnished as standard on all Emergence® units. Controller will also display readings from optional sensors such as zone sensors, CO₂ sensors or relative humidity sensors.

Economizer Control Choice - The economizer is controlled by the Prodigy Unit Controller. The control has several options for controlling the economizer.

PRODIGY® UNIT CONTROLLER (continued)

Fresh Air Tempering - Provides heating and cooling as needed to maintain the supply air temperature within a comfort range, regardless of the thermostat demand. Sensor ships with unit but must be field installed in the supply air duct. Requires change to setpoint in the field to activate this mode of operation

Extensive Unit Diagnostics - The Prodigy Unit Controller monitors all sensors and functions related to unit operation to provide critical information. The controller will display detailed diagnostic information with over 100 diagnostic and status messages to pinpoint any problems and reduce troubleshooting time. All diagnostic messages and status alarms are displayed in plain English.

Exhaust Fan Control Modes - Fans controlled by fresh air damper position or building static differential pressure transducer.

Permanent Diagnostic Code Storage - Stores last 84 diagnostic messages even in the event of a power failure.

Field Changeable Control Setpoints - Over 200 different control setpoints allow customizing of the unit operation by changing delays, cooling stages, deadbands, and other comfort control parameters.

Indoor Air Quality Input - The Prodigy Unit Controller is Demand Control Ventilation ready from the factory (optional field installed CO₂ sensor required). Two modes of operation are available: setpoint and proportional.

1. **Setpoint** - Opens the economizer dampers to full position when CO₂ setpoint level is reached.
2. **Proportional** - Opens the dampers at the first set point and gradually increases it as the CO₂ level increases until the second setpoint is reached.

Low Ambient Controls - Allows unit cooling operation down to 0°F.

Gas Valve Time Delay Between First and Second Stage - Allows gradual increase of input rate.

Minimum Compressor Run Time - Ensures proper oil return to the compressor.

Network Capable - The Prodigy Unit Controller can be daisy chained to other Emergence Rooftop Units or the L Connection® Network Control System using twisted pair wire.

Night Setback Mode - Adjusts setpoints, closes outdoor air dampers and operates the blower on demand, may be customized for special requirements.

Return Air Temperature Limit Control - Allows the user to override the demands based upon the return air temperature during either heating or cooling operation. Helps protect against abnormal operating conditions in the event of a room sensor or thermostat failure.

Safety Switch Input - Normally-closed digital input allows the Prodigy Unit Controller to respond to a external safety switch trip (phase protector, low voltage, etc.) shutting down unit operation.

Service Relay Output - Digital output can indicate a critical error has occurred to an external control device. Can also be configured to energize based on relative humidity, indoor air quality, outdoor air temperature or unit operation.

Smoke Alarm Mode - Control board has four choices for responding to a smoke alarm.

1. **Unit Off** - unit will turn off.
 2. **Positive Pressure** - blower is energized, exhaust fan is de-energized, and the outdoor air dampers are opened.
 3. **Negative Pressure** - blower is energized, exhaust fan is energized, and the outdoor air dampers are closed.
 4. **Purge** - blower is energized, exhaust fan is energized, and the outdoor air dampers are opened.
- Staging - 2 heat/2 cool. Capable of up to 4 heat/4 cool with zone sensor or third party DDC control system.
 - “Strike Three” Protection - Ends cooling or heating operation when any of the following occurs three times (adjustable) within a thermostat cycle: low pressure trip, high pressure trip, heat limit trip, blower proving, or freezestat trip.
 - Gas Reheat - Control parameter option that allows simultaneous heating and cooling operation for controlling humidity for process air applications such as supermarkets. Field installed relative humidity sensor or dehumidistat can be used.
 - On Demand Dehumidification - Monitors and controls condenser hot gas bypass operation with Humiditrol® option. Prioritizes heat and cool demand with dehumidification demand. Reheat demand can be enabled by digital input or a field installed relative humidity sensor can be used.
 - Thermostat Bounce Delay - Protects compressor from short cycling when mechanical thermostat is used.
 - Warm Up Mode Delay - Adjustable time that the economizer dampers are kept in the closed position during morning warm-up.
 - LED Indicators - For L Connection Network (transmit and receive) and for each thermostat input.
 - PC Interface - PC with optional Unit Controller software may be used to field or remotely adjust parameters, read alarms, or display unit status.
 - Zone Sensor Operation - Controls zone temperature with up to 4 stages of heating or cooling with optional zone sensor.

SPECIFICATIONS - PRODIGY UNIT CONTROLLER

Operating Environment	Temperature: -40°F to 155°F
	Humidity: 10% - 95% RH, Non- Condensing
Power Requirements	24VAC (+/-25%), 50/60Hz
	4.8 VA for M2 maximum
	14.4 VA for M2 w/all expansion boards Maximum
Memory Type	Re-programmable Flash
Device Commissioning	Auto-poll (real plug and play)
Unit type	Electric/Electric, Gas/Electric & Heat Pumps (Rooftops)
Cooling stages	4
Heating stages	2 (gas), 4 (electric)
Modulating Gas Valves	2
Electronic Configure To Order Parameters	239
Alarm Codes	107
Alarm Codes Stored	84
Display Type	Scrolling, 7 plus Character Red LED
Indicator LEDs	1- Heartbeat on each board
	1- Bus transmit
	1 - Bus receive
	1- each for Y1,Y2,W1,W2,G,OCP
Dimensions - Main Board	Main Board: Height: 8 in., Width: 14-1/2 in., Depth: 6 in.
Weight	2 lbs. for M2 w/all modules installed
Cable Type	SysBus - Lennox yellow COMM cable: COMISC00AE1- (27M19) (500 ft. box), COMISC04AE1- (94L63) (1000 ft. box), COMISC01AE1- (68M25) (2500 ft. roll) ZoneBus - Lennox purple COMM cable: COMISC05AE1- (23W99) (500 ft. box) COMISC06AE1- (24W00) (1000 ft)

INPUTS / OUTPUTS - PRODIGY UNIT CONTROLLER

INPUTS / OUTPUTS (M2 MAIN BOARD)

Bus Port	Lennox SysBus, EIA-485, 9600 baud (SmartWire™ wiring terminal block and phone jack) USB Communication Port
Expansion Ports	3 expansion ports for adding up to 5 expansion boards
Digital Outputs	15 digital outputs (2 Amps Max)
Digital Inputs	27 (24VAC), 6 (5VDC)
Analog Inputs	5 analog inputs (0-10VDC or 4-20 mA)
Temperature Inputs	4 temperature inputs (thermistor type). Outdoor Air, Return Air, Discharge Air and Zone.

INPUTS / OUTPUTS (M2 VAV, MODULATING GAS AND I/O MODULES)

For Emergence® 092 through 600 (7.5 through 50 Ton) Models Only

Expansion Ports	1 expansion port
Digital Outputs	1 relay output (1 Amps Max)
Digital Inputs	2 digital inputs (24VAC)
Analog Inputs	4 analog inputs (0 to 10VDC)
Analog Outputs	2 analog outputs (0 to 10VDC)

INPUTS / OUTPUTS (M2 #3 and #4 COMPRESSOR MODULE)

Expansion Ports	1 expansion port
Digital Outputs	6 relay output (2 Amps Max)
Digital Inputs	8 digital inputs (24VAC)

INPUTS / OUTPUTS (MOTOR CONTROL MODULE)

Expansion Ports	1 expansion port
Digital Outputs	3 digital inputs
Digital Inputs	1 digital input, frequency
Analog Outputs	2 analog outputs (includes pwm)

VAV MODULE KIT

COCTRL02AE1L (86M71)

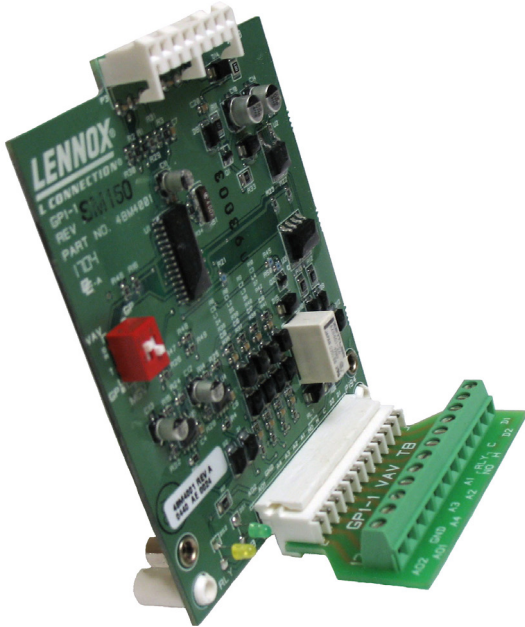

The **VAV Module Kit** is used with rooftop units containing a Prodigy® Unit Controller. The kit is used to control an optional field installed supply bypass damper for zoning applications. The kit includes a plug-on screw terminal block for field wiring.

Main Features of the VAV MODULE KIT

- Expansion board for the Prodigy Unit Controller.
- Allows inputs/outputs for controlling bypass damper for zoning applications.
- Compatible with Lennox Damper Actuator.
- Compatible with Lennox Duct Static Pressure Sensor.
- 13 ECTO options in the Prodigy Unit Controller for controlling Bypass damper:
 1. Supply static setpoint for cooling.
 2. Supply static setpoint for heating.
 3. Supply static setpoint for ventilation.
 4. Supply static setpoint for smoke alarm.
 5. Bypass Damper minimum position for cooling ventilation and smoke alarm.
 6. Bypass Damper minimum position for heating.
 7. Bypass Damper maximum position.
 8. Bypass Damper position when unit is off.
 9. Proportional (P) loop constant.
 10. Integral (I) loop constant.
 11. Derivative (D) loop constant.
 12. Supply static pressure limit.
 13. Supply static pressure limit lockout counts.
- Field wiring screw terminal block included.

Sequence of Operation

The VAV Module monitors the supply static pressure from the pressure sensor and reports it to the Prodigy Unit Controller. The controller compares that reading to the supply static pressure setpoints stored in the Prodigy ECTO parameters. The controller then modulates the bypass damper voltage output on the VAV Module to control the unit's supply static pressure based on the Prodigy PID loop ECTO parameter settings.

The VAV Module has 3 additional analog inputs, 1 digital output (relay), 2 digital inputs and 1 analog output that may be used for general purposes.

SPECIFICATIONS - VAV MODULE KIT

Prodigy Unit Controller Compatibility	All
Network Control Panel Compatibility	Version 1.17 or higher
Unit Controller PC Software Compatibility	Version 2.06 or higher
Network Control Panel PC Software Compatibility	Version 2.06 or higher
Operating Environment	Temperature: -40°F to 155°F Humidity: 10% - 95% RH, Non- Condensing
Power Requirements	24VAC (+/-25%), 50/60Hz (from the Prodigy® Unit Controller) 10mA maximum 5VDC +/-5% (from the Prodigy® Unit Controller) 7mA maximum
Indicator LEDs	1- Heartbeat 1- Relay output
Dimensions	Height: 4 in. Width: 3-1/2 in. Depth: 1 in.
Weight	0.19 lbs.

INPUTS / OUTPUTS

Expansion Ports	1 expansion port
Digital Outputs	1 relay output for general purpose use.
Digital Inputs	2 digital inputs (24VAC) for general purpose use
Analog Inputs	4 analog inputs (0 to 10VDC), 1 for duct static pressure , 3 for general purpose use.
Analog Outputs	2 analog outputs - 1 for controlling bypass damper actuator (2-10VDC), and 1 for general propose use (0-10VDC)
Cable Type	Digital Outputs - Thermostat cable, 22 AWG min. (wire gauge depends on distance) Digital Inputs - Thermostat cable, 22 AWG min. (wire gauge depends on distance). Analog Inputs - Lennox COMM cable Analog Outputs - Thermostat cable, 20 AWG min. for bypass damper (wire gauge depends on distance)

VAV MODULE KIT - FIELD WIRING

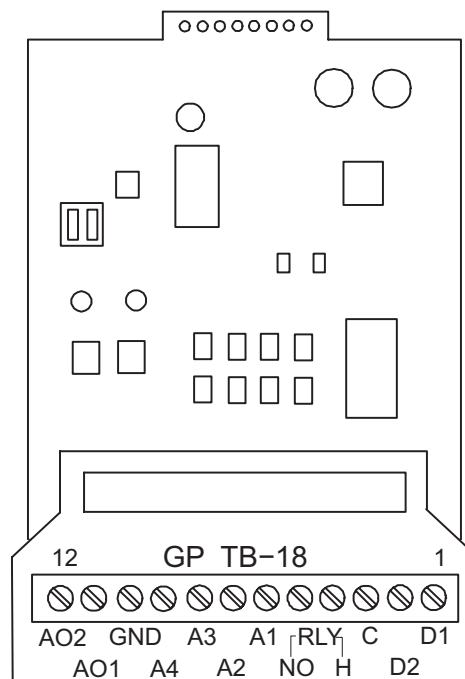

I/O MODULE KIT

COCTRL01AE1L (86M39)

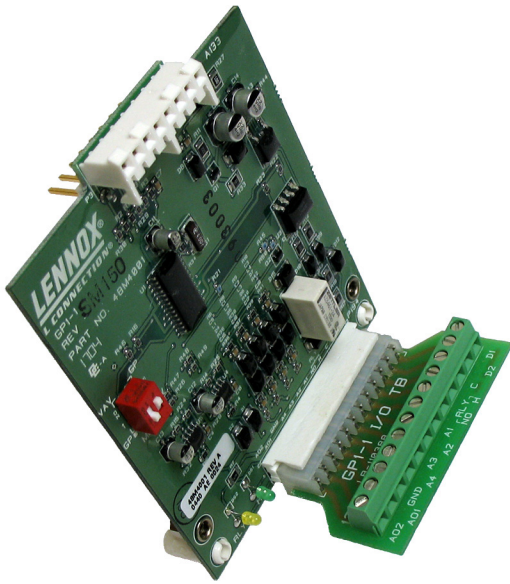

The **I/O Module Kit** is used with rooftop units containing a Prodigy® Unit Controller. The kit is used to control field installed options. It has two analog outputs with PID control for controlling analog devices or variable equipment. It has four analog inputs that can be used to monitor analog sensors or devices. It also has one digital output that can be controlled based upon the unit's operation or an analog input signal.

Main Features of the I/O MODULE KIT

- Expansion board for the Prodigy Unit Controller.
- Allows inputs/outputs for controlling field applications. 25 ECTO options in the Prodigy Unit Controller for controlling I/O Module outputs.
 - Control digital output based on:
 - Unit occupied.
 - Blower on.
 - Heating demand.
 - Cooling demand.
 - Heating or cooling demand.
 - Digital input.
 - System RH level.
 - System CO₂ level.
 - Outdoor temperature level.
 - Analog input level (AI1-AI4).
 - Analog output level (AO1 or AO2).
 - Analog output based on:
 - PID control (2).
 - Staged.
- Field wiring screw terminal block included.

Sequence of Operation

The I/O Module has two analog PID loops. One compares the analog output (AO1) to the input (A1), and the second one compares the analog output (AO2) to the analog input (A2). All control parameters are adjustable by using the ECTO parameters in the Prodigy Unit Controller.

The two outputs (AO1, AO2) may also be staged on to an adjustable voltage based on occupancy, blower operation or based on the digital inputs (D1, D2).

The module also has two other analog inputs (A3,A4) that may be used to monitor any 0-10VDC analog sensor or input. If no PID loops are used all four analog inputs may be used for monitoring.

The module also has one digital output (24VAC relay). The relay is controlled based on the Prodigy® Unit Controller ECTO parameter.

Control options include:

- On or off during occupied.
- On or off when blower is energized.
- On or off when heating demand.
- On or off when cooling demand.
- On or off when heating or cooling demand.
- On or off at space RH setpoint.
- On or off at CO₂ setpoint.
- On or off at outdoor temperature setpoint.
- On or off based on setpoints of analog inputs (A1,A2,A3,A4).
- On or off based on setpoint of analog outputs (AO1,AO2).

Each control option also has a delay on and/or delay off option as well as adjustable hysteresis.

SPECIFICATIONS - I/O MODULE KIT

Prodigy Unit Controller Compatibility	All
Network Control Panel Compatibility	Version 1.17 or higher
Unit Controller PC Software Compatibility	Version 2.06 or higher
Network Control Panel PC Software Compatibility	Version 2.06 or higher
Operating Environment	Temperature: -40°F to 155°F Humidity: 10% - 95% RH, Non- Condensing
Power Requirements	24VAC (+/-25%), 50/60Hz (from the M1-7 or higher) 10mA maximum 5VDC +/-5% (from the M1-7 or higher) 7mA maximum
Indicator LEDs	1- Heartbeat 1- Relay output
Dimensions	Height: 4 in. Width: 3-1/2 in. Depth: 1 in.
Weight	0.19 lbs.

INPUTS / OUTPUTS

Expansion Ports	1 expansion port (plugs into M1-7 or higher)
Digital Outputs	1 relay output (1Amp @ 24VAC)
Digital Inputs	2 digital inputs (24VAC, 2.4K ohm load)
Analog Inputs	4 analog inputs (0 to 10VDC, 4K ohm load)
Analog Outputs	2 analog outputs (0 to 10VDC, 30mA maximum)
Cable Type	Digital Outputs - Thermostat cable, 22 AWG min. (wire gauge depends on distance) Digital Inputs - Thermostat cable, 22 AWG min. (wire gauge depends on distance). Analog Inputs - Lennox COMM cable Analog Outputs - Lennox COMM cable for VFDs, Thermostat cable 20AWG min. for bypass damper (wire gauge depends on distance)

I/O MODULE KIT - FIELD WIRING

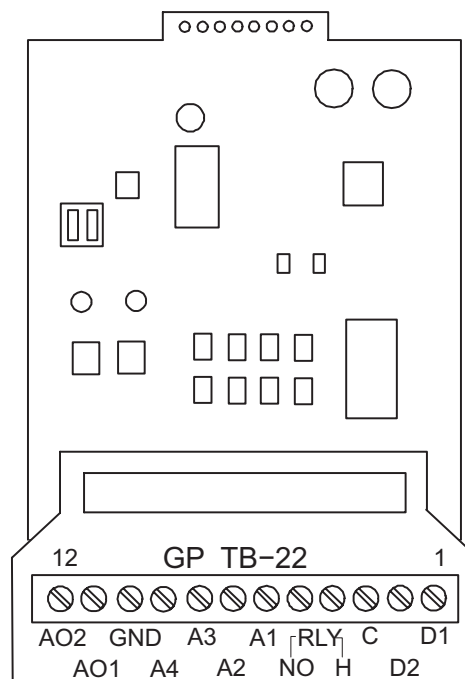

NETWORK THERMOSTAT CONTROLLER

COCTRL07AE1L (17M10)

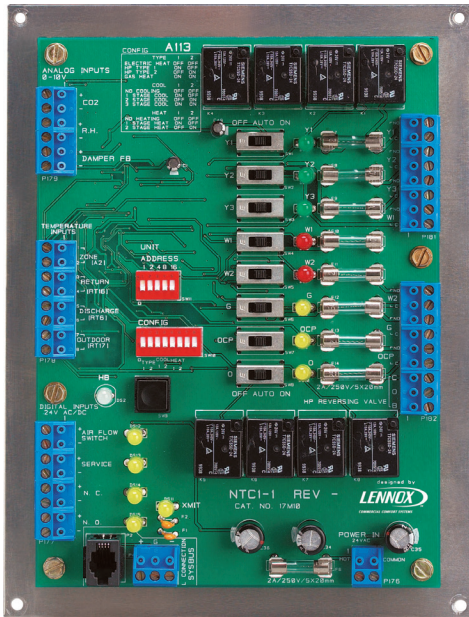

The **Network Thermostat Controller** is a direct digital controller (DDC) that provides general monitoring and control capabilities for HVAC equipment for the L Connection Network building automation system. It can control most electro-mechanically controlled equipment up to 3 stages of cooling and two stages of heating. The Network Thermostat Controller may be configured by changing its software parameter (ECTOs) for discharge air control operation, typically used for zoning applications. It can be used to control both non-Lennox equipment and Lennox equipment that is not equipped with the Prodigy® Unit Controller.

The Network Thermostat Controller has test switches and LED indicators for easy testing and diagnostics for each output. It also has LED indicators for each digital input.

Main Features of the Network Thermostat Controller

- Compatible equipment includes:
 - Packaged rooftop units
 - Air handlers
 - Split systems
 - Commercial and residential products
- Multiple settings and controls options allow for advanced control:
 - Up to 2H/3C staging for flexible temperature control.
 - Occupied output for controlling day/night operation.
 - Discharge Air Control for zoning applications.
- 50 optional control parameters (ECTOs).
- 25 alarm codes permanently stored in memory.
- Adjustable options including supplemental heat lockout temperature, heating and cooling on/off blower delays, low ambient lockout, and compressor off delay.
- Plug-able screw terminal blocks.
- Operates over a single communication link.
- Components are clearly labeled.
- Two color heartbeat LED indicates proper functioning.
- Push button for bypassing time delays and resetting control.
- Return air temperature limits options.
- Field upgradeable flash memory
- Four temperature sensor inputs including zone, return air, discharge air and outdoor sensor inputs (sensors ordered separately).
- CO₂ and RH analog inputs (0-10VDC) for monitoring (CO₂ and RH sensors ordered separately).
- Damper position analog input (2-10VDC).
- Air flow proving switch input for optional air flow switch.
- Normally open switch input (may be set up as optional smoke detector input)
- Normally closed switch input (may be set up as optional blower overload or loss of phase protector input).
- Service relay input (may be set up as optional dirty filter input).
- Reversing valve “O” and “B” outputs for controlling heat pumps.
- Occupied output for enabling economizer.
- Optional weatherproof NEMA 4 enclosure: C0MISC10AE1- (**17M11**) and NEMA 1 enclosure C0MISC13AE1- (**34M23**) are available.

SPECIFICATIONS - NETWORK THERMOSTAT CONTROLLER

Network Control Panel Compatibility	Version 1.11 or higher
Unit Controller PC Software Compatibility	Version 2.02 or higher
Network Control Panel PC Software Compatibility	Version 2.02 or higher
Device Commissioning	Auto-poll (real plug and play)
Operating Environment	Temperature: -40°F to 155°F Humidity: 10% - 95% RH, Non- Condensing
Power Requirements	24VAC, +/- 25%, 50/60Hz, 2VA Class 2 transformer required
Indicator LEDs	1 - Heartbeat 1 - Bus transmit 1 - Air Proving Switch Input 1 - Service Relay Input 1 - N.O. Shutdown Input 1 - N.C. Shutdown Input 1 - Each for Y1, Y2, Y3, W1, W2, G, O, C, P, O(B) thermostat outputs
Memory Type	Re-programmable Flash
Unit type	Gas/Electric, Electric/Electric and Heat Pumps (rooftop or split systems)
Cooling stages	3
Heating stages	2
Dimensions	Height: 8-1/2 in. Width: 6-1/2 in. Depth: 1-1/2 in.
Weight	1.10 lbs.
Electronic Configure To Order Parameters	50
Alarm Codes	25
Alarm Codes Stored	84

SPECIFICATIONS - NETWORK THERMOSTAT CONTROLLER (CONTINUED)

INPUTS / OUTPUTS

Bus Port	Lennox SysBus, EIA-485, 9600 baud (Field wiring terminal block and phone jack). Note: May connect to ZoneBus if under Zone Link.
Digital Outputs	8 relay contact outputs (Y1, Y2, Y3, W1, W2, G, O/B, ECON Enable) rated at 24V, 2amp. Each contact is fused and has a manual switch option for on, off or auto. Each output has LED indicator.
Digital Inputs	<ol style="list-style-type: none"> 1. Blower proving switch. Rated for 24VAC or DC. LED indicator. Compatible with Blower Proving Switch Kit C0SWCH01AE1- (30K49). 2. Service relay digital input. Rated for 24VAC or DC. LED indicator. May be set up as Dirty filter input. Compatible with Blower Proving Switch Kit C0SWCH01AE1- (30K49). 3. N.O. switch "shutdown" digital input. Rated for 24VAC or DC. LED indicator. May be set up as Smoke detector input. 4. N.C. switch "shutdown" digital input. Rated for 24VAC or DC. LED indicator. May be set up as blower overload or loss of phase protector input.
Analog Inputs	<ol style="list-style-type: none"> 1. 0-10VDC input for monitoring damper position. 2. 0-10VDC input for monitoring CO₂ sensors. Compatible with CO₂ Sensors C0SNSR50AE1L (77N39), C0SNSR52AE1L (87N53), C0SNSR51AE1L (87N52), C0SNSR53AE1L (87N54). 3. 0-10VDC input for monitoring RH. Compatible with Remote Humidity Sensor Kit C0SNSR31AE1- (17M50) and Duct Mount RH Sensor C0SNSR30AE1- (76M31).
Temperature Inputs	<ol style="list-style-type: none"> 1. Zone Sensor (must be used if any heating or cooling stages are set). Compatible with Non-Communicating Zone Sensors C0SNAJ01AE1- (56L80), C0SNZN07AE1- (94L60), C0SNZN08AE1- (94L61), C0SNDC02AE1- (56L81), C0SNZN71AE1- (23M20). 2. Return air sensor. Must be present if return air limit option is used. Compatible with Duct Temperature Sensor C0SNDC04AE1- (99K64). 3. Discharge air sensor. Must be present if Discharge Air Control mode used for zoning. Compatible with Duct Temperature Sensor C0SNDC04AE1- (99K64). 4. Outdoor air sensor. Must be present if compressor low ambient option is used. Compatible with Outdoor Temperature Sensor C0SNSR02AE1- (59M05).
Cable Type	<p>SysBus - Lennox yellow COMM cable: C0MISC00AE1- (27M19) (500 ft. box), C0MISC04AE1- (94L63) (1000 ft. box), C0MISC01AE1- (68M25) (2500 ft. roll)</p> <p>ZoneBus - Lennox purple COMM cable: C0MISC05AE1- (23W99) (500 ft. box) C0MISC06AE1- (24W00) (1000 ft. box) C0MISC07AE1- (24W01) (2500 ft. roll)</p> <p>24VAC Power - 2 Conductor thermostat 22 AWG min. (wire gauge depends on distance from transformer)</p> <p>Digital Outputs - Thermostat cable 22 AWG min. (wire gauge depends on distance)</p> <p>Digital Inputs - Thermostat cable 22 AWG min. (wire gauge depends on distance.)</p> <p>Analog Inputs - Lennox COMM cable</p> <p>Temperature Inputs - Lennox COMM cable</p>

NETWORK THERMOSTAT CONTROLLER - FIELD WIRING

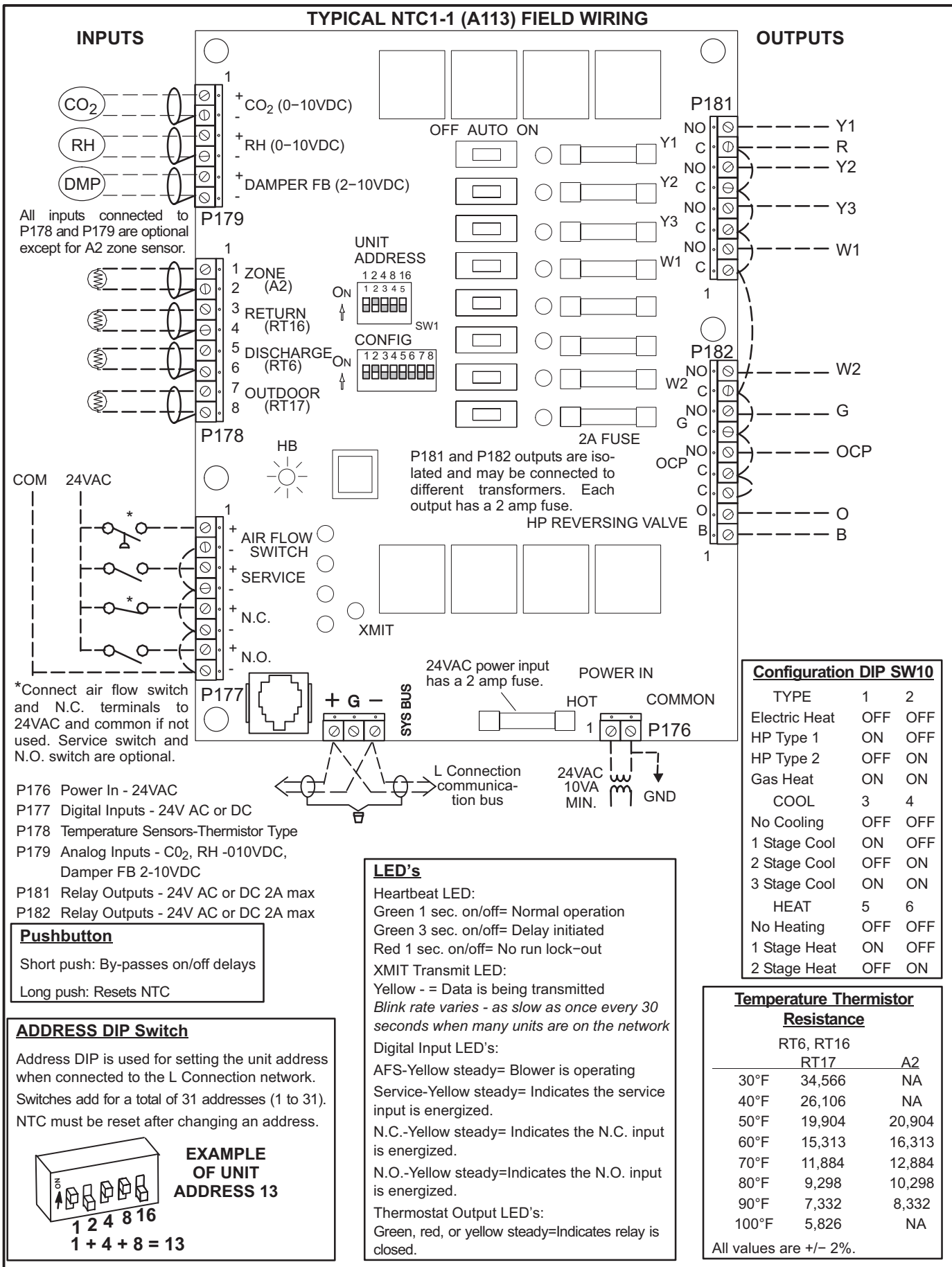

BUILDING CONTROLLER

COCTRL80AE1L (17M12)

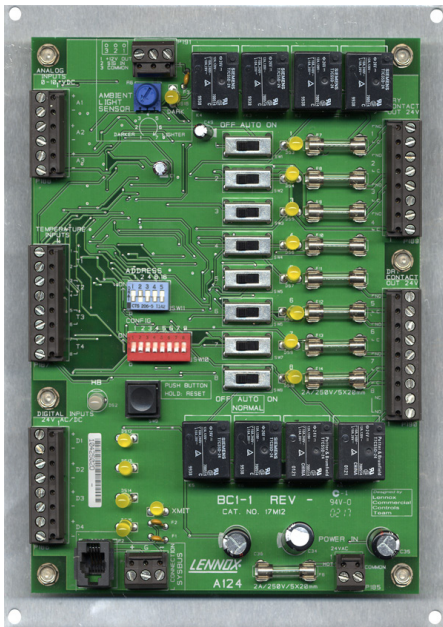

The **Building Controller** is used for controlling lights, vent hoods, exhaust fans, sprinklers and other devices based upon unit occupied operation or time schedule for the L Connection Network building automation system. It also allows many other interactions between the building and the HVAC equipment such as load shedding, wake up/shut down building switch and overrides based on temperatures and/or analog inputs. The Building Controller requires the Network Control Panel for system control.

Main Features of the Building Controller

- Eight dry contact outputs with LED indicator.
- Four temperature sensor inputs.
- Three analog inputs.
- Four digital inputs with LED indicator.
- Digital inputs may be used to override outputs on or off.
- Temperature and/or analog inputs may be used to override outputs on and off.
- Temperature and/or analog inputs may be used to issue user selected alarms.
- The occupied status of selected HVAC unit may be used to override outputs on or off.
- Digital inputs may be used to instruct selected HVAC units to operate on override setpoints
- Digital inputs may be used to instruct selected HVAC units to go to standby (off). • Digital inputs may be used to instruct selected HVAC units to shift setpoints.
- Each output has a manual “on/auto/off” switch.
- Input for optional Ambient Light Sensor C0SNSR60AE1- (**34M67**) used to automatically control lighting based on the amount of outside light.
- Multiple Building Controllers may be used on L Connection Network with the Network Control Panel
- Optional weatherproof NEMA 4 enclosure C0MISC10AE1-(**17M11**) and NEMA 1 enclosure C0MISC13AE1- (**34M23**) are available.

SPECIFICATIONS - BUILDING CONTROLLER

Network Control Panel Compatibility	Version 1.13 or higher
Unit Controller PC Software Compatibility	Version 2.03 or higher
Network Control Panel PC Software Compatibility	Version 2.03 or higher
Device Commissioning	Auto-poll (real plug and play)
Operating Environment	Temperature: -40°F to 155°F Humidity: 10% - 95% RH, Non- Condensing
Power Requirements	24VAC, +/- 25%, 50/60Hz, 2VA Class 2 transformer required
Indicator LEDs	1 - Heartbeat 1 - Bus transmit 1 - Each for all 4 digital inputs 1 - Each for all 8 digital outputs
Memory Type	Re-programmable Flash
Dimensions	Height: 8-1/2 in. Width: 6-1/2 in. Depth: 1-1/2 in.
Weight	1.10 lbs.
Electronic Configure To Order Parameters	87
Alarm Codes	29
Alarm Codes Stored	84
INPUTS / OUTPUTS	
Bus Port:	Lennox SysBus, EIA-485, 9600 baud (Field wiring terminal block and phone jack). Note: May connect to ZoneBus if under Zone Link.
Digital Outputs	8 relay contact outputs rated at 24V, 2 amp. Each one is fused and has a manual switch option for on, off or auto. Each output has LED indicator.
Digital Inputs	4 Digital inputs rated for 24VAC or DC. Each has LED indicator.
Analog Inputs	4 Analog inputs (0-10VDC). Compatible with Remote Humidity Sensor Kit C0SNSR31AE1- (17M50) and Duct Mount RH Sensor C0SNSR30AE1- (76M31). Also compatible with CO ₂ Sensors C0SNSR50AE1L (77M39), C0SNSR52AE1L (87N53), C0SNSR51AE1L (87N52), C0SNSR53AE1L (87N54).
Temperature Inputs	4 Temperature inputs (-30°F to 140°F). Compatible with Outdoor Temperature Sensor C0SNSR02AE1- (59M05), Duct Temperature Sensor C0SNDC04AE1- (99K64), Wall Mount Temperature Sensor C0SNZN03AE1- (59M04) and Temperature Sensor Probe C0SNSR05AE1- (14K92)
Light Sensor Input	1 Light Sensor input (0-10VDC). Compatible with Ambient Light Sensor C0SNSR60AE1- (34M67)
Cable Type	<p>SysBus - Lennox yellow COMM cable: C0MISC00AE1- (27M19) (500 ft. box), C0MISC04AE1- (94L63) (1000 ft. box), C0MISC01AE1- (68M25) (2500 ft. roll)</p> <p>ZoneBus - Lennox purple COMM cable: C0MISC05AE1- (23W99) (500 ft. box) C0MISC06AE1- (24W00) (1000 ft. box) C0MISC07AE1- (24W01) (2500 ft. roll)</p> <p>24VAC Power - 2 Conductor thermostat 22 AWG min. (wire gauge depends on distance from transformer) Digital Outputs - Thermostat cable 22 AWG min. (wire gauge depends on distance) Digital Inputs - Thermostat cable 22 AWG min. (wire gauge depends on distance). Analog Inputs - Lennox COMM cable Temperature Inputs - Lennox COMM cable Light Sensor Input - 3 Conductor thermostat cable 20 AWG min. (wire gauge depends on distance)</p>

NETWORK THERMOSTAT CONTROLLER - FIELD WIRING

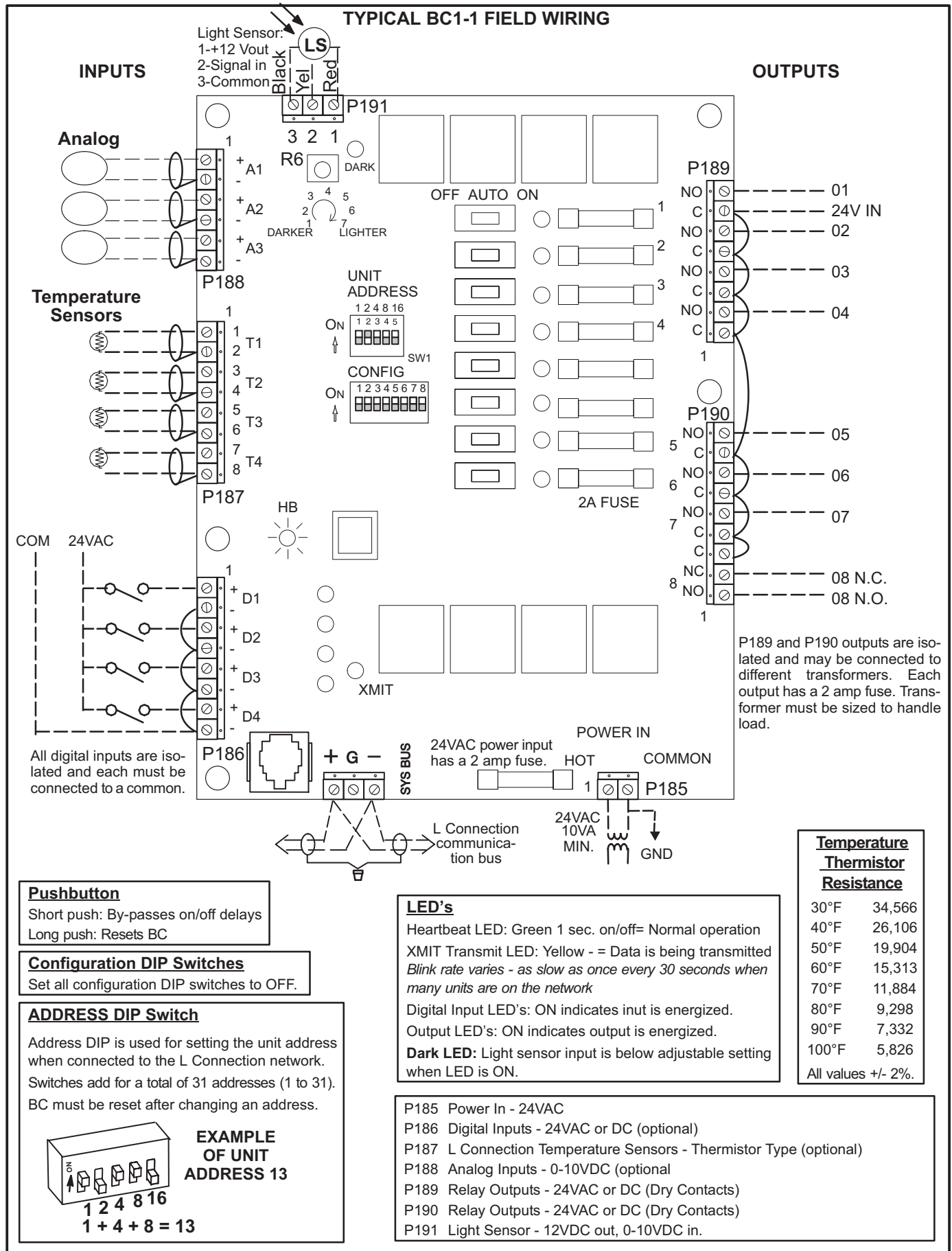

ZONE LINK

COCTRL11AE1L (11W27)



The **Zone Link** has two important functions. It controls the unit for zoning applications based on the demands of up to 31 zones and it also can be used as a network expander, which expands the L Connection Network up to 93 units on one Network Control Panel.

The Zone Link has a heartbeat LED and transmit LEDs on both communication ports for quick operation indication. It has two air balance modes that are set by a DIP switch that makes zoning air balance simple. Most applications will only require wiring to the Zone Link communication ports, but it also has 2 multi-functional digital inputs and 2 multi-functional outputs. The Zone Link is designed so that it can be mounted either inside a rooftop unit or inside the conditioned space. Power is provided from an external 24VAC transformer.

Main Features of the Zone Link

- Automatically self configures for either zoning mode or single zone expander mode.
- 181 optional control parameters (ECTOs).
 - Capable of controlling up to 31 zones/unit. Variable Air Volume Bypass (VAV) units.
 - Constant Air Volume Bypass units (CAVB) w/ bypass damper.
- Capable of adding up to 36 additional devices to network in bus expander mode.
- May be mounted in rooftop unit or in mechanical / electrical room of building.
- Built-in zoning air balance test mode.
- Two multi-functional 24VAC digital inputs.
 - Time Clock Option.
 - Global Smoke Alarm for all units under Zone Link
 - Purge (Zoning only).
 - Global shutdown (Zoning only).
- Two multi-functional digital (relay) outputs based on one of following conditions when used for zoning:
 - CO₂ above setpoint.
 - RH above setpoint.
 - RH below setpoint.
 - Unit lockout condition.
 - Unit in occupied mode.
- Three options for zoning demand control ventilation
 - Maximum occupied zone.
 - Average of all occupied zones.
 - Average of all zones.
- Three zoning morning ventilation modes
 1. Air Mix
 2. Fresh Air
 3. Purge
- LED indicators for both COM ports.
- LED for Heartbeat.
- Field upgradeable flash memory.
- Screw terminals for field wiring.
- Off-white plastic enclosure.
- Bracket for RTU mounting included.

SYSTEM COMPONENTS - ZONING

ZONE LINK (continued)

Sequence of Operation

Multiple Zones (Zone Link Zoning Mode)

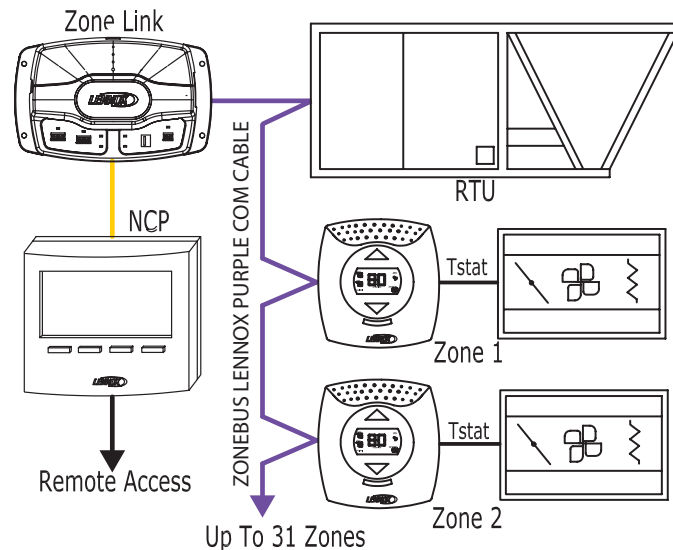

COM - Lennox COM cable.
Tstat - 2 conductor for damper only,
5 conductor for fan powered w/heat.

Single Zone (Zone Link Network Expander Mode)

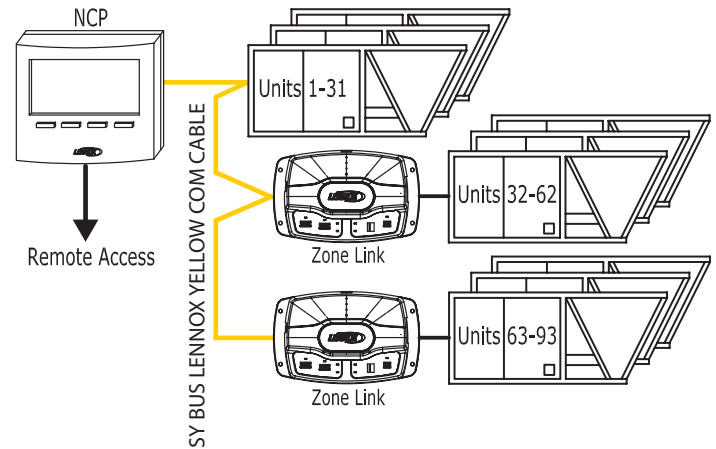

All cables shown are Lennox COM cable.
24VAC power wiring not shown.

After power up, the Zone Link begins automatically polling from address 1 to 31 and searching for units (devices). As soon as a unit controller (Prodigy® Unit Controller or Network Thermostat Controller) replies, the Zone Link checks the unit controller's system mode. If the system mode is set to Remote Demand Mode, the Zone Link knows it's a zoning application. Next, the Zone Link polls for Comfort Sensor-Zoning units. Now the Zone Link knows the application is zoning and how many zones are in use.

If a Network Control Panel is connected to the network, the setpoints for each zone are sent from the Panel. If the Zone Link is setup in the time clock mode, the built-in default setpoints in the Zone Link will be sent to each Comfort Sensor-Zoning.

Each Comfort Sensor-Zoning generates a vote for heating, cooling or no vote. The Zone Link adds up the votes of all zones, considering the zone weights and zone wait time of each zone and sends the appropriate heat/cool demand to the unit controller (Prodigy® Unit Controller or Network Thermostat Controller). The demand is maintained as long as the voting result maintains the majority or the maximum changeover time is reached.

In single zone operation, the Zone Link powers up and begins automatically polling addresses 1 to 31, searching for units (devices). As soon as a unit controller (Prodigy® Unit Controller or Network Thermostat Controller) replies, the Zone Link checks the unit controller's system mode. If the system mode is **anything except** Remote Demand Mode, the Zone Link knows its application is not for zoning, but for single zone operation. Next, the Zone Link polls for a Comfort Sensor with the same address as the Prodigy® Unit Controller or Network Thermostat Controller. If found, that Comfort Sensor is assigned to that particular unit. The Zone Link repeats this polling process until all units (devices) are found. The Zone Link can support up to 31 units without Comfort Sensors or 16 units paired with Comfort Sensors.

If a Network Control Panel is connected to the network, the setpoints for each zone are sent from the Panel. If the Zone Link is setup in the time clock mode, the built-in default setpoints in the Zone Link will be sent to each Comfort Sensor-Zoning.

There is no voting with single zone operation. The setpoints of the Comfort Sensor match the unit controller (Prodigy® Unit Controller or Network Thermostat Controller) and Network Control Panel (or time clock).

SPECIFICATIONS - ZONE LINK

Unit Controller Compatibility	Zoning Applications Prodigy® Unit Controller - All versions Network Thermostat Controller - Version 1.10 or higher Bus Expander Applications Prodigy® Unit Controller - All versions Network Thermostat Controller - All versions Building Controller - All versions
Network Control Panel Compatibility	All Applications
Unit Controller PC Software Compatibility	Version 2.08 or higher
Network Control Panel PC Software Compatibility	Version 2.08 or higher
Device Commissioning	Auto-poll (real plug and play)
Operating Environment	Temperature: -40°F to 155°F Humidity: 10% - 95% RH, Non- Condensing
Memory Type	Re-programmable Flash
Electronic Configure To Order Parameters	181
Power Requirements	24VAC (+/-25%), 50/60Hz, 2VA Class 2 transformer required
Indicator LEDs	1 - Heartbeat 1 - SysBus Transmit 1 - ZoneBus Receive 1 - Each for 2 digital inputs 1 - Each for 2 digital outputs
Dimensions	Height: 5 in. Width: 8 in. Depth: 1-3/4 in.
Weight	0.46 lbs.
Enclosure	High impact ABS off-white plastic case.
INPUTS / OUTPUTS	
Bus Port	Lennox SysBus, EIA-485, 9600 baud (Field wiring terminal block and phone jack located on side of control) Lennox ZoneBus, EIA-485, 9600 baud
Digital Inputs 1 and 2 -	Multi-Functional - 24VAC inputs that can be configured based on one of the following operations: Time Clock, Purge (Zoning only), Shutdown (Zoning only), Global Smoke for units under Zone Link
Digital Outputs 1 and 2 -	Multi-Functional - Relay (2 Amps, 24VAC) outputs that can be configured based on one of the following conditions for zoning; CO ₂ above setpoint, RH above setpoint, RH below setpoint, Unit Lockout, Unit occupied
Cable Type	SysBus - Lennox yellow COMM cable: C0MISC00AE1- (27M19) (500 ft. box), C0MISC04AE1- (94L63) (1000 ft. box), C0MISC01AE1- (68M25) (2500 ft. roll) ZoneBus - Lennox purple COMM cable: C0MISC05AE1- (23W99) (500 ft. box) C0MISC06AE1- (24W00) (1000 ft. box) C0MISC07AE1- (24W01) (2500 ft. roll) 24VAC Power - 2 Conductor thermostat 22 AWG min. (wire gauge depends on distance from transformer) Multi-functional I/O - Thermostat cable 22 AWG min.

ZONE LINK - FIELD WIRING

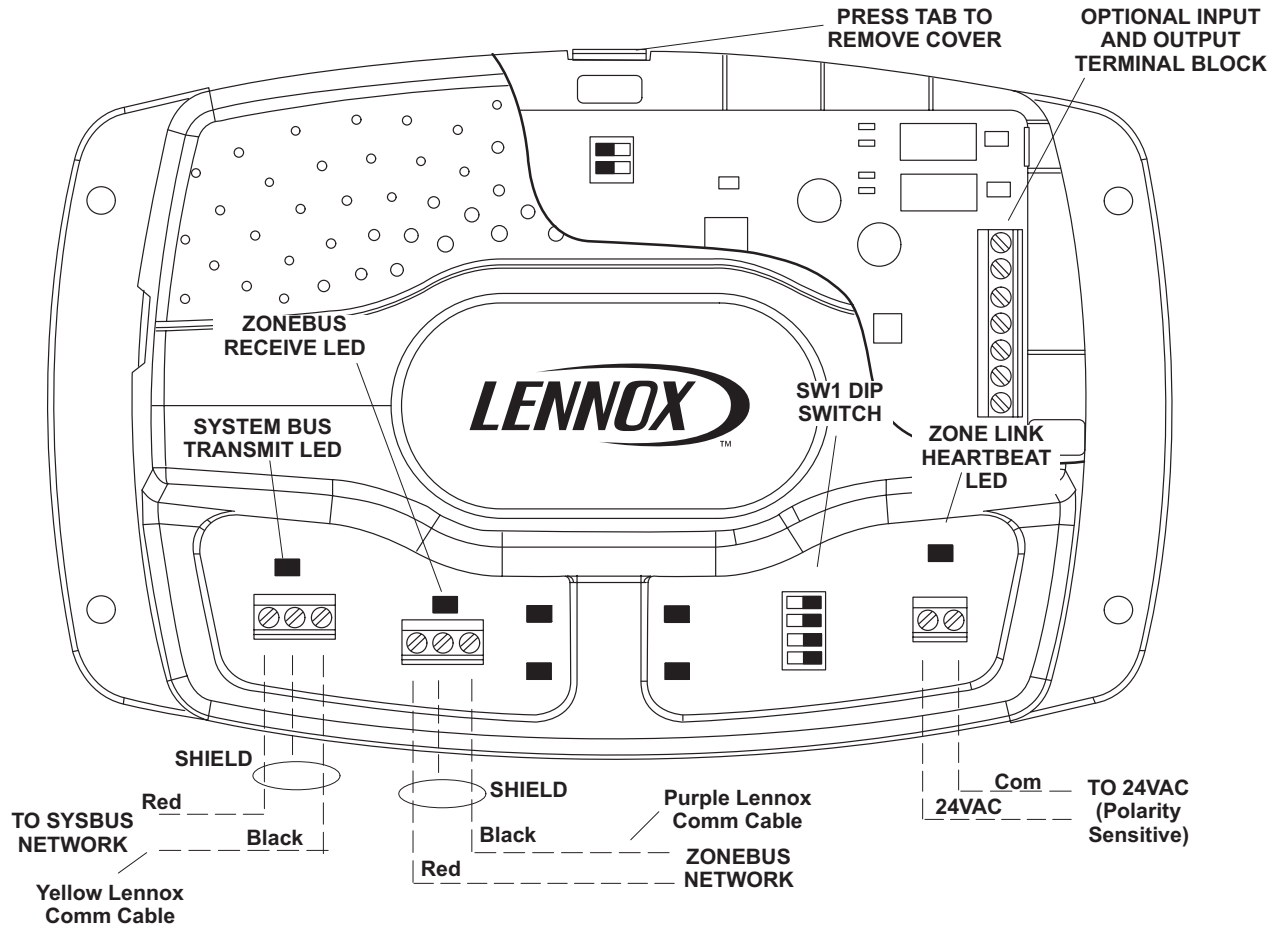

COMFORT SENSOR



The **Comfort Sensor** is a communicating, single zone unit room temperature sensor that is available with optional built-in relative humidity and CO₂ sensors. It is also available with LCD display with setpoint and fan control. Each model of the Comfort Sensor has an input for up to four additional optional remote room temperature sensors. These sensors may be used for applications that require remote temperature sensing or temperature averaging. In addition, each version also has an input for optional occupancy switch that could be used for controlling the occupied status of the unit as well as the occupied/unoccupied temperature setpoints. Each model can be used with the Network Control Panel for scheduling setpoints or in a stand-alone mode without the Network Control Panel. No setpoint scheduling is available when used in the stand-alone mode.

Main Features of the Comfort Sensor

- Single unit temperature setpoint control.
 - Works with the Network Control Panel.
 - Also works in stand-alone mode.
- Available with zone RH and/or zone CO₂ sensors.
- CO₂ self calibration system eliminates the need for manual calibration in most applications.
- Available with or without display and setpoint adjustment.
- Easy user interface on models with setpoint control.
- Field upgradeable flash memory.
- Display in degrees °F or °C.
- May use up to four additional averaging sensors (optional).
- May use remote sensor (optional).
- May use optional field provided occupancy sensor.
- Screw terminals for field wiring.
- Off-white plastic enclosure.
- 8 Electronic Configure-To-Order (ECTO) parameters.
- All models have after-hours override push-button.
- All models have convenient phone jack for configuration with L Connection Unit Controller PC software.

Models With Display and Setpoint Adjustment

- C0SNAJ02AE1L (**18W68**) - Temperature, Display, Setpoint/Fan Control, After-Hours Override Button
- C0SNMT10AE1L (**18W66**) - Temperature, Relative Humidity, Display, Setpoint/Fan Control, After-Hours Override Button
- C0SNMT20AE1L (**18W67**) - Temperature, CO₂, Display, Setpoint/Fan Control, After-Hours Override Button
- C0SNMT30AE1L (**18W65**) - Temperature, Relative Humidity, CO₂, Display, Setpoint/Fan Control, After-Hours Override Button

User Interface

Display/Setpoint Adjustable Models have a user interface, consisting of an LCD display and three push buttons.

Push button functions:

1. Adjusting zone temperature setpoints.
2. Changing zone occupied mode.
3. Resuming a scheduled program.
4. Viewing zone data, zone temperature (°F or °C), relative humidity (%), carbon dioxide level (PPM) and outdoor temperature (°F or °C).
5. Controlling unit blower.

All models have an after-hours override button on the right side.

COMFORT SENSOR (continued)

Display Options (Models With Display and Setpoint Adjustment)

The information display on the Comfort Sensor's main screen is configurable using Electronic Configure To Order (ECTO) parameters. The default configuration displays Indoor (zone) Temperature, Operation Status (HEAT or COOL), and Occupancy Status. The Indoor (zone) Temperature and Heating/Cooling Setpoints can be set to display in 0.5 degree increments (default is one degree).

Depending on the type of Comfort Sensor model used, various other data can be displayed on the main screen:

- **CO₂ Models** - Can be configured to display CO₂ or Outdoor Temperature (You can access the mode not displayed by holding down the select button, the display will alternate between each mode at one second intervals).
- **Relative Humidity (RH) Models** - May be configured to display Relative Humidity or Heating Setpoint. If Relative Humidity is displayed, pushing any button will display Heating Setpoint.
- **CO₂ and Relative Humidity (RH) Models** - Displays CO₂ or Outdoor Temperature (You can access the mode not displayed by holding down the select button, the display will alternate between each mode at one second intervals). This model can also be configured to display Relative Humidity or Heating Setpoint. If Relative Humidity is displayed, pushing any button will display Heating Setpoint.

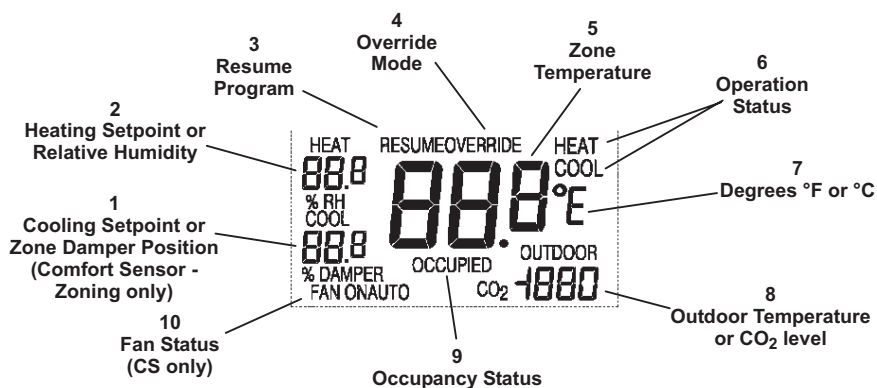

1. **Cooling Setpoint or Zone Damper Position** - When the ECTO is set to display the damper position, any button may be pushed to display the setpoints. Damper position is available for use with Comfort Sensor-Zoning sensors only.
2. **Heating Setpoint or Relative Humidity** - When the ECTO is set to display the relative humidity, any button may be pushed to display the setpoints. Comfort Sensor/Comfort Sensor-Zoning must be equipped with RH option to display RH.
3. **Resume Program** - Displayed when override mode is returning to a scheduled program.
4. **Override Mode** - Displayed when a scheduled program has been overridden. Also referred to as After-Hours Override.
5. **Zone Temperature**
6. **Operation Status** - Either HEAT or COOL will be displayed when the zone is operating in heating or cooling mode. The appropriate readout will blink if the zone is requesting either heating or cooling and the zone is not yet being serviced.
7. **Degrees °C or °F**
8. **Outdoor Temperature or CO₂** - CO₂ level shown in parts per million. The Comfort Sensor/Comfort Sensor-Zoning must be equipped with CO₂ option to display CO₂.
9. **Occupancy Status** - Displayed when the zone is in occupied mode. Nothing is displayed in this area during the unoccupied time period.
10. **Fan Status** - Comfort Sensor only. If enabled, the unit fan control status is displayed, either FAN ON (continuous) or FAN AUTO (cycles with heating or cooling operation).

Models Without Display or Setpoint Adjustment

- C0SNZN09AE1- (18W72) Temperature, After-Hours Override Button.
- C0SNMT11AE1- (18W69) Temperature, Relative Humidity, After-Hours Override Button.
- C0SNMT21AE1L (18W70) - Temperature, CO₂, After-Hours Override Button.
- C0SNMT31AE1L (18W71) - Temperature, Relative Humidity, CO₂, After-Hours Override Button.



COMFORT SENSOR (continued)

SEQUENCE OF OPERATION

Temperature Setpoint and Occupancy Operation with Network Control Panel

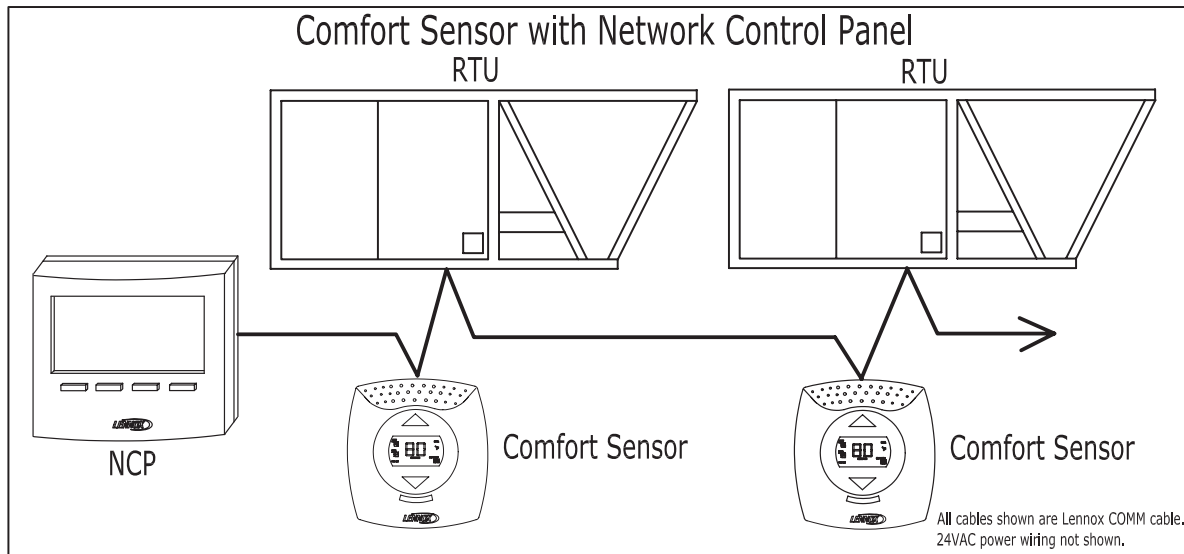

The Comfort Sensor operates to maintain the zone temperature setpoint. The heating and cooling setpoints originate from a Zone Link running in Time Clock mode, a Network Control Panel or the Comfort Sensor. In applications using the Network Control Panel operating in manual mode, a Comfort Sensor with display can fully adjust the setpoints between a minimum of 40°F and the maximum of 95°F.

The system maintains two sets of setpoints, Occupied and Unoccupied. If the zone is currently unoccupied, the zone may be overridden into the occupied state by:

1. Pressing the UP/DOWN buttons to change the current setpoints, in a display version of Comfort Sensor.
2. Pressing the OVERRIDE button on the side of the Comfort Sensor.
3. Applying an occupied signal to the Comfort Sensor Occupancy Input.
4. Changing the occupied state of the zone, at the Network Control Panel or using the Network Control Panel Software.

The Comfort Sensor with display can be used to override the current setpoints within a specified range. This range is set in an internal ECTO parameter. A setting of zero disables this feature. Pressing the UP or DOWN buttons will change the current (most-recently serviced) heating or cooling setpoint. Pressing the SELECT button will highlight the other heating or cooling setpoint, allowing adjustment of this setpoint. These override setpoints will be active for the time specified in the Override Timer ECTO parameter that is set in the Network Control Panel.

Pressing the side OVERRIDE button will initiate the override timer. The zone will go into the occupied state and use the override setpoints for the time set in the Override Timer ECTO parameter that is in the Network Control Panel.

The override operation may be disabled by setting the Network Control Panel override timer ECTO parameter to zero.

SYSTEM COMPONENTS - SENSORS

COMFORT SENSOR (CONTINUED)

SEQUENCE OF OPERATION

Temperature Setpoint and Occupancy Operation without Network Control Panel

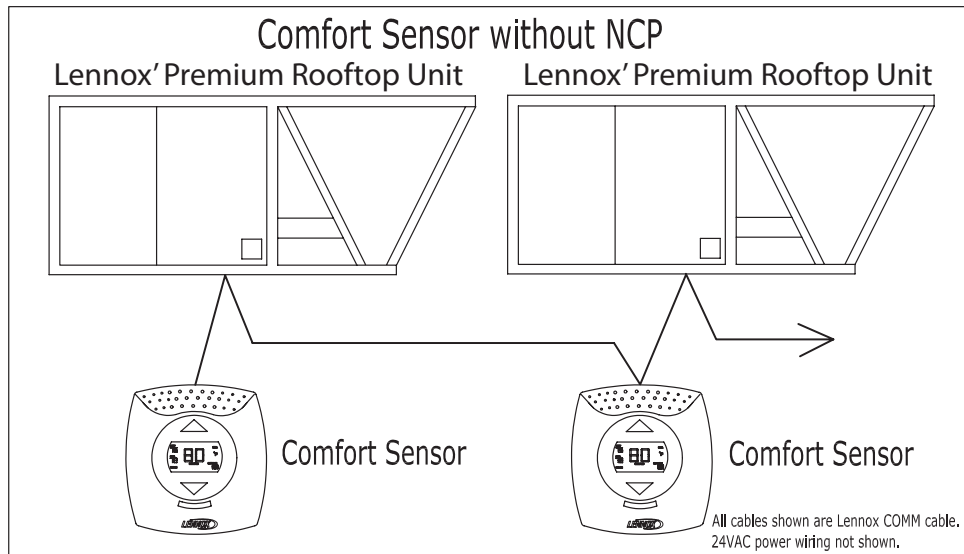

The Comfort Sensor operates to maintain the zone temperature setpoint. In applications without a Network Control Panel, the heating and cooling setpoints originate from the Prodigy® Unit Controller ECTO parameters. A Comfort Sensor model with display can be used to adjust the setpoints within its allowable range. The allowable range can be set from ± 0 to 10°F.

Relative Humidity Operation

The Comfort Sensor models with built-in RH sensor can be used to control Humiditrol™ units based on the RH setpoint and conditions stored in the Prodigy Unit Controller unit controller ECTO parameters. The Comfort Sensor with RH sensor option can also be used to control any premium Lennox rooftop unit configured in supermarket reheat mode, which uses gas heat for reheat. Like Humiditrol operation, the RH setpoint and conditions for supermarket reheat are stored in the Prodigy Unit Controller ECTO parameters.

CO₂ Operation

The Comfort Sensor models with built-in CO₂ sensor can be used to control Lennox' premium rooftop unit Demand Control Ventilation features based on CO₂ setpoints and conditions stored in the Prodigy Unit Controller ECTO parameter

SPECIFICATIONS - COMFORT SENSOR

Unit Controller Compatibility	Prodigy® Unit Controller - All versions Network Thermostat Controller - Version 1.10 or higher
Network Control Panel Compatibility	Version 2.00 or higher
Unit Controller PC Software Compatibility	Version 2.08 or higher
Network Control Panel PC Software Compatibility	Version 2.08 or higher
Device Commissioning	Auto-poll (real plug and play)
Operating Environment	Temperature: -0°F to 105°F Humidity: 10% - 95% RH, Non- Condensing
Memory Type	Re-programmable Flash
Electronic Configure To Order Parameters	8
Power Requirements	24VAC (+/-25%), 50/60Hz, 3VA Class 2 transformer required
Temperature Range	Temperature: -33°F to 99°F
Temperature Accuracy	+/- 0.4°F (May be field calibrated to +/- 0.25°F)
RH Range	10-95% RH
RH Accuracy	+/- 5% RH (May be field calibrated to +/-2%)
CO ₂ Range	0-2000 ppm
CO ₂ Accuracy	+/- 40 ppm + 3% or reading @ 25C CO ₂ sensor has built-in self calibration algorithm Unit Controller PC software can be used to turn the self calibration algorithm off, set elevation and to calibrate sensor if needed.
Temperature Setpoint Range	Temperature: -40°F to 95°F
Display Type (for models w/displays)	Liquid Crystal (LCD) with Green LED backlight
Dimensions	Height: 5 in. Width: 4-1/2 in. Depth: 1-3/8 in.
Weight	0.42 lbs.
Enclosure	High impact ABS off-white plastic case.
INPUTS / OUTPUTS	
Bus Port:	Lennox SysBus, EIA-485, 9600 baud (Field wiring terminal block and phone jack located on side of control). Note - May connect to ZoneBus if under Zone Link.
Remote Temperature Sensor Input	Up to four remote temperature sensors connected in parallel for averaging and remote monitoring. Compatible with Miniature Wall-Mount Zone Sensor C0SNZN08AE1- (94L61) and Wall-Mount Zone Sensor with Adjustable Zone Temperature C0SNAJ01AE1- (56L80).
Occupancy Sensor Input	24VAC input (On for occupied)
Cable Type	SysBus - Lennox yellow COMM cable: COMISC00AE1- (27M19) (500 ft. box), COMISC04AE1- (94L63) (1000 ft. box), COMISC01AE1- (68M25) (2500 ft. roll) ZoneBus - Lennox purple COMM cable: COMISC05AE1- (23W99) (500 ft. box) COMISC06AE1- (24W00) (1000 ft. box) COMISC07AE1- (24W01) (2500 ft. roll) 24VAC Power - Two Conductor thermostat 22 AWG min. (wire gauge depends on distance from transformer) Remote Temperature Sensor - Two Conductor thermostat cable 22 AWG min. (wire gauge depends on distance) Occupancy Sensor - Two Conductor thermostat cable 22 AWG min. (wire gauge depends on distance).

COMFORT SENSOR - FIELD WIRING

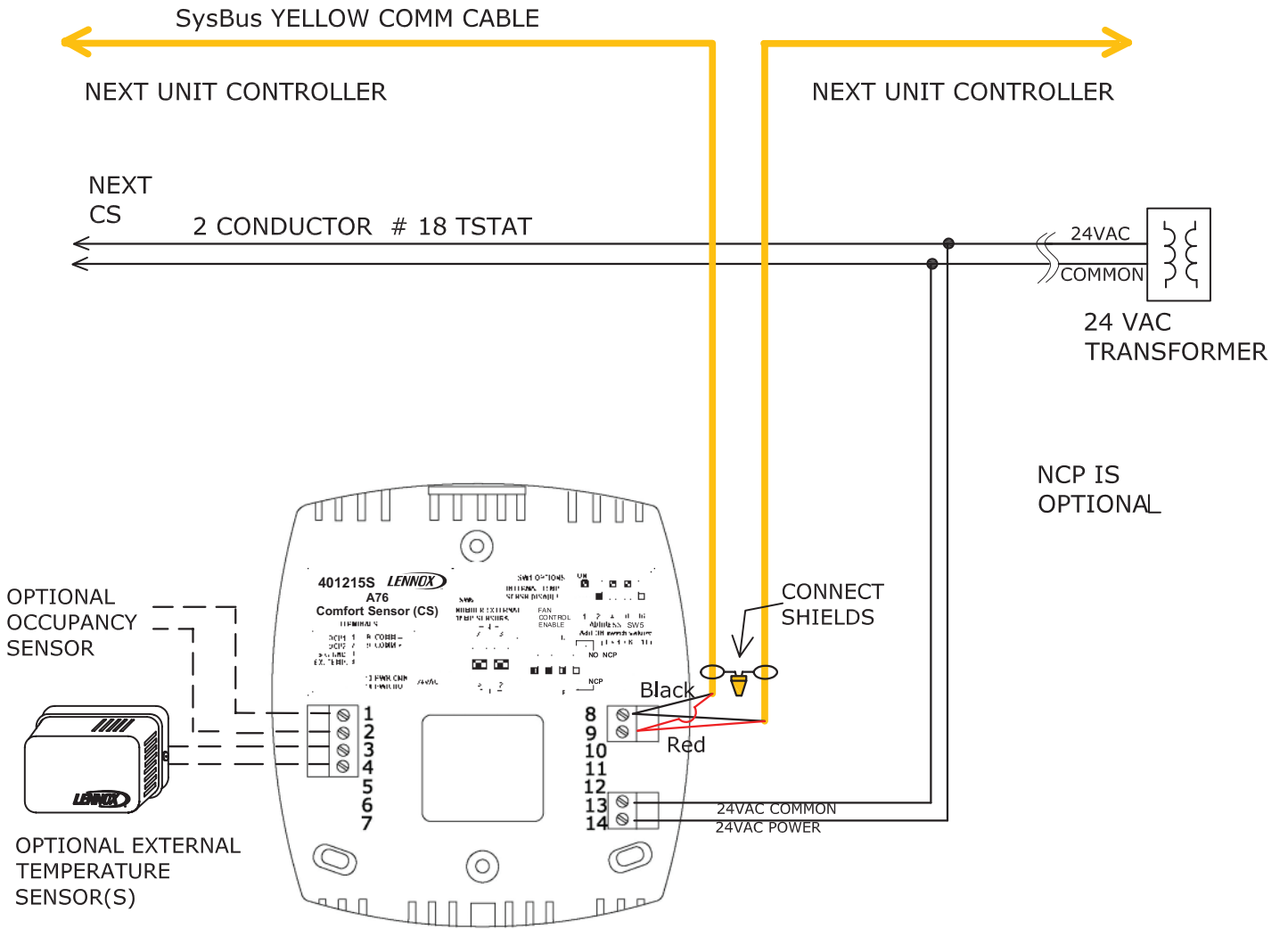

COMFORT SENSOR-ZONING

The **Comfort Sensor-Zoning** is a communicating zone temperature sensor and controller that is available with a variety of features including built-in relative humidity and CO₂ sensors. It is also available with or without LCD display and setpoint adjustment. Each model of the Comfort Sensor-Zoning also has outputs necessary to control either a zone damper or a fan powered VAV terminal with electric heat.



Each model has an input for up to four additional optional remote room temperature sensors. These sensors may be used for applications that require remote temperature or temperature averaging. In addition, each model has an input for an optional occupancy switch that can be used for controlling the occupied status of the zone as well as the occupied/unoccupied temperature setpoints.

The Comfort Sensor-Zoning must be used in conjunction with a Zone Link for controlling the unit in zoning applications. In addition, the Network Control Panel can be used for scheduling up to six setpoint changes per day for each zone. A time clock may be used for controlling the occupied status of the zones as well as the occupied/unoccupied temperature setpoints.

Main Features of the Comfort Sensor-Zoning

- Zone sensor and zoning controller for damper, fan and zone heat.
- Compatible with Damper Actuator C0MISC21AE1L (12W98).
- Available with zone RH and/or zone CO₂ sensors
- Available with or without display. Units with display have setpoint control.
- Easy user interface on models with setpoint control
- Field upgradeable flash memory.
- Display in degrees °F or °C.
- May use up to four additional averaging sensors (optional).
- May use remote sensor (optional).
- May use optional field provided occupancy sensor.
- 28 Electronic Configure To Order (ECTO) parameters
- Screw terminals for field wiring.
- Off-white plastic enclosure.
- All models have after-hours override push-button.
- All models have convenient phone jack for configuration with L Connection Unit Controller PC software.

Models With Display and Setpoint Adjustment

- C0SNCT01AE1L (18W58) - Temperature, Display, Setpoint/Fan Control, After-Hours Override Button, Zone Damper, Fan and Heat Control.
- C0SNCT10AE1L (18W56) - Temperature, Relative Humidity, Display, Setpoint/Fan Control, After-Hours Override Button, Zone Damper, Fan and Heat Control.
- C0SNCT20AE1L (18W57) - Temperature, CO₂, Display, Setpoint/Fan Control, After-Hours Override Button, Zone Damper, Fan and Heat Control.
- C0SNCT30AE1L (18W55) - Temperature, Relative Humidity, CO₂, Display, Setpoint/Fan Control, After-Hours Override Button, Zone Damper, Fan and Heat Control.

Models Without Display or Setpoint Adjustment



- C0SNCT00AE1L (18W59) - Temperature, After-Hours Override Button, Zone Damper, Fan and Heat Control.
- C0SNCT11AE1L (18W60) - Temperature, Relative Humidity, After-Hours Override Button, Zone Damper, Fan and Heat Control.
- C0SNCT21AE1L (18W61) - Temperature, CO₂, After-Hours Override Button, Zone Damper, Fan and Heat Control.
- C0SNCT31AE1L (18W62) - Temperature, Relative Humidity, CO₂, After-Hours Override Button, Zone Damper, Fan and Heat Control.

COMFORT SENSOR-ZONING (continued)

SEQUENCE OF OPERATION

Setpoint and Occupancy Operation

The Comfort Sensor-Zoning operates to maintain the zone temperature setpoint. The heating and cooling setpoints originate from the Zone Link operating in time clock mode, or a Network Control Panel running a time schedule program. In a Network Control Panel application operating in manual mode, a Comfort Sensor-Zoning with a display can be used to fully adjust the setpoints between a minimum of 40°F and the maximum of 95°F.

The system maintains two sets of setpoints, Occupied and Unoccupied.

If the zone is currently unoccupied, the zone may be overridden into the occupied state by:

1. Pressing the UP/DOWN buttons to change the current setpoints, in a display version of the Comfort Sensor-Zoning
2. Pressing the OVERRIDE button on the side of the Comfort Sensor-Zoning.
3. Applying an occupied signal to the Comfort Sensor-Zoning occupancy input.
4. Changing the occupied state of the zone, at the Network Control Panel or using the Network Control Panel Software.

The Comfort Sensor-Zoning with display can be used to override current setpoints within a specified range. This range is set using an ECTO parameter. A setting of zero disables this feature. Pressing the UP or DOWN buttons will change the current (most-recently serviced) heating or cooling setpoint. Pressing the SELECT button will highlight the other setpoint, allowing the adjustment of this setpoint. These override setpoints will be active for the time specified in the Override Timer ECTO parameter that is set in the Network Control Panel.

Pressing the OVERRIDE button on the right side of the case will initiate the override timer. The zone will go into the occupied state, and use the override setpoints for the time set in the Override Timer ECTO parameter that is in the Zone Link.

The override operation may be disabled by setting the Zone Link Override Timer ECTO parameter to zero.

The application of 24 volts AC to the occupancy sensor input of the Comfort Sensor-Zoning will force the zone into the occupied state. The Comfort Sensor-Zoning will operate with occupied setpoints as long as this signal is applied.

Heating and Cooling Demands and Zone Damper Operation

The Comfort Sensor-Zoning will generate a cooling demand if the zone temperature is a specified amount above the cooling setpoint. This amount is set in the ECTO parameter, COOLING DIFFERENTIAL 1. The default is 0.5 °F. The cooling demand will remain until the zone temperature drops below the temperature defined by: COOLING SETPOINT plus COOLING DIFFERENTIAL 1, minus ECTO parameter COOLING DEADBAND (default 1.5°F).

A high demand cooling state is entered if the zone temperature exceeds the setpoint plus ECTO parameter, COOLING DIFFERENTIAL 2. This higher demand state will, by default, double the weight of the cooling demand to the Zone Link in determining the operating state of the HVAC unit.

Similarly, the Comfort Sensor -Zoning will generate a heating demand if the zone temperature is a specified amount below the heating setpoint. This amount is set in the ECTO parameter, HEATING DIFFERENTIAL 1. The default is 0.5 °F. The heating demand will remain until the zone temperature rises above the temperature defined by: HEATING SETPOINT minus HEATING DIFFERENTIAL 1, plus ECTO parameter HEATING DEADBAND (default 1.5°F).

A high demand heating state is entered if the zone temperature is lower than the setpoint minus ECTO parameter, HEATING DIFFERENTIAL 2. This higher demand state will, by default, double the weight of the heating demand to the Zone Link in determining the operating state of the HVAC unit.

If the zone is in a heating or cooling demand and the supply air is not suitable for this demand, the zone damper will be at its minimum position if the zone is occupied, or closed if the zone is unoccupied.

If there is no demand but the supply air temperature is above the cooling setpoint or below the heating setpoint, the zone damper will be at its minimum position if the zone is occupied, or closed if the zone is unoccupied.

If the supply air is suitable for the demand, the Comfort Sensor-Zoning will modulate the damper according to a proportional-integral (PI) control algorithm, the zone temperature and the temperature setpoint. There is an ECTO parameter for the proportional constant and for the integral constant for each of the heating and cooling demands.

If the zone temperature is between the heating and cooling setpoints, the supply air is between the setpoints and the zone is occupied, the damper will open to the ECTO parameter ventilation position.

COMFORT SENSOR-ZONING (continued)

SEQUENCE OF OPERATION (continued)

Zone Terminal Box Operation

The Comfort Sensor-Zoning can optionally control a zone terminal box. It has one relay output for controlling either a series or parallel fan, and one relay output to control either electric reheat, auxiliary heat, or peripheral heat.

With a zone terminal box, the zone has the opportunity for local heat operation, while the HVAC unit is either idle or is in cooling.

A series fan pulls air from both the supply air duct and the return air plenum. It is on whenever the zone is occupied, or is in either heating, local heating, cooling or ventilation states.

A parallel fan pulls air from the return air plenum. It is on only during the local heating state.

Electric reheat is on with either a low or high demand, during a local heat state. It requires air flow from either the terminal box fan, or the HVAC unit blower with the zone damper set to the ventilation position.

Auxiliary heat is on with a high demand, during a local heat state. It requires either the terminal box fan or the HVAC unit blower to be on.

Peripheral heat is on with any heat demand - either a local heat state or when the HVAC unit is heating.

Zone High CO₂ Operation

The Comfort Sensor-Zoning may be configured to open the zone damper to the ventilation position and turn on the zone terminal box fan if the zone carbon dioxide level exceeds a specified CO₂ setpoint. The zone will stay in this state until the CO₂ level is 100 ppm lower than the CO₂ setpoint.

The Comfort Sensor-Zoning default setting for this feature is disabled.

When the Comfort Sensor-Zoning is in the High CO₂ state, the zone quits voting to determine the demands to the HVAC unit. The zone temperature is still used in determining the discharge air temperature reset, if enabled.

The Comfort Sensor-Zoning CO₂ setpoint must be set higher than the HVAC unit IAQ setpoint.

Other Modes of Operation

Smoke Mode - The Comfort Sensor-Zoning monitors the status of the HVAC unit. If the HVAC unit is in smoke mode, then the Comfort Sensor-Zoning will also go to smoke mode. If the unit's blower is running in smoke mode, Comfort Sensor-Zoning will turn on its series fan and open the zone damper to ventilation position. Otherwise the Comfort Sensor-Zoning will close the zone damper and turn off the terminal box fan.

The zone damper and terminal box fan may be controlled remotely by the Zone Link or through the Unit Controller Software when the system is in a special mode such as air balance or building air purge.

SPECIFICATIONS - COMFORT SENSOR-ZONING

Unit Controller Compatibility	Prodigy® Unit Controller - All versions Network Thermostat Controller - Version 1.10 or higher
Network Control Panel Compatibility	Version 2.00 or higher
Zone Link Compatibility	Version 1.00 or higher
Unit Controller PC Software Compatibility	Version 2.08 or higher
Network Control Panel PC Software Compatibility	Version 2.08 or higher
Device Commissioning	Auto-poll (real plug and play)
Operating Environment	Temperature: -0°F to 105°F Humidity: 10% - 95% RH, Non- Condensing
Memory Type	Re-programmable Flash
Electronic Configure To Order Parameters	28
Power Requirements	24VAC (+/-25%), 50/60Hz, 3VA Class 2 transformer required
Temperature Range	Temperature: -34°F to 99°F
Temperature Accuracy	+/- 0.4°F (May be field calibrated to +/- 0.25°F)
RH Range	5-95% RH
RH Accuracy	+/- 5% RH (May be field calibrated to +/-2%)
CO ₂ Range	0-2000 ppm
CO ₂ Accuracy	+/- 40 ppm + 3% of reading @ 77°F CO ₂ sensor has built-in self calibration algorithm Unit Controller PC software can be used to turn the self calibration algorithm off, set elevation and to calibrate sensor if needed.
Temperature Setpoint Range	Temperature: -40°F to 95°F
Display Type (for models w/displays)	Liquid Crystal (LCD) with Green LED backlight
Dimensions	Height: 5 in. Width: 1/2 in. Depth: 1-3/8 in.
Weight	0.44 lbs.
Enclosure	High impact ABS off-white plastic case.
INPUTS / OUTPUTS	
Bus Port	Lennox SysBus, EIA-485, 9600 baud
Remote Temperature Sensor Input	Up to four remote temperature sensors connected in parallel for averaging with the internal sensor or for remote monitoring. Compatible with Miniature Wall-Mount Zone Sensor C0SNZN08AE1- (94L61) and Wall-Mount Zone Sensor with Adjustable Zone Temperature C0SNAJ01AE1- (56L80).
Occupancy Sensor Input	24VAC input (On for occupied)
Zone Damper Output	2-10VDC (modulating damper)
Zone Damper Feedback Input	2-10VDC input - not used on Damper Actuator C0MISC21AE1L (12W98)
Zone Fan Output	Relay (24VAC, 1 Amp)
Zone Heat Output	Relay (24VAC, 1 Amp)
Cable Type	ZoneBus - Lennox purple COMM cable: C0MISC05AE1- (23W99) (500 ft. box) C0MISC06AE1- (24W00) (1000 ft. box) C0MISC07AE1- (24W01) (2500 ft. roll) 24VAC Power - Two Conductor thermostat 22 AWG min. (wire gauge depends on distance from transformer) Remote Temperature Sensor - Two Conductor thermostat cable 22 AWG min. (wire gauge depends on distance) Occupancy Sensor - Two Conductor thermostat cable 22 AWG min. (wire gauge depends on distance) Zone Damper Output - Thermostat cable 22 AWG min. (wire gauge depends on distance) Zone Damper Feedback - Thermostat cable 22 AWG min. (wire gauge depends on distance) Zone Fan Output - Thermostat cable 20 AWG min. (wire gauge depends on distance) Zone Heat Output - Thermostat cable 20 AWG min. (wire gauge depends on distance)

COMFORT SENSOR - FIELD WIRING

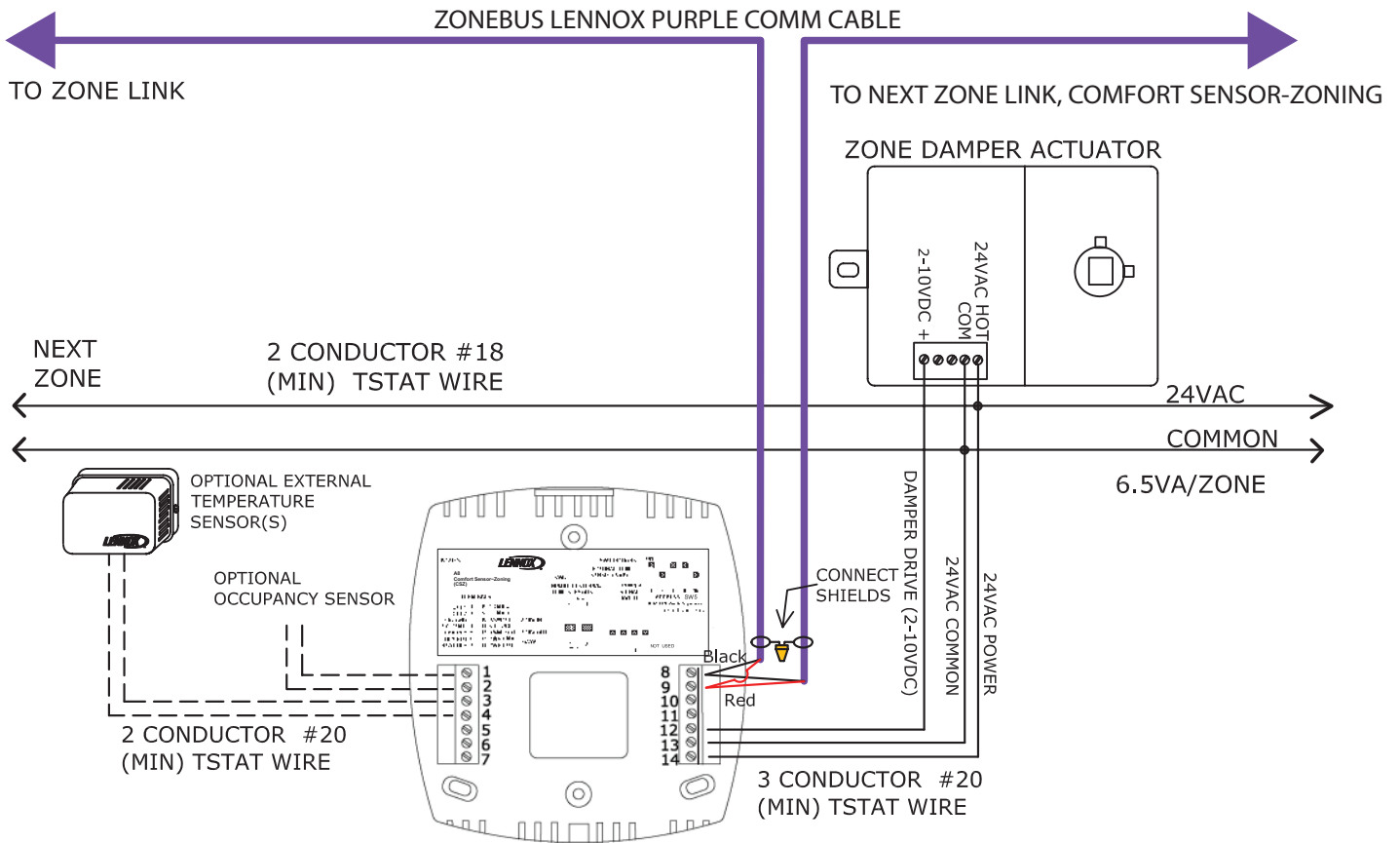

SYSTEM COMPONENTS - SENSORS

ZONE SENSOR - WALL-MOUNT (NON-COMMUNICATING)

C0SNAJ01AE1- (56L80) AND C0SNZN07AE1- (94L60)



Two-wire non-communicating wall-mounted zone sensors. Each sensor is designed to fit a single gang electrical handy box. The C0SNAJ01AE1- has a sensor offset slide that allows for easy temperature adjustment. Each sensor also has SysBus/ZoneBus phone jack that may be connected to the network. The bus connection is not required for sensor operation.

Main Features of Non-Communicating Zone Sensors

- Terminal blocks for wiring connections.
- Simple two-wire sensor connection.
- After-hours override button.
- Off-white plastic enclosure.
- C0SNAJ01AE1- features warmer/cooler zone adjustment on bottom of sensor
- Provides +/- zone temperature offset control.
- Adjustment amount is field selected using a DIP switch located under the cover.
 - Options include:
 - +/- 1°F.
 - +/- 4°F.
 - Non-adjustable.
- Sensor has a phone jack that may be used for connecting a PC converter to a PC with L Connection Network software.
- Sensor does not require a connection to the L Connection Network to function.
- C0SNZN07AE1- does not have the warmer/cooler temperature adjustment feature.

SPECIFICATIONS - ZONE SENSOR (NON-COMMUNICATING)

Unit Controller Compatibility	Prodigy® Unit Controller, Network Thermostat Controller
Temperature Range	40°F to 95°F
Offset Adjustment Range (C0SNAJ01AE1- only)	DIP switch options (located under cover) 1. No adjustment 2. +/- 1°F 3. +/- 4°F
Accuracy	+/-0.36°F
Stability	+/-0.23°F
Interchangeability	+/-0.36°F
Sensor Type	NTC thermistor , 11K @76°F w/offset Pot
Enclosure	High impact ABS off-white plastic case
Dimensions	Height: 4-1/2 in. Width: 2-3/4 in. Depth: 1-1/8 in.
Weight	0.0625 lbs.
INPUTS / OUTPUTS	
Sensor	Two-wire (not polarity sensitive)
SysBus/ZoneBus	Optional (polarity sensitive)
Cable Type	Optional SysBus - Lennox yellow COMM cable: C0MISC00AE1- (27M19) (500 ft. box), C0MISC04AE1- (94L63) (1000 ft. box), C0MISC01AE1- (68M25) (2500 ft. roll)

SYSTEM COMPONENTS - SENSORS

MINIATURE ZONE SENSOR - WALL-MOUNT (NON-COMMUNICATING)

C0SNZN08AE1- (94L61) AND C0SNZN03AE1- (59M04)



Small non-communicating wall-mount zone sensors.

- C0SNZN08AE1- Non-communicating only.
- C0SNZN03AE1- Non-communicating for use with Building Controller.

Main Features of Non-Communicating Zone Sensors

- Small size.
- Terminal block for wiring connections.
- Off-white plastic enclosure.
- C0SNZN03AE1- for use with the Building Controller.

SPECIFICATIONS - MINIATURE ZONE SENSOR (NON-COMMUNICATING)

Unit Controller Compatibility	C0SNZN08AE1- Prodigy® Unit Controller, Network Thermostat Controller C0SNZN03AE1- Building Controller
Temperature Range	40°F to 95°F
Accuracy	+/-0.36°F
Stability	+/-0.23°F
Interchangeability	+/-0.36°F
Sensor Type	C0SNZN08AE1- NTC thermistor, 11K @76°F C0SNZN03AE1- NTC thermistor, 10K @76°F
Enclosure	High impact ABS off-white plastic case with aluminum base
Dimensions	Height: 1-1/2 in. Width: 2 in. Depth: 1 in.
Weight	0.06 lbs.
Cable Type	Sensor - Lennox yellow COMM cable: COMISC00AE1- (27M19) (500 ft. box), COMISC04AE1- (94L63) (1000 ft. box), COMISC01AE1- (68M25) (2500 ft. roll)

SYSTEM COMPONENTS - SENSORS

RETURN AIR DUCT MOUNT ZONE SENSOR (NON-COMMUNICATING)

C0SND02AE1- (56L81)

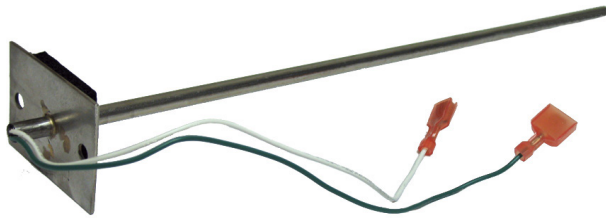

Duct mounted non-communicating zone sensor designed for applications where a wall mounted sensor is not practical. The sensor wires directly to the unit controller zone sensor input.

Main Features of Non-Communicating Zone Sensors

- 12 in. probe with mounting plate.
- Stainless steel construction.

SPECIFICATIONS - RETURN AIR DUCT MOUNT ZONE SENSOR (NON-COMMUNICATING)

Unit Controller Compatibility	Prodigy® Unit Controller, Network Thermostat Controller
Temperature Range	40°F to 95°F
Accuracy	+/-0.36°F
Stability	+/-0.23°F
Interchangeability	+/-0.36°F
Sensor Type	NTC thermistor , 11K @76°F
Mounting	Mounting plate for 2 screws
Dimensions	Length: 12 in. Diameter: 1/4 in.
Weight	0.0625 lbs.
Cable Type	Sensor - Lennox yellow COMM cable: COMISC00AE1- (27M19) (500 ft. box), COMISC04AE1- (94L63) (1000 ft. box), COMISC01AE1- (68M25) (2500 ft. roll)

SYSTEM COMPONENTS - SENSORS

AVERAGING ZONE SENSOR KIT - WALL-MOUNT (NON-COMMUNICATING)

C0SNZN71AE1- (23M20)



Two small wall-mounted non-communicating zone sensors that are used for averaging zone temperatures in two locations. These sensors **MUST** be used together.

Main Features of Averaging Zone Sensor Kit

- Kit includes two wall-mounted sensors.
- Terminal block for wiring connections.
- Wired in parallel for simple installation.
- Off-white plastic enclosure.

SPECIFICATIONS - AVERAGING ZONE SENSOR KIT (NON-COMMUNICATING)

Unit Controller Compatibility	Prodigy® Unit Controller, Network Thermostat Controller
Temperature Range	40°F to 95°F
Accuracy	+/-0.36°F (+/-0.2C)
Stability	+/-0.23°F (+/-0.13C)
Interchangeability	+/-0.36°F (+/-0.2C)
Sensor Type	NTC thermistor , 22K @76°F (Each Sensor) Must be connected in parallel
Enclosure	High impact ABS off-white plastic case.
Dimensions (Each Sensor)	Height: 1-1/2 in. Width: 2 in. Depth: 1 in.
Weight	0.12 lbs.
Cable Type	Sensor - Lennox yellow COMM cable: COMISC00AE1- (27M19) (500 ft. box), COMISC04AE1- (94L63) (1000 ft. box), COMISC01AE1- (68M25) (2500 ft. roll)

SYSTEM COMPONENTS - SENSORS

ZONE SENSOR - FLUSH WALL-MOUNT (NON-COMMUNICATING)

C0SNZN04AE1- (76M32)



Non-communicating flush wall-mount zone sensor. Sensor fits a single gang electrical handy box. For applications that require flush mounted wall sensors.

Main Features of Flush Zone Sensor

- Single gang electrical handy box size.
- Stainless steel wall mounting plate.
- Simple two-wire sensor connection.

SPECIFICATIONS - ZONE SENSOR - FLUSH WALL-MOUNT (NON-COMMUNICATING)

Unit Controller Compatibility	Prodigy® Unit Controller, Network Thermostat Controller
Temperature Range	40°F to 95°F
Accuracy	+/-0.36°F
Stability	+/-0.23°F
Interchangeability	+/-0.36°F
Sensor Type	NTC thermistor , 11K @76°F
Cover Material	Stainless steel
Dimensions (Each Sensor)	Height: 4-1/2 in. Width: 2-3/4 in. Depth: 1/8 in.
Weight	0.4 lbs.
Cable Type	Sensor - Lennox yellow COMM cable: C0MISC00AE1- (27M19) (500 ft. box), C0MISC04AE1- (94L63) (1000 ft. box), C0MISC01AE1- (68M25) (2500 ft. roll)

SYSTEM COMPONENTS - SENSORS

CO₂ SENSOR - WALL-MOUNT (NON-COMMUNICATING)

C0SNSR52AE1L (87N53), C0SNSR50AE1L (77N39), C0SNSR53AE1L (87N54), C0SNSR51AE1L (87N52)



Wall mounted non-communicating CO₂ sensors.
Sensors may be used for demand control ventilation.

Main Features of CO₂ Sensors

- C0SNSR52AE1L - Off-white plastic cover, no display.
- C0SNSR50AE1L - Off-white plastic cover with LCD display.
- C0SNSR53AE1L - Black plastic case, no display, UL94-5V rated, may be used in return air duct.
- C0SNSR51AE1L - Black plastic case, LCD display, UL94-5V rated, may be used in return air duct.

All Models

- Plug and play compatible with the Prodigy® Unit Controller on Lennox' premium units.
- Patented absorption infrared gas sensing engine.
- Self-calibration system eliminates the need for manual calibration in most applications.
- Gas permeable, water resistant CO₂ diffusion filter prevents particulate and water contamination of the sensor
- Screw type terminal blocks.
- +/- 40 ppm + 3% of reading up to 1000 ppm
+/- 40 ppm + 5% of reading up to 1000-1200 ppm
+/- 40 ppm + 7% of reading up to 1200-2000 ppm
- Dual outputs (0-10VDC and 4-20mA).

SPECIFICATIONS - CO₂ SENSORS - WALL-MOUNT (NON-COMMUNICATING)

Controller Compatibility	Prodigy® Unit Controller, Building Controller, Network Thermostat Controller
Power Requirements	24VAC (+/-25%), 50/60Hz, 2VA maximum
Operating Conditions	32-122°F 0-95% RH, non-condensing
Measurement Range	400-2000 ppm (0 ppm=0 V, 4mA)
Output Range (Dual)	0-10VDC and 4-20mA
Accuracy	+/- 40 ppm + 3% of reading up to 1000 ppm +/- 40 ppm + 5% of reading up to 1000-1200 ppm +/- 40 ppm + 7% of reading up to 1200-2000 ppm ABC (Automatic Background Calibration) Logic self-calibration system.
Measuring Method	Non-dispersive infrared (NDIR) absorption
Temperature Sensor Type	NTC 10 KΩ thermistor, with 1 KΩ offset in series
Thermistor Accuracy	±1.8° (59 to 95°F)
Display	C0SNSR52AE1L, C0SNSR53AE1L - none C0SNSR50AE1L, C0SNSR51AE1L - LCD type display w/cover
Enclosure	C0SNSR50AE1L, C0SNSR52AE1L - High impact ABS off-white plastic case. C0SNSR51AE1L, C0SNSR53AE1L - High impact ABS black plastic case. UL94-5V rated. (May be used in return duct)
Dimensions	Height: 4-1/2 in. Width: 3-3/16 in. Depth: 1-1/16 in.
Weight	0.5 lbs.

INPUTS / OUTPUTS

Analog Outputs	1- 0-10VDC (100 Ω output impedance) 1- 4-20mA (RL maximum 500 Ω) (Output not used for Lennox controllers)
Temperature Sensor Cable Type	Two-wire (not polarity sensitive)

Wire runs under 50 ft.

2 twisted pair shielded cable (2 Lennox yellow COMM cables):
 C0MISC00AE1- (**27M19**) (500 ft. box),
 C0MISC04AE1- (**94L63**) (1000 ft. box),
 C0MISC01AE1- (**68M25**) (2500 ft. roll)

Wire runs over 50 ft. but under 150 ft.

2 twisted pair shielded cable (18 AWG)

Wire runs over 150 ft.

Requires local isolated power transformer:

C0MISC30AE1- (**18M13**), 24VAC, 20VA maximum
 1 twisted pair shielded cable (1 Lennox yellow COMM cable):
 C0MISC00AE1- (**27M19**) (500 ft. box),
 C0MISC04AE1- (**94L63**) (1000 ft. box),
 C0MISC01AE1- (**68M25**) (2500 ft. roll)

ACCESSORY

Downflow Duct Mounting Kit	C0MISC19AE1- (85L43) - Allows installation of CO ₂ sensor in return air opening of packaged rooftop units in downflow applications
----------------------------	--

CO₂ SENSOR - FIELD WIRING

AC Power 3-Wire System

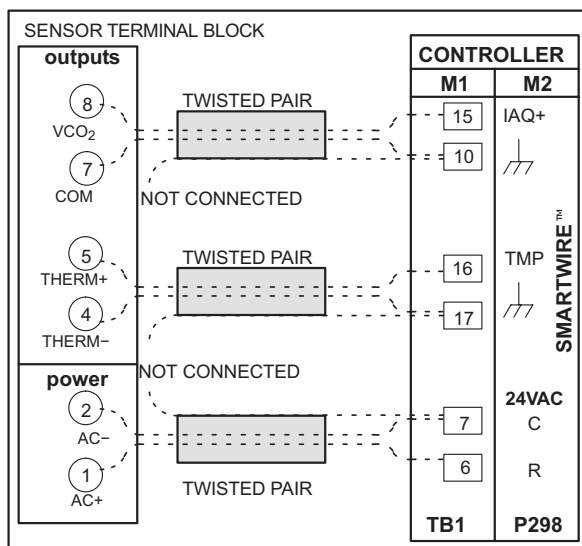

Isolated AC Power 4-Wire System

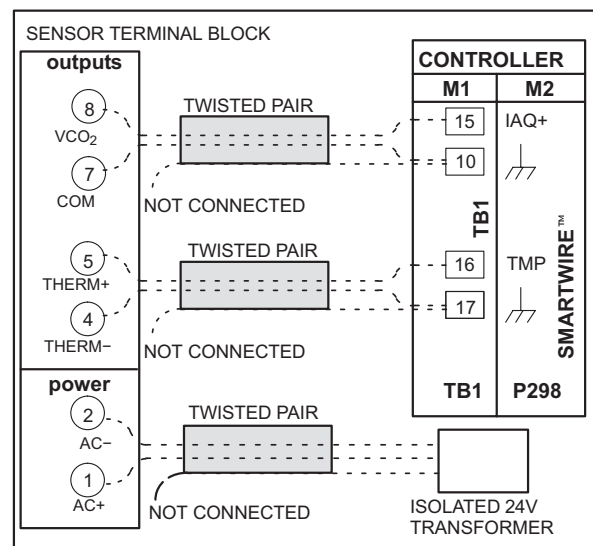

SYSTEM COMPONENTS - CO₂ SENSOR ACCESSORIES

CO₂ SENSOR DUCT MOUNT ASPIRATION BOX

COMISC16AE1- (90N43)



Converts standard wall mount CO₂ sensors to duct mount applications. The custom internal mounting bracket secures the base of the sensor inside the aspiration box. Power is applied by running conduit through a knockout and wiring to the terminal blocks located on the sensor mounting bracket. The enclosure is lightweight, durable, and can be installed in minutes.

Main Features of CO₂ Sensor Duct Mount Aspiration Box

- See-through cover.
- Custom mounting bracket.
- Duct sample tube.
- Choice of knockouts.

SPECIFICATIONS - CO₂ SENSOR DUCT MOUNT ASPIRATION BOX

Sensor Compatibility	Wall mount models - C0SNSR52AE1L (87N53), C0SNSR50AE1L (77N39)
Electrical Knockouts	7/8 in., 1-1/8 in. and 1-1/16 in.
Enclosure Material	ABS plastic
Minimum Air Flow	400 fpm
Dimensions	Height: 7 in. Width: 4-1/4 in. Depth: 3-1/2 in.
Sample Probe Size	Length: 7.00 in. Diameter: 1.125 in.
Weight	2 lbs.

SYSTEM COMPONENTS - SENSORS

REMOTE RELATIVE HUMIDITY SENSOR - WALL-MOUNT (NON-COMMUNICATING)

C0SNSR31AE1- (17M50)



Non-communicating wall mounted RH sensor. Sensor fits a single gang electrical handy box. Sensor may be used for *Humiditrol*® units or units that use the Supermarket reheat feature.

Main Features of Remote Relative Humidity Sensor

- Terminal blocks for wiring connections.
- Relative humidity range: 0 -100%.
- +/- 3% Accuracy.
- Off-white plastic enclosure.

SPECIFICATIONS - REMOTE RELATIVE HUMIDITY SENSOR - WALL-MOUNT

Controller Compatibility	Prodigy® Unit Controller, Building Controller, Network Thermostat Controller
Operating Environment	Temperature: -10°F to 160°F Humidity: 0-95% RH, non-condensing
Power Requirements	24VAC, +/- 25%, 50/60Hz, 1.5 VA
RH Range	5-95%
Accuracy	+/-3% RH from 20 to 95% RH @77°F
Enclosure	High impact ABS off-white plastic case
Dimensions	Height: 4-1/2 in. Width: 2-3/4 in. Depth: 1-1/8 in.
Weight	0.3 lbs.
INPUTS / OUTPUTS	
Analog Output	0-10VDC, 0-5VDC or 4-20mA (0-10VDC is used for Prodigy® Unit Controller, Building Controller and Network Thermostat Controller)
Cable Type	<p>Wire runs under 50 ft. 2 twisted pair shielded cable (2 Lennox yellow COMM cables): C0MISC00AE1- (27M19) (500 ft. box), C0MISC04AE1- (94L63) (1000 ft. box), C0MISC01AE1- (68M25) (2500 ft. roll)</p> <p>Wire runs over 50 ft. but under 150 ft. 2 twisted pair shielded cable (18 AWG)</p> <p>Wire runs over 150 ft. Requires local isolated power transformer: C0MISC30AE1- (18M13), 24VAC, 20VA maximum 1 twisted pair shielded cable (1 Lennox yellow COMM cable): C0MISC00AE1- (27M19) (500 ft. box), C0MISC04AE1- (94L63) (1000 ft. box), C0MISC01AE1- (68M25) (2500 ft. roll)</p>

SYSTEM COMPONENTS - SENSORS

RETURN AIR DUCT RELATIVE HUMIDITY SENSOR (NON-COMMUNICATING)

C0SNSR30AE1- (76M31)

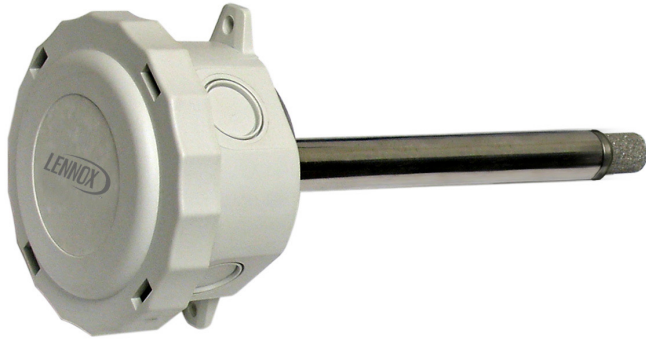

Non-communicating return air duct mounted RH sensor designed for applications that require mounting the sensor in the return air duct. Sensor may be used for *Humiditrol*® units or units that use the Supermarket reheat feature.

Main Features of Return Air Duct Relative Humidity Sensor

- Terminal blocks for wiring connections.
- Relative humidity range: 0 -100%.

SPECIFICATIONS - RETURN AIR DUCT RELATIVE HUMIDITY SENSOR

Controller Compatibility	Prodigy® Unit Controller, Building Controller, Network Thermostat Controller
Operating Environment	Temperature: -10°F to 160°F Humidity: 0-95% RH, non-condensing
Power Requirements	24VAC (+/-25%), 50/60Hz, 1.5 VA
RH Range	5-95%
Accuracy	+/-3% RH from 20 to 95% RH @77°F
Enclosure	High impact ABS off-white plastic case
Dimensions:	Electronics Enclosure: 4 in. dia x 2-1/4 in. Duct Probe: 7-7/8 in. x 3/4 in. diameter
Weight	1 lbs.
INPUTS / OUTPUTS	
Analog Output	0-10VDC, 0-5VDC or 4-20mA (0-10VDC is used for Prodigy® Unit Controller, Building Controller and Network Thermostat Controller)
Cable Type	Wire runs under 50 ft. 2 twisted pair shielded cable (2 Lennox yellow COMM cables): C0MISC00AE1- (27M19) (500 ft. box), C0MISC04AE1- (94L63) (1000 ft. box), C0MISC01AE1- (68M25) (2500 ft. roll) Wire runs over 50 ft. but under 150 ft. 2 twisted pair shielded cable (18 AWG) Wire runs over 150 ft. Requires local isolated power transformer: C0MISC30AE1- (18M13), 24VAC, 20VA maximum 1 twisted pair shielded cable (1 Lennox yellow COMM cable): C0MISC00AE1- (27M19) (500 ft. box), C0MISC04AE1- (94L63) (1000 ft. box), C0MISC01AE1- (68M25) (2500 ft. roll)

SYSTEM COMPONENTS - SENSORS

REMOTE DISCHARGE TEMPERATURE SENSOR KIT

C1SNSR75AD1 (58W63)

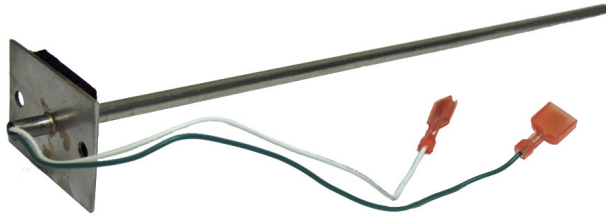

The Remote Discharge Temperature Sensor Kit is for applications that use the Discharge Air Control or Fresh Air Tempering feature available in all Lennox' premium rooftop units. This kit replaces the discharge air temperature sensor that is standard in these units. The kit includes a Duct Temperature Sensor C0SNDC04AE1- (99K64) and 22 ft. of cable.

SPECIFICATIONS - REMOTE DISCHARGE TEMPERATURE SENSOR KIT

Controller Compatibility	Prodigy® Unit Controller, Network Thermostat Controller
Accuracy	+/-0.36°F
Stability	+/-0.23°F
Interchangeability	+/-0.36°F
Sensor Type	NTC thermistor , 10K @76°F
Mounting	Mounting plate for 2 screws (Duct Mount)
Dimensions	Length: 12 in. Diameter: 1/4 in.
Weight	0.0625 lbs.
Cable Included	2 - 18AWG 105C wire (22 ft.)

SYSTEM COMPONENTS - SENSORS

OUTDOOR AIR CONTROL SENSOR KIT

C0SNSR23DE1- (98M61)

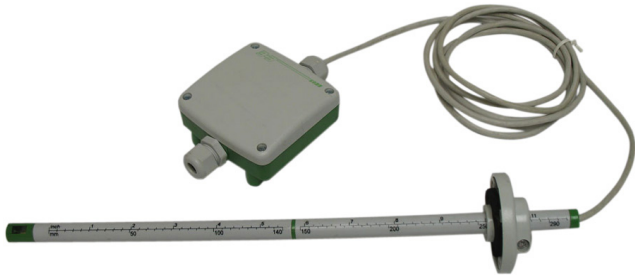

The Outdoor Air Control Sensor Kit is an air velocity sensor that can be used on Lennox' premium rooftop units. The kit also includes a wiring harness, mounting bracket and includes an I/O Module Kit C0CTRL01AE1L (86M39).

Main Features of Outdoor Air Control Sensor Kit

- Three field selectable air velocity ranges.
- Includes I/O Module Kit C0CTRL01AE1L (86M39).
- Innovative hot film anemometer principle.

The sensor is used for modulating the economizer (outdoor air damper) to hold the outside air flow rate constant. The sensor may also be used with the Building Controller for monitoring air flow and setting alarms or controlling digital outputs.

SPECIFICATIONS - OUTDOOR AIR CONTROL SENSOR KIT

Controller Compatibility	Prodigy® Unit Controller - All versions Building Controller
Operating Environment	Temperature: 14°F to 122°F
Power Requirements	24VAC (+/-25%), 50/60Hz, 3.6VA maximum
Air Flow Ranges	0 to 984 ft./min. (Adjustable by jumpers) 0 to 1480 ft./min. (Adjustable by jumpers) 0 to 1970 ft./min. (Adjustable by jumpers)
Accuracy	+/- 0.5 ft./sec +3% (for 0 to 984 ft./min. range) +/- 1 ft./sec +3% (for 0 to 1480 ft./min. range) +/- 1 ft./sec +4% (for 0 to 1970 ft./min. range)
Response Time	4 sec. or 0.2 sec. (Adjustable by jumpers)
Electrical Connections	Screw terminal block
Output	0-10VDC, 4-20mA (Adjustable by jumpers)
Dimensions (electronics)	Height: 3-1/8 in. Width: 3-1/8 in. Depth: 1-1/2 in.
Dimensions (probe)	8 length x 1/2 in. diameter
Enclosure	Polycarbonate NEMA 4
Weight	0.5 lbs.
Cable Type	2 - Lennox yellow COMM cables: COMISC00AE1- (27M19) (500 ft. box), COMISC04AE1- (94L63) (1000 ft. box), COMISC01AE1- (68M25) (2500 ft. roll)

NOTE - See the I/O Module Kit on page 21 for specifications.

OUTDOOR AIR CONTROL SENSOR KIT - FIELD WIRING

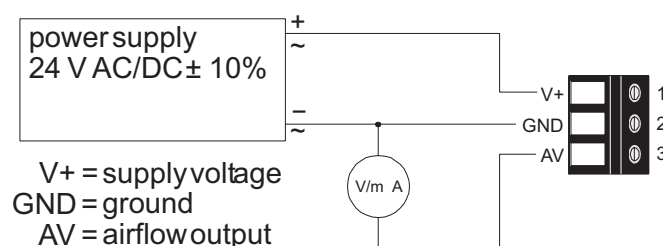

SYSTEM COMPONENTS - SENSORS

OUTDOOR TEMPERATURE SENSOR

C0SNSR02AE1- (59M05)



Outdoor temperature sensor used primarily with the Building Controller and Network Thermostat Controller. It has a water-proof plastic wiring enclosure. The temperature sensor is surrounded by a vented aluminum enclosure to reduce the effect of wind and sunlight on the temperature measurement.

Main Features of Outdoor Temperature Sensor

- Water-proof wiring junction box with conduit knockouts.
- Vented aluminum cover around sensor.
- Compatible with the Building Controller and the Network Thermostat Controller.

SPECIFICATIONS - OUTDOOR TEMPERATURE SENSOR

Controller Compatibility	Building Controller, Network Thermostat Controller
Accuracy	+/-0.36°F
Stability	+/-0.23°F
Interchangeability	+/-0.36°F
Sensor Type	NTC thermistor , 10K @76°F
Dimensions	Width: 4 in. Height: 6-3/4 in. Depth: 2-1/4 in.
Enclosure	Water-proof plastic junction box (White)
Weight	0.4 lbs.
Cable Type	Sensor - Lennox yellow COMM cable: COMISC00AE1- (27M19) (500 ft. box), COMISC04AE1- (94L63) (1000 ft. box), COMISC01AE1- (68M25) (2500 ft. roll)

SYSTEM COMPONENTS - SENSORS

DUCT TEMPERATURE SENSOR

C0SND04AE1- (99K64)

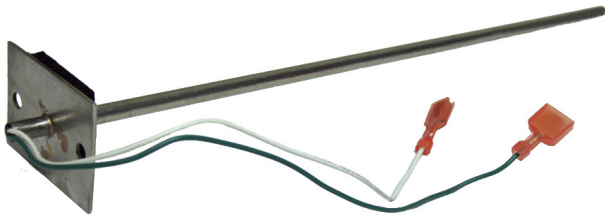

When used with Network Thermostat Controller applications, the Duct Temperature Sensor displays the return air temperature on the Network Control Panel and software program display screens. This sensor will act as a backup in case the zone sensor has a wiring problem or malfunctions. It will also allow the use of the return air limit option.

Building Controller Applications

When used with Building Controller applications, the sensor can be used to display the temperature at the Network Control Panel and software program display screens. It can also be used to override an output.

SPECIFICATIONS - DUCT TEMPERATURE SENSOR

Controller Compatibility	Prodigy® Unit Controller, Building Controller, Network Thermostat Controller
Accuracy	+/-0.36°F
Stability	+/-0.23°F
Interchangeability	+/-0.36°F
Sensor Type	NTC thermistor , 10K @76°F
Mounting	Mounting plate for 2 screws
Dimensions	Length: 12 in. Diameter: 1/4 in.
Weight	0.0625 lbs.
Cable Type	Sensor - Lennox yellow COMM cable: C0MISC00AE1- (27M19) (500 ft. box), C0MISC04AE1- (94L63) (1000 ft. box), C0MISC01AE1- (68M25) (2500 ft. roll)

SYSTEM COMPONENTS - SENSORS

TEMPERATURE SENSOR PROBE

C0SNSR05AE1- (14K92)

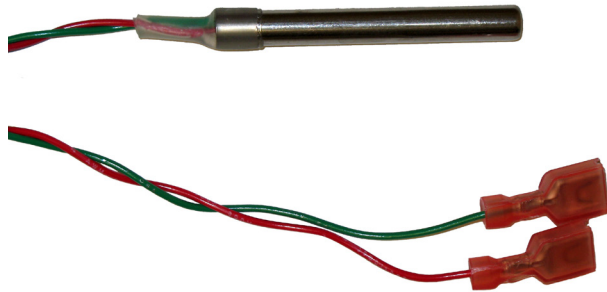

When used with Network Thermostat Controller applications, the Temperature Sensor Probe displays the return air temperature on the Network Control Panel and software program display screens. It can also be used as a general purpose sensor to monitor refrigerated coolers, ice makers, etc. The sensor also allows the low ambient compressor control option and allows use of the heat pump supplemental heat lockout option that keeps the supplemental heat off if outside air temperature is above the selected set-point.

Building Controller Applications

When used with Building Controller applications, the sensor can be used to display the temperature at the Network Control Panel and software program display screens

SPECIFICATIONS - TEMPERATURE SENSOR PROBE

Controller Compatibility	Prodigy® Unit Controller, Building Controller, Network Thermostat Controller
Accuracy	+/-0.36°F
Stability	+/-0.23°F
Interchangeability	+/-0.36°F
Sensor Type	NTC thermistor , 10K @76°F
Mounting	Mounting plate for 2 screws
Dimensions	Length: 3 in. Diameter: 1/4 in.
Weight	0.06 lbs.
Cable Type	Sensor - Lennox yellow COMM cable: C0MISC00AE1- (27M19) (500 ft. box), C0MISC04AE1- (94L63) (1000 ft. box), C0MISC01AE1- (68M25) (2500 ft. roll)

SYSTEM COMPONENTS - SENSORS

SUPPLY STATIC DIFFERENTIAL PRESSURE SENSOR

COSNSR20AE1 (78M19)

The Supply Static Differential Pressure Sensor has three operating ranges and three output options.



Main Features of Supply Static Pressure Sensor

- Pre-set to 0 - 5.0 in. w.c. range and 0-10VDC output.
- Additional ranges and outputs are available by hanging mini-jumpers.
- NIST traceable calibration.
- Compatible with Prodigy® Unit Controller and Network Thermostat Controller Bypass Controller.

SPECIFICATIONS - SUPPLY STATIC DIFFERENTIAL PRESSURE SENSOR

Controller Compatibility	Prodigy® Unit Controller - All versions Building Controller Network Thermostat Controller Bypass Controller
Operating Environment	0 to 175°F 10 to 90% RH
Compensated Temperature Range	25 to 150°F
Power Requirements	24VAC (+/-25%), 50/60Hz, 0.5VA maximum
Operating pressure range	0 - 5 in. w.c., 0 - 2.5 in. w.c., 0 -1.25 in. w.c. (adjustable) Factory Setting: 0 - 5 in. w.c.
Accuracy	+/- 1% F.S.
Overpressure	10 PSID
Output	0-10VDC, 0-5VDC, 4-20mA Factory setting - 0-10VDC
Media Compatibility	Clean dry air or any inert gas
Termination	Un-pluggable screw terminal block
Enclosure	Steel NEMA 4, aluminum probe
Dimensions	Height: 6 in. Width: 4 in. (with mounting tabs) Depth: -2-1/4 in. Probe length: 8 in.
Weight	1 lbs.
Cable Type	Wire runs under 50 ft. 2 twisted pair shielded cable (2 Lennox yellow COMM cables): COMISC00AE1- (27M19) (500 ft. box), COMISC04AE1- (94L63) (1000 ft. box), COMISC01AE1- (68M25) (2500 ft. roll) Wire runs over 50 ft. but under 150 ft. 2 twisted pair shielded cable (18 AWG) Wire runs over 150 ft. Requires local isolated power transformer: COMISC30AE1- (18M13), 24VAC, 20VA maximum 1 twisted pair shielded cable (1 Lennox yellow COMM cable): COMISC00AE1- (27M19) (500 ft. box), COMISC04AE1- (94L63) (1000 ft. box), COMISC01AE1- (68M25) (2500 ft. roll)

SUPPLY STATIC DIFFERENTIAL PRESSURE SENSOR - FIELD WIRING

Legend
S = Span Adjust
Z = Zero Adjust
+ = Supply Voltage
- = Common
(Neutral)
0 = Output

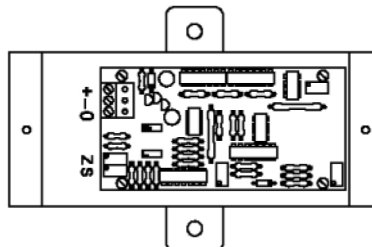

SYSTEM COMPONENTS - SENSORS

RETURN (BUILDING) STATIC DIFFERENTIAL PRESSURE SENSOR

C0SNSR21AE1- (78M20)

The Return (Building) Static Differential Pressure Sensor has three operating ranges and three output options. It is used with optional power exhaust fans to control building static pressure on Lennox' premium rooftop units.



Main Features of Building Static Pressure Sensor

- Pre-set to -0.5 to 0.5 in. w.c. range and 0 to 10VDC output for Prodigy® Unit Controller.
- Additional ranges and outputs are available by changing mini-jumpers.
- Compatible with Prodigy® Unit Controller.
- C0SNSR22AE1- (79M21) Outdoor Air Weather Head required for reducing outdoor static pressure fluctuations.

SPECIFICATIONS - BUILDING (RETURN) STATIC DIFFERENTIAL PRESSURE SENSOR

Controller Compatibility	Prodigy® Unit Controller - All versions Building Controller
Operating Temperature	0 to 175°F 10 to 90% RH
Compensated Temperature Range	25 to 150°F
Power Requirements	24VAC (+/-25%), 50/60Hz, 0.5VA maximum
Operating Range	0 - 1.0 in. w.c., 0 - 0.5 in. w.c., 0 - 0.25 in. w.c., -0.5 - 0.5 in. w.c., -0.25 - 0.25 in. w.c., -0.125 - 0.125 in. w.c. Factory Setting is -0.5+0.5 in. w.c.
Accuracy	+/- 1% F.S.
Overpressure	10 PSID
Output	0-10VDC, 0-5VDC, 4-20mA Factory Settings is 0-10VDC
Enclosure	Steel NEMA 4, aluminum probe
Media Compatibility	Clean dry air or any inert gas
Termination	Un-pluggable screw terminal block
Dimensions	Height: 6 in. Width: 4 in. (with mounting tabs) Depth: 2-1/4 in.
Weight	1 lbs.
Cable Type	Wire runs under 50 ft. 2 twisted pair shielded cable (2 Lennox yellow COMM cables): C0MISC00AE1- (27M19) (500 ft. box), C0MISC04AE1- (94L63) (1000 ft. box), C0MISC01AE1- (68M25) (2500 ft. roll) Wire runs over 50 ft. but under 150 ft. 2 twisted pair shielded cable (18 AWG) Wire runs over 150 ft. Requires local isolated power transformer: C0MISC30AE1- (18M13), 24VAC, 20VA maximum 1 twisted pair shielded cable (1 Lennox yellow COMM cable): C0MISC00AE1- (27M19) (500 ft. box), C0MISC04AE1- (94L63) (1000 ft. box), C0MISC01AE1- (68M25) (2500 ft. roll)

SUPPLY STATIC DIFFERENTIAL PRESSURE SENSOR - FIELD WIRING

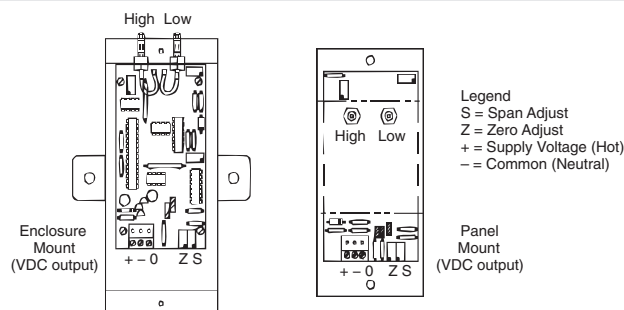

SYSTEM COMPONENTS - SENSORS

AMBIENT LIGHT SENSOR

COSNSR60AE1- (34M67)



Outdoor ambient light sensor for use with the Building Controller and Network Control Panel for automatic lighting control.

Main Features of Ambient Light Sensor

- Monitors wide range of light.
- Linear output voltage.
- Electronics encased in a clear epoxy and sealed with an electronic grade non-corrosive urethane resin.

SPECIFICATIONS - AMBIENT LIGHT SENSOR

Controller Compatibility	Building Controller
Operating Power	12VDC (provided by Building Controller)
Output Voltage	0-10VDC
Light Sensor Range	0 - 15 FC
Dimensions (diameter x length)	1-1/4 x 2-9/16 in.
Enclosure	White PVC plastic case. Electronics encased in a clear epoxy and sealed with an electronic grade, non-corrosive urethane resin.
Mounting	Mounts to a standard threaded 1/2 in. conduit or 1/2 in. knockout.
Weight	1 lbs.
Cable Type	3-conductor thermostat cable , 18 AWG min.

SYSTEM COMPONENTS - SENSORS

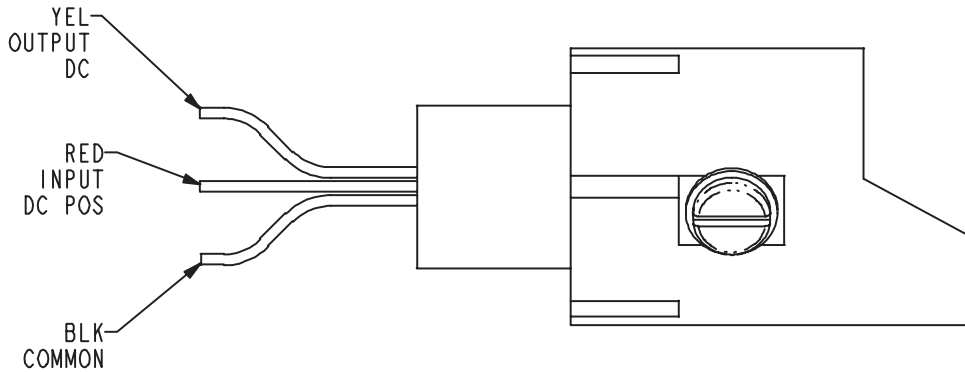

SYSTEM COMPONENTS - NETWORK

NETWORK REPEATER

C0CTRL51AE1L (11W30)



The Network Repeater connects two-wire EIA-485 devices and networks together without danger of ground loops and damaging surges. It also doubles permitted cable length. Data signals have 2.5kV optical isolation. Isolated DC supplies provide full three-port galvanic

isolation. The signal (reference) ground for both EIA-485 ports float with respect to power supply ground. Jumpers enable 120 ohm internal terminating and bias resistors. 500 watt voltage transient suppressor diodes protect the Network Repeater from normal mode surges, while the full galvanic isolation protects it from common mode surges.

Main Features of the Network Repeater

- 2.5kV optical isolation.
- Doubles the permitted network cable length.
- Operates up to 115k baud.
- DIN rail mounting.

SPECIFICATIONS - NETWORK REPEATER

Operating Environment	Temperature: -40°F to 149°F Humidity: 10% - 95% RH, Non- Condensing
Power Requirements	5V DC +/- 5% 9V to 36V DC 120VAC power supply included
Isolation (ISO/IEC 9549)	EIA-485 to EIA-485 - 2500 V (optical, 5kV test) Supply to field - 2500 V (galvanic, 3kV test) Supply to local - 2-port = none ; 3-port = 2500V
Communications	Max Speed - At least 115 Kbps over 500m Character Setting - transparent, no configuration required User Indications - Each receive signal has LED (yellow) Standard Distance - 4000 ft.
Case Material	Nylon polyimide, fungus and termite resistant, self-extinguishing, epoxy potting
Mounting Rail	DIN EN 50022 or 50035
Dimensions	Height: 3 in. Width: 3 in. Depth: 1 in.
Weight	0.2 lbs .
INPUTS / OUTPUTS	
EIA-485 Ports	Signal Type : EIA-485A Voltage Level : -7 to +12 VDC Permitted Surge : +/- 25 VDC
Approvals	UL - 873 Plenum rated Canadian UL - cUL C22.2 No. 24-93 CE - 89/336/ECC, 73/23/ECC C-Tick - N314
Cable Type	SysBus - Lennox yellow COMM cable: COMISC00AE1- (27M19) (500 ft. box), COMISC04AE1- (94L63) (1000 ft. box), COMISC01AE1- (68M25) (2500 ft. roll) OR ZoneBus - Lennox purple COMM cable: COMISC05AE1- (23W99) (500 ft. box) COMISC06AE1- (24W00) (1000 ft. box) COMISC07AE1- (24W01) (2500 ft. roll) Power - Cable provided with kit

NETWORK REPEATER - FIELD WIRING

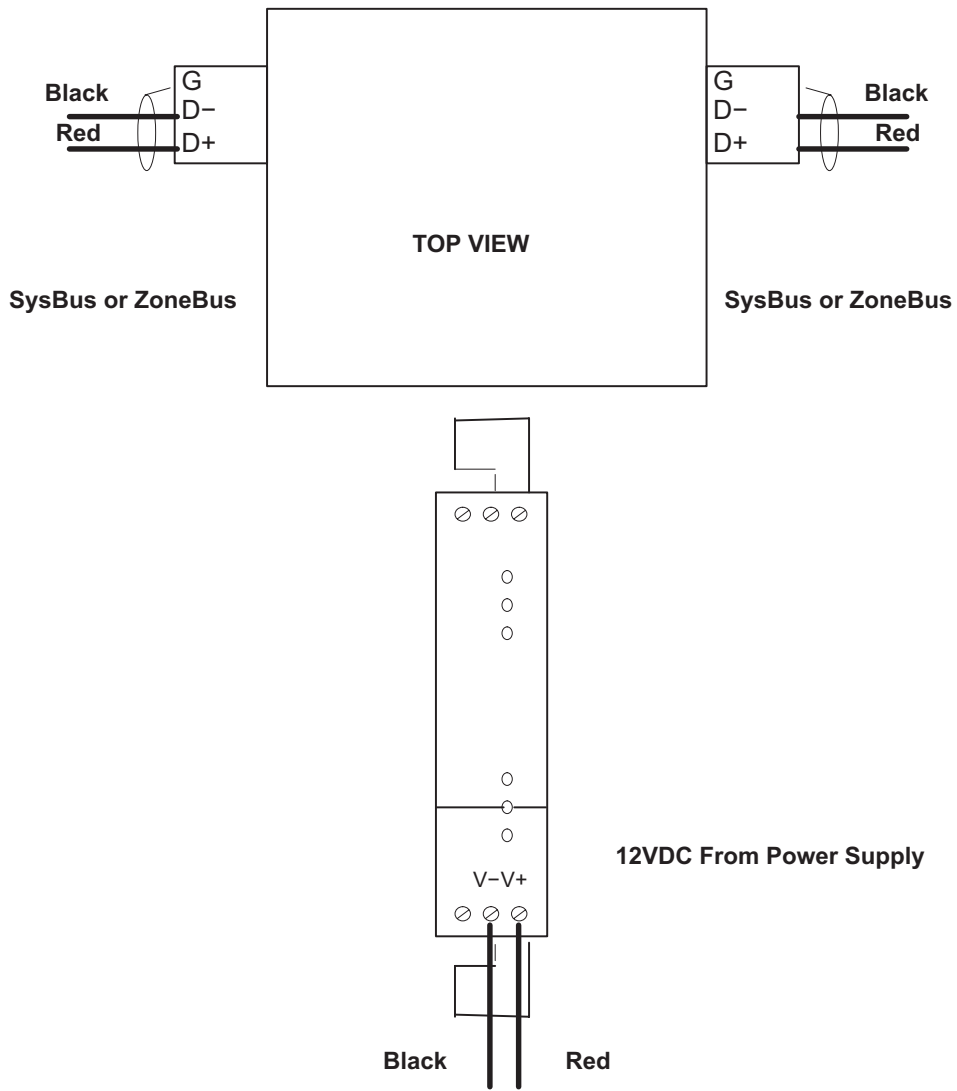

SYSTEM COMPONENTS - NETWORK

SURGE PROTECTOR

COMISC92AE1- (23W22)



Protects two-wire EIA-485 circuits such as the Lennox SysBus or ZoneBus. Built-in self-resetting current limiters both eliminate the need for external fuses and protects from common continuous over-voltage faults.

Main Features of the Surge Protector

- Up to 20kA impulse discharge (8/20 μ s wave).
- Self-resetting current limited to 250mA.
- Simplifies ground wire installation.

SPECIFICATIONS - SURGE PROTECTOR

Operating Environment	Temperature: -40°F to 149°F Humidity: 10% - 95% RH, Non- Condensing
Nominal Operating Voltage	+/-15V DC
Nominal Operating Current	Less than 250mA
Series Resistance	6.5 ohms @25C
Impulse Discharge Current	20kA (wave form 8/20 μ s)
Current Limit	PTC device
Course Protection	Ceramic Gas Discharge Tube
Fine Protection	High Speed Transient Suppressor Diode
Communication Speed Range	300 to 115 Kbps
Case Material	Nylon polymide, fungus and termite resistant, self-extinguishing, epoxy potting
Mounting Rail	DIN EN 50022 or 50035
Dimensions	Height: 3 in. Width: 3 in. Depth: 1 in.
Weight	0.2 lbs.
INPUTS / OUTPUTS	Field Network - (D0+/Tx, Earth, DO-/Rx) Equipment Network - (D1+/Tx, SGnd, D1-/Rx)
Cable Type	SysBus - Lennox yellow COMM cable: COMISC00AE1- (27M19) (500 ft. box), COMISC04AE1- (94L63) (1000 ft. box), COMISC01AE1- (68M25) (2500 ft. roll) OR ZoneBus - Lennox purple COMM cable: COMISC05AE1- (23W99) (500 ft. box) COMISC06AE1- (24W00) (1000 ft. box) COMISC07AE1- (24W01) (2500 ft. roll) Earth Ground - 18AWG minimum

SYSTEM COMPONENTS - NETWORK

NETWORK BUS TO PC CONVERTER KIT

COMISC47AE1- (96L78)



The Network to PC converter is an EIA-232 to Lennox SysBus and ZoneBus data converter. The converter is powered from the PC serial port. It has a 9-pin connector for the PC serial connection. It has two Lennox network connectors, a phone jack and a two-position screw terminal block.

Main Features of the Network to PC Converter

- Required for direct (local) connection between the L Connection (SysBus and ZoneBus) Network and a PC running L Connection Network PC software.
- Plugs directly into PC serial connector (9-pin).
- Has phone jack and terminal block connector for L Connection Network (SysBus and ZoneBus).
- Data transmit and data receive LEDs.
- No transformer required.
- Self-powered through the PC.
- Phone cord (15 ft.) for direct connection to any L Connection Network device included.

SPECIFICATIONS - NETWORK BUS TO PC CONVERTER

Operating Power	Self-powered through PC serial port
Operating Temperature	0°F to 120°F
PC Connector (Serial Port)	9-pin, D-type
Network Bus Connectors	2 screw type terminal blocks RJ9 type phone jack (handset type)
Network Bus Indicators	2 red LEDs , data transmit and data receive
Maximum Network Bus Speed	38.4k baud
Dimensions	Height: 1 in. Width: 2-1/4 in. Depth: 2-3/4 in.
Weight	0.5 lbs.
Cable Type	L Connection phone cord (furnished) or Lennox yellow COMM cables: COMISC00AE1- (27M19) (500 ft. box), COMISC04AE1- (94L63) (1000 ft. box), COMISC01AE1- (68M25) (2500 ft. roll)

SYSTEM COMPONENTS - NETWORK

NETWORK MODEM KIT

C0MISC46AE1- (94L62)



The Network Modem Kit for the L Connection Network allows remote access to the network via the L Connection PC software. Kit includes phone modem, network modem converter, wall mount transformer and phone cable.

Main Features of Network Modem Kit

- Connects phone line directly to L Connection Network for remote access.
- Specially programmed for the L Connection Network.
- Network transmit, receive and connect LEDs.

SPECIFICATIONS - NETWORK MODEM KIT

Unit Controller PC Software Compatibility	All versions
Network Control Panel PC software Compatibility	All versions
Operating Power	Wall-plug 120VAC transformer included.
LED Indicators	Phone Modem : AA- Auto Answer Mode, CD- Carrier Detect, RD- Received Data, SD- Send Data, TR- Data Terminal Ready, CS-Clear To Send Network Modem Converter: Data Transmit, Data Receive
Dimensions	Height: 1-1/2 in. Width: 6-5/8 in. Depth: 6-5/8 in. (with network modem converter)
Enclosure	High impact ABS white or black plastic case.
Weight	2 lbs.
INPUTS / OUTPUTS	
Connections	Network: 2-position screw terminal block Phone: Phone Jack RJ11
Cable Type	Network Lennox yellow COMM cable: C0MISC00AE1- (27M19) (500 ft. box), C0MISC04AE1- (94L63) (1000 ft. box), C0MISC01AE1- (68M25) (2500 ft. roll) Phone: Phone cable with plug (furnished)
Agency	FCC approved (Part 15 Class B/Part 68) IC approved (ICES-003/CS-03) UL/ULC listed

SYSTEM COMPONENTS - NETWORK

PHONE LINE AUTO-ROUTER

COMISC41AE1- (34M22)



The Phone Line Auto-Router is a telephone line sharing device that allows the L Connection modem to share a phone line with a phone and or fax machine.

Automatically routes all voice, fax and modem calls to the right equipment - eliminating the need for costly dedicated phone lines.

Programmed security code automatically routes the incoming calls to the modem.

Main Features of Phone Line Auto-Router

- Allows Network Modem to share a phone line with a phone and fax machine.
- Uses security code to automatically route the incoming call to the modem.
- May be used to connect up to three modems on one phone line.
- No professional rewiring is required for use in single-line businesses.
- Complete compatibility with existing equipment and easy to program.
- “Caller ID” compatibility and silent transferring between equipment.
- “Power/Call Status” light, non-volatile memory that saves programming in case of a power outage.
- 120VAC transformer (wall-plug) included.

SPECIFICATIONS - PHONE LINE AUTO-ROUTER

Operating Power	Wall-plug 120VAC transformer included.
Dimensions	Height: 2-1/2 in. Width: 8-1/8 in. Depth: 1-1/2 in.
Enclosure	High impact ABS white plastic case.
Weight	5 lbs.
INPUTS / OUTPUTS	
Cable Type	Phone cable with plug

SYSTEM COMPONENTS - NETWORK

ETHERNET CONVERTER KIT

COMISC43AE1L (76M77)



The Ethernet Converter Kit is required to interface between the L Connection Network and an Ethernet local area network (LAN). It allows the user to monitor and control devices on the L Connection Network from any PC on the LAN that has Network Control Panel PC Software or Unit Controller PC Software installed. If the user has access to the LAN from outside their firewall, they can also monitor and control the L Connection Network remotely via the Internet using the same software installed on their remote PC. LED indicators monitor traffic flow and diagnostics.

Kit includes:

- Ethernet Converter.
- 6 ft. Ethernet patch cable.
- Modem converter.
- Power transformer.

NOTE - Network Control Panel PC Software or Unit Controller PC Software must be ordered separately (version 2.05 or higher is required).

SPECIFICATIONS - ETHERNET CONVERTER KIT

Unit Controller PC Software Compatibility	Version 2.05 or higher
Network Control Panel PC Software Compatibility	Version 2.05 or higher
Operating Power	9 to 30VDC, 1VA maximum 115V transformer (wall-plug type) included
Operating Temperature	41°F to 122°F
Serial Interface	Lennox L Connection Network (EIA-485) Connector: Screw Terminal Block (2)
LAN Interface	Ethernet 10Base-T/100Base-TX Connector: RJ45 Standards: TCP/IP and DHCP
LED Indicators	10 link/activity (green), 100 link/activity (green), collision (red), diagnostics (red), status (green)
Dimensions	Height: 6-1/2 in. Width: 3-9/16 in. Depth: 1 in.
Enclosure	Gray metal and gray plastic
Weight	1 lbs.
Cable Type	Lennox yellow COMM cable for L Connection SysBus: COMISC00AE1- (27M19) (500 ft. box), COMISC04AE1- (94L63) (1000 ft. box), COMISC01AE1- (68M25) (2500 ft. roll) Ethernet patch cable (furnished)

SYSTEM COMPONENTS - NETWORK

SERVICE TUBE KIT

(59W52)

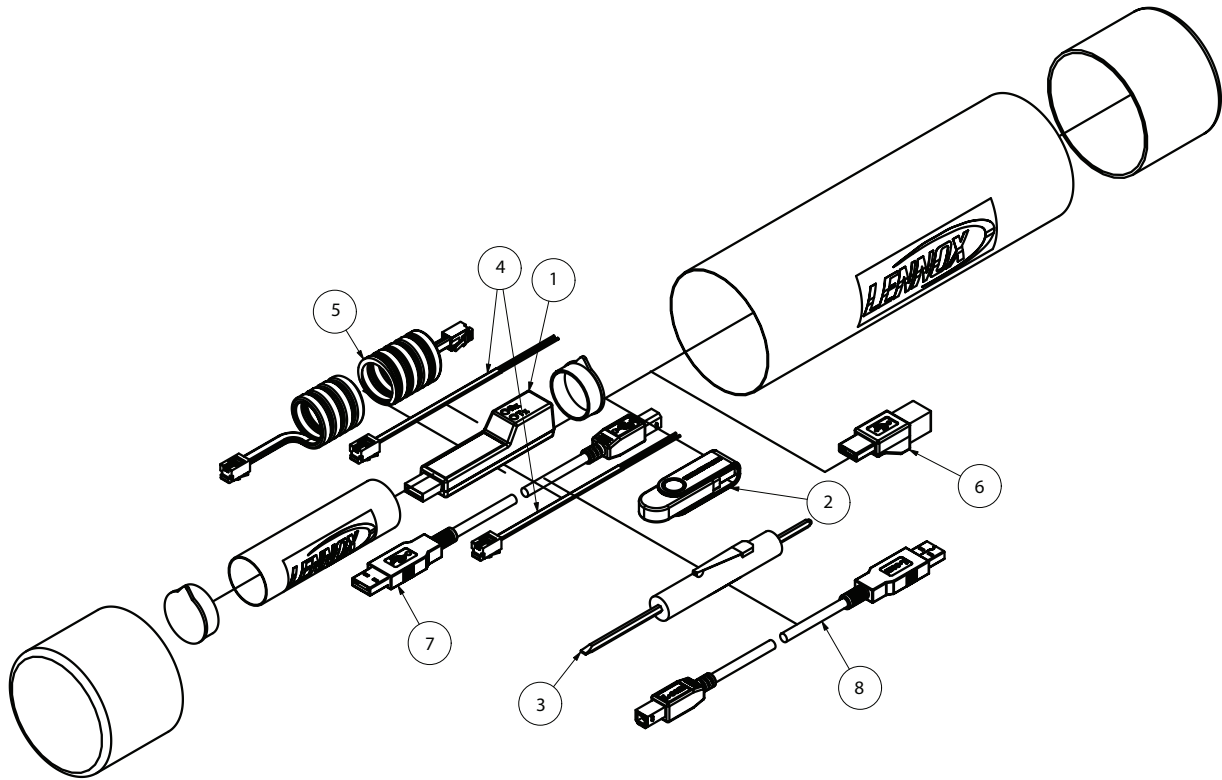

Service Tube Kit contains components to service both legacy L Series® units and Emergence® units via a laptop or PC. Since the connections differ on legacy units and today's models, the Service Tube Kit is a comprehensive collection of all necessary adaptors and cables needed to connect to and service Lennox rooftop units.

Key	Component	Qty.
1	Cobra USB adaptor, USB male to RS485	1
2	Flash Drive, 2GB	1
3	Flathead screwdriver	1
4	Cable with modular plug, 4 connector, 5 in.	2
5	Coiled cable assembly, modular plug at each end, 4 connector, 7 ft.	1
6	USB adaptor, A male A to B female	1
7	USB extension cable, A male to A female, 6 ft.	1
8	USB extension cable, A male to B male B, 6 ft.	1

SYSTEM COMPONENTS - NETWORK

L CONNECTION® SYSBUS NETWORK CABLE

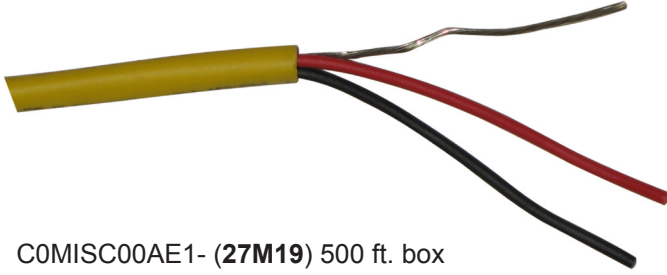

C0MISC00AE1- (27M19) 500 ft. box
 C0MISC04AE1- (94L63) 1000 ft. box
 C0MISC01AE1- (68M25) 2500 ft. roll

SPECIFICATIONS - SYSBUS NETWORK CABLE

Type	Twisted pair 100% shielded communication cable 22 AWG, yellow jacket, rated at 75°C, 300V Plenum rated Insulation - Low smoke PVC NEC, CMP
Color	Outside jacket- Yellow, with order number imprinted Twisted pair - Red and Black
Weight	C0MISC00AE1- 8 lbs. C0MISC04AE1- 14 lbs. C0MISC01AE1- 30 lbs.
Lengths	C0MISC00AE1- (500 ft. box) C0MISC04AE1- (1000 ft. box) C0MISC01AE1- (2500 ft. roll)

L CONNECTION® ZONEBUS NETWORK CABLE

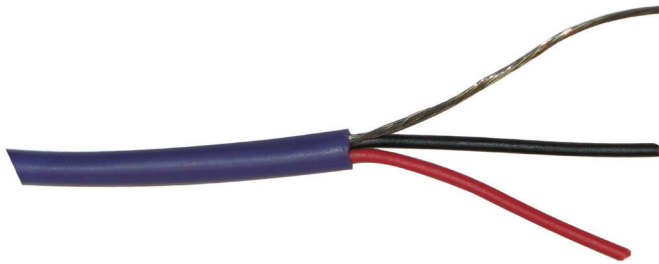

C0MISC06AE1- (24W00) 1000 ft. box
 C0MISC07AE1- (24W01) 2500 ft. roll

SPECIFICATIONS - SYSBUS NETWORK CABLE

Type	Twisted pair 100% shielded communication cable 22 AWG, yellow jacket, rated at 75°C, 300V Plenum rated Insulation - Low smoke PVC NEC, CMP
Color	Outside jacket- Yellow, with order number imprinted Twisted pair - Red and Black
Weight	C0MISC00AE1- 8 lbs. C0MISC04AE1- 14 lbs. C0MISC01AE1- 30 lbs.
Lengths	C0MISC00AE1- (500 ft. box) C0MISC04AE1- (1000 ft. box) C0MISC01AE1- (2500 ft. roll)

SYSTEM COMPONENTS - SOFTWARE

NETWORK CONTROL PANEL PC SOFTWARE

C0SOFT11AE1- (96L82)



The Network Control Panel PC Software is a Microsoft® Windows® based program for interfacing directly with the Network Control Panel through a personal computer.

Features and Benefits:

- Local access through a computer that is tied in directly to an L Connection Network via a serial COM port.
- Remotely access the Network Control Panel through an L Connection Network Modem or Ethernet Converter.
- Set-up the Network Control Panel settings and programs from a PC.
- Can be used to set-up building schedules “off-line”.
- Easily and quickly upload saved schedules at a later date.
- Modify setpoints and monitor the status of each controller connected to the Network Control Panel.
- View controller alarms stored in the Network Control Panel.
- Displays unit operating mode including current zone temperature, heating and cooling setpoints, CO₂ levels (optional CO₂ sensor required), humidity levels (optional sensor required), number of compressors, blower status, economizer status, filter status, and the number of heating and cooling stages.
- Displays status of the Building Controller including current status of each output, temperature sensor, digital inputs and analog inputs.
- Print and save reports that include schedules, controller alarms and status.
- Alarm e-mail notification (Requires Network Control Panel PC Software to be running and connected to a network and Microsoft Outlook installed and setup for e-mail).
- Data logging and graphing (Requires Network Control Panel PC Software to be running and connected to a network and Microsoft Excel to view data logging reports).

Additional Equipment:

- Network Bus to PC Converter Kit C0MISC47AE1- (96L78) for direct (local) serial COM port connections.
- Network Modem Kit C0MISC46AE1- (94L62) for remote dial-up connections.
- Ethernet Converter Kit C0MISC43AE1L (76M77) for TCP/IP connections.

CD-ROM includes software and L Connection Network controls manuals.

Computer system requirements: IBM compatible PC with Pentium® or higher processor, Microsoft® Windows® 7, 8, 95, 98, Me, 2000, XP, or NT®. (Windows® 7, Windows® 8, Windows® 95, Windows® 98, Windows® Me, Windows® 2000, Windows® XP, and Windows® NT® are registered trademarks of Microsoft Corp.), 256 MB RAM (more memory may be required to run additional applications simultaneously), requires at least 20 MB of free hard drive space, VGA or higher resolution monitor (screen resolution must be 800 X 600 or higher and 256 colors), CD-ROM drive, mouse or compatible pointing device, serial COM port, PC modem for remote connections.

SYSTEM COMPONENTS - SOFTWARE

UNIT CONTROLLER PC SOFTWARE

C0SOFT01AE1- (96L80)



The Unit Controller Software is a Microsoft® Windows® based PC program for interfacing directly with HVAC equipment.

For Lennox' premium rooftop units, the software will interface with the Prodigy® Unit Controller.

For non-Prodigy Lennox units or third-party equipment including rooftop units and split systems, the software will interface with the Network Thermostat Controller DDC module.

This software is required for the following:

- Changes to the control parameters in the Network Thermostat Controller.
- Changes to the control parameters in the Zone Link and Comfort Sensor.

This software will also interface to the Building Controller for configuring building functions and interfacing with the zoning network with Zone Link and Comfort Sensors.

Features and Benefits:

- Allows user the option to set-up, monitor, and diagnose rooftop units from their PC.
- Allows the user to set-up or change the Electronic Configure to Order (ECTO) parameters, view alarm codes, view unit status, test unit and print/save reports.

Additional Equipment:

- Network Bus to PC Converter Kit C0MISC47AE1- (96L78) for direct (local) serial COM port connections.
- Network Modem Kit C0MISC46AE1- (94L62) for remote dial-up connections.
- Ethernet Converter Kit C0MISC43AE1L (76M77) for TCP/IP connections.

CD-ROM includes software and L Connection Network controls manuals.

Computer system requirements: IBM compatible PC with Pentium® or higher processor, Microsoft® Windows® 7, 8, 95, 98, Me, 2000, XP, or NT®. (Windows® 7, Windows® 8, Windows® 95, Windows® 98, Windows® Me, Windows® 2000, Windows® XP, and Windows® NT® are registered trademarks of Microsoft Corp.), 256 MB RAM (more memory may be required to run additional applications simultaneously), requires at least 20 MB of free hard drive space, VGA or higher resolution monitor (screen resolution must be 800 X 600 or higher and 256 colors), CD-ROM drive, mouse or compatible pointing device, serial COM port, PC modem for remote connections.

SYSTEM COMPONENTS - ZONING ACCESSORIES

NETWORK THERMOSTAT CONTROLLER - BYPASS CONTROLLER

C0CTRL70AE1L (11W31)



Network Thermostat Controller Bypass Controller is a proportional and integral (PI) setpoint controller used for controlling the bypass damper for units using the Network Thermostat Controller for CAVB zoning applications. All setup and programming is done by DIP switches and jumpers. Set points may be local and/or remote. The output may be direct- or reverse-acting.

Main Features of Setpoint Controller

- Simple stand-alone operation.
- PI setpoint control.
- Setpoint potentiometer.
- DIP switch/jumper programming.
- Compatible with Damper Actuator C0MISC21AE1L (12W98).
- Compatible with Supply Static Differential Pressure Sensor C0SNSR20AE1 (78M19).

Sequence of Operation

The Network Thermostat Controller Bypass Controller monitors the supply static pressure from the pressure sensor and compares that reading to the supply static pressure setpoints set by using the setpoint potentiometer or setpoint voltage. The controller modulates the bypass damper voltage output to control the unit's supply static pressure based on the controller's PI loop settings.

SPECIFICATIONS - BYPASS CONTROLLER

Operating Environment	Temperature: 32° to 158°F Humidity: 10% - 95% RH, Non-Condensing
Power Requirements	24VAC (+/-10%), 50/60Hz, 3VA (Class 2 transformer required)
Accuracy	+/- 1%
Dimensions	Height: 4-5/8 in. Width: 4-13/16 in. Depth: 2 in.
Weight	0.4 lbs.
INPUTS / OUTPUTS	
Local Set Point input	10K potentiometer
Remote Set Point input	4-20mA, 1-5VDC or 10K potentiometer
Analog Output	4-20mA for controlling bypass damper actuator. Compatible with Damper Actuator C0MISC21AE1L (12W98)
Analog Inputs	1-5VDC for Duct Static Pressure Sensor. Compatible with Supply Static Differential Pressure Sensor C0SNSR20AE1 (78M19)
Cable Type	Analog Output - Two conductor thermostat cable 20AWG min. Analog Input - 2 twisted pair shielded cable (2 Lennox yellow COMM cables): C0MISC00AE1- (27M19) (500 ft. box), C0MISC04AE1- (94L63) (1000 ft. box), C0MISC01AE1- (68M25) (2500 ft. roll)

UCM-420A DIP SWITCH SETTINGS

B3	B4	B5	MUX ADDR	B6	B7	B8	TIME BASE	A6	A7	A8	PROP T.R.																							
0	0	0	1	0	0	0	2.65	0	0	0	10%																							
0	0	1	2	0	0	1	5.2	0	0	1	20%																							
0	1	0	3	0	1	0	12.85	0	1	0	35%																							
0	1	1	4	0	1	1	25.6	0	1	1	50%																							
1	0	0	5	1	X	X	.59-2.93	1	0	0	65%																							
1	0	1	6	<table border="1" style="width: 100%; border-collapse: collapse;"> <thead> <tr> <th>A4</th><th>A5</th><th>RESET PER MIN</th> </tr> </thead> <tbody> <tr> <td>0</td><td>0</td><td>OFF</td> </tr> <tr> <td>0</td><td>1</td><td>0.5</td> </tr> <tr> <td>1</td><td>0</td><td>1</td> </tr> <tr> <td>1</td><td>1</td><td>2</td> </tr> </tbody> </table>			A4	A5	RESET PER MIN	0	0	OFF	0	1	0.5	1	0	1	1	1	2	1	0	1	80%									
A4	A5	RESET PER MIN																																
0	0	OFF																																
0	1	0.5																																
1	0	1																																
1	1	2																																
1	1	0	7	<table border="1" style="width: 100%; border-collapse: collapse;"> <thead> <tr> <th colspan="2">SWITCH OFF</th><th colspan="2">SWITCH ON</th> </tr> </thead> <tbody> <tr> <td>A3</td><td>REVERSE ACTING</td><td colspan="2">DIRECT ACTING</td> </tr> <tr> <td>A2</td><td>BOTH OFF >> REMOTE SEPT</td><td colspan="2">LOCAL SETPT ENABLE</td> </tr> <tr> <td>A1</td><td>SAMPLE AND HOLD MODE</td><td colspan="2">REMOTE SETPT ENABLE</td> </tr> <tr> <td>B1</td><td>BOTH OFF >> ANALOG</td><td colspan="2">PWM REM SETPT SGLE UNIT</td> </tr> <tr> <td>B2</td><td>REMOTESET POINT</td><td colspan="2">PWM REM SETPT MUX MODE</td> </tr> </tbody> </table>			SWITCH OFF		SWITCH ON		A3	REVERSE ACTING	DIRECT ACTING		A2	BOTH OFF >> REMOTE SEPT	LOCAL SETPT ENABLE		A1	SAMPLE AND HOLD MODE	REMOTE SETPT ENABLE		B1	BOTH OFF >> ANALOG	PWM REM SETPT SGLE UNIT		B2	REMOTESET POINT	PWM REM SETPT MUX MODE		1	1	0	90%
SWITCH OFF		SWITCH ON																																
A3	REVERSE ACTING	DIRECT ACTING																																
A2	BOTH OFF >> REMOTE SEPT	LOCAL SETPT ENABLE																																
A1	SAMPLE AND HOLD MODE	REMOTE SETPT ENABLE																																
B1	BOTH OFF >> ANALOG	PWM REM SETPT SGLE UNIT																																
B2	REMOTESET POINT	PWM REM SETPT MUX MODE																																
1	1	1	8	<table border="1" style="width: 100%; border-collapse: collapse;"> <thead> <tr> <th colspan="2">SWITCH OFF</th><th colspan="2">SWITCH ON</th> </tr> </thead> <tbody> <tr> <td>A3</td><td>REVERSE ACTING</td><td colspan="2">DIRECT ACTING</td> </tr> <tr> <td>A2</td><td>BOTH OFF >> REMOTE SEPT</td><td colspan="2">LOCAL SETPT ENABLE</td> </tr> <tr> <td>A1</td><td>SAMPLE AND HOLD MODE</td><td colspan="2">REMOTE SETPT ENABLE</td> </tr> <tr> <td>B1</td><td>BOTH OFF >> ANALOG</td><td colspan="2">PWM REM SETPT SGLE UNIT</td> </tr> <tr> <td>B2</td><td>REMOTESET POINT</td><td colspan="2">PWM REM SETPT MUX MODE</td> </tr> </tbody> </table>			SWITCH OFF		SWITCH ON		A3	REVERSE ACTING	DIRECT ACTING		A2	BOTH OFF >> REMOTE SEPT	LOCAL SETPT ENABLE		A1	SAMPLE AND HOLD MODE	REMOTE SETPT ENABLE		B1	BOTH OFF >> ANALOG	PWM REM SETPT SGLE UNIT		B2	REMOTESET POINT	PWM REM SETPT MUX MODE		1	1	1	100%
SWITCH OFF		SWITCH ON																																
A3	REVERSE ACTING	DIRECT ACTING																																
A2	BOTH OFF >> REMOTE SEPT	LOCAL SETPT ENABLE																																
A1	SAMPLE AND HOLD MODE	REMOTE SETPT ENABLE																																
B1	BOTH OFF >> ANALOG	PWM REM SETPT SGLE UNIT																																
B2	REMOTESET POINT	PWM REM SETPT MUX MODE																																

▲

"1" MEANS
TURN SWITCH ON

▲

"0" MEANS
TURN SWITCH OFF

A

B

STATUS LED

REMOTE SETPOINT
LOCAL SETPOINT
FEEDBACK

1

2

3

4

5

6

7

8

9

10

11

12

<input type="checkbox"/>	PWM INPUT
<input type="checkbox"/>	PWM INPUT
<input type="checkbox"/>	REM SPT INPUT
<input type="checkbox"/>	LOC SPT POT +
<input type="checkbox"/>	LOC SPT INPUT
<input type="checkbox"/>	LOC SPT POT -
<input type="checkbox"/>	FEEDBK INPUT
<input type="checkbox"/>	24 PWR
<input type="checkbox"/>	COMMON
<input type="checkbox"/>	MA SIG OUTPUT

SYSTEM COMPONENTS - ZONING ACCESSORIES

DAMPER ACTUATOR **COMISC21AE1L (12W98)**

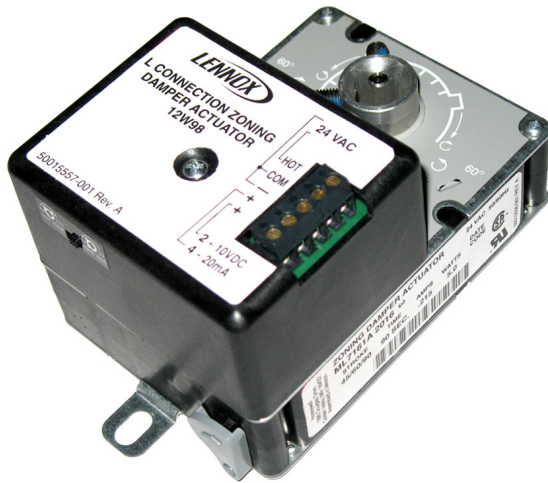

The Damper Actuator is used for zone damper and bypass damper control. The modulating actuator is controlled by a 2-10VDC or 4-20mA input. The actuator requires 24VAC for power.

Main Features of the Damper Actuator

- Used for all damper sizes, both zone and unit bypass dampers.
- Used for all bypass dampers.
- Mounts to Lennox dampers with one screw.
- Provided with 2-10VDC and 4-20mA control inputs.
- Screw field wiring terminal block.

SPECIFICATIONS - DAMPER ACTUATOR

Unit Controller Compatibility	Prodigy® Unit Controller - All versions (requires optional VAV Module Kit)
Units Without Prodigy® Unit Controller	Network Thermostat Controller Bypass Controller required
Operating Environment	Temperature: 20° to 125°F Humidity: 10% - 95% RH, non- condensing
Power Requirements	24VAC (+/-20%), 50/60Hz, 4.8VA (class 2 transformer required)
Torque	35 in./lbs.
Stroke	Selectable 45°, 60° and 90°
Rotation	Clockwise and counter-clockwise
Stroke Time	90 Seconds for 90°
Dimensions	Height: 4-7/8 in. Width: 3-3/8 in. Depth: 2-7/8 in
Weight	1.6 lbs.
INPUTS / OUTPUTS	
Analog Inputs	2-20VDC 4-20mA
Approvals	UL: 873 Plenum rated Canadian UL: cUL C22.2 No. 24-93 CE: 89/336/ECC, 73/23/ECC C-Tick: N314

DAMPER ACTUATOR - FIELD WIRING

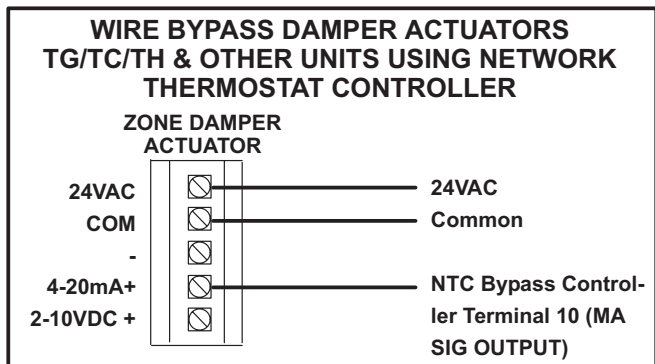
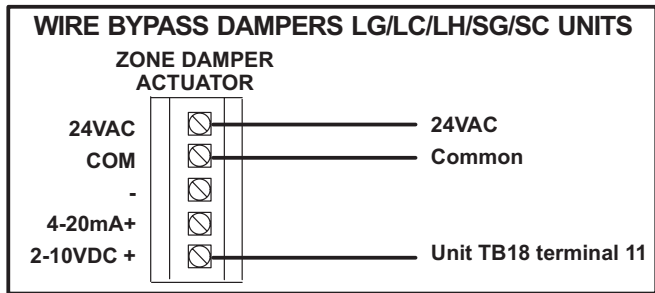
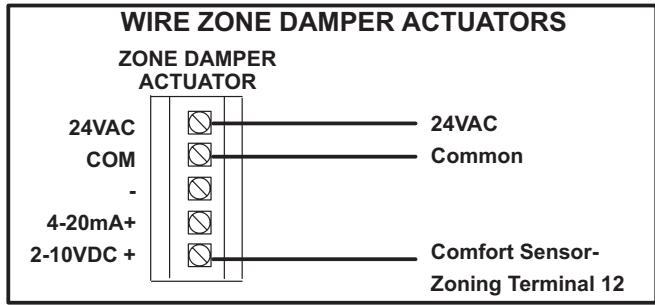
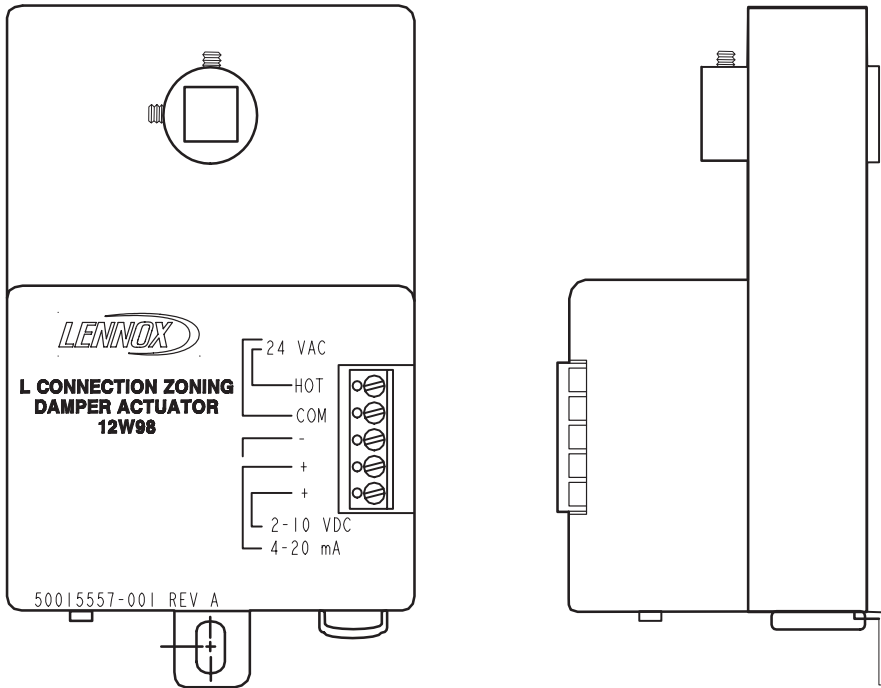

SYSTEM COMPONENTS - ZONING ACCESSORIES

ZONE AND BYPASS DAMPERS

ROUND DAMPER SHELL

FEATURES:

- GALVANIZED STEEL CONSTRUCTION
- DUCT: 24ga
- DAMPER BLADE: 20ga
- DRIVE MOTOR MOUNTING BRACKET: 16ga

- DAMPER SHIPPED WITH BLADE IN OPEN POSITION FOR ZONE DAMPER
- CLOSE BLADE PRIOR TO MOUNTING BYPASS DAMPER ACTUATOR

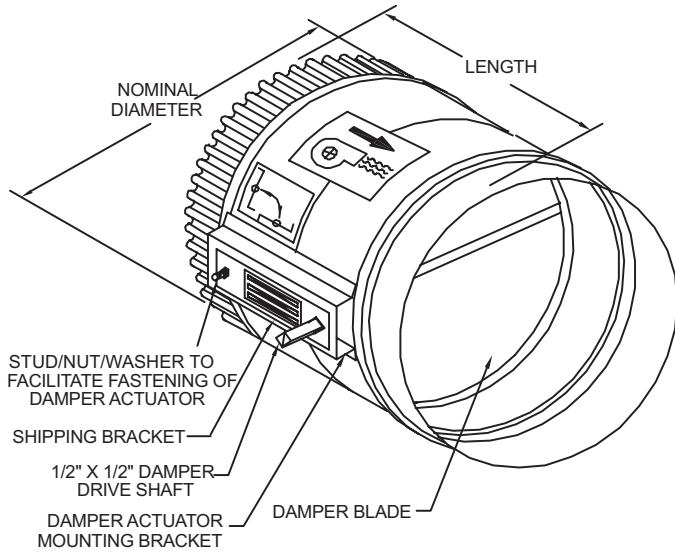

RECTANGULAR DAMPER SHELL

FEATURES:

- GALVANIZED STEEL CONSTRUCTION
- STAINLESS STEEL SIDE SEALS
- DRIVE MOTOR MOUNTING BRACKET

- DAMPER SHIPPED WITH BLADES IN OPEN POSITION FOR ZONE DAMPER
- CLOSE BLADES PRIOR TO MOUNTING BYPASS DAMPER ACTUATOR

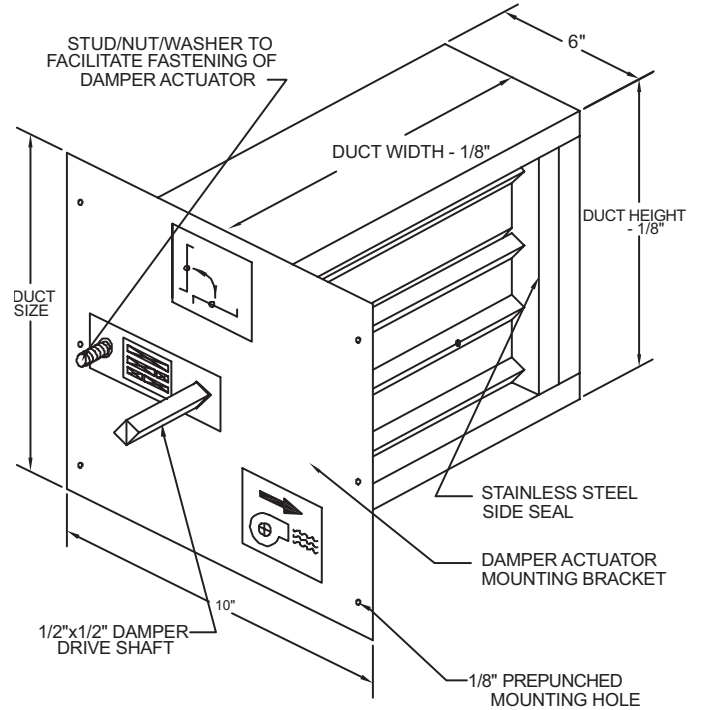

SYSTEM COMPONENTS - ZONING ACCESSORIES

ZONE AND BYPASS DAMPERS (continued)

ROUND DAMPER SHELLS

Catalog No.	Diameter (in.)	Length (in.)
21M90	6	12
21M91	7	13
21M92	8	13
21M93	9	14
21M94	10	14
21M95	11	14
21M96	12	14
21M97	14	17
21M98	16	17
34M44	18	17

RECTANGULAR DAMPER SHELLS

Catalog No.	Width (in.)	Height (in.)
22M02	8	10
22M03	8	12
22M04	8	14
22M05	8	16
22M06	8	18
22M07	8	20
22M08	8	22
22M09	8	24
22M10	8	26
22M11	8	28
22M12	8	30
22M13	10	8
22M14	10	10
22M15	10	12
22M17	10	16
22M18	10	18
22M19	10	20
22M20	10	22
22M21	10	24
22M22	10	26
22M23	10	28
22M24	10	30
22M25	12	8
22M26	12	10
22M27	12	12
22M28	12	14
22M30	12	18

RECTANGULAR DAMPER SHELLS

Catalog No.	Width (in.)	Height (in.)
22M31	12	20
22M32	12	22
22M33	12	24
22M34	12	26
22M35	12	28
22M36	12	30
22M38	14	10
22M39	14	12
22M40	14	14
22M41	14	16
22M42	14	18
22M43	14	20
22M44	14	22
22M45	14	24
22M46	14	26
22M47	14	28
22M48	14	30
22M49	16	8
22M52	16	14
22M54	16	18
22M56	16	22
22M57	16	24
22M58	16	26
22M59	16	28
22M60	16	30
22M61	18	8
22M62	18	10
22M63	18	12
22M67	18	20
22M68	18	22
22M69	18	24
22M70	18	26
22M71	18	28
22M72	18	30
22M73	20	8
22M74	20	10
22M75	20	12
22M76	20	14
22M79	20	20
22M81	20	24

SYSTEM COMPONENTS - ZONING ACCESSORIES

ZONE AND BYPASS DAMPERS (CONTINUED)

RECTANGULAR DAMPER SHELLS

Catalog No.	Width (in.)	Height (in.)
22M82	20	26
22M84	20	30
22M85	22	8
22M86	22	10
22M88	22	14
22M89	22	16
22M92	24	8
22M93	24	10
22M94	24	12
22M96	24	16
22M97	24	18
22M99	26	8
23M00	26	10
23M01	26	12
23M02	26	14
23M03	26	16
23M05	26	20
23M06	28	8
23M07	28	10
23M08	28	12
23M09	28	14
23M10	28	16
23M12	28	20
23M13	30	8
23M14	30	10
23M15	30	12
23M16	30	14
23M18	30	18
23M19	30	20
30M68	32	8
30M86	32	12
30M95	32	14
31M04	32	16
31M22	32	20

RECTANGULAR DAMPER SHELLS

Catalog No.	Width (in.)	Height (in.)
30M87	34	12
30M70	36	8
30M97	36	14
30M80	38	10
30M89	38	12
30M90	40	12
30M73	42	8
31M21	48	18

SYSTEM COMPONENTS - MISCELLANEOUS ACCESSORIES

AFTER-HOURS OVERRIDE BUTTON

C0SWCH20AE1- (56L16)

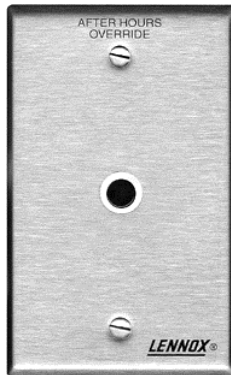

Momentary pushbutton used for after-hours override. Mainly used with applications that use the return air duct mount zone sensor. It can also be used with any non-communicating zone sensor for remote after-hours pushbutton applications.

Main Features of After-Hours Override Button

- Single gang electrical handy box size.
- Stainless steel wall mounting plate.
- Simple two wire connection to any non-communicating zone sensor. (Wires in parallel to sensor, to momentarily short sensor).

SPECIFICATIONS - AFTER-HOURS OVERRIDE BUTTON

Sensor Compatibility	C0SNAJ01AW1- (56L80) Zone Sensor - Wall-Mount w/ Adjustment C0SNZN07AE1- (94L60) Zone Sensor - Wall-Mount C0SNDC02AE1- (56L81) Zone Sensor - Return Air Duct Mount C0SNZN08AE1- (94L61) Zone Sensor - Miniature Wall-Mount C0SNZN04AE1- (76M32) Zone Sensor - Flush Wall-Mount
Button Type	Momentary - Normally open
Cover Material	Stainless steel
Dimensions	Height: 4-1/2 in. Width: 2-3/4 in. Depth: 1/8 in.
Weight	0.2 lbs.
Cable Type	Two-conductor thermostat wire, 20 AWG min.

SYSTEM COMPONENTS - MISCELLANEOUS ACCESSORIES

BLOWER AIRFLOW PROVING SWITCH KIT

C0SWCH01AE1- (30K49)

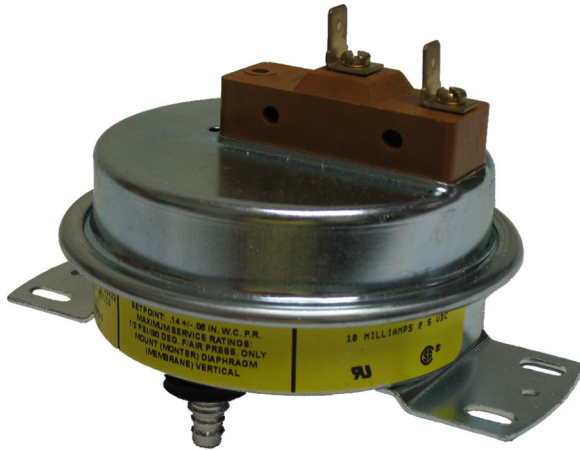

Network Thermostat Controller Applications

When used with Network Thermostat Controller unit controller applications, this switch allows the use of the blower proving input. This allows the information to be displayed at the Network Control Panel and software program display screens and will shut down the unit if the airflow is lost. Simple plug-in connection.

Building Controller Applications

When used on Building Controller applications, the switch is used to display the information at the Network Control Panel and software program display screens and to override an output. Simple plug-in connection.

Lennox' Premium Rooftop Unit Applications

When used on Lennox' premium rooftop unit applications, this switch allows the use of the blower proving input. This allows the alarm code to be displayed on the Prodigy® Unit Controller, the Network Control Panel and software program display screens. The unit will shut down if airflow is lost. Simple plug-in connection.

SPECIFICATIONS - BLOWER PROVING AIRFLOW SWITCH KIT

Operating Temperature	-40°F To 190°F
Electrical Switch Type	Single pole, normally open, snap action
Electrical Ratings	10mA @5VDC
Electrical Connections	1/4 in. quick connect terminals
Contact Material	Gold alloy
Operating Pressure	Normally open contacts close on pressure rise at 0.14 (± 0.05) in. w.c. (non-adjustable)
Usage	Air only
Maximum Pressure	0.5 psi
Expected Life	100,000 Cycles
Mounting Position	Recommended diaphragm vertical
Mounting	4 Mounting Holes
Sample Line Connector	Positive: Combination barbed type for use with 1/4 in. or 5/16 in. I.D. flexible plastic or rubber tubing
Dimensions	Height: 4-5/8 in. Width: 3-9/16 in. Depth: 3-1/8 in.
Weight	0.5 lbs.
Cable Type	Two-conductor thermostat wire, 20 AWG min.

SYSTEM COMPONENTS - MISCELLANEOUS ACCESSORIES

DIRTY FILTER SWITCH KIT

C0SWCH00AE1- (30K48)

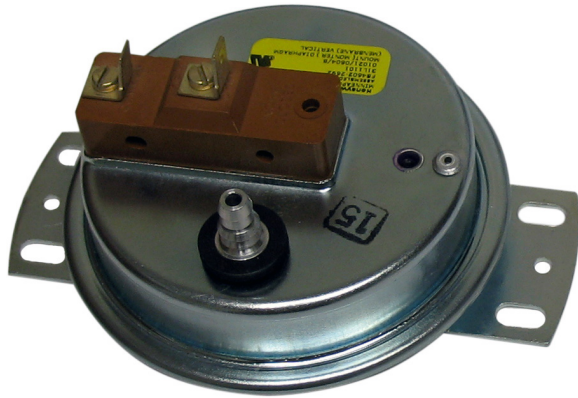

Network Thermostat Controller Applications

When used with Network Thermostat Controller applications, switch allows the use of the dirty filter input that will issue a dirty filter alarm. Simple plug-in connection.

Building Controller Applications

When used on Building Controller applications, switch is used to display the information at the Network Control Panel and software program display screens and to override an output. Simple plug-in connection.

Lennox' Premium Rooftop Unit Applications

When used on Lennox' premium rooftop unit applications, switch allows the use of the dirty filter input. This allows the alarm code to be displayed on the Prodigy® Unit Controller, the Network Control Panel and software program display screens. Simple plug-in connection.

SPECIFICATIONS - DIRTY FILTER SWITCH KIT

Operating Temperature	-40°F To 190°F
Electrical Switch Type	Single pole, normally open, snap action
Electrical Ratings	10mA @5VDC
Electrical Connections	1/4 in. quick connect terminals
Contact Material	Gold alloy
Operating Pressure	Normally open contacts close on pressure rise at 1.0 in. w.c. (± 0.10) (non-adjustable)
Usage	Air only
Maximum Pressure	0.5 psi
Expected Life	100,000 cycles
Mounting Position	Recommended diaphragm vertical
Mounting	Mounting bracket furnished for installation in rooftop unit
Sample Line Connector	Negative: Combination barbed type for use with 1/4 in. or 5/16 in. I.D. flexible plastic or rubber tubing
Dimensions	Height: 4-5/8 in. Width: 3-9/16 in. Depth: 3-1/8 in.
Weight	0.5 lbs.
Cable Type	Two-conductor thermostat wire, 20 AWG min.

SYSTEM COMPONENTS - MISCELLANEOUS ACCESSORIES

DUCT PRESSURE LIMIT SWITCH

C0SNSR11AE1 (79M80)



The Duct Pressure Limit Switch is used to shut down the variable frequency drive (VFD) on a variable air volume (VAV) application if the switch's pressure setpoint is reached. A Mounting Kit C0SNSR12AE1 (79M81) is also available that includes 18 in. of vinyl tubing, tubing adapters and mounting flange with screws.

Main Features of Duct Pressure Limit Switch

- Compatible with Lennox premium rooftop VAV units.
- Adjustable setpoint.

SPECIFICATIONS - DUCT PRESSURE LIMIT SWITCH

Operating Temperature	-30°F To 180°F
Electrical Switch Type	Single-pole double-throw
Electrical Ratings	15 Amps @120-480VAC , derate to 10 Amps for high cycle rates
Electrical Connections	Screw-type terminals
Pressure Limits	45 in. w.c. continuous, 10 psig surge
Setpoint Adjustment	Screw-type inside conduit enclosure
Deadband	Approximately 0.30 in. w.c.
Operating Pressure Range	1.4 to 5.5 in. w.c..
Usage	Air only
Mounting Position	Diaphragm in vertical position
Mounting	Two mounting holes
Sample Line Connectors	Low pressure and high pressure - 1/8 in. female NPT
Dimensions	Height: 3-1/2 in. Width: 3-1/2 in. Depth: 2-3/8 in.
Weight	1 lbs.
Cable Type	Two-conductor thermostat wire, 20 AWG min.
Agency	CE

ACCESSORY

Mounting Kit for Duct Pressure Limit Kit	C0SNSR12AE1 (79M81) - Includes 18 in. of vinyl tubing, tubing adapters and mounting flange with screws
---	--

SYSTEM COMPONENTS - MISCELLANEOUS ACCESSORIES

PRESSURE SWITCH

C0SNSR10AE1 (79M79)



Static pressure switch used to control unit power exhaust fans on Lennox' premium rooftop unit applications using one of the Prodigy® Unit Controller's staged exhaust fan options.

SPECIFICATIONS - PRESSURE SWITCH

Operating Temperature	40°F To 190°F
Electrical Switch Type	Single-pole single-throw, automatic reset
Electrical Ratings	10mA @5VDC
Contact Material	Gold-flash
Electrical Connections	Screw-type terminals
Pressure Limits	13.85 in. w.c.
Setpoint Range	0.05 to 12 in. w.c.
Setpoint Adjustment	Screw-type inside conduit enclosure
Operating Pressure Range	1.4 to 5.5 in. w.c.
Usage	Air only
Mounting Position	Diaphragm in vertical position
Mounting	Two mounting holes
Sample Line Connectors	Compression fittings for 1/4 in. O.D. rigid or semi-rigid tubing, barb fittings for 1/4 in. O.D. polyethylene tubing
Dimensions	Height: 5-9/16 in. Width: 6 in. Depth: 3-1/8 in.
Weight	1.3 lbs.
Cable Type	Two-conductor thermostat wire, 20 AWG min.
Agency	UL and CSA

SYSTEM COMPONENTS - MISCELLANEOUS ACCESSORIES

OUTDOOR AIR WEATHER-HEAD

C0SNSR22AE1- (79M21)



The Outdoor Air Weather-Head effectively reduces the fluctuation of outdoor static pressures caused by wind gusts. Eliminating this fluctuation is necessary in the control of building pressures which use outdoor static pressure as a reference.

Main Features of Outdoor Air Weather Head

- Includes 50 ft. of vinyl tubing, weather-head, mounting bracket and hardware.
- Adjustable bracket for horizontal or vertical mounting.
- Used with C0SNSR21AE1- (78M20) Return (Building) Static Differential Pressure Sensor.

SPECIFICATIONS - OUTDOOR AIR WEATHER HEAD

Tubing Length	50 ft.
Tubing Size	1/8 in. ID
Tubing Material	Vinyl

SYSTEM COMPONENTS - MISCELLANEOUS ACCESSORIES

PLUG-IN 24V TRANSFORMER

COMISC30AE1- (18M13)



20VA wall plug 120VAC to 24VAC transformer.

Main Features of Plug-In Transformer

- 120VAC primary.
- 24VAC (20VA) secondary.
- Screw terminal 24VAC output.
- Black plastic enclosure.

SPECIFICATIONS - PLUG-IN 24V TRANSFORMER

Primary Voltage	120VAC , 60HZ
Secondary Voltage	24VAC, 20VA maximum, Class 2
Secondary Terminals	Two #6-32 screw terminals
Overload Protection	Energy limited
Dimensions	Height: 3 in. Width: 2-1/2 in. Depth: 2 in.
Weight	1 lbs.
Agency	UL 1310 & CSA listed

SYSTEM COMPONENTS - MISCELLANEOUS ACCESSORIES

TRANSFORMER

COMISC32AE1- (75VA) (27W14), COMISC33AE1- (100VA) (27W15)

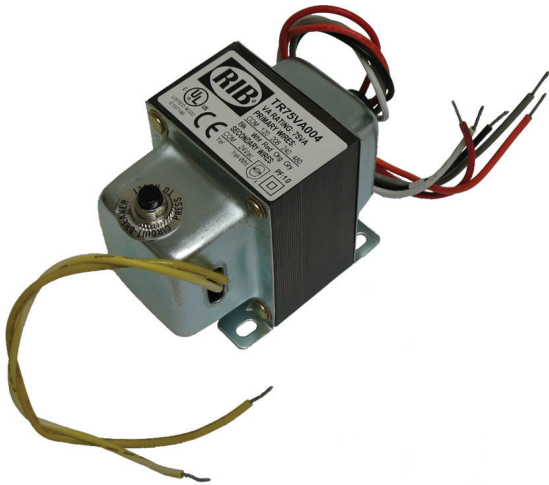

75VA, 24VAC control transformer has primary taps for 120, 208, 240 and 480VAC.

100VA, 24VAC control transformer has primary taps for 120, 240, 277 and 480VAC.

Main Features of Transformer

- Plate or panel mounted.
- 9 in. leads.
- 1/2 in. 14 NPSM conduit connector.
- Circuit breaker overload protection.

SPECIFICATIONS - TRANSFORMER

Model No.	COMISC32AE1- (75VA)	COMISC33AE1- (100VA)
Operating Temperature	-20°F to 105°F	-20°F to 105°F
Primary Voltage	120, 208 or 240 VAC, 60HZ	120, 240, 277 or 480 VAC, 60HZ
Secondary Voltage	24VAC, 75VA, Class 2	24VAC, 100VA, Class 2
Lead Wire Length	9 in.	9 in.
Lead Wire Size	18AWG	18AWG
Overload Protection	3.5 Amp circuit breaker , manual reset	3.5 Amp circuit breaker , manual reset
Dimensions	Height: 3 in. Width: 2-1/2 in. Length: 3-15/16 in. (w/ 1/2 in. NPT hub)	Height: 3 in. Width: 2-1/2 in. Length: 4-1/4 in. (w/ 1/2 in. NPT hub)
Weight	4 lbs.	4.5 lbs.
Agency	Meets UL standard UL 1585 for Class 2 not wet, Class 3 wet, UL listed file # E14881 guide # XOKV CSA Certified, CSA file LR95329-18 Meets NEC Class 2 requirements	Meets UL standard UL 1585 for Class 2 not wet, Class 3 wet, UL listed file # E14881 guide # XOKV CSA Certified, CSA file LR95329-18 Meets NEC Class 2 requirements

TRANSFORMER - FIELD WIRING

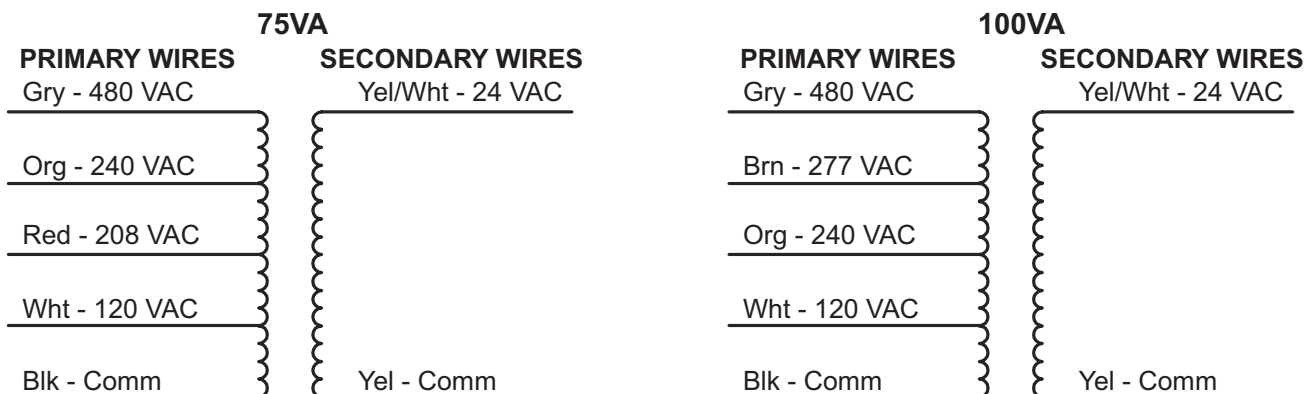

NETWORK CONTROL PANEL SERVICE PACK 8

C0SOFT50AE1- (26W28)



Firmware upgrade for the Network Control Panel. It requires a PC with a serial port, CD-ROM disk drive and Windows® 95 to XP. Kit includes CD and cable.

NOTE - This upgrade is required for use in zoning applications if an existing Network Control Panel is used.

Main Features of Network Control Panel Service Pack

- Cable plugs directly from Network Control Panel to PC serial port.
- Updates Network Control Panel to firmware version 2.01.

SYSTEM COMPONENTS - NEMA ENCLOSURES

NEMA 4 HINGED ENCLOSURE

COMISC10AE1- (17M11)



The NEMA 4 Hinged Enclosure is an optional enclosure that is available for the Network Thermostat Controller, Building Controller or Zone Link.

Features and Specifications

- Continuous hinge, clamped cover.
- Body and cover formed from 16-gauge steel.
- Includes inner panel with pre-drilled holes to match the Network Thermostat Controller mounting plate.
- Three knockouts on bottom for conduit connections.
- Complies with NEMA type 3R, 4.4X, 12 and 13.
- Finished with smooth ANSI/ASA 61 gray powder coating.
- Dimensions (H x W x D) - 12 x 10 x 5 in.
- Weight - 15 lbs.

NEMA 1 HINGED ENCLOSURE

COMISC14AE1 - (34M24)



The NEMA 1 Hinged Enclosure is an optional enclosure that is available for the Network Control Panel and Network Modem Kit or Ethernet Converter Kit for indoor mounting.

Features and Specifications

- Body and cover formed from 16-gauge steel.
- Includes inner panel with pre-drilled holes to match the Network Control Panel mounting plate.
- Includes hook-and-loop strips for mounting of modem.
- Three knockouts on bottom for conduit connections.
- Finished with smooth white paint.
- Dimensions (H x W x D) - 14 x 12 x 4 in.
- Weight - 14.7 lbs.

NEMA 1 HINGED ENCLOSURE

COMISC13AE1 - (34M23)



The NEMA 1 Hinged Enclosure is an optional enclosure that is available for the Network Thermostat Controller, Zone Link, Building Controller or the Network Modem Kit and Phone Line Auto-Router for indoor mounting.

Features and Specifications

- Body and cover formed from 16-gauge steel.
- Includes inner panel with pre-drilled holes to match the Network Thermostat Controller and Building Controller mounting plate.
- Includes hook-and-loop fasteners for mounting of modem and auto-router.
- Finished with smooth white paint.
- Dimensions (H x W x D) - 12 x 10 x 4 in.
- Weight - 11.5 lbs.

SYSTEM COMPONENTS - ORDERING INFORMATION

Description	Model No.	Order No.	Page No.
CONTROLLERS			
Building Controller	C0CTRL80AE1L	17M12	page 27
Network Control Panel	C0CTRL10AE1L	59L21	page 13
Network Thermostat Controller	C0CTRL07AE1L	17M10	page 23
I/O Module Kit	C0CTRL10AE1L	86M39	page 21
VAV Module Kit	C0CTRL02AE1L	86M71	page 19
NETWORK			
Ethernet Converter Kit	C0MISC43AE1L	76M77	page 69
Network Bus to PC Converter	C0MISC47AE1-	96L78	page 66
Network Modem Kit	C0MISC46AE1-	94L62	page 67
Network Repeater	C0CTRL51AE1L	11W30	page 63
Phone Line Auto-Router	C0MISC41AE1-	34M22	page 68
Service Tube Kit	- - -	59W52	page 70
Surge Protector	C0MISC92AE1-	23W22	page 65
NETWORK CABLE			
SysBus			
SysBus Cable - 500 ft. Box (Yellow Jacket)	C0MISC00AE1-	27M19	page 71
SysBus Cable - 1000 ft. Box (Yellow Jacket)	C0MISC04AE1-	94L63	page 71
SysBus Cable - 2500 ft. Roll (Yellow Jacket)	C0MISC01AE1-	68M25	page 71
ZoneBus			
ZoneBus Cable - 500 ft. Box (Purple Jacket)	C0MISC05AE1-	23W99	page 71
ZoneBus Cable - 1000 ft. Box (Purple Jacket)	C0MISC06AE1-	24W00	page 71
ZoneBus Cable - 2500 ft. Roll (Purple Jacket)	C0MISC07AE1-	24W01	page 71
SENSORS			
Comfort Sensors - With Display and Setpoint Adjustment			
Temperature, Display, Setpoint/Fan Control, After Hours Override	C0SNAJ02AE1L	18W68	page 34
Temperature, Relative Humidity, Display, Setpoint/Fan Control, After Hours Override	C0SNMT10AE1L	18W66	page 34
Temperature, CO ₂ , Display, Setpoint/Fan Control, After Hours Override	C0SNMT20AE1L	18W67	page 34
Temperature, Relative Humidity, CO ₂ , Display, Setpoint/Fan Control, After Hours Override	C0SNMT30AE1L	18W65	page 34
Comfort Sensors - No Display or Setpoint Adjustment			
Temperature, After Hours Override	C0SNZN09AE1-	18W72	page 34
Temperature, Relative Humidity, After Hours Override	C0SNMT11AE1-	18W69	page 34
Temperature, CO ₂ , After Hours Override	C0SNMT21AE1L	18W70	page 34
Temperature, Relative Humidity, CO ₂ , After Hours Override	C0SNMT31AE1L	18W71	page 34
Comfort Sensors For Zoning - With Display and Setpoint Adjustment			
Temperature, Display, Setpoint/Fan Control, After Hours Override, Zone Damper, Fan and Heat Control	C0SNCT01AE1L	18W58	page 40
Temperature, Relative Humidity, Display, Setpoint/Fan Control, After Hours Override, Zone Damper, Fan and Heat Control	C0SNCT10AE1L	18W56	page 40
Temperature, CO ₂ , Display, Setpoint/Fan Control, After Hours Override, Zone Damper, Fan and Heat Control	C0SNCT20AE1L	18W57	page 40
Temperature, Relative Humidity, CO ₂ , Display, Setpoint/Fan Control, After Hours Override, Zone Damper, Fan and Heat Control	C0SNCT30AE1L	18W55	page 40
Comfort Sensors For Zoning - No Display or Setpoint Adjustment			
Temperature, After Hours Override, Zone Damper, Fan and Heat Control	C0SNCT00AE1L	18W59	page 40
Temperature, Relative Humidity, After Hours Override, Zone Damper, Fan and Heat Control	C0SNCT11AE1L	18W60	page 40
Temperature, CO ₂ , After Hours Override, Zone Damper, Fan and Heat Control	C0SNCT21AE1L	18W61	page 40
Temperature, Relative Humidity, CO ₂ , After Hours Override, Zone Damper, Fan and Heat Control	C0SNCT31AE1L	18W62	page 40

SYSTEM COMPONENTS - ORDERING INFORMATION

Description	Model No.	Order No.	Page No.
SENSORS (continued)			
CO₂ Sensors - Non-Communicating			
Wall-Mount - Off-White Plastic Cover, No Display	C0SNSR52AE1L	87N53	page 50
Wall-Mount - Off-White Plastic Cover With LCD Display	C0SNSR50AE1L	77N39	page 50
Wall-Mount - Black Plastic Case, No Display	C0SNSR53AE1L	87N54	page 50
Wall-Mount - Black Plastic Case With LCD Display	C0SNSR51AE1L	87N52	page 50
Aspiration Box For Duct Mounting CO ₂ Sensors	C0MISC16AE1-	90N43	page 52
CO ₂ Downflow Duct Mounting Kit	C0MISC19AE1-	85L43	page 50
Duct Temperature Sensor			
12 in. Probe	C0SNDC04AE1-	99K64	page 58
Outdoor Air Control Sensor Kit			
Includes I/O Module	C0SNSR23DE1-	98M61	page 56
Outdoor Temperature Sensor			
Water-Proof Wiring Junction Box, Vented Aluminum Cover	C0SNSR02AE1-	59M05	page 57
Relative Humidity Sensors - Non-Communicating			
Wall-Mount - Off-White Plastic Case	C0SNSR31AE1-	17M50	page 53
Return Air Duct Mount	C0SNSR30AE1-	76M31	page 54
Remote Discharge Sensor			
Remote Discharge Temperature Kit - Includes 22 ft. of Cable	C1SNSR75AD1	58W63	page 55
Return (Building) Static Differential Pressure Sensor			
Three Operating Ranges, Three Output Options	C0SNSR21AE1-	78M20	page 61
Supply Static Differential Pressure Sensor			
Three Operating Ranges, Three Output Options	C0SNSR20AE1	78M19	page 60
Temperature Sensor Probe			
General Purpose 3 in. Sensor	C0SNSR05AE1-	14K92	page 59
Zone Sensors - Non-Communicating			
Wall-Mount - With Warmer/Cooler Setpoint Adjustment	C0SNAJ01AE1-	56L80	page 45
Wall-Mount - No Adjustment	C0SNZN07AE1-	94L60	page 45
Wall-Mount - Miniature	C0SNZN08AE1-	94L61	page 46
Wall-Mount - Miniature, For use with Building Controller	C0SNZN03AE1-	59M04	page 46
Wall-Mount - Averaging Sensor Kit (Two Sensors)	C0SNZN71AE1-	23M20	page 48
Wall-Mount - Flush	C0SNZN04AE1-	76M32	page 49
Return Air Duct Mount	C0SNDC02AE1-	56L81	page 47
Ambient Light Sensor			
Automatic Lighting Control	C0SNSR60AE1-	34M67	page 62
NEMA ENCLOSURES			
NEMA 1 - Hinged, For Network Thermostat Controller, Building Controller, Zone Link or Network Modem Kit and Auto-Router	C0MISC14AE1-	34M24	page 90
NEMA 1 - Hinged, For Network Control Panel, Network Modem Kit and Ethernet Converter Kit	C0MISC13AE1-	34M23	page 90
NEMA 4 - Hinged, For Network Thermostat Controller, Building Controller or Zone Link	C0MISC10AE1-	17M11	page 90
SOFTWARE			
Network Control Panel PC Software	C0SOFT11AE1-	96L82	page 72
Unit Controller PC Software	C0SOFT01AE1-	96L80	page 73
ZONING / NETWORK EXPANDER			
Zone Link	C0CTRL11AE1L	11W27	page 30
ZONING			
Zone and Bypass Dampers	See Pages page 78 - page 80		
ZONING ACCESSORIES			
Damper Actuator	C0MISC21AE1L	12W98	page 76
Network Thermostat Controller - Bypass Controller	C0CTRL70AE1L	11W31	page 74

SYSTEM COMPONENTS - ORDERING INFORMATION

Description	Model No.	Order No.	Page No.
MISCELLANEOUS ACCESSORIES			
After-Hours Override Button	C0SWCH20AE1-	56L16	page 81
Blower Airflow Proving Switch Kit	C0SWCH01AE1-	30K49	page 82
Dirty Filter Switch	C0SWCH00AE1-	30K48	page 83
Duct Pressure Limit Switch	C0SNSR11AE1	79M80	page 84
Mounting Kit for Duct Pressure Limit Switch - 18 in. vinyl tubing and connectors	C0SNSR12AE1	79M81	page 84
Network Control Panel Service Pack	C0SOFT50AE1-	26W28	page 89
Outdoor Air Weather-Head	C0SNSR22AE1-	79M21	page 86
Pressure Switch	C0SNSR10AE1	79M79	page 85
Transformer - 120, 208, 240 and 480VAC, 60HZ Primary / 24VAC Secondary, 75VA	C0MISC32AE1-	27W14	page 88
Transformer - 120, 240, 277 and 480VAC, 60HZ Primary / 24VAC Secondary, 100VA	C0MISC33AE1-	27W15	page 88
Transformer - 24V, Plug-in	C0MISC30AE1-	18M13	page 87

REVISIONS

Sections	Description of Change
System Overview	Revised System Overview Network illustration to better define SysBUS and ZoneBUS.
System Selection Flowcharts	Updated System Component Selection Example - Basic Overview and Component Selection Example - Basic Overview to better define SysBUS and ZoneBUS.



Visit us at www.lennox.com

For the latest technical information, www.lennoxcommercial.com

Contact us at 1-800-4-LENNOX

NOTE - Due to Lennox' ongoing commitment to quality, Specifications, Ratings and Dimensions subject to change without notice and without incurring liability. Improper installation, adjustment, alteration, service or maintenance can cause property damage or personal injury. Installation and service must be performed by a qualified installer and servicing agency.

©2013 Lennox Industries, Inc.