



ENGINEERING DATA

LG
L SERIES® ROOFTOP UNITS
60 HZ

Bulletin No. 210317
August 2008
Supersedes July 2007



ASHRAE 90.1
COMPLIANT



7.5 to 12.5 Tons
Net Cooling Capacity - 90,000 to 140,000 Btuh
Gas Input Heat Capacity - 130,000 to 240,000 Btuh

MODEL NUMBER IDENTIFICATION

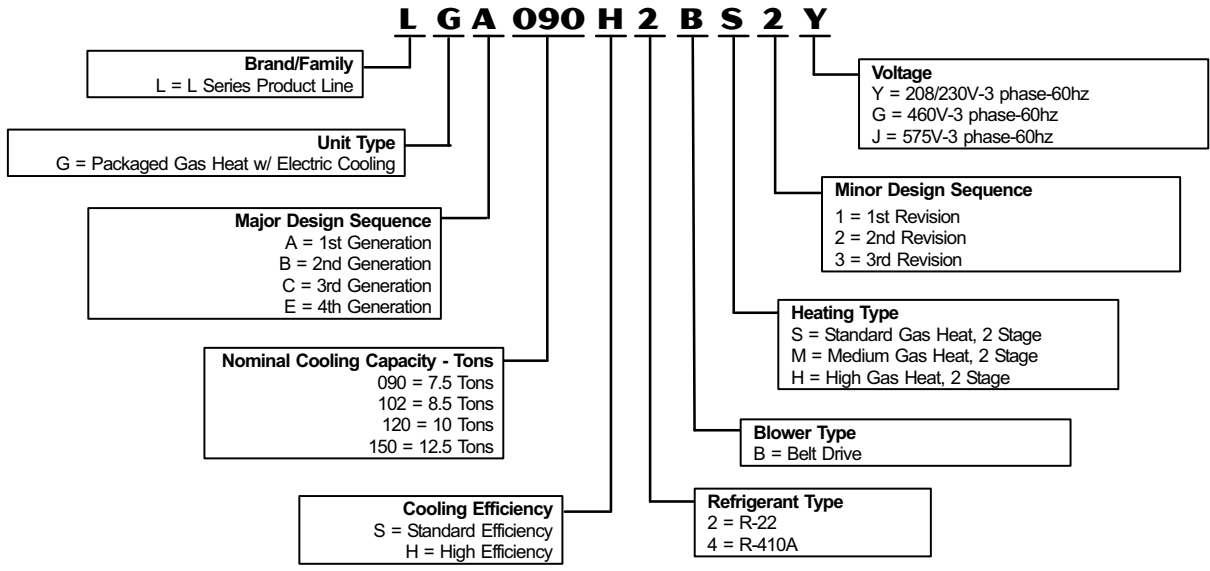

CONTENTS

Accessory Air Resistance	Page 24
Application Guide	Pages 53-55
Blower Performance	Pages 23-25
Cooling Ratings	Pages 13-18
Dimensions	Pages 38-43
Electrical Data	Pages 26-29
Features and Benefits	Pages 2-6
Guide Specifications	Pages 45-52
High Altitude Information	Page 13
Humiditrol® Condenser Reheat Option	Page 7
Humiditrol® Condenser Reheat Ratings	Pages 19-22
Model Number Identification	Page 1
Options / Accessories	Pages 6-10
Specifications	Pages 11-12
Sound Data	Page 30
System Controller / Unit Controllers	Pages 31-36
Unit Clearances	Page 30
Weights	Page 37

FEATURES AND BENEFITS

APPROVALS

ETL and CSA listed.

Efficiency rating verified by CSA.

Components bonded for grounding to meet safety standards for servicing required by UL, CSA and National and Canadian Electrical Codes.

Certified in accordance with the ULE certification program, which is based on ARI Standard 340/360-2004.

ASHRAE 90.1 compliant.

ENERGY STAR® certified units are designed to use less energy, help save money on utility bills, and help protect the environment.

The ENERGY STAR® Partner of the Year Award signifies that Lennox has made outstanding contributions to design energy efficient units that will lower energy bills, while meeting industry standards for comfort and indoor air quality. Lennox was the first HVAC manufacturer to win this award and has been a four-time recipient since 2003. ISO 9001 Registered Manufacturing Quality System.

Dealer Design Award

Lennox has received the Dealer Design Award from an independent panel of dealer-contractors selected by Air Conditioning, Heating & Refrigeration News ("The News") magazine. Their decision is based on "best in categories" of installation, maintenance and service as well as quality and performance.

WARRANTY

Limited ten years aluminized heat exchanger, limited fifteen years optional stainless steel heat exchanger.

Limited five years on compressors.

Limited three years on Integrated Modular Control.

Limited one year all other covered components.

CABINET

Construction

Heavy-gauge steel panels and full perimeter heavy-gauge galvanized steel base rail provides structural integrity for transportation, handling, and installation.

- 1 Base rails have rigging holes. Three sides of the base rail have fork slots. Raised edges around duct and power entry openings in the bottom of the unit provide additional protection against water entering the building.

Air-Flow Choice

Units are available in down-flow (vertical) or horizontal air flow configuration.

Duct Flanges

Horizontal supply duct flange is standard on all units.

- 2 Power/Gas Entry

Electrical and gas lines can be brought through the unit base or through horizontal access knock-outs.

- 3 Exterior Panels

Constructed of heavy-gauge, galvanized steel with a two-layer enamel paint finish.

- 4 Insulation

All panels adjacent to conditioned air are fully insulated with non-hygroscopic fiberglass insulation.

- 5 Unit base is fully insulated. The insulation also serves as an air seal to the roof curb, eliminating the need to add a seal during installation.

- 6 Access Panels

Hinged access panels are provided for the economizer/filter section, blower/heating section and the compressor/controls section.

All panels have seals and quarter-turn latching handles to provide a tight air and water seal.

REQUIRED SELECTIONS

Air Flow Configuration

Specify horizontal or down-flow.

OPTIONS/ACCESSORIES

Factory Installed

Corrosion Protection

Polymeric epoxy coating that is deposited by electrical transport (electrophoresis), using a process known as electrocoat (e-coat). Available for enhanced coil corrosion protection. Factory installed on the condenser coil, evaporator coil, or both.

Field Installed

Coil Guards

Painted, galvanized steel wire guards to protect outdoor coil. Not used with Hail Guards.

Grille Guards

Protects space between outdoor coils and main cabinet.

Hail Guards

Constructed of heavy gauge steel, painted to match cabinet, helps protect outdoor coils from hail damage. Not used with Coil Guards.

Horizontal Conversion Kit

Two piece duct cover in kit blocks off unit down flow supply air opening, horizontal return air opening panel (on unit) is moved to block off down flow return air opening for horizontal applications.

FEATURES AND BENEFITS

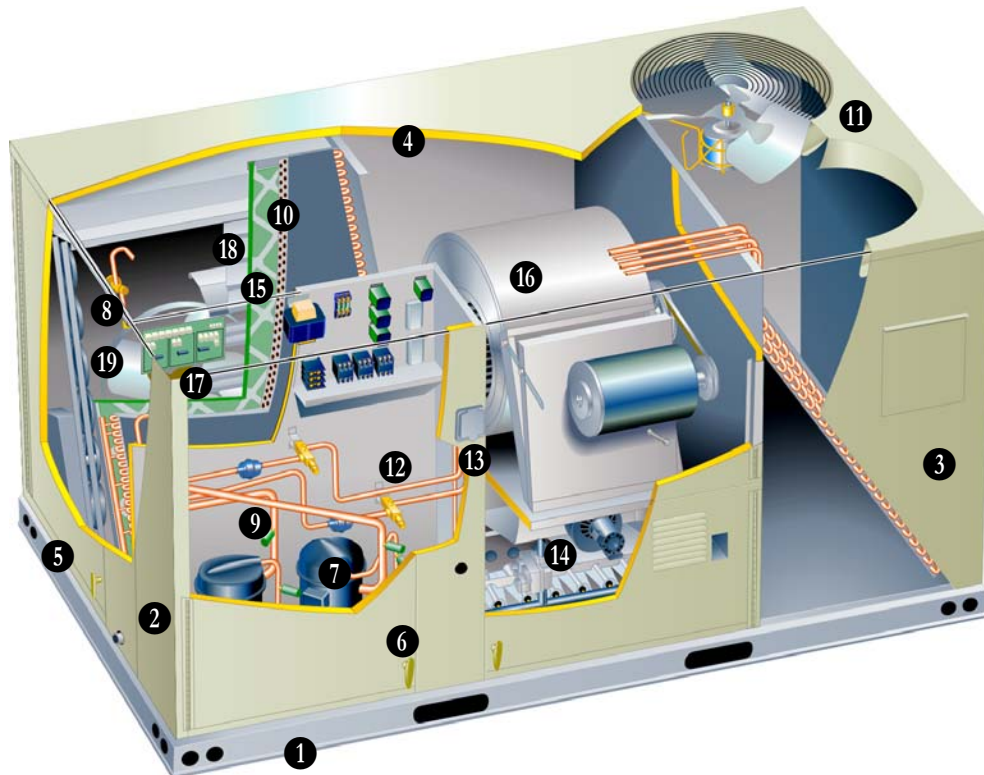

COOLING SYSTEM

Designed to maximize sensible and latent cooling performance at design conditions. Two efficiency levels provide flexibility. System can operate from 0°F to 125°F without any additional controls.

7 Compressors

Resiliently mounted on rubber grommets for quiet operation. Scroll compressors on all models for high performance, reliability and quiet operation.

Compressor Crankcase Heaters

Protects against refrigerant migration that can occur during low ambient operation.

8 Thermal Expansion Valves

Assures optimal performance throughout the application range. Removable element head.

Filter/Driers

High capacity filter/drier protects the system from dirt and moisture.

9 High Pressure Switches

Protects the compressor from overload conditions such as dirty condenser coils, blocked refrigerant flow, or loss of outdoor fan operation.

Low Pressure Switches

Protects the compressor from low pressure conditions such as low refrigerant charge, or low/no air flow.

Freezestats

Protects the evaporator coil from damaging ice build-up due to conditions such as low/no air flow, or low/no refrigerant charge.

10 Coil Construction

Copper tube construction, enhanced rippled-edge aluminum fins, flared shoulder tubing connections, silver soldered construction for improved heat transfer. Factory leak tested.

Evaporator Coil

Face split with separate circuits. Cross row circuiting optimizes both sensible and latent cooling capacity.

Condenser Coil

Slab type on all models.

Condensate Drain Pan

Painted, galvanized pan with positive slope. Drain connection extends outside unit.

11 Outdoor Coil Fan Motors

Thermal overload protected, totally enclosed, permanently lubricated ball bearings, shaft up, wire basket mount.

Outdoor Coil Fans

PVC coated fan guard furnished.

REQUIRED SELECTIONS

Cooling Capacity

Specify the nominal cooling capacity of the unit.

Cooling Efficiency

Specify either standard or high efficiency.

Refrigerant Choice

Specify R-22 or R410A refrigerant.

OPTIONS/ACCESSORIES

Factory Installed

12 Service Valves

Fully serviceable brass valves installed in discharge and liquid lines.

Factory or Field Installed

Condensate Drain Trap

Field installed only, may be factory enclosed to ship with unit. Available in copper or PVC.

ELECTRICAL

REQUIRED SELECTIONS

Voltage Choice

Specify when ordering base unit.

OPTIONS/ACCESSORIES

Factory Installed

Circuit Breakers

HACR circuit breaker without power distribution lugs. Accessible from outside of unit, spring-loaded weatherproof cover furnished. Main power to the unit is field connected to the circuit breaker which allows all power to be shutoff for service. Circuit breaker is sized to the unit maximum overcurrent protection (MOCP) size.

Phase Monitor

Protects unit against premature equipment failure caused by phase loss, phase reversal, phase unbalance, under voltage and overvoltage.

Factory or Field Installed

13 Disconnect Switch

Accessible from outside of unit, spring loaded weatherproof cover furnished.

GFI Service Outlets (2)

115v ground fault circuit interrupter (GFCI) type, field wired.

FEATURES AND BENEFITS

HEATING SYSTEM

- 14 Aluminized steel inshot burners, direct spark ignition, electronic flame sensor, combustion air inducer, redundant automatic dual stage gas valve with manual shut-off.

Fan & Limit Controls

Factory installed, limit controls with fixed temperature setting.

Heat limit controls protect against overheating.

Safety Switches

Flame roll-out switches, flame sensor switches and combustion air inducer proving switches protect system operation.

All safety switches are monitored by the IMC unit controller and diagnostic errors are reported and recorded.

Heat Exchanger

Tubular construction, aluminized steel, life cycle tested.

Stainless Steel Heat Exchanger is required if mixed air temperature is below 45°F (7°C).

REQUIRED SELECTIONS

Gas Input - Order one:

84,500/130,000 Btuh Standard Heat Gas Input

117,000/180,000 Btuh Medium Heat Gas Input

156,000/240,000 Btuh High Heat Gas Input

OPTIONS/ACCESSORIES

Factory Installed

Low Temperature Vestibule Heater

Electric heater automatically controls minimum temperature in gas burner compartment when temperature is below -40°F. C.G.A. certified to allow operation of unit down to -60°F.

Stainless Steel Heat Exchanger

Required if mixed air temperature is below 45 °F.

Factory or Field Installed

Field Installed

Combustion Air Intake Extensions

Recommended for use with existing flue extension kits in areas where high snow drifts can block intake air

LPG/Propane Kit

Conversion kit to field changeover units from Natural Gas to LPG/Propane.

Vertical Vent Extension Kit

For high snow areas or when vent is too close to fresh air intake.

INDOOR AIR QUALITY

Air Filters

Disposable 2 inch pleated MERV 7 filters (Minimum Efficiency Reporting Value based on ASHRAE 52.2).

OPTIONS/ACCESSORIES

Factory or Field Installed

15 High Efficiency Air Filters

Disposable 2 inch pleated MERV 11 filters (Minimum Efficiency Reporting Value based on ASHRAE 52.2). See Options/Accessories tables for ordering information.

Field Installed

Healthy Climate® UVC Germicidal Lamps



Germicidal lamps emit ultra-violet (UV-C) energy, which has been proven to be effective in reducing microbes such as viruses, bacteria, yeasts, and molds. This process either destroys the organism or controls its ability to reproduce.

UV-C energy greatly reduces the growth and proliferation of mold and other bioaerosols (bacteria and viruses) on illuminated surfaces (particularly coil and drain pan).

Lamps are field installed in the blower/evaporator coil section.

All necessary hardware for installation is included.

Lamps operate on 208/230V power supply. Step-down transformer furnished on models used with 460V and 575V rooftop units.

Magnetic safety interlock terminates power when access panels are removed. Approved by ETL.

Indoor Air Quality (CO₂) Sensor

Monitors CO₂ levels, reports to IMC board which adjusts economizer dampers as needed.

16 BLOWER

A wide selection of supply air blower options are available to meet a variety of air flow requirements.

Motor

Overload protected, equipped with ball bearings.

Belt drive motors are offered on all models and are available in several different sizes to maximize air performance.

Motor Efficiency

Specify standard or high efficiency.

Supply Air Blower

Overload protected, belt drive motors.

Forward curved blades, double inlet, blower wheel is statically and dynamically balanced, ball bearings, adjustable pulley (allows speed change), blower assembly slides out of unit for servicing.

Ordering Information

Specify motor horsepower and drive kit number when base unit is ordered.

See Blower Data table for specifications.

REQUIRED SELECTIONS

Supply Air Blower

Order Standard or High Efficiency Blower motor (See Blower Data Table for specifications).

Order one drive kit, see Drive Kit Specifications Table.

SERVICEABILITY

Designed to streamline general maintenance and decrease troubleshooting time.

Diagnostics

IMC diagnostic codes pinpoint problems, minimizing troubleshooting time.

Marked & Color-Coded Wiring

All electrical wiring is color-coded and marked to identify which components it is connecting.

Electrical Plugs

Positive connection electrical plugs are used to connect common accessories or maintenance parts for easy removal or installation.

Toolless, Hinged Access Panels

Large access panels are hinged and have quarter-turn, latching handles for quick and easy access to maintenance areas.

Blower Access

Blower assembly slides out of the unit for easy access.

Thermal Expansion Valves

Thermal expansion valves are located near the perimeter of the unit for easier access.

Removable element head allows change out of element and bulb without removing the TXV.

Coil Cleaning

Slab coils allow for easy cleaning. Doors at each end of the coil compartment allow access to clean coils from the inside.

Standard Components

A large number of common maintenance parts are standard throughout the entire range of sizes (3-30 tons), reducing the need to carry a lot of different parts to the job or in inventory.

Compressor Compartment

Compressors are located near the perimeter of the unit for easier access. Compressors are isolated from the condenser air flow allowing system operation checks to be done without changing the air flow across the outdoor coils.

Service Valves (optional)

Optional factory installed liquid and discharge service valves allow refrigerant to be isolated to the high side for service work on the low side of the refrigeration system.

CONTROLS

17 INTELLIGENT UNIT CONTROLLER

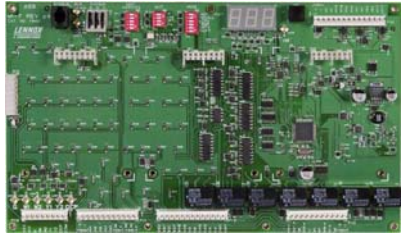

The Integrated Modular Controller (IMC) is a solid-state microprocessor-based control board that provides flexible control of all unit functions.

All control voltage is provided via a 24V (secondary) transformer with built-in circuit breaker protection.

Built-in functions include:

Blower On/Off Delay - Adjustable time delay between blower on and off.

Built-in Control Parameter Defaults - No programming required.

Compressor Time-Off Delay - Adjustable time delay between compressor shutoff and start up.

DDC Compatible - Various third party DDC controllers can be factory or field installed. Refer to the Unit Controllers section for details.

Dirty Filter Switch Input - When a Dirty Filter Switch is installed, the IMC will signal when the indoor blower static pressure increases, indicating a dirty filter condition. Switch is optional and can be factory or field installed.

Discharge Air Temperature Control - The IMC will cycle up to 4 stages of heating or cooling to maintain the discharge air setpoints for heating or cooling. Optional sensor for remote field installation in the supply duct.

Display/Sensor Readout - Displays control parameters, diagnostic codes, and sensor readings. The IMC unit controller displays temperature readings from return air, supply air, and outdoor air sensors that are furnished as standard on all L Series units. IMC will also display readings from optional sensors such as zone sensors, CO₂ sensors or relative humidity sensors.

Economizer Control Choice - The economizer is controlled by an add-on board to the IMC. The economizer control board has several choices for controlling the economizer. See Economizer / Outdoor Air / Exhaust Options.

Fresh Air Tempering - Provides heating and cooling as needed to maintain the supply air temperature within a comfort range, regardless of the thermostat demand. Sensor ships with unit but must be field installed in the supply air duct. Requires change to IMC (ECTO) parameter in the field to activate this mode of operation.

Extensive Unit Diagnostics - The IMC monitors all sensors and functions related to unit operation to provide critical information. The IMC will display detailed diagnostic information with over 90 diagnostic codes to pinpoint any problems and reduce troubleshooting time. All diagnostic codes are listed inside control access panel for easy reference.

Exhaust Fan Control Modes - Fans controlled by fresh air damper position or building static differential pressure transducer.

Permanent Diagnostic Code Storage - Maintains diagnostic codes through a power failure.

Field Changeable Control Parameters - Over 200 different control parameters allow customization of the unit operation by changing delays, cooling stages, deadbands, and setpoints.

Indoor Air Quality Input - The IMC is Demand Control Ventilation ready from the factory (optional field installed CO₂ sensor required). Two modes of operation are available: setpoint and proportional.

1 - Setpoint - Opens the economizer dampers to full position when CO₂ setpoint level is reached.

2 - Proportional - Opens the dampers at the first set point and gradually increases it as the CO₂ level increases until the second setpoint is reached.

Low Ambient Controls - Allows unit cooling operation down to 0°F.

Gas Valve Time Delay Between First and Second Stage - Allows gradual increase of input rate.

Minimum Compressor Run Time - Ensures proper oil return to the compressor.

Network Capable - The IMC can be daisy chained to other L Series units or L Connection[®] Network controllers using twisted pair wire.

Night Setback Mode - Adjusts setpoints, closes outdoor air dampers and operates the blower on demand, may be customized for special requirements.

Return Air Temperature Limit Control - Allows the user to override the demands based upon the return air temperature during either heating or cooling operation. Helps protect against abnormal operating conditions in the event of a room sensor or thermostat failure.

Safety Switch Input - Normally-closed digital input allows the IMC to respond to a external safety switch trip (phase protector, low voltage, etc.) shutting down unit operation.

Service Relay Output - Digital output can indicate a critical error has occurred to an external control device. Can also be configured to energize based on relative humidity, indoor air quality, outdoor air temperature or unit operation.

Smoke Alarm Mode - Control board has four choices for responding to a smoke alarm.

1 - Unit Off - unit will turn off.

2 - Positive Pressure - blower is energized, exhaust fan is de-energized, and the outdoor air dampers are opened.

3 - Negative Pressure - blower is energized, exhaust fan is energized, and the outdoor air dampers are closed.

4 - Purge - blower is energized, exhaust fan is energized, and the outdoor air dampers are opened.

Staging - 2 heat/2 cool. Capable of up to 4 heat/4 cool with zone sensor or third party DDC control system.

“Strike Three” Protection - Ends cooling or heating operation when any of the following occurs three times (adjustable) within a thermostat cycle: low pressure trip, high pressure trip, heat limit trip, or freeze-stat trip.

Gas Reheat - Control parameter option that allows simultaneous heating and cooling operation for controlling humidity for process air applications such as supermarkets. Field installed relative humidity sensor or dehumidistat can be used.

On-Demand Dehumidification - Monitors and controls condenser reheat operation with Humiditrol option. Prioritizes heat and cool demand with dehumidification demand. Reheat demand can be enabled by digital input or a field installed relative humidity sensor can be used.

Thermostat Bounce Delay - Protects compressor from short cycling when mechanical thermostat is used.

Warm-up Mode Delay - Adjustable time that the economizer dampers are kept in the closed position during morning warm-up.

On-Board User Interface - Push-button, DIP switches used with three-digit display readout for field adjustment of control parameters. LED indicators for L Connection Network (transmit and receive) and for each thermostat input.

PC Interface - PC with optional Unit Controller software may be used to field or remotely adjust parameters, read alarms, or display unit status.

Zone Sensor Operation - Controls zone temperature with up to 4 stages of heating or cooling with optional zone sensor.

FEATURES AND BENEFITS

CONTROLS - CONT.

OPTIONS / ACCESSORIES

Factory or Field Installed

Blower Proving Switch

Monitors blower operation, shuts down unit if blower fails. Factory installed.

Dirty Filter Switch

Senses static pressure increase indicating dirty filter condition.

Fresh Air Tempering

Used in applications with high outside air requirements. The IMC energizes the first stage heat as needed to maintain a minimum supply air temperature for comfort, regardless of the thermostat demand. When ordered as a factory option, the sensor ships with the unit but must be field installed.

Smoke Detector

Photoelectric type, installed in supply air section or return air section or both sections

Interoperability via BACnet® or LonTalk® Protocols

Communication compatible with third-party automation systems that support the BACnet Application Specific Controller device profile, LonMark® Space Comfort Controller functional profile, or LonMark Discharge Air Controller functional profile. See Page 32.

Commercial Control Systems

L Connection® Network

Complete building automation control system for single or multi-zone applications. Options include local interface, software for local or remote communication, and hardware for networking other control functions. See L Connection Network Engineering Handbook Bulletin for details.

Aftermarket DDC

Novar® Unit Controller and options. See Page 31.

Thermostats

Control system and thermostat options. Aftermarket unit controller options. See See Page 36.

Field Installed

Humidity Sensor Kit, Remote Mounted
Humidity sensor required with factory installed Humiditrol™ Option or Supermarket reheat field selectable option.

OPTIONS / ACCESSORIES

ECONOMIZER/OUTDOOR AIR/EXHAUST OPTIONS

Factory or Field Installed

18 Economizer

Parallel gear driven action return air and outdoor air dampers, plug-in connections to unit, nylon bearings, neoprene seals, 24 volt fully modulating spring return motor, adjustable minimum damper position, damper assembly slides in unit, outdoor air hood must be ordered separately, optional down-flow barometric relief dampers available, choice of economizer controls. The IMC add-on board for economizer control is included with the economizer. Control board has four choices for controlling the economizer (DIP switch selections).

1 - Differential Sensible Control

Factory setting. Uses outdoor air and return air sensors that are furnished with the unit. The IMC compares outdoor air and return air and using setpoints, enables the economizer when the outdoor air temperature is below the configured setpoint and cooler than return air.

NOTE - Differential Sensible Control can be configured in the field to provide Offset Differential Sensible Control or Single Sensible Control.

In Offset Differential Sensible Control mode, the economizer is enabled if the temperature differential (offset) between outdoor air and return air reaches the configured setpoint.

In Single Sensible Control mode, the economizer is enabled when outdoor air temperature falls below the configured setpoint.

2 - Global Control

The IMC communicates with a DDC system with one global sensor (enthalpy or sensible) to determine whether outside air is suitable for free cooling on all units connected to the control system. Sensor must be field provided.

3 - Single Enthalpy Control - Outdoor air enthalpy sensor enables economizer if the outdoor enthalpy is less than the setpoint of the board. Factory installed.

4 - Differential Enthalpy Control

Two solid-state enthalpy sensors allow the economizer control board to select between outdoor air or return air, whichever has lower enthalpy. Factory installed.

Down-Flow Barometric Relief Dampers

Allows relief of excess air, aluminum blade dampers prevent blow back and outdoor air infiltration during off cycle, bird screen furnished, see Field Installed section (below) for damper hood

Outdoor Air Damper Section

Linked mechanical dampers, 0 to 25% (fixed) outdoor air adjustable, installs in unit, outdoor air hood must be ordered separately. Motorized model features fully modulating spring return damper motor with plug-in connection. Manual model features a slide damper.

Minimum mixed air temperature in heating mode 30°F.

Maximum mixed air temperature in cooling mode: 90°F.

Outdoor Air Hood

Required with LAREMD Economizer, LAOAD and LAOADM Outdoor Air Damper Sections, two cleanable aluminum mesh fresh air filter furnished.

19 Power Exhaust Fan

Installs external to unit for down-flow applications only with economizer option, provides exhaust air pressure relief, interlocked to run when supply air blower is operating, fan runs when outdoor air dampers are 50% open (adjustable), motor is overload protected, steel cabinet and hood painted to match unit. Fan is 20 in. (508 mm) in diameter with 5 fan blades. Total

air volume is 4200 cfm (1980 L/s) at 0 in. wg. (0 Pa). 1/3 hp (249 W) motor. 300 Watts total input.

Field Installed

Down-Flow Barometric Relief Damper Hood

Field installed only.

Horizontal Barometric Relief Dampers

Allows relief of excess air, aluminum blade dampers prevent blow back and outdoor air infiltration during off cycle, field installed in return air duct, bird screen and hood furnished, two dampers per order number.

CEILING DIFFUSERS

Ceiling Diffusers (Flush or Step-Down)

Aluminum grilles, large center grille, insulated diffuser box with flanges, hanging rings furnished, interior transition (even air flow), internally sealed (prevents recirculation), adapts to T-bar ceiling grids or plaster ceilings.

Transitions (Supply and Return)

Used with diffusers, installs in roof curb, galvanized steel construction, flanges furnished for duct connection to diffusers, fully insulated.

ROOF CURBS

Roof Curb, Down-Flow

Nailer strip furnished, mates to unit, US National Roofing Contractors Approved, shipped knocked down.

Cliplock curbs use interlocking tabs to fasten together. No tools required. Available in 8, 14, 18 and 24 inch heights.

Standard roof curb corners fasten together with furnished hardware. Available in 14 and 24 inch heights.

HUMIDITROL® CONDENSER REHEAT OPTION

Factory installed option designed to control humidity.

Provides dehumidification on demand using ASHRAE 90.1 recommended method for reheat with comfort conditioning humidity control.

In addition to a thermostat or room sensor used for conventional operation, a humidity sensor is required and must be located in the occupied space. Remote Mounted Humidity Sensor Kit is required for field installation.

The humidity sensor provides input to the Integrated Modular Control which is used to control activation of the dehumidification operation.

Reheat controls are located in the compressor control section of the unit for easy access.

Benefits

Improves indoor air quality.

Helps prevent damage due to high humidity levels.

Improves comfort levels by reducing space humidity levels.

OPERATION

No Dehumidification Demand - The unit will operate conventionally whenever there is a demand for cooling or heating and no dehumidification demand.

Free cooling is only permitted when there is no demand for dehumidification.

Dehumidification Demand Only - The IMC is factory set at 60% relative humidity setpoint and can be adjusted at the IMC or with optional Unit Controller Software.

For L Connection® Network Control Panel (NCP) applications, the humidity setpoint can be adjusted at the NCP.

The unit will operate in the dehumidification mode until the relative humidity of the conditioned space is 3% below the setpoint.

Reheat operation will initiate on a dehumidification demand and does not require a cooling demand.

The reheat coil is sized to offset most of the 1st stage sensible cooling effect during reheat only operation. This reduces sensible cooling capacity and extends compressor run time to control humidity when the cooling load is low.

A solenoid valve diverts hot gas from the compressor to the reheat coil.

The cooled and dehumidified air from the evaporator is reheated as it passes through the reheat coil.

The de-superheated and partially condensed refrigerant continues to the outdoor condenser coil where condensing is completed. The unit will continue to operate in this mode until the dehumidification demand is satisfied.

A heating demand will terminate reheat operation.

Dehumidification and Cooling Demand (Thermostat/Room Sensor Application)

- If both a dehumidification and a first stage cooling demand occur, the system will operate compressor 1 in reheat and compressor 2 in cooling. A demand for 2nd stage cooling will terminate compressor 1 reheat operation and will then operate compressor 1 and compressor 2 in cooling until 2nd stage cooling demand is satisfied.

ACCESSORIES

Field Installed

Humidity Sensor Kit, Remote Mounted

Humidity sensor required with factory installed Humiditrol™ Option or Supermarket reheat field selectable option.

HUMIDITROL REFRIGERANT SCHEMATIC

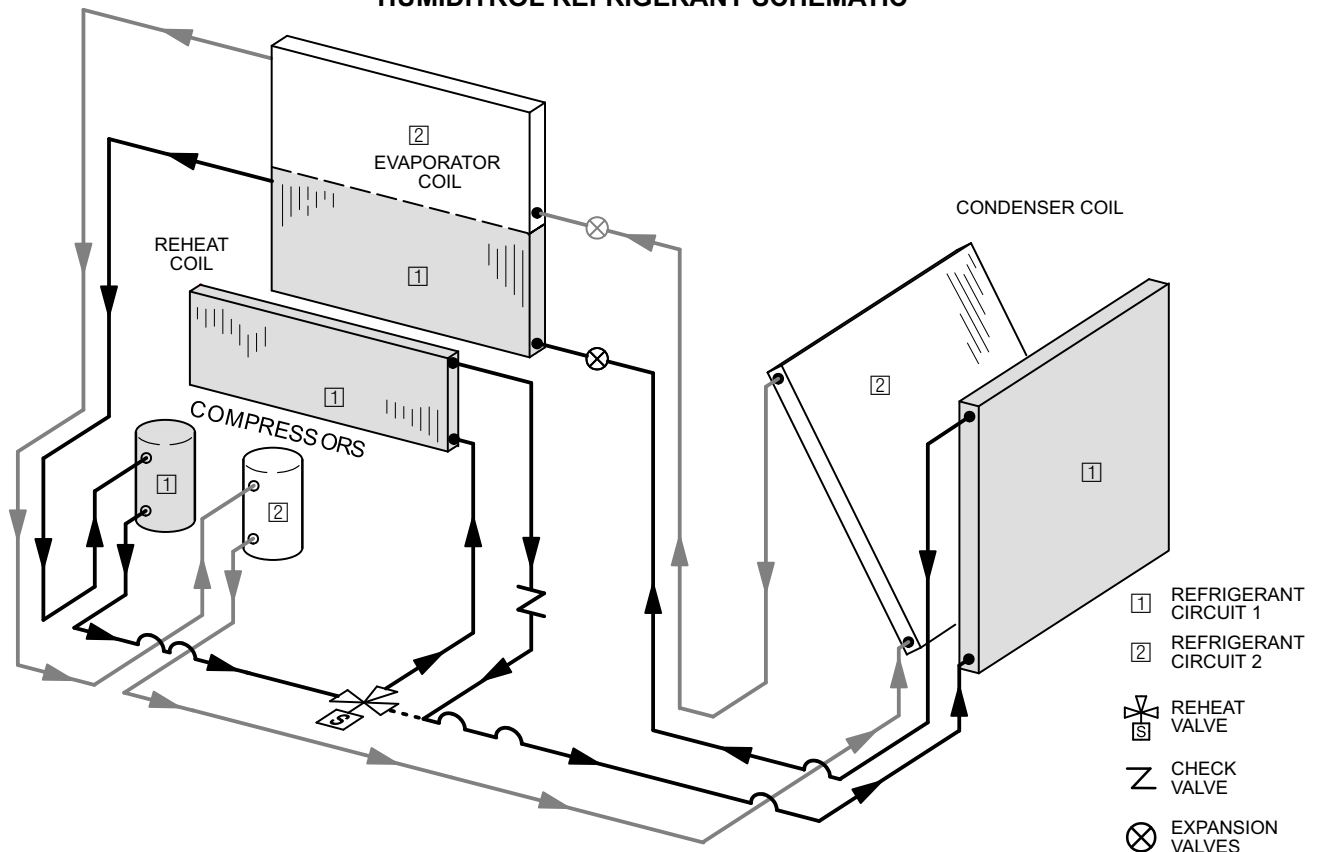

OPTIONS / ACCESSORIES

Item	Catalog No.	090	102	120	150	
COOLING SYSTEM						
Condensate Drain Trap	Copper - LTACDKC09/36	76M19	⊗	⊗	⊗	⊗
	PVC - LTACDKP09/36	76M18	⊗	⊗	⊗	⊗
Corrosion Protection	Factory	○	○	○	○	
Efficiency	Standard	Factory	○	○	○	○
	High	Factory	○	○	○	○
Refrigerant Type	R-22	Factory	○	○	○	○
	R-410A	Factory	○	○	○	○
Service Valves	Factory	○	○	○	○	
Stainless Steel Condensate Drain Pan	Factory	○	○	○	○	
HEATING SYSTEM						
Combustion Air Intake Extensions	LTACA1K10/15	89L97	x	x	x	x
Gas Heat Input (2 Stage)	Standard - 130 kBtuh input	Factory	○	○	○	○
	Medium - 180 kBtuh input	Factory	○	○	○	○
	High - 240 kBtuh input	Factory	○	○	○	○
Low Temperature Vestibule Heater	Factory	○	○	○	○	
LPG/Propane Conversion Kits	130 kBtuh input - LTALPGK-130	72M94	x	x	x	x
	180 kBtuh input - LTALPGK-180	72M95	x	x	x	x
	240 kBtuh input - LTALPGK-240	72M96	x	x	x	x
Stainless Steel Heat Exchanger	Factory	○	○	○	○	
Vertical Vent Extension	LTAWEK10/15	73M72	x	x	x	x
BLOWER - SUPPLY AIR						
Constant Air Volume	2 hp Standard or High Efficiency	Factory	○	○	○	○
	3 hp Standard or High Efficiency	Factory	○	○	○	○
	5 hp Standard or High Efficiency	Factory	○	○	○	○
CABINET						
Coil Guards		88K51	x	x	x	x
Grille Guards		86K29	x	x	x	x
Hail Guards		88K24	x	x	x	x
Horizontal Discharge Conversion Kit	LTHSDKGC10/15	56K53	x	x	x	x
CONTROLS						
Blower Proving Switch	C0SWCH01AE1-	30K49	⊗	⊗	⊗	⊗
Commercial Controls	L Connection® Building Automation System	- - -	⊗	⊗	⊗	⊗
	Novar® ETM-2051 Unit Controller	71M58	⊗	⊗	⊗	⊗
Dirty Filter Switch	C0SWCH00AE1-	30K48	⊗	⊗	⊗	⊗
Fresh Air Tempering	C0SNDC03AE-1	45L78	⊗	⊗	⊗	⊗
Smoke Detector - Supply	LTSASDK10/36	70K87	⊗	⊗	⊗	⊗
Smoke Detector - Return	LTARSDK10/30	70K86	⊗	⊗	⊗	⊗
ELECTRICAL						
Voltage 60 hz	208/230V - 3 phase	Factory	○	○	○	○
	460V - 3 phase	Factory	○	○	○	○
	575V - 3 phase	Factory	○	○	○	○
HACR Circuit Breakers	Factory	○	○	○	○	
Disconnect Switch	80 Amp	84M13	⊗	⊗	⊗	⊗
GFI Service Outlets	LTAGFIK10/15	74M70	⊗	⊗	⊗	⊗
Phase Monitor	Factory		○	○	○	○

NOTE - The catalog and model numbers that appear here are for ordering field installed accessories only.

⊗ - Field Installed or Configure to Order (factory installed)

○ - Configure to Order (Factory Installed)

X - Field Installed.

OPTIONS / ACCESSORIES

Item	Catalog No.	090	102	120	150
HUMIDITROL® CONDENSER REHEAT OPTION					
Humiditrol	Factory	H	H	H	S
Humidity Sensor Kit, Remote Mounted (required)	C0SNSR13AE-1 17M50	x	x	x	x
Remote Sensor Wall Seal Plate	C0MISC18AE-1 58L33	x	x	x	x
INDOOR AIR QUALITY					
Air Filters					
High Efficiency Air Filter 18 x 24 x 2 - Order 4 per unit	MERV 11 - C1FLTR20B-1- 97L86	⊗	⊗	⊗	⊗
Germicidal Lamps					
Healthy Climate® UVC Germicidal Lamps	208/230V - C1UVCL10B-1Y X7521	x	x	x	x
	460V - C1UVCL10B-1G X7526	x	x	x	x
	575V - C1UVCL10B-1J X7531	x	x	x	x
Indoor Air Quality Sensors					
CO ₂ Sensor - off-white case w/ display	C0SNSR50AE1L 77N39	x	x	x	x
CO ₂ Sensor - off-white case, no display	C0SNSR52AE1L 87N53	x	x	x	x
CO ₂ Sensor - black case w/ display	C0SNSR51AE1L 87N52	x	x	x	x
CO ₂ Sensor - black case, no display	C0SNSR53AE1L 87N54	x	x	x	x
CO ₂ Sensor Duct Mounting Kit	LTIAQSDMK03/36 85L43	x	x	x	x
Aspiration Box for duct mounting Sensor	C0MISC16AE1- 90N43	x	x	x	x
Handheld CO ₂ Monitor	LTIAQSHM03/36 70N93	x	x	x	x
ECONOMIZER					
Economizer					
Economizer - Order Hood Separately	LAREMD10/15 53K51	⊗	⊗	⊗	⊗
Outdoor Air Hood (down-flow) (Number of Filters) (2) 16 x 25 x 1 in. (406 x 635 x 25 mm)	LAOAH10/15 53K05	⊗	⊗	⊗	⊗
Economizer Controls					
Differential Enthalpy	C1SNSR07AE 86M33	⊗	⊗	⊗	⊗
Single Enthalpy	C1SNSR06AE 86M32	⊗	⊗	⊗	⊗
Global, Enthalpy	Sensor Field Provided Factory	○	○	○	○
Differential Sensible	Furnished Factory	○	○	○	○
Barometric Relief					
Down-Flow Barometric Relief Dampers - Order Hood Separately	LAGED10/15 53K03	⊗	⊗	⊗	⊗
Hood for Down-Flow LAGED	LAGEH09/15 88K79	x	x	x	x
Horizontal Barometric Relief Dampers - Hood Furnished	LAGEDH03/15 53K04	x	x	x	x
OUTDOOR AIR					
Outdoor Air Dampers					
Damper Section (down-flow) - Motorized - Order Hood Separately	LAOADM10/15 53K53	⊗	⊗	⊗	⊗
Damper Section (down-flow) - Manual - Order Hood Separately	LAOAD10/15 66K69	⊗	⊗	⊗	⊗
Outdoor Air Hood (down-flow) (Number of Filters) (2) 16 x 25 x 1 in. (406 x 635 x 25 mm)	LAOAH10/15 53K05	⊗	⊗	⊗	⊗
Power Exhaust					
Standard Static	208/230V - LAPEF10/15 73M32	⊗	⊗	⊗	⊗
	460V - LAPEF10/15 73M33	⊗	⊗	⊗	⊗
	575V - LAPEF10/15 73M34	⊗	⊗	⊗	⊗

NOTE - The catalog and model numbers that appear here are for ordering field installed accessories only.

⊗ - Field Installed or Configure to Order (factory installed)

○ - Configure to Order (Factory Installed)

S - Configure to Order (Factory Installed) Standard Efficiency Models Only

H - Configure to Order (Factory Installed) High Efficiency Models Only

X - Field Installed.

OPTIONS / ACCESSORIES

Item	Catalog No.	090	102	120	150	
ROOF CURBS						
ClipLock 1000						
8 in. (203 mm) height	C1CURB40B-1	26W31	x	x	x	x
14 in. (356 mm) height	LARMF10/15S-14	65K34	x	x	x	x
18 in. (457 mm) height	LARMF10/15S-18	65K35	x	x	x	x
24 in. (610 mm) height	LARMF10/15S-24	35K36	x	x	x	x
Standard						
14 in. (356 mm) height	LARMF10/15-14	53K50	x	x	x	x
24 in. (610 mm) height	LARMF10/15-24	49K54	x	x	x	x
CEILING DIFFUSERS						
Step-Down Order one	RTD11-95	29G04	x			
	(Canada Only) RTD11-95S	13K61	x			
	RTD11-135	29G05		x	x	
	(Canada Only) RTD11-135S	13K62		x	x	
	RTD11-185	29G06				x
	(Canada Only) RTD11-150/180S	13K63				x
Flush Order one	FD11-95	29G08	x			
	(Canada Only) FD11-95S	13K56	x			
	FD11-135	29G09		x	x	
	(Canada Only) FD11-135S	13K57		x	x	
	FD11-185	29G10				x
	(Canada Only) FD11-150/180S	13K58				x
Transitions (Supply and Return) Order one	LASRT08/10	24L14	x			
	LASRT10/12	49K55		x	x	
	(Canada Only) LASRT10/12S	65K37		x	x	
	LASRT15	49K56				x
	LASRT15S	65K38				x

NOTE - The catalog and model numbers that appear here are for ordering field installed accessories only.

X - Field Installed.

SPECIFICATIONS

7.5 - 8.5 TON

General Data		7.5 Ton			8.5 Ton		
		LGC090S2B	LGA090H2B	LGA090H4B	LGC102S2B	LGA102H2B	LGA102H4B
Nominal Tonnage		Standard	High	High	Standard	High	High
Model No.							
Efficiency Type							
Cooling Performance	Gross Cooling Capacity - Btuh (kW)	96,000 (28.1)	93,800 (27.5)	93,000 (27.2)	106,000 (31.1)	105,000 (30.8)	103,000 (30.2)
	¹ Net Cooling Capacity - Btuh (kW)	93,000 (27.3)	90,000 (26.4)	90,000 (26.4)	102,000 (29.9)	101,000 (29.6)	99,000 (29.0)
	ARI Rated Air Flow - cfm (L/s)	3000 (1415)	2900 (1370)	2900 (1370)	3400 (1605)	3200 (1510)	3200 (1510)
	² Sound Rating Number (dB)	88	88	88	88	88	88
	Total Unit Power (kW)	9.0	8.0	8.0	9.9	9.0	8.8
	¹ EER (Btuh/Watt)	10.3	11.3	11.3	10.3	11.2	11.2
	¹ Integrated Part Load Value (Btuh/Watt)	10.8	12.0	12.3	10.4	11.7	12.2
	Refrigerant Type	R-22	R-22	R-410A	R-22	R-22	R-410A
Refrigerant Charge Furnished	Circuit 1	6 lbs. 0 oz. (2.72 kg)	10 lbs. 0 oz. (4.54 kg)	10 lbs. 8 oz. (4.76 kg)	6 lbs. 0 oz. (2.72 kg)	10 lbs. 8 oz. (4.76 kg)	10 lbs. 8 oz. (4.76 kg)
	Circuit 2	6 lbs. 0 oz. (2.72 kg)	10 lbs. 0 oz. (4.54 kg)	10 lbs. 8 oz. (4.76 kg)	6 lbs. 0 oz. (2.72 kg)	10 lbs. 8 oz. (4.76 kg)	9 lbs. 8 oz. (4.31 kg)
Refrigerant Charge Furnished with Humiditrol® Option	Circuit 1	Not Available	12 lbs. 0 oz. (5.44 kg)	10 lbs. 8 oz. (4.76 kg)	Not Available	12 lbs. 0 oz. (5.44 kg)	10 lbs. 8 oz. (4.76 kg)
	Circuit 2	Not Available	10 lbs. 0 oz. (4.54 kg)	10 lbs. 8 oz. (4.76 kg)	Not Available	10 lbs. 8 oz. (4.76 kg)	9 lbs. 8 oz. (4.31 kg)
Gas Heating Options Available - See page 13		Standard (2 Stage), Medium (2 Stage), or High (2 Stage)					
Compressor Type		Scroll (2)	Scroll (2)	Scroll (2)	Scroll (2)	Scroll (2)	Scroll (2)
Outdoor Coil	Net face area - sq. ft. (m ²)	29.3 (2.72) total			29.3 (2.72) total		
	Tube diameter - in. (mm)	3/8 (9.5)	3/8 (9.5)	3/8 (9.5)	3/8 (9.5)	3/8 (9.5)	3/8 (9.5)
	Number of rows	1	2	2	1	2	2
	Fins per inch (m)	20 (787)	20 (787)	20 (787)	20 (787)	20 (787)	20 (787)
Outdoor Coil Fans	Motor horsepower (W)	(2) 1/3 (249)			(2) 1/3 (249)		
	Motor rpm	1075			1075		
	Total Motor watts	700			700		
	Diameter - in. (mm)	(2) 24 (610)			(2) 24 (610)		
	Number of blades	3			3		
	Total air volume - cfm (L/s)	8,000 (3775)			8,000 (3775)		
Indoor Coil	Net face area - sq. ft. (m ²)	10.5 (0.98) total			10.5 (0.98) total		
	Number of rows	3			3		
	Tube diameter - in. (mm)	3/8 (9.5)			3/8 (9.5)		
	Fins per inch (m)	14 (551)			14 (551)		
	Drain connection - no. & size	(1) 1 in. NPT coupling			(1) 1 in. NPT coupling		
	Expansion device type	Balanced Port Thermostatic Expansion Valve, removeable power head					
³ Indoor Blower and Drive Selection	Nominal motor output - voltage	2 hp (1.5 kW), 3 hp (2.2 kW), 5 hp (3.7 kW)					
	Maximum usable motor output	2.3 hp (1.7 kW), 3.45 hp (2.6 kW), 5.75 hp (4.3 kW)					
	Motor - Drive kit	2 hp kit #1 - 680 - 925 rpm kit #3 - 895 - 1120 rpm		3 hp kit #1 - 680 - 925 rpm kit #2 - 680 - 925 rpm kit #3 - 895 - 1120 rpm kit #4 - 895 - 1120 rpm kit #5 - 1110 - 1395 rpm kit #6 - 1110 - 1395 rpm		5 hp kit #4 - 895 - 1120 rpm kit #6 - 1110 - 1395 rpm	
Wheel nominal diameter x width - in. (mm)		(1) 15 x 15 (381 x 381)			(1) 15 x 15 (381 x 381)		
Filters	Type of filter	Disposable, pleated MERV 7					
	Number and size - in. (mm)	(4) 18 x 24 x 2 (457 x 610 x 51)					
Electrical characteristics - 60 Hz		208/230V, 460V or 575V - 3 phase					

NOTE - Net capacity includes evaporator blower motor heat deduction. Gross capacity does not include evaporator blower motor heat deduction.
¹ Certified in accordance with the USE certification program, which is based on ARI Standard 210/240; 95°F (35°C) outdoor air temperature and 80°F (27°C) db/67°F (19°C) wb entering evaporator air; minimum external duct static pressure.
² Sound Rating Number rated in accordance with test conditions included in ARI Standard 270.
³ Using total air volume and system static pressure requirements determine from blower performance tables rpm and motor output required. Maximum usable output of motors furnished are shown. In Canada, nominal motor output is also maximum usable motor output. If motors of comparable output are used, be sure to keep within the service factor limitations outlined on the motor nameplate.

SPECIFICATIONS

10 - 12.5 TON

General Data		Nominal Tonnage		10 Ton			12.5 ton	
		Model No.	LGC120S2B	LGA120H2B	LGA120H4B	LGC150S2B	LGC150S4B	
		Efficiency Type	Standard	High	High	Standard	Standard	
Cooling Performance	Gross Cooling Capacity - Btuh (kW)		126,000 (36.6)	125,000 (36.6)	124,000 (36.4)	145,000 (42.5)	150,000 (43.9)	
	¹ Net Cooling Capacity - Btuh (kW)		120,000 (35.2)	120,000 (35.2)	120,000 (35.2)	138,000 (40.4)	140,000 (41.0)	
	ARI Rated Air Flow - cfm (L/s)		3800 (1795)	3600 (1700)	3600 (1700)	4250 (2005)	4250 (2005)	
	³ Sound Rating Number (dB)		88	88	88	88	88	
	Total Unit Power (kW)		11.6	10.9	10.9	14.5	14.4	
	¹ EER (Btuh/Watt)		10.3	11.0	11.0	9.5	9.7	
	² Integrated Part Load Value (Btuh/Watt)		10.5	11.8	12.0	9.2	10.2	
	Refrigerant Type		R-22	R-22	R-410A	R-22	R-410A	
Refrigerant Charge Furnished	Circuit 1	10 lbs. 0 oz. (4.53 kg)	11 lbs. 8 oz. (5.22 kg)	10 lbs. 8 oz. (4.77 kg)	14 lbs. 0 oz. (6.35 kg)	13 lbs. 0 oz. (5.90 kg)		
		Circuit 2	10 lbs. 0 oz. (4.53 kg)	11 lbs. 8 oz. (5.22 kg)	10 lbs. 8 oz. (4.77 kg)	14 lbs. 0 oz. (6.35 kg)	11 lbs. 8 oz. (5.22 kg)	
	Circuit 1	Not Available	13 lbs. 8 oz. (6.12 kg)	12 lbs. 8 oz. (5.68 kg)	14 lbs. 8 oz. (6.58 kg)	13 lbs. 0 oz. (5.90 kg)		
		Circuit 2	Not Available	11 lbs. 8 oz. (5.23 kg)	10 lbs. 8 oz. (4.77 kg)	14 lbs. 0 oz. (6.35 kg)	11 lbs. 8 oz. (5.22 kg)	
Gas Heating Options Available - See below			Standard (2 Stage), Medium (2 Stage), or High (2 Stage)					
Compressor Type (No.)			Scroll (2)	Scroll (2)	Scroll (2)	Scroll (2)	Scroll (2)	
Outdoor Coil	Net face area - sq. ft. (m ²)		29.3 (2.72) total			26.6 (2.47) total		
	Tube diameter - in. (mm) - No. of rows		3/8 (9.5) - 2			3/8 (9.5) - 3		
	Fins per inch (m)		20 (787)			20 (787)		
Outdoor Coil Fans	Motor horsepower (W)		(2) 1/3 (249)			(2) 1/2 (372)		
	Motor rpm		1075			1075		
	Total Motor watts		700			1150		
	Diameter - in. (mm) - no. of blades		(2) 24 (610) - 3			(2) 24 (610) - 3		
	Total air volume - cfm (L/s)		8,000 (3775)			9,000 (4245)		
Indoor Coil	Net face area - sq. ft. (m ²)		10.5 (0.98) total			10.5 (0.98) total		
	Tube diameter - in. (mm) - No. of rows		3/8 (9.5) - 4			3/8 (9.5) - 4		
	Fins per inch (m)		14 (551)			14 (551)		
	Drain connection - no. & size		(1) 1 in. NPT coupling			(1) 1 in. NPT coupling		
	Expansion device type		Balanced Port Thermostatic Expansion Valve, removeable power head					
⁴ Indoor Blower and Drive Selection	Nominal motor output		2 hp (1.5 kW), 3 hp (2.2 kW), 5 hp (3.7 kW)					
	Maximum usable motor output		2.3 hp (1.7 kW), 3.45 hp (2.6 kW), 5.75 hp (4.3 kW)					
	Motor - Drive kit		2 hp		3 hp		5 hp	
			kit #1 - 680 - 925 rpm	kit #2 - 680 - 925 rpm	kit #3 - 895 - 1120 rpm	kit #4 - 895 - 1120 rpm	kit #6 - 1110 - 1395 rpm	
Wheel nominal diameter x width - in. (mm)		(1) 15 x 15 (381 x 381)						
Filters	Type of filter		Disposable, pleated MERV 7					
	Number and size - in. (mm)		(4) 18 x 24 x 2 (457 x 610 x 51)					
Electrical characteristics			208/230V, 460V or 575V - 60 hertz - 3 phase					

NOTE - Net capacity includes evaporator blower motor heat deduction. Gross capacity does not include evaporator blower motor heat deduction.
¹ Certified in accordance with the ULE certification program, which is based on ARI Standard 340/360, 95°F (35°C) outdoor air temperature and 80°F (27°C) db/67°F (19°C) wb entering evaporator air; minimum external duct static pressure.
² Integrated Part Load Value rated at 80°F (27°C) outdoor air temperature.
³ Sound Rating Number rated in accordance with test conditions included in ARI Standard 270.
⁴ Using total air volume and system static pressure requirements determine from blower performance tables rpm and motor output required. Maximum usable output of motors furnished are shown. In Canada, nominal motor output is also maximum usable motor output. If motors of comparable output are used, be sure to keep within the service factor limitations outlined on the motor nameplate.

SPECIFICATIONS - GAS HEAT

Gas Heating Performance	Heat Input Type		Standard (2 Stage)		Medium (2 Stage)		High (2 Stage)			
			Input - Btuh (kW)	First Stage	84,500 (24.8)		117,000 (34.3)		156,000 (45.7)	
				Second Stage	130,000 (38.1)		180,000 (52.7)		240,000 (70.3)	
Output - Btuh (kW)	Second Stage	104,000 (30.5)		144,000 (42.2)		192,000 (56.3)				
Temperature Rise Range - °F			15 - 45		30 - 60		40 - 70			
CSA Thermal Efficiency			80.0%							
Gas Supply Connections			3/4 in. npt							
Recommended Gas Supply Pressure - Natural			7 in. w.c. (1.7 kPa)							
LPG/Propane			11 in. w.c. (2.7 kPa)							

HIGH ALTITUDE DERATE

Units may be installed at altitudes up to 2000 feet (610 m) above sea level without any modification. At altitudes above 2000 feet (610 m), units must be derated to match gas manifold pressures shown in table below. NOTE - This is the only permissible derate for these units.

	Altitude		Gas Manifold Pressure				Input Rate Natural Gas or LPG/Propane			
	ft.	m	Natural Gas		LPG/Propane		First Stage		Second Stage	
			in. w.g.	kPa	in. w.g.	kPa	Btuh	kW	Btuh	kW
Standard	2001 - 4500	610 - 1372	3.4	0.85	9.6	2.39	84,500	24.7	124,000	36.3
Medium	2001 - 4500	610 - 1372	3.4	0.85	9.6	2.39	117,000	34.3	172,000	50.4
High	2001 - 4500	610 - 1372	3.4	0.85	9.6	2.39	156,000	45.7	230,000	67.3

COOLING RATINGS

NOTE - For Temperatures and Capacities not shown in tables, see bulletin - Cooling Unit Rating Table Correction Factor Data in Miscellaneous Engineering Data section.

7.5 TON STANDARD EFFICIENCY (R-22) ONE COMPRESSOR OPERATING

LGC090S2

Entering Wet Bulb Temperature	Total Air Volume		Outdoor Air Temperature Entering Outdoor Coil																							
			65°F (18°C)						75°F (24°C)						85°F (29°C)						95°F (35°C)					
			Total Cooling Capacity		Comp Motor kW Input	Sensible To Total Ratio (S/T) Dry Bulb			Total Cooling Capacity		Comp Motor kW Input	Sensible To Total Ratio (S/T) Dry Bulb			Total Cooling Capacity		Comp Motor kW Input	Sensible To Total Ratio (S/T) Dry Bulb			Total Cooling Capacity		Comp Motor kW Input	Sensible To Total Ratio (S/T) Dry Bulb		
			kBtuh	kW		75°F 24°C	80°F 27°C	85°F 29°C	kBtuh	kW		75°F 24°C	80°F 27°C	85°F 29°C	kBtuh	kW		75°F 24°C	80°F 27°C	85°F 29°C	kBtuh	kW		75°F 24°C	80°F 27°C	85°F 29°C
63°F (17°C)	2400	1135	50.9	14.9	2.54	.59	.74	.90	49.3	14.4	2.83	.60	.76	.92	47.7	14.0	3.16	.61	.77	.94	46.0	13.5	3.54	.62	.79	.97
	3000	1415	52.8	15.5	2.58	.64	.83	.99	51.2	15.0	2.87	.65	.85	1.00	49.5	14.5	3.20	.66	.87	1.00	47.8	14.0	3.58	.68	.89	1.00
	3600	1700	54.4	15.9	2.61	.70	.91	1.00	52.8	15.5	2.90	.71	.93	1.00	51.0	14.9	3.23	.73	.95	1.00	49.2	14.4	3.61	.75	.97	1.00
67°F (19°C)	2400	1135	54.1	15.9	2.60	.47	.57	.70	52.4	15.4	2.89	.48	.58	.71	50.7	14.9	3.22	.48	.59	.73	48.8	14.3	3.61	.48	.59	.75
	3000	1415	55.9	16.4	2.64	.49	.61	.79	54.1	15.9	2.93	.50	.62	.81	52.2	15.3	3.26	.50	.64	.83	50.3	14.7	3.64	.51	.65	.85
	3600	1700	57.1	16.7	2.66	.52	.67	.87	55.3	16.2	2.96	.52	.69	.89	53.4	15.6	3.29	.53	.70	.92	51.4	15.1	3.67	.54	.73	.94
71°F (22°C)	2400	1135	57.5	16.9	2.67	.36	.46	.55	55.7	16.3	2.96	.36	.46	.56	53.9	15.8	3.30	.36	.46	.56	51.9	15.2	3.69	.36	.47	.57
	3000	1415	59.3	17.4	2.71	.37	.48	.59	57.4	16.8	3.00	.37	.49	.60	55.4	16.2	3.34	.37	.49	.61	53.3	15.6	3.72	.37	.50	.62
	3600	1700	60.5	17.7	2.74	.38	.51	.64	58.5	17.1	3.03	.38	.51	.66	56.5	16.6	3.36	.38	.52	.68	54.3	15.9	3.75	.38	.53	.70

7.5 TON STANDARD EFFICIENCY (R-22) ALL COMPRESSORS OPERATING

LGC090S2

Entering Wet Bulb Temperature	Total Air Volume		Outdoor Air Temperature Entering Outdoor Coil																							
			85°F (29°C)						95°F (35°C)						105°F (41°C)						115°F (46°C)					
			Total Cooling Capacity		Comp Motor kW Input	Sensible To Total Ratio (S/T) Dry Bulb			Total Cooling Capacity		Comp Motor kW Input	Sensible To Total Ratio (S/T) Dry Bulb			Total Cooling Capacity		Comp Motor kW Input	Sensible To Total Ratio (S/T) Dry Bulb			Total Cooling Capacity		Comp Motor kW Input	Sensible To Total Ratio (S/T) Dry Bulb		
			kBtuh	kW		75°F 24°C	80°F 27°C	85°F 29°C	kBtuh	kW		75°F 24°C	80°F 27°C	85°F 29°C	kBtuh	kW		75°F 24°C	80°F 27°C	85°F 29°C	kBtuh	kW		75°F 24°C	80°F 27°C	85°F 29°C
63°F (17°C)	2400	1135	91.3	26.8	6.35	.67	.81	.95	88.1	25.8	7.11	.68	.83	.97	84.6	24.8	7.99	.69	.85	.99	80.9	23.7	9.01	.70	.87	1.00
	3000	1415	94.7	27.8	6.43	.72	.89	1.00	91.4	26.8	7.19	.73	.91	1.00	87.7	25.7	8.07	.75	.94	1.00	83.9	24.6	9.09	.77	.96	1.00
	3600	1700	97.6	28.6	6.49	.78	.96	1.00	94.1	27.6	7.25	.79	.98	1.00	90.6	26.6	8.14	.81	.99	1.00	86.9	25.5	9.18	.84	1.00	1.00
67°F (19°C)	2400	1135	96.9	28.4	6.47	.53	.64	.77	93.4	27.4	7.24	.53	.66	.79	89.5	26.2	8.13	.54	.67	.81	85.7	25.1	9.15	.55	.68	.83
	3000	1415	99.9	29.3	6.55	.55	.69	.86	96.2	28.2	7.31	.56	.71	.88	92.3	27.1	8.20	.57	.72	.90	88.1	25.8	9.23	.58	.74	.93
	3600	1700	102.1	29.9	6.60	.58	.75	.93	98.2	28.8	7.36	.59	.77	.95	94.2	27.6	8.26	.60	.79	.97	89.9	26.3	9.30	.61	.82	.99
71°F (22°C)	2400	1135	103.0	30.2	6.62	.40	.51	.62	99.3	29.1	7.40	.40	.51	.63	95.3	27.9	8.29	.40	.52	.64	91.1	26.7	9.32	.40	.53	.66
	3000	1415	106.0	31.1	6.70	.41	.54	.67	102.0	29.9	7.47	.41	.55	.69	97.8	28.7	8.36	.41	.56	.70	93.3	27.3	9.40	.42	.57	.72
	3600	1700	108.0	31.7	6.75	.42	.57	.73	103.9	30.5	7.53	.42	.58	.75	99.5	29.2	8.42	.43	.59	.77	94.8	27.8	9.46	.43	.61	.79

COOLING RATINGS

NOTE - For Temperatures and Capacities not shown in tables, see bulletin - Cooling Unit Rating Table Correction Factor Data in Miscellaneous Engineering Data section.

10 TON HIGH EFFICIENCY (R-22) ONE COMPRESSOR OPERATING

LGA120H2

Table with 22 columns: Entering Wet Bulb Temperature, Total Air Volume, Total Cooling Capacity, Comp Motor kW Input, Sensible To Total Ratio (S/T) Dry Bulb (65°F, 75°F, 85°F), and Total Cooling Capacity, Comp Motor kW Input, Sensible To Total Ratio (S/T) Dry Bulb (95°F).

10 TON HIGH EFFICIENCY (R-22) ALL COMPRESSORS OPERATING

LGA120H2

Table with 22 columns: Entering Wet Bulb Temperature, Total Air Volume, Total Cooling Capacity, Comp Motor kW Input, Sensible To Total Ratio (S/T) Dry Bulb (85°F, 95°F, 105°F, 115°F).

10 TON HIGH EFFICIENCY (R-410) ONE COMPRESSOR OPERATING

LGA120H4

Table with 22 columns: Entering Wet Bulb Temperature, Total Air Volume, Total Cooling Capacity, Comp Motor kW Input, Sensible To Total Ratio (S/T) Dry Bulb (65°F, 75°F, 85°F), and Total Cooling Capacity, Comp Motor kW Input, Sensible To Total Ratio (S/T) Dry Bulb (95°F).

10 TON HIGH EFFICIENCY (R-410A) ALL COMPRESSORS OPERATING

LGA120H4

Table with 22 columns: Entering Wet Bulb Temperature, Total Air Volume, Total Cooling Capacity, Comp Motor kW Input, Sensible To Total Ratio (S/T) Dry Bulb (85°F, 95°F, 105°F, 115°F).

BLOWER DATA

BELT DRIVE BLOWER - BASE UNIT

BLOWER TABLE INCLUDES RESISTANCE FOR BASE UNIT ONLY (NO HEAT SECTION) WITH DRY INDOOR COIL AND AIR FILTERS IN PLACE. FOR ALL UNITS ADD:

- 1 - Wet indoor coil air resistance of selected unit.
- 2 - Any factory installed options air resistance (heat section, economizer, etc.)
- 3 - Any field installed accessories air resistance (duct resistance, diffuser, etc.)

Then determine from blower table blower motor output and drive required.

See below for blower motors and drives. See page 24 for wet coil and option/accessory air resistance data.

BOLD INDICATES FIELD FURNISHED DRIVE.

Air Volume cfm (L/s)	Total Static Pressure - in. w.g. (Pa)																												
	.20 (50)		.40 (100)		.60 (150)		.80 (200)		1.00 (250)		1.20 (300)		1.40 (350)		1.60 (400)		1.80 (450)		2.00 (495)		2.20 (545)		2.40 (595)		2.60 (645)				
	RPM	BHP (kW)	RPM	BHP (kW)	RPM	BHP (kW)	RPM	BHP (kW)	RPM	BHP (kW)	RPM	BHP (kW)	RPM	BHP (kW)	RPM	BHP (kW)	RPM	BHP (kW)	RPM	BHP (kW)	RPM	BHP (kW)	RPM	BHP (kW)	RPM	BHP (kW)	RPM	BHP (kW)	RPM
2250 (1060)	455	0.30 (0.22)	555	0.45 (0.34)	640	0.60 (0.45)	720	0.80 (0.60)	790	1.00 (0.75)	855	1.20 (0.90)	915	1.40 (1.04)	975	1.60 (1.19)	1030	1.85 (1.38)	1080	2.05 (1.53)	1130	2.30 (1.72)	1175	2.55 (1.90)	1220	2.80 (2.09)			
2500 (1180)	475	0.40 (0.30)	575	0.55 (0.41)	660	0.70 (0.52)	735	0.90 (0.67)	805	1.10 (0.82)	870	1.30 (0.97)	930	1.55 (1.16)	985	1.75 (1.31)	1040	2.00 (1.49)	1090	2.25 (1.68)	1140	2.50 (1.87)	1185	2.75 (2.05)	1230	3.00 (2.24)			
2750 (1300)	495	0.45 (0.34)	595	0.65 (0.48)	675	0.85 (0.63)	750	1.05 (0.78)	820	1.25 (0.93)	885	1.45 (1.08)	940	1.70 (1.27)	995	1.90 (1.42)	1050	2.20 (1.64)	1100	2.45 (1.83)	1145	2.65 (1.98)	1195	2.95 (2.20)	1240	3.25 (2.42)			
3000 (1415)	525	0.55 (0.41)	615	0.75 (0.56)	695	0.95 (0.71)	770	1.20 (0.90)	835	1.40 (1.04)	895	1.60 (1.19)	955	1.85 (1.38)	1010	2.10 (1.57)	1060	2.35 (1.75)	1110	2.65 (1.98)	1160	2.90 (2.16)	1205	3.20 (2.39)	1250	3.45 (2.57)			
3250 (1535)	550	0.65 (0.48)	640	0.90 (0.67)	715	1.10 (0.82)	790	1.35 (1.01)	855	1.60 (1.19)	915	1.80 (1.34)	970	2.05 (1.53)	1025	2.35 (1.75)	1075	2.60 (1.94)	1125	2.85 (2.13)	1170	3.15 (2.35)	1215	3.40 (2.54)	1260	3.70 (2.76)			
3500 (1650)	580	0.80 (0.60)	665	1.05 (0.78)	740	1.25 (0.93)	810	1.50 (1.12)	870	1.75 (1.31)	930	2.00 (1.49)	985	2.25 (1.68)	1040	2.55 (1.90)	1090	2.85 (2.13)	1135	3.10 (2.31)	1185	3.40 (2.54)	1230	3.70 (2.76)	1270	4.00 (2.98)			
3750 (1770)	605	0.95 (0.71)	690	1.20 (0.90)	760	1.45 (1.08)	830	1.70 (1.27)	890	1.95 (1.45)	950	2.25 (1.68)	1005	2.50 (1.87)	1055	2.80 (2.09)	1105	3.10 (2.31)	1150	3.35 (2.50)	1195	3.65 (2.72)	1240	3.95 (2.95)	1285	4.30 (3.21)			
4000 (1890)	635	1.10 (0.82)	715	1.40 (1.04)	785	1.65 (1.23)	850	1.90 (1.42)	910	2.20 (1.64)	965	2.45 (1.83)	1020	2.75 (2.05)	1070	3.05 (2.28)	1120	3.35 (2.50)	1165	3.65 (2.72)	1210	3.95 (2.95)	1255	4.30 (3.21)	1295	4.60 (3.43)			
4250 (2005)	665	1.30 (0.97)	740	1.60 (1.19)	810	1.85 (1.38)	870	2.15 (1.60)	930	2.45 (1.83)	985	2.75 (2.05)	1040	3.05 (2.28)	1090	3.35 (2.50)	1135	3.65 (2.72)	1185	4.00 (2.98)	1225	4.30 (3.21)	1270	4.65 (3.47)	1310	4.95 (3.69)			
4500 (2125)	695	1.50 (1.12)	770	1.80 (1.34)	835	2.10 (1.57)	895	2.40 (1.79)	955	2.70 (2.01)	1005	3.00 (2.24)	1060	3.35 (2.50)	1105	3.65 (2.72)	1155	4.00 (2.98)	1200	4.30 (3.21)	1245	4.65 (3.47)	1285	5.00 (3.73)	1325	5.30 (3.95)			
4750 (2240)	725	1.75 (1.31)	795	2.05 (1.53)	860	2.40 (1.79)	920	2.70 (2.01)	975	3.00 (2.24)	1030	3.35 (2.50)	1080	3.65 (2.72)	1125	3.95 (2.95)	1175	4.35 (3.25)	1215	4.65 (3.47)	1260	5.00 (3.73)	1300	5.35 (3.99)	1340	5.70 (4.25)			
5000 (2360)	760	2.05 (1.53)	825	2.35 (1.75)	885	2.65 (1.98)	945	3.00 (2.24)	1000	3.35 (2.50)	1050	3.65 (2.72)	1100	4.00 (2.98)	1145	4.35 (3.25)	1190	4.70 (3.51)	1235	5.05 (3.77)	1280	5.45 (4.07)	---	---	---	---			
5250 (2475)	790	2.30 (1.72)	855	2.65 (1.98)	910	2.95 (2.20)	970	3.35 (2.50)	1020	3.65 (2.72)	1070	4.00 (2.98)	1120	4.35 (3.25)	1165	4.70 (3.51)	1210	5.10 (3.80)	1255	5.45 (4.07)	---	---	---	---					
5500 (2595)	820	2.60 (1.94)	880	2.95 (2.20)	940	3.30 (2.46)	995	3.70 (2.76)	1045	4.05 (3.02)	1095	4.40 (3.28)	1145	4.80 (3.58)	1190	5.15 (3.84)	1230	5.50 (4.10)	---	---	---	---	---	---					
5750 (2715)	850	2.95 (2.20)	910	3.30 (2.46)	965	3.70 (2.76)	1020	4.05 (3.02)	1070	4.45 (3.32)	1120	4.80 (3.58)	1165	5.20 (3.88)	1210	5.60 (4.18)	---	---	---	---	---	---	---	---					
6000 (2830)	885	3.35 (2.50)	940	3.70 (2.76)	995	4.10 (3.06)	1045	4.45 (3.32)	1095	4.85 (3.62)	1145	5.25 (3.92)	1190	5.65 (4.21)	---	---	---	---	---	---	---	---	---	---					

FACTORY INSTALLED BELT DRIVE KIT SPECIFICATIONS

Motor Efficiency	Motor Outputs				RPM Range					
	Nominal hp	kW	Maximum hp	kW	Drive 1	Drive 2	Drive 3	Drive 4	Drive 5	Drive 6
Standard or High	2	1.5	2.3	1.7	680 - 925	---	895 - 1120	---	---	---
Standard	3	2.2	3.45	2.6	680 - 925	---	895 - 1120	---	1110 - 1395	---
High	3	2.2	3.45	2.6	---	680 - 925	---	895 - 1120	---	1110 - 1395
Standard or High	5	3.7	5.75	4.3	---	---	---	895 - 1120	---	1110 - 1395

NOTE - Using total air volume and system static pressure requirements determine from blower performance tables rpm and motor output required. Maximum usable output of motors furnished by Lennox are shown. In Canada, nominal motor output is also maximum usable motor output. If motors of comparable output are used, be sure to keep within the service factor limitations outlined on the motor nameplate.

BLOWER DATA

FACTORY INSTALLED OPTIONS/FIELD INSTALLED ACCESSORY AIR RESISTANCE

Air Volume		Wet Indoor Coil				Humiditrol Condenser Reheat Coil		Gas Heat Exchanger						Economizer		Filters	
		090, 102		120,150				Standard Heat		Medium Heat		High Heat				MERV 11	
cfm	L/s	in. w.g.	Pa	in. w.g.	Pa	in. w.g.	Pa	in. w.g.	Pa	in. w.g.	Pa	in. w.g.	Pa	in. w.g.	Pa	in. w.g.	Pa
2250	1060	0.06	15	0.10	25	0.02	5	0.05	12	0.07	17	0.09	22	0.035	9	0.01	2
2500	1180	0.08	20	0.12	30	0.03	7	0.05	12	0.09	22	0.11	27	0.04	10	0.01	2
2750	1325	0.09	22	0.14	35	0.03	7	0.06	15	0.10	25	0.13	32	0.045	11	0.02	5
3000	1420	0.10	25	0.16	40	0.03	7	0.07	17	0.12	30	0.16	40	0.05	12	0.02	5
3250	1535	0.11	27	0.19	47	0.04	10	0.08	20	0.15	37	0.19	47	0.06	15	0.02	5
3500	1650	0.13	32	0.21	52	0.04	10	0.09	22	0.17	42	0.22	55	0.07	17	0.03	7
3750	1770	0.14	35	0.23	57	0.05	12	0.10	25	0.20	50	0.26	65	0.075	19	0.03	7
4000	1890	0.16	40	0.26	65	0.05	12	0.11	27	0.22	55	0.30	75	0.08	20	0.04	10
4250	2005	0.17	42	0.28	70	0.06	15	0.12	30	0.25	62	0.34	85	0.09	22	0.04	10
4500	2125	0.18	45	0.31	77	0.07	17	0.13	32	0.28	70	0.38	94	0.10	25	0.04	10
4750	2240	0.20	50	0.33	82	0.07	17	0.14	35	0.31	77	0.42	104	0.11	27	0.05	12
5000	2360	0.22	55	0.36	90	0.08	20	0.16	40	0.35	87	0.47	117	0.12	30	0.06	15
5250	2475	0.24	60	0.39	97	0.08	20	0.18	45	0.38	94	0.52	129	0.13	32	0.06	15
5500	2595	0.26	65	0.42	104	0.09	22	0.20	50	0.42	104	0.57	142	0.14	35	0.07	17
5750	2715	0.28	70	0.45	112	0.10	25	0.22	55	0.46	114	0.62	154	0.15	37	0.07	17
6000	2830	0.30	75	0.48	119	0.10	25	0.24	60	0.50	124	0.68	169	0.16	40	0.08	20

AIR RESISTANCE - CEILING DIFFUSERS

Unit Size	Air Volume		RTD11 Step-Down Diffuser						FD11 Flush Diffuser	
			2 Ends Open		1 Side, 2 Ends Open		All Ends & Sides Open			
	cfm	L/s	in. w.g.	Pa	in. w.g.	Pa	in. w.g.	Pa	in. w.g.	Pa
090 Models	2400	1135	0.21	52	0.18	45	0.15	37	0.14	35
	2600	1225	0.24	60	0.21	52	0.18	45	0.17	42
	2800	1320	0.27	67	0.24	60	0.21	52	0.20	50
	3000	1415	0.32	80	0.29	72	0.25	62	0.25	62
	3200	1510	0.41	102	0.37	92	0.32	80	0.31	77
	3400	1605	0.50	124	0.45	112	0.39	97	0.37	92
	3600	1700	0.61	152	0.54	134	0.48	119	0.44	109
3800	1795	0.73	182	0.63	157	0.57	142	0.51	127	
102 & 120 Models	3600	1700	0.36	90	0.28	70	0.23	57	0.15	37
	3800	1795	0.40	99	0.32	80	0.26	65	0.18	45
	4000	1890	0.44	109	0.36	90	0.29	72	0.21	52
	4200	1980	0.49	122	0.40	99	0.33	82	0.24	60
	4400	2075	0.54	134	0.44	109	0.37	92	0.27	67
	4600	2170	0.60	149	0.49	122	0.42	104	0.31	77
	4800	2265	0.65	162	0.53	132	0.46	114	0.35	87
5000	2360	0.69	172	0.58	144	0.50	124	0.39	97	
5200	2455	0.75	186	0.62	154	0.54	134	0.43	107	
150 Models	4200	1980	0.22	55	0.19	47	0.16	40	0.10	25
	4400	2075	0.28	70	0.24	60	0.20	50	0.12	30
	4600	2170	0.34	85	0.29	72	0.24	60	0.15	37
	4800	2265	0.40	99	0.34	85	0.29	72	0.19	47
	5000	2360	0.46	114	0.39	97	0.34	85	0.23	57
	5200	2455	0.52	129	0.44	109	0.39	97	0.27	67
	5400	2550	0.58	144	0.49	122	0.43	107	0.31	77
5600	2645	0.64	159	0.54	134	0.47	117	0.35	87	
5800	2735	0.70	174	0.59	147	0.51	127	0.39	97	

BLOWER DATA

CEILING DIFFUSER AIR THROW DATA

Model No.	Air Volume		¹ Effective Throw Range			
	cfm	L/s	RTD11 Step-Down		FD11 Flush	
			ft.	m	ft.	m
090	2600	1225	24 - 29	7 - 9	19 - 24	6 - 7
	2800	1320	25 - 30	8 - 9	20 - 28	6 - 9
	3000	1415	27 - 33	8 - 10	21 - 29	6 - 9
	3200	1510	28 - 35	9 - 11	22 - 29	7 - 9
	3400	1605	30 - 37	9 - 11	22 - 30	7 - 9
102 120	3600	1700	25 - 33	8 - 10	22 - 29	7 - 9
	3800	1795	27 - 35	8 - 11	22 - 30	7 - 9
	4000	1885	29 - 37	9 - 11	24 - 33	7 - 10
	4200	1980	32 - 40	10 - 12	26 - 35	8 - 11
	4400	2075	34 - 42	10 - 13	28 - 37	9 - 11
150	5600	2645	39 - 49	12 - 15	28 - 37	9 - 11
	5800	2740	42 - 51	13 - 16	29 - 38	9 - 12
	6000	2830	44 - 54	13 - 17	40 - 50	12 - 15
	6200	2925	45 - 55	14 - 17	42 - 51	13 - 16
	6400	3020	46 - 55	14 - 17	43 - 52	13 - 16
	6600	3115	47 - 56	14 - 17	45 - 56	14 - 17

¹ Throw is the horizontal or vertical distance an air stream travels on leaving the outlet or diffuser before the maximum velocity is reduced to 50 ft. (15 m) per minute. Four sides open.

POWER EXHAUST FANS PERFORMANCE

Return Air System Static Pressure		Air Volume Exhausted	
in. w.g.	Pa	cfm	L/s
0	0	4200	1980
0.05	12	3970	1875
0.10	25	3750	1770
0.15	37	3520	1660
0.20	50	3300	1560
0.25	62	3080	1455
0.30	75	2860	1350
0.35	87	2640	1245

ELECTRICAL DATA

7.5 TON

7.5 TON STANDARD EFFICIENCY (R-22)

LGC090S2

¹ Voltage - 60hz - 3 phase		208/230V			460V			575V		
Compressors (2)	Rated Load Amps (Total)	12.8 (25.6)			6.4 (12.8)			5.1 (10.2)		
	Locked Rotor Amps (Total)	91 (182)			46 (92)			37 (74)		
Outdoor Fan Motors (2) - Full Load Amps (total)		2.4 (4.8)			1.3 (2.6)			1 (2)		
Power Exhaust (1) 0.33 HP - Full Load Amps		2.4			1.3			1		
Service Outlet 115V GFI (Amps)		15			15			15		
Indoor Blower Motor	Horsepower	2	3	5	2	3	5	2	3	5
	Full Load Amps	7.5	10.6	16.7	3.4	4.8	7.6	2.7	3.9	6.1
² Maximum Overcurrent Protection	Unit Only	50	50	60	25	25	30	20	20	25
	With (1) 0.33 HP Power Exhaust	50	50	70	25	25	30	20	20	25
³ Minimum Circuit Ampacity	Unit Only	42	45	51	21	22	25	17	18	20
	With (1) 0.33 HP Power Exhaust	44	47	53	22	24	26	18	19	21

ELECTRIC ACCESSORIES

Disconnect	84M13	84M13	84M13	84M13	84M13
------------	--------------	--------------	--------------	--------------	--------------

7.5 TON HIGH EFFICIENCY (R-22)

LGA090H2

¹ Voltage - 60hz - 3 phase		208/230V			460V			575V		
Compressors (2)	Rated Load Amps (Total)	12.4 (24.8)			6.4 (12.8)			4.8 (9.6)		
	Locked Rotor Amps (Total)	88 (176)			44 (88)			34 (68)		
Outdoor Fan Motors (2) - Full Load Amps (total)		2.4 (4.8)			1.3 (2.6)			1 (2)		
Power Exhaust (1) 0.33 HP - Full Load Amps		2.4			1.3			1		
Service Outlet 115V GFI (Amps)		15			15			15		
Indoor Blower Motor	Horsepower	2	3	5	2	3	5	2	3	5
	Full Load Amps	7.5	10.6	16.7	3.4	4.8	7.6	2.7	3.9	6.1
² Maximum Overcurrent Protection	Unit Only	50	50	60	25	25	30	20	20	25
	With (1) 0.33 HP Power Exhaust	50	50	60	25	25	30	20	20	25
³ Minimum Circuit Ampacity	Unit Only	41	44	50	21	22	25	16	17	19
	With (1) 0.33 HP Power Exhaust	43	46	52	22	24	26	17	18	20

ELECTRIC ACCESSORIES

Disconnect	84M13	84M13	84M13	84M13	84M13
------------	--------------	--------------	--------------	--------------	--------------

7.5 TON HIGH EFFICIENCY (R-410)

LGA090H4

¹ Voltage - 60hz - 3 phase		208/230V			460V			575V		
Compressors (2)	Rated Load Amps (Total)	14.6 (29.2)			7.1 (14.2)			5.1 (10.2)		
	Locked Rotor Amps (Total)	91 (182)			46 (92)			34 (68)		
Outdoor Fan Motors (2) - Full Load Amps (total)		2.4 (4.8)			1.3 (2.6)			1 (2)		
Power Exhaust (1) 0.33 HP - Full Load Amps		2.4			1.3			1		
Service Outlet 115V GFI (Amps)		15			15			15		
Indoor Blower Motor	Horsepower	2	3	5	2	3	5	2	3	5
	Full Load Amps	7.5	10.6	16.7	3.4	4.8	7.6	2.7	3.9	6.1
² Maximum Overcurrent Protection	Unit Only	50	60	70	25	30	30	20	20	25
	With (1) 0.33 HP Power Exhaust	60	60	70	30	30	35	20	20	25
³ Minimum Circuit Ampacity	Unit Only	46	49	55	22	24	27	17	18	20
	With (1) 0.33 HP Power Exhaust	48	51	57	24	25	28	18	19	21

ELECTRIC ACCESSORIES

Disconnect	84M13	84M13	84M13	84M13	84M13
------------	--------------	--------------	--------------	--------------	--------------

¹ Extremes of operating range are plus and minus 10% of line voltage.

² HACR type breaker or fuse.

³ Refer to National or Canadian Electrical Code manual to determine wire, fuse and disconnect size requirements.

ELECTRICAL DATA**8.5 TON****8.5 TON STANDARD EFFICIENCY (R-22)****LGC102S2**

¹ Voltage - 60hz - 3 phase		208/230V			460V			575V		
Compressors (2)	Rated Load Amps (Total)	14.7 (29.4)			7.1 (14.2)			5.8 (11.6)		
	Locked Rotor Amps (Total)	91 (182)			50 (100)			37 (74)		
Outdoor Fan Motors (2) - Full Load Amps (total)		2.4 (4.8)			1.3 (2.6)			1 (2)		
Power Exhaust (1) 0.33 HP - Full Load Amps		2.4			1.3			1		
Service Outlet 115V GFI (Amps)		15			15			15		
Indoor Blower Motor	Horsepower	2	3	5	2	3	5	2	3	5
	Full Load Amps	7.5	10.6	16.7	3.4	4.8	7.6	2.7	3.9	6.1
² Maximum Overcurrent Protection	Unit Only	60	60	70	25	30	30	20	20	25
	With (1) 0.33 HP Power Exhaust	60	60	70	30	30	35	20	25	25
³ Minimum Circuit Ampacity	Unit Only	46	49	55	22	24	27	18	19	22
	With (1) 0.33 HP Power Exhaust	48	51	57	24	25	28	19	20	23

ELECTRIC ACCESSORIES

Disconnect	0-15 kW	84M13	84M13	84M13	84M13	84M13
------------	---------	-------	-------	-------	-------	-------

8.5 TON HIGH EFFICIENCY (R-22)**LGA102H2**

¹ Voltage - 60hz - 3 phase		208/230V			460V			575V		
Compressors (2)	Rated Load Amps (Total)	14.7 (29.4)			7.1 (14.2)			5.1 (10.2)		
	Locked Rotor Amps (Total)	91 (182)			50 (100)			37 (74)		
Outdoor Fan Motors (2) - Full Load Amps (total)		2.4 (4.8)			1.3 (2.6)			1 (2)		
Power Exhaust (1) 0.33 HP - Full Load Amps		2.4			1.3			1		
Service Outlet 115V GFI (Amps)		15			15			15		
Indoor Blower Motor	Horsepower	2	3	5	2	3	5	2	3	5
	Full Load Amps	7.5	10.6	16.7	3.4	4.8	7.6	2.7	3.9	6.1
² Maximum Overcurrent Protection	Unit Only	60	60	70	25	30	30	20	20	25
	With (1) 0.33 HP Power Exhaust	60	60	70	30	30	35	20	20	25
³ Minimum Circuit Ampacity	Unit Only	46	49	55	22	24	27	17	18	20
	With (1) 0.33 HP Power Exhaust	48	51	57	24	25	28	18	19	21

ELECTRIC ACCESSORIES

Disconnect		84M13	84M13	84M13	84M13	84M13
------------	--	-------	-------	-------	-------	-------

8.5 TON HIGH EFFICIENCY (R-410A)**LGA102H4**

¹ Voltage - 60hz - 3 phase		208/230V			460V			575V		
Compressors (2)	Rated Load Amps (Total)	17.9 (35.8)			7.9 (15.8)			6.2 (12.4)		
	Locked Rotor Amps (Total)	91 (182)			46 (92)			37 (74)		
Outdoor Fan Motors (2) - Full Load Amps (total)		2.4 (4.8)			1.3 (2.6)			1 (2)		
Power Exhaust (1) 0.33 HP - Full Load Amps		2.4			1.3			1		
Service Outlet 115V GFI (Amps)		15			15			15		
Indoor Blower Motor	Horsepower	2	3	5	2	3	5	2	3	5
	Full Load Amps	7.5	10.6	16.7	3.4	4.8	7.6	2.7	3.9	6.1
² Maximum Overcurrent Protection	Unit Only	70	70	70	30	30	35	20	25	25
	With (1) 0.33 HP Power Exhaust	70	70	80	30	30	35	25	25	25
³ Minimum Circuit Ampacity	Unit Only	53	56	62	24	26	28	19	20	23
	With (1) 0.33 HP Power Exhaust	55	59	65	26	27	30	20	21	24

ELECTRIC ACCESSORIES

Disconnect		84M13	84M13	84M13	84M13	84M13
------------	--	-------	-------	-------	-------	-------

¹ Extremes of operating range are plus and minus 10% of line voltage.² HACR type breaker or fuse.³ Refer to National or Canadian Electrical Code manual to determine wire, fuse and disconnect size requirements.

ELECTRICAL DATA**10 TON****10 TON STANDARD EFFICIENCY (R-22)****LGC120S2**

¹ Voltage - 60hz - 3 phase		208/230V			460V			575V		
Compressors (2)	Rated Load Amps (Total)	15.4 (30.8)			7.4 (14.8)			5.9 (11.8)		
	Locked Rotor Amps (Total)	124 (248)			59.6 (119.2)			49.4 (98.8)		
Outdoor Fan Motors (2) - Full Load Amps (total)		2.4 (4.8)			1.3 (2.6)			1 (2)		
Power Exhaust (1) 0.33 HP - Full Load Amps		2.4			1.3			1		
Service Outlet 115V GFI (Amps)		15			15			15		
Indoor Blower Motor	Horsepower	2	3	5	2	3	5	2	3	5
	Full Load Amps	7.5	10.6	16.7	3.4	4.8	7.6	2.7	3.9	6.1
² Maximum Overcurrent Protection	Unit Only	60	60	70	30	30	30	20	25	25
	With (1) 0.33 HP Power Exhaust	60	60	70	30	30	35	20	25	25
³ Minimum Circuit Ampacity	Unit Only	47	51	57	23	25	27	18	20	22
	With (1) 0.33 HP Power Exhaust	50	53	59	24	26	29	19	21	23

ELECTRIC ACCESSORIES

Disconnect	84M13	84M13	84M13	84M13	84M13
-------------------	--------------	--------------	--------------	--------------	--------------

10 TON HIGH EFFICIENCY (R-22)**LGA120H2**

¹ Voltage - 60hz - 3 phase		208/230V			460V			575V		
Compressors (2)	Rated Load Amps (Total)	17.3 (34.6)			9 (18)			7.1 (14.2)		
	Locked Rotor Amps (Total)	123 (246)			62 (124)			50 (110)		
Outdoor Fan Motors (2) - Full Load Amps (total)		2.4 (4.8)			1.3 (2.6)			1 (2)		
Power Exhaust (1) 0.33 HP - Full Load Amps		2.4			1.3			1		
Service Outlet 115V GFI (Amps)		15			15			15		
Indoor Blower Motor	Horsepower	2	3	5	2	3	5	2	3	5
	Full Load Amps	7.5	10.6	16.7	3.4	4.8	7.6	2.7	3.9	6.1
² Maximum Overcurrent Protection	Unit Only	60	70	70	35	35	35	25	25	30
	With (1) 0.33 HP Power Exhaust	70	70	80	35	35	40	25	25	30
³ Minimum Circuit Ampacity	Unit Only	52	55	61	27	28	31	21	22	25
	With (1) 0.33 HP Power Exhaust	54	57	63	28	29	32	22	23	26

ELECTRIC ACCESSORIES

Disconnect	84M13	84M13	84M13	84M13	84M13
-------------------	--------------	--------------	--------------	--------------	--------------

10 TON HIGH EFFICIENCY (R-410)**LGA120H4**

¹ Voltage - 60hz - 3 phase		208/230V			460V			575V		
Compressors (2)	Rated Load Amps (Total)	15.6 (31.2)			7.8 (15.6)			5.8 (11.6)		
	Locked Rotor Amps (Total)	110 (220)			52 (104)			38.9 (77.8)		
Outdoor Fan Motors (2) - Full Load Amps (total)		2.4 (4.8)			1.3 (2.6)			1 (2)		
Power Exhaust (1) 0.33 HP - Full Load Amps		2.4			1.3			1		
Service Outlet 115V GFI (Amps)		15			15			15		
Indoor Blower Motor	Horsepower	2	3	5	2	3	5	2	3	5
	Full Load Amps	7.5	10.6	16.7	3.4	4.8	7.6	2.7	3.9	6.1
² Maximum Overcurrent Protection	Unit Only	60	60	70	30	30	35	20	20	25
	With (1) 0.33 HP Power Exhaust	60	60	70	30	30	35	20	25	25
³ Minimum Circuit Ampacity	Unit Only	48	51	57	24	25	28	18	19	22
	With (1) 0.33 HP Power Exhaust	50	53	59	25	27	30	19	20	23

ELECTRIC ACCESSORIES

Disconnect	84M13	84M13	84M13	84M13	84M13
-------------------	--------------	--------------	--------------	--------------	--------------

¹ Extremes of operating range are plus and minus 10% of line voltage.² HACR type breaker or fuse.³ Refer to National or Canadian Electrical Code manual to determine wire, fuse and disconnect size requirements.

ELECTRICAL DATA**12.5 TON****12.5 TON STANDARD EFFICIENCY (R-22)****LGC150S2**

¹ Voltage - 60hz - 3 phase		208/230V			460V			575V		
Compressors (2)	Rated Load Amps (Total)	18.6 (37.2)			9 (18)			7.4 (14.8)		
	Locked Rotor Amps (Total)	156 (312)			75 (150)			54 (108)		
Outdoor Fan Motors (2) - Full Load Amps (total)		3 (6)			1.5 (3)			1.2 (2.4)		
Power Exhaust (1) 0.33 HP - Full Load Amps		2.4			1.3			1		
Service Outlet 115V GFI (Amps)		15			15			15		
Indoor Blower Motor	Horsepower	2	3	5	2	3	5	2	3	5
	Full Load Amps	7.5	10.6	16.7	3.4	4.8	7.6	2.7	3.9	6.1
² Maximum Overcurrent Protection	Unit Only	70	70	80	35	35	35	25	30	30
	With (1) 0.33 HP Power Exhaust	70	70	80	35	35	40	30	30	30
³ Minimum Circuit Ampacity	Unit Only	56	59	65	27	29	31	22	23	26
	With (1) 0.33 HP Power Exhaust	58	61	67	28	30	33	23	24	27

ELECTRIC ACCESSORIES

Disconnect	84M13	84M13	84M13	84M13	84M13
-------------------	--------------	--------------	--------------	--------------	--------------

12.5 TON STANDARD EFFICIENCY (R-410A)**LGC150S4**

¹ Voltage - 60hz - 3 phase		208/230V			460V			575V		
Compressors (2)	Rated Load Amps (Total)	22.4 (44.8)			10.6 (21.2)			7.7 (15.4)		
	Locked Rotor Amps (Total)	149 (298)			75 (150)			54 (108)		
Outdoor Fan Motors (2) - Full Load Amps (total)		3 (6)			1.5 (3)			1.2 (2.4)		
Power Exhaust (1) 0.33 HP - Full Load Amps		2.4			1.3			1		
Service Outlet 115V GFI (Amps)		15			15			15		
Indoor Blower Motor	Horsepower	2	3	5	2	3	5	2	3	5
	Full Load Amps	7.5	10.6	16.7	3.4	4.8	7.6	2.7	3.9	6.1
² Maximum Overcurrent Protection	Unit Only	80	80	90	40	40	45	30	30	30
	With (1) 0.33 HP Power Exhaust	80	90	90	40	40	45	30	30	30
³ Minimum Circuit Ampacity	Unit Only	64	67	74	31	32	35	23	24	26
	With (1) 0.33 HP Power Exhaust	67	70	76	32	33	36	24	25	27

ELECTRIC ACCESSORIES

Disconnect	Unit Only	84M13	84M13	84M14	84M13	84M13
	With (1) 0.33 HP Power Exhaust	84M13	84M14	84M14	84M13	84M13

¹ Extremes of operating range are plus and minus 10% of line voltage.² HACR type breaker or fuse.³ Refer to National or Canadian Electrical Code manual to determine wire, fuse and disconnect size requirements.

OUTDOOR SOUND DATA

Unit Model No.	Octave Band Sound Power Levels dBA, re 10 ⁻¹² Watts							¹ Sound Rating Number (dB)
	Center Frequency - HZ							
	125	250	500	1000	2000	4000	8000	
090, 102, and 120	76	79	84	83	79	73	66	88
150	77	80	85	84	79	74	66	88

NOTE - The octave sound power data shown does not include tonal correction.

¹ Sound Rating Number according to ARI Standard 270-95.

UNIT CLEARANCES - INCHES (MM)

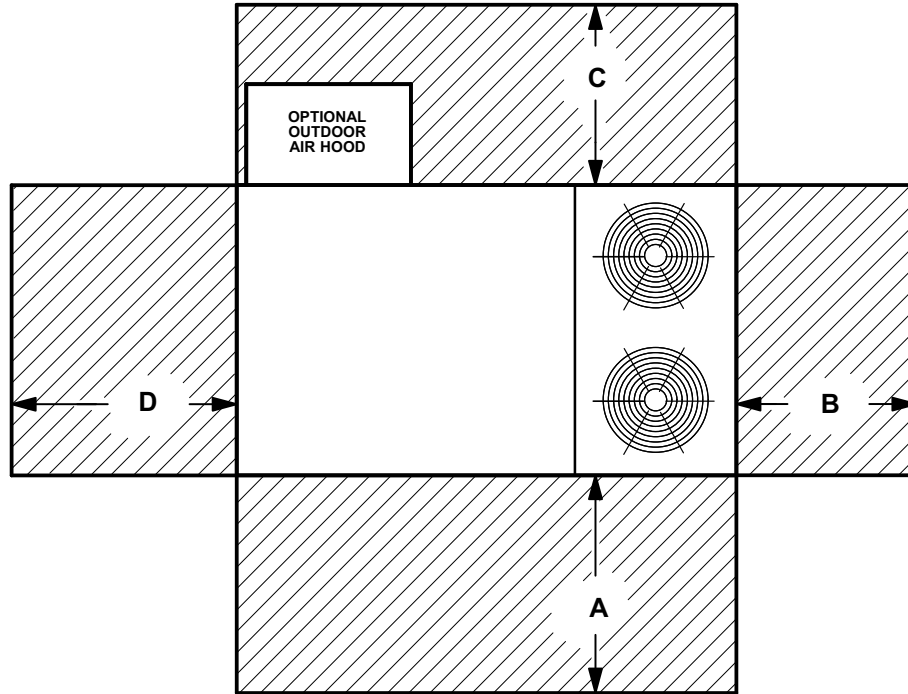

¹ Unit Clearance	A		B		C		D		Top Clearance
	in.	mm	in.	mm	in.	mm	in.	mm	
Service Clearance	60	1524	36	914	36	914	66	1676	Unobstructed
Clearance to Combustibles	36	914	1	25	1	25	1	25	
Minimum Operation Clearance	36	914	36	914	36	914	36	914	

NOTE - Entire perimeter of unit base requires support when elevated above the mounting surface.

¹ Service Clearance - Required for removal of serviceable parts.

Clearance to Combustibles - Required clearance to combustible material.

Minimum Operation Clearance - Required clearance for proper unit operation.

OPTIONAL UNIT CONTROLLERS AND SYSTEMS INTEGRATION

FACTORY OR FIELD INSTALLED

NOVAR ETM-2051

Electronic Thermostat Module (ETM)/Blower Proving Switch/Return Air Sensor/Discharge Air Sensor/Wiring Harness -

Module monitors unit operation from different sensors installed in unit and monitors unit diagnostic codes of the IMC. The ETM has outputs for 2 stage heat/2 stage cool, 7 relay outputs: fan Cool 1, Cool 2, Heat 1, Heat 2, Economizer, Night Mode, automatic or continuous blower operation, economizer damper operation and night setback, features: day/occupied mode with low enthalpy (outdoor air damper open), high enthalpy (outdoor air damper closed) or night/unoccupied mode (outdoor air damper closed), network communication (RS-485, shielded pair twisted wire), local override (1 to 255 minutes), watchdog function, fail-safe operation, ETM allows units to be "daisy chained" together (up to 31 units) to be operated from one central location with an "executive" type control processor (on-site or off-site), built-in time delays, built-in unit operating defaults, diagnostic LED's indicate various operating functions, surge suppression protects ETM against lightning or voltage spikes, Blower Proving Switch monitors blower operation and locks out unit in case of blower failure, Return Air Sensor provides input to ETM module to determine heating or cooling operation and number of stages required, Discharge Air Sensor monitors leaving air temperature during unit operation.

C0CTRL35EA1L

FIELD INSTALLED

Room Temperature Sensor with Adjustable Temperature Setpoint and Built-in Night Setback Override Button - Provides input to ETM module to determine heating or cooling operation and number of stages required. Temperature setpoint adjustment. Override button allows momentary override of night setback during unoccupied mode. Status LED.

C0SNZN75AE1-

Room Temperature Sensor - Provides input to ETM module to determine heating or cooling operation and number of stages required.

C0SNZN74AE1-

Room Temperature Sensor with Switchover - Used to sense indoor space temperatures in commercial and industrial environments. In programmable "fall-back" configuration, provides capability to switch over control to a secondary sensor if the signal is lost from this sensor.

C0SNZN76AE1-

Averaging Sensor - Used for temperature averaging in a large room.

C0SNZN74AE1-

Override Switch - After Hours Remote Override Button - Wall Plate furnished.

C0SWCH20AE1-

Dirty Filter Switch - Senses static pressure increase indicating a dirty filter condition.

C0SWCH00AE1-

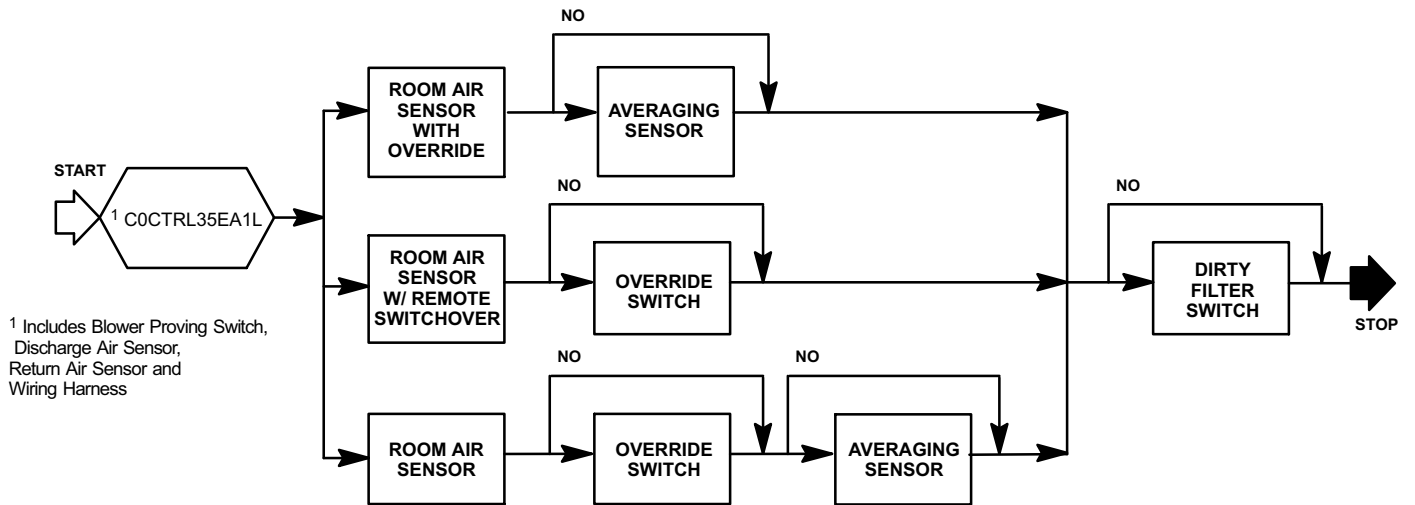

OPTIONAL UNIT CONTROLLERS AND SYSTEMS INTEGRATION

FACTORY OR FIELD INSTALLED

IMC LONTALK® MODULE

The IMC LonTalk module allows communication between the Lennox IMC (M1-7, v5.10+) controller and a LonWorks® network. The module translates input and output variables between the Lennox protocol and the LonTalk protocol. The IMC LonTalk Module has been developed to communicate with building automation systems that support the LonMark® Space Comfort Controller (SCC) or Discharge Air Controller (DAC) functional profiles. A Lennox zone sensor, a LonTalk network zone sensor, or a LonTalk thermostat or DDC controller may be used to send the zone temperature or thermostat demands to the IMC.

The IMC LonTalk Module utilizes an FTT-10A free topology transceiver communicating at 78.8 kbps. It is compatible with Echelon® qualified twisted pair cable such as Lennox model no. C0MISC03AE1-, Belden 8471 or NEMA Level 4 cables. The Module can communicate up to 1640 ft. (500m) with no repeater and up to 3200 ft. (1000m) with one repeater. The LonWorks limit of 64 nodes per segment applies to this device. One termination module, Lennox model no. C0MISC90AE1- is required for free topology segments and two are required for doubly terminated bus topology segments. Termination modules must be field provided.

C0CTRL51AE1L

NOTE: A qualified systems integrator with adequate training and experience is required to integrate and commission the IMC LonTalk Module into a third-party LonTalk building automation system. A LonWorks network configuration software tool such as LonMaker® (or equivalent) is required to commission the LonWorks network. An external interface file (XIF) will be made available upon request.

LONWORKS NETWORK VARIABLES - INPUTS

LonMark Name	Variable Type	Description
nviApplicMode	SNVT_hvac_mode	Unit application mode
0-Auto		Auto (unit-defined operation)
1-Heat		Demand for full heating
3-Cool		Demand for full cooling
6-Off		Unit off (IMC standby)
9-Fan only		Main fan (blower) on
254-Reset		Force controller reset
255-Null		Same as auto.
nviOAMinPos		SNVT_lev_percent
nviOccManCmd	SNVT_occupancy	Zone occupied status
nviOccSchedule	SNVT_tod_event	Occupancy scheduler input used to put controller unit into different occupancy modes
nviOccSensor	SNVT_occupancy	Occupancy sensor input. Used to indicate the presence of occupants
nviSpaceDehumSP	SNVT_lev_percent	Zone relative humidity set point
nviSetpoint	SNVT_temp_p	Zone temperature setpoint
nviSetptOffset	SNVT_temp_p	Zone temp setpoint offset
nviSpaceTemp	SNVT_temp_p	Remote zone temp.
nviEmergOverride	SNVT_hvac_emerg	Emergency smoke override
nviComprEnable	SNVT_switch	Compressor enable
nviPriHeatEnable	SNVT_switch	Primary heat enable
nviAuxHeatEnable	SNVT_switch	Auxiliary heat enable

OPTIONAL UNIT CONTROLLERS AND SYSTEMS INTEGRATION

IMC LONTALK® MODULE (Continued)

LONWORKS NETWORK VARIABLES - OUTPUTS

LonMark Name	Variable Type	Description
snvoIMCVersion	Manufacturer defined	IMC firmware version. D0-D3 (ASCII)
snvoUnitID	Manufacturer defined	Unit ID. \$3x-Gas/Elect \$4x-Elect/Elect \$5x-Heat Pump
nvoUnitStatus:	SNVT_hvac_status	Unit operation mode (i.e. cool, heat, etc)
1 - HVAC heat		
2 - HVAC morning warmup		
3 - HVAC cool		
5 - HVAC pre-cool		
6 - HVAC off		
7 - HVAC test		
8 - HVAC emergency heat		
9 - HVAC fan only		
12 - HVAC max heat		
14 - HVAC dehumidification		
129 - HVAC fresh air heating		
131 - HVAC fresh air cooling		
145 - HVAC defrost 1		
161 - HVAC defrost 2		
177 - HVAC defrost 1 2		
nvoSpaceTemp	SNVT_temp_p	Zone Temperature, effective
nvoDischAirTemp	SNVT_temp_p	Supply air temperature
nvoEffectOccup	SNVT_occupancy	Zone occupied status
nvoLocalOATemp	SNVT_temp_p	Outdoor air temperature
nvoLocalSpaceTemp	SNVT_temp_p	Zone Temperature, local
nvoOADamper	SNVT_lev_percent	Economizer damper position
nvoHeatPrimary	SNVT_lev_percent	Primary heating status
nvoHeatSecondary	SNVT_lev_percent	Heat pump electric strip heating status
nvoCoolPrimary	SNVT_lev_percent	Cooling compressor 1-4 status (on/off)
nvoEconEnabled	SNVT_switch	Economizer outdoor air suitable
nvoSupFanStatus	SNVT_switch	Supply fan status
nvoEffectSetpt	SNVT_temp_p	Zone temperature set points
snvoCurrentError	Manufacturer defined	Currently displayed error code
snvoCommStatus	Manufacturer defined	IMC Communicating
snvoErrorPointer	Manufacturer defined	Error pointer. This value points to the next available alarm code location. It runs from 0 to 83 and then returns to 0. Tracking this value and using the ten most recent IMC error codes (next variable) allows an application to 1) determine when new errors are logged by the IMC, 2) what those errors are, and 3) if any errors have been missed due to network delays or other reasons.
snvoMostRecErr1-10	Manufacturer defined	Alarm codes listed in the IMC manual
nvoSpaceCO2	SNVT_ppm	Zone CO ₂ level (PPM), local
nvoSpaceRHEff	SNVT_lev_percent	Zone relative humidity, effective
nvoSpaceRH	SNVT_lev_percent	Zone relative humidity, local
nvoEffSpaceDHSP	SNVT_lev_percent	Zone relative humidity set point
nvoDehumidifier	SNVT_switch	Dehumidification status
nvoRATemp	SNVT_temp_p	Return air temperature
nvoBldgStatPress	SNVT_press_p	Analog Input 2 (GP1 - VAV Bldg Static)
nvoDuctStatPress	SNVT_press_p	Analog Input 1 (GP1 - VAV Supply Static)
nvoExhFanStatus	SNVT_switch	Exhaust fan status

OPTIONAL UNIT CONTROLLERS AND SYSTEMS INTEGRATION

FACTORY OR FIELD INSTALLED

IMC BACNET® MODULE

The IMC BACnet module allows communication between the Lennox IMC (M1-7, v5.10+) controller and a BACnet MSTP network. The module translates input and output variables between the Lennox protocol and the BACnet protocol. The IMC BACnet Module has been developed to communicate with building automation systems that support the BACnet Application Specific Controller (B-ASC) device profile. A Lennox zone sensor, a BACnet network zone sensor, or a BACnet thermostat or DDC controller may be used to send the zone temperature or thermostat demands to the IMC.

The IMC BACnet Module is compatible with MSTP EIA-485 daisy-chain networks communicating at 38.4 kbps. It is compatible with twisted pair, shielded cable such as Lennox model nos. C0MISC00AE1-, C0MISC04AE1- or C0MISC01AE1- or Belden 8761, 88761. A maximum of 31 IMC BACnet Modules can be included per network. The BACnet MSTP maximum total bus length (without repeater) of 850 ft. (260m) applies to this device. A 120 ohm resistor must be added to the last module in the daisy chain (included in field kit).

C0CTRL50AE1L

NOTE: A qualified systems integrator with adequate training and experience is required to integrate and commission the IMC BACnet Module into a third-party BACnet building automation system. A BACnet network configuration software tool is required to commission the BACnet network.

INPUTS TO IMC

BACnet Object Name	Object Type: ID: Units	Description
Application Mode Control	AO: 101:95 (No_Units)	Unit application
0 - Auto		Auto (unit-defined operation)
1 - Heat		Demand for full Heating
3 - Cool		Demand for full Cooling
6 - Off		Unit Off (IMC stand by)
9 - Fan only		Main fan (blower) on
228 - Cool 1		Thermostat input Y1
232 - Cool 2		Thermostat input Y2
236 - Cool 3		Thermostat input Y1 & Y2
225 - Heat 1		Thermostat input W1
226 - Heat 2 (heat pump only)		Thermostat input W2 (heat pump emergency heat)
227 - Heat 3		Thermostat input W1 & W2
229 - Supermarket Reheat Lo		Thermostat input Y1 & W1
230 - Supermarket Reheat Hi		Thermostat input Y1 & W2
254 - Reset		Force controller reset
255 - Null		Same as auto.
Outdoor Air Min Pos Control	AO: 102 : 98 (Percent)	Min economizer damper position
Occupancy Override Control	AO: 103: 95 (No_Units)	Zone occupied status
Occupancy Scheduler Control	AO: 104: 95 (No_Units)	Occupancy scheduler input used to put controller unit into different occupancy modes.
Occupancy Sensor Input	AO: 107: 95 (No_Units)	Occupancy sensor input. Used to indicate the presence of occupants
Space Dehumidification Setpt	AO: 108: 98 (Percent)	Zone relative humidity set point
Temperature Setpoint (abs)	AO: 109: 64 (Degrees - Fahrenheit)	Zone temperature setpoint
Temperature Setpoint Offset	AO: 110: 64 (Degrees - Fahrenheit)	Zone temp setpoint offset
Space Temperature Input	AO: 113: 64 (Degrees - Fahrenheit)	Remote zone temp.
Emergency Override Control	AO: 114: 95 (No_Units)	Emergency smoke override
Compressor Enable Control	AO: 115: 98 (Percent)	Compressor enable
Primary Heat Enable Control	AO: 117: 98 (Percent)	Primary heat enable
Auxiliary Heat Enable Control	AO: 119: 98 (Percent)	Auxiliary heat enable

OPTIONAL UNIT CONTROLLERS AND SYSTEMS INTEGRATION

IMC BACNET® MODULE (Continued)

OUTPUTS FROM IMC

OUTPUTS FROM IMC		
IMC Version [00].....[07]	AI: 200-207 : 95 (No_Units)	IMC firmware version. (null terminated ASCII)
Unit ID	AI: 231 : 95 (No_Units)	Unit ID \$3x-Gas/Elect. \$4x-Elect/Elect. \$5x-Heat Pump
Unit Status	AI :232 : 95 (No_Units)	Unit operation mode (i.e. cool, heat, etc.)
1 - HVAC heat		
2 - HVAC morning warm-up		
3 - HVAC cool		
5 - HVAC pre-cool		
6 - HVAC off		
7 - HVAC test		
8 - HVAC emergency heat		
9 - HVAC fan only		
12 - HVAC max heat		
14 - HVAC dehumidification		
129 - HVAC fresh air heating		
131 - HVAC fresh air cooling		
145 - HVAC defrost 1		
161 - HVAC defrost 2		
177 - HVAC defrost 1, 2		
Space Temperature	AI: 239 : 64 : 95 (Degrees - Fahrenheit))	
Discharge Air Temperature	AI: 240 : 64 (Degrees - Fahrenheit)	Supply air temperature
Effective Occupancy	AI : 241 : 95 (No_ Unit)	Zone occupied status
Local Outside Air Temperature	AI 242 : 64 (Degrees - Fahrenheit)	Outdoor air temperature
Local Space Temperature	AI: 243 :64 (Degrees Fahrenheit)	Zone Temperature, local
Outside Air Damper	AI: 244 : 98 (Percent)	Economizer damper position
Heat Primary	AI: 245 :98 (Percent)	Primary heating status
Heat Secondary	AI: 246 : 98 (Percent)	Heat pump electric strip heating status
Cool Primary	AI: 247 : 98 (Percent)	Cooling compressor 1-4 status (on/off)
Economizer Enabled	AI: 248 : 95 (Percent)	Economizer outdoor air suitable
Supply Fan Status	AI: 250 : 98 (Percent)	Supply fan status
Space Temperature Set Point (Eff)	AI: 252 :64 (Degrees Fahrenheit)	Zone temperature set points
Current Error	AI: 253 : 95 (No_Units)	Currently displayed error code
Error Pointer	AI: 254 : 95 (No_Units)	Error pointer. This value points to the next available alarm code location. It runs from 0 to 83 and then rolls-over to 0. Tracking this value and using the ten most recent error codes (below) allows an application to determine when new errors are logged by the IMC, what those errors are, and if any errors have been missed due to network delays or for any other reason.
Most recent Error 1..10	AI: 255-264 : 95 (No_Units)	IMC alarm codes as listed in the IMC manual.
Space CO2 Sensor (Local)	AI : 274 :96 (Parts per million)	Zone CO ₂ level (PPM), local
Space Humidity (Local)	AI: 276 : 98 (Percent)	Zone relative humidity, local
Dehumidification Set Point (Eff)	AI: 278 : 98 (Percent)	Zone relative humidity set point
Dehumidification Status	AI: 279 : 95 (No_Units)	Dehumidification status
Return Air Temperature	AI: 281 :64 (Degrees Fahrenheit))	Return air temperature
Building Static Pressure	AI: 282 : 64 (Inches of water)	Analog Input 2 (GP1 - VAV Bldg Static)
Duct Static Pressure	AI: 282 : 64 (Inches of water)	Analog Input 1 (GP1 - VAV Supply Static)
Exhaust Fan Status	AI: 285 :98 (Percent)	Exhaust fan status
Controller Online	B1:100 :95 (No_Units)	IMC Communicating

OPTIONAL CONVENTIONAL TEMPERATURE CONTROL SYSTEMS - FIELD INSTALLED

COMMERCIAL TOUCHSCREEN THERMOSTAT



Intuitive Touchscreen Interface - **Two Stage Heating / Two Stage Cooling Conventional or Heat Pump** - Seven Day Programmable - Four Time Periods/Day - Economizer Output - Title 24 Compliant - ENERGY STAR® Qualified - Backlit Display - Automatic Changeover

C0STAT02AE1L

Sensors For Touchscreen Thermostat

¹ Remote non-adjustable wall mount 20k temperature sensor	C0SNZN01AE2-
¹ Remote non-adjustable wall mount 10k averaging temperature sensor	C0SNZN73AE2-
¹ Remote non-adjustable duct mount temperature sensor	C0SNDC00AE1-
Outdoor temperature sensor	C0SNSR03AE1-

Accessories For Touchscreen Thermostat

Locking cover (clear)	C0MISC15AE1-
-----------------------------	--------------

¹ Remote sensors for C0STAT02AE1L can be applied in the following combinations: (1) C0SNZN01AE1-, (2) C0SNZN73AE1-, (2) C0SNZN01AE1- and (1) C0SNZN73AE1-, (4) C0SNZN01AE1-, (3) C0SNZN01AE1- and (2) C0SNZN73AE1.

DIGITAL NON-PROGRAMMABLE THERMOSTATS



Intuitive Interface - Automatic Changeover - Simple Up and Down Temperature Control

Two-stage heating / cooling conventional systems	C0STAT10AE1L
---	--------------

Sensor For Digital Non-Programmable Thermostats Above

Remote wall mounted temperature sensor	C0SNZN00AE1-
--	--------------



Intuitive Interface - Automatic Changeover - Backlit Display - Simple Up and Down Temperature Control

One-stage heating / cooling conventional systems	C0STAT12AE1L
---	--------------

Sensor For Digital Non-Programmable Thermostats Above

Outdoor temperature sensor	C0SNSR04AE1-
----------------------------------	--------------

Accessories For Digital Non-Programmable Thermostats Above

Optional wall mounting plate	C0MISC17AE1-
------------------------------------	--------------

WEIGHT DATA

Model Number	Net		Shipping	
	lbs.	kg	lbs.	kg
090/102 Base Unit	1300	590	1385	628
090/102 Max. Unit	1525	692	1610	730
120 Base Unit	1355	615	1440	653
120 Max. Unit	1580	717	1665	755
150 Base Unit	1390	630	1475	669
150 Max. Unit	1615	733	1700	771

OPTIONS / ACCESSORIES

		Weight	
		lbs.	kg.
CEILING DIFFUSERS			
Step-Down	RTD11-95	88	40
	RTD11-135	205	93
	RTD11-185	392	178
Flush	FD11-95	75	34
	FD11-135	174	79
	FD11-185	289	131
Transitions	LASRT08/10	30	14
	LASRT10/12	32	15
	LASRT15	36	16

ECONOMIZER / OUTDOOR AIR / EXHAUST

Economizer	LAREMD10/15	47	21
Barometric Relief			
Down-Flow Barometric Relief Dampers	LAGED10/15	8	4
Horizontal Barometric Relief Dampers	LAGEDH18/24	20	9
Outdoor Air Dampers			
Damper Section (down-flow) - Automatic	LAOADM10/15	31	14
Damper Section (down-flow) - Manual	LAOAD10/15	26	12
Outdoor Air Hood (down-flow)	LAOAH10/15	11	5
Power Exhaust	LAPEF10/15	28	13

PACKAGING

LTL Packaging (less than truck load)		105	48
--------------------------------------	--	-----	----

ROOF CURBS - CLIPLOCK 1000

Down-Flow			
14 in. (356 mm) height	LARMF10/15S-14	115	52
18 in. (457 mm) height	LARMF10/15S-28	156	71
24 in. (610 mm) height	LARMF10/15S-24	189	86

ROOF CURBS - STANDARD

Down-Flow			
14 in. (356 mm) height	LARMF10/15-14	126	57
24 in. (610 m) height	LARMF10/15-24	174	79

Base Unit - The unit with low fire heat exchanger NO OPTIONS.

Max. Unit - The unit with ALL OPTIONS Installed. (High Input Heat Exchanger, Economizer, Power Exhaust Fans, Controls)

DIMENSIONS - INCHES (MM)

Model Number	CORNER WEIGHTS								CENTER OF GRAVITY			
	AA		BB		CC		DD		EE		FF	
	lbs.	kg	lbs.	kg	lbs.	kg	lbs.	kg	inch	mm	inch	mm
090/102 Base Unit	314	142	289	131	329	149	368	167	47	1194	21-1/2	546
090/102 Max. Unit	381	173	339	154	374	170	431	195	46	1168	23-1/2	597
120 Base Unit	328	149	300	136	343	156	384	174	47	1194	21-1/2	546
120 Max. Unit	394	179	352	160	387	176	447	203	46	1168	23-1/2	597
150 Base Unit	336	152	312	152	353	160	389	176	47-1/2	1207	22	559
150 Max. Unit	403	183	364	165	398	181	450	204	46-1/2	1181	24	610

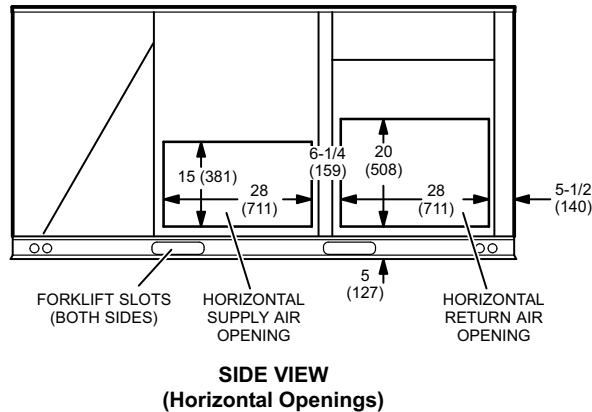
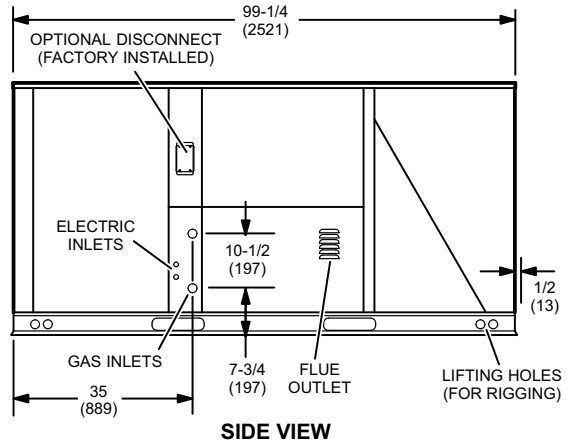
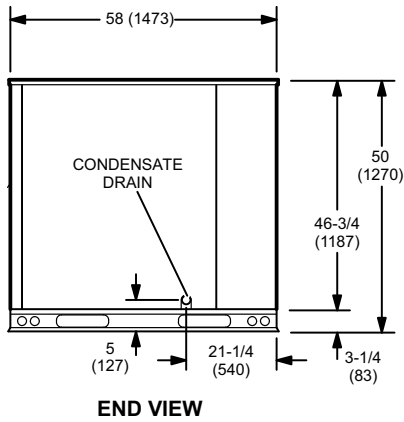
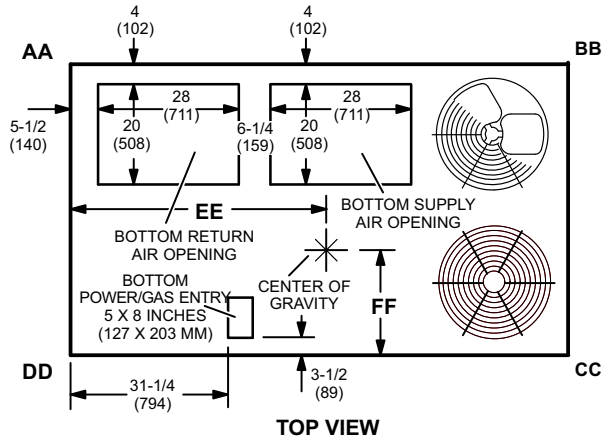

OPTIONAL OUTDOOR AIR HOOD DETAIL

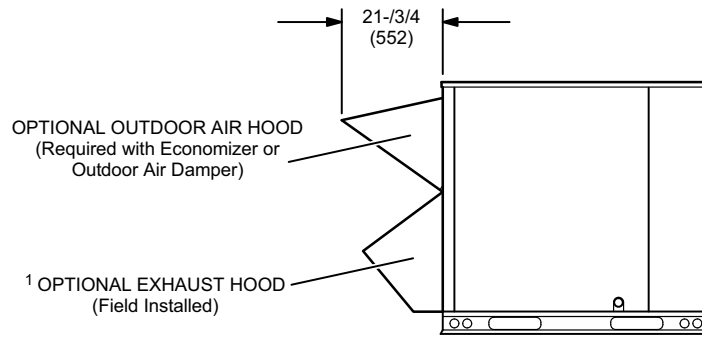

¹ NOTE — Field Installed in Return Air Duct for Horizontal Applications.

HORIZONTAL BAROMETRIC RELIEF DAMPERS
(Field installed in horizontal return air duct adjacent to unit)

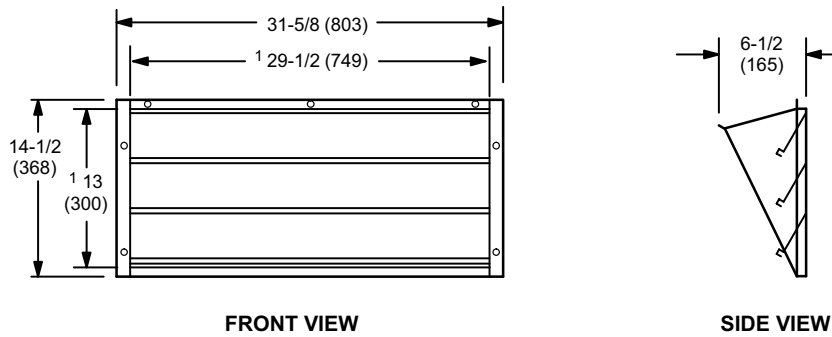

¹ NOTE - Opening size required in return air duct.

ACCESSORY DIMENSIONS - INCHES (MM)

CLIPLOCK 1000 ROOF CURBS - DOUBLE DUCT OPENING

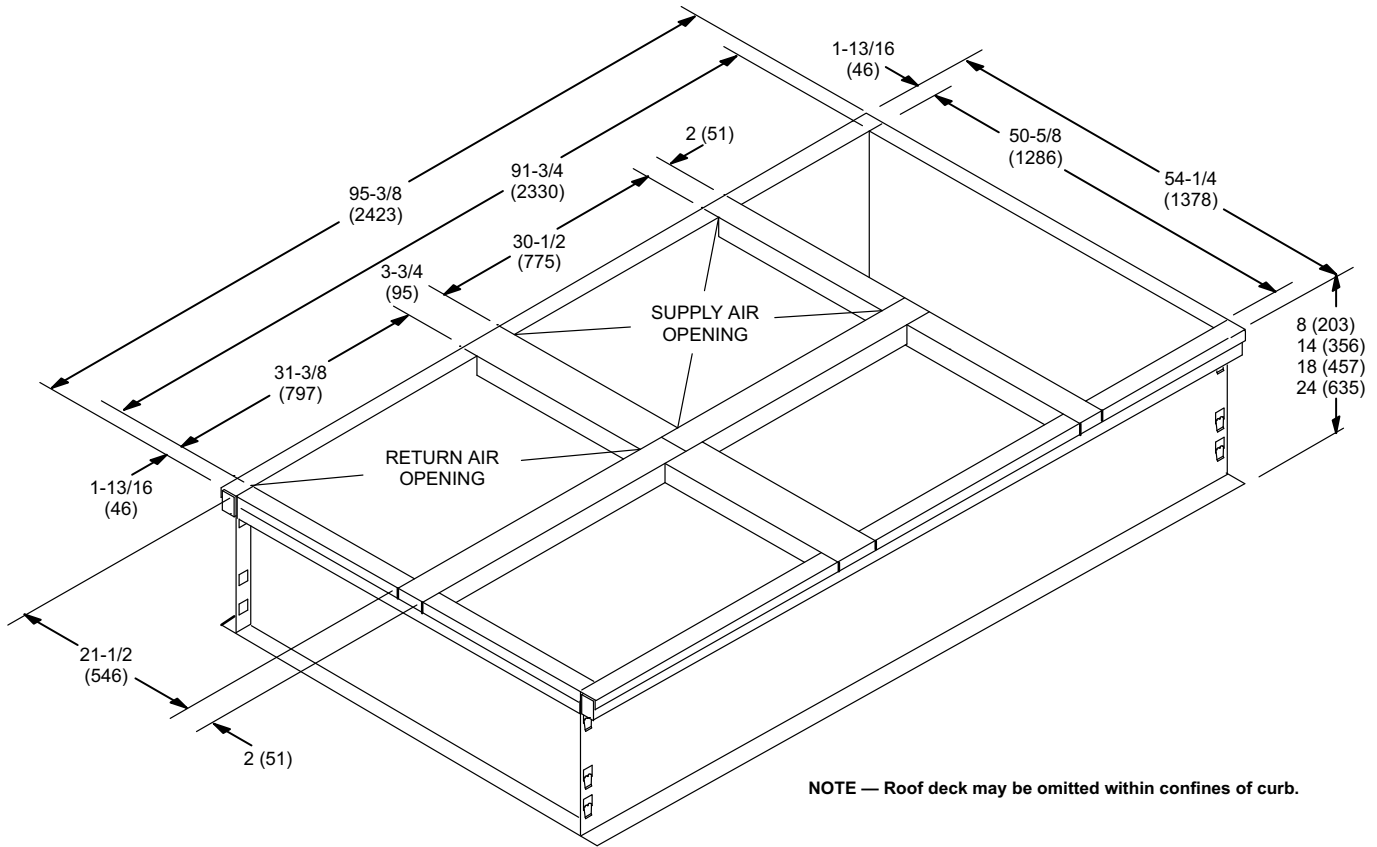

TYPICAL FLASHING DETAIL FOR ROOF CURB

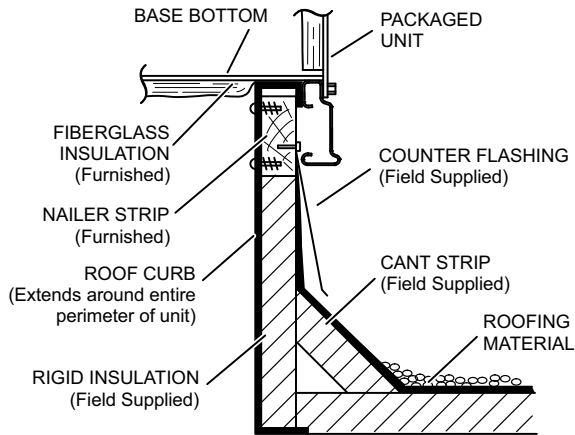

DETAIL ROOF CURB

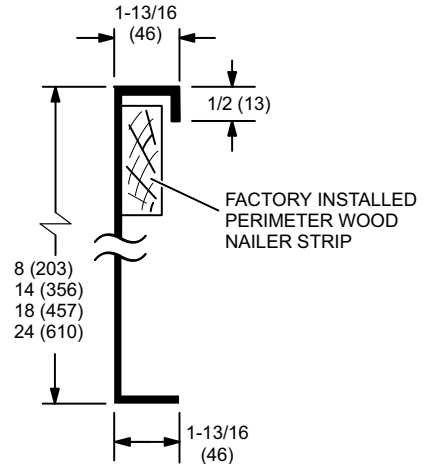

ACCESSORY DIMENSIONS - INCHES (MM)

STANDARD ROOF CURBS - DOUBLE DUCT OPENING

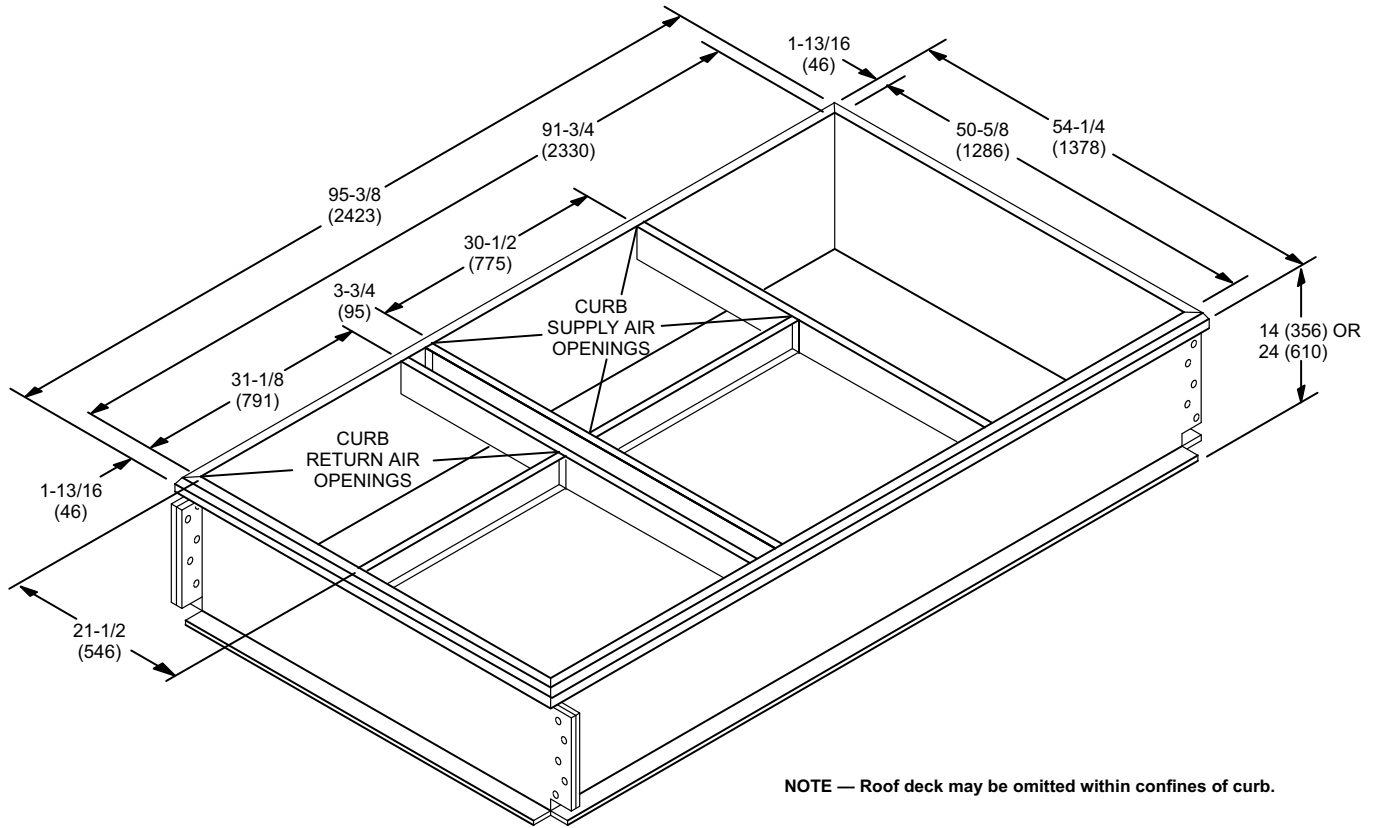

NOTE — Roof deck may be omitted within confines of curb.

TYPICAL FLASHING DETAIL FOR ROOF CURB

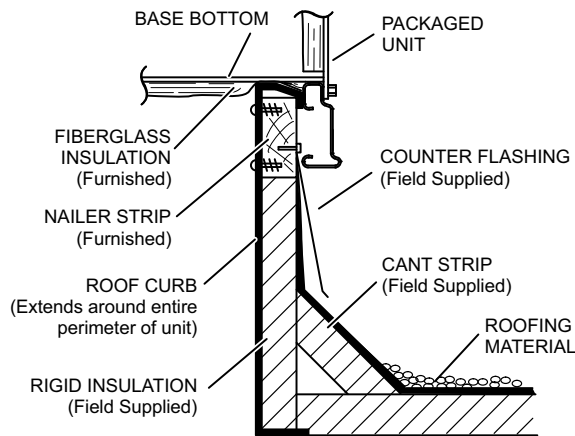

DETAIL ROOF CURB

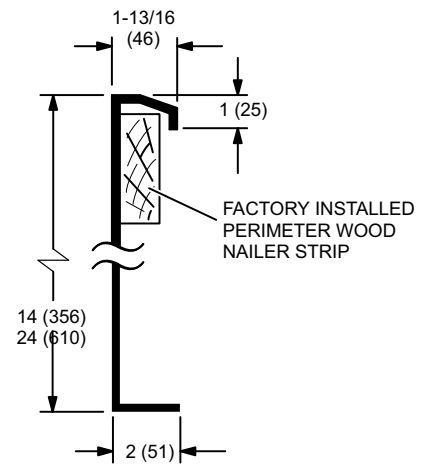

ACCESSORY DIMENSIONS - INCHES (MM)

ROOF CURBS WITH SUPPLY & RETURN AIR TRANSITIONS FOR CEILING DIFFUSERS

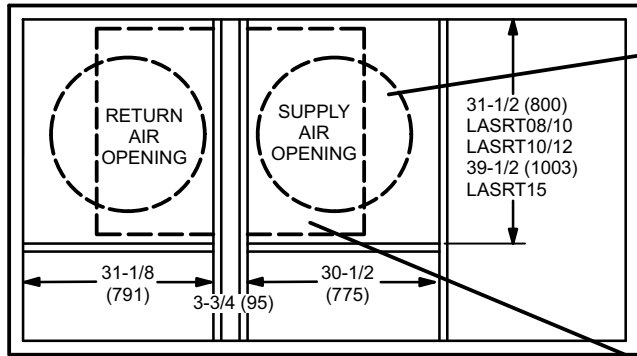

TOP VIEW

LASRT08/10 ROUND TRANSITIONS
(for 090 models with FD11-95, RTD11-95 Diffusers)

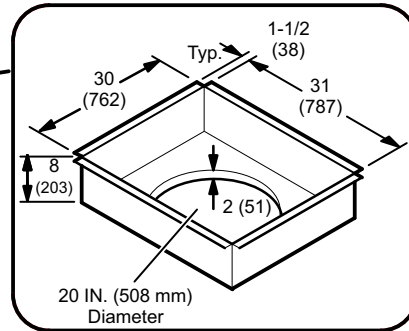

LASRT10/12 & LASRT15 RECTANGULAR TRANSITIONS
(for 102 thru 150 models with FD11-135-185, RTD11-135-185 Diffusers)

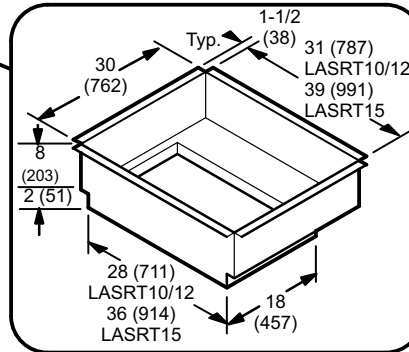

ACCESSORY DIMENSIONS - INCHES (MM)

COMBINATION CEILING SUPPLY AND RETURN DIFFUSERS

STEP-DOWN CEILING DIFFUSER

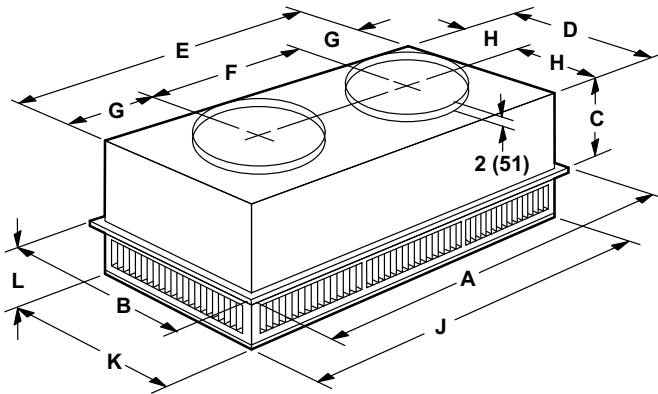

Model Number		RTD11-95
A	in.	47-5/8
	mm	1159
B	in.	29-5/8
	mm	752
C	in.	14-3/8
	mm	365
D	in.	27-1/2
	mm	699
E	in.	45-1/2
	mm	1158
F	in.	22-1/2
	mm	572
G	in.	11-1/2
	mm	292
H	in.	13-3/4
	mm	349
J	in.	45-1/2
	mm	1156
K	in.	27-1/2
	mm	699
L	in.	8-1/8
	mm	206
Duct Size	in.	20 round
	mm	508 round

FLUSH CEILING DIFFUSER

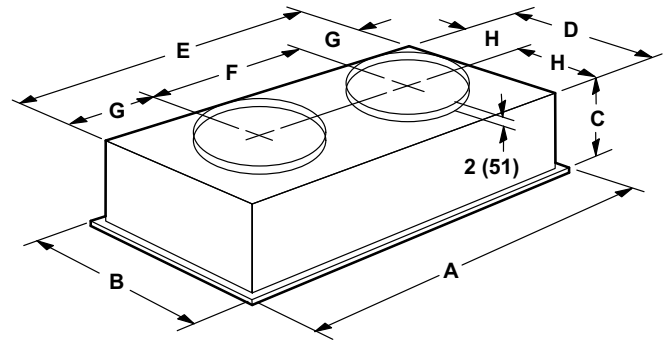

Model Number		FD11-95
A	in.	47-5/8
	mm	1159
B	in.	29-5/8
	mm	752
C	in.	16-5/8
	mm	422
D	in.	27
	mm	686
E	in.	45
	mm	1143
F	in.	22-1/2
	mm	572
G	in.	11-1/4
	mm	286
H	in.	13-1/2
	mm	343
Duct Size	in.	20 round
	mm	508 round

ACCESSORY DIMENSIONS - INCHES (MM)

COMBINATION CEILING SUPPLY AND RETURN DIFFUSERS

STEP-DOWN CEILING DIFFUSER

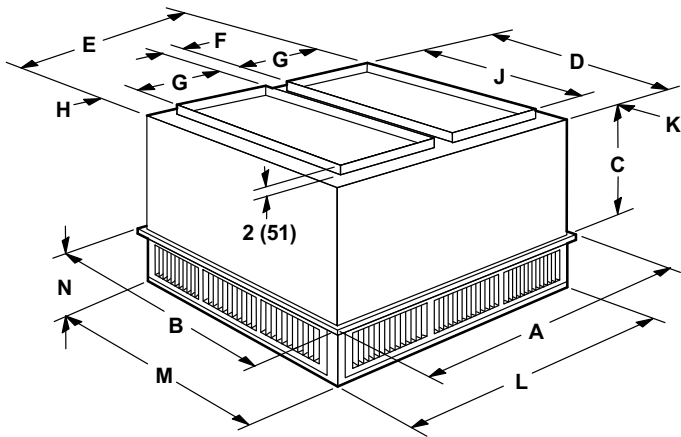

FLUSH CEILING DIFFUSER

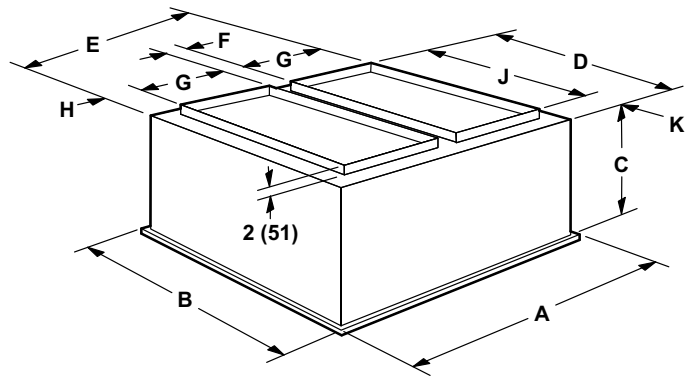

Model Number		RTD11-135	RTD11-185
A	in.	47-5/8	47-5/8
	mm	1210	1210
B	in.	35-5/8	47-5/8
	mm	905	1210
C	in.	20-5/8	24-5/8
	mm	524	625
D	in.	33-1/2	45-1/2
	mm	851	1156
E	in.	45-1/2	45-1/2
	mm	1156	1156
F	in.	4-1/2	4-1/2
	mm	114	114
G	in.	18	18
	mm	457	457
H	in.	2-1/2	2-1/2
	mm	64	64
J	in.	28	36
	mm	711	914
K	in.	2-3/4	4-3/4
	mm	70	121
L	in.	45-1/2	45-1/2
	mm	1156	1156
M	in.	33-1/2	45-1/2
	mm	851	1156
N	in.	9-1/8	10-1/8
	mm	232	257
Duct Size	in.	18 x 28	18 x 36
	mm	457 x 711	457 x 914

Model Number		FD11-135	FD11-185
A	in.	47-5/8	47-5/8
	mm	1210	1210
B	in.	35-5/8	47-5/8
	mm	905	1210
C	in.	23-1/4	29-1/4
	mm	591	743
D	in.	33	45
	mm	838	1143
E	in.	45	45
	mm	1143	1143
F	in.	4-1/2	4-1/2
	mm	114	114
G	in.	18	18
	mm	457	457
H	in.	2-1/4	2-1/4
	mm	57	57
J	in.	28	36
	mm	711	914
K	in.	2-1/2	4-1/2
	mm	64	114
Duct Size	in.	18 x 28	18 x 36
	mm	457 x 711	457 x 914

GUIDE SPECIFICATIONS

This specification is for [*Lennox Industries L Series®*] rooftop units. Revise specification section number and title below to suit project requirements, specification practices and section content. Refer to CSI *MasterFormat™* for other section numbers and titles.

Optional text and text that requires a decision are indicated by **bold brackets []** and proprietary information is indicated by **bold italic brackets []**; delete text that is not needed in final copy of specification. Specifier Notes typically precede specification text; delete notes in final copy of specification. Trade/brand names with appropriate symbols typically are used in Specifier Notes; symbols are not used in specification text. Metric conversion, where used, is soft metric conversion.

Specifying Engineer Please Note - These Guide Specifications cover all L Series units (3 thru 30 tons). Please edit to accurately identify the options selected for the job.

SECTION 23 74 33 UNITARY AIR CONDITIONING EQUIPMENT

PART 1 GENERAL

PART 1.01 SUMMARY

- A. Section Includes: Packaged rooftop units and commercial packaged, gas/electric and electric/electric heat pumps.

Specifier Note: Revise paragraph below to suit project requirements. Add section numbers and titles per CSI MasterFormat and specifier's practice.

- B. Related Sections:

Specifier Note: Article below may be omitted when specifying manufacturer's proprietary products and recommended installation. Retain Reference Article when specifying products and installation by an industry reference standard. If retained, list standard(s) referenced in this section. Indicate issuing authority name, acronym, standard designation and title. Establish policy for indicating edition date of standard referenced. Conditions of the Contract or Division 1 References Section may establish the edition date of standards. This article does not require compliance with standard, but is merely a listing of references used. Article below should list only those industry standards referenced in this section. Retain only those reference standards to be used within the text of this Section. Add and delete as required for specific project.

PART 1.02 REFERENCES

- A. American National Standards Institute (ANSI):
1. ANSI/ASHRAE 15 Safety Standard for Refrigeration Systems.
 2. ANSI/ASHRAE/IESNA 90.1 Energy Efficient Design of New Buildings Except Low-Rise Residential Buildings.
 3. ANSI Z21.47 Gas-Fired Central Furnaces.
- B. Air-Conditioning and Refrigeration Institute (ARI):
1. ARI 210/240 Unitary Air-Conditioning and Air-Source Heat Pump Equipment.
 2. ARI 270 Sound Rating of Outdoor Unitary Equipment.
 3. ARI 340/360 Commercial and Industrial Unitary Air-Conditioning and Heat Pump Equipment.
 4. ARI 370 Sound Rating of Large Outdoor Refrigerating and Air Conditioning Equipment.
- C. American Society of Heating, Refrigerating, and Air-Conditioning Engineers, Inc. (ASHRAE):
1. ASHRAE 52.2 Method of Testing General Ventilation Air-Cleaning Devices for Removal Efficiency by Particle Size (ANSI approved).
 2. ASHRAE 62.1 Ventilation for Acceptable Indoor Air Quality.
- D. U.S. Energy Policy Act of 1992 (EPACT).
- E. U.S. National Appliance Energy Conservation Act (NAECA):
1. NAECA 1988.
- F. National Fire Protection Association (NFPA):
1. NFPA 90A Installation of Air Conditioning and Ventilation Systems.
- G. Underwriters Laboratories, Inc. (UL):
1. UL 1995 Standard for Safety for Heating and Cooling Equipment.

GUIDE SPECIFICATIONS

Specifier Note: Article below should be restricted to statements describing design or performance requirements and functional (not dimensional) tolerances of a complete system. Limit descriptions to composite and operational properties required to link components of a system together and to interface with other systems.

PART 1.03 SYSTEM DESCRIPTION

- A. Design Requirements: Provide products and systems that have been manufactured, fabricated and installed to following criteria:
1. ANSI/ASHRAE/IESNA 90.1.
 2. ANSI Z21.47.
 3. UL 1995.
- B. Performance Requirements:
1. Packaged Gas Electric:
 - a. Natural Gas Supply Pressure: 7 in. w.c. (1.7 kPa).

Specifier Note: For belt drive blowers from models LGC036S, LGA036H, LGC042S, LGA042H, LGC048S, LGA048H, LGC060S, LGA060H, LGC072S, LGA072H, LGC090S, LGA090H, LGC102S, LGA102H, LGC120S, LGA120H, LGC150S, LGC156H, LGC180S, LGC180H, LGC210S, LGC210H, LGC240S, LGA240H, LGA248H, LGC300S, LGC300H and LGC360H single phase is not an option.

- b. LPG/Propane Supply Pressure: 11 in. w.c. (2.7 kPa).

Specifier Note: Specify 208/230V or 460V or 575V, 3-phase for L Series units from 6 - 30 ton (21.1 - 105.6 kW). Specify 208/230V, 1-phase, 208/230V, 460V or 575V, 3-phase for L Series units from 3 - 5 ton (10.6 - 17.6 kW).

2. Packaged Cooling:

Specifier Note: For belt drive blowers from models LCC036S, LCA036H, LCC042S, LCA042H, LCC048S, LCA048H, LCC060S, LCA060H, LCC072S, LCA072H, LCC090S, LCA090H, LCC102S, LCA102H, LCC120S, LCA120H, LCC150S, LCC156H, LCC180S, LCC180H, LCC210S, LCC210H, LCC240S, LCA240H, LCA248H, LCC300S, LCC300H and LCC360H single phase is not an option.

- b. Electrical Requirements for Belt Drive Blowers: 60 hz, [208/230 V, 3-phase] [460 V, 3-phase] [575 V, 3-phase].

Specifier Note: Available Heat Pump units include LHA090, LHA102, LHA120, LHA150, LHA180 and LHA240 only.

3. Packaged Heat Pumps:
 - a. Electrical Requirements: 60 hz, [208/230 V, 3-phase] [460 V, 3-phase] [575 V, 3-phase].
4. ARI Rated Net Cooling Efficiency: To meet or exceed ASHRAE Standard 90.1 at rated airflow not less than 350 cfm/ton.

Specifier Note: Article below includes submittal of relevant data to be furnished by Contractor before, during or after construction. Coordinate this article with Architect's and Contractor's duties and responsibilities in Conditions of the Contract and Division 1 Submittal Procedures Section.

PART 1.04 SUBMITTALS

- A. General: Submit listed submittals in accordance with Conditions of the Contract and Division 1 Submittal Procedures.
- B. Product Data: Submit product data for specified products.
- C. Shop Drawings:
1. Submit shop drawings in accordance with Section 01 33 23 - Submittal Procedures.
 2. Indicate:
 - a. Equipment, piping and connections, together with valves, strainers, control assemblies, thermostatic controls, auxiliaries and hardware, and recommended ancillaries which are mounted, wired and piped ready for final connection to building system, its size and recommended bypass connections.
 - b. Piping, valves and fittings shipped loose showing final location in assembly.
 - c. Control equipment shipped loose, showing final location in assembly.
 - d. Dimensions, internal and external construction details, recommended method of installation with proposed structural steel support, mounting curb details, sizes and location of mounting bolt holes; include mass distribution drawings showing point loads.
 - e. Detailed composite wiring diagrams for control systems showing factory installed wiring and equipment on packaged equipment or required for controlling devices or ancillaries, accessories and controllers.

GUIDE SPECIFICATIONS

- f. Details of vibration isolation.
 - g. Estimate of sound levels to be expected across individual octave bands in dB.
 - h. Type of refrigerant used.
- D. Quality Assurance:
- 1. Test Reports: Certified test reports showing compliance with specified performance characteristics and physical properties.
 - 2. Certificates: Product certificates signed by manufacturer certifying materials comply with specified performance characteristics and criteria and physical requirements.
 - 3. Manufacturer's Instructions: Manufacturer's installation instructions.

Specifier Note: Coordinate paragraph below with Part 3 Field Quality Requirements Article herein. Retain or delete as applicable.

- E. Manufacturer's Field Reports: Manufacturer's field reports specified.
- F. Closeout Submittals: Submit the following:
- 1. Warranty: Warranty documents specified.
 - 2. Operation and Maintenance Data: Operation and maintenance data for installed products in accordance with Division 1 Closeout Submittals (Maintenance Data and Operation Data) Section. Include methods for maintaining installed products and precautions against cleaning materials and methods detrimental to finishes and performance. Include names and addresses of spare part suppliers.
 - 3. Provide brief description of unit, with details of function, operation, control and component service.
 - 4. Commissioning Report: Submit commissioning reports, report forms and schematics in accordance with Section 01 91 00 - Commissioning.

PART 1.05 QUALITY ASSURANCE

- A. Qualifications:
- 1. Installer experienced in performing work of this section who has specialized in installation of work similar to that required for this project.
 - 2. Manufacturer Qualifications: Manufacturer capable of providing field service representation during construction and approving application method.

Specifier Note: Paragraph below should list obligations for compliance with specific code requirements particular to this section. General statements to comply with a particular code are typically addressed in Conditions of the Contract and Division 1 Regulatory Requirements Section. Repetitive statements should be avoided. Current data on building code requirements and product compliance may be obtained from filter manufacturer technical support specialists.

- B. Regulatory Requirements: Provide **[Packaged gas electric] [Packaged cooling] [Packaged heat pump]** that complies with the following requirements:
- 1. ARI 210/240.
 - 2. ARI 270.
 - 3. ARI 340/360.
 - 4. ASHRAE 52.2.
 - 5. NFPA 90A.
- C. Preinstallation Meetings: Conduct preinstallation meeting to verify project requirements, manufacturer's installation instructions and manufacturer's warranty requirements. Comply with Division 1 Project Management and Coordination (Project Meetings).

PART 1.06 DELIVERY, STORAGE & HANDLING

- A. General: Comply with Division 1 Product Requirements.
- B. Ordering: Comply with manufacturer's ordering instructions and lead time requirements to avoid construction delays.
- C. Packing, Shipping, Handling and Delivery:
- 1. Deliver materials in manufacturer's original, unopened, undamaged containers with identification labels intact.
 - 2. Ship, handle and unload units according to manufacturer's instructions.
- D. Storage and Protection:
- 1. Store materials protected from exposure to harmful weather conditions.
 - 2. Factory shipping covers to remain in place until installation.

PART 1.07 PROJECT CONDITIONS

GUIDE SPECIFICATIONS

- A. Installation Location: **[Confirm design conditions and temperature.]**.

Specifier Note: Coordinate article below with Conditions of the Contract and with Division 1 Closeout Submittals (Warranty).

PART 1.08 WARRANTY

- A. Project Warranty: Refer to Conditions of the Contract for project warranty provisions.
- B. Manufacturer's Warranty: Submit, for Owner's acceptance, manufacturer's standard warranty document executed by authorized company official. Manufacturer's warranty is in addition to, and not a limitation of, other rights Owner may have under Contract Documents.

Specifier Note: Coordinate paragraph below with manufacturer's warranty requirements.

- C. Warranty: Commencing on Date of Installation.
1. Compressors: 5 years (limited).
 2. Integrated Modular Control: 3 years (limited).
 3. Other System Components: 1 year (limited).
 4. Aluminized Heat Exchangers: 10 years (limited).
 5. Stainless Steel Heat Exchangers: 15 years (limited).

PART 2 PRODUCTS

Specifier Note: Retain article below for proprietary method specification. Add product attributes, performance characteristics, material standards and descriptions as applicable. Use of such phrases as "or equal" or "or approved equal" or similar phrases may cause ambiguity in specifications. Such phrases require verification (procedural, legal and regulatory) and assignment of responsibility for determining "or equal" products.

PART 2.01 ROOFTOP UNITS

- A. Manufacturer: Lennox Industries Inc.
1. Contact: 2100 Lake Park Blvd., Richardson, TX 75080; Telephone: (800) 453-6669; website: www.lennox.com.
- B. Proprietary Products/Systems: Lennox L Series Unitary Air Conditioning Equipment, including the following equipment:
1. Cabinet: Weatherproofing tested and certified to AGA **[Rain test standards]** and soundproofing tested to ARI 270, **[]** dbA at **[]** m (**[]**) ft. free field.
 - a. Heavy gauge steel panels and full perimeter heavy gauge galvanized steel base rails.
 - b. Raised edges around duct and power entry openings in bottom of unit.
 - c. Airflow Configuration: **[Down-flow (vertical) return air] [Horizontal return airflow with Horizontal Roof Mounting Frame] [And Horizontal Return Air Panel Kit (required when converting down-flow configured unit to horizontal airflow)]**.
 - d. Power Entry: Electrical **[And gas]** lines brought through unit base or through horizontal access knockouts.
 - e. Exterior Panels: Constructed of heavy gauge, galvanized steel with 2-layer enamel paint finish.
 - f. Insulation: All panels adjacent to conditioned air fully insulated with non-hygroscopic fiberglass insulation. Unit base fully insulated.
 - g. Base Rail: Full perimeter base rail with rigging holes; 3 sides with fork slots.
 - h. Access Panels: Hinged for compressor/controls/heating areas, blower access and air filter/economizer access; and, sealed with quarter-turn latching handles and tight air and water seal.
 2. Compressor:
 - a. Copeland scroll type, hermetically sealed.
 3. Fans, General: Centrifugal, forward curved impellers, statically and dynamically balanced. **[Multi]** V-belt drive with adjustable variable pitch motor pulley.
 - a. Condenser Fan: Low sound operating, PVC coated fan guard, direct drive propeller type fans to discharge vertically.
 - b. Condenser Fan Motor: Permanently lubricated, permanent split capacitor; totally enclosed from weather, dust and corrosion; permanently lubricated ball bearings; resiliently mounted; overload protected.
 4. Evaporator Coils: Pressure and leak tested to 500 psi (3445 kPa), nonferrous coils with enhanced aluminum fins mechanically bonded to durable copper tubes.
 5. Condenser Coils:
 - a. Pressure and leak tested to 500 psi (3445 kPa), nonferrous coils with enhanced aluminum fins mechanically bonded to durable copper tubes.

GUIDE SPECIFICATIONS

Specifier Note: Specify slab construction for L Series over 6 tons (21.1 kW), excluding heat pumps.

- b. **[Formed construction] [Slab construction].**
- 6. Air Distribution:
 - a. Equipment capable of down-flow (vertical) or side (horizontal) handling of conditioned air.
 - b. Optional Equipment:

Specifier Note: The following kit is required for horizontal air handling for L Series 3 - 12 ton (10.6 - 42.2 kW) models.

- 1) Horizontal conversion kit for horizontal air handling.

Specifier Note: The following kit is required for horizontal air handling for L Series, 13 - 30 ton (45.8 - 105.6 kW) models.

- 2) Horizontal return air panel kit and horizontal roof mounting frame for horizontal air handling.
- 7. Filters: To meet NFPA 90A, air filter requirements **[Type Class 1] [Type Class 2]; [_____] % efficiency, metal framed, [Replaceable media] [Throwaway] [Standard to unit manufacturer].**
 - a. Disposable 2 inch (51 mm).
 - b. Disposable 2 inch (51 mm) pleated MERV 11 rated.
 - c. Disposable 2 inch (51 mm) pleated MERV 15 rated.
- 8. Heat Exchanger: Removable for servicing; stainless steel optional for applications where mixed air temperature below 45 degrees F (7 degrees C); E.T.L./C.S.A. design certified for outdoor installation.
- 9. Gas Heating System:
 - a. Tubular heat exchanger and inshot type gas burners constructed of aluminized steel.
 - b. Direct spark ignition; electronic flame sensor controls; flame rollout switch; limit controls and automatic redundant dual gas valve with staging control and combustion air proving switch on combustion air inducer.

Specifier Note: When LPG/propane is required, specify optional kit.

- c. Able to use LPG/propane **[With optional kit].**
- d. Complete service access provided for controls and wiring.
- 10. Electric Heating System:
 - a. Available for factory or field installation.
 - b. Heating elements of Nichrome bare wire exposed directly to airstream.
- 11. Refrigeration System:
 - a. Self-sealing, discharge, suction and liquid line service gauge ports, freeze-stats, expansion valves and full refrigerant charge.

Specifier Note: R-22 is available on all models with 3 - 30 ton (10.6 - 105.6 kW) capacities. R-410 is available on all high efficiency units and on the 6, 12.5 and 25 ton (21.1, 44 and 87.9 kW) standard efficiency models. Variable air volume with R-410a is available on 21, 25 and 30 ton (74, 88 and 105.6 kW) units.

- b. **[R22] [R-410a] [Variable air volume] [Variable air volume with R-410a].**
- c. Copper tubing not to touch sharp metal surfaces.
- d. Compressor Circuits: Automatic reset, high pressure switch; automatic reset, low pressure switch; liquid line filter-drier.
- e. Capable of operating down to 0 degrees F (-17 degrees C) without installation of additional controls.
- 12. Supply Air Blower:
 - a. **[Constant air volume with adjustable pulleys] [Variable air volume with fixed pulleys and variable frequency drive] [Variable air volume with fixed pulleys and variable frequency drive with bypass]** with motor/drive combinations and optional drive kits.
 - b. Centrifugal supply air blower with **[Permanently lubricated ball bearings and adjustable belt drive] [Sleeve bearings and multi-speed direct drive motor].**
 - c. Blower assembly **[Slides out of unit] [Is accessible]** for servicing.

Specifier Note: 3 to 6 ton (10.6 - 21.1 kW) blower is fixed.

- d. Blower wheel statically and dynamically balanced.

GUIDE SPECIFICATIONS

13. Integrated Modular Control (IMC):
 - a. Solid state control board to operate unit.
 - b. Built-in functions include: Blower on/off delay; built-in control parameter defaults; service relay output; dirty filter switch input; dehumidistat input, economizer control; **[Gas valve delay between stages]; [ETM compatible]; [DDC compatible];** unit diagnosis; diagnostics code storage; indoor air quality input; low ambient controls; minimum run time; night setback mode; smoke alarm mode; low pressure control; thermostat bounce delay; 3-digit display; degrees F or degrees C display, 2-stage heat/4-stage cool thermostat compatible and warm-up mode; **[Electric heat staging with optional 4-stage board].**
14. Gas Heating Controls:
 - a. Remote thermostat[s] as indicated.
 - b. Built-in **[Un]** fused disconnect switch.
 - c. **[Four]** stages of heating control from **[Thermostat with optional four stage board] [DDC with room sensor].**
 - d. Supply fan to turn on **[40]** seconds after heating demand is received with 8 - 60 second adjustable time delay.
 - e. Supply fan to turn off **[120]** seconds after heating demand has ended with 80 - 300 second adjustable time delay.
 - f. Adjustable delay time of **[30] [Value between 30 - 160]** seconds between low and high fire of 2-stage gas valve system.
 - g. Heat off delay of **[100] [Value between 30 - 300]** seconds after thermostat heating demand has ended.
 - h. To turn off heat and keep supply air fan running if overheat limit occurs.
 - i. Adjustable maximum overheat limit trip count during heating cycle of **[3] [Value between 1 - 15]**, with digital output, limit indicator.
 - j. To report error with each occurrence of overheat limit trip and to identify limit that tripped. Error code stored in nonvolatile memory.
 - k. To shut off gas heat if flame rollout occurs and to report error identifying rollout switch.
 - l. Maximum flame rollout switch trip count of **[3]** during heating cycle, with digital output, limit indicator. Maximum count limit adjustable from 1 - 6 counts.
 - m. To turn off heat if induced airflow is too low and to report error identifying pressure switch.
 - n. Maximum induced airflow pressure switch trip count of **[3]** during heating cycle, with digital output, limit indicator. Maximum count limit adjustable from 1 - 6 counts.
 - o. Error reported if gas valve not energized 2 minutes after heating demand; gas valve identified.
 - p. Maximum ignition failure count of **[3]** with digital output, limit indicator. Maximum count limit adjustable from 1 - 6 counts.
 - q. To shut off gas valve if flame not sensed. Error reported and stored in nonvolatile memory.
 - r. Delay between stages on gas valve.
 - s. To shut off unit if gas valve is energized with no demand for heat. Error reported and stored in nonvolatile memory.
15. Electric Heating Controls:
 - a. Panel board with **[_____]** stage controller.
 - b. Remote thermostat[s] as indicated.
 - c. Built-in **[Un]** fused disconnect switch.
 - d. Supply Fan: Start before electric elements are energized and continue operating until bonnet temperature reaches minimum setting. Include switch for continuous fan operation.
 - e. Two stages of heating control from **[Thermostat] [DDC].**
 - f. Supply fan to turn off **[20]** seconds after heating demand has ended. Time delay adjustable from 0 - 300 seconds.
 - g. With delay time of **[12]** seconds between low and high heat stages. Time delay adjustable from 12 - 60 seconds.
 - h. To turn off heat and keep supply air fan running if overheat limit occurs.
 - i. Adjustable maximum overheat limit trip count of **[3]** during heating cycle with digital output, limit indicator. Maximum count limit adjustable from 1 - 15 counts.
 - j. Error reported and identified if overheat limit tripped. Error code stored in nonvolatile memory.
16. Cooling Controls:
 - a. Provide **[Smoke detectors in return] [Smoke detectors in supply].**

GUIDE SPECIFICATIONS

Specifier Note: Specify b, c or d below.

- b. **[Manual] [Automatic]** outside **[And return]** air dampers for fixed outside air quantity.
- c. Remote controlled outside **[And return]** air dampers with damper operator and means for adjusting outside air quantity.
- d. Motorized outside, return and **[Automatic] [Power exhaust] [Gravity]** relief dampers with spring return damper operator and control package to automatically vary outside air quantity. Outside air and exhaust air dampers, normally closed.
- e. Tight-fitting parallel blade dampers with neoprene or suitable gaskets, synthetic bushings and 1% maximum leakage.
- f. Damper Operation: 24 V, spring return motor with gear train sealed in oil.
- g. Mixed Air Controls: **[Maintain 55 degrees F (13 degrees C)] [Indicated]** mixed air temperature (adjustable).
- h. Up to 2 stages of cooling from **[Thermostat] [External DDC controller]** without need for additional controls.
- i. Up to 3 stages of cooling when used with relay and **[3-stage thermostat] [DDC controller]**.
- j. Up to 4 stages of cooling standard with room sensor.

Specifier Note: Specify article "j" when used with Lennox L Connection Network Building Automation System.

- k. Up to 4 stages of cooling.
- l. To allow blower on delay of up to 60 seconds after cooling demand is received. Default value of zero.
- m. To allow blower off delay of up to 240 seconds after cooling demand has ended. Default value of zero.
- n. Minimum compressor on time of **[240]** seconds on 3-phase units, adjustable between 60 - 510 seconds.
- o. Minimum compressor off time of **[300]** seconds on single-phase units, adjustable from 60 - 510 seconds.
- p. Default maximum high pressure switch trip occurrence during cooling or dehumidification cycle of **[3]**. Trip occurrence limit adjustable from 1 - 8 occurrences. If maximum limit reached, compressor locked out and digital output for service activated.
- q. Default maximum low pressure switch trip occurrence during cooling or dehumidification cycle of **[3]**. Trip occurrence limit adjustable from 1 - 8 occurrences. If maximum limit reached, compressor locked out and digital output for service activated.
- r. Low pressure trip read delay of **[5]** minutes if compressor off time has been less than 4 hours and outdoor temperature is less than 70 degrees F (21 degrees C). Delay adjustable from 0 - 34 minutes. Temperature set point adjustable from 10 degrees F (-12 degrees C) to 100 degrees F (38 degrees C). Compressor off time adjustable from 1 - 6 hours.
- s. Low pressure trip read delay of **[15]** minutes if compressor off time has been 4 hours or greater and outdoor temperature is less than 70 degrees F (21 degrees C). Delay adjustable from 0 - 34 minutes. Temperature set point adjustable from 10 degrees F (-12 degrees C) to 100 degrees F (38 degrees C). Compressor off time adjustable from 1 - 6 hours.
- t. Low pressure trip read delay of **[2]** minutes if compressor off time has been less than 4 hours and outdoor temperature is 70 degrees F (21 degrees C) or greater. Delay adjustable from 0 - 34 minutes.
- u. Temperature set point adjustable from 10 degrees F (-12 degrees C) to 100 degrees F (38 degrees C). Compressor off time adjustable from 1 - 6 hours.
- v. Low pressure trip read delay of **[8]** minutes if compressor off time has been 4 hours or greater and outdoor temperature is 70 degrees F (21 degrees C) or greater. Delay adjustable from 0 - 34 minutes.
- w. Temperature set point adjustable from 10 degrees F (-12 degrees C) to 100 degrees F (38 degrees C). Compressor off time adjustable from 1 - 6 hours.
- x. Each pressure switch trip occurrence (either high or low) to record error in nonvolatile memory and identify compressor circuit.
- y. Low outdoor air temperature compressor lockout set point of 0 degrees F (-18 degrees C) for each compressor circuit. Low outdoor temperature limit set point individually adjustable for each compressor circuit from 80 degrees F (27 degrees C) to -30 degrees F (-34 degrees C).
- z. Maximum allowable evaporator freeze-stat trip occurrence of **[3]** during cooling demand with limit adjustable from 1 - 4 occurrences. Control to shut off compressor each time freeze-stat trip occurs and record error code in nonvolatile memory. If maximum limit reached, compressor locked out and digital output for service activated.
- aa. Condenser Fan Control:
 - 1) On units with multiple condenser fans, **[6]** second time delay between condenser fan shutoff and restart to prevent reverse rotation of fan. Time delay adjustable between 0 - 16 seconds.
 - 2) On units with 4 condenser fans, first stage low outdoor temperature set point of 55 degrees F (13 degrees C) that reduces airflow through condenser by turning off some fans. Set point adjustable between 60 degrees F (16 degrees C) and 10 degrees F (-12 degrees C).

GUIDE SPECIFICATIONS

- 3) On units with 6 condenser fans, second stage low outdoor temperature set point of 40 degrees F (4 degrees C) to reduce airflow through condenser by turning off all fans. Set point adjustable between 60 degrees F (16 degrees C) and 10 degrees F (-12 degrees C).
- 4) On units with 6 condenser fans, condenser fan on delay of **[2]** seconds. Adjustable between 0 - 240 seconds.

Specifier Note: Edit article below to suit project requirements. If substitutions are permitted, edit text below. Add text to refer to Division 1 Project Requirements (Product Substitutions Procedures) Section.

PART 2.02 PRODUCT SUBSTITUTIONS

- A. Substitutions: No substitutions permitted.

PART 3 EXECUTION

PART 3.01 MANUFACTURER'S INSTRUCTIONS

Specifier Note: Article below is an addition to the CSI SectionFormat and a supplement to MANU-SPEC. Revise article below to suit project requirements and specifier's practice.

- A. Compliance: Comply with manufacturer's written data, including product technical bulletins, product catalog installation instructions, and product carton installation instructions.

PART 3.02 EXAMINATION

- A. Site Verification of Conditions: Verify substrate conditions, which have been previously installed under other sections, are acceptable for product installation in accordance with manufacturer's instructions.

PART 3.03 INSTALLATION

- A. Install **[Packaged rooftop units] [And] [Commercial packaged, gas/electric and electric/electric heat pumps]** in accordance with manufacturer's instructions, on roof curbs **[Provided by manufacturer] [As indicated]**.
- B. Run drain line from cooling coil condensation drain pan to discharge **[Over roof drain]**.

PART 3.04 COMPLETION AND CLEANUP

- A. Upon completion and verification of performance of installation, remove surplus materials, excess materials, rubbish, tools and equipment.

END OF SECTION

AFTERMARKET ZONING SYSTEM INTERFACE

Introduction

Lennox' premium rooftop unit (RTU) controller, the Integrated Modular Controller (IMC), along with a variable frequency drive (VFD) option on certain RTUs, increases the ability of premium Lennox RTUs to be applied to a variety of zoning systems. The type of zoning system to be used dictates the type of RTU and the requirements for the zoning control system. The following explains each basic system and how the IMC must interface with an aftermarket zoning control system to meet the requirements of each application.

Lennox units in single zone and constant volume bypass applications may utilize an aftermarket unit controller as supervisory controller for the RTU. The IMC runs in thermostat mode and is primarily useful for diagnostic purposes, allowing the aftermarket controller to directly monitor and control heat/cool staging, the bypass damper, zone dampers, etc. When the IMC is used in thermostat mode, a maximum of two stage heating and three stage cooling are available.

Supervisory control must be provided by the Lennox IMC to minimize complication and standardize control on Lennox VFD-controlled variable air volume (VAV) RTUs. In this configuration, the IMC controls the VFD based on static pressure in the supply duct. It controls the economizer, and stages compressors based on discharge air temperature. The aftermarket controller simply sends calls for cooling or heating based on setpoint and schedule conditions. The IMC also has many options for controlling single-stage, 50% power exhaust fans; two-stage, 100% power exhaust fans; or modulating power exhaust fans.

NOTE - Please refer to the IMC Manual for additional details.

Interface Definition

With an aftermarket control system interface, the IMC requires four digital inputs to control the rooftop unit: G (blower enable), OCP (occupied), Y1 (enables discharge cooling), W1 (enables discharge heating) and Y2 (second stage call for cooling) and W2 (second stage call for heating) should be added in constant volume applications.

These configurations minimize the controls expertise required to create a viable interface. Further, they create a consistent, standardized approach conducive to support and trouble-shooting on a broad basis without the need for substantial knowledge of the IMC, VFD, bypass, or aftermarket controllers or systems.

AFTERMARKET ZONING SYSTEM INTERFACE

Constant Volume Bypass RTU Wiring Summary for units equipped with M1-6 or higher (Aftermarket Supervisory Control)

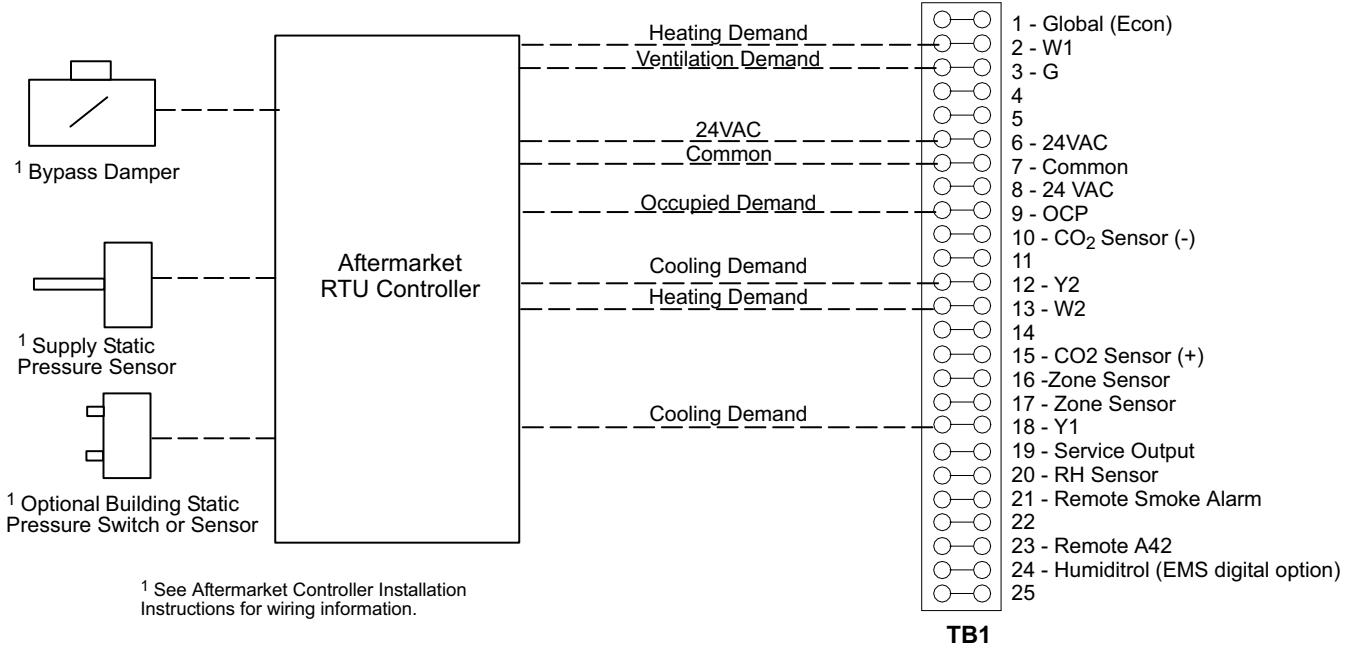

Variable Air Volume RTU Wiring Summary - for units equipped with M1-7 or higher (IMC Supervisory Control)

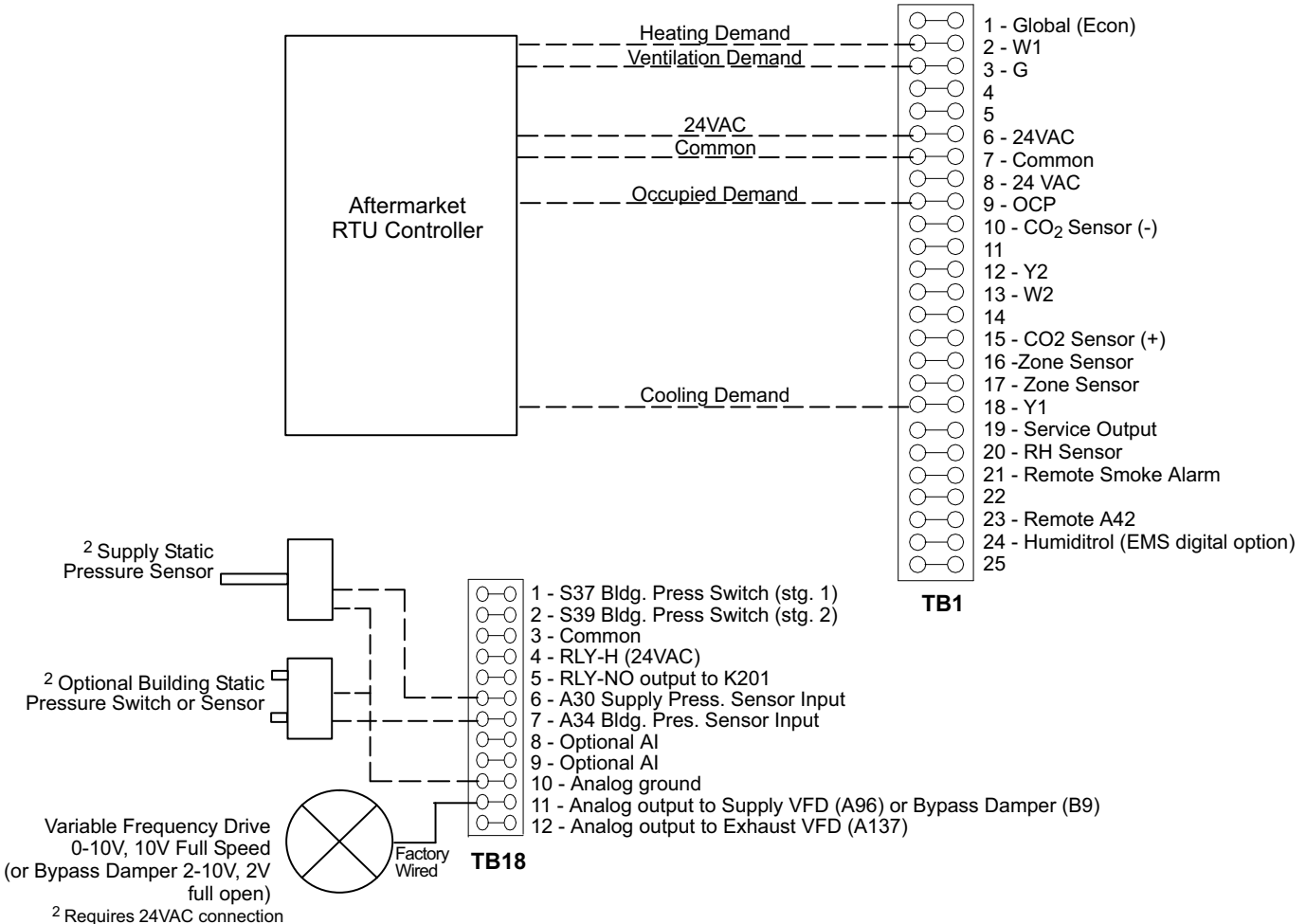

AFTERMARKET ZONING SYSTEM INTERFACE

Sequence of Operation **IMC Supervisory Control**

Operation when IMC blower (G) input is energized

When a G signal is present, the IMC controls the VFD or bypass damper to hold a constant supply duct static pressure based on the input from the IMC pressure sensor, using a PID control loop. For increased flexibility, the IMC has separate, adjustable static pressure setpoints for ventilation, cooling, heating and smoke alarms. These set points reside in the memory of the IMC, have factory default settings, and may be adjusted in the field prior to start-up.

Operation when IMC occupied (OCP) input is energized

When an OCP signal is present, the IMC adjusts the fresh air damper to either a fixed minimum position or allows it to modulate based on a CO₂ sensor. The CO₂ sensor can be wired directly to the IMC, to another controller that can monitor the sensor and pass a signal to the IMC for damper control, or to both the IMC and another device for monitoring through the desired man-machine interface while the IMC maintains damper control. During morning warm-up/cool-down the IMC keeps the fresh air damper closed based on the IMC configuration settings selected. The set points for minimum and maximum damper position setting and CO₂ control reside in the memory of the IMC, have factory default settings, and may be adjusted at start up. They cannot be adjusted using the aftermarket controls system.

Operation when IMC first stage cooling (Y1) input is energized

When a Y1 signal is present the IMC controls up to 4 stages of cooling (depending on RTU configuration) to maintain a cooling discharge air temperature setpoint. These stages include mechanical cooling, or outdoor air for cooling with an economizer. The discharge air temperature setpoint resides in the IMC, has a factory default setting, and may be adjusted at start up. It cannot be adjusted using the aftermarket controls system. The IMC has advanced discharge-air cooling reset options selected at start up based on return air temperature and/or outside air temperature. Outside air reset saves energy by gradually increasing the discharge air set point as outside air temperature decreases. Return air reset reduces potential for overcooling if the zoning system is misapplied, has an abnormal condition, or a dominant zone. The reset gradually increases discharge air temperature as return air temperature decreases.

NOTE - Y2 signal is recommended for constant volume applications.

Operation when IMC first stage heating (W1) input is energized

When a W1 signal is present, the IMC controls up to 4 stages of heating (depending on RTU configuration) to maintain a heating discharge air temperature. The heating discharge air temperature set point resides in the IMC, has a factory default setting, and may be adjusted at start up. It cannot be adjusted using the aftermarket controls system. The IMC has advanced discharge air heating reset options based on return air temperature and/or outside air temperature. Outside air reset saves energy by gradually decreasing the discharge air set point as outside air temperature increases. Return air reset reduces the potential for overheating if the zoning system is misapplied, has an abnormal condition, or a dominant zone. The reset gradually decreases discharge air temperature as return air temperature increases.

NOTE - W2 signal is recommended for constant volume applications.

Power Exhaust Fan Operation

The IMC has many power exhaust fan control options that include single-stage, two-stage and modulating control, depending on how the unit is equipped. Stage control options can be triggered based on fresh air damper positions, pressure switches, or a analog pressure sensor. Modulating control for units with VFD powered exhaust fans are typically modulated to maintain return or building static pressure, but can be staged. Set-points and operation settings for controlling power exhaust fans reside in the IMC, have factory default settings, and may be adjusted at start up. They cannot be adjusted using the aftermarket controls system.

REVISIONS

Sections	Description of Change
Options/Accessories	Removed Sectra
High Altitude Derate	Updated Maximum Input Rate data.
Electrical Data	All new data
Dimensions	New drawings for diffusers
Application Guide	Updated section to reflect usage with M1-6 and higher versions



VERIFIED
ENERGY
PERFORMANCE



VERIFIE
RENDEMENT
ENERGETIQUE



LENNOX®

Visit us at www.lennox.com
For the latest technical information, www.lennoxdavenet.com
Contact us at 1-800-4-LENNOX

NOTE - Due to Lennox' ongoing commitment to quality, Specifications, Ratings and Dimensions subject to change without notice and without incurring liability. Improper installation, adjustment, alteration, service or maintenance can cause property damage or personal injury. Installation and service must be performed by a qualified installer and servicing agency.

©2008 Lennox Industries Inc.