



LGH

**Energence® Rooftop Units
Ultra-Low NOx - 60 Hz**

**COMMERCIAL
PRODUCT SPECIFICATIONS**

Bulletin No. 210925
March 2021
Supersedes June 2020

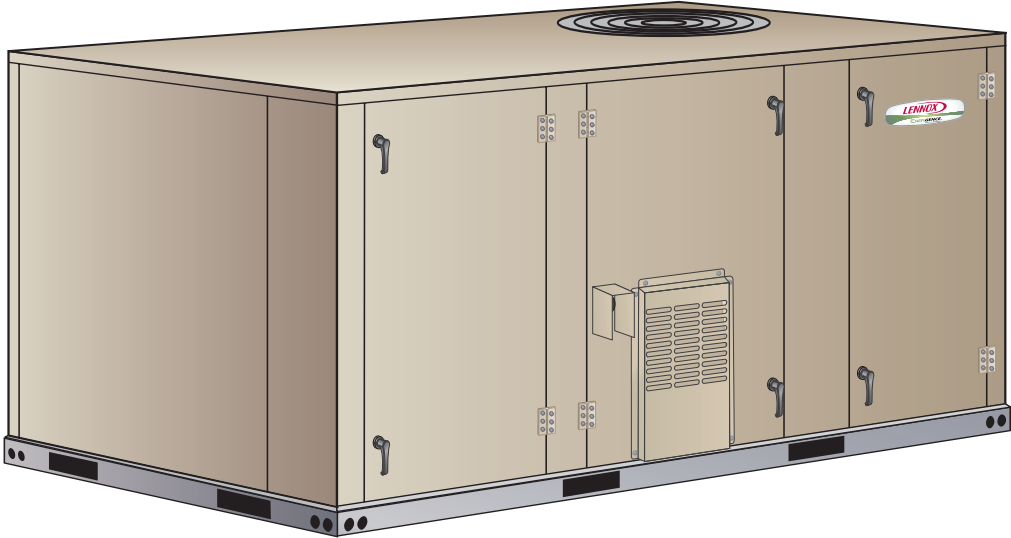

**3 to 5 Tons
Net Cooling Capacity - 34,800 to 60,000 Btuh
Gas Input Heat Capacity - 60,000 and 100,000 Btuh**

MODEL NUMBER IDENTIFICATION

LGH060H4EA1Y

Brand/Family
L = Energence®

Unit Type
G = Packaged Gas Heat w/ Electric Cooling

Major Design Sequence
H = 1st Generation

Nominal Cooling Capacity - Tons
036 = 3 Tons
048 = 4 Tons
060 = 5 Tons

Cooling Efficiency
H = High Efficiency

Refrigerant Type
4 = R-410A

Voltage
P = 208/230V-1 phase-60hz
Y = 208/230V-3 phase-60hz
G = 460V-3 phase-60hz

Minor Design Sequence
1 = 1st Revision

Heating Type
A = Standard Gas Heat, 2 Stage, Ultra Low NOx (14ng/J)
F = Medium Gas Heat, 2 Stage, Ultra Low NOx (14ng/J)

Blower Type
E = Direct Drive (ECM)

FEATURE HIGHLIGHTS

Lennox' Energence® packaged rooftop unit product line was created to save energy with intelligence by offering some of the highest energy efficiency ratings available with a powerful, easy to use unit controller. This makes Energence rooftop units perfect for business owners looking for an HVAC product with the lowest total cost of ownership.

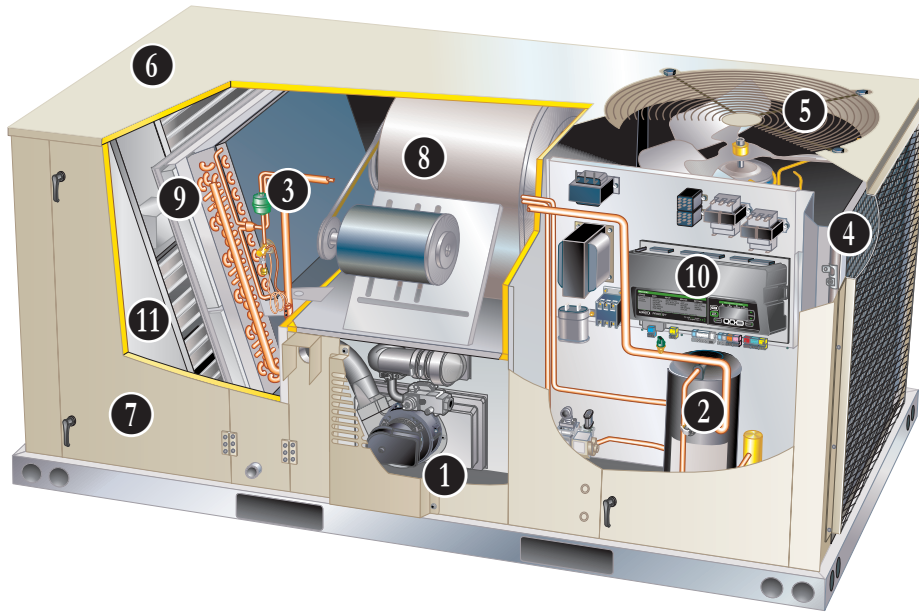

1. Heat Exchanger Assembly
2. Two Stage Compressor
3. Filter/Drier
4. Lennox' Environ™ Coil System
5. Variable Speed Outdoor Coil Fan Motor
6. Heavy Gauge Steel Cabinet
7. Hinged Access Panels
8. Supply Air Blower (ECM Motor)
9. Air Filters
10. Prodigy 2.0 Control System
11. Economizer (option)

NOTE - ULTRA-LOW NOX MODEL ARE NATURAL GAS ONLY!
NOTE - NOT AVAILABLE IN ALL AREAS!
CONTACT YOUR NEAREST LENNOX SALES OFFICE FOR DETAILS.

CONTENTS

Approvals And Warranty	3
Blower Data	24
Cooling Ratings	21
Dimensions - Accessories	33
Dimensions - Unit	32
Electrical Data	28
Features And Benefits	3
High Altitude Operation.	20
Humiditrol® Dehumidification System Option	11
Humiditrol® Dehumidification System Ratings.	23
Model Number Identification.	1
Optional Conventional Temperature Control Systems	12
Options / Accessories	16
Outdoor Sound Data	30
Sequence Of Operation.	15
Specifications	19
Specifications - Gas Heat	20
Unit Clearances	31
Weight Data	30

APPROVALS AND WARRANTY

APPROVALS

- AHRI Certified to AHRI Standard 210/240
- ETL and CSA listed
- Efficiency rating certified by CSA
- Approved by the California Energy Commission and meets California Nitrogen Oxides Standard (NOx) limits of 14 ng/J
- Components bonded for grounding to meet safety standards for servicing required by UL, ULC, and National and Canadian Electrical Codes
- All models are ASHRAE 90.1 compliant
- ENERGY STAR® certified units are designed to use less energy, help save money on utility bills, and help protect the environment
- ISO 9001 Registered Manufacturing Quality System

WARRANTY

- Heat exchanger - Limited ten years
- Compressors - Limited five years
- Lennox' Environ™ Coil System - Limited three years
- Prodigy 2.0 Unit Controller - Limited three years
- Optional High Performance Economizers - Limited five years
- All other covered components - Limited one year

FEATURES AND BENEFITS

HEATING SYSTEM

1 Heat Exchanger Assembly

- Heavy gauge stainless steel heat exchanger with single premix stainless steel burner
- Tubular type design
- Designed for normal expansion and contraction with maximum efficiency and minimum resistance to air flow
- Laboratory life cycle tested in excess of industry standards
- Compact size permits low overall design of furnace cabinet

Direct Spark Ignition

- Provides positive and safe main burner ignition
- Spark is intermittent and occurs only when required

Limit Controls

- Redundant limit controls
- Fixed temperature setting
- Protects heat exchanger and other components from overheating

Modulating Gas Control Valve

- 24 volt redundant combination modulating gas control valve combines manual shut off switch (On-Off), automatic electric valve (dual) and gas pressure regulation into a compact combination control

Variable-Speed Combustion Air Inducer

- Heavy duty blower prepurges heat exchanger and safely vents flue products
- ECM variable speed motor
- Proves blower operation before allowing gas valve to open
- Operates only during heating cycle

Safety Switches

- Flame roll-out switch, flame sensor and combustion air inducer proving switch protect system operation
- All safety switches are monitored by the Prodigy 2.0 Unit Controller and diagnostic information is reported and recorded

Required Selections

Gas Input Choice - Order one:

- Standard Gas Heat (2 Stage)
45,000 / 60,000 Btuh
- Medium Gas Heat (2 Stage)
75,000 / 100,000 Btuh

FEATURES AND BENEFITS

COOLING SYSTEM

- Designed to maximize sensible and latent cooling performance at design conditions
- System operation from 0°F to 125°F without additional controls

R-410A Refrigerant

- Non-chlorine based
- Ozone friendly

2 Two-Stage Scroll Compressor

- Scroll compressor on all models for high performance, reliability and quiet operation
- Resiliently mounted on rubber grommets for quiet operation

Compressor Crankcase Heater

- Protects against refrigerant migration that can occur during low ambient operation or during extended off cycles

Thermal Expansion Valve

- Ensures optimal performance throughout the application range
- Removable element head

3 Filter/Drier

- High capacity filter/drier protects the system from dirt and moisture

High Pressure Switch

- Protects the compressor from overload conditions such as dirty condenser coils, blocked refrigerant flow, or loss of outdoor fan operation

Low Pressure Switch

- Protects the compressor from low pressure conditions such as low refrigerant charge, or low/no airflow

Freezestat

- Protects the evaporator coil from damaging ice build-up due to conditions such as low/no airflow, or low refrigerant charge

4 Condenser Coil - Lennox' Environ™ Coil System

- Condenser coil features lightweight, all aluminum brazed fin construction
- Constructed of three components:
 - A flat extrusion tube
 - Fins in-between the flat extrusion tube
 - Two refrigerant manifolds

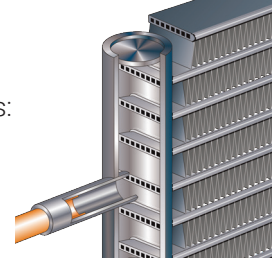

Environ™ Coil System Features:

- Improved heat transfer performance due to high primary surface area (flat tubes) versus secondary surface (fins)
- Smaller internal volume (reduced refrigerant charge)
- High durability
- Fewer brazed joints
- Compact design
- Easy maintenance/cleaning
- Face-split design
- Mounting brackets with rubber inserts secure coil to unit providing vibration dampening and corrosion protection

Evaporator Coil

- Copper tube construction
- Enhanced rippled-edge aluminum fins
- Flared shoulder tubing connections
- Silver soldered construction
- Factory leak tested
- Cross row circuiting with rifled tubing

Condensate Drain Pan

- Plastic pan, sloped to meet drainage requirements of ASHRAE 62.1
- Side or bottom drain connections
- Reversible to allow connection at back of unit

5 Variable Speed Outdoor Coil Fan Motor

- Variable speed (ECM) fan motor for energy efficient MSAV® (Multi-Stage Air Volume) operation and quiet operation
- Thermal overload protected
- Totally enclosed
- Permanently lubricated ball bearings
- Shaft up
- Wire basket mount

Outdoor Coil Fan

- PVC coated fan guard furnished

Required Selections

Cooling Capacity

- Specify nominal cooling capacity

FEATURES AND BENEFITS

COOLING SYSTEM (continued)

Options/Accessories

Factory or Field Installed

Condensate Drain Trap

- Available in copper or PVC

NOTE - Factory installed option is shipped with the unit for field installation.

Drain Pan Overflow Switch

- Monitors condensate level in drain pan
- Shuts down unit if drain becomes clogged

CABINET

6 Construction

- Heavy-gauge steel panels
- Full perimeter heavy-gauge galvanized steel base rail
- Base rails have rigging holes
- Three sides of the base rail have forklift slots
- Raised edges around duct and power entry openings in the bottom of the unit for water protection

Airflow Choice

- Units are shipped in downflow (vertical) return air flow configuration

NOTE - Units can be field converted to horizontal airflow with optional Horizontal Discharge Kit.

Duct Flanges

- Provided for horizontal duct attachment

Power/Gas Entry

- Electrical and gas lines can be brought through the unit base or through horizontal access knock-outs

Exterior Panels

- Constructed of heavy-gauge, galvanized steel
- Two-layer enamel paint finish

Insulation

- Fully insulated with non-hygroscopic fiberglass insulation (conditioned areas)
- Unit base is fully insulated
- Base insulation serves as an air seal to the roof curb, eliminating the need to add a seal during installation

7 Hinged Access Panels

- Tool-less access
- Economizer/ Filter sections
- Compressor/controls sections
- Panel seals and quarter-turn latching handles provide a tight air and water seal

NOTE - Optional Economizers, Power Exhaust, Outdoor Air Dampers and Barometric Relief Dampers for 060 models include a filler panel for proper cabinet fit.

Required Selections

Airflow Configuration

- Specify horizontal or downflow

Options/Accessories

Factory Installed

Corrosion Protection

- Completely flexible immersed coating
- Electrodeposited dry film process
- AST ElectroFin E-Coat
- Meets Mil Spec MIL-P-53084, ASTM B117 Standard Method Salt Spray Testing
- Indoor Corrosion Protection:
 - Coated coil
 - Coated reheat coil (Humiditrol®)
 - Painted blower housing
 - Painted base
- Outdoor Corrosion Protection:
 - Coated coil
 - Painted outdoor base

Field Installed

Combination Coil/Hail Guards

- Heavy gauge steel frame
- Painted to match cabinet
- Expanded metal mesh protects outdoor coil

FEATURES AND BENEFITS

BLOWER

Motor

- Variable-speed ECM direct drive motor
- Overload protected, equipped with ball bearings

8 Supply Air Blower

- Forward curved blades
- Double inlet
- Blower wheel statically and dynamically balanced
- Ball bearings
- Blower assembly slides out of unit for servicing

ELECTRICAL

SmartWire™ System

- Keyed and color-coded wiring connectors prevent miswiring
- Wire coloring scheme is standardized across all models
- Each connection is intuitively labeled to make troubleshooting and servicing quick and easy

Electrical Plugs

- Positive connection electrical plugs are used to connect common accessories or maintenance parts for easy removal or installation

Required Selections

Voltage Choice

- Specify when ordering base unit

Options/Accessories

Factory Installed

Circuit Breakers

- HACR type
- For overload and short circuit protection
- Factory wired and mounted in the power entry panel
- Current sensitive and temperature activated
- Manual reset

Phase/Voltage Detection

(3 Phase models only)

- Monitors power supply to assure phase is correct at unit start-up
- If phase is incorrect, the unit will not start and an alarm code is reported to the unit controller
- Protects unit from being started with incorrect phasing which could lead to issues such as compressors running backwards
- Voltage detection monitors power supply voltage to assure proper voltage
- If voltage is not correct (over/under voltage conditions) the unit will not start and an alarm code is reported to the unit controller

Short-Circuit Current Rating (SCCR)

- Higher short circuit protection up to 100kA

NOTE - Disconnect Switch is not available as an option with High SCCR option.

Factory or Field Installed

Disconnect Switch

- Accessible outside of unit
- Spring loaded weatherproof cover furnished

GFI Service Outlets (2)

- 115V ground fault circuit interrupter (GFCI) type
- Non-powered
- Field-wired

INDOOR AIR QUALITY

9 Air Filters

- Disposable 2 inch filters furnished as standard

Options/Accessories

Factory or Field Installed

Healthy Climate® High Efficiency Air Filters

- Disposable MERV 8 or MERV 13 (Minimum Efficiency Reporting Value based on ASHRAE 52.2) efficiency 2-inch pleated filters

Field Installed

Healthy Climate® UVC Germicidal Lamps



- Germicidal lamps emit ultra-violet (UV-C) energy, which has been proven to be effective in reducing microbes such as viruses, bacteria, yeasts, and molds
- This process either destroys the organism or controls its ability to reproduce
- UV-C energy greatly reduces the growth and proliferation of mold and other bioaerosols (bacteria and viruses) on illuminated surfaces (particularly coil and drain pan)
- Field installed in the blower/evaporator coil section
- Magnetic safety interlock terminates power when access panels are removed
- All necessary hardware for installation is included
- Lamps operate on 110/230V, 1 phase power supply

NOTE - Step-down transformer may be ordered separately for 460V units.

- Approved by ETL

Indoor Air Quality (CO₂) Sensors

- Monitors CO₂ levels
- Reports to the Prodigy 2.0 Unit Controller, which adjusts economizer dampers as needed

Replacement Filter Media Kit With Frame

- Replaces existing pleated filter media
- Includes washable metal mesh screen and metal frame with clip for holding replaceable non-pleated filter

CONTROL SYSTEM

PRODIGY 2.0 CONTROL SYSTEM



10 The Prodigy 2.0 unit controller is a microprocessor-based controller that provides flexible control of all unit functions.

Features:

- LCD Display
- Easy to read menu (4 lines x 20 character display)
- Buttons for menu navigation during setup and diagnostic
- Menu navigation LEDs for Data, Setup, Service, Settings
- Main Menu and Help Buttons for quick navigation to home screen and built-in help functions
- Scroll, Value Adjustment Select and Save Buttons
- Setup menu insures proper installation and simplified setup of the rooftop unit
- Profile setup copies key settings between units with the same configuration to reduce setup time
- USB port allows a technician to download and transfer unit information to help verify service was performed
- USB software updates on the Prodigy® Control System enhance functionality without the need to change components
- Unit Controller Software
- Unit self-test verifies individual critical component and system performance
- Economizer test function assures economizer is operating correctly
- Time Clock with Run-Time Information

Built-In Functions Include:

- Adjustable Blower On/Off Delay
- Built-in Control Parameter Defaults
- Compressor Time-Off Delay
- DDC Compatible
- Dirty Filter Switch Input
- Discharge Air Temperature Control
- Display/Sensor Readout
- Economizer Control Options (See Economizer / Exhaust Air / Outdoor Air sections)
- Fresh Air Tempering
- Over 100 diagnostic and status messages in English
- Exhaust Fan Control Modes for fresh air damper position
- Permanent Diagnostic Code Storage
- Field Adjustable Control Parameters (Over 200 settings)
- Indoor Air Quality Input (Demand Control Ventilation)
- Low Ambient Controls for cooling operation down to 0°F

- Gas Valve Time Delay Between First and Second Stage
- Minimum Compressor Run Time
- Network Capable
(Can be daisy chained to other units or controls)
- Night Setback Mode
- Return Air Temperature Limit Control
- Safety Switch Input allows Controller to respond to a external safety switch trip
- Service Relay Output
- Smoke Alarm Mode has four choices
(unit off, positive pressure, negative pressure, purge)
- Up to 2 heat/2 cool
(standard Prodigy® unit controller thermostat input)
- Up to 3 cool with additional relay
- Up to 4 cool with room sensor or network operation
- “Strike Three” Protection
- Gas Reheat Control allows simultaneous heating and cooling operation for humidity control of process air applications such as supermarkets
- On Demand Dehumidification monitors and controls condenser hot gas reheat operation with Humiditrol® dehumidification option
- Thermostat Bounce Delay
- Warm Up Mode Delay
- LED Indicators
- PC Interface connects the Prodigy 2.0 unit controller to a PC with the Lennox Unit Controller Software
- Room Sensor Operation controls temperature

NOTE - Prodigy® Control System features vary with the type of rooftop unit in which the control is installed.

NOTE - See separate Prodigy® Control System Product Specifications Bulletin for additional information.

Controls Options

Factory Installed

SmartAirflow® System (Available for Three-Phase Models with Economizer)

- Complete airflow management system that precisely controls the economizer damper for accurate ventilation
- Allows the installer to directly enter the design-specified supply air (blower) and outdoor air volume (economizer minimum position) parameters without the need to manually take measurements and adjust settings
- Monitors supply air volume and outside air volume as well as customizable diagnostics

NOTE - SmartAirflow® is not available for single phase models.

CONTROL SYSTEM

PRODIGY 2.0 CONTROL SYSTEM (continued)

Options/Accessories

Factory or Field Installed

Blower Proving Switch

- Monitors blower operation
- Shuts down unit if blower stops

Dirty Filter Switch

- Senses static pressure increase

Fresh Air Tempering

- Used in applications with high outside air requirements
- Controller energizes the first stage heat as needed to maintain a minimum supply air temperature for comfort, regardless of the thermostat demand
- When ordered as a factory option, sensor ships with the unit for field installation

Smoke Detector

- Photoelectric type
- Installed in supply air section, return air section or both sections
- Available with power board and single sensor (supply or return) or power board and two sensors (supply and return)
- Power board located in unit control compartment

Interoperability via BACnet® or LonTalk® Protocols

- Communication compatible with third-party automation systems that support the BACnet Application Specific Controller device profile, LonMark® Space Comfort Controller functional profile, or LonMark Discharge Air Controller functional profile

Commercial Control Systems

L Connection® Network Control System

- Complete building automation control system for single or multi-zone applications
- Options include local interface, software for local or remote communication, and hardware for networking other control functions
- See L Connection Network Control System Product Specifications Bulletin for details

After-Market DDC

- Novar® Unit Controller and options

Thermostats

- Control system and thermostat options
- After-Market unit controller options

Field Installed

General Purpose Control Kit

- Plug-in control provides additional analog and digital inputs/outputs for field installed options

Humidity Sensor Kit

- Humidity sensor required with factory installed Humiditrol® Dehumidification Option or Supermarket reheat field selectable option

OPTIONS / ACCESSORIES

ECONOMIZER

- 11 • Economizer operation is set and controlled by the Prodigy 2.0 Unit Controller
- Simple plug-in connections from economizer to unit controller for easy installation
- All Emergence® rooftop units are equipped with factory installed CEC Title 24 approved sensors for outside, return and discharge air temperature monitoring

NOTE - Optional sensors may be used instead of unit sensors to determine whether outdoor air is suitable for free cooling. See Options/Accessories table.

Factory or Field Installed

High Performance Economizer

- Approved for California Title 24 building standards
- Low leakage dampers are Air Movement and Control Association International (AMCA) Class 1A Certified - Maximum 3 CFM per sq. ft. leakage at 1 in. w.g.
- ASHRAE 90.1 compliant
- Combination Outdoor Air Hood is furnished
- Factory installed Economizer can be ordered with three exhaust options:
 - Barometric Relief Dampers
 - Power Exhaust Fan

NOTE - See Power Exhaust Fan section for additional requirements.

- No Exhaust
- Field installed Economizer includes Barometric Relief Dampers with Combination Hood
- Barometric Relief Dampers allow relief of excess air
- Dampers prevent blow back and outdoor air infiltration during off cycle
- Bird screen furnished

NOTE - Barometric Relief Dampers are required when Economizer is factory installed with factory installed Power Exhaust Fan option. See Power Exhaust Fan section and Options/Accessories table.

- Demand Control Ventilation (DCV) ready using optional CO₂ sensors.
- Horizontal Barometric Dampers are required for horizontal Economizer applications and must be ordered separately.
- Gear-driven action
- High torque 24-volt
- Fully-modulating spring return damper motor
- Return air and outdoor air dampers
- Plug-in connections to unit
- Nylon bearings
- Enhanced thermoplastic vulcanizate (TPV) seals
- Flexible stainless steel jamb seals to minimize air leakage

OPTIONS / ACCESSORIES

ECONOMIZER (continued)

Factory or Field Installed (continued)

NOTE - High Performance Economizers are not approved for use with enthalpy controls in Title 24 applications.

NOTE - The Free Cooling setpoint for Title 24 applications must be set based on the Climate Zone where the system is installed. See Section 140.4 "Prescriptive Requirements for Space Conditioning Systems" of the California Energy Commission's 2013 Building Energy Efficiency Standards.

NOTE - Refer to Installation Instructions for complete setup information.

Differential Sensible Control

- Factory setting
- Uses outdoor air and return air sensors that are furnished with the unit
- The Prodigy 2.0 unit controller compares outdoor air and return air and using setpoints
- Engages the economizer when the outdoor air temperature is below the configured setpoint and cooler than return air

NOTE - Differential Sensible Control can be configured in the field to provide Offset Differential Sensible Control or Single Sensible Control.

- In Offset Differential Sensible Control mode, the economizer is enabled if the temperature differential (offset) between outdoor air and return air reaches the configured setpoint
- In Single Sensible Control mode, the economizer is enabled when outdoor air temperature falls below the configured setpoint

Global Control

- The unit controller communicates with a DDC system with one global sensor (enthalpy or sensible) to determine whether outside air is suitable for free cooling on all units connected to the control system. Sensor must be field provided.

NOTE - Global control with enthalpy is not approved for Title 24 applications.

Single Enthalpy Temperature Control (Not for Title 24)

- Outdoor air enthalpy sensor enables Economizer if the outdoor enthalpy is less than the setpoint of the control.

Differential Enthalpy Control (Not for Title 24)

- Order two Single Enthalpy Controls.
 - One is field installed in the return air section
 - One in the outdoor air section
- Allows the economizer control to select between outdoor air or return air, whichever has lower enthalpy

Field Installed

Building Pressure Control

- Maintains constant building pressure level
- Using differential pressure information between the outdoor air and the building air, the Prodigy 2.0 unit controller changes the economizer position to help maintain a constant building pressure

NOTE - Not available with Demand Control Ventilation (CO₂ Sensor).

Horizontal Barometric Relief Dampers

- For use when unit is configured for horizontal applications with an economizer
- Allows relief of excess air
- Blade type dampers prevent blow back and outdoor air infiltration during off cycle
- Field installed in return air duct
- Exhaust hood with bird screen furnished
- Requires Horizontal Economizer Conversion Kit

Horizontal Economizer Conversion Kit

- Insulated panel covers the bottom return air opening on the unit base to convert downflow economizer to horizontal air flow

OPTIONS / ACCESSORIES

EXHAUST

Factory or Field Installed

Power Exhaust Fan

- Installs internal to unit for downflow applications only with economizer option
- Provides exhaust air pressure relief
- Interlocked to run when supply air blower is operating
- Fan runs when outdoor air dampers are 50% open (adjustable)
- Motor is overload protected
- Fan is 16 in. diameter
- Four blades
- One 1/3 hp motor

NOTE - If Power Exhaust is field installed with a factory installed Economizer, the Economizer must be ordered with No Exhaust option. Barometric Relief Dampers must also be ordered separately for field installation.

NOTE - If Power Exhaust is factory installed with a factory installed Economizer, Barometric Relief Dampers must also be ordered separately for field installation.

OUTDOOR AIR

Factory or Field Installed

Outdoor Air Damper

- Downflow or Horizontal
- Linked mechanical dampers
- 0 to 25% (fixed) outdoor air adjustable
- Installs in unit
- Includes outdoor air hood
- Automatic model features fully modulating spring return damper motor with plug-in connection
- Manual model features parallel blade, gear-driven dampers with adjustable fixed position

ROOF CURBS

Field Installed

- Nailer strip furnished (downflow only)
- Mates to unit
- US National Roofing Contractors Approved
- Shipped knocked down

Hybrid Roof Curbs, Downflow

- Interlocking tabs fasten corners together
- No tools required
- Can also be fastened together with furnished hardware
- Available in 8, 14, 18, and 24 inch heights

Adjustable Pitch Curb

- Fully adjustable pitch curbs (3/4 in. per foot in any direction) provide a level platform for rooftop units allowing flexible installations on roofs with uneven or sloped angles
- Uses interlocking tabs to fasten corners together. No tools required
- Hardware is furnished to connect upper curb with lower curb
- Available in 14 inch height

Adaptor Curbs (not shown)

- Curbs are regionally sourced
- Dimensions vary based upon the source

NOTE - Contact your local sales representative for a detailed cut sheet with applicable dimensions.

CEILING DIFFUSERS

Field Installed

Ceiling Diffusers (Flush or Step-Down)

- White powder coat finish on diffuser face and grilles
- Insulated UL listed duct liner
- Diffuser box has collars for duct connection
- Step-down diffusers have double deflection blades
- Flush diffusers have fixed blades
- Provisions for suspending
- Internally sealed to prevent recirculation
- Removable return air grille
- Adapts to T-bar ceiling grids or plaster ceilings

Transitions (Supply and Return)

- Used with diffusers
- Installs in roof curb
- Galvanized steel construction
- Flanges furnished for duct connection to diffusers
- Fully insulated

HUMIDITROL® DEHUMIDIFICATION SYSTEM OPTION

OVERVIEW

- Factory installed option designed to control humidity
- Provides dehumidification on demand using ASHRAE 90.1 recommended method for comfort conditioning humidity control
- Unit comes equipped with one row reheat coil, solenoid valve and humidity controller
- A thermostat with a dehumidification output, a dehumidistat, or a DDC controller with an isolated output is required to control humidity and must be located in the occupied space

BENEFITS

- Improves indoor air quality
- Helps prevent damage due to high humidity levels
- Improves comfort levels by reducing space humidity levels

OPERATION

No Dehumidification Demand

- The unit will operate conventionally whenever there is a demand for cooling or heating and no dehumidification demand
- Free cooling is only permitted when there is no demand for dehumidification

Dehumidification Demand Only

- The Unit Controller is factory set at 60% relative humidity setpoint and can be adjusted at the Unit Controller or with optional Unit Controller Software
- For L Connection® Network Control Panel (NCP) applications, the humidity setpoint can be adjusted at the NCP
- Reheat operation will initiate on a dehumidification demand and does not require a cooling demand
- The unit will operate in the dehumidification mode until the relative humidity of the conditioned space is below the setpoint
- The reheat coil is sized to provide 68°F to 75°F supply air during reheat operation
- This reduces sensible cooling capacity and extends compressor run time to control humidity when the cooling load is low
- A solenoid valve diverts hot gas from the compressor to the reheat coil

- The cooled and dehumidified air from the evaporator is reheated as it passes through the reheat coil
- The de-superheated and partially condensed refrigerant continues to the outdoor condenser coil where condensing is completed
- Unit will continue to operate in this mode until the dehumidification demand is satisfied

NOTE - See Sequence of Operation for additional information.

Dehumidification and Cooling Demand (Thermostat/Room Sensor Application)

- If both a dehumidification and a 1st stage cooling demand occur, the system will operate in the full cooling mode at first stage indoor air flow. If a 2nd stage cooling demand occurs along with a dehumidification demand, the system operates in full cooling mode at full cooling airflow until the 2nd stage cooling demand is satisfied
- Then the system will revert to the dehumidification mode if a dehumidification mode demand is present

Options/Accessories

Humidity Sensor Kit

- Remote mounted dehumidistat for factory installed Humiditrol® option or Supermarket reheat field selectable option

NOTE - A thermostat with a dehumidification output or a DDC controller with an isolated output can be used instead.

TYPICAL DEHUMIDIFICATION SCHEMATIC

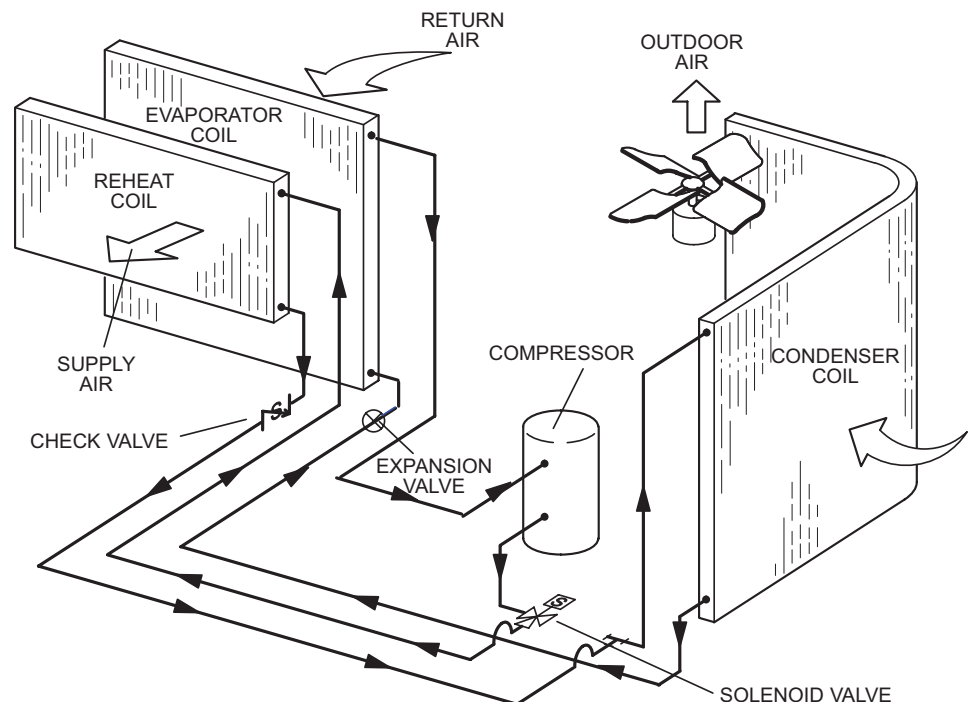

OPTIONAL CONVENTIONAL TEMPERATURE CONTROL SYSTEMS

ComfortSense® 8500 Commercial 7-Day Programmable Thermostat

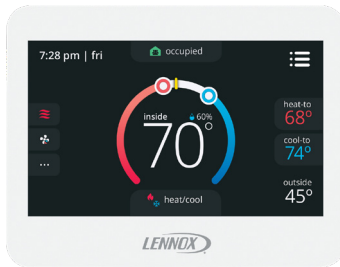

- Fully Communicating Sensor
- Full Color Touchscreen Interface
- Variable Speed System Control (On Compatible Units)
- Up To 4 Heat / 4 Cool
- Built-In Sensors For Temperature, Humidity And Optional CO₂
- Remote Sensor Options For Occupancy, Temperature
- BACnet Capable Options
- 5-2 or 7-Day Scheduling
- Smooth Setback Recovery
- Heat/Cool Auto-Changeover
- Four-Wire Installation
- FDD, ASHRAE, IECC Compliant

ComfortSense® 7500 Commercial 7-Day Programmable Thermostat



- Premium Universal Thermostat
- Full Color Touchscreen Interface
- Up To 4 Heat / 4 Cool
- Built-In Sensors For Temperature and Humidity
- Remote Sensors Options For Temperature, Discharge Air, Outdoor Air
- 5-2 or 7-Day Scheduling
- Smooth Setback Recovery
- Heat/Cool Auto-Changeover
- FDD, ASHRAE, IECC Compliant

ComfortSense® 3000 Commercial 5-2 Day Programmable Thermostat

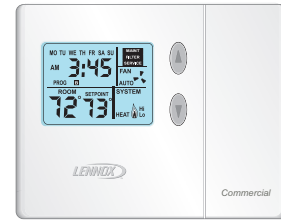

- Conventional Multi-Stage Thermostat
- Intuitive Display
- Push-Button Operation
- Up To 2 Heat / 2 Cool
- Built-In Temperature Sensor
- Remote Temperature Sensing
- Up to 5-2 Day Scheduling
- Smooth Setback Recovery
- Heat/Cool Auto-changeover

Wired Room Sensor (LCS-5030)



- Simple Push-Button Override
- Variable Speed System Control (On Compatible Units)
- Up To 4 Heat / 4 Cool
- Built-In Temperature and Humidity Sensors
- AA Battery / 24VAC Powered
- SBUS Wired Operation
- Automatic Sensor Averaging
- Locking Hex Screw

OPTIONAL CONVENTIONAL TEMPERATURE CONTROL SYSTEMS

Description	Catalog No.
ComfortSense® 8500 Commercial 7 Day Programmable Thermostat	
CS8500 7-Day Thermostat	No CO ₂ Sensing 17G75
	With CO ₂ Sensing 17G76
Sensors/Accessories	¹ Remote non-adjustable wall-mount 10k 47W37
	¹ Remote non-adjustable wall-mount 11k 94L61
Sysbus Network Cable (Yellow) for ComfortSense 8500 and LCS-5030 Wired Room Sensor	
Twisted pair 100% shielded communication cable, Red and Black	500 ft. box 27M19
22 AWG, yellow jacket, rated at 75°C, 300V, Plenum rated	1000 ft. box 94L63
Insulation - Low smoke PVC, NEC, CMP	2500 ft. roll 68M25
ComfortSense® 7500 Commercial 7-Day Programmable Thermostat	
CS7500 7-Day Thermostat	17G74
Sensors/Accessories	² Remote non-adjustable wall-mount 20k 47W36
	² Remote non-adjustable wall-mount 10k 47W37
	Remote non-adjustable discharge air (duct mount) 19L22
	Outdoor temperature sensor X2658
ComfortSense® 3000 Commercial 5-2 Day Programmable Thermostat	
CS3000 5-2 Day Thermostat	11Y05
Sensors/Accessories	Remote non-adjustable wall mount 10k averaging 47W37
	Thermostat wall mounting plate X2659
ComfortSense® Non-Programmable Thermostat	
CS3000 Non-Programmable Thermostat	51M32
Universal Thermostat Guard with Lock (clear)	
	Inside Dimensions (H x W) 5 7/8 x 8 3/8 in. 39P21
Wired Room Sensor	
LCS-5030 Wired Room Sensor	21L07

¹ Up to nine of the same type remote temperature sensors can be connected in parallel.

² Remote wall-mount sensors can be applied in any of the following combinations:
 One Sensor - (1) 47W36, Two Sensors - (2) 47W37, Three Sensors - (2) 47W36 and (1) 47W37
 Four Sensors - (4) 47W36, Five Sensors - (3) 47W36 and (2) 47W37

SEQUENCE OF OPERATION

Objective: Outline the unit functions as a result of room thermostat or zone sensor demands.

Given: When economizer is present, it will function as initial part of the unit cooling system. When not present, unit will function as if outdoor ambient is high and sensed as not suitable.

DIRECT DRIVE OPERATION:

NOTE: Direct drive units feature ECM condenser fans that are staged to match the compressor's capacity. When the compressor is operating at first stage, the condenser fan is operating at low speed. The condenser fan switches to high speed when the compressor switches to second stage to match operation.

Modulating Outdoor Air Damper:

Damper minimum positions #1 and 2 are adjusted during unit setup to provide minimum fresh air requirements at the indicated supply fan speeds per ASHRAE 62.1.

- Supply fan is off and the outdoor air damper is closed
- Supply fan is on low speed and the outdoor air damper is at minimum position 1
- Supply fan is on high speed and the outdoor air damper is at minimum position 2

¹ Unit Features an Economizer and Outdoor Air is Suitable

Cooling - Thermostat or Zone Sensor Mode (Up to 3 stages Y1, Y2, Y3)

Y1 Demand:

Compressor is off, supply fan is on low speed, economizer modulates (minimum to maximum open position) to maintain 55°F supply air temperature (default unit controller setting)

After 5 minutes (default unit controller setting), supply fan switches to high speed. Economizer continues modulating with supply fan on high speed to maintain 55°F supply air temperature

Y2 Demand:

Compressor is off, supply fan is on high speed, and economizer modulates to maintain 55°F supply air temperature

Economizer opens to maximum. If economizer stays at maximum open for 3 minutes (default unit controller setting) compressor is energized and operates at first stage while supply fan stays on high speed

¹ Outdoor air suitability is determined by the energy state of outdoor ambient (enthalpy or sensible) and its ability to achieve the desired free cooling effects. Outdoor air suitability can also be determined by a third party controller and provided to the RTU via a network connection.

Y3 Demand:

Economizer is at maximum open and compressor operates at first stage. If economizer stays at maximum open for 3 minutes (default unit controller setting) compressor switches to second stage operation while supply fan stays on high speed

Unit Does Not Feature an Economizer (or Outdoor Air Is Not Suitable)

Cooling - Thermostat or Zone Sensor (Up to 2 stages Y1, Y2)

Y1 Demand:

Compressor operates at first stage and supply fan operates at low speed

Y2 Demand:

Compressor operates at second stage and supply fan operates at high speed

(Continued on Next Page)

SEQUENCE OF OPERATION

DIRECT DRIVE OPERATION

(Continued):

Dehumidification Mode (economizer free cooling is locked out):

Unit features the Humiditrol® Dehumidification option

No Y1, Y2 Demand but a call for dehumidification:

Compressor operates at second stage, supply fan operates at low speed, and the reheat valve is energized

Y1 Demand:

Compressor operates at second stage, outdoor fan operates at high speed, supply fan operates at low speed and the reheat valve is de-energized

Y2 Demand:

Compressor operates at second stage, supply fan operates at high speed, and the reheat valve is de-energized

Heating Mode: Thermostat or Zone Sensor (Up to 2 stages W1, W2)

W1 Demand:

Gas valve is open (stage 1 on units with 2 stage gas valve) and the supply fan operates at high speed

W2 Demand:

Gas valve is open (stage 2 on units with 2 stage gas valve) and the supply fan operates at high speed

OPTIONS / ACCESSORIES

Item	Catalog Number	Unit Model Number			
		036	048	060	
COOLING SYSTEM					
Condensate Drain Trap	PVC	22H54	OX	OX	OX
	Copper	76W27	OX	OX	OX
Conventional Fin/Tube Condenser Coil (replaces Environ™ Coil System)	Factory		O	O	O
Drain Pan Overflow Switch	21Z07		OX	OX	OX
Efficiency	Standard	Factory	O	O	O
	High	Factory	O	O	O
HEATING SYSTEM					
Gas Heat Input	Standard Two-Stage - 45/60 kBtuh Input	Factory	O	O	O
	Medium Two-Stage - 75/100 kBtuh Input	Factory	O	O	O
BLOWER - SUPPLY AIR					
ECM Direct Drive, MSAV® (Multi-Stage Air Volume)	Direct Drive - 0.50 hp	Factory	O		
	Direct Drive - 0.75 hp	Factory		O	
	Direct Drive - 1 hp	Factory			O
CABINET					
Combination Coil/Hail Guards	13R98		X	X	
	13T03				X
Corrosion Protection (indoor coil / outdoor coil)	Factory		O	O	O
CONTROLS					
Blower Proving Switch	21Z10		OX	OX	OX
Commercial Controls	CPC Einstein Integration	Factory	O	O	O
	Prodigy® Control System - BACnet® Module	59W51	OX	OX	OX
	Prodigy® Control System - LonTalk® Module	54W27	OX	OX	OX
	Novar® LSE	Factory	O	O	O
	L Connection® Building Automation System	- - -	X	X	X
Dirty Filter Switch	53W66		OX	OX	OX
General Purpose Control Kit	13J78		X	X	X
Fresh Air Tempering	21Z08		OX	OX	OX
¹ SmartAirflow™ (Supply and Ventilation Airflow Control)	Factory		O	O	O
Smoke Detector - Supply or Return (Power board and one sensor)	21Z11		OX	OX	OX
Smoke Detector - Supply and Return (Power board and two sensors)	21Z12		OX	OX	OX

¹ Available for three-phase models with Economizer.

NOTE - Smart Airflow® is not available for single phase models.

NOTE - Catalog numbers shown are for ordering field installed accessories.

OX - Configure To Order (Factory Installed) or Field Installed

O = Configure To Order (Factory Installed)

X = Field Installed

OPTIONS / ACCESSORIES

Item	Catalog Number	Unit Model Number			
		036	048	060	
ELECTRICAL					
Voltage 60 hz	208/230V - 1 phase	Factory	² O	² O	² O
	208/230V - 3 phase	Factory	O	O	O
	460V - 3 phase	Factory	O	O	O
HACR Circuit Breakers		Factory	O	O	O
Short-Circuit Current Rating (SCCR) of 100kA (includes Phase/Voltage Detection)		Factory	O	O	O
Disconnect Switch	80 amp	20W23	OX	OX	
	80 amp	22A25			OX
GFI Service Outlets	15 amp non-powered, field-wired	74M70	OX	OX	OX
Weatherproof Cover for GFI		10C89	X	X	X
Phase/Voltage Detection - 3 Phase Models Only		Factory	O	O	O
ECONOMIZER					
High Performance Economizer With Outdoor Air Hood (Sensible Control) (Approved for California Title 24 Building Standards / AMCA Class 1A Certified)					
High Performance Economizer - Includes Barometric Relief Dampers and Combination Hood		20H48	OX	OX	OX
High Performance Economizer - No Exhaust Option		Factory	O	O	O
Economizer Accessories					
Horizontal Economizer Conversion Kit		17W45	X	X	X
Economizer Controls (Not for Title 24)					
Differential Enthalpy	Order 2	21Z09	OX	OX	OX
Sensible Control	Sensor is Furnished	Factory	O	O	O
Single Enthalpy		21Z09	OX	OX	OX
Global Control	Sensor Field Provided	Factory	O	O	O
Building Pressure Control		13J77	X	X	X
POWER EXHAUST FAN					
Standard Static <i>NOTE - Factory or Field installed Power Exhaust Fan requires "Barometric Relief Dampers for Power Exhaust Kit" for field installation. See below.</i>	208/230V-1 or 3ph	21Z13	OX	OX	OX
	460V-3ph	21Z14	OX	OX	OX
BAROMETRIC RELIEF					
¹ Barometric Relief Dampers for Power Exhaust Kit		21Z21	X	X	X
² Horizontal Barometric Relief Dampers With Exhaust Hood		19F01	X	X	X
OUTDOOR AIR					
Outdoor Air Dampers With Outdoor Air Hood					
Motorized		15D17	OX	OX	OX
Manual		15D18	OX	OX	OX

¹ Required when Economizer is factory installed with factory installed Power Exhaust Fan option.

² Required when Economizer is configured for horizontal airflow.

NOTE - Catalog numbers shown are for ordering field installed accessories.

OX - Configure To Order (Factory Installed) or Field Installed

O = Configure To Order (Factory Installed)

X = Field Installed

OPTIONS / ACCESSORIES

Item	Catalog Number	Unit Model Number		
		036	048	060
HUMIDITROL® CONDENSER REHEAT OPTION				
Humiditrol Dehumidification Option	Factory	O	O	O
Humidity Sensor Kit, Remote mounted (required)	17M50	X	X	X

¹ Required when Economizer is factory installed with factory installed Power Exhaust Fan option.

² Required when Economizer is configured for horizontal airflow.

INDOOR AIR QUALITY

Air Filters

Healthy Climate® High Efficiency Air Filters	MERV 8 (16 x 20 x 2 in.)	54W20	OX	OX	
	MERV 13 (16 x 20 x 2 in.)	52W37	OX	OX	
Order 4 per unit	MERV 8 (20 x 20 x 2 in.)	54W21			OX
	MERV 13 (20 x 20 x 2 in.)	52W39			OX
Replaceable Media Filter With Metal Mesh Frame (includes non-pleated filter media)	16 x 20 x 2 in. (Order 4)	39W09	X	X	
	20 x 20 x 2 in. (Order 4)	44N60			X

Indoor Air Quality (CO₂) Sensors

Sensor - Wall-mount, off-white plastic cover with LCD display		77N39	X	X	X
Sensor - Wall-mount, off-white plastic cover, no display		87N53	X	X	X
Sensor - Black plastic case with LCD display, rated for plenum mounting		87N52	X	X	X
Sensor - Wall-mount, black plastic case, no display, rated for plenum mounting		87N54	X	X	X
CO ₂ Sensor Duct Mounting Kit - for downflow applications		85L43	X	X	X
Aspiration Box - for duct mounting non-plenum rated CO ₂ sensors (87N53 or 77N39)		90N43	X	X	X

UVC Germicidal Lamps

¹ Healthy Climate® UVC Light Kit (110/230v-1ph)		21A92	X	X	X
Step-Down Transformer	460V primary, 230V secondary	10H20	X	X	X

ROOF CURBS

Hybrid Roof Curbs, Downflow

8 in. height		11F50	X	X	X
14 in. height		11F51	X	X	X
18 in. height		11F52	X	X	X
24 in. height		11F53	X	X	X

Adjustable Pitched Curb

14 in. height		43W27	X	X	X
---------------	--	--------------	---	---	---

Transition Curb

Matches Emergence® 036-074 Units to existing L Series® Curbs		20W06	X	X	X
--	--	--------------	---	---	---

CEILING DIFFUSERS

Step-Down - Order one	RTD9-65S	13K60	X	X	X
Flush - Order one	FD9-65S	13K55	X	X	X
Transitions (Supply and Return) - Order one	T1TRAN10AN1	17W53	X	X	X

¹ Lamps operate on 110-230V single-phase power supply. Step-down transformer may be ordered separately for 460V units. Alternately, 110V power supply may be used to directly power the UVC ballast(s).

NOTE - Catalog numbers shown are for ordering field installed accessories.

OX - Configure To Order (Factory Installed) or Field Installed

O = Configure To Order (Factory Installed)

X = Field Installed

SPECIFICATIONS

General Data		Nominal Tonnage	3 Ton	4 Ton	5 Ton
		Model Number	LGH036H4E	LGH048H4E	LGH060H4E
		Efficiency Type	High	High	High
		Blower Type	Direct Drive (ECM)	Direct Drive (ECM)	Direct Drive (ECM)
Cooling Performance	Gross Cooling Capacity - Btuh		36,600	50,100	61,600
	¹ Net Cooling Capacity - Btuh		36,000	49,000	60,000
	AHRI Rated Air Flow - cfm		1200	1600	1750
	Total Unit Power - kW		2.8	3.8	4.7
	¹ SEER (Btuh/Watt) - 208/230V-1ph, 3ph		18.0	17.6	17.1
	¹ EER (Btuh/Watt) - 208/230V-1ph, 3ph		12.8	12.8	12.7
Refrigerant Charge	Refrigerant Type		R-410A	R-410A	R-410A
	Environ™ Coil System		4 lbs. 5 oz.	6 lbs. 4 oz.	8 lbs. 0 oz.
	Conventional Fin/Tube Coil		8 lbs. 8 oz.	11 lbs. 2 oz.	14 lbs. 0 oz.
	Environ™ Coil System With Humiditrol®		5 lbs. 2 oz.	6 lbs. 8 oz.	8 lbs. 0 oz.
	Conventional Fin/Tube With Humiditrol®		9 lbs. 3 oz.	12 lbs. 4 oz.	16 lbs. 0 oz.
Gas Heating Options Available - See page 20			Standard (2 stage), Medium (2 stage)	Standard (2 stage), Medium (2 stage)	Standard (2 stage), Medium (2 stage)
Compressor Type (one per unit)			Two-Stage Scroll	Two-Stage Scroll	Two-Stage Scroll
Outdoor Coil Environ™ (Fin/Tube)	Net face area (total) - sq. ft.		11.70 (15.60)	14.50 (15.60)	17.80 (19.30)
	Tube diameter - in.		0.71 (3/8)	0.71 (3/8)	0.71 (3/8)
	Number of rows		1 (1.5)	1 (2)	1 (2)
	Fins per inch		20 (20)	20 (20)	20 (20)
Outdoor Coil Fans	Motor - (No.) horsepower		(1) 1/3 (ECM)	(1) 1/3 (ECM)	(1) 1/3 (ECM)
	Motor rpm		715-810	645-810	930-1100
	Total Motor Input - watts		112-160	89-165	230-350
	Diameter - (No.) in.		(1) 24	(1) 24	(1) 24
	Number of blades		3	3	3
	Total air volume - cfm		3400-3795	2910-3675	4315-4980
Indoor Coil	Net face area (total) - sq. ft.		7.78	7.78	9.72
	Tube diameter - in.		3/8	3/8	3/8
	Number of rows		3	4	4
	Fins per inch		14	14	14
	Drain connection (Number) and size - in.		(1) 1 NPT	(1) 1 NPT	(1) 1 NPT
	Expansion device type		Balanced Port Thermostatic Expansion Valve, removable power head		
² Indoor Blower	Nominal motor HP		0.50 (ECM)	0.75 (ECM)	1 (ECM)
	Blower wheel nominal diameter x width - in.		(1) 10 X 10	(1) 10 X 10	(1) 11 X 10
Filters	Type of filter		disposable		
	Number and size - in.		(4) 16 X 20 X 2		(4) 20 x 20 x 2
Electrical characteristics			208/230V - 60 hz - 1 phase 208/230V or 460V - 60 hz -3 phase		

NOTE - Net capacity includes evaporator blower motor heat deduction. Gross capacity does not include evaporator blower motor heat deduction.

¹ AHRI Certified to AHRI Standard 210/240: 95°F outdoor air temperature and 80°F db/67°F wb entering evaporator air; minimum external duct static pressure.

² Using total air volume and system static pressure requirements determine from blower performance tables rpm and motor output required. Maximum usable output of motors furnished are shown. In Canada, nominal motor output is also maximum usable motor output. If motors of comparable output are used, be sure to keep within the service factor limitations outlined on the motor nameplate.

SPECIFICATIONS - GAS HEAT

Heat Input Type		Standard (2 Stage)	Medium (2 Stage)
Input Btuh	1st Stage	45,000	75,000
	2nd Stage	60,000	100,000
Output Btuh	1st Stage	37,000	62,000
	2nd Stage	48,000	80,000
Temperature Rise Range - °F	1st Stage	15 - 45	25 - 55
	2nd Stage	20 - 50	30 - 60
1 AFUE (Single Phase)		81%	81%
2 Thermal Efficiency (Three Phase)		80%	80%
Gas Supply Connections		1/2 in. NPT	
Rec. Gas Supply Pressure - Nat.		7 in. w.g. / 11 in. w.g.	

¹ Annual Fuel Utilization Efficiency based on U.S. DOE test procedures and FTC labeling regulations.

² Thermal Efficiency at full input.

HIGH ALTITUDE OPERATION

NOTE - Units may be installed at altitudes up to 4500 ft. above sea level without any modification. No modifications are required. At altitudes above 2000 ft. the furnace will naturally derate approximately 10%.

COOLING RATINGS

NOTE - For Temperatures and Capacities not shown in tables, see bulletin - Cooling Unit Rating Table Correction Factor Data in Miscellaneous Product Data section.

5 TON HIGH EFFICIENCY LGH060H4 (1ST STAGE)

Entering Wet Bulb Temperature	Total Air Volume	Outdoor Air Temperature Entering Outdoor Coil																			
		65°F					75°F					85°F					95°F				
		Total Cool Cap.	Comp. Motor Input	Sensible To Total Ratio (S/T)			Total Cool Cap.	Comp. Motor Input	Sensible To Total Ratio (S/T)			Total Cool Cap.	Comp. Motor Input	Sensible To Total Ratio (S/T)			Total Cool Cap.	Comp. Motor Input	Sensible To Total Ratio (S/T)		
				Dry Bulb					Dry Bulb					Dry Bulb					Dry Bulb		
cfm	kBtuh	kW	75°F	80°F	85°F	kBtuh	kW	75°F	80°F	85°F	kBtuh	kW	75°F	80°F	85°F	kBtuh	kW	75°F	80°F	85°F	
63°F	1070	47.4	1.82	0.66	0.79	0.92	45.5	2.14	0.67	0.8	0.94	43.5	2.49	0.68	0.82	0.97	41.5	2.87	0.7	0.85	0.99
	1335	50.1	1.81	0.71	0.85	1	48.2	2.13	0.72	0.88	1	46	2.48	0.73	0.91	1	43.7	2.86	0.75	0.93	1
	1600	52.3	1.8	0.75	0.93	1	50	2.13	0.77	0.95	1	47.9	2.48	0.79	0.98	1	45.5	2.86	0.8	1	1
67°F	1070	50.4	1.81	0.53	0.64	0.75	48.5	2.13	0.53	0.65	0.76	46.2	2.48	0.53	0.65	0.78	44.2	2.86	0.55	0.67	0.8
	1335	53.3	1.8	0.55	0.68	0.82	51.2	2.13	0.57	0.69	0.84	49	2.48	0.57	0.71	0.86	46.7	2.86	0.58	0.72	0.89
	1600	55.6	1.79	0.58	0.72	0.89	53.2	2.12	0.59	0.73	0.91	50.8	2.48	0.57	0.76	0.94	48.2	2.86	0.61	0.78	0.97
71°F	1070	53.6	1.8	0.41	0.51	0.62	51.5	2.12	0.41	0.52	0.62	49.3	2.47	0.41	0.52	0.63	47	2.86	0.42	0.53	0.65
	1335	56.7	1.79	0.42	0.54	0.66	54.4	2.12	0.43	0.55	0.67	51.9	2.47	0.43	0.56	0.68	49.5	2.86	0.43	0.57	0.7
	1600	58.9	1.78	0.43	0.57	0.7	56.5	2.12	0.44	0.58	0.71	53.9	2.47	0.44	0.58	0.72	51.2	2.86	0.45	0.6	0.75

5 TON HIGH EFFICIENCY LGH060H4 (2ND STAGE)

Entering Wet Bulb Temperature	Total Air Volume	Outdoor Air Temperature Entering Outdoor Coil																			
		85°F					95°F					105°F					115°F				
		Total Cool Cap.	Comp. Motor Input	Sensible To Total Ratio (S/T)			Total Cool Cap.	Comp. Motor Input	Sensible To Total Ratio (S/T)			Total Cool Cap.	Comp. Motor Input	Sensible To Total Ratio (S/T)			Total Cool Cap.	Comp. Motor Input	Sensible To Total Ratio (S/T)		
				Dry Bulb					Dry Bulb					Dry Bulb					Dry Bulb		
cfm	kBtuh	kW	75°F	80°F	85°F	kBtuh	kW	75°F	80°F	85°F	kBtuh	kW	75°F	80°F	85°F	kBtuh	kW	75°F	80°F	85°F	
63°F	1600	59.5	3.5	0.69	0.84	0.99	56.9	3.93	0.71	0.86	1	54	4.42	0.73	0.89	1	50.9	4.99	0.75	0.93	1
	2000	62.6	3.54	0.75	0.93	1	59.7	3.96	0.77	0.95	1	56.5	4.45	0.79	0.98	1	53.3	5.02	0.82	1	1
	2400	64.9	3.56	0.8	1	1	62.2	3.99	0.83	1	1	59.4	4.49	0.85	1	1	56.3	5.07	0.9	1	1
67°F	1600	63	3.54	0.54	0.67	0.8	60.2	3.97	0.56	0.68	0.82	57.3	4.46	0.57	0.7	0.85	53.9	5.03	0.58	0.72	0.88
	2000	66.4	3.58	0.59	0.73	0.89	63.2	4.01	0.59	0.74	0.92	59.7	4.5	0.6	0.76	0.94	56.4	5.07	0.62	0.79	0.98
	2400	68.4	3.61	0.61	0.78	0.97	65.2	4.03	0.63	0.8	0.99	61.6	4.52	0.64	0.83	1	58	5.09	0.65	0.87	1
71°F	1600	66.8	3.59	0.42	0.53	0.64	63.9	4.01	0.42	0.54	0.66	60.8	4.51	0.43	0.56	0.68	57.3	5.08	0.44	0.57	0.7
	2000	70.1	3.63	0.43	0.57	0.7	66.8	4.05	0.44	0.58	0.72	63.2	4.54	0.44	0.58	0.74	59.6	5.12	0.44	0.6	0.76
	2400	72.3	3.65	0.45	0.6	0.76	68.8	4.08	0.45	0.61	0.77	65.2	4.57	0.46	0.63	0.8	61.4	5.14	0.46	0.65	0.84

HUMIDITROL® DEHUMIDIFICATION SYSTEM RATINGS

3 TON HIGH EFFICIENCY LGH036H4 WITH HUMIDITROL® OPERATING

Entering Wet Bulb Temperature	Total Air Volume	Outdoor Air Temperature Entering Outdoor Coil																			
		65°F					75°F					85°F					95°F				
		Total Cool Cap.	Comp. Motor Input	Sensible To Total Ratio (S/T)			Total Cool Cap.	Comp. Motor Input	Sensible To Total Ratio (S/T)			Total Cool Cap.	Comp. Motor Input	Sensible To Total Ratio (S/T)			Total Cool Cap.	Comp. Motor Input	Sensible To Total Ratio (S/T)		
				Dry Bulb					Dry Bulb					Dry Bulb					Dry Bulb		
cfm	kBtuh	kW	75°F	80°F	85°F	kBtuh	kW	75°F	80°F	85°F	kBtuh	kW	75°F	80°F	85°F	kBtuh	kW	75°F	80°F	85°F	
63°F	640	22.6	1.52	0.49	0.63	0.77	18.9	1.73	0.42	0.59	0.76	15.2	1.94	0.32	0.53	0.75	11.4	2.17	0.14	0.43	0.70
	800	24.3	1.53	0.53	0.70	0.85	20.2	1.73	0.47	0.67	0.84	16.1	1.94	0.37	0.62	0.86	11.8	2.17	0.20	0.54	0.87
	960	25.6	1.54	0.57	0.75	0.94	21.1	1.74	0.51	0.74	0.95	16.5	1.95	0.43	0.72	0.98	11.9	2.17	0.26	0.66	1.00
67°F	640	25.5	1.54	0.36	0.48	0.61	21.8	1.75	0.28	0.43	0.57	18.0	1.96	0.17	0.35	0.52	14.1	2.19	-0.02	0.22	0.44
	800	27.4	1.56	0.38	0.52	0.67	23.3	1.76	0.30	0.47	0.64	19.0	1.97	0.18	0.39	0.60	14.6	2.20	-0.01	0.27	0.54
	960	28.8	1.57	0.40	0.57	0.72	24.3	1.77	0.32	0.51	0.71	19.7	1.98	0.20	0.44	0.68	15.2	2.20	0.01	0.28	0.64
71°F	640	28.2	1.56	0.25	0.37	0.48	24.5	1.77	0.16	0.30	0.43	20.7	1.98	0.05	0.21	0.36	16.8	2.22	-0.13	0.07	0.26
	800	30.4	1.58	0.25	0.39	0.52	26.2	1.78	0.17	0.32	0.47	22.0	1.99	0.05	0.23	0.41	17.4	2.23	-0.14	0.09	0.32
	960	31.9	1.60	0.27	0.41	0.56	27.4	1.79	0.18	0.35	0.52	22.7	2.00	0.04	0.25	0.46	17.9	2.23	-0.17	0.11	0.35

4 TON HIGH EFFICIENCY LGH048H4 WITH HUMIDITROL® OPERATING

Entering Wet Bulb Temperature	Total Air Volume	Outdoor Air Temperature Entering Outdoor Coil																			
		65°F					75°F					85°F					95°F				
		Total Cool Cap.	Comp. Motor Input	Sensible To Total Ratio (S/T)			Total Cool Cap.	Comp. Motor Input	Sensible To Total Ratio (S/T)			Total Cool Cap.	Comp. Motor Input	Sensible To Total Ratio (S/T)			Total Cool Cap.	Comp. Motor Input	Sensible To Total Ratio (S/T)		
				Dry Bulb					Dry Bulb					Dry Bulb					Dry Bulb		
cfm	kBtuh	kW	75°F	80°F	85°F	kBtuh	kW	75°F	80°F	85°F	kBtuh	kW	75°F	80°F	85°F	kBtuh	kW	75°F	80°F	85°F	
63°F	890	30.4	2.14	0.46	0.61	0.76	25.5	2.37	0.40	0.57	0.75	20.4	2.61	0.30	0.52	0.74	15.1	2.90	0.14	0.43	0.71
	1115	32.4	2.17	0.51	0.68	0.86	26.8	2.40	0.45	0.65	0.87	21.1	2.65	0.36	0.61	0.89	15.2	2.93	0.19	0.55	0.91
	1340	33.7	2.19	0.55	0.76	0.96	27.6	2.42	0.49	0.74	0.99	21.3	2.67	0.41	0.72	1.00	14.8	2.95	0.24	0.69	0.99
67°F	890	34.5	2.17	0.33	0.46	0.59	29.5	2.40	0.26	0.40	0.55	24.4	2.65	0.15	0.32	0.51	19.0	2.93	-0.02	0.21	0.44
	1115	36.6	2.20	0.35	0.50	0.66	30.9	2.43	0.28	0.45	0.62	25.3	2.68	0.16	0.37	0.59	19.1	2.96	-0.03	0.26	0.54
	1340	38.2	2.23	0.38	0.55	0.72	32.7	2.45	0.29	0.47	0.71	25.5	2.70	0.18	0.43	0.69	18.9	2.98	-0.02	0.32	0.65
71°F	890	38.7	2.20	0.23	0.33	0.45	33.6	2.43	0.15	0.27	0.40	28.4	2.68	0.04	0.19	0.34	23.0	2.96	-0.12	0.06	0.24
	1115	41.1	2.23	0.23	0.36	0.49	35.4	2.46	0.14	0.29	0.45	29.4	2.71	0.03	0.21	0.39	23.3	2.99	-0.16	0.08	0.30
	1340	42.7	2.26	0.24	0.38	0.54	36.9	2.48	0.15	0.31	0.50	29.9	2.73	0.02	0.23	0.42	23.4	3.01	-0.19	0.09	0.36

5 TON HIGH EFFICIENCY LGH060H4 WITH HUMIDITROL® OPERATING

Entering Wet Bulb Temperature	Total Air Volume	Outdoor Air Temperature Entering Outdoor Coil																			
		65°F					75°F					85°F					95°F				
		Total Cool Cap.	Comp. Motor Input	Sensible To Total Ratio (S/T)			Total Cool Cap.	Comp. Motor Input	Sensible To Total Ratio (S/T)			Total Cool Cap.	Comp. Motor Input	Sensible To Total Ratio (S/T)			Total Cool Cap.	Comp. Motor Input	Sensible To Total Ratio (S/T)		
				Dry Bulb					Dry Bulb					Dry Bulb					Dry Bulb		
cfm	kBtuh	kW	75°F	80°F	85°F	kBtuh	kW	75°F	80°F	85°F	kBtuh	kW	75°F	80°F	85°F	kBtuh	kW	75°F	80°F	85°F	
63°F	1080	36.2	2.76	0.43	0.59	0.74	29.8	3.07	0.35	0.53	0.73	23.3	3.41	0.21	0.44	0.69	16.4	3.78	-0.03	0.29	0.63
	1350	39.2	2.79	0.48	0.64	0.85	31.6	3.09	0.40	0.62	0.84	24.2	3.42	0.26	0.55	0.84	16.6	3.78	0.02	0.43	0.84
	1620	40.8	2.81	0.52	0.73	0.94	33.5	3.11	0.46	0.66	0.96	24.7	3.43	0.32	0.66	0.98	16.6	3.79	0.07	0.57	1.00
67°F	1080	41.5	2.81	0.30	0.43	0.57	35.3	3.12	0.21	0.36	0.52	28.3	3.46	0.07	0.26	0.45	21.3	3.84	-0.16	0.10	0.34
	1350	44.5	2.84	0.33	0.48	0.63	37.1	3.15	0.23	0.41	0.60	29.7	3.48	0.08	0.31	0.53	22.0	3.85	-0.16	0.14	0.44
	1620	46.8	2.87	0.35	0.52	0.69	38.9	3.17	0.26	0.45	0.67	31.5	3.50	0.05	0.29	0.63	22.1	3.86	-0.16	0.20	0.56
71°F	1080	47.2	2.86	0.20	0.31	0.43	40.5	3.18	0.10	0.23	0.37	33.6	3.52	-0.03	0.13	0.28	26.5	3.90	-0.24	-0.04	0.16
	1350	50.4	2.90	0.20	0.33	0.47	43.0	3.21	0.10	0.26	0.42	35.4	3.55	-0.04	0.15	0.34	27.5	3.92	-0.28	-0.03	0.21
	1620	52.9	2.93	0.21	0.36	0.51	44.6	3.23	0.10	0.28	0.46	36.4	3.56	-0.05	0.16	0.39	28.4	3.93	-0.30	-0.05	0.27

BLOWER DATA

BLOWER TABLE INCLUDES RESISTANCE FOR BASE UNIT ONLY WITH DRY INDOOR COIL AND AIR FILTERS IN PLACE.

FOR ALL UNITS ADD:

1 - Any factory installed options air resistance (heat section, economizer, etc.).

2 - Any field installed accessories air resistance (duct resistance, diffuser, etc.).

See page 27 for wet coil and options/accessory air resistance data.

DOWNFLOW

External Static Press. in. w.g.	Percentage of Total Motor Torque																												
	20%			30%			40%			50%			60%			70%			80%			90%			100%				
	Cfm	RPM	Watts	Cfm	RPM	Watts	Cfm	RPM	Watts	Cfm	RPM	Watts	Cfm	RPM	Watts	Cfm	RPM	Watts	Cfm	RPM	Watts	Cfm	RPM	Watts	Cfm	RPM	Watts	Cfm	RPM
0	796	39	407	975	69	451	1154	98	494	1298	140	567	1442	181	639	1570	236	692	1697	292	744	1807	357	785	1917	422	825		
0.1	719	44	482	915	76	523	1110	108	564	1257	151	626	1404	193	687	1537	248	733	1670	304	779	1784	369	815	1898	433	850		
0.2	663	49	538	864	83	585	1064	117	633	1220	160	679	1375	203	725	1508	259	770	1641	316	815	1754	384	853	1866	452	891		
0.3	593	55	607	806	91	651	1018	126	695	1174	171	737	1330	216	780	1471	272	815	1612	328	850	1724	398	890	1835	469	930		
0.4	527	60	665	749	97	708	971	135	751	1136	180	783	1300	225	815	1435	285	858	1569	344	900	1689	413	930	1809	481	959		
0.5	460	65	722	692	104	761	924	143	801	1090	190	833	1256	238	866	1398	296	899	1540	355	932	1662	424	960	1784	493	988		
0.6	---	---	---	---	---	---	855	154	864	1033	202	889	1211	250	914	1361	308	939	1511	365	963	1629	437	995	1746	508	1028		
0.7	---	---	---	---	---	---	808	161	898	995	209	922	1181	258	946	1325	319	976	1468	379	1007	1588	450	1036	1708	522	1065		
0.8	---	---	---	---	---	---	743	170	942	940	220	966	1137	269	991	1281	331	1020	1425	392	1049	1548	463	1074	1670	533	1100		
0.9	---	---	---	---	---	---	676	178	979	884	229	1006	1092	280	1033	1237	342	1061	1381	404	1088	1513	472	1105	1645	539	1121		
1.0	---	---	---	---	---	---	605	187	1011	819	240	1049	1032	294	1087	1192	353	1100	1352	411	1112	1474	480	1137	1595	549	1161		
1.1	---	---	---	---	---	---	---	---	---	---	---	---	988	304	1124	1142	364	1141	1295	424	1158	1420	490	1177	1544	555	1195		
1.2	---	---	---	---	---	---	---	---	---	---	---	---	---	---	---	---	---	---	1251	433	1189	1373	495	1207	1494	558	1225		

HORIZONTAL

External Static Press. in. w.g.	Percentage of Total Motor Torque																												
	20%			30%			40%			50%			60%			70%			80%			90%			100%				
	Cfm	RPM	Watts	Cfm	RPM	Watts	Cfm	RPM	Watts	Cfm	RPM	Watts	Cfm	RPM	Watts	Cfm	RPM	Watts	Cfm	RPM	Watts	Cfm	RPM	Watts	Cfm	RPM	Watts	Cfm	RPM
0	807	44	372	982	65	431	1157	86	490	1299	126	546	1441	167	602	1565	214	647	1688	262	692	1795	328	734	1901	393	776		
0.1	708	50	468	906	77	513	1103	104	559	1247	143	612	1391	183	666	1522	231	704	1652	280	742	1766	346	779	1879	413	815		
0.2	634	56	541	841	88	583	1048	120	625	1206	156	663	1363	192	701	1491	243	742	1619	294	783	1731	361	820	1843	429	857		
0.3	523	63	648	759	98	669	994	134	690	1150	171	729	1306	209	769	1446	258	796	1585	307	823	1696	376	860	1807	444	896		
0.4	437	69	732	688	107	742	939	146	752	1101	183	785	1263	221	818	1399	273	849	1535	326	881	1653	392	908	1771	458	935		
0.5	344	75	823	615	116	817	885	156	812	1053	194	838	1220	232	865	1361	285	892	1502	339	918	1614	406	949	1725	473	980		
0.6	---	---	---	---	---	---	817	167	883	990	207	905	1162	246	927	1307	301	949	1451	356	971	1570	420	993	1689	484	1014		
0.7	---	---	---	---	---	---	762	174	938	941	215	954	1119	256	971	1269	312	988	1418	367	1005	1536	430	1026	1653	494	1047		
0.8	---	---	---	---	---	---	708	178	991	892	222	1002	1076	266	1013	1222	324	1034	1368	383	1054	1484	444	1073	1599	506	1092		
0.9	---	---	---	---	---	---	645	182	1050	832	230	1059	1019	277	1068	1168	337	1084	1317	397	1100	1431	456	1117	1545	516	1134		
1.0	---	---	---	---	---	---	584	184	1105	780	235	1106	976	285	1107	1122	348	1125	1267	411	1144	1379	467	1158	1491	522	1172		
1.1	---	---	---	---	---	---	---	---	---	---	---	---	923	295	1155	1070	359	1169	1217	423	1184	1327	475	1195	1436	526	1207		
1.2	---	---	---	---	---	---	---	---	---	---	---	---	---	---	---	---	---	---	1166	434	1222	1265	481	1234	1364	527	1246		

BLOWER DATA**BLOWER TABLE INCLUDES RESISTANCE FOR BASE UNIT ONLY WITH DRY INDOOR COIL AND AIR FILTERS IN PLACE.**

FOR ALL UNITS ADD:

1 - Any factory installed options air resistance (heat section, economizer, etc.).

2 - Any field installed accessories air resistance (duct resistance, diffuser, etc.).

See page 27 for wet coil and options/accessory air resistance data.

DOWNFLOW

External Static Press. in. w.g.	Percentage of Total Motor Torque																																			
	20%			30%			40%			50%			60%			70%			80%			90%			100%											
	Cfm	RPM	Watts	Cfm	RPM	Watts	Cfm	RPM	Watts	Cfm	RPM	Watts	Cfm	RPM	Watts	Cfm	RPM	Watts	Cfm	RPM	Watts	Cfm	RPM	Watts	Cfm	RPM	Watts	Cfm	RPM	Watts	Cfm	RPM	Watts	Cfm	RPM	Watts
0	1048	80	507	1261	135	582	1473	190	657	1655	274	729	1836	359	801	1987	461	863	2137	563	924	2291	698	975	2445	832	1025									
0.1	1000	88	560	1218	146	633	1436	204	706	1624	289	771	1812	374	836	1965	479	896	2118	583	956	2261	716	1004	2403	849	1052									
0.2	944	97	624	1177	156	683	1409	214	743	1595	304	812	1781	393	881	1940	497	934	2098	602	986	2235	729	1032	2372	856	1077									
0.3	906	104	666	1139	166	728	1372	228	790	1561	320	858	1750	412	925	1915	515	970	2079	619	1015	2210	741	1058	2341	863	1100									
0.4	849	113	728	1093	177	783	1336	241	837	1531	333	897	1726	425	957	1889	532	1004	2052	639	1051	2177	754	1090	2302	869	1129									
0.5	793	121	790	1047	188	837	1300	254	883	1501	346	935	1702	438	987	1864	548	1036	2026	657	1085	2145	766	1120	2263	874	1155									
0.6	---	---	---	---	---	---	1263	267	929	1467	361	978	1671	454	1027	1836	564	1071	2000	673	1116	2116	775	1145	2232	876	1175									
0.7	---	---	---	---	---	---	1226	280	974	1433	375	1019	1639	470	1065	1807	578	1104	1974	686	1144	2080	782	1173	2186	878	1203									
0.8	---	---	---	---	---	---	1195	291	1012	1402	388	1057	1608	485	1101	1778	591	1135	1948	697	1169	2052	787	1195	2155	878	1220									
0.9	---	---	---	---	---	---	1162	304	1060	1367	401	1097	1572	498	1134	1741	603	1168	1909	708	1202	2009	792	1223	2109	875	1244									
1.0	---	---	---	---	---	---	1133	316	1104	1333	414	1136	1533	511	1167	1702	612	1198	1870	714	1229	1959	791	1251	2047	868	1272									
1.1	---	---	---	---	---	---	---	---	---	---	---	---	1490	524	1200	1654	618	1228	1817	713	1256	1909	786	1273	2000	859	1289									
1.2	---	---	---	---	---	---	---	---	---	---	---	---	---	---	---	---	---	---	---	---	---	---	---	---	---	---	---	---								

HORIZONTAL

External Static Press. in. w.g.	Percentage of Total Motor Torque																																			
	20%			30%			40%			50%			60%			70%			80%			90%			100%											
	Cfm	RPM	Watts	Cfm	RPM	Watts	Cfm	RPM	Watts	Cfm	RPM	Watts	Cfm	RPM	Watts	Cfm	RPM	Watts	Cfm	RPM	Watts	Cfm	RPM	Watts	Cfm	RPM	Watts	Cfm	RPM	Watts	Cfm	RPM	Watts	Cfm	RPM	Watts
0	1025	80	472	1238	131	552	1450	182	632	1626	254	702	1802	326	771	1936	414	824	2071	502	878	2231	634	931	2391	767	983									
0.1	978	85	546	1199	138	610	1420	191	675	1601	265	738	1781	339	801	1930	441	862	2079	544	923	2222	663	968	2365	783	1013									
0.2	927	89	602	1157	145	661	1387	201	720	1568	279	783	1749	357	845	1906	458	897	2062	559	949	2205	679	993	2348	798	1038									
0.3	851	98	684	1098	156	731	1344	214	777	1531	295	833	1717	375	888	1876	478	938	2035	581	988	2166	694	1030	2297	807	1072									
0.4	801	105	738	1051	166	785	1300	227	832	1493	309	881	1685	392	930	1847	496	977	2009	600	1023	2128	707	1064	2247	813	1105									
0.5	725	118	817	991	179	850	1256	239	883	1455	324	926	1653	408	970	1814	516	1019	1974	623	1068	2091	720	1099	2207	817	1130									
0.6	---	---	---	---	---	---	1212	251	931	1417	337	969	1621	423	1008	1784	531	1053	1947	638	1098	2057	729	1126	2166	820	1154									
0.7	---	---	---	---	---	---	1169	263	975	1380	350	1010	1590	437	1045	1756	544	1086	1921	651	1127	2014	736	1157	2106	821	1187									
0.8	---	---	---	---	---	---	1114	277	1027	1331	366	1059	1547	454	1091	1717	560	1126	1886	666	1161	1976	743	1184	2066	821	1207									
0.9	---	---	---	---	---	---	1062	290	1077	1283	380	1106	1504	470	1135	1669	575	1170	1833	680	1204	1919	749	1220	2005	817	1236									
1.0	---	---	---	---	---	---	1007	304	1127	1240	392	1147	1473	481	1166	1627	584	1202	1780	687	1238	1853	748	1253	1925	809	1269									
1.1	---	---	---	---	---	---	---	---	---	---	---	---	1429	497	1211	1569	590	1240	1709	683	1269	1787	741	1280	1864	799	1291									
1.2	---	---	---	---	---	---	---	---	---	---	---	---	---	---	---	---	---	---	---	---	---	---	---	---	---	---	---	---								

BLOWER DATA

BLOWER TABLE INCLUDES RESISTANCE FOR BASE UNIT ONLY WITH DRY INDOOR COIL AND AIR FILTERS IN PLACE.

FOR ALL UNITS ADD:

- 1 - Any factory installed options air resistance (heat section, economizer, etc.).
- 2 - Any field installed accessories air resistance (duct resistance, diffuser, etc.).

See page 27 for wet coil and options/accessory air resistance data.

DOWNFLOW

External Static Press. in. w.g.	Percentage of Total Motor Torque																													
	20%			30%			40%			50%			60%			70%			80%			90%			100%					
	Cfm	RPM	Watts	Cfm	RPM	Watts	Cfm	RPM	Watts	Cfm	RPM	Watts	Cfm	RPM	Watts	Cfm	RPM	Watts	Cfm	RPM	Watts	Cfm	RPM	Watts	Cfm	RPM	Watts	Cfm	RPM	Watts
0	1132	79	438	1353	146	524	1575	212	610	1765	300	670	1954	388	730	2126	513	796	2298	638	861	2445	792	913	2591	946	965			
0.1	1061	86	494	1305	155	568	1548	223	641	1743	315	702	1937	407	764	2110	531	823	2282	654	883	2426	808	935	2570	963	987			
0.2	990	94	550	1253	165	614	1516	236	678	1716	330	735	1916	423	793	2088	549	851	2260	675	910	2405	827	959	2549	979	1009			
0.3	920	102	606	1202	175	659	1484	248	713	1687	345	770	1890	442	828	2065	568	882	2239	694	937	2384	844	983	2528	994	1030			
0.4	849	111	662	1151	185	705	1452	260	747	1658	360	804	1863	460	861	2041	586	911	2218	713	962	2363	861	1006	2508	1009	1050			
0.5	779	121	718	1094	198	754	1410	275	790	1626	374	838	1842	473	886	2020	601	936	2197	730	987	2342	876	1028	2487	1023	1070			
0.6	---	---	---	---	---	---	1368	289	830	1589	390	876	1810	492	921	1993	619	966	2176	746	1010	2316	895	1054	2456	1043	1099			
0.7	---	---	---	---	---	---	1325	303	868	1552	406	911	1778	509	954	1966	635	993	2154	761	1033	2295	908	1075	2435	1055	1117			
0.8	---	---	---	---	---	---	1261	321	920	1504	423	952	1746	524	984	1934	653	1024	2122	782	1064	2268	925	1100	2414	1067	1135			
0.9	---	---	---	---	---	---	1211	337	964	1462	437	988	1714	538	1012	1902	669	1053	2090	801	1094	2237	942	1127	2383	1084	1161			
1.0	---	---	---	---	---	---	1151	354	1013	1412	454	1029	1672	553	1045	1871	682	1078	2069	811	1112	2211	955	1149	2352	1099	1185			
1.1	---	---	---	---	---	---	---	---	---	---	---	---	1629	566	1073	1828	698	1109	2027	830	1146	2174	971	1177	2321	1112	1208			
1.2	---	---	---	---	---	---	---	---	---	---	---	---	---	---	---	---	---	---	1984	844	1175	2137	984	1202	2290	1124	1230			

HORIZONTAL

External Static Press. in. w.g.	Percentage of Total Motor Torque																													
	20%			30%			40%			50%			60%			70%			80%			90%			100%					
	Cfm	RPM	Watts	Cfm	RPM	Watts	Cfm	RPM	Watts	Cfm	RPM	Watts	Cfm	RPM	Watts	Cfm	RPM	Watts	Cfm	RPM	Watts	Cfm	RPM	Watts	Cfm	RPM	Watts	Cfm	RPM	Watts
0	1127	82	426	1367	141	504	1607	200	582	1806	296	644	2005	391	706	2167	495	764	2328	599	822	2463	749	872	2598	899	922			
0.1	1071	86	476	1326	148	543	1580	210	610	1781	311	675	1981	411	740	2145	516	795	2309	620	849	2456	775	898	2602	931	947			
0.2	1010	91	529	1268	160	598	1525	229	668	1735	332	724	1945	434	781	2117	537	828	2289	640	875	2438	795	921	2587	949	967			
0.3	930	100	597	1214	169	647	1497	239	696	1707	345	755	1917	452	814	2093	556	857	2269	660	900	2417	817	948	2565	975	995			
0.4	869	109	646	1156	184	699	1442	258	751	1665	364	798	1888	469	845	2066	577	889	2243	685	933	2393	842	978	2543	998	1022			
0.5	813	119	689	1114	193	734	1414	267	778	1637	376	827	1860	485	876	2039	597	920	2217	709	963	2373	861	1002	2528	1013	1040			
0.6	---	---	---	---	---	---	1358	286	831	1595	394	868	1832	501	905	2012	616	949	2191	731	993	2349	882	1028	2506	1033	1064			
0.7	---	---	---	---	---	---	1330	296	857	1560	409	903	1789	523	949	1977	638	985	2164	753	1020	2324	902	1054	2484	1052	1088			
0.8	---	---	---	---	---	---	1275	315	908	1518	426	942	1761	536	977	1950	655	1011	2138	773	1046	2296	923	1081	2454	1073	1116			
0.9	---	---	---	---	---	---	1233	329	946	1483	439	975	1732	549	1004	1922	670	1037	2112	792	1071	2272	939	1104	2432	1087	1136			
1.0	---	---	---	---	---	---	1192	343	982	1441	455	1012	1690	567	1043	1881	692	1074	2072	818	1105	2237	960	1133	2402	1102	1161			
1.1	---	---	---	---	---	---	---	---	---	---	---	---	1662	578	1068	1854	706	1097	2046	833	1126	2206	975	1157	2365	1117	1188			
1.2	---	---	---	---	---	---	---	---	---	---	---	---	---	---	---	---	---	---	1994	861	1163	2165	993	1185	2336	1125	1206			

BLOWER DATA

FACTORY INSTALLED OPTIONS/FIELD INSTALLED ACCESSORY AIR RESISTANCE - in. w.g.

Air Volume cfm	Wet Indoor Coil			Humiditrol Dehumidification Coil	Gas Heating		Economizer	Filters	
	036	048	060		Low Heat	Medium Heat		MERV 8	MERV 13
036-048 MODELS									
800	0.01	0.01	---	0.00			0.04	0.04	0.05
1000	0.02	0.02	0.02	0.00			0.04	0.04	0.07
1200	0.03	0.04	0.04	0.01			0.04	0.04	0.07
1400	0.04	0.05	0.05	0.02			0.04	0.04	0.07
1600	0.05	0.06	0.07	0.03			0.04	0.04	0.07
1800	0.06	0.07	0.08	0.04			0.05	0.04	0.07
2000	0.08	0.09	0.10	0.04			0.05	0.05	0.08
2200	---	---	0.11	0.04			0.05	0.05	0.08
2400	---	---	0.13	0.04			0.05	0.05	0.08
2600	---	---	0.15	0.05			0.06	0.05	0.08

POWER EXHAUST FAN PERFORMANCE

Return Air System Static Pressure in. w.g.	Air Volume Exhausted cfm
0.00	2000
0.05	1990
0.10	1924
0.15	1810
0.20	1664
0.25	1507
0.30	1350
0.35	1210

CEILING DIFFUSERS AIR RESISTANCE (in. w.g.)

Air Volume cfm	RTD9-65S Step-Down Diffuser			FD9-65S Flush Diffuser
	2 Ends Open	1 Side & 2 Ends Open	All Ends & Sides Open	
800	0.15	0.13	0.11	0.11
1000	0.19	0.16	0.14	0.14
1200	0.25	0.20	0.17	0.17
1400	0.33	0.26	0.20	0.20
1600	0.43	0.32	0.20	0.24
1800	0.56	0.40	0.30	0.30
2000	0.73	0.50	0.36	0.36
2200	0.95	0.63	0.44	0.44

CEILING DIFFUSER AIR THROW DATA

Air Volume - cfm	¹ Effective Throw - ft.	
	RTD9-65S	FD9-65S
800	10 - 17	14 - 18
1000	10 - 17	15 - 20
1200	11 - 18	16 - 22
1400	12 - 19	17 - 24
1600	12 - 20	18 - 25
1800	13 - 21	20 - 28
2000	14 - 23	21 - 29
2200	16 - 25	22 - 30

¹ Effective throw based on terminal velocities of 75 ft. per minute.

ELECTRICAL DATA**3 TON**

Model No.		LGH036H4		
¹ Voltage - 60hz		208/230V - 1 Ph	208/230V - 3 Ph	460V - 3 Ph
Compressor	Rated Load Amps	14.2	8.8	4
	Locked Rotor Amps	78.1	70	31
Outdoor Fan Motor	Full Load Amps	4.1	4.1	2.1
Power Exhaust (1) 0.33 HP	Full Load Amps	2.4	2.4	1.3
Service Outlet 115V GFI (amps)		15	15	15
Indoor Blower Motor	Horsepower	0.5	0.5	0.5
	Full Load Amps	4.3	4.3	2.2
² Maximum Overcurrent Protection	Unit Only	40	25	15
	With (1) 0.33 HP Power Exhaust	40	30	15
³ Minimum Circuit Ampacity	Unit Only	27	20	10
	With (1) 0.33 HP Power Exhaust	29	22	11

NOTE - All units have a minimum Short Circuit Current Rating (SCCR) of 5000 amps.

¹ Extremes of operating range are plus and minus 10% of line voltage.² HACR type breaker or fuse.³ Refer to National or Canadian Electrical Code manual to determine wire, fuse and disconnect size requirements.**ELECTRICAL DATA****4 TON**

Model No.		LGH048H4		
¹ Voltage - 60hz		208/230V - 1 Ph	208/230V - 3 Ph	460V - 3 Ph
Compressor	Rated Load Amps	17.1	11.7	5.7
	Locked Rotor Amps	109	123	60
Outdoor Fan Motor	Full Load Amps	4.1	4.1	2.1
Power Exhaust (1) 0.33 HP	Full Load Amps	2.4	2.4	1.3
Service Outlet 115V GFI (amps)		15	15	15
Indoor Blower Motor	Horsepower	0.75	0.75	0.75
	Full Load Amps	6.1	6.1	3.1
² Maximum Overcurrent Protection	Unit Only	45	35	15
	With (1) 0.33 HP Power Exhaust	50	35	15
³ Minimum Circuit Ampacity	Unit Only	32	25	13
	With (1) 0.33 HP Power Exhaust	34	28	14

NOTE - All units have a minimum Short Circuit Current Rating (SCCR) of 5000 amps.

¹ Extremes of operating range are plus and minus 10% of line voltage.² HACR type breaker or fuse.³ Refer to National or Canadian Electrical Code manual to determine wire, fuse and disconnect size requirements.

ELECTRICAL DATA**5 TON**

Model No.		LGH060H4		
¹ Voltage - 60hz		208/230V - 1 Ph	208/230V - 3 Ph	460V - 3 Ph
Compressor	Rated Load Amps	23.5	14	6.5
	Locked Rotor Amps	118	93	60
Outdoor Fan Motor	Full Load Amps	4.1	4.1	2.1
Power Exhaust (1) 0.33 HP	Full Load Amps	2.4	2.4	1.3
Service Outlet 115V GFI (amps)		15	15	15
Indoor Blower Motor	Horsepower	1	1	1
	Full Load Amps	7.4	7.4	3.7
² Maximum Overcurrent Protection	Unit Only	60	40	20
	With (1) 0.33 HP Power Exhaust	60	45	20
³ Minimum Circuit Ampacity	Unit Only	41	29	14
	With (1) 0.33 HP Power Exhaust	44	32	16

NOTE - All units have a minimum Short Circuit Current Rating (SCCR) of 5000 amps.

¹ Extremes of operating range are plus and minus 10% of line voltage.

² HACR type breaker or fuse.

³ Refer to National or Canadian Electrical Code manual to determine wire, fuse and disconnect size requirements.

OUTDOOR SOUND DATA

¹ Unit Model No.	Octave Band Sound Power Levels dBA, re 10 ⁻¹² Watts Center Frequency - Hz							¹ Sound Rating Number dBA
	125	250	500	1000	2000	4000	8000	
036, 048	63	66	70	71	68	62	53	75
060	67	72	77	76	73	68	61	82

NOTE - The octave sound power data does not include tonal corrections.

¹ Sound Rating Number according to AHRI Standard 270-95 (includes pure tone penalty). Sound Rating Number is the overall A-Weighted Sound Power Level, (Lwa), dBA (100 Hz to 10,000 Hz).

WEIGHT DATA

Model Number	Outdoor Coil	Net		Shipping		Outdoor Coil	Net		Shipping	
		lbs.	kg	lbs.	kg		lbs.	kg	lbs.	kg
036 Base Unit	Environ™	549	249	610	277	Fin/Tube	568	257	629	285
036 Max. Unit	Environ™	743	337	804	365	Fin/Tube	762	346	823	373
048 Base Unit	Environ™	565	256	626	284	Fin/Tube	598	271	659	299
048 Max. Unit	Environ™	754	342	834	378	Fin/Tube	806	366	867	393
060 Base Unit	Environ™	643	292	704	319	Fin/Tube	685	311	746	338
060 Max. Unit	Environ™	871	395	932	423	Fin/Tube	913	414	974	442

OPTIONS / ACCESSORIES

	Shipping Weight		
	lbs.	kg	
ECONOMIZER / OUTDOOR AIR / EXHAUST			
Economizer			
Economizer, Includes Combination Outdoor Air Hood and Barometric Relief Dampers	131	59	
Outdoor Air Dampers			
Motorized	40	18	
Manual	30	14	
Power Exhaust			
Standard Static	35	17	
GAS HEAT			
Medium Heat (adder over low heat)	8	4	
PACKAGING			
LTL Packaging (less than truck load)	60	27	
ROOF CURBS			
Hybrid Roof Curbs, Downflow			
8 in. height	C1CURB70A-1	50	23
14 in. height	C1CURB71A-1	70	32
18 in. height	C1CURB72A-1	80	36
24 in. height	C1CURB73A-1	100	45
Adjustable Pitch Curb, Downflow			
14 in. height		113	51
CEILING DIFFUSERS			
Step-Down	RTD9-65S	80	36
Flush	FD9-65S	80	36
Transitions	T1TRAN10AN1	22	10
HUMIDITROL® DEHUMIDIFICATION SYSTEM			
Humiditrol Dehumidification Option (Net Weight)		27	12

UNIT CLEARANCES

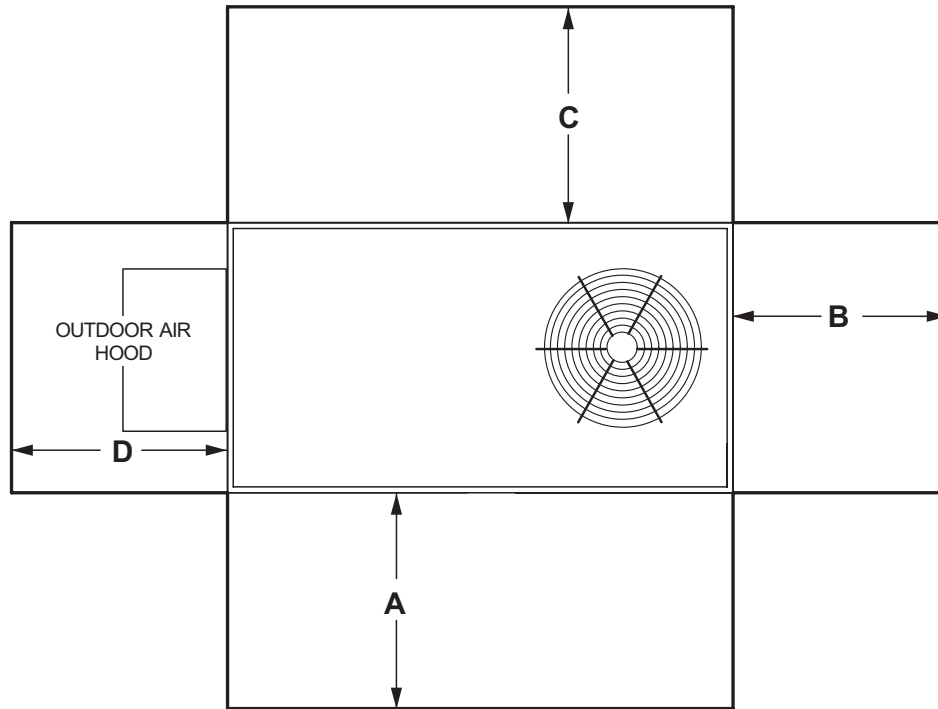

1 Unit Clearance	A		B		C		D		Top Clearance
	in.	mm	in.	mm	in.	mm	in.	mm	
Service Clearance	48	1219	36	914	36	934	36	914	Unobstructed
Clearance to Combustibles	36	914	1	25	1	25	1	25	
Minimum Operation Clearance	36	914	36	914	36	914	36	914	

NOTE - Entire perimeter of unit base requires support when elevated above the mounting surface.

¹ **Service Clearance** - Required for removal of serviceable parts.

Clearance to Combustibles - Required clearance to combustible material.

Minimum Operation Clearance - Required clearance for proper unit operation.

DIMENSIONS - UNIT

CORNER WEIGHTS

Model No.	AA		BB		CC		DD		EE		FF	
	lbs.	kg	lbs.	kg	lbs.	kg	lbs.	kg	in.	mm	in.	mm
LGH036 Base Unit	98	45	119	54	192	87	158	72	38.5	978	18	457
LGH036 Max. Unit	137	62	155	70	250	113	221	100	40	1016	18	457
LGH048 Base Unit	104	47	126	57	202	92	167	76	38.5	978	18	457
LGH048 Max. Unit	145	66	164	74	264	120	233	106	40	1016	18	457
LGH060 Base Unit	118	54	144	65	232	105	191	87	38.5	978	18	457
LGH060 Max. Unit	164	75	186	84	299	136	264	120	40	1016	18	457

Base Unit - The unit with NO INTERNAL OPTIONS.

Max. Unit - The unit with ALL INTERNAL OPTIONS Installed. (Economizer, Standard Static Power Exhaust Fans, Controls, etc.). Does not include accessories external to unit or high static power exhaust.

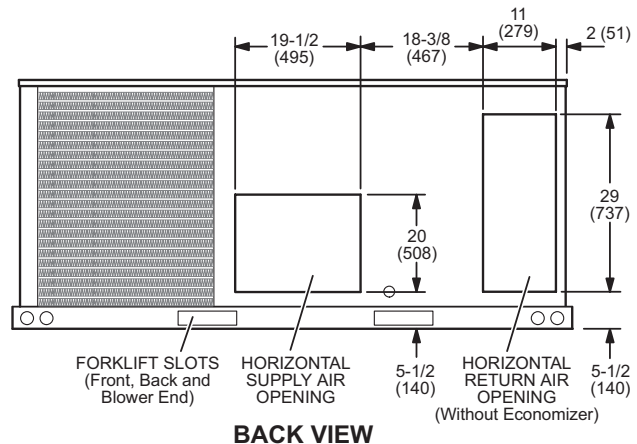
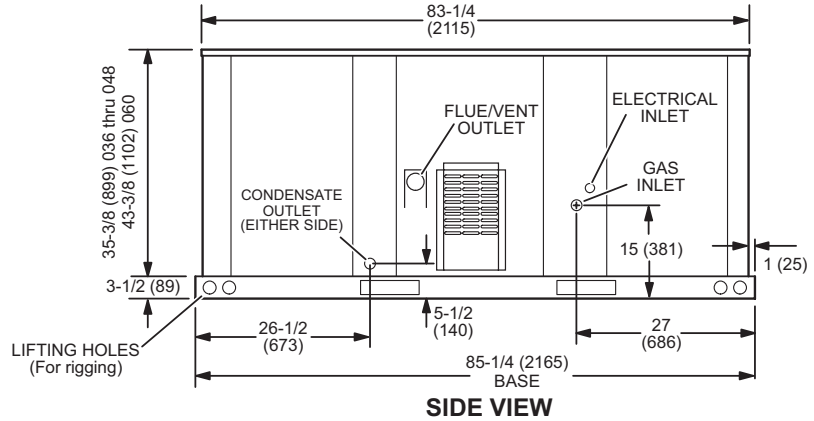
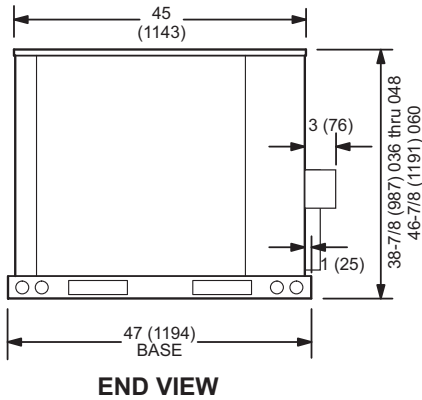
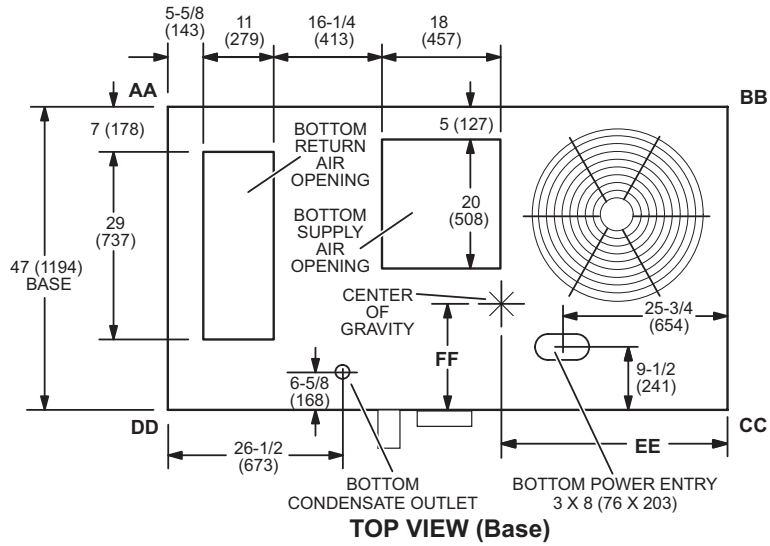

OUTDOOR AIR DAMPER HOOD DETAIL (Downflow or Horizontal Applications)

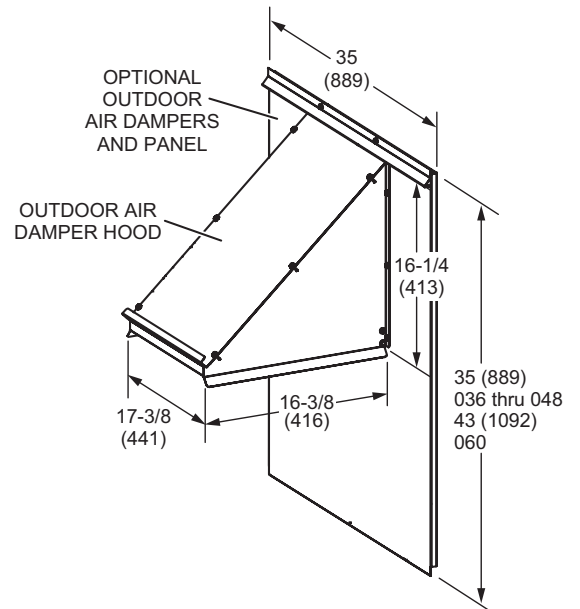
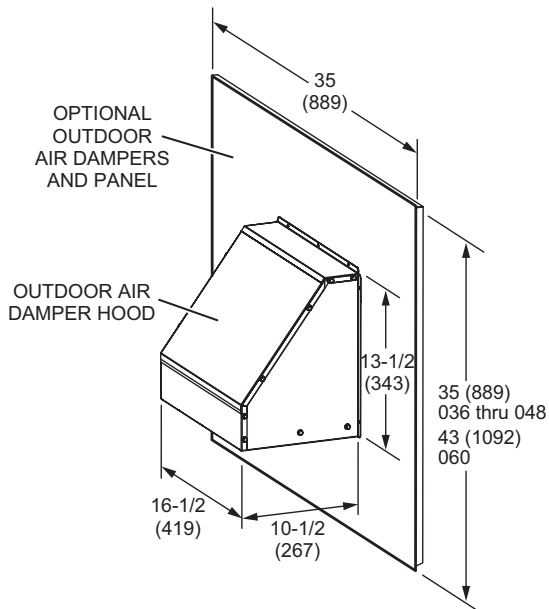
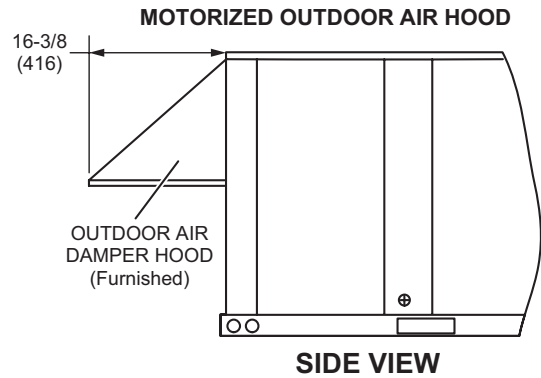
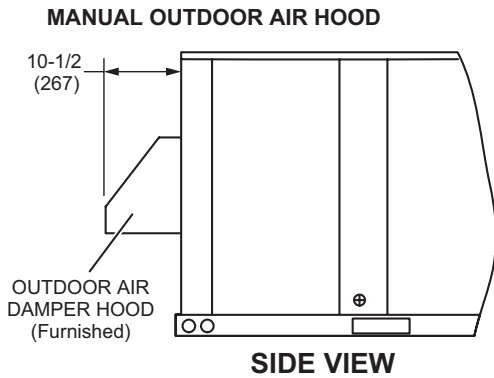

DIMENSIONS - ACCESSORIES

OUTDOOR AIR HOOD DETAIL WITH OPTIONAL ECONOMIZER AND OPTIONAL BAROMETRIC RELIEF DAMPERS WITH HOOD (Horizontal Application)

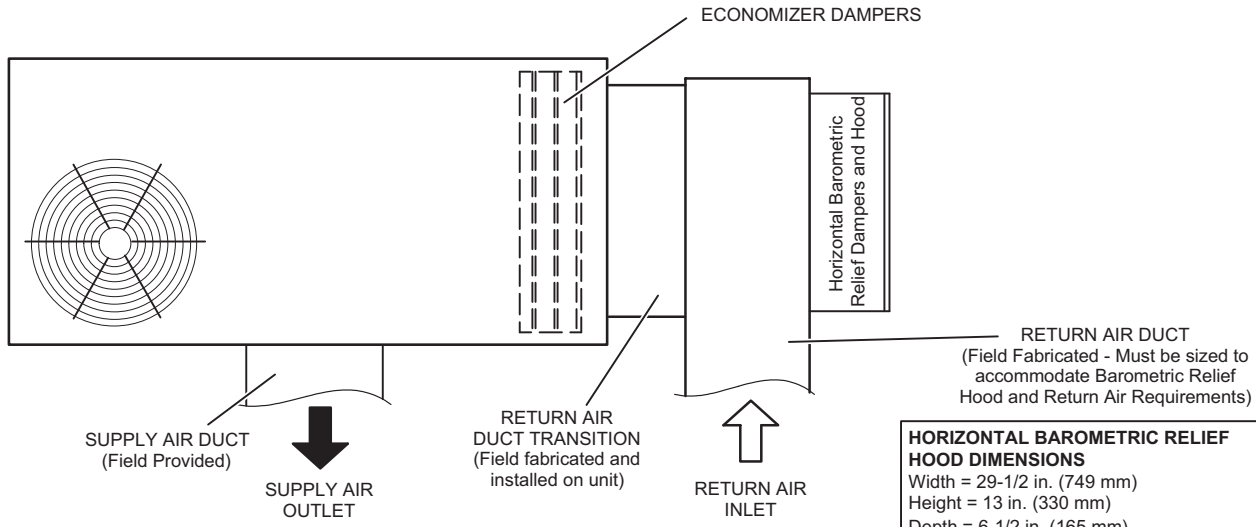

TOP VIEW

HORIZONTAL BAROMETRIC RELIEF HOOD DIMENSIONS
 Width = 29-1/2 in. (749 mm)
 Height = 13 in. (330 mm)
 Depth = 6-1/2 in. (165 mm)

NOTE - Horizontal applications with Economizer require Horizontal Economizer Conversion Kit. See Options/Accessories table.

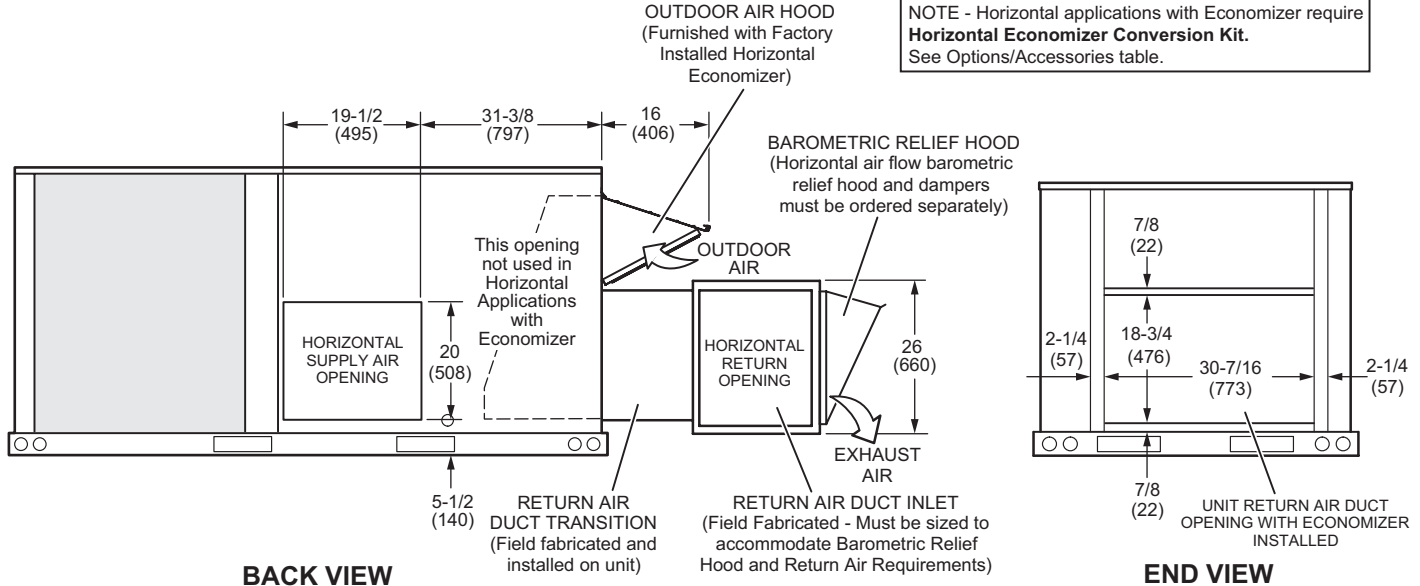

BACK VIEW

END VIEW

NOTE - Return Air Duct and Transition must be supported

HYBRID ROOF CURBS - DOUBLE DUCT OPENING

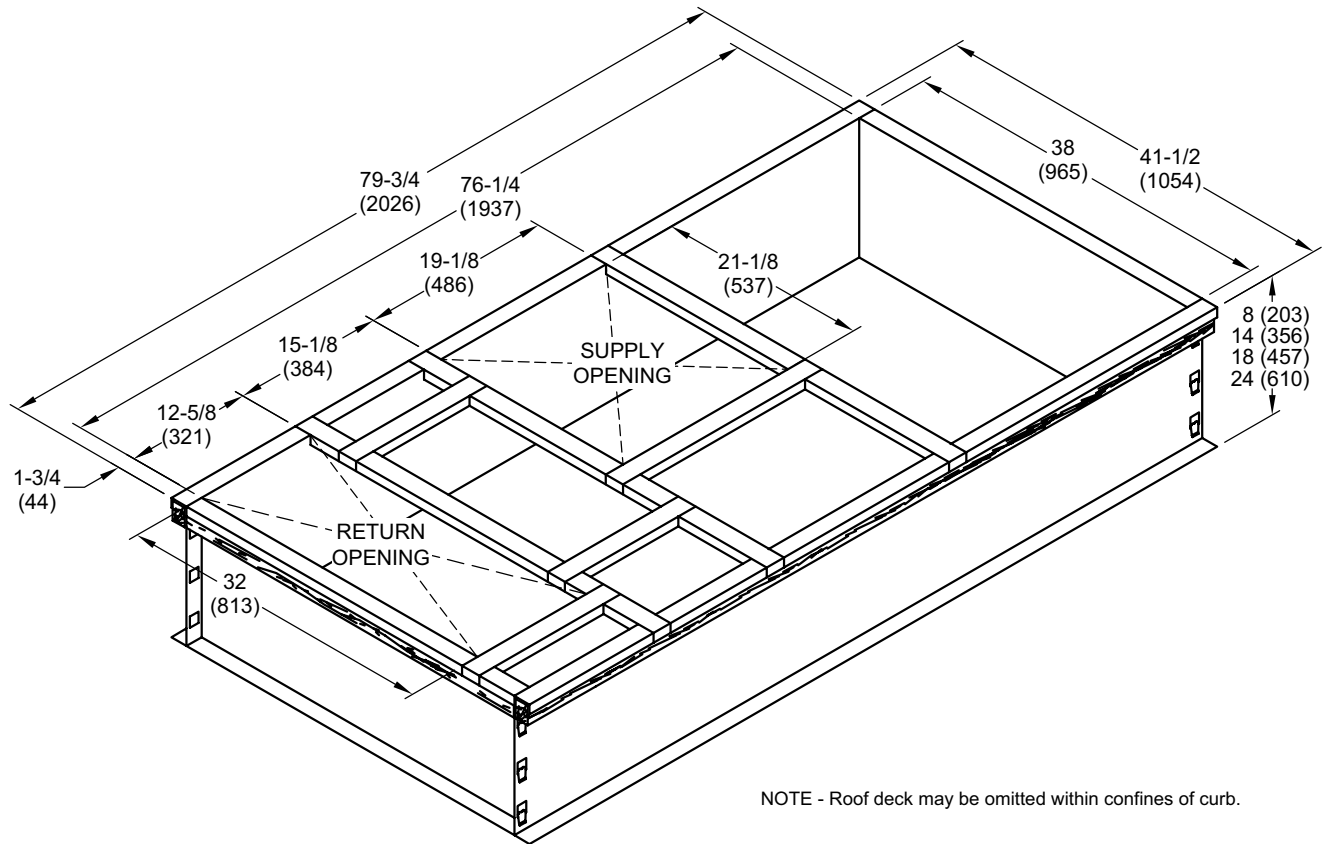

TYPICAL FLASHING DETAIL FOR ROOF CURB

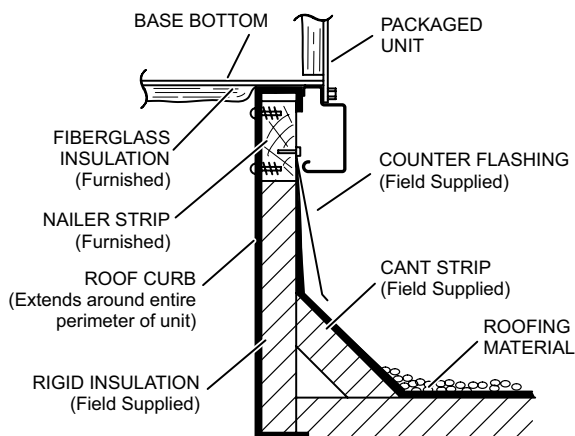

DETAIL ROOF CURB

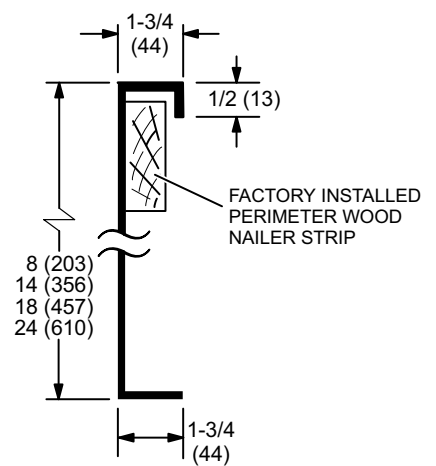

ADJUSTABLE PITCH CURBS - DOUBLE DUCT OPENING

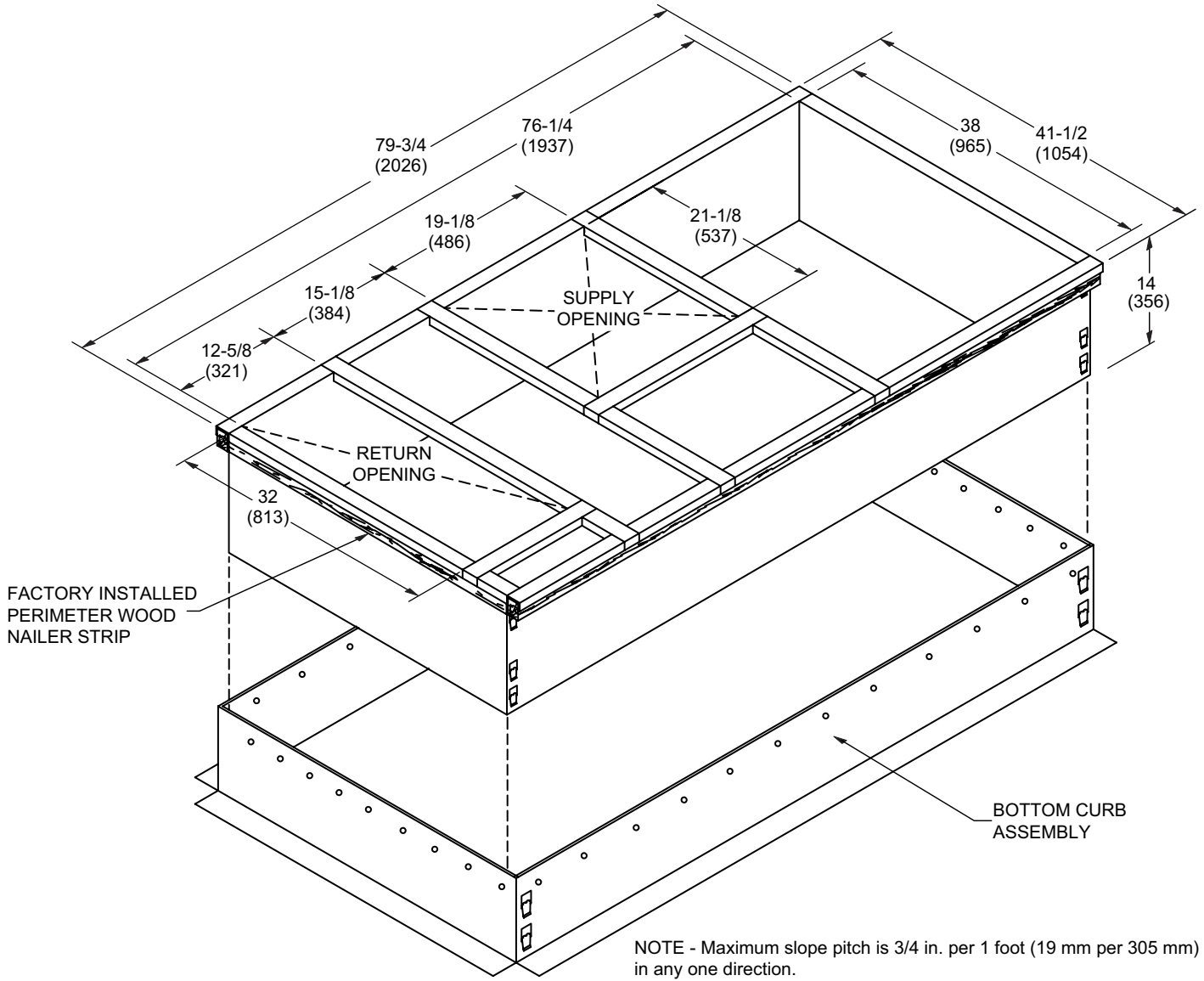

TYPICAL FLASHING DETAIL FOR ROOF CURB

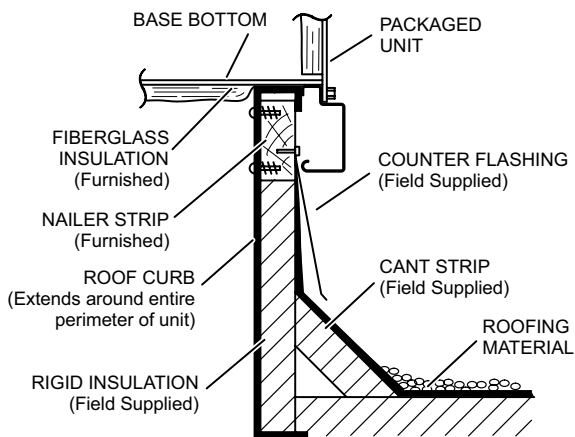

DETAIL ROOF CURB

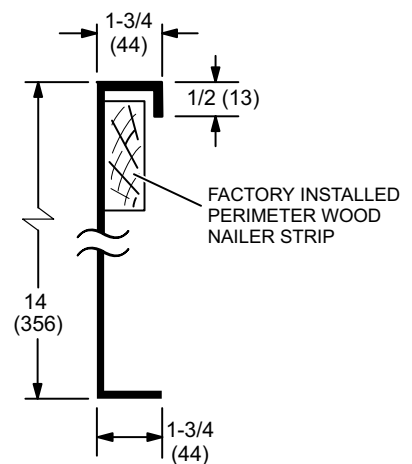

TRANSITIONS

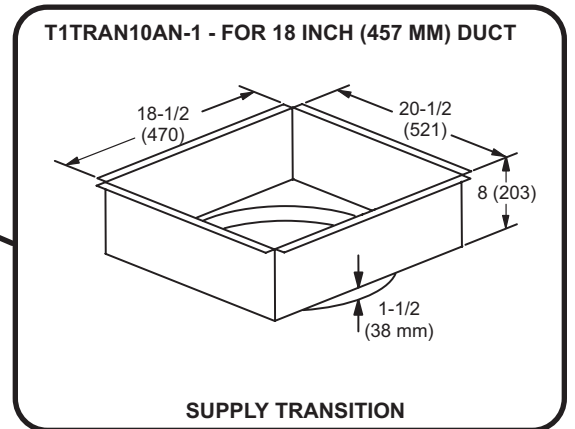
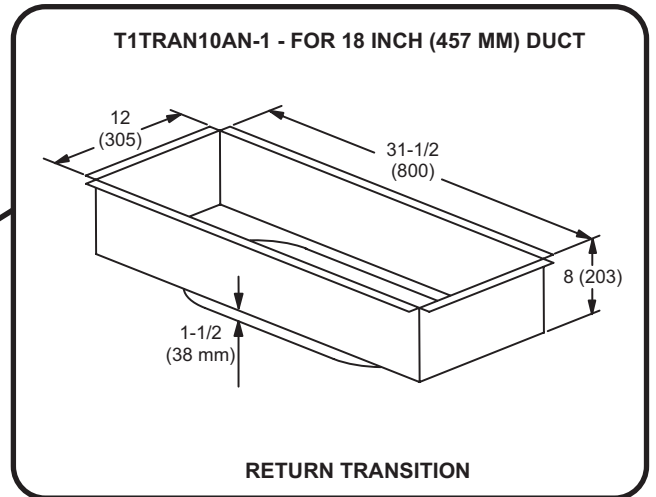
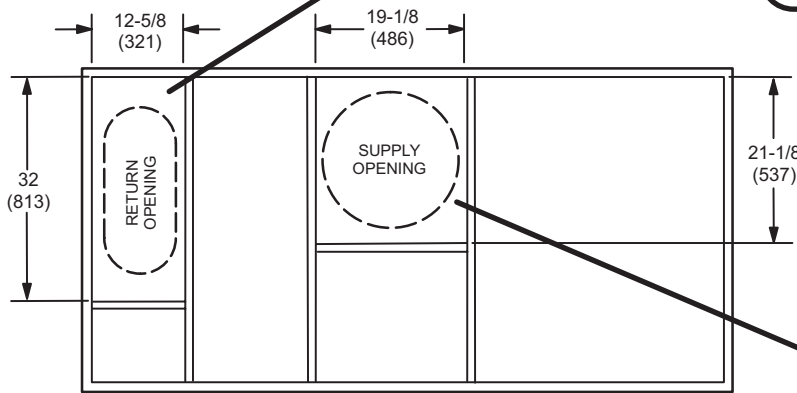

DIMENSIONS - ACCESSORIES

COMBINATION CEILING SUPPLY AND RETURN DIFFUSERS

STEP-DOWN CEILING DIFFUSER

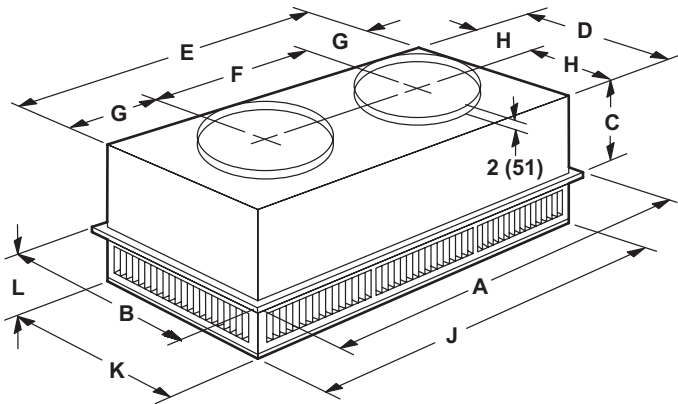

FLUSH CEILING DIFFUSER

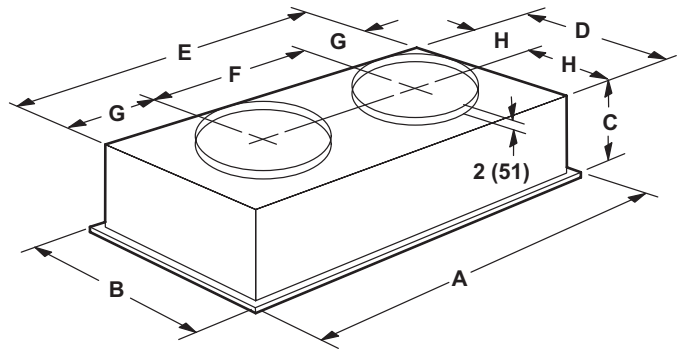

Model Number		RTD9-65S
A	in.	47-5/8
	mm	1159
B	in.	23-5/8
	mm	600
C	in.	11-3/8
	mm	289
D	in.	21-1/2
	mm	546
E	in.	45-1/2
	mm	1156
F	in.	22-1/2
	mm	572
G	in.	11-1/2
	mm	292
H	in.	10-3/4
	mm	273
J	in.	45-1/2
	mm	1156
K	in.	21-1/2
	mm	546
L	in.	7-1/8
	mm	181
Duct Size	in.	18 round
	mm	457 round

Model Number		FD9-65S
A	in.	47-5/8
	mm	1159
B	in.	23-5/8
	mm	600
C	in.	13-1/2
	mm	343
D	in.	21
	mm	533
E	in.	45
	mm	1143
F	in.	22-1/2
	mm	572
G	in.	11-1/4
	mm	286
H	in.	10-1/2
	mm	267
Duct Size	in.	18 round
	mm	457 round

REVISIONS

Sections	Description of Change
Options/Accessories	<p>Added step-down transformers for UVC lights.</p> <p>Catalog numbers revised for:</p> <ul style="list-style-type: none"> Barometric Relief Dampers Blower Proving Switch Cold Weather Kits Condensate Drain Trap Disconnects Drain Pan Overflow Switch Economizers Fresh Air Tempering LPG Kits Power Exhaust Single Enthalpy Smoke Detectors



Intertek



Visit us at www.lennox.com

For the latest technical information, www.lennoxcommercial.com

Contact us at 1-800-4-LENNOX

NOTE - Due to Lennox' ongoing commitment to quality, Specifications, Ratings and Dimensions subject to change without notice and without incurring liability. Improper installation, adjustment, alteration, service or maintenance can cause property damage or personal injury. Installation and service must be performed by a qualified installer and servicing agency.

©2021 Lennox Industries, Inc.