

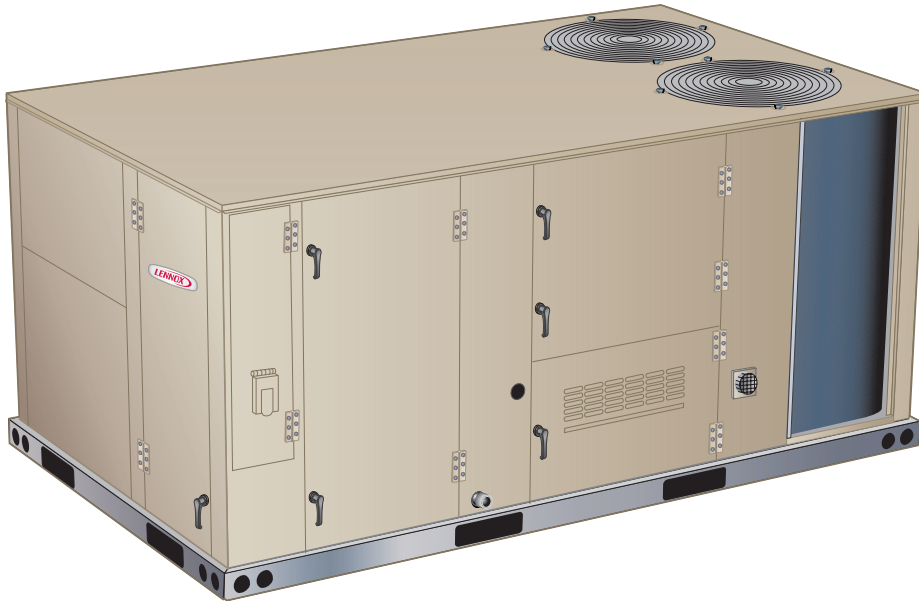

**LGM**  
 Model L™ Ultra-High Efficiency Rooftop Units  
 60 Hz

**COMMERCIAL  
 PRODUCT SPECIFICATIONS**

Bulletin No. 210936  
 August 2021  
 Supersedes June 2021



SMARTWIRE™ SYSTEM



**ASHRAE 90.1  
 COMPLIANT**

**7.5 to 12.5 Tons**  
**Net Cooling Capacity - 86,000 to 138,000 Btuh**  
**Gas Input Heat Capacity - 130,000 to 240,000 Btuh**

**MODEL NUMBER IDENTIFICATION**

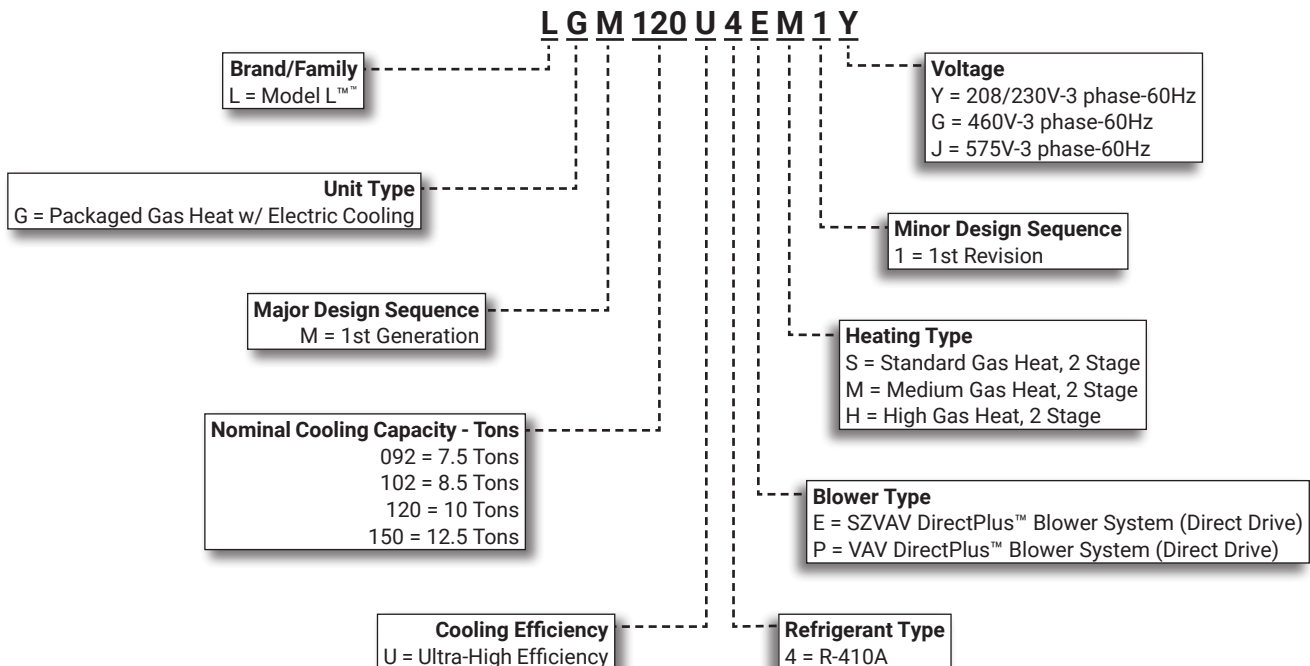

## FEATURE HIGHLIGHTS

The Model L™ packaged rooftop line is engineered with advanced variable speed technology to offer some of the highest energy efficiencies in the industry while delivering superior temperature and humidity control in a wide variety of commercial applications.

1. Heat Exchanger/Inshot Burners
2. Variable Capacity Scroll Compressor and Fixed Capacity Scroll Compressor
3. Condenser Coil
4. Variable-Speed ECM Outdoor Coil Fan Motors
5. Heavy Gauge Steel Cabinet
6. Hinged Access Panels
7. DirectPlus™ Direct Drive ECM Blower System
8. Air Filters
9. Lennox® CORE Control System
10. Humiditrol™+ Dehumidification System (option)

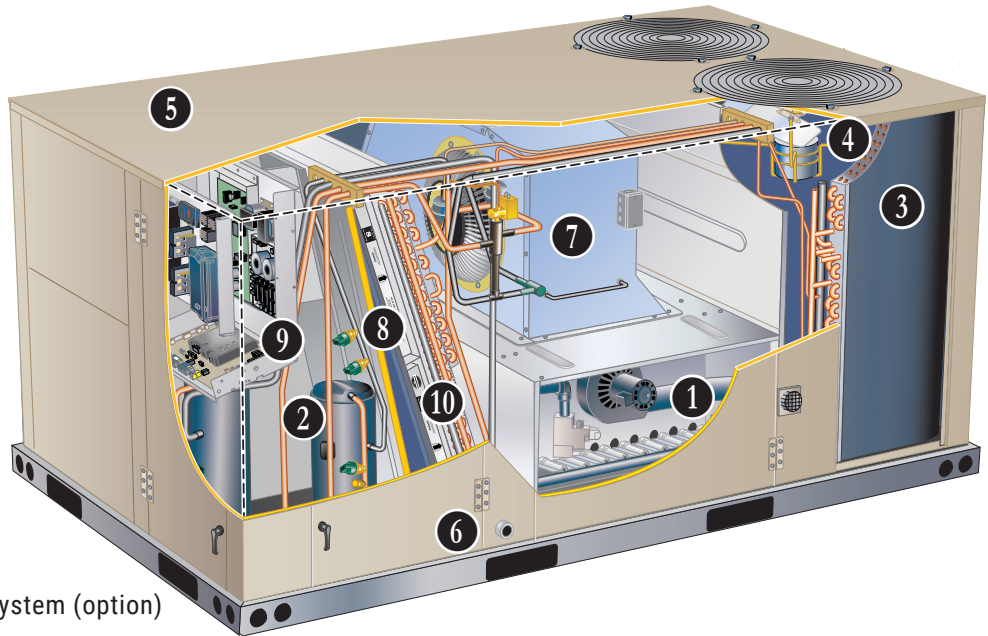

## CONTENTS

Approvals And Warranty . . . . .	3
Blower Data . . . . .	26
Control System . . . . .	8
Cooling Ratings . . . . .	23
Dimensions . . . . .	33
- Unit . . . . .	33
- Accessories . . . . .	34
Electrical Data . . . . .	29
- 7.5 Ton . . . . .	29
- 8.5 Ton . . . . .	29
- 10 Ton . . . . .	30
- 12.5 Ton . . . . .	30
Features And Benefits . . . . .	3
High Altitude Derate . . . . .	22
Humiditrol™+ Dehumidification System Option . . . . .	12
Humiditrol™+ Dehumidification System Ratings . . . . .	25
Model Number Identification. . . . .	1
Optional Conventional Temperature Control Systems . . . . .	13
Options / Accessories . . . . .	18
Outdoor Sound Data . . . . .	31
Sequence Of Operation. . . . .	15
Specifications . . . . .	21
- Unit . . . . .	21
- Gas Heat . . . . .	22
Unit Clearances . . . . .	31
Weight Data . . . . .	32
- Unit . . . . .	32
- Options / Accessories. . . . .	32

## APPROVALS AND WARRANTY

### **APPROVALS**

- AHRI Standard 340/360 certified
- ETL and CSA listed
- CSA certified energy ratings
- Unit and components ETL, NEC, and CEC bonded for grounding to meet safety standards for servicing
- All models are ASHRAE 90.1-2010 energy efficiency compliant and meet or exceed requirements of Section 6.8
- All models meet DOE 2018 and 2023 energy efficiency standards
- All models meet California Code of Regulations, Title 24 and ASHRAE 90.1-2016 Section 6.4.3.10 requirements for staged airflow
- All models have OSHPD OSP and Special Seismic Certification ([OSHPD Number: OSP-0596](#)), and meet 2018 International Building Code (IBC), 2019 California Building Code (CBC), ASCE 7, and ICC-ES AC156
- ENERGY STAR® certified
- ISO 9001 Registered Manufacturing Quality System

### **WARRANTY**

- Aluminized Steel Heat Exchanger - Limited ten years
- Optional Stainless Steel Heat Exchanger - Limited fifteen years
- Compressor - Limited five years
- Lennox® CORE Unit Controller - Limited three years
- Optional High Performance Economizers - Limited five years
- All other covered components - Limited one year

## FEATURES AND BENEFITS

### **HEATING SYSTEM**

- 1 • Aluminized steel inshot burners
- Direct spark ignition
- Electronic flame sensor
- Combustion air inducer
- Redundant automatic dual stage gas valve with manual shut-off

#### **Heat Exchanger**

- Tubular construction, aluminized steel
- Life-cycle tested

**NOTE** - Optional Stainless Steel Heat Exchanger is required if mixed air temperature is below 45°F.

#### **Electronic Pilot Ignition**

- Electronic spark igniter provides positive direct ignition of burners on each operating cycle
- Permits main gas valve to stay open only when the burners are proven to be lit
- If loss of flame occurs, gas valve closes, shutting off the gas to the burners
- LED indicates status and aids in troubleshooting
- Watchguard circuit on module automatically resets ignition controls after one hour of continuous thermostat demand after unit lockout, eliminating nuisance service calls
- Factory installed in the gas heating compartment

#### **Limit Controls**

- Redundant limit controls with fixed temperature setting
- Protects heat exchanger and other components from overheating

#### **Safety Switches**

- Flame roll-out switch
- Flame sensor
- Combustion air inducer proving switch
- Protects system operation

#### **Required Selections**

##### **Gas Input Choice - Order one:**

- Standard Gas Heat, 2 Stage (84,500/130,000 Btuh)
- Medium Gas Heat, 2 Stage (117,000/180,000 Btuh)
- High Gas Heat, 2 Stage (156,000/240,000 Btuh)

#### **Options/Accessories**

##### **Factory Installed**

###### **Stainless Steel Heat Exchanger**

- Required if mixed air temperature is below 45°F

##### **Factory or Field Installed**

###### **Bottom Gas Piping Kit**

- Allows bottom gas entry
- Factory installed kit is furnished with the unit for field installation

##### **Low Temperature Vestibule Heater**

- Electric heater automatically controls minimum temperature in gas burner compartment when temperature is below -40°F
- CSA certified to allow operation of unit down to -60°F

## FEATURES AND BENEFITS

### HEATING SYSTEM (continued)

#### Options/Accessories (continued)

##### Field Installed

##### Combustion Air Intake Extensions

- Recommended for use with existing flue extension kits in areas where high snow areas can block intake air

##### LPG/Propane Kits

- Conversion kit to field change over units from Natural Gas to LPG/Propane

##### Vertical Vent Extension Kit

- Use to exhaust flue gases vertically above unit
- Required when unit vent is too close to fresh air intakes per building codes
- Also prevents ice formation on intake louvers
- Kit contains vent transition, vent tee, drain cap and installation hardware

**NOTE** - Straight vent pipes (4 in. B-Vent) and caps are not furnished and must be field supplied. Refer to kit instructions for additional information.

### COOLING SYSTEM

- Designed to maximize sensible and latent cooling performance at design conditions
- System can operate from 0°F to 125°F without any additional controls

##### R-410A Refrigerant

- Non-chlorine based
- Ozone-friendly

#### 2 Dual Compressors

Cooling system consists of one variable capacity scroll compressor and one fixed capacity scroll compressor

##### Variable Capacity Scroll Compressor

- High performance, reliability and quiet operation
- Operates on a variable frequency determined to vary capacity based on the cooling load required

##### Fixed Capacity Scroll Compressor

- High performance, reliability and quiet operation
- Resiliently mounted on rubber grommets for quiet operation

##### Compressor Crankcase Heaters

- Protects against refrigerant migration that can occur during low ambient operation or during extended off cycles

##### DC Inverter Control (for Variable Capacity Compressor)

- Converts AC line voltage into filtered variable DC voltage
- Provides continuous compressor operation, while adjusting the capacity according to discharge air temperature
- Adjusts compressor output in increments as small as 1%
- Prevents frequent changes in capacity and ensures efficient, economical operation
- Power Factor Correction (PFC) circuit monitors the DC bus for high, low and abnormal voltage conditions to protect the compressor

- Two LEDs (red and green) indicate inverter operating status and aid in troubleshooting
- Noise filter reduces unwanted electromagnetic interference (EMI)
- Inverter reactor adds inductance to the line between the inverter and the compressor to limit current rise and protect the compressor

##### Thermal Expansion Valves

- Ensures optimal performance throughout the application range
- Removable element head

##### Filter/Driers

- High capacity filter/drier protects the system from dirt and moisture

##### High Pressure Switches

- Protects the system from high pressure conditions

##### Low Pressure Switches

- Protects the compressors from low pressure conditions such as low refrigerant charge, or low/no airflow

##### Diagnostic and Sensor System

- Multiple thermistors continuously monitor the refrigeration system, providing optimum performance and complete circuit protection at all operating conditions

##### Indoor Coil Freeze Protection

- Protects the evaporator coil from damaging ice build-up due to conditions such as low/no airflow, or low refrigerant charge

#### 3 Condenser Coil

- Copper tube construction
- Enhanced rippled-edge aluminum fins
- Flared shoulder tubing connections
- Silver soldered construction

##### Evaporator Coil

- Copper tube construction
- Enhanced rippled-edge aluminum fins
- Flared shoulder tubing connections
- Silver soldered construction
- Cross row circuiting with rifled copper tubing

##### Anti-Microbial Condensate Drain Pan

- Plastic pan, sloped to meet drainage requirements per ASHRAE 62.1
- Anti-Microbial additive resists growth of mold and mildew on drain pan, which improves indoor air quality and reduces drain line blockage
- Side or bottom drain connections
- Reversible to allow connection at back of unit

##### Outdoor Coil Fans

- PVC coated fan guard furnished

## FEATURES AND BENEFITS

### **COOLING SYSTEM (continued)**

- 4** Variable-Speed ECM Outdoor Coil Fan Motors
- Fan speed is directly controlled by the Lennox® CORE Unit Controller
  - Thermal overload protected
  - Totally enclosed
  - Permanently lubricated ball bearings
  - Shaft up
  - Wire basket mount

#### Options/Accessories

#### **Factory Installed**

##### Service Valves

- Fully serviceable brass valves installed in discharge & liquid lines

**NOTE** - Not available for units equipped with Humiditrol™+ Dehumidification option.

#### **Factory or Field Installed**

##### Condensate Drain Trap

- Constructed of PVC (factory or field) or copper (field only)

**NOTE** - Trap is field installed only; PVC version may be factory ordered to ship with unit.

##### Drain Pan Overflow Switch

- Monitors condensate level in drain pan
- Shuts down unit if drain becomes clogged

### **CABINET**

- 5** Construction
- Heavy-gauge steel panels
  - Full perimeter heavy-gauge galvanized steel base rail
  - Base rails have rigging holes
  - Three sides of the base rail have forklift slots
  - Raised edges around duct and power entry openings in the bottom of the unit for water protection

##### Airflow Choice

- Units are shipped in downflow (vertical) configuration

**NOTE** - Units can be field converted to horizontal airflow with optional Horizontal Discharge Kit.

##### Duct Flanges

- Provided for horizontal duct attachment

##### Power Entry

- Electrical lines can be brought through the unit base or through horizontal access knock-outs

##### Exterior Panels

- Constructed of heavy-gauge, galvanized steel
- Textured pre-paint with polyurethane finish
- Cyclic salt fog and UV exposure up to 1680 hours per ASTM D5894

##### Insulation

- Fully insulated with non-hygroscopic fiberglass insulation (conditioned areas)

- Unit base is fully insulated
- Base insulation serves as an air seal to the roof curb, eliminating the need to add a seal during installation

**6** Hinged Access Panels

- Tool-less access
- Filter section
- Blower/heating section
- Compressor/controls section
- Panel seals and quarter-turn latching handles provide a tight air and water seal

#### Required Selections

##### Airflow Configuration

- Specify downflow or horizontal

#### Options/Accessories

#### **Factory or Field Installed**

##### Return Air Adaptor Plate

- For same size LC/LG/LH and TC/TG/TH unit replacement
- Installs on return air opening in unit to match return air opening on existing roof curbs
- Also see Accessory Air Resistance table

#### **Factory Installed**

##### Corrosion Protection

- Completely flexible immersed coating
- Electrodeposited dry film process
- AST ElectroFin E-Coat
- Meets Mil Spec MIL-P-53084, ASTM B117 Standard Method Salt Spray Testing
- Indoor Corrosion Protection:
  - Coated coil
  - Coated reheat coil (Humiditrol™+)
  - Painted blower housing
  - Painted base
- Outdoor Corrosion Protection:
  - Coated coil
  - Painted outdoor base

#### **Field Installed**

##### Combination Coil/Hail Guards

- Heavy gauge steel frame
- Painted to match cabinet
- Expanded metal mesh protects outdoor coil

##### Horizontal Discharge Kit

- Consists of duct covers to block off downflow supply and return air openings for horizontal applications
- Also includes return air duct flanges for end return air when Economizer is used in horizontal applications

**NOTE** - When configuring unit for horizontal application with Economizer, a separate Horizontal Barometric Relief Damper with Hood must be ordered separately for installation in the return air duct.

## FEATURES AND BENEFITS

### **BLOWER**

#### **7 DirectPlus™ Direct Drive ECM Blower System**

- High-efficiency, variable-speed ECM (electronically commutated) motor
- Eliminates the need for a separate variable-frequency drive
- SZVAV equipped models modulate the amount of supply blower airflow according to cooling demand, heating demand, ventilation demand or smoke alarm
- The amount of airflow for each stage can be set according to a parameter in the Lennox® CORE Unit Controller
- Unit is shipped from the factory with preset airflows
- Fully variable speed motor modulates to maximize system efficiency
- Combines the motor and electronics into one unit
- Aerodynamically optimized impeller
- Backward curved blades mounted directly onto the rotor



• Air inlet grill reduces indoor sound levels without affecting air performance



#### **Supply Static Pressure Transducer (VAV Models Only)**

- Sends information to the Lennox® CORE Unit Controller to control blower speed to the desired supply duct static pressure
- Shipped with the unit for remote field installation in the supply duct

### **Required Selections**

#### **Blower Selection**

- SZVAV (Single Zone Variable Air Volume) controls the speed of the blower based on the cooling and heating demands
- VAV (Variable Air Volume) blower varies the air volume to maintain a constant supply duct static pressure

### **ELECTRICAL**

#### **SmartWire™ System**

- Keyed and color-coded wiring connectors prevent miswiring
- Wire coloring scheme is standardized across all models
- Each connection is intuitively labeled to make troubleshooting and servicing quick and easy

#### **Electrical Plugs**

- Positive connection electrical plugs are used to connect common accessories or maintenance parts for easy removal or installation

#### **Phase/Voltage Detection**

- Monitors power supply to ensure phase is correct at unit start-up
- If phase is incorrect, the unit will not start and an alarm code is reported to the unit controller
- Protects unit from being started with incorrect phasing which could lead to issues such as compressors running backwards
- Voltage detection monitors power supply voltage to ensure proper voltage
- If voltage is not correct (over/under voltage conditions) the unit will not start and an alarm code is reported to the unit controller

### **Required Selections**

#### **Voltage Choice**

- Specify when ordering base unit

### **Options/Accessories**

#### **Factory Installed**

##### **Circuit Breakers**

- HACR type
- For overload and short circuit protection
- Factory wired and mounted in the power entry panel
- Current sensitive and temperature activated
- Manual reset

##### **Short-Circuit Current Rating (SCCR)**

- Higher short circuit protection up to 100kA

**NOTE** - Disconnect Switch is furnished and factory installed with High SCCR option.

#### **Factory or Field Installed**

##### **Disconnect Switch**

- Accessible outside of unit
- Spring loaded weatherproof cover furnished

##### **GFI Service Outlets (2)**

- 115V ground fault circuit interrupter (GFCI) type
- Non-powered, field-wired

#### **Field Installed**

##### **GFI Weatherproof Cover**

- Single-gang cover
- Heavy-duty UV-resistant polycarbonate case construction
- Hinged base cover with gasket

## FEATURES AND BENEFITS

### INDOOR AIR QUALITY

#### 8 Air Filters

- Disposable 2-inch filters furnished as standard

#### Options/Accessories

#### Factory or Field Installed

##### Healthy Climate® High Efficiency Air Filters

- Disposable MERV 8, MERV 13 or MERV 16 (Minimum Efficiency Reporting Value based on ASHRAE 52.2) efficiency 2-inch pleated filters

##### Healthy Climate® UVC Germicidal Lamps

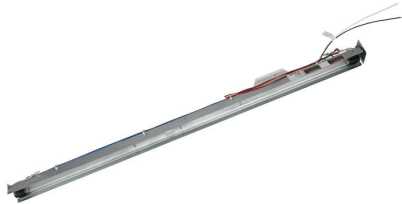

- Germicidal lamps emit ultra-violet (UV-C) energy, which has been proven to be effective in reducing microbes such as viruses, bacteria, yeasts, and molds
- This process either destroys the organism or controls its ability to reproduce
- UV-C energy greatly reduces the growth and proliferation of mold and other bioaerosols (bacteria and viruses) on illuminated surfaces (particularly coil and drain pan)
- Installed in the blower/evaporator coil section
- Safety interlock switch automatically shuts off power to the UVC light when panel is removed
- Interlock switch is factory installed or field installed in the blower/evaporator coil section panel
- All necessary hardware for installation is included
- Lamps operate on 110/230V, 1 phase power supply

**NOTE** - For 460V and 575V units, field installed lamps utilize jumpers to the outdoor fan transformer for voltage needed. See the installation Instructions.

- Approved by ETL

##### Needlepoint Bipolar Ionization (NPBI) Kit

- NPBI technology integrates with system controls for effective air treatment
- Ionization has been shown to effectively reduce harmful pathogens, pollutants and odors

**NOTE** - Please visit [www.sciencedirect.com](http://www.sciencedirect.com) for additional information.

- Brush-type ionizer introduces a high concentration of both positive and negative ions into the airstream
- These bipolar ions are then dispersed into the occupied space through the duct system proactively reducing the airborne contaminants
- Ions travel within the building air stream and attach to particles, pathogens, and gas molecules, making them larger and easier to capture in the filtration system
- UL 2998 certified for zero ozone emission

#### Field Installed

##### Indoor Air Quality (CO<sub>2</sub>) Sensors

- Monitors CO<sub>2</sub> levels, reports to the Lennox® CORE Unit Controller which adjusts Economizer dampers as needed

##### Replacement Filter Media Kit With Frame

- Replaces existing pleated filter media
- Includes washable metal mesh screen and metal frame with clip for holding replaceable non-pleated filter

## CONTROL SYSTEM

### LENNOX® CORE CONTROL SYSTEM

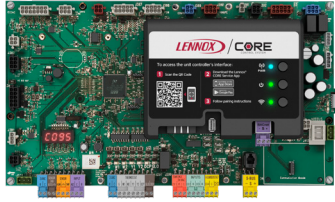

The Lennox® CORE Control System is designed to accelerate equipment install and service. Standard with all Model L™ rooftop units, control system integrates key technologies that lower installation costs, drive system efficiency, and protect your investments.

9 The Lennox® CORE Unit Controller is a microprocessor-based controller that provides flexible control of all unit functions.

#### Wireless Service App Connectivity (Coming Soon to Android and iOS)

- Setup menu ensures proper installation and simplified setup of the rooftop unit
- Detailed data readout updates sensor values in real time and allows trending
- Unit self-test verifies individual critical component and system performance
- Economizer test function ensures Economizer is operating correctly

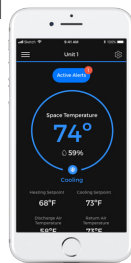

**NOTE** - Android or iOS device required.

#### Additional Features:

- Built-In 7-Segment Display shows Unit Status and active alarms for easy troubleshooting
- Buttons for test and clearing delays
- SmartWire™ System with keyed and removable screw terminals ensure correct field wiring
- Built-in BACnet MS/TP and IP allow open integration to building management systems.
- Two-port Ethernet Switch enables daisy chaining for BACnet IP and automatic firmware updates

**NOTE** - Unit Internet Connection required.

- Profile setup copies key settings between units with the same configuration to reduce setup time
- USB port allows a technician to download and transfer unit information to help verify service was performed
- USB software updates on the Lennox® CORE Unit Controller enhance functionality without the need to change components
- Unit Controller Software

#### Configurable Built-In Functions

- Full modulation of variable speed compressor for discharge air temperature control in room sensor or thermostat mode
- Discharge Air Cooling Control (Standard)
- Up to three distinct Cooling Airflows in Thermostat Mode with additional relay
- Programmable independent heating, ventilation and cooling blower speeds

- Discharge Air Heating Control
- Economizer Control Options (See Economizer / Exhaust Air / Outdoor Air sections)
- Exhaust Fan Control Modes for fresh air damper position
- Configurable Morning Warm-up
- Night Setback Mode
- Fresh Air Tempering for Improved Ventilation
- Demand Control Ventilation
- Low Ambient Controls for operation down to 0°F
- Humiditrol™+ Operation (Variable Capacity Hot-Gas Reheat)
- Enhanced Dehumidification (Latent Demand Control without reheat)

#### Component Protection / Unit Safeguards:

- Compressor Time-Off Delay
- Adjustable Blower On/Off Delay
- Return Air Temperature Limit Control
- Safety Switch Input allows Controller to respond to a external safety switch trip
- Service Relay Output
- Thermostat Bounce Delay
- Smoke Alarm Mode has four choices (unit off, positive pressure, negative pressure, purge)
- "Strike Three" Protection
- Gas Valve Time Delay Between First and Second Stage
- Minimum Compressor Run Time

#### Control Methods / Interfaces:

- DDC and 24V Thermostat
- BACnet MS/TP and IP
- LONTalk (Factory and Field Option)
- Lennox SBUS
- Compatibility with Lennox Wireless Room Sensors
- Zone Temperature Sensor Input
- Dehumidistat and Humidity Sensor Inputs
- Indoor Air Quality Inputs (2)
- Built-in Control Parameter Defaults
- Permanent Diagnostic Code Storage
- Field Adjustable Control Parameters (Over 200 settings)
- Multiple Configurable Digital Inputs
- LED Indicators
- PC Interface connects the Lennox® CORE Unit Controller to a PC with the Lennox Unit Controller Software

**NOTE** - Lennox® CORE Control System features vary with the type of rooftop unit in which the control is installed.



## CONTROL SYSTEM

### LENNOX® CORE CONTROL SYSTEM (continued)

#### Controls Options

##### Factory or Field Installed

##### Blower Proving Switch

- Monitors blower operation, shuts down unit if blower fails

##### Dirty Filter Switch

- Senses static pressure increase and issues alarm if necessary

##### Fresh Air Tempering

- Used in applications with high outside air requirements
- Controller energizes the first stage heat as needed to maintain a minimum supply air temperature for comfort, regardless of the thermostat demand
- When ordered as a factory option, sensor ships with the unit for field installation

##### Smoke Detector

- Photoelectric type
- Installed in supply air section, return air section or both sections
- Available with power board and single sensor (supply or return) or power board and two sensors (supply and return)
- Power board located in unit control compartment

##### Interoperability via BACnet® or LonTalk® Protocols

- Communication compatible with third-party automation systems that support the BACnet Application Specific Controller device profile, LonMark® Space Comfort Controller functional profile, or LonMark Discharge Air Controller functional profile

### COMMERCIAL CONTROL SYSTEMS

#### (Field Installed)

##### L Connection® Network Control System

- Complete building automation control system for single or multi-zone applications
- Options include local interface, software for local or remote communication, and hardware for networking other control functions
- See L Connection Network Control System Product Specifications Bulletin for details

##### After-Market DDC

- Novar® Unit Controller and options

##### Thermostats

- Control system and thermostat options, see page 13
- After-Market unit controller options

## OPTIONS / ACCESSORIES

### ECONOMIZER

- Economizer operation is set and controlled by the Lennox® CORE Unit Controller
- Simple plug-in connections from Economizer to unit controller for easy installation
- All Model L™ rooftop units are equipped with factory installed CEC Title 24 approved sensors for outside, return and discharge air temperature monitoring

**NOTE** - Optional sensors may be used instead of unit sensors to determine whether outdoor air is suitable for free cooling. See Options/Accessories table.

#### Factory or Field Installed

##### High Performance Economizer

- Approved for California Title 24 building standards
- Low leakage dampers are Air Movement and Control Association International (AMCA) Class 1A Certified - Maximum 3 CFM per sq. ft. leakage at 1 in. w.g.
- ASHRAE 90.1 and IECC compliant
- Downflow or Horizontal with Outdoor Air Hood
- Outdoor Air Hood is included when Economizer is factory installed and is furnished with Economizer when ordered for field installation
- Downflow Barometric Relief Dampers with Exhaust Hood is also furnished

**NOTE** - Horizontal economizer applications require optional Horizontal Low Profile Barometric Relief Dampers and Horizontal Discharge Kit.

- Gear-driven action
- High torque 24-volt fully-modulating spring return damper motor
- Return air and outdoor air dampers
- Plug-in connections to unit
- Stainless steel bearings
- Enhanced thermoplastic vulcanizate (TPV) seals
- Flexible stainless steel jamb seals

**NOTE** - High Performance Economizers are not approved for use with enthalpy controls in Title 24 applications.

**NOTE** - The Free Cooling setpoint for Title 24 applications must be set based on the Climate Zone where the system is installed. See Section 140.4 "Prescriptive Requirements for Space Conditioning Systems" of the California Energy Commission's 2019 Building Energy Efficiency Standards.

**NOTE** - Refer to Installation Instructions for complete setup information.

## OPTIONS / ACCESSORIES

### **ECONOMIZER (continued)**

#### **Factory or Field Installed (continued)**

##### **Differential Sensible Control**

- Factory setting
- Uses outdoor air and return air sensors that are furnished with the unit
- The Lennox® CORE Unit Controller compares outdoor air temperature with return air
- When the outdoor air is below the configured setpoint and cooler than return air, the controller activates the Economizer

**NOTE** - Differential Sensible Control can be configured in the field to provide Offset Differential Sensible Control or Single Sensible Control.

**NOTE** - In Offset Differential Sensible Control mode, the Economizer is enabled if the temperature differential (offset) between outdoor air and return air reaches the configured setpoint. In Single Sensible Control mode, the Economizer is enabled when outdoor air temperature falls below the configured setpoint.

##### **Global Control**

- The unit controller communicates with a DDC system with one global sensor (enthalpy or sensible)
- Determines whether outside air is suitable for free cooling on all units connected to the control system
- Sensor must be field provided

##### **Single Enthalpy Temperature Control (Not for Title 24)**

- Outdoor air enthalpy sensor enables Economizer if the outdoor enthalpy is less than the setpoint of the control

##### **Differential Enthalpy Control (Not for Title 24)**

- Order two Single Enthalpy Controls
- One is field installed in the return air section
- One is installed in the outdoor air section
- Allows the Economizer control to select between outdoor air or return air, whichever has lower enthalpy

### **Field Installed**

#### **Horizontal Low Profile Barometric Relief Dampers**

- For use when unit is configured for horizontal applications requiring an Economizer
- Allows relief of excess air
- Aluminum blade dampers prevent blow back and outdoor air infiltration during off cycle
- Field installed in return air duct
- Bird screen and hood furnished

**NOTE** - Requires Horizontal Discharge Kit.

### **Field Installed**

#### **Outdoor Air CFM Control**

- Maintains constant outdoor air volume levels on the supply air fan and varying unit airflows
- Velocity sensor located in the rooftop unit outdoor air section, the Lennox® CORE Unit Controller changes the Economizer position to help minimize the effect of supply fan speed changes on outdoor air volume levels
- Setpoint for outdoor air volume is established by field testing

**NOTE** - Not available with Demand Control Ventilation (CO<sub>2</sub> Sensor) or Building Pressure Control.

#### **Building Pressure Control**

- Maintains constant building pressure level
- Includes a static pressure transducer and outdoor static pressure assembly
- Using differential pressure information between the outdoor air and the building air, the Lennox® CORE Unit Controller changes the Economizer position to help maintain a constant building pressure

**NOTE** - Not available with Demand Control Ventilation (CO<sub>2</sub> Sensor) or Outdoor Air CFM Control.

### **POWER EXHAUST**

#### **Factory or Field Installed**

##### **Power Exhaust Fan**

- Installs internal to unit for downflow applications only with Economizer option
- Provides exhaust air pressure relief
- Interlocked to run when supply air blower is operating
- Fan runs when outdoor air dampers are 50% open (adjustable)
- Motor is overload protected
- Fan is 20 in. diameter
- Five blades
- One 1/3 hp motor

**NOTE** - Requires Economizer and Downflow Barometric Relief Dampers.

## OPTIONS / ACCESSORIES

### **OUTDOOR AIR OPTIONS**

#### **Factory or Field Installed**

##### **Outdoor Air Damper**

- Downflow or Horizontal
- Linked mechanical dampers
- 0 to 25% (fixed) outdoor air adjustable
- Installs in unit
- Includes outdoor air hood
- Automatic model features fully modulating spring return damper motor with plug-in connection
- Manual model features parallel blade, gear-driven dampers with adjustable fixed position

#### **ROOF CURBS**

##### **Field Installed**

- Nailer strip furnished (downflow only)
- Mates to unit
- US National Roofing Contractors Approved
- Shipped knocked down

##### **Hybrid Roof Curbs, Downflow**

- Interlocking tabs fasten corners together
- No tools required
- Can also be fastened together with furnished hardware
- Available in 8, 14, 18, and 24 inch heights

##### **Adjustable Pitch Curb**

- Fully adjustable pitch curbs (3/4 in. per foot in any direction) provide a level platform for rooftop units allowing flexible installations on roofs with uneven or sloped angles
- Interlocking tabs fasten corners together
- No tools required
- Hardware is furnished to connect upper curb with lower curb
- Available in 14 inch height

##### **Adaptor Curbs (not shown)**

- Curbs are regionally sourced
- Dimensions vary based upon the source

**NOTE** - Contact your local sales representative for a detailed cut sheet with applicable dimensions.

### **CEILING DIFFUSERS**

#### **Field Installed**

##### **Ceiling Diffusers (Flush or Step-Down)**

- White powder coat finish on diffuser face and grilles
- Insulated UL listed duct liner
- Diffuser box has collars for duct connection
- Step-down diffusers have double deflection blades
- Flush diffusers have fixed blades
- Provisions for suspending
- Internally sealed to prevent recirculation
- Removable return air grille
- Adapts to T-bar ceiling grids or plaster ceilings

##### **Transitions (Supply and Return)**

- Used with diffusers
- Installs in roof curb
- Galvanized steel construction
- Flanges furnished for duct connection to diffusers
- Fully insulated

## HUMIDITROL™ + DEHUMIDIFICATION SYSTEM OPTION

### OVERVIEW

- Factory installed option designed to control humidity
- 10 • Humiditrol™+ utilizes advanced control algorithms, variable speed technology and a reheat coil to efficiently control humidity levels independent of room temperature
- Provides dehumidification on demand using ASHRAE 90.1 recommended method for comfort conditioning humidity control
- Unit comes equipped with one row reheat coil and solenoid valve

**NOTE** - A dehumidification demand from a relative humidity sensor, dehumidistat, a DDC controller or building automation system is required to control humidity

### BENEFITS

- Improves indoor air quality
- Discharge air control for overcool protection
- Adjustable discharge air temperature setpoint
- Energy efficient dehumidification
- Modulating latent and sensible capacity
- Helps prevent damage due to high humidity levels
- Improves comfort levels by reducing space humidity levels

### OPERATION

#### No Dehumidification Demand

- The unit will operate conventionally whenever there is a demand for cooling or heating and no dehumidification demand
- Free cooling is only permitted when there is no demand for dehumidification

#### Dehumidification Demand Only

- Reheat operation will initiate on a dehumidification demand and does not require a cooling demand
- The unit will operate in hot gas reheat dehumidification mode until the relative humidity of the conditioned space is below the setpoint
- A solenoid valve diverts hot gas from the compressor to the reheat coil
- The cooled and dehumidified air from the evaporator is reheated as it passes through the reheat coil
- The de-superheated and partially condensed refrigerant continues to the outdoor condenser coil where condensing is completed
- Unit will continue to operate in this mode until the dehumidification demand is satisfied
- The reheat coil is sized to provide optimal reheat performance without overheating supply air
- The compressor will modulate based on dehumidification load
- The outdoor fans modulate speed to provide discharge air temperature control in reheat mode

#### Dehumidification and Cooling Demand (Thermostat/ Room Sensor Application)

- If both a dehumidification and a cooling demand occur, the system will operate in cooling until the cooling demand is satisfied
- Then the system will energize the dehumidification mode

**NOTE** - See Sequence of Operation for additional information.

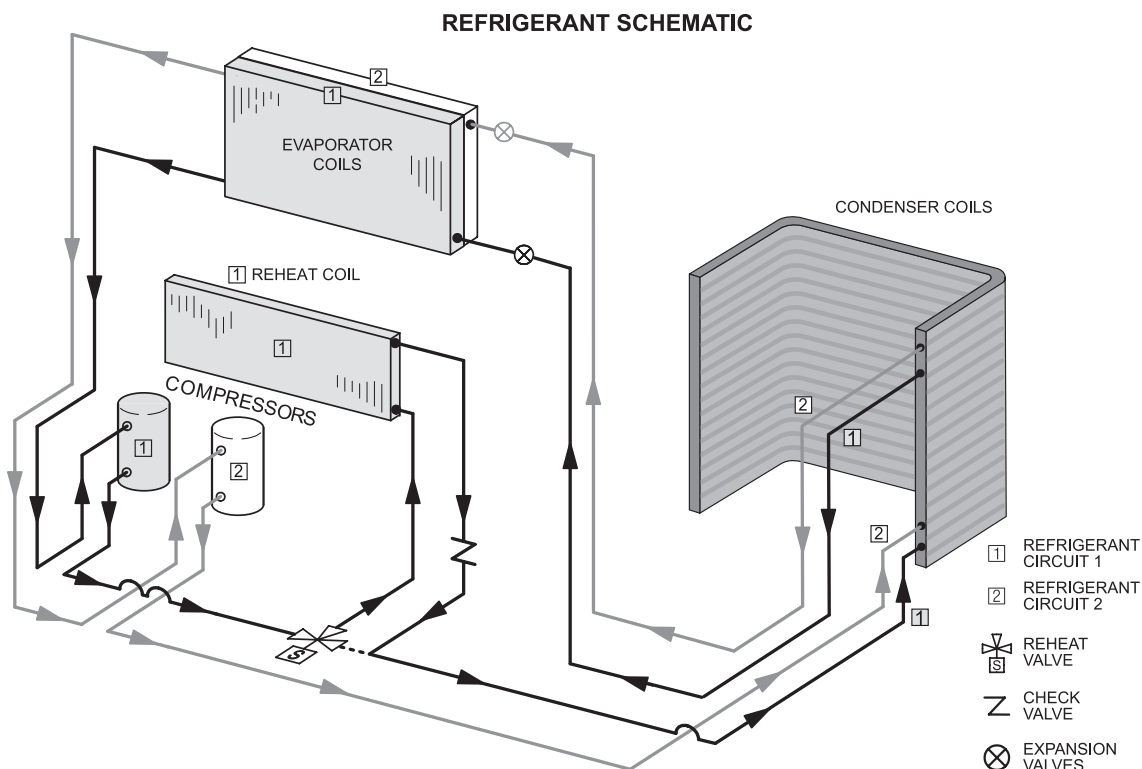

## OPTIONAL CONVENTIONAL TEMPERATURE CONTROL SYSTEMS

### ComfortSense® 8500 Commercial 7-Day Programmable Thermostat

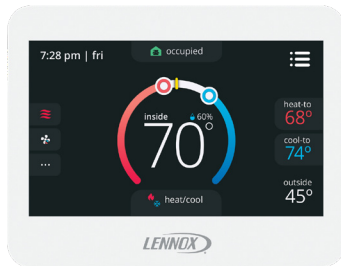

- Fully Communicating Sensor
- Full Color Touchscreen Interface
- Variable Speed System Control (On Compatible Units)
- Up To 4 Heat / 4 Cool
- Built-In Sensors For Temperature, Humidity And Optional CO<sub>2</sub>
- Remote Sensor Options For Occupancy, Temperature
- BACnet Capable Options
- 5-2 or 7-Day Scheduling
- Smooth Setback Recovery
- Heat/Cool Auto-Changeover
- Four-Wire Installation
- FDD, ASHRAE, IECC Compliant

### ComfortSense® 7500 Commercial 7-Day Programmable Thermostat



- Premium Universal Thermostat
- Full Color Touchscreen Interface
- Up To 4 Heat / 2 Cool
- Built-In Sensors For Temperature and Humidity
- Remote Sensors Options For Temperature, Discharge Air, Outdoor Air
- 5-2 or 7-Day Scheduling
- Smooth Setback Recovery
- Heat/Cool Auto-Changeover
- FDD, ASHRAE, IECC Compliant

### ComfortSense® 3000 Commercial 5-2 Day Programmable Thermostat

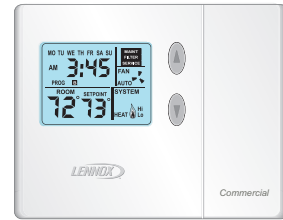

- Conventional Multi-Stage Thermostat
- Intuitive Display
- Push-Button Operation
- Up To 2 Heat / 2 Cool
- Built-In Temperature Sensor
- Remote Temperature Sensing
- Up to 5-2 Day Scheduling
- Smooth Setback Recovery
- Heat/Cool Auto-changeover

### Wireless/Wired Room Sensor (LCS-5030)



- Simple Push-Button Override
- Variable Speed System Control (On Compatible Units)
- Up To 4 Heat / 4 Cool
- Built-In Temperature and Humidity Sensors
- AA Battery / 24VAC Powered
- Bluetooth™ Mesh Operation
- SBUS Wired Operation
- Automatic Sensor Averaging
- Locking Hex Screw

### Wireless Repeater



- Extends Effective Range of Wireless Sensor
- 24VAC Only
- Locking Hex Screw

**NOTE** - Wireless only.

## OPTIONAL CONVENTIONAL TEMPERATURE CONTROL SYSTEMS

Description	Catalog No.
<b>ComfortSense® 8500 Commercial 7 Day Programmable Thermostat</b>	
CS8500 7-Day Thermostat	No CO <sub>2</sub> Sensing <b>17G75</b>
	With CO <sub>2</sub> Sensing <b>17G76</b>
Sensors/Accessories	<sup>1</sup> Remote non-adjustable wall-mount 10k <b>47W37</b>
	<sup>1</sup> Remote non-adjustable wall-mount 11k <b>94L61</b>
<b>Sysbus Network Cable (Yellow) for ComfortSense 8500 and LCS-5030 Wired Room Sensor</b>	
Twisted pair 100% shielded communication cable, Red and Black	500 ft. box <b>27M19</b>
22 AWG, yellow jacket, rated at 75°C, 300V, Plenum rated	1000 ft. box <b>94L63</b>
Insulation - Low smoke PVC, NEC, CMP	2500 ft. roll <b>68M25</b>
<b>ComfortSense® 7500 Commercial 7-Day Programmable Thermostat</b>	
CS7500 7-Day Thermostat	<b>17G74</b>
Sensors/Accessories	<sup>2</sup> Remote non-adjustable wall-mount 20k <b>47W36</b>
	<sup>2</sup> Remote non-adjustable wall-mount 10k <b>47W37</b>
	Remote non-adjustable discharge air (duct mount) <b>19L22</b>
	Outdoor temperature sensor <b>X2658</b>
<b>ComfortSense® 3000 Commercial 5-2 Day Programmable Thermostat</b>	
CS3000 5-2 Day Thermostat	<b>11Y05</b>
Sensors/Accessories	Remote non-adjustable wall mount 10k averaging <b>47W37</b>
	Thermostat wall mounting plate <b>X2659</b>
<b>ComfortSense® Non-Programmable Thermostat</b>	
CS3000 Non-Programmable Thermostat	<b>51M32</b>
<b>Universal Thermostat Guard with Lock (clear)</b>	
	Inside Dimensions (H x W) 5 7/8 x 8 3/8 in. <b>39P21</b>
<b>Wireless/Wired Room Sensor</b>	
LCS-5030 Wireless/Wired Room Sensor	<b>21L07</b>
	Wireless Repeater for Room Sensor - Temperature and humidity, no display <b>21L09</b>

<sup>1</sup> Up to nine of the same type remote temperature sensors can be connected in parallel.

<sup>2</sup> Remote wall-mount sensors can be applied in any of the following combinations:

One Sensor - (1) 47W36, Two Sensors - (2) 47W37, Three Sensors - (2) 47W36 and (1) 47W37

Four Sensors - (4) 47W36, Five Sensors - (3) 47W36 and (2) 47W37

## SEQUENCE OF OPERATION

### **COOLING**

#### **A-Two-Stage Thermostat**

1 - Economizer With Outdoor Air Suitable

##### **Y1 Demand**

- Compressors Off
- Blower Cooling Low
- Dampers Modulate

*NOTE - If dampers are at maximum open for five minutes, blower runs at cooling high.*

##### **Y2 Demand**

- Compressors Modulate
- Blower Cooling High
- Dampers Maximum Open

2 - No Economizer or Outdoor Air Not Suitable

##### **Y1 Demand**

- Compressors Modulate
- Blower Cooling Low
- Dampers Minimum Position

##### **Y2 Demand**

- Compressors Modulate
- Blower Cooling High
- Dampers Minimum Position

#### **B-Three-Stage Thermostat**

1 - Economizer With Outdoor Air Suitable

##### **Y1 Demand**

- Compressors Off
- Blowers Cooling Low
- Dampers Modulate

*NOTE - If dampers are at maximum open for five minutes, blower runs at cooling intermediate.*

##### **Y2 Demand**

- Compressors Modulate
- Blower Cooling Intermediate
- Dampers Maximum Open

##### **Y3 Demand**

- Compressors Modulate
- Blower Cooling High
- Dampers Maximum Open

## SEQUENCE OF OPERATION

### **COOLING (CONTINUED)**

2 - No Economizer or Outdoor Air Not Suitable

#### **Y1 Demand**

- Compressors Modulate
- Blower Cooling Low
- Dampers Minimum Position

#### **Y2 Demand**

- Compressors Modulate
- Blower Cooling Intermediate
- Dampers Minimum Position

#### **Y3 Demand**

- Compressors Modulate
- Blower Cooling High
- Dampers Minimum Position

### **C - Room Sensor**

1 - Economizer With Outdoor Air Suitable

- Compressors Off
- Blower Modulates
- Dampers Modulate

*NOTE - If dampers are at maximum open for five minutes, compressors are energized and the blower modulates.*

2 - No Economizer or Outdoor Air Not Suitable

- Compressors Modulate
- Blower Modulates
- Dampers Minimum Position

*NOTE - Free cooling is locked out when a dehumidification demand is received. The unit operates in dehumidification mode as if the outdoor air is not suitable.*

### **HEATING**

**Heating Mode: Thermostat or Room Sensor (Up to 2 stages W1, W2)**

#### **W1 or Low Heating Demand**

Gas valve is open on low and the supply fan operates at high speed.

#### **W2 or High Heating Demand**

Gas valve is open on high and the supply fan operates at high speed.



## SEQUENCE OF OPERATION

### **HUMIDITROL™±**

#### **A - Thermostat Mode With 24V Humidistat**

Dehumidification Demand (DI4) and No Cooling Demand

Compressor operates at 100%, blower and outdoor fans modulate to maintain indoor coil and discharge air temperatures, reheat valve is energized.

##### **Y1 and DI4 Demand**

Compressors are modulating, blower is on low, and the reheat valve is de-energized.

##### **Y2 and DI4 Demand**

Compressors are modulating, blower is on high, reheat valve is de-energized.

#### **B - Thermostat Mode With Zone Relative Humidity Sensor**

Dehumidification Demand (Zone Relative Humidity is greater than the relative humidity setpoint) and No Cooling Demand

Compressor modulates based on zone relative humidity, blower and outdoor fans modulate to maintain indoor coil and discharge air temperatures, reheat valve is energized.

Y1 and Dehumidification Demand

Compressors are modulating, blower is on low, and the reheat valve is de-energized.

Y2 and Dehumidification Demand

Compressors are modulating, blower is on high, reheat valve is de-energized.

#### **C - Room Sensor Mode With Humidistat**

Dehumidification Demand (DI4) and No Cooling Demand

Compressor 1 operates at 100%, blower and outdoor fans modulate to maintain indoor coil and discharge air temperatures, reheat valve is energized.

Cooling and Dehumidification Demand

Compressors are modulating, blower is modulating, reheat valve is de-energized.

#### **D - Room Sensor Mode With Zone Relative Humidity Sensor**

Dehumidification Demand (Zone Relative Humidity is greater than the relative humidity setpoint) and No Cooling Demand

Compressor 1 modulates based on zone relative humidity, blower and outdoor fans modulate to maintain indoor coil and discharge air temperatures, reheat valve is energized.

Cooling and Dehumidification Demand

Compressors are modulating, blower is modulating, and the reheat valve is de-energized.

## OPTIONS / ACCESSORIES

Item Description	Catalog Number	Unit Model No				
		092	102	120	150	
<b>COOLING SYSTEM</b>						
Condensate Drain Trap	PVC	<b>22H54</b>	OX	OX	OX	OX
	Copper	<b>76W27</b>	X	X	X	X
Corrosion Protection	Factory		O	O	O	O
Drain Pan Overflow Switch	<b>21Z07</b>		OX	OX	OX	OX
Refrigerant Type	R-410A		O	O	O	O
Service Valves (not for Humiditrol™+ equipped units)	Factory		O	O	O	O
<b>HEATING SYSTEM</b>						
Bottom Gas Piping Kit	<b>54W95</b>		OX	OX	OX	OX
Combustion Air Intake Extensions	<b>19W51</b>		X	X	X	X
Gas Heat Input	130,000 Btuh	Factory	O	O	O	O
	180,000 Btuh	Factory	O	O	O	O
	240,000 Btuh	Factory	O	O	O	O
Low Temperature Vestibule Heater	208/230V-3ph	<b>22A51</b>	OX	OX	OX	OX
	460V-3ph	<b>22A55</b>	OX	OX	OX	OX
	575V-3ph	<b>13X65</b>	OX	OX	OX	OX
LPG/Propane Conversion Kits	Standard Heat	<b>14N22</b>	X	X	X	X
	Medium Heat	<b>14N23</b>	X	X	X	X
	High Heat	<b>14N25</b>	X	X	X	X
Stainless Steel Heat Exchanger	Factory		O	O	O	O
Vertical Vent Extension Kit	<b>42W16</b>		X	X	X	X
<b>BLOWER - SUPPLY AIR</b>						
Blower	DirectPlus™ Direct Drive ECM Blower System with SZVAV	Factory	O	O	O	O
	DirectPlus™ Direct Drive ECM Blower System with VAV	Factory	O	O	O	O
<b>CABINET</b>						
Combination Coil/Hail Guards	<b>22J65</b>		X	X		
	<b>13T05</b>				X	X
Horizontal Discharge Kit	<b>51W25</b>		X	X	X	X
Return Air Adaptor Plate (for LC/LG and TC/TG/TH unit replacement)	<b>54W96</b>		OX	OX	OX	OX
<b>CONTROLS</b>						
Blower Proving Switch	<b>21Z10</b>		OX	OX	OX	OX
Commercial Controls	LonTalk® Module - For Lennox® CORE Control System	<b>54W27</b>	OX	OX	OX	OX
	Novar® LSM	Factory	O	O	O	O
	L Connection® Building Automation System	Factory	X	X	X	X
Dirty Filter Switch	<b>53W67</b>		OX	OX	OX	OX
Fresh Air Tempering	<b>21Z08</b>		OX	OX	OX	OX
Smoke Detector - Supply or Return (Power board and one sensor)	<b>11K76</b>		OX	OX	OX	OX
Smoke Detector - Supply and Return (Power board and two sensors)	<b>11K80</b>		OX		OX	OX

NOTE - Catalog numbers shown are for ordering optional accessories if a field installed option is available.

OX - Configure To Order (Factory Installed) or Field Installed

O = Configure To Order (Factory Installed)

X = Field Installed

## OPTIONS / ACCESSORIES

Item Description	Catalog Number	Unit Model No				
		092	102	120	150	
<b>INDOOR AIR QUALITY</b>						
<b>Air Filters</b>						
Healthy Climate® High Efficiency Air Filters 20 x 25 x 2 in.	MERV 8 (Order 4)	<b>50W61</b>	OX	OX	OX	OX
	MERV 13 (Order 4)	<b>52W41</b>	OX	OX	OX	OX
	MERV 16 (Order 4)	<b>21U41</b>	OX	OX	OX	OX
Replacement Media Filter With Metal Mesh Frame 20 x 25 x 2 in. (includes non-pleated filter media)	(Order 4)	<b>Y3063</b>	X	X	X	X
<b>Indoor Air Quality (CO<sub>2</sub>) Sensors</b>						
Sensor - Wall-mount, off-white plastic cover with LCD display		<b>77N39</b>	X	X	X	X
Sensor - Wall-mount, off-white plastic cover, no display		<b>87N53</b>	X	X	X	X
Sensor - Black plastic case with LCD display, rated for plenum mounting		<b>87N52</b>	X	X	X	X
Sensor - Wall-mount, black plastic case, no display, rated for plenum mounting		<b>87N54</b>	X	X	X	X
CO <sub>2</sub> Sensor Duct Mounting Kit - for downflow applications		<b>85L43</b>	X	X	X	X
Aspiration Box - for duct mounting non-plenum rated CO <sub>2</sub> sensors ( <b>87N53</b> or <b>77N39</b> )		<b>90N43</b>	X	X	X	X
<b>Needlepoint Bipolar Ionization (NPBI)</b>						
Needlepoint Bipolar Ionization (NPBI) Kit		<b>21U36</b>	OX	OX	OX	OX
<b>UVC Germicidal Lamps</b>						
<sup>1</sup> Healthy Climate® UVC Light Kit (110//230V-1ph)		<b>21A93</b>	OX	OX	OX	OX
<b>ELECTRICAL</b>						
Voltage 60 Hz	208/230V - 3 phase	Factory	O	O	O	O
	460V - 3 phase	Factory	O	O	O	O
	575V - 3 phase	Factory	O	O	O	O
HACR Circuit Breakers		Factory	O	O	O	O
<sup>2</sup> Short-Circuit Current Rating (SCCR) of 100kA (includes Phase/Voltage Detection)		Factory	O	O	O	O
Disconnect Switch	80 amp	<b>54W56</b>	OX	OX	OX	OX
	150 amp	<b>54W57</b>	OX	OX	OX	OX
GFI Service Outlets	15 amp non-powered, field-wired (208/230V, 460V only)	<b>74M70</b>	OX	OX	OX	OX
	20 amp non-powered, field-wired (575V only)	<b>67E01</b>	OX	OX	OX	OX
Weatherproof Cover for GFI		<b>10C89</b>	X	X	X	X

<sup>1</sup> For 460V and 575V units, field installed lamps utilize jumpers to the outdoor fan transformer for voltage needed. See the installation Instructions.

<sup>2</sup> Disconnect Switch not available with higher SCCR option.

NOTE - Catalog numbers shown are for ordering optional accessories if a field installed option is available.

OX - Configure To Order (Factory Installed) or Field Installed

O = Configure To Order (Factory Installed)

X = Field Installed

## OPTIONS / ACCESSORIES

Item Description	Catalog Number	Unit Model No			
		092	102	120	150
<b>ECONOMIZER</b>					
<b>High Performance Economizer (Approved for California Title 24 Building Standards / AMCA Class 1A Certified)</b>					
High Performance Economizer Downflow or Horizontal - Includes Outdoor Air Hood and Downflow Barometric Relief Dampers with Exhaust Hood NOTE - For horizontal economizer applications order optional Horizontal Low Profile Barometric Relief Dampers and Horizontal Discharge Kit separately.	20U80	OX	OX	OX	OX
<b>Economizer Controls</b>					
Differential Enthalpy (Not for Title 24)	Order 2 21Z09	OX	OX	OX	OX
Sensible Control	Sensor is Furnished Factory	O	O	O	O
Single Enthalpy (Not for Title 24)	21Z09	OX	OX	OX	OX
Global Control	Sensor Field Provided Factory	O	O	O	O
Building Pressure Control	13J77	X	X	X	X
Outdoor Air CFM Control	13J76	X	X	X	X
<b>Horizontal Barometric Relief Dampers (for horizontal economizer applications)</b>					
Horizontal Low Profile Barometric Relief Dampers With Exhaust Hood	53K04	X	X	X	X
<b>OUTDOOR AIR</b>					
<b>Outdoor Air Dampers</b>					
Motorized Dampers (Hood furnished)	14G28	OX	OX	OX	OX
Manual Dampers (Hood furnished)	14G29	OX	OX	OX	OX
<b>POWER EXHAUST</b>					
Standard Static	208/230V-3ph 53W44	OX	OX	OX	OX
	460V-3ph 53W45	OX	OX	OX	OX
	575V-3ph 53W46	OX	OX	OX	OX
<b>HUMIDITROL™+ HOT GAS REHEAT OPTION</b>					
Humiditrol+ Dehumidification Option	Factory	O	O	O	O
<b>ROOF CURBS</b>					
<b>Hybrid Roof Curbs, Downflow</b>					
8 in. height	11F54	X	X	X	X
14 in. height	11F55	X	X	X	X
18 in. height	11F56	X	X	X	X
24 in. height	11F57	X	X	X	X
<b>Adjustable Pitch Curb, Downflow</b>					
14 in. height	54W50	X	X	X	X
<b>CEILING DIFFUSERS</b>					
Step-Down - Order one	RTD11-95S 13K61	X			
	RTD11-135S 13K62		X	X	
	RTD11-185S 13K63				X
Flush - Order one	FD11-95S 13K56	X			
	FD11-135S 13K57		X	X	
	FD11-185S 13K58				X
Transitions (Supply and Return) - Order one	C1DIFF30B-1 12X65	X			
	C1DIFF31B-1 12X66		X	X	
	C1DIFF32B-1 12X67				X

NOTE - Catalog numbers shown are for ordering optional accessories if a field installed option is available.

OX - Configure To Order (Factory Installed) or Field Installed

O = Configure To Order (Factory Installed)

X = Field Installed

SPECIFICATIONS			UNIT				
<b>General Data</b>	<b>Nominal Tonnage</b>		<b>7.5 Ton</b>	<b>8.5 Ton</b>	<b>10 Ton</b>	<b>12.5 Ton</b>	
	<b>Efficiency Type</b>		<b>Ultra-High</b>	<b>Ultra-High</b>	<b>Ultra-High</b>	<b>Ultra-High</b>	
	<b>Model Number</b>		<b>LGM092U4E</b>	<b>LGM102U4E</b>	<b>LGM120U4E</b>	<b>LGM150U4E</b>	
	<b>Blower Type</b>		DirectPlus™ ECM Direct Drive with SZVAV	DirectPlus™ ECM Direct Drive with SZVAV	DirectPlus™ ECM Direct Drive with SZVAV	DirectPlus™ ECM Direct Drive with SZVAV	
	<b>Model Number</b>		<b>LGM092U4P</b>	<b>LGM102U4P</b>	<b>LGM120U4P</b>	<b>LGM150U4P</b>	
	<b>Blower Type</b>		DirectPlus™ ECM Direct Drive with VAV	DirectPlus™ ECM Direct Drive with VAV	DirectPlus™ ECM Direct Drive with VAV	DirectPlus™ ECM Direct Drive with VAV	
	<b>Cooling Performance</b>	Gross Cooling Capacity - Btuh		90,500	101,600	121,800	144,000
		<sup>1</sup> Net Cooling Capacity - Btuh		86,000	97,000	114,000	138,000
<sup>1</sup> AHRI Rated Air Flow - cfm		2800	3400	3600	4400		
Total Unit Power - kW		7.2	8.1	9.5	12.5		
<sup>1</sup> IEER (Btuh/Watt)		22.0	21.0	21.0	20.0		
<sup>1</sup> EER (Btuh/Watt)		12.4	12.4	12.0	11.0		
<b>Refrigerant Charge</b>		Refrigerant Type		R-410A	R-410A	R-410A	R-410A
	Without Reheat Option	Circuit 1	13 lbs. 11 oz.	13 lbs. 15 oz.	15 lbs. 8 oz.	15 lb. 12 oz.	
		Circuit 2	9 lbs. 13 oz.	9 lbs. 10 oz.	11 lbs. 2 oz.	10 lb. 8 oz.	
	With Reheat Option	Circuit 1	15 lbs. 0 oz.	15 lbs. 0 oz.	18 lbs. 12 oz.	19 lb. 12 oz.	
		Circuit 2	9 lbs. 13 oz.	9 lbs. 10 oz.	11 lbs. 2 oz.	10 lb. 8 oz.	
<b>Gas Heating Options Available - See page 22</b>			Standard (2 Stage), Medium (2 Stage), High (2 Stage)				
<b>Compressor Type (number)</b>			Variable Capacity Scroll (1) Fixed Capacity Scroll (1)				
<b>Outdoor Coils</b>	Net face area (total) - sq. ft.		20.5	20.5	28	28	
	Tube diameter - in.		3/8	3/8	3/8	3/8	
	Number of rows		3	3	3	3	
	Fins per inch		20	20	20	20	
<b>Outdoor Coil Fans</b>	Motor - (No.) HP		(2) 1/3 ECM	(2) 1/3 ECM	(2) 1/3 ECM	(2) 1/3 ECM	
	Motor rpm		400-850	400-1020	500-1020	500-1020	
	Total Motor watts		65-450	65-750	65-750	65-750	
	Diameter - (No.) in.		(2) 24	(2) 24	(2) 24	(2) 24	
	Number of blades		3	3	3	3	
	Total Air volume - cfm		7300	8800	8800	8800	
<b>Indoor Coil</b>	Net face area (total) - sq. ft.		13.54	13.54	13.54	13.54	
	Tube diameter - in.		3/8	3/8	3/8	3/8	
	Number of rows		4	4	4	4	
	Fins per inch		14	14	14	14	
	Drain connection - Number and size		(1) 1 in. NPT coupling				
Expansion device type		Balance port TXV, removable head					
<b>Indoor Blower</b>	Nominal motor output		3.75 HP (ECM)	3.75 HP (ECM)	3.75 HP (ECM)	3.75 HP (ECM)	
	Blower wheel nominal diameter x width - in.		(1) 22 x 9	(1) 22 x 9	(1) 22 x 9	(1) 22 x 9	
<b>Filters</b>	Type of filter		Disposable				
	Number and size - in.		(4) 20 x 25 x 2				
<b>Electrical characteristics</b>			208/230V, 460V, or 575V - 60 hz -3 phase				

NOTE - Net capacity includes evaporator blower motor heat deduction. Gross capacity does not include evaporator blower motor heat deduction.

<sup>1</sup> AHRI Certified to AHRI Standard 340/360; 95°F outdoor air temperature and 80°F db/67°F wb entering evaporator air; minimum external duct static pressure.

## SPECIFICATIONS

## GAS HEAT

Heat Input Type			Standard	Medium	High
Number of Gas Heat Stages			2	2	2
Gas Heating Performance	Input - Btuh	First Stage	84,500	117,000	156,000
		Second Stage	130,000	180,000	240,000
	Output - Btuh	Second Stage	104,000	144,000	192,000
	Temperature Rise Range - °F		15 - 45	30 - 60	40 - 70
	Thermal Efficiency		80%	80%	80%
	Gas Supply Connections		3/4 in. npt	3/4 in. npt	3/4 in. npt.
Recommended Gas Supply Pressure - in. w.g.	Natural		7 in. w.c.	7 in. w.c.	7 in. w.c.
	LPG/Propane		11 in. w.c.	11 in. w.c.	11 in. w.c.

## HIGH ALTITUDE DERATE

Units may be installed at altitudes up to 2000 feet above sea level without any modification.

At altitudes above 2000 feet, units must be derated to match gas manifold pressures shown in table below.

At altitudes above 4500 feet unit must be derated 2% for each 1000 feet above sea level.

NOTE - This is the only permissible derate for these units.

Gas Heat Type	Altitude Feet	Gas Manifold Pressure in. w.g.		Input Rate - Btuh (Natural Gas or LPG/Propane)	
		Natural Gas	LPG/Propane Gas	First Stage	Second Stage
Standard	2001-4500	3.4	9.6	84,500	124,000
Medium	2001-4500	3.4	9.6	117,000	172,000
High	2001-4500	3.4	9.6	156,000	230,000







# HUMIDITROL™ + DEHUMIDIFICATION SYSTEM RATINGS

## 7.5 | 8.5 TON - LGM092U4E/P / LGM102U4E/P WITH HUMIDITROL™+ OPERATING

Entering Wet Bulb Temperature	Outdoor Air Temperature Entering Outdoor Coil																							
	65°F						75°F						85°F						95°F					
	Total Air Vol.	Total Cool Cap.	Comp. Motor Input	Sensible To Total Ratio (S/T)			Total Air Vol.	Total Cool Cap.	Comp. Motor Input	Sensible To Total Ratio (S/T)			Total Air Vol.	Total Cool Cap.	Comp. Motor Input	Sensible To Total Ratio (S/T)			Total Air Vol.	Total Cool Cap.	Comp. Motor Input	Sensible To Total Ratio (S/T)		
				Dry Bulb						Dry Bulb						Dry Bulb						Dry Bulb		
cfm	kBtuh	kW	75°F	80°F	85°F	cfm	kBtuh	kW	75°F	80°F	85°F	cfm	kBtuh	kW	75°F	80°F	85°F	cfm	kBtuh	kW	75°F	80°F	85°F	
63°F	1201	23.6	2.2	0.5	0.7	1.0	1152	23.0	2.2	0.5	0.7	0.9	1059	17.8	2.4	0.4	0.6	0.9	879	10.5	2.7	0.1	0.4	0.8
67°F	895	28.2	2.2	0.3	0.4	0.6	866	27.1	2.2	0.3	0.4	0.6	814	20.9	2.4	0.2	0.4	0.5	759	14.4	2.8	N/A	0.2	0.4
71°F	684	31.5	2.1	0.2	0.3	0.4	686	29.8	2.1	0.2	0.3	0.4	642	23.8	2.5	0.1	0.2	0.3	576	17.7	2.8	N/A	0.1	0.2

NOTE - Both compressors operating at maximum capacity, indoor blower operating at optimal CFM and outdoor fan operating to maintain a discharge air temperature target equal to indoor dry bulb temperature.

## 10 TON - LGM120U4E/P WITH HUMIDITROL™+ OPERATING

Entering Wet Bulb Temperature	Outdoor Air Temperature Entering Outdoor Coil																							
	65°F						75°F						85°F						95°F					
	Total Air Vol.	Total Cool Cap.	Comp. Motor Input	Sensible To Total Ratio (S/T)			Total Air Vol.	Total Cool Cap.	Comp. Motor Input	Sensible To Total Ratio (S/T)			Total Air Vol.	Total Cool Cap.	Comp. Motor Input	Sensible To Total Ratio (S/T)			Total Air Vol.	Total Cool Cap.	Comp. Motor Input	Sensible To Total Ratio (S/T)		
				Dry Bulb						Dry Bulb						Dry Bulb						Dry Bulb		
cfm	kBtuh	kW	75°F	80°F	85°F	cfm	kBtuh	kW	75°F	80°F	85°F	cfm	kBtuh	kW	75°F	80°F	85°F	cfm	kBtuh	kW	75°F	80°F	85°F	
63°F	1382	30.7	3.1	0.4	0.6	0.8	1267	26.5	3.2	0.4	0.6	0.8	1170	24.1	3.2	0.3	0.6	0.8	1042	16.0	3.5	0.1	0.4	0.7
67°F	1067	34.6	3.1	0.2	0.4	0.5	1021	33.0	3.0	0.2	0.4	0.5	900	27.1	3.2	0.2	0.3	0.5	802	20.4	3.6	N/A	0.2	0.4
71°F	864	40.0	2.9	0.2	0.3	0.4	808	37.1	2.9	0.2	0.3	0.4	739	30.5	3.2	0.1	0.2	0.3	728	24.6	3.6	N/A	0.1	0.2

NOTE - Both compressors operating at maximum capacity, indoor blower operating at optimal CFM and outdoor fan operating to maintain a discharge air temperature target equal to indoor dry bulb temperature.

## 12.5 TON - LGM150U4E/P WITH HUMIDITROL™+ OPERATING

Entering Wet Bulb Temperature	Outdoor Air Temperature Entering Outdoor Coil																							
	65°F						75°F						85°F						95°F					
	Total Air Vol.	Total Cool Cap.	Comp. Motor Input	Sensible To Total Ratio (S/T)			Total Air Vol.	Total Cool Cap.	Comp. Motor Input	Sensible To Total Ratio (S/T)			Total Air Vol.	Total Cool Cap.	Comp. Motor Input	Sensible To Total Ratio (S/T)			Total Air Vol.	Total Cool Cap.	Comp. Motor Input	Sensible To Total Ratio (S/T)		
				Dry Bulb						Dry Bulb						Dry Bulb						Dry Bulb		
cfm	kBtuh	kW	75°F	80°F	85°F	cfm	kBtuh	kW	75°F	80°F	85°F	cfm	kBtuh	kW	75°F	80°F	85°F	cfm	kBtuh	kW	75°F	80°F	85°F	
63°F	1675	24.0	4.2	0.4	0.6	0.8	1556	31.7	4.1	0.4	0.6	0.8	1406	28.8	4.1	0.3	0.6	0.8	1309	19.9	4.5	0.2	0.5	0.8
67°F	1248	40.5	4.1	0.2	0.4	0.5	1215	38.9	4.0	0.2	0.4	0.5	1119	32.9	4.1	0.2	0.3	0.5	1020	24.7	4.6	N/A	0.2	0.4
71°F	1015	47.2	3.8	0.2	0.3	0.4	1009	43.8	3.8	0.2	0.3	0.4	932	36.2	4.2	0.0	0.2	0.3	927	29.7	4.6	N/A	0.1	0.2

NOTE - Both compressors operating at maximum capacity, indoor blower operating at optimal CFM and outdoor fan operating to maintain a discharge air temperature target equal to indoor dry bulb temperature.

## BLOWER DATA

**BLOWER TABLE INCLUDES RESISTANCE FOR BASE UNIT ONLY (NO HEAT SECTION) WITH DRY INDOOR COIL AND AIR FILTERS IN PLACE.**

FOR ALL UNITS ADD:

- 1 - Wet indoor coil air resistance of selected unit.
  - 2 - Any factory installed options air resistance (heat section, Economizer, etc.)
  - 3 - Any field installed accessories air resistance (duct resistance, diffuser, etc.)
- See page 27 for wet coil and option/accessory air resistance data.

### MAXIMUM STATIC PRESSURE WITH GAS HEAT - 2.0 in. w.g.

Total Air Volume cfm	Total Static Pressure - in. w.g.													
	0.2		0.4		0.6		0.8		1.0		1.2		1.4	
	RPM	Watts	RPM	Watts	RPM	Watts	RPM	Watts	RPM	Watts	RPM	Watts	RPM	Watts
1750	711	188	771	279	836	366	905	453	975	544	1044	640	1109	737
2000	752	242	812	332	876	420	944	510	1011	606	1075	709	1138	812
2250	799	300	860	389	923	479	988	575	1052	678	1113	787	1171	896
2500	853	362	914	453	976	548	1038	650	1097	761	1154	877	1209	990
2750	914	434	974	529	1033	629	1091	739	1146	858	1199	979	1250	1098
3000	980	513	1037	614	1092	720	1146	837	1198	961	1247	1088	1295	1215
3250	1048	598	1101	705	1153	819	1203	941	1251	1071	1298	1206	1343	1343
3500	1116	693	1166	809	1214	931	1261	1060	1307	1198	1351	1341	1395	1489
3750	1185	806	1232	931	1277	1063	1322	1201	1365	1348	1407	1499	1448	1657
4000	1254	937	1299	1072	1341	1214	1383	1363	1424	1518	1464	1679	1503	1844
4250	1324	1089	1366	1234	1406	1386	1445	1545	1484	1708	1522	1876	1559	2046
4500	1395	1262	1433	1417	1471	1579	1508	1745	1544	1913	1581	2084	1616	2256
4750	1465	1455	1501	1619	1536	1787	1571	1957	1606	2128	1641	2299	1675	2470
5000	1534	1666	1568	1834	1602	2004	1635	2174	1668	2345	1701	2514	1735	2682
5250	1603	1887	1635	2055	1667	2224	1699	2392	1731	2559	1763	2724	---	---
5500	1671	2110	1702	2275	1733	2441	1764	2605	---	---	---	---	---	---
5750	1738	2325	1768	2488	---	---	---	---	---	---	---	---	---	---

Total Air Volume cfm	Total Static Pressure - in. w.g.											
	1.6		1.8		2.0		2.2		2.4		2.6	
	RPM	Watts	RPM	Watts	RPM	Watts	RPM	Watts	RPM	Watts	RPM	Watts
1750	1172	833	1231	932	1287	1039	1340	1156	1391	1283	1442	1426
2000	1197	913	1253	1019	1306	1135	1357	1261	1407	1398	1457	1547
2250	1227	1003	1280	1117	1330	1242	1379	1378	1428	1525	1477	1680
2500	1261	1103	1311	1226	1360	1361	1407	1507	1454	1663	1501	1826
2750	1299	1219	1347	1350	1394	1494	1440	1649	1485	1813	1530	1982
3000	1342	1346	1388	1487	1432	1640	1476	1803	1520	1973	1563	2146
3250	1388	1485	1432	1638	1475	1800	1517	1969	1558	2143	1600	2319
3500	1437	1643	1479	1805	1519	1975	1560	2148	1600	2325	1640	2502
3750	1489	1821	1528	1990	1567	2164	1605	2340	1645	2517	1685	2693
4000	1541	2014	1579	2187	1616	2364	1654	2540	1693	2715	1732	2887
4250	1596	2218	1632	2393	1668	2569	1705	2742	1743	2913	---	---
4500	1652	2429	1687	2603	1722	2775	1759	2944	---	---	---	---
4750	1709	2641	1743	2811	1778	2979	---	---	---	---	---	---
5000	1768	2850	---	---	---	---	---	---	---	---	---	---
5250	---	---	---	---	---	---	---	---	---	---	---	---
5500	---	---	---	---	---	---	---	---	---	---	---	---
5750	---	---	---	---	---	---	---	---	---	---	---	---

## BLOWER DATA

### POWER EXHAUST FAN PERFORMANCE

Return Air System Static Pressure	Air Volume Exhausted
in. w.g.	cfm
0	3175
0.05	2955
0.10	2685
0.15	2410
0.20	2165
0.25	1920
0.30	1420
0.35	1200

### FACTORY INSTALLED OPTIONS/FIELD INSTALLED ACCESSORY AIR RESISTANCE - in. w.g.

Air Volume cfm	Wet Indoor Coil		Gas Heat Exchanger			Economizer	Humiditrol™ + Reheat Coil	Filters			Return Air Adaptor Plate
			Standard Heat	Medium Heat	High Heat			MERV 8	MERV 13	MERV 16	
	092, 102	120, 150									
1750	0.04	0.04	0.06	0.02	0.02	0.05	0.02	0.01	0.03	0.06	0.00
2000	0.05	0.05	0.07	0.05	0.06	0.06	0.02	0.01	0.03	0.08	0.00
2250	0.06	0.06	0.07	0.07	0.08	0.08	0.02	0.01	0.04	0.09	0.00
2500	0.07	0.07	0.09	0.10	0.11	0.11	0.03	0.01	0.05	0.10	0.00
2750	0.08	0.08	0.09	0.11	0.12	0.12	0.03	0.02	0.05	0.11	0.00
3000	0.10	0.09	0.11	0.12	0.13	0.13	0.03	0.02	0.06	0.12	0.02
3250	0.11	0.10	0.12	0.15	0.16	0.15	0.04	0.02	0.06	0.13	0.02
3500	0.12	0.11	0.12	0.16	0.17	0.15	0.04	0.03	0.07	0.15	0.04
3750	0.14	0.13	0.14	0.19	0.20	0.15	0.05	0.03	0.08	0.16	0.07
4000	0.15	0.14	0.14	0.21	0.22	0.19	0.05	0.04	0.08	0.17	0.09
4250	0.17	0.15	0.14	0.24	0.28	0.19	0.06	0.04	0.09	0.19	0.11
4500	0.19	0.17	0.15	0.26	0.32	0.22	0.07	0.04	0.09	0.20	0.12
4750	0.20	0.18	0.16	0.29	0.37	0.25	0.07	0.05	0.10	0.21	0.16
5000	0.22	0.20	0.16	0.34	0.43	0.29	0.08	0.06	0.10	0.23	0.18
5250	0.24	0.22	0.16	0.37	0.47	0.32	0.08	0.06	0.11	0.24	0.19
5500	0.25	0.23	0.18	0.44	0.54	0.34	0.09	0.07	0.12	0.25	0.22
5750	0.27	0.25	0.19	0.49	0.59	0.45	0.10	0.07	0.12	0.27	0.25
6000	0.29	0.27	0.20	0.54	0.64	0.52	0.10	0.08	0.13	0.28	0.27

## BLOWER DATA

### CEILING DIFFUSERS AIR RESISTANCE - in. w.g.

Unit Size	RTD11 Step-Down Diffuser			FD11 Flush Diffuser	
	Air Volume cfm	2 Ends Open	1 Side, 2 Ends Open		All Ends & Sides Open
092 Models	2400	0.21	0.18	0.15	0.14
	2600	0.24	0.21	0.18	0.17
	2800	0.27	0.24	0.21	0.20
	3000	0.32	0.29	0.25	0.25
	3200	0.41	0.37	0.32	0.31
	3400	0.50	0.45	0.39	0.37
	3600	0.61	0.54	0.48	0.44
	3800	0.73	0.63	0.57	0.51
102 & 120 Models	3600	0.36	0.28	0.23	0.15
	3800	0.40	0.32	0.26	0.18
	4000	0.44	0.36	0.29	0.21
	4200	0.49	0.40	0.33	0.24
	4400	0.54	0.44	0.37	0.27
	4600	0.60	0.49	0.42	0.31
	4800	0.65	0.53	0.46	0.35
	5000	0.69	0.58	0.50	0.39
150 Models	5200	0.75	0.62	0.54	0.43
	4200	0.22	0.19	0.16	0.10
	4400	0.28	0.24	0.20	0.12
	4600	0.34	0.29	0.24	0.15
	4800	0.40	0.34	0.29	0.19
	5000	0.46	0.39	0.34	0.23
	5200	0.52	0.44	0.39	0.27
	5400	0.58	0.49	0.43	0.31
5600	0.64	0.54	0.47	0.35	
5800	0.70	0.59	0.51	0.39	

### CEILING DIFFUSER AIR THROW DATA

Model No.	Air Volume cfm	<sup>1</sup> Effective Throw Range	
		RTD11 Step-Down	FD11 Flush
		ft.	ft.
092 Models	2600	24 - 29	19 - 24
	2800	25 - 30	20 - 28
	3000	27 - 33	21 - 29
	3200	28 - 35	22 - 29
	3400	30 - 37	22 - 30
102, 120 Models	3600	25 - 33	22 - 29
	3800	27 - 35	22 - 30
	4000	29 - 37	24 - 33
	4200	32 - 40	26 - 35
	4400	34 - 42	28 - 37
150 Models	5600	39 - 49	28 - 37
	5800	42 - 51	29 - 38
	6000	44 - 54	40 - 50
	6200	45 - 55	42 - 51
	6400	46 - 55	43 - 52
6600	47 - 56	45 - 56	

<sup>1</sup> Throw is the horizontal or vertical distance an air stream travels on leaving the outlet or diffuser before the maximum velocity is reduced to 50 ft. per minute. Four sides open.

**ELECTRICAL DATA****7.5 TON**

Model No.		LGM092U4E/ LGM092U4P		
<sup>1</sup> Voltage - 60Hz		208/230V-3ph	460V-3ph	575V-3ph
Compressor 1	Rated Load Amps	8.5	4	3.2
	Locked Rotor Amps	17	10	12
Compressor 2	Rated Load Amps	13.7	6.1	4.8
	Locked Rotor Amps	83.1	43	33
Outdoor Fan Motors (2)	Full Load Amps	2.8	1.4	1.1
	(total)	(5.6)	(2.8)	(2.2)
Power Exhaust (1) 0.33 HP	Full Load Amps	2.4	1.3	1
Service Outlet 115V GFI (amps)		15	15	20
Indoor Blower Motor	Horsepower	3.75	3.75	3.75
	Full Load Amps	8.8	4.3	3.4
<sup>2</sup> Maximum Overcurrent Protection (MOCP)	Unit Only	50	20	15
	With (1) 0.33 HP Power Exhaust	50	25	20
<sup>3</sup> Minimum Circuit Ampacity (MCA)	Unit Only	41	19	15
	With (1) 0.33 HP Power Exhaust	43	21	16

NOTE - All units have a minimum Short Circuit Current Rating (SCCR) of 5000 amps.

<sup>1</sup> Extremes of operating range are plus and minus 10% of line voltage.<sup>2</sup> HACR type breaker or fuse.<sup>3</sup> Refer to National or Canadian Electrical Code manual to determine wire, fuse and disconnect size requirements.**ELECTRICAL DATA****8.5 TON**

Model No.		LGM102U4E/ LGM102U4P		
<sup>1</sup> Voltage - 60Hz		208/230V-3ph	460V-3ph	575V-3ph
Compressor 1	Rated Load Amps	11.8	5.5	4.4
	Locked Rotor Amps	17	10	12
Compressor 2	Rated Load Amps	13.7	6.1	4.8
	Locked Rotor Amps	83.1	43	33
Outdoor Fan Motors (2)	Full Load Amps	2.8	1.4	1.1
	(total)	(5.6)	(2.8)	(2.2)
Power Exhaust (1) 0.33 HP	Full Load Amps	2.4	1.3	1
Service Outlet 115V GFI (amps)		15	15	20
Indoor Blower Motor	Horsepower	3.75	3.75	3.75
	Full Load Amps	8.8	4.3	3.4
<sup>2</sup> Maximum Overcurrent Protection (MOCP)	Unit Only	50	25	20
	With (1) 0.33 HP Power Exhaust	50	25	20
<sup>3</sup> Minimum Circuit Ampacity (MCA)	Unit Only	44	21	16
	With (1) 0.33 HP Power Exhaust	46	22	17

NOTE - All units have a minimum Short Circuit Current Rating (SCCR) of 5000 amps.

<sup>1</sup> Extremes of operating range are plus and minus 10% of line voltage.<sup>2</sup> HACR type breaker or fuse.<sup>3</sup> Refer to National or Canadian Electrical Code manual to determine wire, fuse and disconnect size requirements.

**ELECTRICAL DATA****10 TON**

<b>Model No.</b>		<b>LGM120U4E/ LGM120U4P</b>		
<b><sup>1</sup> Voltage - 60Hz</b>		<b>208/230V-3ph</b>	<b>460V-3ph</b>	<b>575V-3ph</b>
Compressor 1	Rated Load Amps	13.5	6.3	5
	Locked Rotor Amps	21	11	12
Compressor 2	Rated Load Amps	16	7.8	5.7
	Locked Rotor Amps	110	52	38.9
Outdoor Fan Motors (2)	Full Load Amps (total)	2.8 (5.6)	1.4 (2.8)	1.1 (2.2)
Power Exhaust (1) 0.33 HP	Full Load Amps	2.4	1.3	1
Service Outlet 115V GFI (amps)		15	15	20
Indoor Blower Motor	Horsepower	3.75	3.75	3.75
	Full Load Amps	8.8	4.3	3.4
<sup>2</sup> Maximum Overcurrent Protection (MOCP)	Unit Only	60	30	20
	With (1) 0.33 HP Power Exhaust	60	30	20
<sup>3</sup> Minimum Circuit Ampacity (MCA)	Unit Only	48	24	18
	With (1) 0.33 HP Power Exhaust	51	25	19

NOTE - All units have a minimum Short Circuit Current Rating (SCCR) of 5000 amps.

<sup>1</sup> Extremes of operating range are plus and minus 10% of line voltage.<sup>2</sup> HACR type breaker or fuse.<sup>3</sup> Refer to National or Canadian Electrical Code manual to determine wire, fuse and disconnect size requirements.**ELECTRICAL DATA****12.5 TON**

<b>Model No.</b>		<b>LGM150U4E/ LGM150U4P</b>		
<b><sup>1</sup> Voltage - 60Hz</b>		<b>208/230V-3ph</b>	<b>460V-3ph</b>	<b>575V-3ph</b>
Compressor 1	Rated Load Amps	16.4	7.7	6.2
	Locked Rotor Amps	21	11	12
Compressor 2	Rated Load Amps	19.6	8.2	7.7
	Locked Rotor Amps	136	66.1	54
Outdoor Fan Motors (2)	Full Load Amps (total)	2.8 (5.6)	1.4 (2.8)	1.1 (2.2)
Power Exhaust (1) 0.33 HP	Full Load Amps	2.4	1.3	1
Service Outlet 115V GFI (amps)		15	15	20
Indoor Blower Motor	Horsepower	3.75	3.75	3.75
	Full Load Amps	8.8	4.3	3.4
<sup>2</sup> Maximum Overcurrent Protection (MOCP)	Unit Only	70	30	25
	With (1) 0.33 HP Power Exhaust	70	30	30
<sup>3</sup> Minimum Circuit Ampacity (MCA)	Unit Only	56	26	22
	With (1) 0.33 HP Power Exhaust	58	27	23

NOTE - All units have a minimum Short Circuit Current Rating (SCCR) of 5000 amps.

<sup>1</sup> Extremes of operating range are plus and minus 10% of line voltage.<sup>2</sup> HACR type breaker or fuse.<sup>3</sup> Refer to National or Canadian Electrical Code manual to determine wire, fuse and disconnect size requirements.

## UNIT CLEARANCES

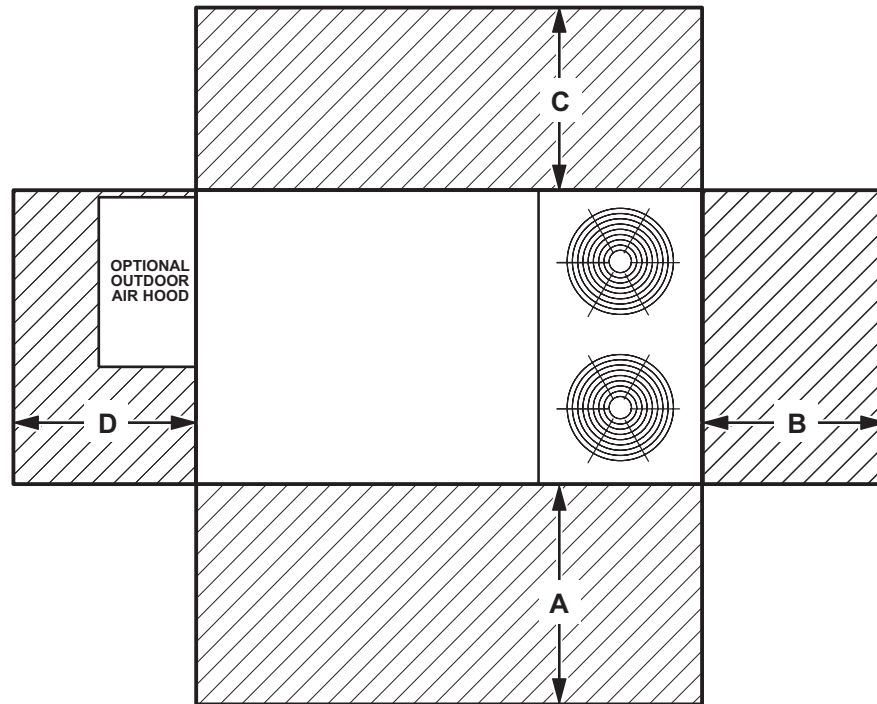

<sup>1</sup> Unit Clearance	A		B		C		D		Top Clearance
	in.	mm	in.	mm	in.	mm	in.	mm	
<b>Service Clearance</b>	60	1524	36	914	36	934	60	1524	Unobstructed
<b>Clearance to Combustibles</b>	36	914	1	25	1	25	1	25	
<b>Minimum Operation Clearance</b>	36	914	36	914	36	914	36	914	

NOTE - Entire perimeter of unit base requires support when elevated above the mounting surface.

<sup>1</sup> Service Clearance - Required for removal of serviceable parts.

Clearance to Combustibles - Required clearance to combustible material.

Minimum Operation Clearance - Required clearance for proper unit operation.

## OUTDOOR SOUND DATA

Unit Model Number	Octave Band Sound Power Levels dBA, re 10 <sup>-12</sup> Watts - Center Frequency - Hz							<sup>1</sup> Sound Rating Number (dBA)
	125	250	500	1000	2000	4000	8000	
092-102 Min.	58	62	62	60	55	47	60	68
092-102 Max.	72	77	81	79	74	68	66	85
120-150 Min.	55	60	62	60	56	48	60	67
120-150 Max.	79	78	85	83	79	76	73	89

Note - The octave sound power data does not include tonal corrections.

<sup>1</sup> Sound Rating Number according to AHRI Standard 370-2001 (includes pure tone penalty).

Sound Rating Number is the overall A-Weighted Sound Power Level (LWA), dBA (100 Hz to 10,000 Hz).

<b>WEIGHT DATA</b>				<b>UNIT</b>
<b>Model Number</b>	<b>Net</b>		<b>Shipping</b>	
	<b>lbs.</b>	<b>kg</b>	<b>lbs.</b>	<b>kg</b>
092 Base Unit	1168	530	1253	568
092 Max. Unit	1319	598	1404	637
102 Base Unit	1175	533	1260	572
102 Max. Unit	1326	601	1411	640
120 Base Unit	1210	549	1295	587
120 Max. Unit	1361	617	1446	656
150 Base Unit	1226	556	1311	595
150 Max. Unit	1377	625	1462	663

<b>WEIGHT DATA</b>		<b>OPTIONS / ACCESSORIES</b>	
<b>Model Number</b>	<b>Shipping Weight</b>		
	<b>lbs.</b>	<b>kg</b>	
<b>ECONOMIZER / OUTDOOR AIR / EXHAUST</b>			
<b>Economizer</b>			
Economizer Dampers	60	27	
Outdoor Air Hood (downflow)	23	10	
Barometric Relief Dampers (downflow)	8	4	
Barometric Relief Dampers (low profile horizontal)	20	9	
<b>Outdoor Air Dampers</b>			
Outdoor Air Damper Section - Automatic	51	23	
Outdoor Air Damper Section - Manual	39	18	
<b>Power Exhaust</b>	31	14	
<b>GAS HEAT EXCHANGER (NET WEIGHT)</b>			
Medium Heat (adder over standard heat)	9	5	
High Heat (adder over standard heat)	32	15	
<b>HUMIDITROL™+ HOT GAS REHEAT SYSTEM</b>			
Humiditrol™+ Dehumidification Option	20	9	
<b>ROOF CURBS</b>			
<b>Hybrid Roof Curbs, Downflow</b>			
8 in. height	60	27	
14 in. height	85	39	
18 in. height	100	45	
24 in. height	125	57	
<b>Adjustable Pitch Curb, Downflow</b>			
14 in. height	191	82	
<b>CEILING DIFFUSERS</b>			
<b>Step-Down</b>			
	RTD11-95S	118	54
	RTD11-135S	135	61
	RTD11-185S	168	76
<b>Flush</b>			
	FD11-95S	118	54
	FD11-135S	135	61
	FD11-185S	168	76
<b>Transitions</b>			
	C1DIFF30B-1	30	14
	C1DIFF31B-1	32	15
	C1DIFF32B-1	36	16
<b>PACKAGING</b>			
LTL Packaging (less than truck load)		105	48



# DIMENSIONS

# UNIT

Model No.	CORNER WEIGHTS												CENTER OF GRAVITY											
	AA				BB				CC				DD				EE				FF			
	Base		Max.		Base		Max.		Base		Max.		Base		Max.		Base		Max.		Base		Max.	
	lbs.	kg	lbs.	kg	lbs.	kg	lbs.	kg	lbs.	kg	lbs.	kg	lbs.	kg	lbs.	kg	in.	mm	in.	mm	in.	mm	in.	mm
092	293	133	338	153	263	119	295	134	286	130	316	143	326	148	370	168	46.5	1181	45.5	1156	24.5	622	25.5	648
102	294	134	340	154	265	120	297	135	288	131	318	144	328	149	372	169	46.5	1181	45.5	1156	24.5	622	25.5	648
120	306	139	349	158	275	125	305	138	295	134	326	148	334	152	382	173	46.5	1181	45.5	1156	24.5	622	25.5	648
150	316	143	359	163	284	129	314	142	304	138	393	178	345	157	393	178	46.5	1181	45.5	1156	24.5	622	25.5	648

Base Unit - The unit with NO INTERNAL OPTIONS.

Max. Unit - The unit with ALL INTERNAL OPTIONS Installed. (Economizer, Standard Static Power Exhaust Fans, Controls, etc.). Does not include accessories external to unit or high static power exhaust.

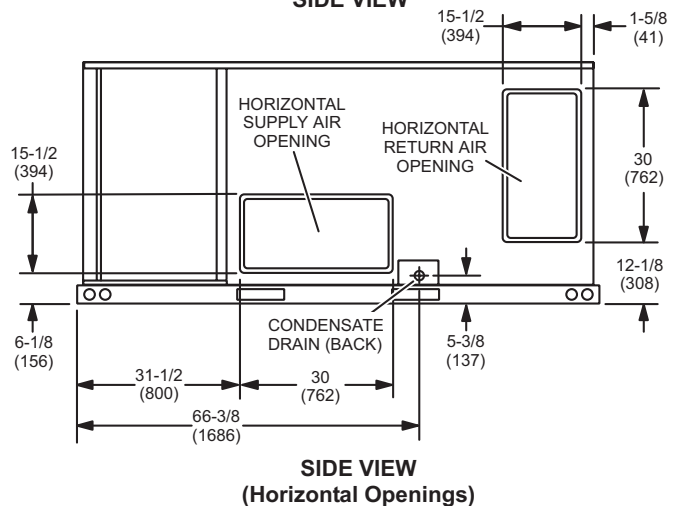
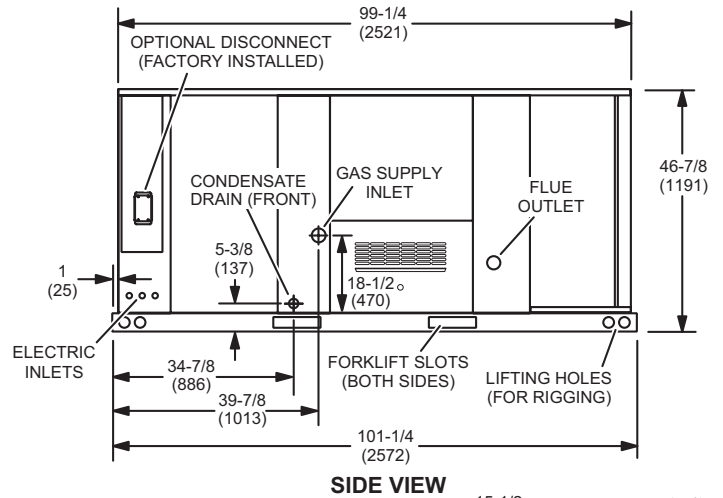
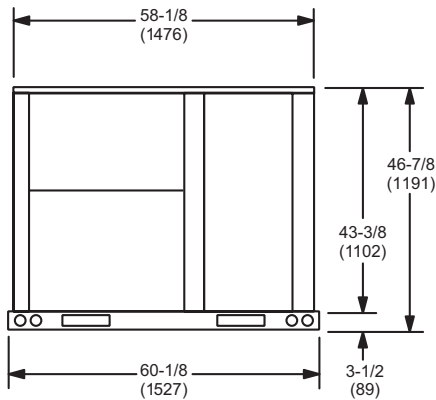
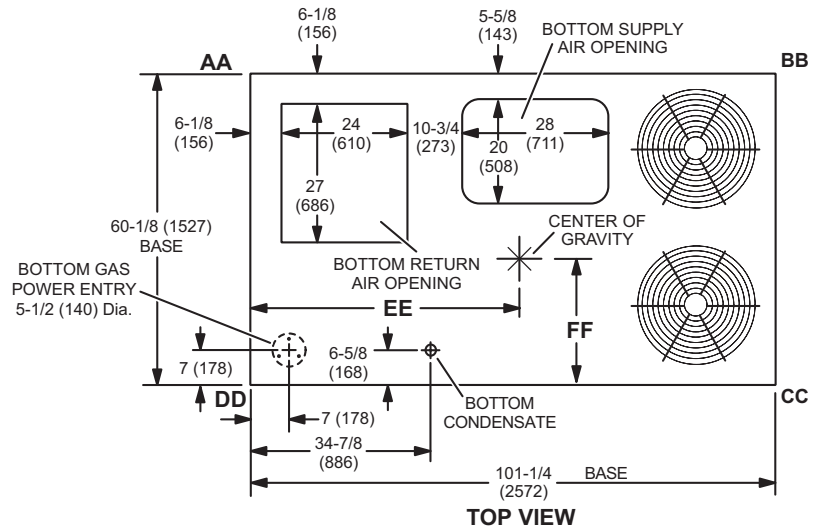

### OUTDOOR AIR HOOD DETAIL

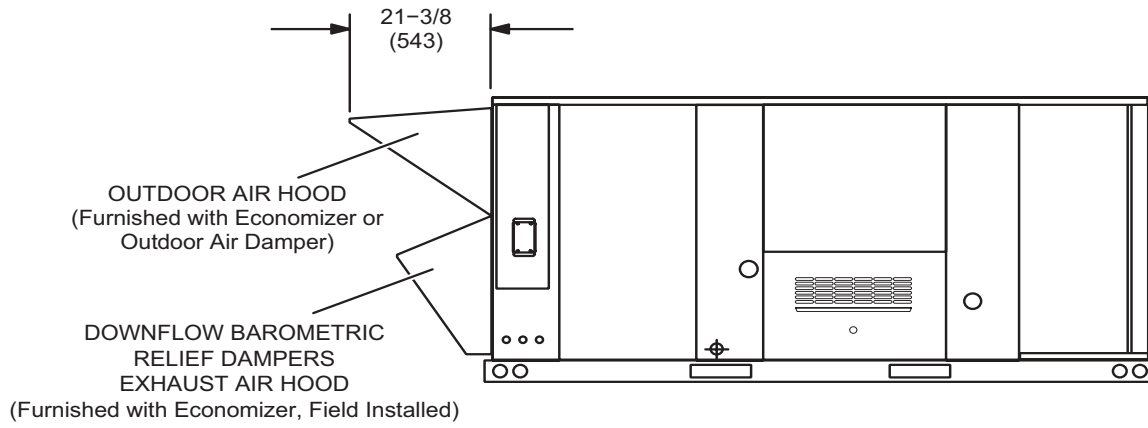

**HORIZONTAL ECONOMIZER APPLICATION**

(With Furnished Barometric Relief Dampers and Optional Horizontal Discharge Kit - Required)

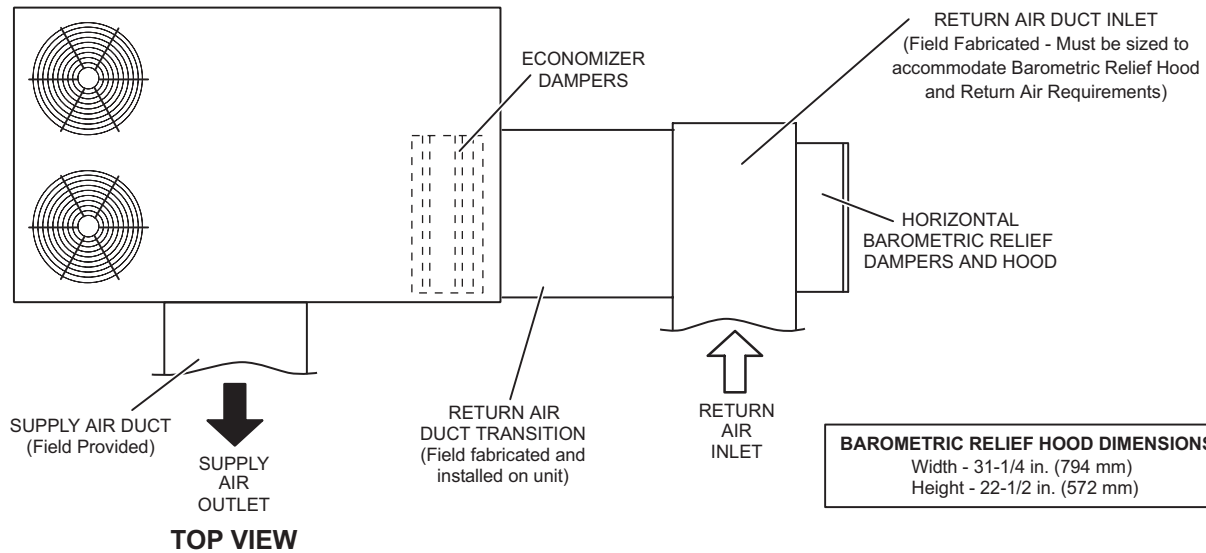

**TOP VIEW**

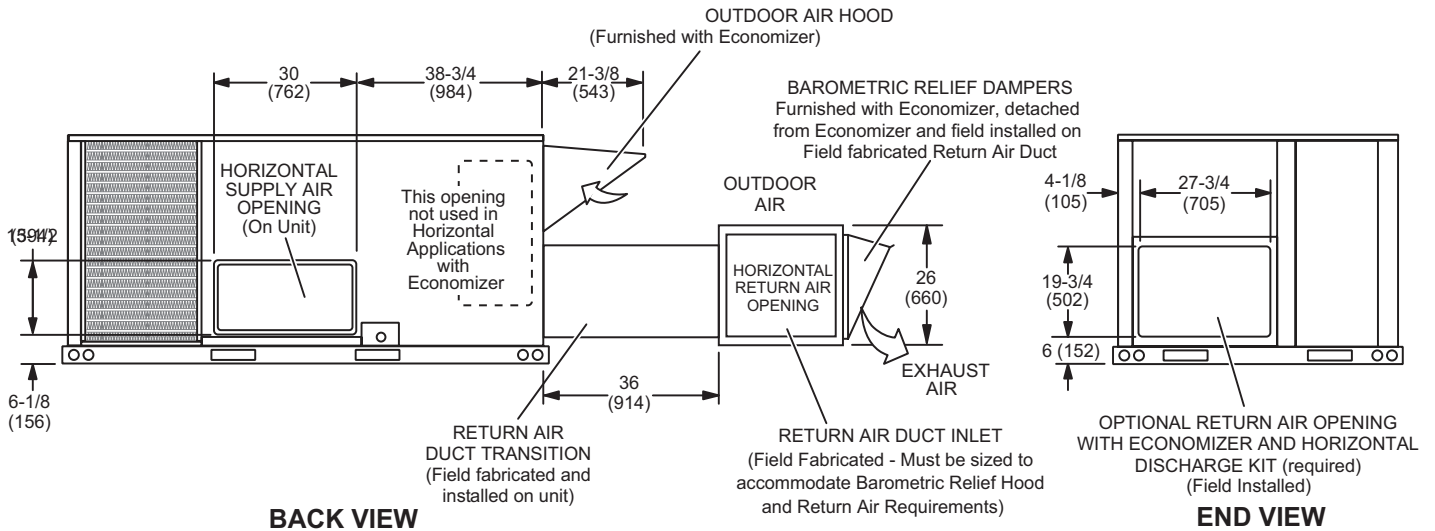

**BACK VIEW**

**END VIEW**

**NOTE** - Return Air Duct and Transition must be supported.

**BAROMETRIC RELIEF DAMPERS  
(Furnished with Economizer)**

(Field installed in horizontal return air duct adjacent to unit)

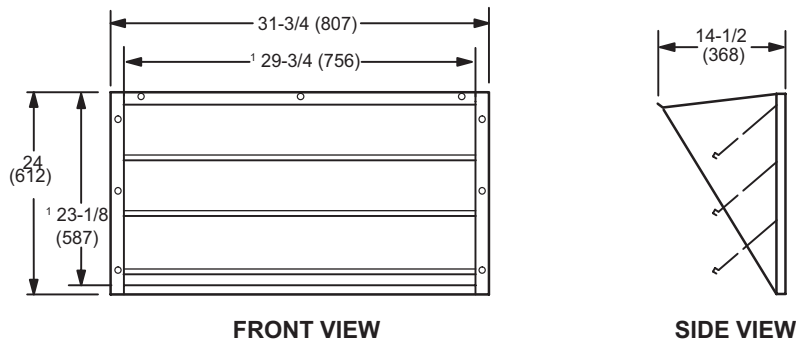

**FRONT VIEW**

**SIDE VIEW**

<sup>1</sup> NOTE - Opening size required in return air duct.

**HORIZONTAL ECONOMIZER APPLICATION**

(with Optional Low Profile Horizontal Barometric Relief Dampers and Horizontal Discharge Kit - Required)

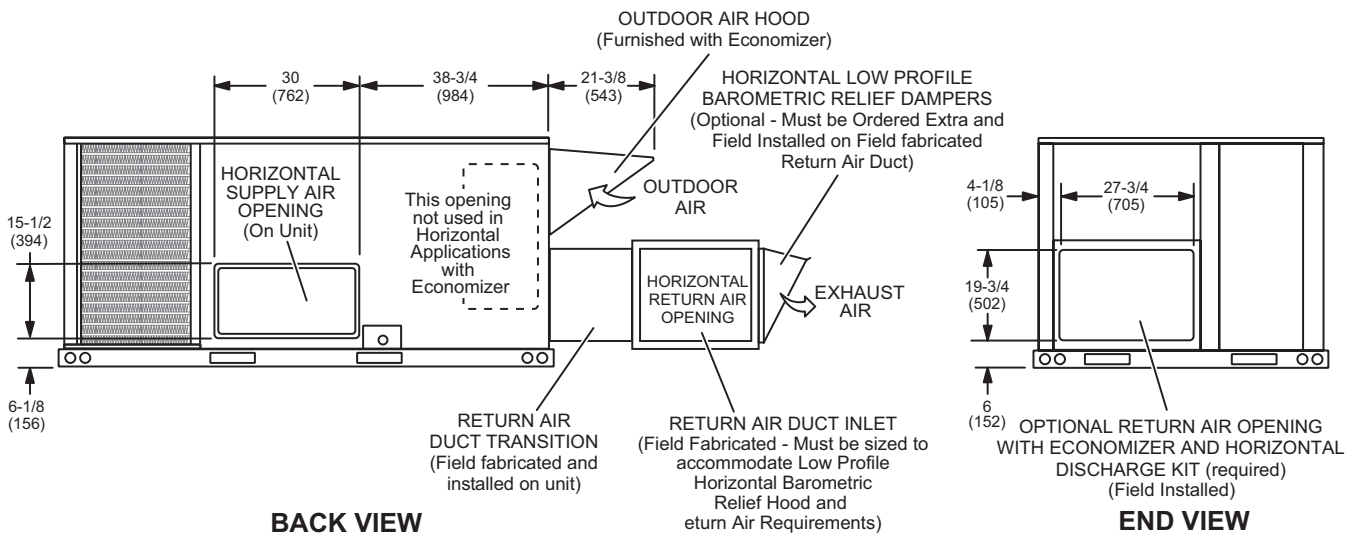
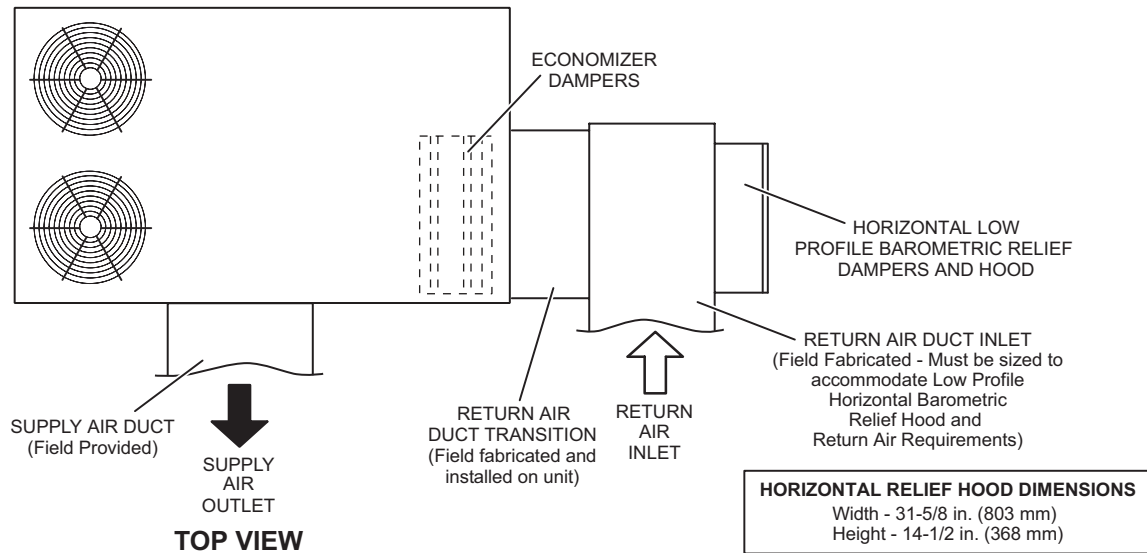

**NOTE** - Return Air Duct and Transition must be supported.

**HORIZONTAL LOW PROFILE BAROMETRIC RELIEF DAMPERS**  
(Field installed in horizontal return air duct adjacent to unit)

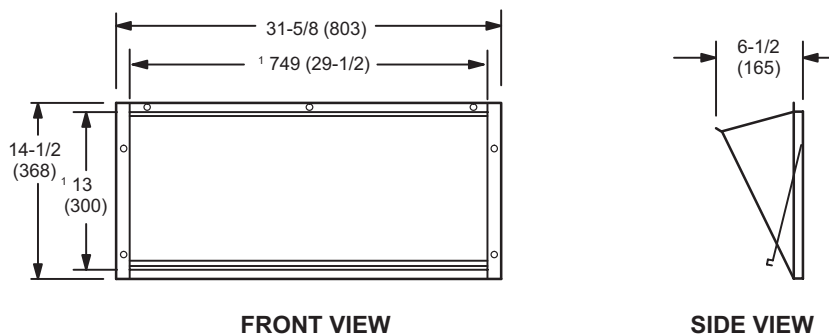

<sup>1</sup> NOTE - Opening size required in return air duct.

**HYBRID ROOF CURBS - DOUBLE DUCT OPENING**

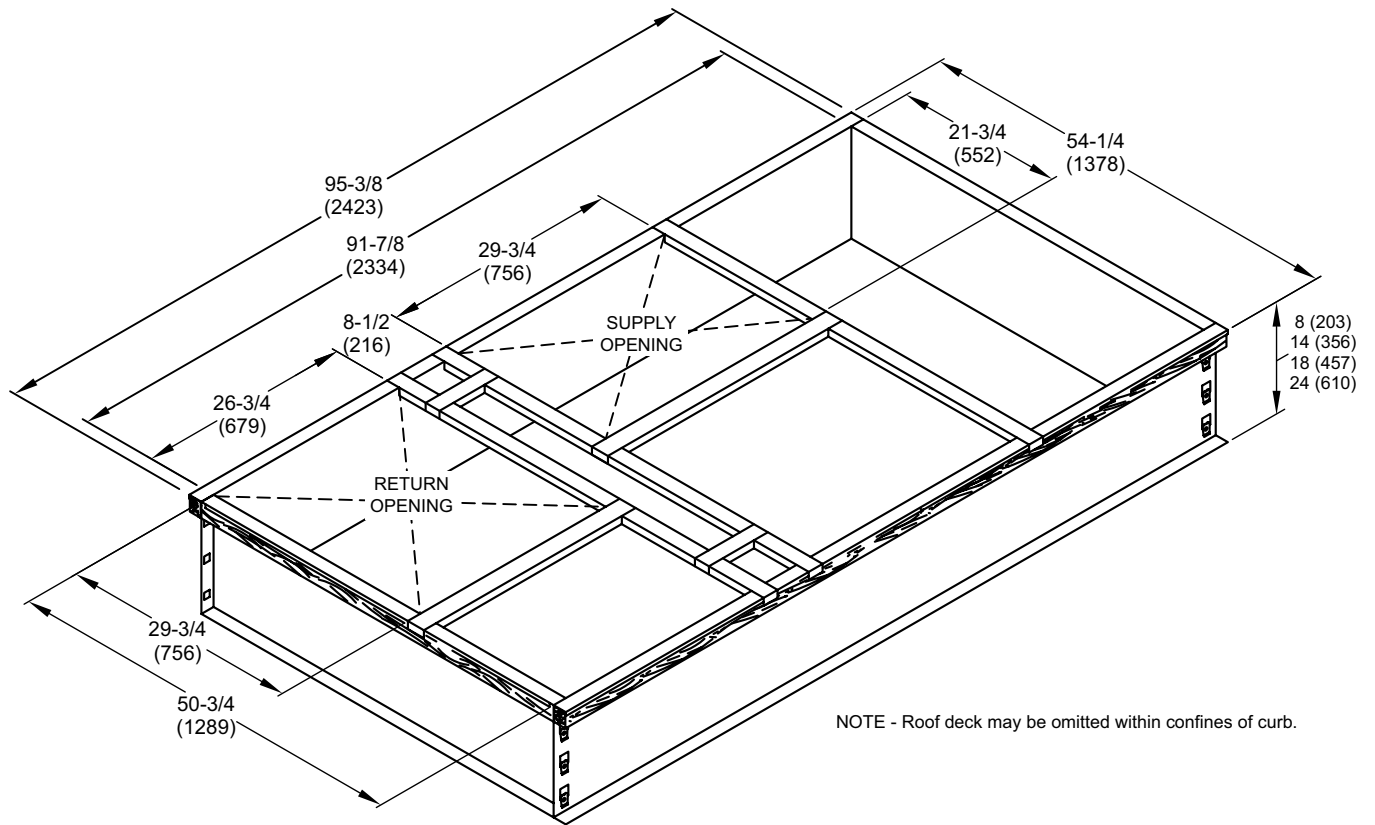

**TYPICAL FLASHING DETAIL FOR ROOF CURB**

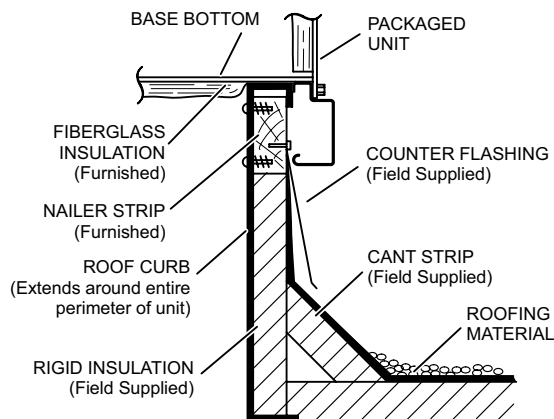

**DETAIL ROOF CURB**

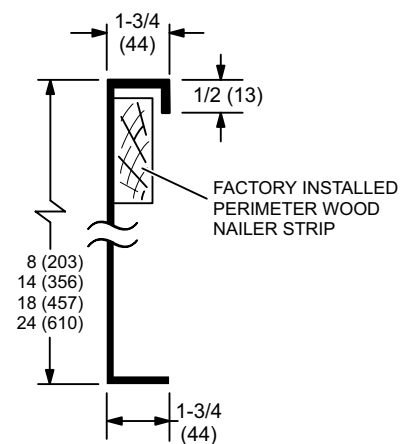

**ADJUSTABLE PITCH CURBS - DOUBLE DUCT OPENING**

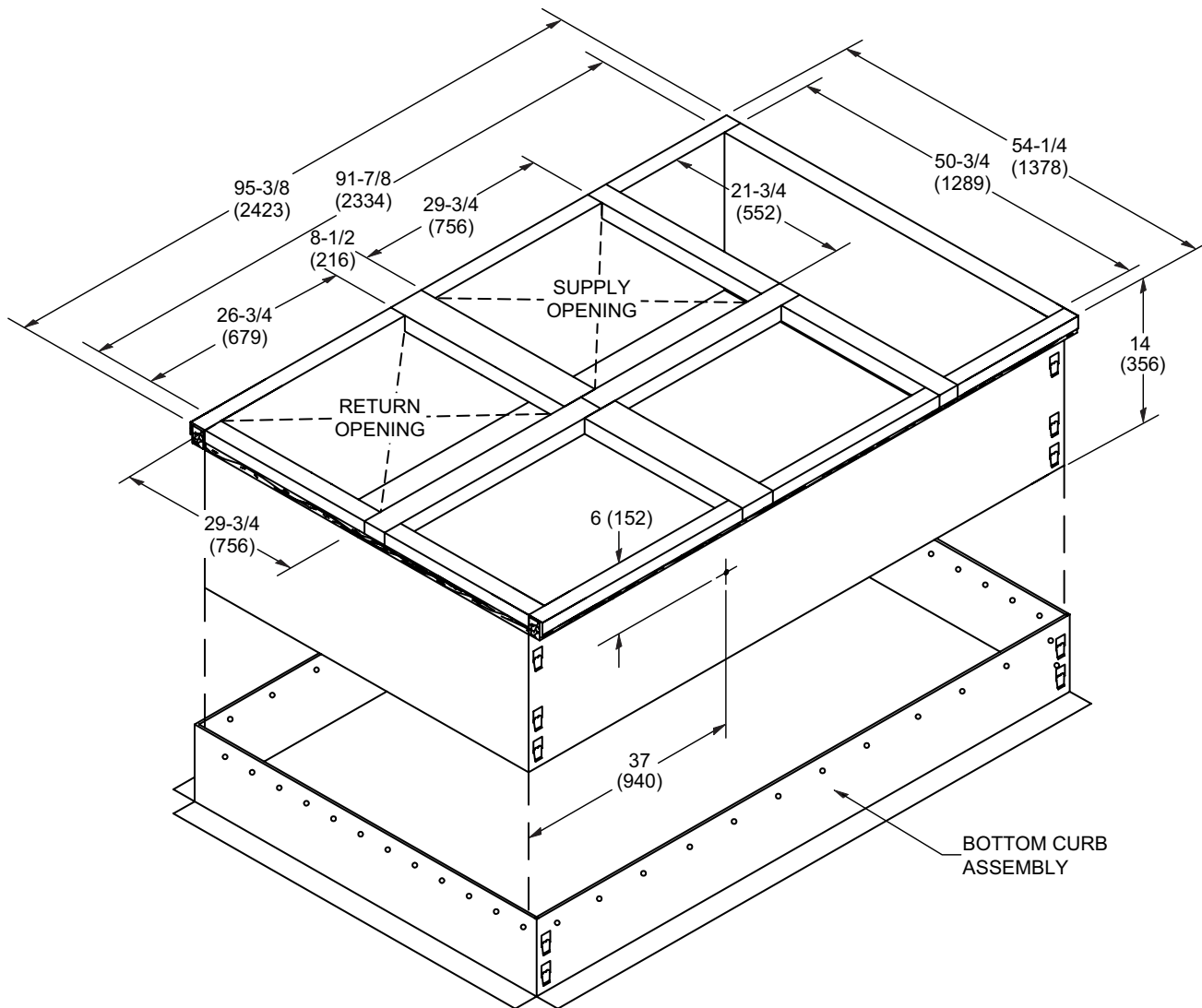

NOTE - Maximum slope pitch is 3/4 in. per 1 foot (19 mm per 305 mm) in any one direction.

**TYPICAL FLASHING DETAIL FOR ROOF CURB**

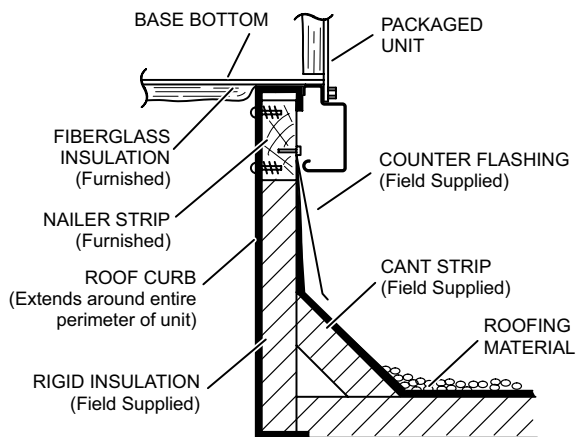

**DETAIL ROOF CURB**

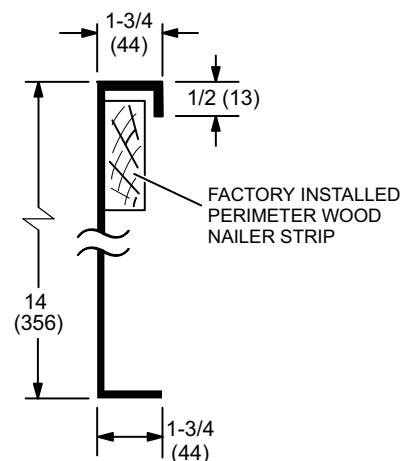

ROOF CURBS WITH SUPPLY & RETURN AIR TRANSITIONS FOR CEILING DIFFUSERS

**C1DIFF30B-1 ROUND TRANSITIONS**  
(for 092 models)

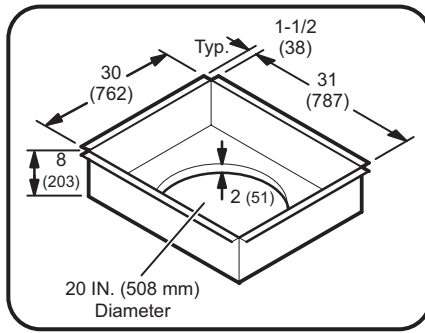

**C1DIFF31B-1 & C1DIFF32B-1 RECTANGULAR TRANSITIONS**  
(for 102 thru 150 models)

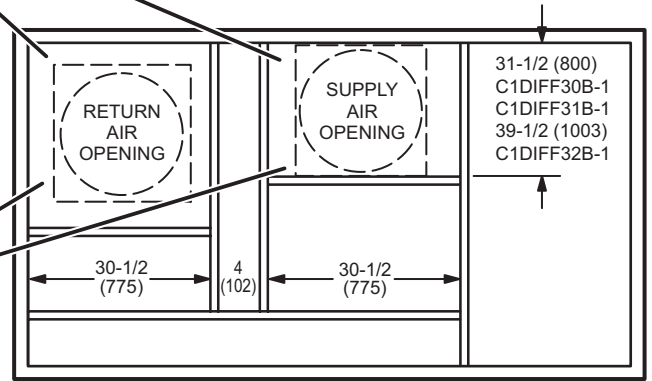
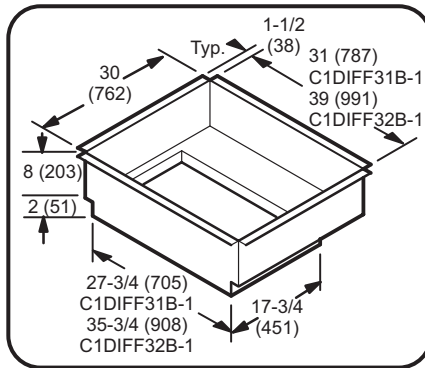

TOP VIEW

**COMBINATION CEILING SUPPLY AND RETURN DIFFUSERS**

**STEP-DOWN CEILING DIFFUSER**

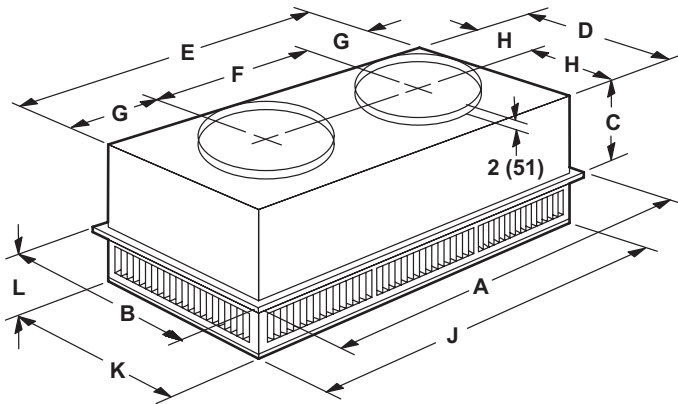

**FLUSH CEILING DIFFUSER**

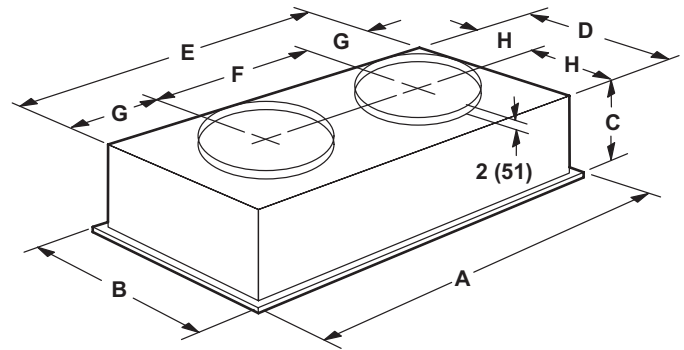

Model Number		RTD11-95S
A	in.	47-5/8
	mm	1159
B	in.	29-5/8
	mm	752
C	in.	14-3/8
	mm	365
D	in.	27-1/2
	mm	699
E	in.	45-1/2
	mm	1158
F	in.	22-1/2
	mm	572
G	in.	11-1/2
	mm	292
H	in.	13-3/4
	mm	349
J	in.	45-1/2
	mm	1156
K	in.	27-1/2
	mm	699
L	in.	8-1/8
	mm	206
Duct Size	in.	20 round
	mm	508 round

Model Number		FD11-95S
A	in.	47-5/8
	mm	1159
B	in.	29-5/8
	mm	752
C	in.	16-5/8
	mm	422
D	in.	27
	mm	686
E	in.	45
	mm	1143
F	in.	22-1/2
	mm	572
G	in.	11-1/4
	mm	286
H	in.	13-1/2
	mm	343
Duct Size	in.	20 round
	mm	508 round



**COMBINATION CEILING SUPPLY AND RETURN DIFFUSERS**  
**STEP-DOWN CEILING DIFFUSER**

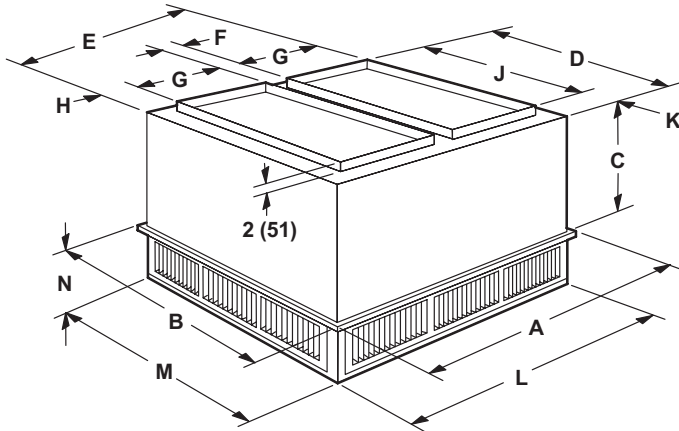

**FLUSH CEILING DIFFUSER**

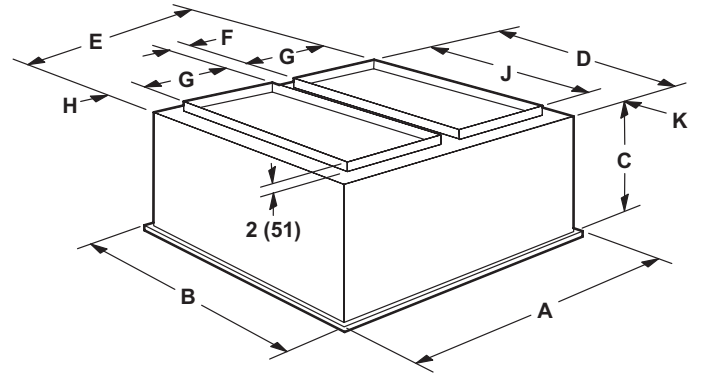

Model Number		RTD11-135S	RTD11-185S
A	in.	47-5/8	47-5/8
	mm	1210	1210
B	in.	35-5/8	47-5/8
	mm	905	1210
C	in.	20-5/8	24-5/8
	mm	524	625
D	in.	33-1/2	45-1/2
	mm	851	1156
E	in.	45-1/2	45-1/2
	mm	1156	1156
F	in.	4-1/2	4-1/2
	mm	114	114
G	in.	18	18
	mm	457	457
H	in.	2-1/2	2-1/2
	mm	64	64
J	in.	28	36
	mm	711	914
K	in.	2-3/4	4-3/4
	mm	70	121
L	in.	45-1/2	45-1/2
	mm	1156	1156
M	in.	33-1/2	45-1/2
	mm	851	1156
N	in.	9-1/8	10-1/8
	mm	232	257
Duct Size	in.	18 x 28	18 x 36
	mm	457 x 711	457 x 914

Model Number		FD11-135S	FD11-185S
A	in.	47-5/8	47-5/8
	mm	1210	1210
B	in.	35-5/8	47-5/8
	mm	905	1210
C	in.	23-1/4	29-1/4
	mm	591	743
D	in.	33	45
	mm	838	1143
E	in.	45	45
	mm	1143	1143
F	in.	4-1/2	4-1/2
	mm	114	114
G	in.	18	18
	mm	457	457
H	in.	2-1/4	2-1/4
	mm	57	57
J	in.	28	36
	mm	711	914
K	in.	2-1/2	4-1/2
	mm	64	114
Duct Size	in.	18 x 28	18 x 36
	mm	457 x 711	457 x 914

## REVISIONS

Section	Description
Approvals	Added Seismic Certification.
Document	Added 575V model specifications, ratings, electrical data and options.
Options/Accessories	Updated Combination Coil/Hail Guard usage for 092/102 models.



Intertek



**HRAI**  
✓ MEMBER COMPANY



Visit us at [www.Lennox.com](http://www.Lennox.com)

For the latest technical information, [www.LennoxCommercial.com](http://www.LennoxCommercial.com)

Contact us at 1-800-4-LENNOX

NOTE - Due to Lennox' ongoing commitment to quality, Specifications, Ratings and Dimensions subject to change without notice and without incurring liability. Improper installation, adjustment, alteration, service or maintenance can cause property damage or personal injury. Installation and service must be performed by a qualified installer and servicing agency.

©2021 Lennox Industries, Inc.