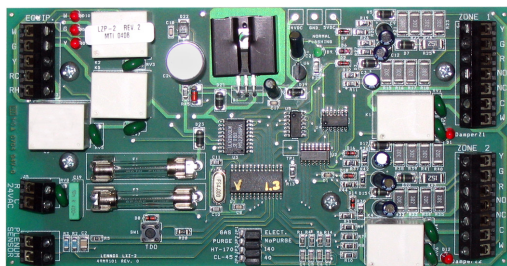

LENNOX**PRODUCT SPECIFICATIONS**

LZP-2 Zone Control Panel Board

**FEATURES****NOTE - NOT APPLICABLE TO HEAT PUMP SYSTEMS!****WARRANTY**

Zone Control Panel - Two year limited warranty in residential applications.

Refer to Lennox Equipment Limited Warranty certificate included with unit for specific details.

ZONE CONTROL SYSTEM

LZP-2 Zone Control Panel (**X3785**) is capable of controlling up to two separate zones.

The Panel is coupled with a single non-variable speed indoor unit (gas/oil) and a single stage air-conditioning unit.

Panel can be used with two-stage equipment when staging is controlled by the heating/cooling equipment.

System consists of the LZP-2 Zone Control Panel, discharge air sensor (furnished), field supplied duct mounted motorized zone dampers with a thermostat in each zone and a field supplied bypass damper.

Panel is powered by a separate stand-alone transformer.

Zone dampers are automatically controlled to supply air flow only to zones with a thermostat demand.

Individual air volumes for heating or cooling are available to each zone.

Round or rectangular dampers can be used.

Zoning system allows temperature setback in unoccupied areas while maintaining comfort in occupied areas.

Auto-changeover control from any zone thermostat.

Results in lower equipment costs by eliminating the need for two separate heating/cooling systems.

Compatible with standard heat/cool electronic thermostats (non-power robbing).

Not for use with variable-speed gas furnaces, heat pump systems or electro-mechanical thermostats.

SEQUENCE OF OPERATION

When Zone 1 thermostat calls for heating or cooling, Zone 1 damper(s) remains open while Zone 2 damper(s) closes. If Zone 2 calls for heating or cooling, the opposite occurs.

If both zone thermostats call for heating or cooling the dampers in both zones will open.

If zone thermostats are calling for both heating and cooling at the same time, the first zone calling is served. The other zone will be served 4 minutes after the first zone is satisfied or after trying to satisfy the demand for 20 minutes.

System will operate on automatic or manual heat/cool changeover depending on thermostat settings.

ZONE CONTROL PANEL

Microprocessor controlled panel contains all necessary relays and controls to operate the system.

Automatic reset in case of operation error or power failure.

Built-in time delay function (4 minutes) prevents short cycling of system.

3A fuse protects panel from shorts in the thermostat and damper field wiring. Spare 3A fuse included.

Cabinet and removable cover constructed of high impact plastic.

Holes for mounting are furnished and electrical inlets are provided in cabinet.

Dimensions (H x W x D): 5 x 10-1/2 x 2 in.

Shipping weight: 2 lbs.

Power requirements: 24VAC (18-30VAC).

Low Voltage Equipment Terminals

- Two zones (dampers) (NO, NC)
- Heating/Cooling equipment connections (W, G, Y, RC, RH)

FEATURES

ZONE CONTROL PANEL (continued)

Low Voltage Control Terminals

- Two zone thermostats / dampers (Y, G, R, C, W)
- Discharge air sensor

Setup Jumpers

- System Type (GAS / ELECT.)
- Purge Fan (PURGE / NO PURGE)
- Discharge Air Sensor Heat Limit (HT-160 / 140)
- Discharge Air Sensor Cooling Limit (CL-45 / 40)

Display LED's

- Damper Z1 (LED lit when Zone 1 damper is closed)
- Damper Z2 (LED lit when Zone 2 damper is closed)
- W (LED lit when output is on)
- Y (LED lit when output is on)
- G (Fan)
- Power (flashing)

Timer Delay Override Button (TDO)

- Speeds up onboard timer by a factor of 60 for system checkout.

ZONE CONTROL PANEL JUMPER SETTINGS

Purge / No Purge

Allows the fan to operate a 60 second purge time. Works in heat and cool mode. Set the switch to NO PURGE to allow the heating or cooling system to operate it's own fan purge. NO PURGE setting will hold the damper position for 210 seconds, PURGE setting will hold damper position for 60 seconds.

Gas / Elect.

Select GAS to control fan with gas/oil heating equipment. Select ELECT. when setting up for straight electric heating applications.

HT-160 / 140

Controls the heating temperature cut-out. 160°F for gas furnaces, 140°F for electric heat. Factory setting is 160°F.

CL-45 / 40

Controls the cooling temperature cut-out. Sets the low temperature limit (45°F or 40°F). Factory setting is 45°F (recommended for optimum operation).

Discharge Air Sensor (furnished)

Field installed in supply air plenum.

Senses discharge air temperature to control system based on low temperature and high temperature limit jumper settings on Zone Control Panel.

SYSTEM EQUIPMENT DATA

For furnace data, see Gas Furnaces or Oil Furnaces section.

For air handler data, see Air Handler section.

For air conditioner data, see Air Conditioners section.

For add-on indoor coil unit data, see Indoor Coils section.

Optional Accessories

CONTROLS

Transformer

24VAC transformer is required for operation of Zone Control Panel, thermostats and zone dampers.

Transformer size is determined by the total power requirements of the control panel, thermostats and damper.

See below for additional information.

NOTE - Zone Control Panel and Thermostats require 10VA
- Dampers require 10VA each

Catalog No.	Size	Description
10P17	40VA	120/208/240v - 24v
10P87	50VA	120/208/240v - 24v
12P61	75VA	120/208/240v - 24v
83P74	- - -	Electrical Box (4 in. sq.)

Zone Thermostats

Any single stage heating/cooling digital electronic thermostat with 24VAC common terminal may be used.

Also see Thermostat bulletins in Controls section and Lennox Price Book.

Recommended thermostats:

- ComfortSense® 5500 1 htg. / 1 clg. (**13H13**)
- ComfortSense® 3000 1 htg. / 1 clg. (**51M34**)

DAMPERS

Zone Dampers

Must be field supplied.

Any style 24VAC damper is compatible with the Zone Control Panel.

Spring Open / Power Close is the preferred type damper to use with this system.

At least one damper per zone is required.

Up to 5 dampers per zone may be connected in parallel to the Zone Control Panel - not to exceed a total of six dampers for entire system. If additional dampers are required, refer to the special wiring diagram in the installation instructions for additional information.

Bypass Damper

Bypass damper is required and must be field supplied. See Bypass Damper Sizing requirements on page 3.

TYPICAL SYSTEM LAYOUT

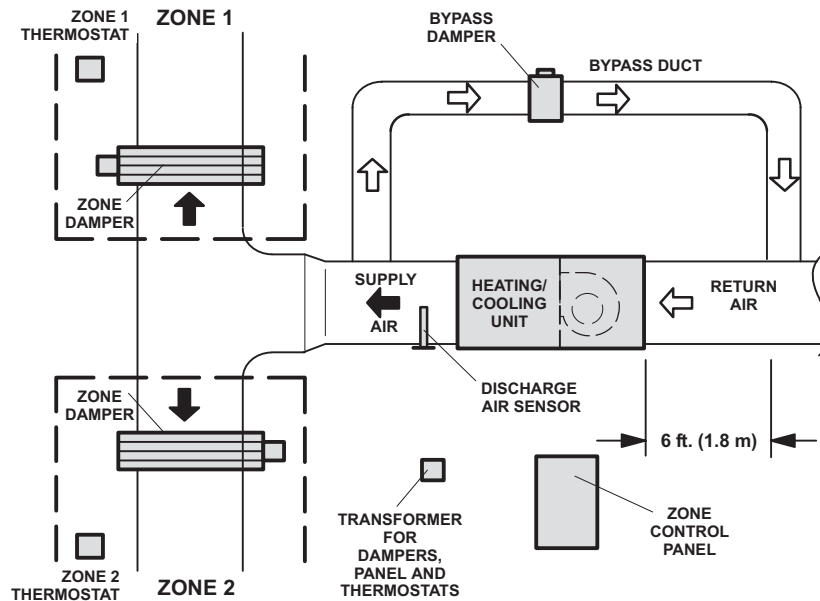

BYPASS DAMPER SIZING

- 100% of the rated air volume must always move through the duct work when zoning with high cooling demand areas. (i.e. Florida)
- Assume that the smallest zone will be the only one to have a demand at any given time.
- 65%-70% of the rated air volume should always move through the duct system with standard heating systems.
- If one zone is less than 15% of total air volume, consider more equally sizing the zones.
- Bypass damper method takes the excess pressure from the supply duct and sends it back to the return duct. This is done by tapping into the supply air and running a duct back to the return air and mounting a bypass damper in that run.
- When tapping back into the return duct, the tap should be a minimum of at least 6 ft. away from the equipment to insure that the hot or cold air coming off of the plenum has time to mix with the return air before going across the coil again. The Discharge Air Sensor (furnished) will prevent any damage to the equipment from overheating or coil freeze-up.
- The bypass should be sized to handle the excess pressure build-up for the smallest zone. This is the worst possible condition for the airflow and will cause the most excess pressure build-up. The calculation is done by taking the total air volume capacity of the smallest zone and subtracting it from the total air volume of the system.

Example:

Total System air volume: 2000 cfm
 Less smallest zone air volume: - 600 cfm
 Bypass amount: 1400 cfm

- The bypass duct would be sized to handle the 1400 cfm which would be the excess pressure when only the smallest zone has a demand. The bypass method must be used on zoning systems that will have unequal size zones and might be needed on some jobs that will have a smaller number of zones. This will be determined by the dealer at the time of installation. For bypass damper air volume capacities see the chart below.

Round	Rectangular
8 in. dia. - 400 cfm	12 x 8 - 1000 cfm
10 in. dia. - 750 cfm	12 x 10 - 1200 cfm
12 in. dia. - 1200 cfm	12 x 12 - 1400 cfm
14 in. dia. - 1800 cfm	20 x 8 - 1600 cfm
16 in. dia. - 2400 cfm	20 x 10 - 2000 cfm
	20 x 12 - 3000 cfm

FIELD WIRING

SHOWN WITH TYPICAL SINGLE STAGE FURNACE AND AIR CONDITIONER APPLICATION

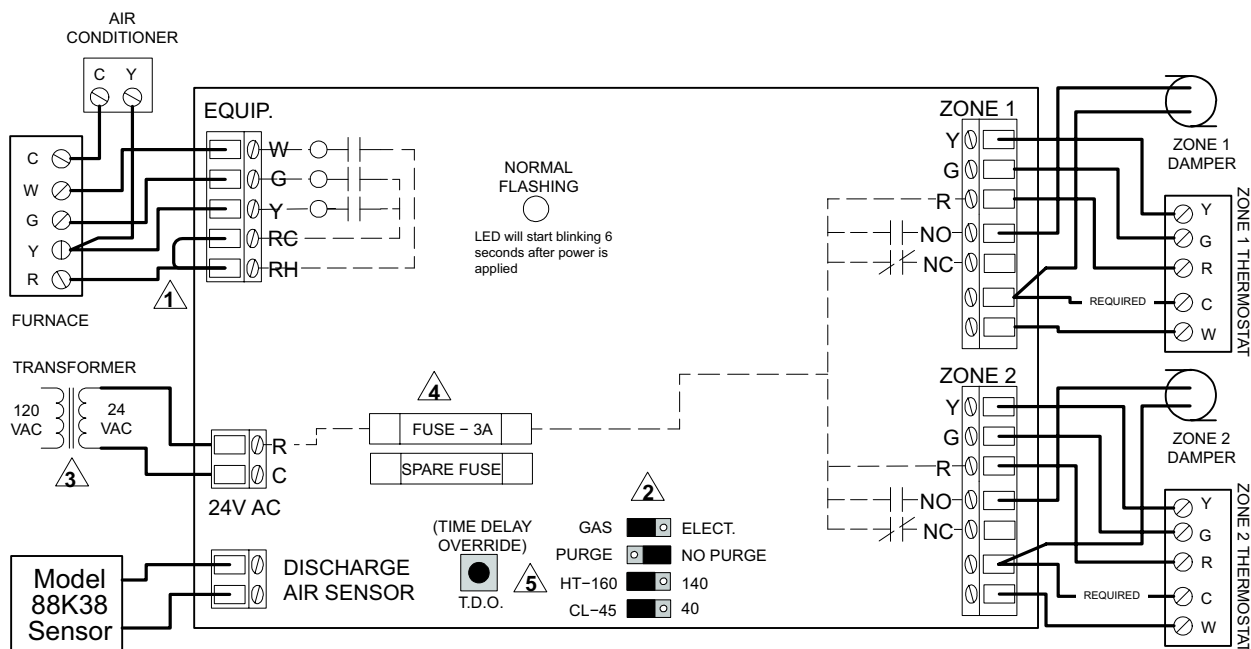

IMPORTANT! FOR SYSTEMS WITH AUTOMATIC CHANGEOVER THERMOSTATS YOU MAY WISH TO INSTALL COMPRESSOR PROTECTION TO PREVENT A/C OPERATION DURING COLD OUTDOOR AIR CONDITIONS.

CAUTION: CONNECT TO 24VAC ONLY. DISCONNECT POWER BEFORE SERVICING. FAILURE TO COMPLY MAY RESULT IN PERMANENT DAMAGE TO CONTROL PANEL.

CONTROL PANEL TERMINAL DESIGNATIONS

R 24V(hot) THERMOSTAT VOLTAGE
C 24V(com) T-STAT(req'd) & DAMPER VOLTAGE
W HEAT (Thermostats & Equipment)
Y COOLING (Thermostats & Equipment)
G FAN (Thermostats & Equipment)
NC NORMALLY CLOSED DAMPER OUTPUT
NO NORMALLY OPEN DAMPER OUTPUT
RH HEATING TRANSFORMER - 24V(hot)
RC COOLING TRANSFORMER - 24V(hot)
24VAC VOLTAGE SOURCE FOR CONTROL PANEL, T-STATS AND DAMPERS

- 1 If the heating and cooling system has a single transformer, install a jumper between **RH** and **RC**.
- 2 **ELECTRIC** position causes the equipment **G** terminal to energize with **W** on a call for heat (available for electric heat systems).
PURGE position allows zone control panel to control a 60 second purge cycle at the end of a cooling or electric heat call.
NO PURGE allows equipment control of purge cycle.
HT-160 or **140** controls the temperature at which the heating equipment will cut out to prevent overheating.
CL-45 or **40** controls the temperature at which the cooling equipment will cut out to prevent freezing.
- 3 A total of 6 dampers can be powered through the control panel at one time. Do not use the heating or cooling system transformer to power the control panel.
- 4 The **3 amp, slow blow fuse** protects the control panel, thermostat and damper circuits. It does not protect the Equipment Outputs.
- 5 Pressing the T.D.O. button speeds up the control panel's internal clock to bypass built-in time delays.
- 6 Discharge Air Sensor must be installed, or control panel will only respond to Zone 1 and will not position dampers.

NOTE - All wiring 18 gauge minimum. Must conform to NEC or CEC and local electrical codes.

REVISIONS

Sections	Description of Change
Optional Accessories	Revised recommended zone thermostats.



Visit us at www.lennox.com

For the latest technical information, www.lennox.com

Contact us at 1-800-4-LENNOX

NOTE - Due to Lennox' ongoing commitment to quality, Specifications, Ratings and Dimensions subject to change without notice and without incurring liability. Improper installation, adjustment, alteration, service or maintenance can cause property damage or personal injury. Installation and service must be performed by a qualified installer and servicing agency.

©2015 Lennox Industries, Inc.