



**GAS FURNACES**

**ML193UH**

**MERIT® SERIES**

**Upflow / Horizontal**

**PRODUCT SPECIFICATIONS**

Bulletin No. 210588

March 2019

Supersedes September 2018



**MERIT®  
SERIES**

**AFUE - 93%**

**Input - 44,000 to 132,000 Btuh**

**Nominal Add-on Cooling - 2 to 5 Tons**

**MODEL NUMBER IDENTIFICATION**

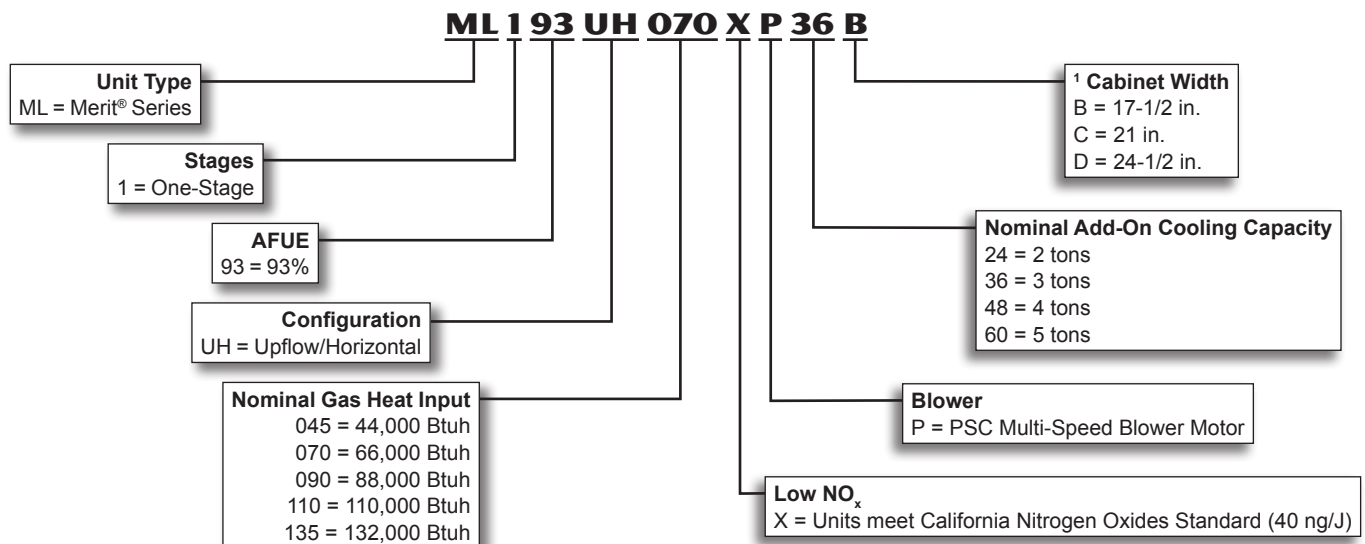

<sup>1</sup> Indoor coils with the same letter designation will physically match the furnace.

## FEATURES

### CONTENTS

Blower Data .....	20
Dimensions - Furnace/Coil Combined Dimensions ...	16
Dimensions - Horizontal Position .....	14
Dimensions - Upflow Position .....	13
Features .....	2
Gas Heat Accessories .....	10
High Altitude Derate .....	11
Installation Clearances .....	9
Model Number Identification .....	1
Optional Accessories - Order Separately .....	10
Optional Accessory Dimensions .....	15
Specifications .....	8
Vent Lengths .....	12

### WARRANTY

**Duralok Plus™ Aluminized Steel Heat Exchanger** - Limited twenty year warranty in residential applications, ten years in non-residential applications.

**All other covered components** - Limited five year warranty in residential applications, one year in non-residential applications.

Refer to Lennox Equipment Limited Warranty certificate included with equipment for details.

### APPROVALS

Units are certified by AHRI

Units tested and rated according to US DOE test procedures and FTC labeling regulations.

Blower data from unit tests conducted in Lennox Laboratory air test chamber.

Approved by the California Energy Commission and meets California Nitrogen Oxides Standard (NO<sub>x</sub>) limits of 40 ng/J.

ISO 9001 Registered Manufacturing Quality System.

#### California Only

If installed in South Coast Air Quality Management District (SCAQMD) only:

This furnace does not meet the SCAQMD Rule 1111 NO<sub>x</sub> emission limit (14 ng/J), and thus is subject to a mitigation fee of up to \$450. This furnace is not eligible for the Clean Air Furnace Rebate Program:

[www.CleanAirFurnaceRebate.com](http://www.CleanAirFurnaceRebate.com).

If installed in San Joaquin Valley Air Pollution Control District (SJVAPCD) only:

This furnace does not meet the SJVAPCD Rule 4905 NO<sub>x</sub> emission limit (14 ng/J), and thus is subject to a mitigation fee of up to \$450.

### APPLICATIONS

Input capacities of 44,000, 66,000, 88,000, 110,000 and 132,000 Btuh.

Energy efficiency (AFUE) of 93%.

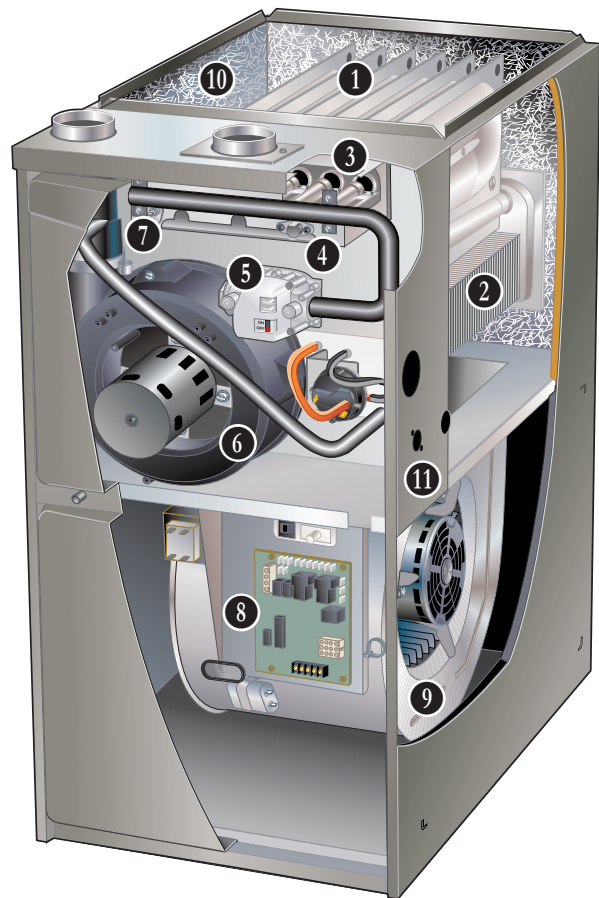

Compact cabinet for upflow, horizontal-left or horizontal-right applications without any modifications. Removable bottom seal panel shipped in place for side return air is easily removed for bottom/end return air applications.

Utility room, alcove, closet, crawl space, basement or attic installation.

Lennox add-on indoor coils, high-efficiency air cleaners and humidifiers can easily be added to furnace.

Shipped factory assembled with all controls installed and wired.

Each unit factory test operated to ensure proper operation.

### HEATING SYSTEM

#### 1 Lennox Duralok Plus™ Heat Exchanger Assembly

Lennox developed heat exchanger assembly consists of primary heat exchanger and secondary condenser coil assembly.

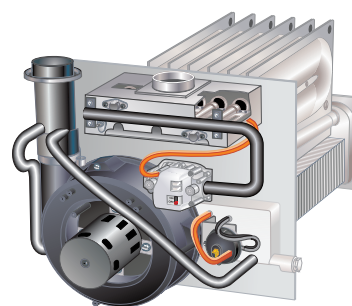

Main multi-pass crimped seam design clamshell type heat exchanger.

Constructed of heavy-gauge, aluminized steel.

Designed for normal expansion and contraction

with maximum efficiency and minimum resistance to air flow.

## FEATURES

### HEATING SYSTEM (continued)

- 2 Secondary heat exchanger condenser coil constructed of aluminum fins fitted to stainless steel tubes. Coil is factory tested for leaks. Condensate drain header box assembly located on front of coil. Compact size of complete heat exchanger assembly permits low overall design of furnace cabinet. Heat exchanger assembly has been laboratory life cycle tested in excess of industry standards.

#### Lennox Designed Header Box

Header box on end of condenser coil collects flue condensate for disposal through condensate drains. The drains are located on each side of the cabinet for easy field installation of condensate drain trap. Only one drain is used, the other drain is sealed. Condensate drain trap is included with the unit for field installation.

#### Lennox Designed Flue Condensate Trap Assembly

Condensate trap assembly is mounted outside the conditioned air stream. Assembly can be mounted on either side of cabinet in upflow applications. Assembly is mounted below the cabinet in horizontal applications. Can also be mounted remotely (up to 5 ft. away) from unit. See Dimension Drawing and Installation Instructions. 90° street elbow furnished for ease of drain trap installation. Drain connection can be made with field provided PVC pipe or PVC coupling. Drain cap on trap allows easy cleaning and winterizing.

- 3 **Inshot Burners**  
Aluminized steel inshot burners provide efficient, trouble-free operation. Burner venturi mixes air and gas in correct proportion for proper combustion. Burner assembly is removable from the unit as a single component for ease of service.
- 4 **SureLight® Integrated Furnace Control**  
Tough, reliable, long-life, trouble-free performance. Silicon nitride ignitor. Cemented to steatite block for protection against current leakage. Ignition leads are constructed of nickel plated copper and are enclosed in high temperature Teflon® insulation for dependable operation.
- 5 **Gas Control Valve**  
24 volt redundant combination gas control valve combines manual shut off switch (On-Off), automatic electric valve (dual) and gas pressure regulation into a compact combination control.

- 6 **Combustion Air Inducer**  
Shaded pole heavy duty blower prepurges heat exchanger and safely vents flue products. Operates only during heating cycle.

#### Pressure Switch

Proves Combustion Air Inducer operation before allowing gas valve to open.

#### Limit Control

Automatic reset, primary limit is accurately located on header box on all units.

- 7 **Flame Rollout Switches (2)**  
Manual reset switches are factory installed on the front of the burner box. Switch provides protection from abnormal operating conditions.

### Optional Accessories

#### 36K Derate Kit (045 models only)

Allows 045 (44K input) models input to be reduced to 36K. For use with natural gas only.

#### High Altitude Orifice Kits

Required on all units for proper operation at altitudes from 7501 to 10,000 ft. Kits are available for natural gas and LPG/propane.

#### High Altitude Pressure Switch Kit

Required for proper unit operation on installations above 4500 ft.

#### Natural Gas to LPG/Propane Conversion Kit

Required for field changeover from natural gas to LPG/Propane.

#### LPG/Propane to Natural Gas Conversion Kit

Required for field changeover from LPG/Propane to natural gas.

#### Muffler (US Only)

Significantly reduces outdoor operating sound levels. Two-inch diameter muffler is optional for 045 through 110 input models.

*NOTE - Two-inch muffler is optional for the 110 input model with a maximum vent pipe length of up to 29 ft.*

Three-inch diameter muffler is optional for 110 and 135 input models.

*NOTE - Three-inch muffler is optional for the 110 input model with a minimum vent pipe length of 30 ft.*

Installed vertically in the exhaust piping.

See Optional Accessory Dimension Drawing.

## FEATURES

### **DIRECT VENT / NON-DIRECT VENT SEALED COMBUSTION SYSTEM**

Furnace features a “sealed combustion” system and can be installed in either Direct Vent or Non-Direct applications.

In Direct Vent applications, combustion air is supplied from outdoors and flue gases are discharged outdoors.

In Non-Direct Vent applications, combustion air is supplied from indoors and flue gases are discharged outdoors.

*NOTE - Lennox has approved the use of DuraVent® PolyPro® and Centrotherm InnoFlue® manufactured vent pipe and terminations as an alternative to PVC vent pipe. Must be ordered separately.*

*Tested and listed to the ULC S636 standard in Canada.*

*The polypropylene venting system must follow the uninsulated and unconditioned space vent lengths listed in the table on Page 4.*

*Refer to the Installation Instructions for additional details.*

### **Optional Accessories**

#### **Flue Coupling**

Assists with exhaust flue piping connection and servicing.

Includes flexible one 2 inch rubber coupling and two adjustable bands.

Approved for all Lennox 90% furnaces.

#### **Termination Kits**

Facilitates installation of combustion air intake pipe and flue exhaust pipe.

Refer to venting table in this bulletin to determine pipe size needed and proper termination kit required.

See Optional Accessories table and dimension drawings.

#### **Termination Kit - Concentric - Direct Vent Applications**

2 or 3 inch kit contains concentric termination assembly, reducer bushing and 45° elbow.

2 inch kit for -045-070 models contains an outdoor exhaust accelerator.

Kit requires single hole penetration of roof or wall for installation.

Roof Termination Flashing Kit is available for use with 2 inch Kits.

CSA certified.

#### **Termination Kit - Flush-Mount**

Kit contains flush-mount termination, accelerator, mounting template and hardware.

Kit may be used with 2, 2-1/2 or 3 in. pipe.

#### **Termination Kits - Wall Assembly**

#### **Close Couple (US Only) - Direct Vent Applications**

2 or 3 inch kit consists of close-couple, side-by-side PVC piping with galvanized steel wall cover plate for sealing and isolating piping penetration of the wall.

Piping spacing and length is sized for proper wall installations.

CSA certified.

#### **Close Couple WTK (Canada Only) - Direct Vent Applications**

2 or 3 inch kit contains one insulated faceplate, one insulated exhaust pipe, elbow and fittings.

#### **Wall Ring - Direct Vent or Non-Direct Vent Applications**

2 inch kit contains 2 stainless steel outside seal caps, 2 galvanized steel inside seal caps, 4 seal rings for the caps and 18 inch insulation sleeve for sealing and isolating intake and exhaust piping penetration of wall.

Maintain a maximum of 6 inches between the inlet and outlet openings in the installation of the pipes.

#### **Roof Termination Flashing Kit**

2 or 3 inch kit contains two neoprene rubber roof flashings for vertical venting through a roof.

Vent pipe and insulation not furnished.

Also available for use with 2 inch (use 3 inch flashing) Concentric Vent Termination Kits used in vertical venting rooftop applications.

## **8 CONTROLS**

### **Integrated Furnace Control**

Contains all necessary controls and relays to operate furnace.

Combustion air inducer is controlled by the integrated furnace control. Prior to ignition, a pre-purge cycle for 15 seconds is initiated. After the main burners are turned off, a post-purge cycle for 5 seconds is run.

Control continuously monitors line voltage and maintains the igniter power at a constant level to provide consistent lighting and maximum igniter life.

Flame sensor assures safe and reliable operation.

Should loss of flame occur the integrated furnace control will initiate 4 re-attempts at ignition before locking out unit operation for 60 minutes.

Watchguard type circuit automatically resets ignition controls after one hour of continuous thermostat demand after unit lockout, eliminating nuisance calls for service.



## FEATURES

### **CONTROLS (continued)**

Fan control consists of adjustable blower timed-off delay (60, 90, 120, 180 seconds - factory setting 120 seconds) and fixed blower timed-on delay (30 seconds).

For air-conditioning applications, blower is automatically energized on thermostat demand for cooling.

Integrated furnace control has one red LED to indicate status and indicate diagnostic codes. Push button recall of the last 5 diagnostic codes aids in troubleshooting.

Integrated furnace control has built-in twinning capability ("TWIN" terminal on control) to operate two furnaces simultaneously without any additional controls. A field supplied isolation relay is required to operate the twinned (no thermostat connection) furnace.

Two accessory terminals furnished for additional power supply requirements for 120 volt (less than 1 amp) power humidifiers and powered air cleaners.

#### **24 Volt Transformer**

Furnished and factory installed in control box. 40VA transformer has fuse wired in series.

#### **Field Wiring Make-Up Box**

Furnished for line voltage wiring.

Factory installed internally on left side of furnace.

Box may be installed internally or externally on either side of furnace.

### **Optional Accessories**

#### **iComfort® M30 Smart Wi-Fi Thermostat**

Wi-Fi-enabled, electronic 7-day, universal, multi-stage, programmable, touchscreen thermostat.

4 Heat/2 Cool.

Auto-changeover.

Dual-fuel control with optional outdoor sensor.

Controls dehumidification during cooling mode and humidification during heating mode.

Offers enhanced capabilities including humidification / dehumidification / dewpoint measurement and control, *Humiditrol*® control, and equipment maintenance reminders.

Easy to read 4.3 in. color touchscreen (measured diagonally).

LCD display with backlight shows the current and set temperature, time, inside relative humidity, system status (operating mode and schedules) and outside temperature (optional outdoor sensor required).

Smooth Setback Recovery starts system early to achieve setpoint at start of program period.

Compressor short-cycle protection (5 minutes).

Up to four separate schedules are available plus Schedule IQ™.



One-Touch Away Mode - A quick and easy way to set the cooling and heating setpoints while away.

Smart Away™ - Uses geo-fencing technology to determine when the homeowner is within a predetermined distance from the home to operate the system when leaving, away and arriving.

Amazon® Alexa-enabled, smart-home-compatible. It works with Amazon Echo, Echo Dot and Tap devices.

Wi-Fi remote monitoring and adjustment through a home wireless network for desktop PCs, laptops and apps for smartphones or tablets.

See the iComfort® M30 Smart Wi-Fi Thermostat Product Specifications bulletin in the Controls section for more information.

#### **Remote Outdoor Temperature Sensor**

Used with the iComfort® M30 Smart Thermostat.

When installed outdoors, sensor allows thermostat to display outdoor temperature. Sensor is auto-detected when connected to thermostat.

*NOTE - Sensor is required for the Enhanced Dehumidification Accessory (EDA).*



#### **Thermostat**

Thermostat (programmable/non-programmable) is not furnished with unit.

See Thermostat bulletins in Controls Section and Lennox Price Book for selection.

#### **Night Service Kit**

Contains most commonly used service parts:

- Furnace control
- Igniter
- Flame sensor
- Gas valve
- Transformer
- Service Manual

#### **BLOWER**

- 9 Multi-speed direct drive blower.

Statically and dynamically balanced.

Resiliently mounted.

Blower assembly easily removed for servicing.

Blower speeds are easily changed on the integrated furnace control. See blower performance tables.

## FEATURES

### CABINET

Low-profile, narrow width cabinet allows easy installation in upflow or horizontal applications.

Heavy-gauge, cold rolled steel construction.

Pre-painted cabinet finish.

Flanges provided on supply air opening for ease of plenum connection or alignment with indoor coil.

- 10 Insulated cabinet with foil faced insulation on sides and back of heating compartment.

Sealed blower compartment.

Complete service access.

Safety interlock switch automatically shuts off power to unit when blower compartment access door is removed.

- 11 Gas piping and electrical inlets are provided in both sides of cabinet.

#### Return Air Entry

For bottom/end return-air entry for upflow/horizontal applications, remove furnished bottom seal panel from cabinet.

For side return-air entry (upflow applications only), corners are marked on either side of cabinet for return air cut-outs.

See dimension drawings.

#### NOTE - 60C and 60D size units that require air volumes over 1800 cfm must have one of the following:

1. Single side return air and Optional Return Air Base with transition that must accommodate required 20 x 25 x 1 inch air filter to maintain proper velocity.
2. Bottom return air.
3. Return air from both sides.
4. Bottom and one side return air.

See Blower Performance Tables for additional information.

#### Coil Match-Up

All furnaces exactly match Lennox cased upflow indoor coils and horizontal indoor coils with same letter designation (A, B, C, D) in model number. No adaptor required. Engaging holes furnished on cabinet for alignment.

Lennox uncased coils match furnaces without any overhang but require an optional adaptor base or field fabricated transition to match furnace opening. See coil bulletin for additional information.

#### Low Leakage Cabinet

All models have less than 2% air leakage and meet ANSI/ASHRAE Standard 193-2010 *“Method of Test for Determining the Air Tightness of HVAC Equipment”*

### Optional Accessories

#### Condensate Drain Heat Cable Kits

Self-limiting wattage heat cable prevents condensate drain from freezing in unconditioned areas.

Available in 6 or 24 ft. lengths.

#### Horizontal Suspension Kit

Provides suspension of unit and indoor coil in horizontal applications.

Allows complete service access.

Consists of corner mounted hanging brackets with vibration isolators, return air end support rail and hardware for assembly.

Metal hanging straps must be field provided.

#### Crawl Space Vent Drain Kit

Allows venting through a crawl space for upflow and horizontal applications.

Includes 2 or 3 in. sanitary tee, 2 in. PVC assembly, PVC boot and clamp.

Kit for Canada is certified to ULC S636.

#### Return Air Base

On furnaces with side return air and condensate trap on the same side of the cabinet, a field fabricated transition or Return Air Base is required when using an IAQ product higher than 14-3/16 in. installed next to the unit and serviced from the front.

IAQ products higher than 20 in. require a field fabricated transition.

Must be used for 60C and 60D models with air volumes over 1800 cfm in upflow applications when only one side return is required.

Cabinet is shipped flat for easy field assembly and is pre-painted steel to match the furnace.

See Dimension Drawing.

#### High Performance Economizer (Commercial Applications Only)

Designed for applications requiring outdoor air to be utilized in a commercial HVAC system. Allows the entry of fresh outdoor air for free cooling, reducing the requirement for mechanical cooling.

Heavy gauge galvanized steel cabinet lined with thick fiberglass insulation.

Mixed air sensor, outdoor air sensor and 24VAC transformer furnished.

Approved for California Title 24 building standards.

ASHRAE 90.1-2010 compliant.

See separate Product Specifications bulletin for additional information and available control and sensor options.

## FEATURES

### **FILTER (not furnished)**

Filter and provisions for external mounting must be field provided.

### **Optional Accessories**

#### **Air Filter and Rack Kit for Horizontal Return Air (End) Applications**

Washable or vacuum cleanable polyurethane frame type filter and external end return air rack available for field installation.

Rack has filter door for easy filter servicing.

Flanges on rack allow easy duct connection.

See dimension drawing.

#### **Air Filter and Rack Kit for Upflow Side Return Air**

Applications - Not for use with Return Air Base

Washable or vacuum cleanable polyurethane frame type filter and external side return air rack available for field installation.

Available in single and ten pack kits.

Rack has filter door for easy filter servicing.

Flanges on rack allow easy duct connection.

Field installs on either side of unit cabinet. See dimension drawing.

## SPECIFICATIONS

Gas Heating Performance		Model No.	ML193UH045XP24B	ML193UH045XP36B	ML193UH070XP24B
		AHRI Ref. No.	4792130	4792131	4792132
		<sup>1</sup> AFUE	93%	93%	93%
		Input - Btuh	44,000	44,000	66,000
		Output - Btuh	41,000	42,000	62,000
		Temperature rise range - °F	35 - 65	25 - 55	50 - 80
		Gas Manifold Pressure (in. w.g.) Nat. Gas / LPG/Propane	3.5 / 10.0	3.5 / 10.0	3.5 / 10.0
		High static - in. w.g.	0.50	0.50	0.50
Connections in.	Intake / Exhaust Pipe (PVC)		2 / 2	2 / 2	2 / 2
	Gas pipe size IPS		1/2	1/2	1/2
	Condensate Drain Trap (PVC pipe) - i.d.		3/4	3/4	3/4
	with furnished 90° street elbow with field supplied (PVC coupling) - o.d.		3/4 slip x 3/4 Mipt 3/4 slip x 3/4 MPT	3/4 slip x 3/4 Mipt 3/4 slip x 3/4 MPT	3/4 slip x 3/4 Mipt 3/4 slip x 3/4 MPT
Indoor Blower	Wheel nom. dia. x width - in.		10 x 8	10 x 8	10 x 8
	Motor output - hp		1/5	1/3	1/5
	Tons of add-on cooling		1.5 - 2	2.5 - 3	1.5 - 2
	Air Volume Range - cfm		390 - 1140	700 - 1600	390 - 1140
Electrical Data	Voltage	120 volts - 60 hertz - 1 phase			
	Blower motor full load amps		3.1	6.1	3.1
	Maximum overcurrent protection		15	15	15
Shipping Data	lbs. - 1 package		120	122	125

NOTE - Filters and provisions for mounting are not furnished and must be field provided.

<sup>1</sup> Annual Fuel Utilization Efficiency based on DOE test procedures and according to FTC labeling regulations. Isolated combustion system rating for non-weatherized furnaces.

## SPECIFICATIONS

Gas Heating Performance		Model No.	ML193UH070XP36B	ML193UH090XP36C	ML193UH090XP48C
		AHRI Ref. No.	4792133	4792134	4792309
		<sup>1</sup> AFUE	93%	93%	93%
		Input - Btuh	66,000	88,000	88,000
		Output - Btuh	62,000	83,000	83,000
		Temperature rise range - °F	40 - 70	50 - 80	40 - 70
		Gas Manifold Pressure (in. w.g.) Nat. Gas / LPG/Propane	3.5 / 10.0	3.5 / 10.0	3.5 / 10.0
		High static - in. w.g.	0.50	0.50	0.50
Connections in.	Intake / Exhaust Pipe (PVC)		2 / 2	2 / 2	2 / 2
	Gas pipe size IPS		1/2	1/2	1/2
	Condensate Drain Trap (PVC pipe) - i.d.		3/4	3/4	3/4
	with furnished 90° street elbow with field supplied (PVC coupling) - o.d.		3/4 slip x 3/4 Mipt 3/4 slip x 3/4 MPT	3/4 slip x 3/4 Mipt 3/4 slip x 3/4 MPT	3/4 slip x 3/4 Mipt 3/4 slip x 3/4 MPT
Indoor Blower	Wheel nom. dia. x width - in.		10 x 8	10 x 8	10 x 10
	Motor output - hp		1/3	1/3	1/2
	Tons of add-on cooling		2.5 - 3	2 - 3	3 - 4
	Air Volume Range - cfm		660 - 1615	695 - 1620	900 - 2025
Electrical Data	Voltage	120 volts - 60 hertz - 1 phase			
	Blower motor full load amps		6.1	6.1	8.2
	Maximum overcurrent protection		15	15	15
Shipping Data	lbs. - 1 package		127	143	146

NOTE - Filters and provisions for mounting are not furnished and must be field provided.

<sup>1</sup> Annual Fuel Utilization Efficiency based on DOE test procedures and according to FTC labeling regulations. Isolated combustion system rating for non-weatherized furnaces.



## SPECIFICATIONS

		Model No.	ML193UH110XP48C	ML193UH110XP60C	ML193UH135XP60D
<b>Gas Heating Performance</b>	AHRI Ref. No.		4792830	4792833	4792834
	<sup>1</sup> AFUE		93%	93%	93%
	Input - Btuh		110,000	110,000	132,000
	Output - Btuh		104,000	104,000	124,000
	Temperature rise range - °F		50 - 80	40 - 70	45 - 75
	Gas Manifold Pressure (in. w.g.) Nat. Gas / LPG/Propane		3.5 / 10.0	3.5 / 10.0	3.5 / 10.0
	High static - in. w.g.		0.50	0.50	0.50
<b>Connections in.</b>	Intake / Exhaust Pipe (PVC)		2 / 2	2 / 2	2 / 2
	Gas pipe size IPS		1/2	1/2	1/2
	Condensate Drain Trap (PVC pipe) - i.d.		3/4	3/4	3/4
	with furnished 90° street elbow		3/4 slip x 3/4 Mipt	3/4 slip x 3/4 Mipt	3/4 slip x 3/4 Mipt
	with field supplied (PVC coupling) - o.d.		3/4 slip x 3/4 MPT	3/4 slip x 3/4 MPT	3/4 slip x 3/4 MPT
<b>Indoor Blower</b>	Wheel nom. dia. x width - in.		10 x 10	11 ½ x 10	11 ½ x 10
	Motor output - hp		1/2	1	1
	Tons of add-on cooling		3 - 4	4 - 5	4 - 5
	Air Volume Range - cfm		850 - 2030	1210 - 2525	1340 - 2800
<b>Electrical Data</b>	Voltage		120 volts - 60 hertz - 1 phase		
	Blower motor full load amps		8.2	11.5	11.5
	Maximum overcurrent protection		15	15	15
<b>Shipping Data</b>	lbs. - 1 package		155	161	178

NOTE - Filters and provisions for mounting are not furnished and must be field provided.

<sup>1</sup> Annual Fuel Utilization Efficiency based on DOE test procedures and according to FTC labeling regulations. Isolated combustion system rating for non-weatherized furnaces.

## INSTALLATION CLEARANCES

Sides	<sup>1</sup> 0 inches (0 mm)
Rear	0 inches (0 mm)
Top/Plenum	1 inch (25 mm)
Front	0 inches (0 mm)
Front (service/alcove)	24 inches (610 mm)
Floor	<sup>2</sup> Combustible

NOTE - Air for combustion must conform to the methods outlined in the National Fuel Gas Code (NFPA 54/ANSI-Z223.1) or the National Standard of Canada CAN/CSA-B149.1 Natural Gas and Propane Installation Code".

NOTE - In the U.S. flue sizing must conform to the methods outlined in the current National Fuel Gas Code (NFPA 54/ANSI-Z223.1) or applicable provisions of local building codes. In Canada flue sizing must conform to the methods outlined in National Standard of Canada CAN/CSA-B149.1.

<sup>1</sup> Allow proper clearances to accommodate condensate trap and vent pipe installation.

<sup>2</sup> Do not install the furnace directly on carpeting, tile, or other combustible materials other than wood flooring.

## OPTIONAL ACCESSORIES - ORDER SEPARATELY

			"B" Width Models	"C" Width Models	"D" Width Models
<b>CABINET ACCESSORIES</b>					
Horizontal Suspension Kit - Horizontal only			51W10	51W10	51W10
Return Air Base - Upflow only			50W98	50W99	51W00
High Performance Economizer (Commercial Only)			10U53	10U53	10U53
<b>CONDENSATE DRAIN KITS</b>					
Condensate Drain Heat Cable	6 ft.		26K68	26K68	26K68
	24 ft.		26K69	26K69	26K69
Crawl Space Vent Drain Kit	US		51W18	51W18	51W18
	Canada		15Z70	15Z70	15Z70
<b>CONTROLS</b>					
iComfort® M30 Smart Wi-Fi Thermostat			15Z69	15Z69	15Z69
Remote Outdoor Air Temperature Sensor			X2658	X2658	X2658
Night Service Kit			68W80	68W80	68W80
<b>FILTER KITS</b>					
<sup>1</sup> Air Filter and Rack Kit	Horizontal (end) Side Return	Size of filter - in.	87L96 - 18 x 25 x 1	87L97 - 20 x 25 x 1	87L98 - 25 x 25 x 1
		Single	44J22	44J22	44J22
		Ten Pack	66K63	66K63	66K63
		Size of filter - in.	16 x 25 x 1	16 x 25 x 1	16 x 25 x 1
<b>TERMINATION KITS</b>					
See Installation Instructions for specific venting information.					
Termination Kits - Direct Vent Applications Only	Concentric	US - 2 in.	71M80	69M29	---
		3 in.	---	60L46	60L46
		Canada - 2 in.	44W92	44W92	---
		3 in.	---	44W93	44W93
	Flush-Mount	US - 2, 2-1/2 or 3 in.	51W11	51W11	51W11
		Canada - 2, 2-1/2 or 3 in.	51W12	51W12	51W12
	Wall - Close Couple	US - 2 in.	22G44	---	---
		3 in.	44J40	44J40	44J40
Wall - Close Couple WTK	Canada - 2 in.	30G28	---	---	
	3 in.	81J20	81J20	81J20	
Termination Kits - Direct or Non-Direct vent	Roof	2 in.	15F75	15F75	---
	Wall Ring Kit	2 in.	15F74	<sup>3</sup> 15F74	---
<sup>2</sup> Roof Termination Flashing Kit - Direct or Non-Direct Vent (2 flashings)		2 in.	44J41	44J41	44J41
<b>VENTING</b>					
Flue Coupling		2 in.	17H92	17H92	17H92

<sup>1</sup> Cleanable polyurethane frame type filter.

<sup>2</sup> Kits contain enough parts for two, non-direct vent installations.

<sup>3</sup> Non-direct vent only.

NOTE - Termination Kits (44W92, 44W93, 30G28, 51W12, 51W19, 81J20) and Crawl Space Vent Drain Kit (15Z70) are certified to ULC S636 standard for use in Canada only.

## GAS HEAT ACCESSORIES

Input	High Altitude Pressure Switch Kit		Natural Gas to LPG/Propane Kit	LPG/Propane to Natural Gas Kit	Natural Gas High Altitude Orifice Kit	LPG/Propane High Altitude Orifice Kit	<sup>1</sup> 36K Derate Kit (Natural Gas)	Muffler (US Only)
	4501 - 7500 ft.	7501 - 10,000 ft.	0 - 7500 ft.	0 - 7500 ft.	7501 - 10,000 ft.	7501 - 10,000 ft.	0 - 10,000 ft.	
045	11U65	11U66	11K49	73W81	73W37	11K44	10K55	15Y66 (2-inch)
070	11U65	11U66	11K49	73W81	73W37	11K44	---	15Y66 (2-inch)
090	11U65	11U66	11K49	73W81	73W37	11K44	---	15Y66 (2-inch)
110	11U65	11U66	11K49	73W81	73W37	11K44	---	<sup>2</sup> 15Y66 (2-inch) 16A56 (3-inch)
135	11U70	11U68	11K49	73W81	73W37	11K44	---	16A56 (3-inch)

<sup>1</sup> NOTE - 36K Derate Kit information - Reduced Input is 36,000 Btu/h, output is 34,200 Btu/h.

<sup>2</sup> Two-inch diameter muffler (15Y66) is optional for 110 input model with a maximum vent pipe length of up to 29 ft. Three-inch diameter muffler (16A56) is optional for 110 input model with a minimum vent pipe length of 30 ft.

## HIGH ALTITUDE DERATE

NOTE - Units may be installed at altitudes up to 10,000 ft.

At altitudes above 4501 ft. the unit must be derated to match the manifold pressure information shown below.

Units installed at altitudes of 4501 to 10,000 ft. require a pressure switch change.

Units installed at altitudes of 7501 to 10,000 ft. require an orifice change.

See the Gas Heat Accessories table for ordering information.

NOTE - This is the only permissible derate for these units.

NOTE - In Canada, certification for installations at elevations over 4500 feet is the jurisdiction of local authorities.

Input	Gas	Manifold Pressure in. w.g.					Supply Line Pressure in. w.g. 0 - 10,000 ft.	
		0 - 4500 ft.	4501 - 5500 ft.	5501 - 6500 ft.	6501 - 7500 ft.	7501 - 10,000 ft.		
All Sizes	Natural	3.5	3.3	3.2	3.1	3.5	4.5	13.0
	LPG/Propane	10.0	9.4	9.1	8.9	10.0	11.0	13.0

## OUTDOOR TERMINATION KIT USAGE

Input Size	Vent Pipe Diameter (in.)	Standard Terminations				Concentric Terminations			
		Flush Mount Kit	Wall Kit		Wall Ring Kit	Field Fabricated Exhaust Accelerator Size Required	Concentric Kit		
			2 inch	3 inch	2 inch		1-1/2 inch	2 inch	3 inch
		51W11 (US) 4 51W12 (CA)	22G44 (US) 4 30G28 (CA)	44J40 (US) 4 81J20 (CA)	15F74		71M80 (US) 4 44W92 (CA)	69M29 (US) 4 44W92 (CA)	60L46 (US) 4 44W93 (CA)
045	2	<sup>3</sup> YES	YES	<sup>1</sup> YES	YES	1-1/2 in.	<sup>2</sup> YES	---	---
	2-1/2	<sup>3</sup> YES	YES	<sup>1</sup> YES	YES	1-1/2 in.	<sup>2</sup> YES	---	---
	3	<sup>3</sup> YES	YES	<sup>1</sup> YES	YES	1-1/2 in.	<sup>2</sup> YES	---	---
070	2	<sup>3</sup> YES	YES	<sup>1</sup> YES	YES	1-1/2 in.	<sup>2</sup> YES	---	---
	2-1/2	<sup>3</sup> YES	YES	<sup>1</sup> YES	YES	1-1/2 in.	<sup>2</sup> YES	---	---
	3	<sup>3</sup> YES	YES	<sup>1</sup> YES	YES	1-1/2 in.	<sup>2</sup> YES	---	---
090	2	<sup>3</sup> YES	---	YES	<sup>1</sup> YES	2 in.	---	YES	YES
	2-1/2	<sup>3</sup> YES	---	YES	<sup>1</sup> YES	2 in.	---	YES	YES
	3	<sup>3</sup> YES	---	YES	<sup>1</sup> YES	2 in.	---	YES	YES
110	2	YES	---	YES	YES	2 in.	---	YES	YES
	2-1/2	YES	---	YES	---	2 in.	---	YES	YES
	3	YES	---	YES	---	2 in.	---	YES	YES
135	3	YES	---	YES	---	2 in.	---	---	YES

NOTE - Standard Terminations do not include any vent pipe or elbows external to the structure.

Any vent pipe or elbows external to the structure must be included in total vent length calculations. See Vent Length Tables.

<sup>1</sup> Requires field provided 1-1/2 in. outdoor exhaust accelerator.

<sup>2</sup> Concentric Kits **71M80** and **44W92** include 1-1/2 in. outdoor exhaust accelerator, required when used with 045 and 070 input models. Accelerator is not used with 090, 110, 135 input models.

<sup>3</sup> Flush Mount Kit **51W11** and **51W12** includes 1-1/2 in. outdoor exhaust accelerator, required when used with 045, 070 and 090 input models. Accelerator is not used with 110 or 135 input models.

<sup>4</sup> Termination Kits **30G28**, **44W92**, **44W93**, **51W12** and **81J20** are certified to ULC S636 standard for use in Canada only.

## VENT LENGTHS

### STANDARD TERMINATION AT ELEVATION 0 - 10,000 ft.

Pipe Size	2 in.					2-1/2 in.					3 in.					
	Input	045	070	090	110	135	045	070	090	110	135	045	070	090	110	135
No. of 90 ELL	1	81	66	44	24	N/A	115	100	68	43	N/A	137	137	118	118	114
	2	76	61	39	19	N/A	110	95	63	38	N/A	132	132	113	113	109
	3	71	56	34	14	N/A	105	90	58	33	N/A	127	127	108	108	104
	4	66	51	29	N/A	N/A	100	85	53	28	N/A	122	122	103	103	99
	5	61	46	24	N/A	N/A	95	80	48	23	N/A	117	117	98	98	94
	6	56	41	19	N/A	N/A	90	75	43	18	N/A	112	112	93	93	89
	7	51	36	14	N/A	N/A	85	70	38	13	N/A	107	107	88	88	84
	8	46	31	N/A	N/A	N/A	80	65	33	N/A	N/A	102	102	83	83	79
	9	41	26	N/A	N/A	N/A	75	60	28	N/A	N/A	97	97	78	78	74
	10	36	21	N/A	N/A	N/A	70	55	23	N/A	N/A	92	92	73	73	69

### CONCENTRIC TERMINATION ELEVATION 0 - 10,000 ft.

Pipe Size	2 in.					2-1/2 in.					3 in.					
	Input	045	070	090	110	135	045	070	090	110	135	045	070	090	110	135
No. of 90 ELL	1	73	58	42	22	N/A	105	90	64	39	N/A	121	121	114	114	105
	2	68	53	37	17	N/A	100	85	59	34	N/A	116	116	109	109	100
	3	63	48	32	12	N/A	95	80	54	29	N/A	111	111	104	104	95
	4	58	43	27	N/A	N/A	90	75	49	24	N/A	106	106	99	99	90
	5	53	38	22	N/A	N/A	85	70	44	19	N/A	101	101	94	94	85
	6	48	33	17	N/A	N/A	80	65	39	14	N/A	96	96	89	89	80
	7	43	28	12	N/A	N/A	75	60	34	N/A	N/A	91	91	84	84	75
	8	38	23	N/A	N/A	N/A	70	55	29	N/A	N/A	86	86	79	79	70
	9	33	18	N/A	N/A	N/A	65	50	24	N/A	N/A	81	81	74	74	65
	10	28	13	N/A	N/A	N/A	60	45	19	N/A	N/A	76	76	69	69	60

## VENT LENGTHS - UNINSULATED EXHAUST PIPE IN UNCONDITIONED SPACE

1 Winter Design Temperatures	Vent Pipe Diameter	Unit Input Size											
		045		070		090		110		135			
		Maximum Un-Insulated Exhaust Vent Length (ft.)											
		PVC	PolyPro InnoFlue	PVC	PolyPro InnoFlue	PVC	PolyPro InnoFlue	PVC	PolyPro InnoFlue	PVC	PolyPro InnoFlue	PVC	PolyPro InnoFlue
32 to 21°F	2 in.	18	16	31	28	50	48	30	30	N/A	N/A		
	2-1/2 in.	13	N/A	24	N/A	42	N/A	56	N/A	N/A	N/A		
	3 in.	9	9	18	18	35	35	47	47	52	52		
20 to 1°F	2 in.	9	8	18	16	32	29	30	30	N/A	N/A		
	2-1/2 in.	5	N/A	13	N/A	24	N/A	34	N/A	N/A	N/A		
	3 in.	N/A	N/A	8	8	19	19	26	26	30	30		
0 to -20°F	2 in.	5	N/A	12	10	22	19	30	27	N/A	N/A		
	2-1/2 in.	N/A	N/A	7	N/A	15	N/A	22	N/A	N/A	N/A		
	3 in.	N/A	N/A	N/A	N/A	10	10	16	16	18	18		

NOTE - Concentric terminations are equivalent to 5 ft. of straight pipe and should be included when measuring total pipe length.

<sup>1</sup> Refer to 99% Minimum Design Temperature table provided in the current edition of the ASHRAE Handbook-Fundamentals.

PolyPro® poly-propylene vent pipe is a registered trademark of DuraVent®.

InnoFlue® is a registered trademark of Centrotherm Eco Systems.

## DIMENSIONS - UPFLOW POSITION

<sup>1</sup> NOTE - 60C and 60D size units that require air volumes over 1800 cfm must have one of the following:

1. Single side return air and Optional Return Air Base with transition that must accommodate required 20 x 25 x 1 inch (508 x 635 x 25 mm) air filter to maintain proper velocity.
  2. Bottom return air.
  3. Return air from both sides.
  4. Bottom and one side return air.
- See Blower Performance Tables for additional information.

<sup>2</sup> Optional Side Return Air Filter Kit is not for use with the Optional Return Air Base.

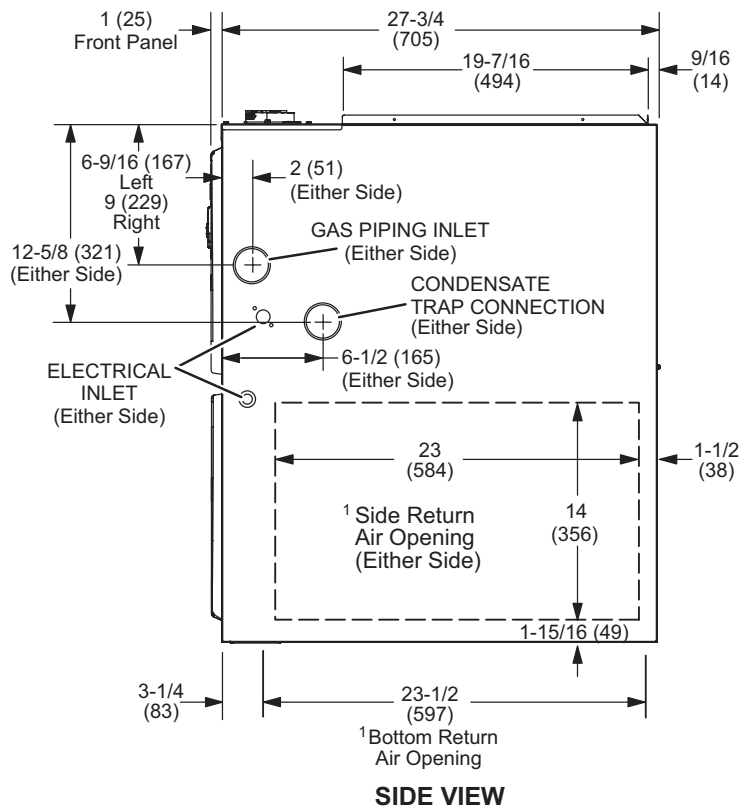
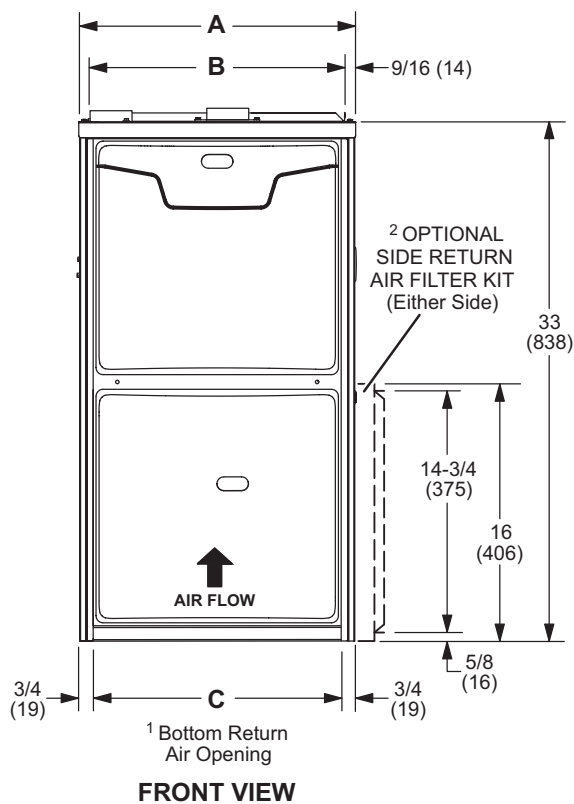
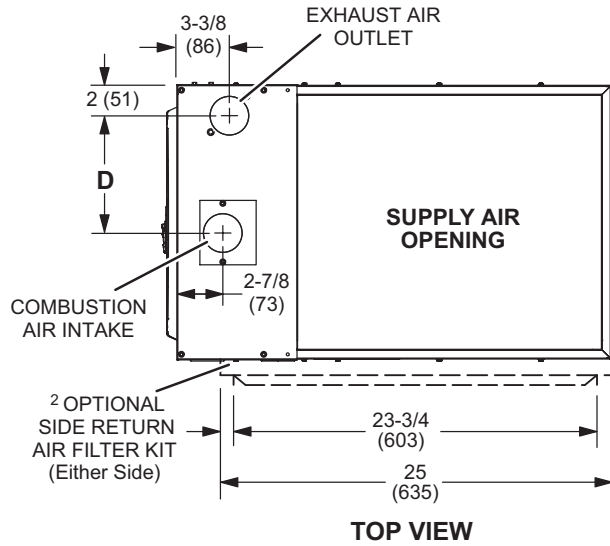
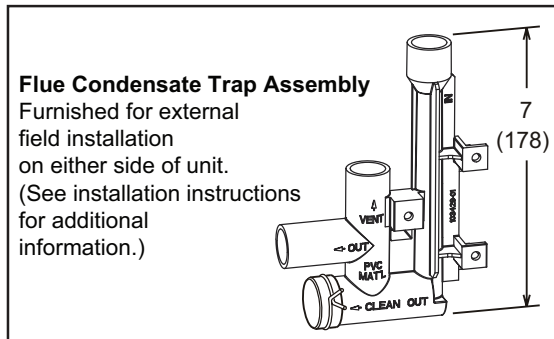

Model No.	A		B		C		D	
	in.	mm	in.	mm	in.	mm	in.	mm
ML193UH045XP24B ML193UH045XP36B ML193UH070XP24B ML193UH070XP36B	17-1/2	446	16-3/8	416	16	406	7-5/8	194
ML193UH090XP36C ML193UH090XP48C ML193UH110XP48C ML193UH110XP60C	21	533	19-7/8	505	19-1/2	495	9-3/8	238
ML193UH135XP60D	24-1/2	622	23-3/8	594	23	584	11-1/8	283



# DIMENSIONS - HORIZONTAL POSITION

## LEFT-HAND AIR DISCHARGE

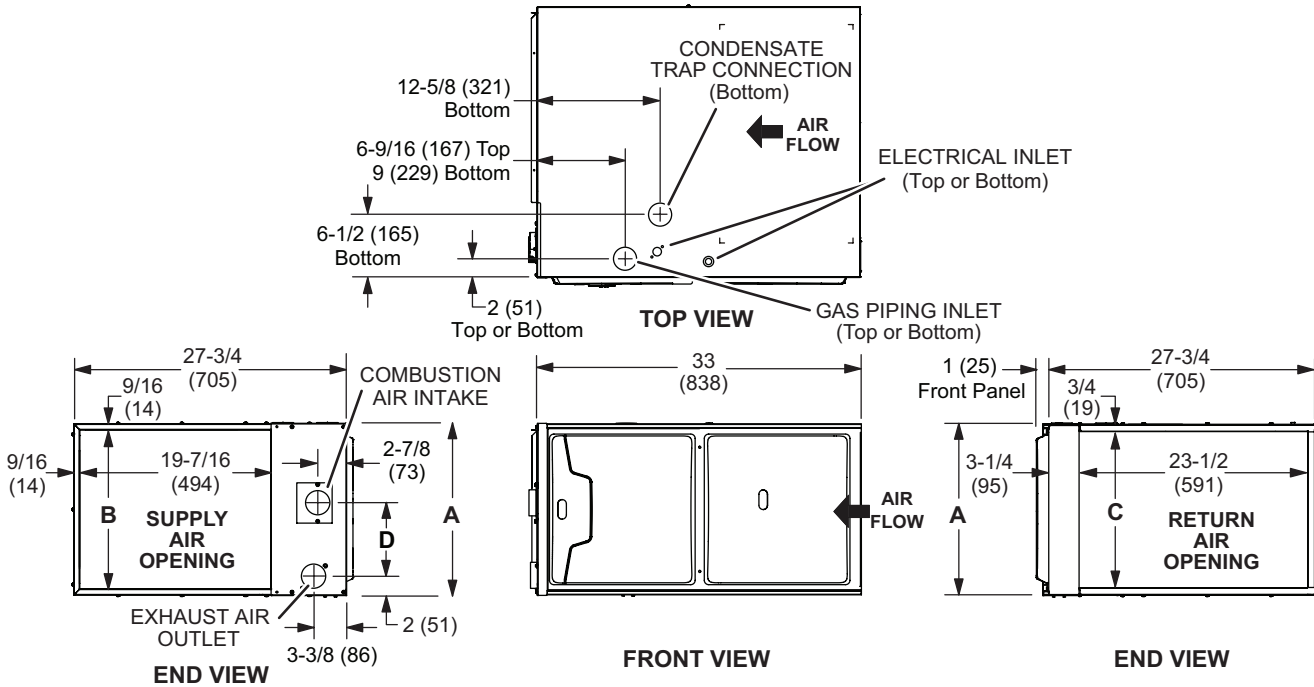

## RIGHT-HAND AIR DISCHARGE

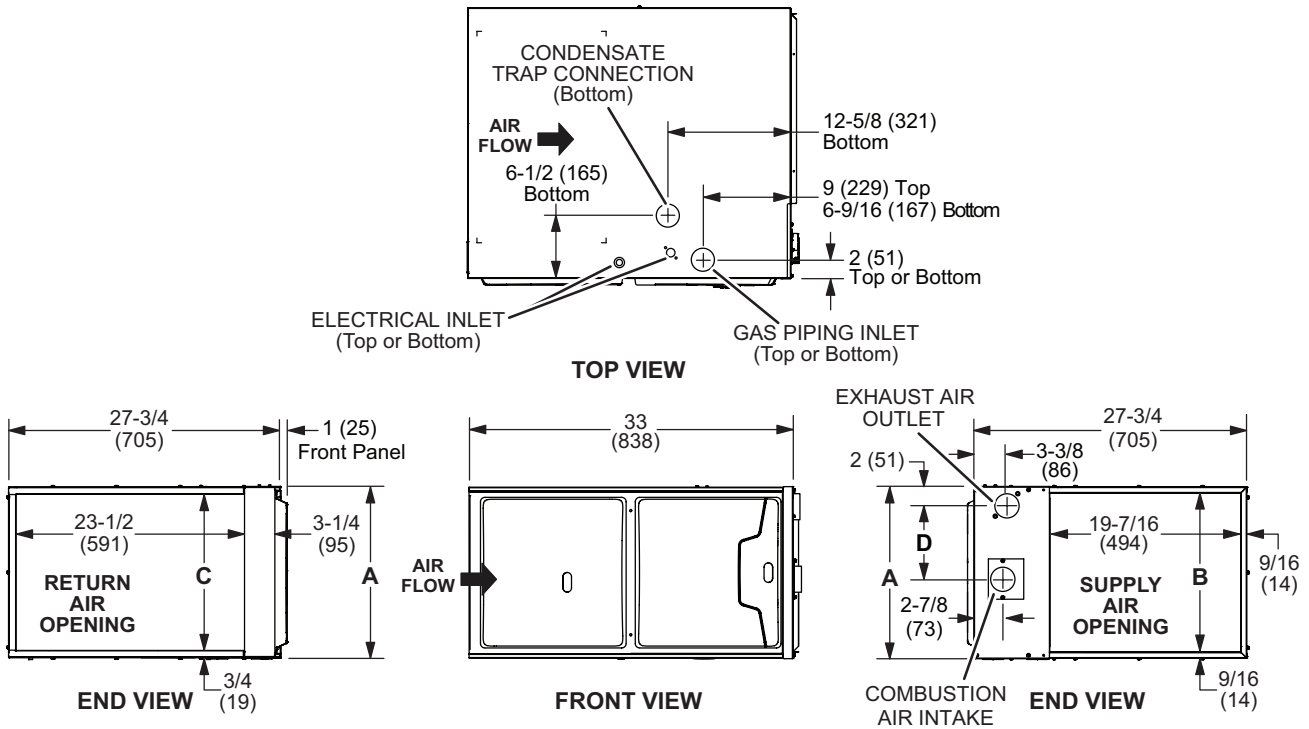

Model No.	A		B		C		D	
	in.	mm	in.	mm	in.	mm	in.	mm
ML193UH045XP24B	17-1/2	446	16-3/8	416	16	406	7-5/8	194
ML193UH045XP36B								
ML193UH070XP24B								
ML193UH070XP36B								
ML193UH090XP36C	21	533	19-7/8	505	19-1/2	495	9-3/8	238
ML193UH090XP48C								
ML193UH110XP48C								
ML193UH110XP60C								
ML193UH135XP60D	24-1/2	622	23-3/8	594	23	584	11-1/8	283

## OPTIONAL ACCESSORY DIMENSIONS

### HORIZONTAL (END) FILTER KIT

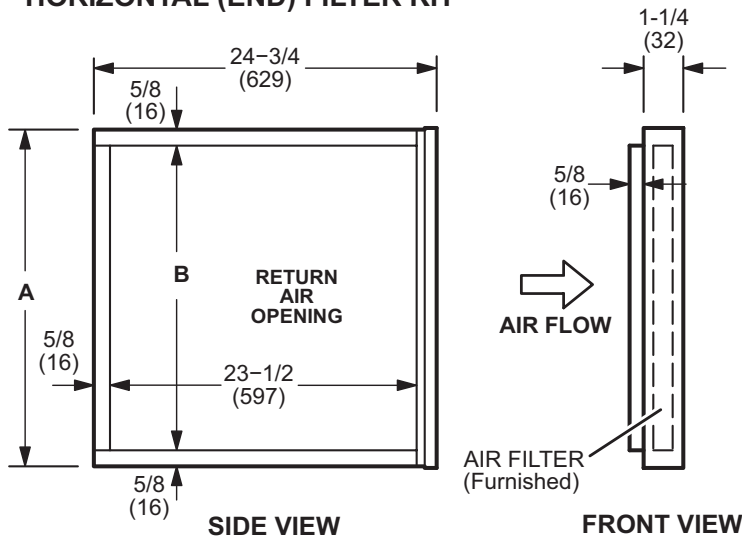

Furnace Cabinet Width	Catalog Number	A		B	
		in.	mm	in.	mm
B	87L96	18	457	16-3/4	425
C	87L97	21	533	18-3/4	476
D	87L98	25	635	23-3/4	603

### Optional Return Air Base (Upflow Applications Only - For use with B, C and D cabinets)

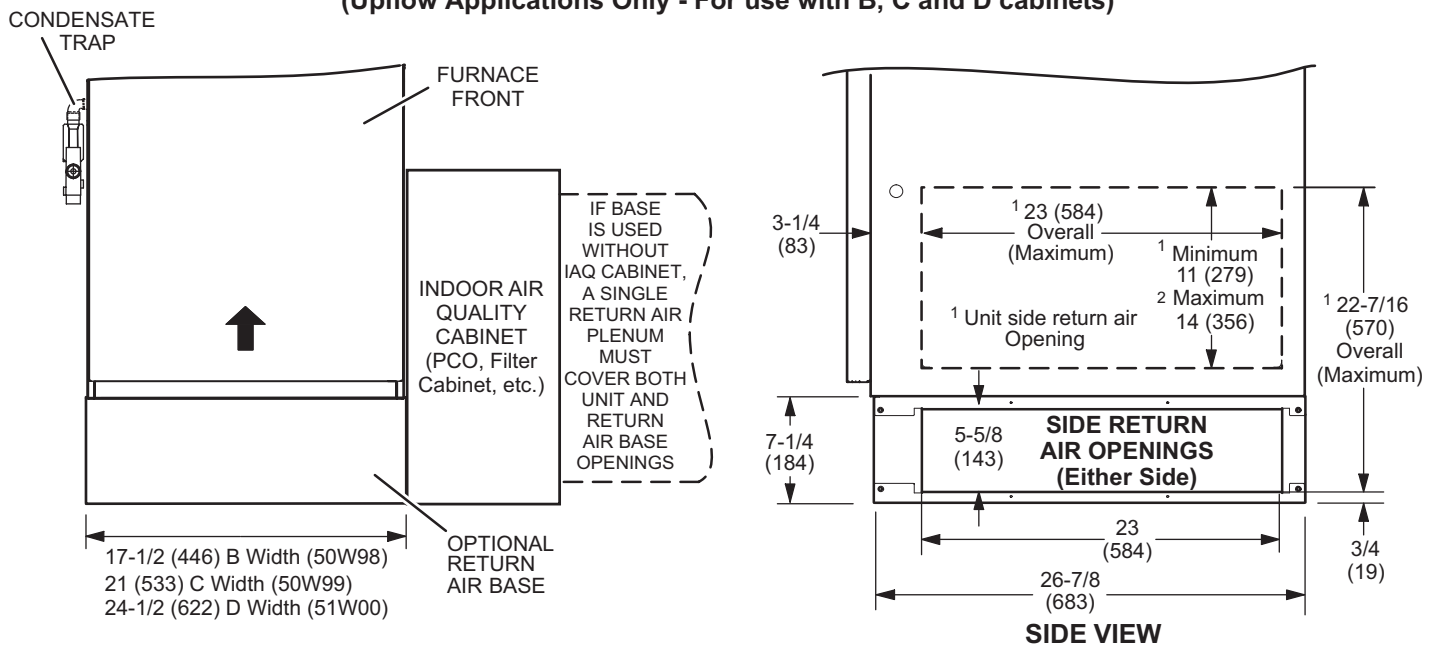

**NOTE-** Optional Side Return Air Filter Kits are not for use with Optional Return Air Base.

<sup>1</sup> Both the unit return air opening and the base return air opening must be covered by a single plenum or IAQ cabinet. Minimum unit side return air opening dimensions for units requiring 1800 cfm or more of air (W x H): 23 x 11 in. (584 x 279 mm). The opening can be cut as needed to accommodate plenum or IAQ cabinet while maintaining dimensions shown. Side return air openings must be cut in the field. There are cutting guides stenciled on the cabinet for the side return air opening. The size of the opening must not extend beyond the markings on the furnace cabinet.

<sup>2</sup> To minimize pressure drop, the largest opening height possible, up to 14 in. (356 mm), is preferred.

## DIMENSIONS - FURNACE/COIL COMBINED DIMENSIONS

### UPFLOW POSITION

Model No			C35/C37/CX35/CX38 Cased				C35 Uncased			
			A		B		A		B	
C35/CX35	C37	CX38	in.	mm	in.	mm	in.	mm	in.	mm
C35/CX35-18/24A C35/CX35-18/24B	---	---	16-1/2	419	49-1/2	1257	14-1/8	359	47-1/8	1197
C35/CX35-24A C35/CX35-24B	C37-25A C37-25B	CX38-25A CX38-25B	18-1/2	470	51-1/2	1308	16-3/8	416	49-3/8	1254
---	---	CX38-30A	20-1/2	521	53-1/2	1359	---	---	---	---
C35/CX35-30A C35/CX35-30B	C37-31A C37-31B	CX38-31A CX38-31B	22-1/2	572	55-1/2	1410	20-3/4	527	53-3/4	1365
C35/CX35-30/36A C35/CX35-30/36B C35/CX35-30/36C	C37-36A C37-36B C37-36C	CX38-36A CX38-36B CX38-36C	24-1/2	622	57-1/2	1461	22-1/4	565	55-1/4	1403
C35/CX35-36A C35/CX35-36B	C37-38A C37-38B	CX38-38A CX38-38B	24-1/2	622	57-1/2	1461	22-3/8	568	55-3/8	1407
---	C37-42B	CX38-42B	24-1/2	622	57-1/2	1461	---	---	---	---
C35/CX35-48B C35/CX35-48C	C37-43B C37-43C	CX38-43B CX38-43C	27-1/2	699	60-1/2	1537	26-1/4	667	59-1/4	1505
---	C37-48B C37-48C	CX38-44/48B CX38-44/48C	24-1/2	622	57-1/2	1461	---	---	---	---
C35/CX35-49C	C37-49C	CX38-49C	29-1/2	749	62-1/2	1588	28-1/2	724	61-1/2	1562
C35/CX35-50/60C	C37-50/60C	CX38-50/60C	27-1/2	699	60-1/2	1537	25-7/8	657	58-7/8	1495
---	C37-60D	CX38-60D	25-1/2	648	58-1/2	1486	---	---	---	---
CX35-60C	C37-62C	CX38-62C	31-1/2	800	64-1/2	1638	30-5/8	778	63-5/8	1616
CX35-60D	C37-62D	CX38-62D	29-1/2	749	62-1/2	1588	28	711	61	1549

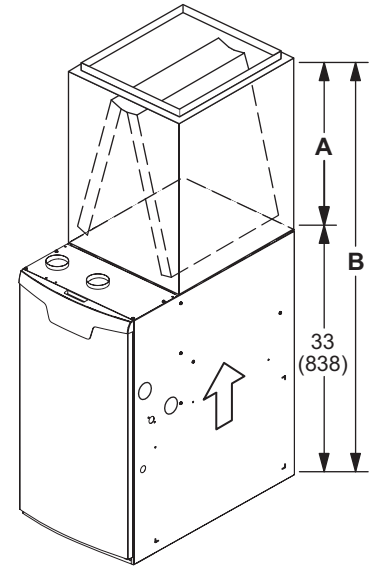

### HORIZONTAL POSITION

Model Number	A		B	
	in.	mm	in.	mm
<b>CH33</b>				
CH33-18A-2F	21-1/2	546	54-1/2	1384
CH33-24/30A-2F, CH33-42B-2F, CH33-36A-2F, CH33-48C-2F, CH33-36B-2F, CH33-60D-2F CH33-36C-2F,	26-1/2	673	59-1/2	1511
CH33-44/48B-2F, CH33-62D-2F CH33-50/60C-2F,	31-1/2	800	64-1/2	1638
<b>CH35</b>				
CH35-18A-2F, CH35-36A-2F, CH35-24A-2F, CH35-36B-2F, CH35-24B-2F, CH35-36C-2F, CH35-30B-2F, CH35-42C-2F, CH35-48C-2F	26-1/2	673	59-1/2	1511
CH35-30A-2F, CH35-51C-2F, CH35-42B-2F, CH35-60D-2F CH35-48B-2F,	31-1/2	880	64-1/2	1638

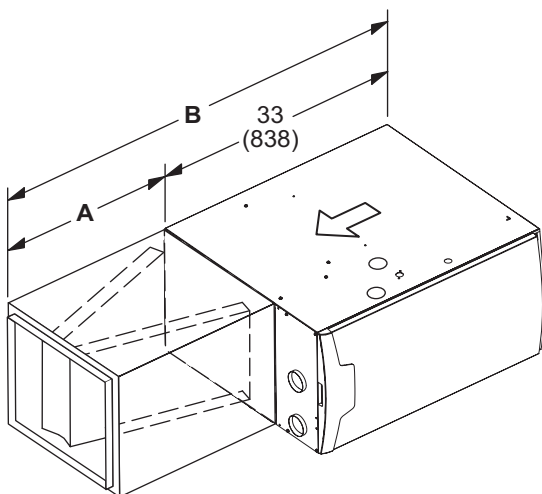

# OPTIONAL ACCESSORY DIMENSIONS

## FLUSH-MOUNT VENT TERMINATION KIT 51W11 (US) or 51W12 (CANADA)

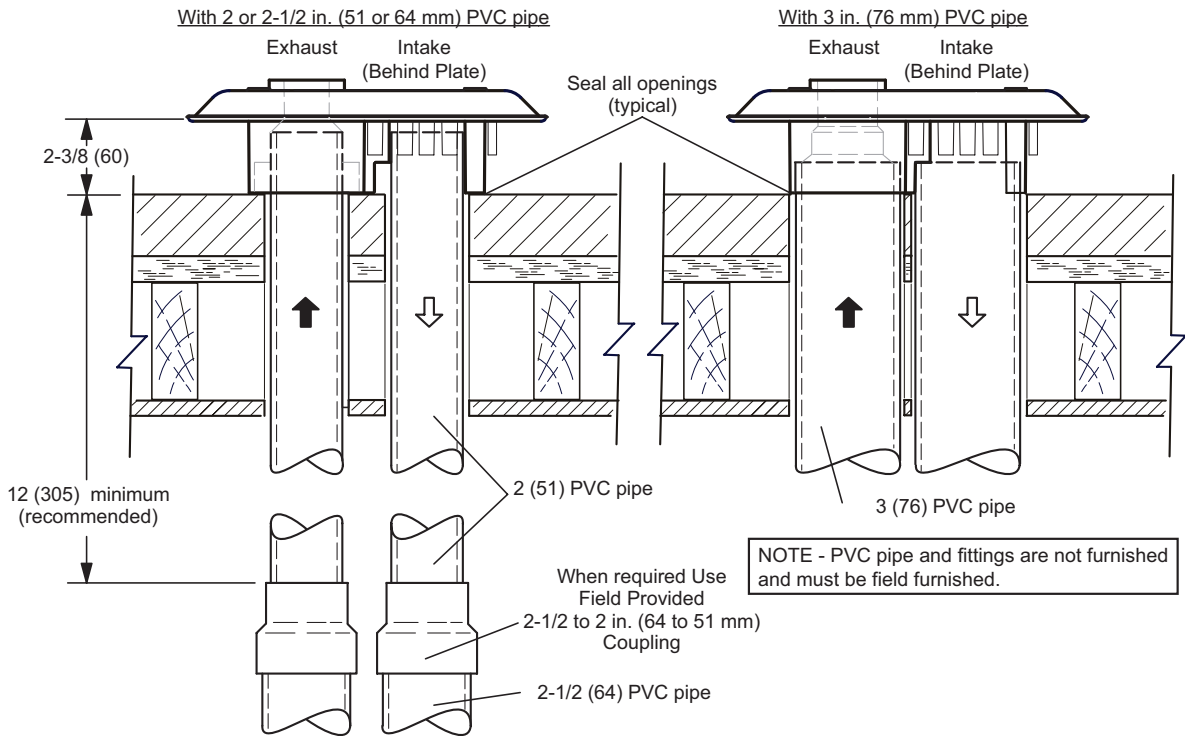
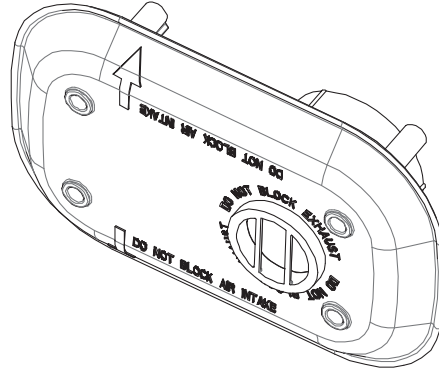

### MUFFLERS

15Y66 - 2-inch  
16A56 - 3-inch

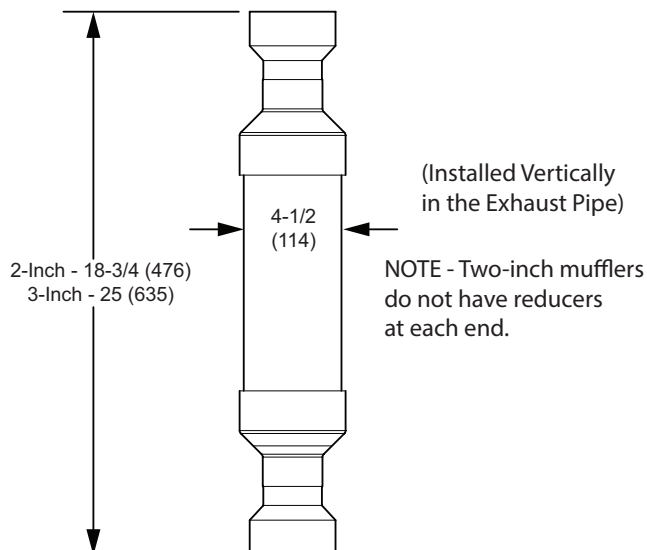

# OPTIONAL ACCESSORY DIMENSIONS

## CONCENTRIC WALL TERMINATION APPLICATIONS

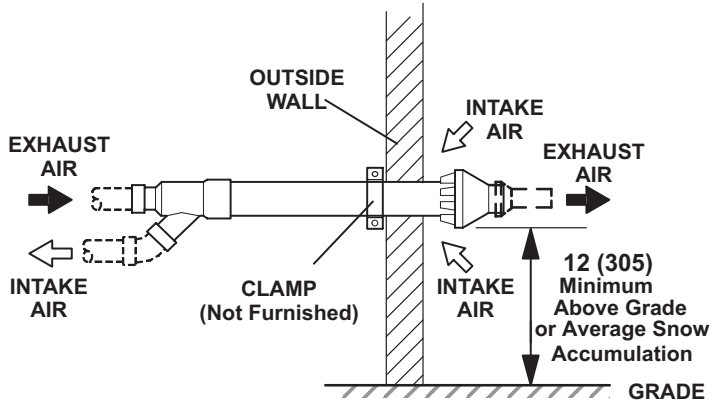

## CONCENTRIC ROOF TERMINATION APPLICATIONS

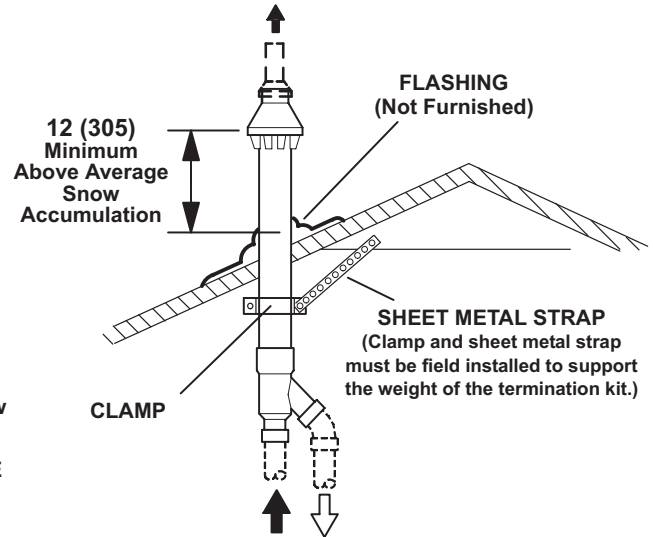

71M80 / 69M29 / 44W92 – 2 inch kits

60L46 / 44W93 – 3 inch kits

See Installation Instructions for additional information.

Note - Field provided reducer may be required to adapt larger vent pipe size to termination.

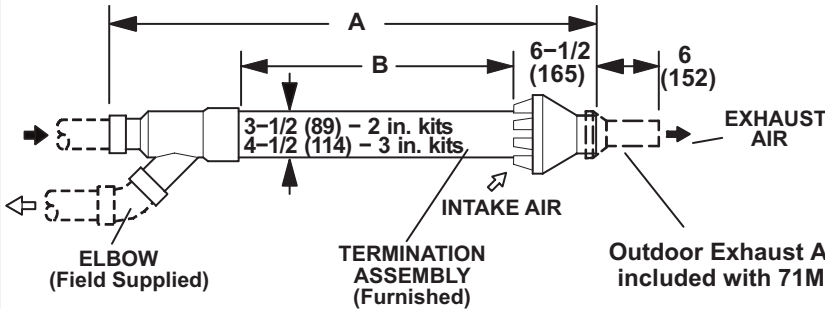

Cat. No.	A		B	
	in.	mm	in.	mm
71M80 69M29	33-3/8	848	16-3/4	425
44W92 (Canada)	29	737	15-1/2	394
60L46	38-7/8	987	21-3/16	538
44W93 (Canada)	36-1/8	918	19-1/2	495

NOTE - Typical illustration for dimensions only. Design may vary depending on kit ordered.

## WALL ASSEMBLY TERMINATION KIT - RING KIT 15F74 - 2 inch (51 mm)

See Installation Instructions for additional information.

Note - Field provided reducer may be required to adapt larger vent pipe size to termination.

### DIRECT VENT APPLICATION

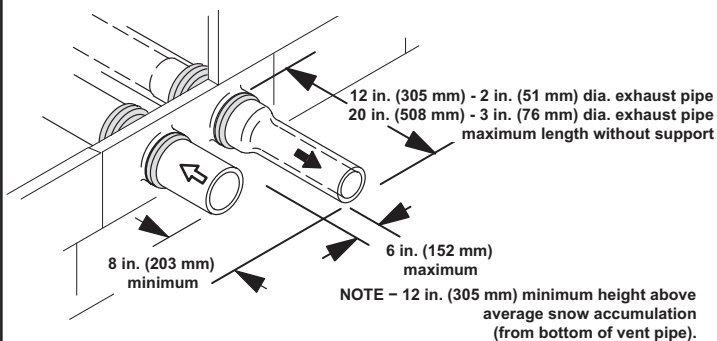

### NON-DIRECT VENT APPLICATION

NOTE - EXHAUST PIPE SHOWN  
Kit Contains Enough Parts For Two Installations

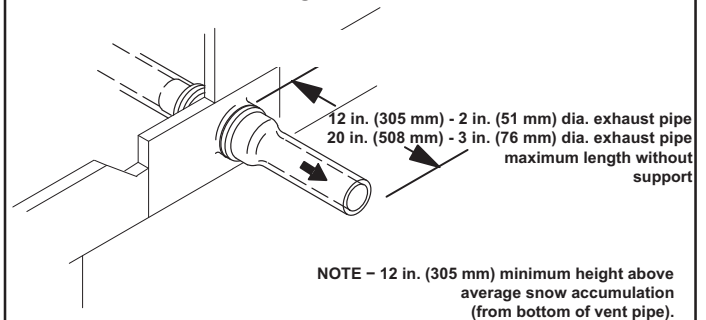



## OPTIONAL ACCESSORY DIMENSIONS

### WALL TERMINATION KITS (CLOSE-COUPLE) EXTENDED VENT FOR GRADE CLEARANCE 2 inch (51 mm) 22G44 (US) 3 inch (76 mm) 44J40 (US)

See Installation Instructions for additional information.

Note - Field provided reducer may be required to adapt larger vent pipe size to termination.

If Intake and Exhaust Pipe is less than 12 in. (305 mm) above snow accumulation or other obstructions, field fabricated piping must be installed.

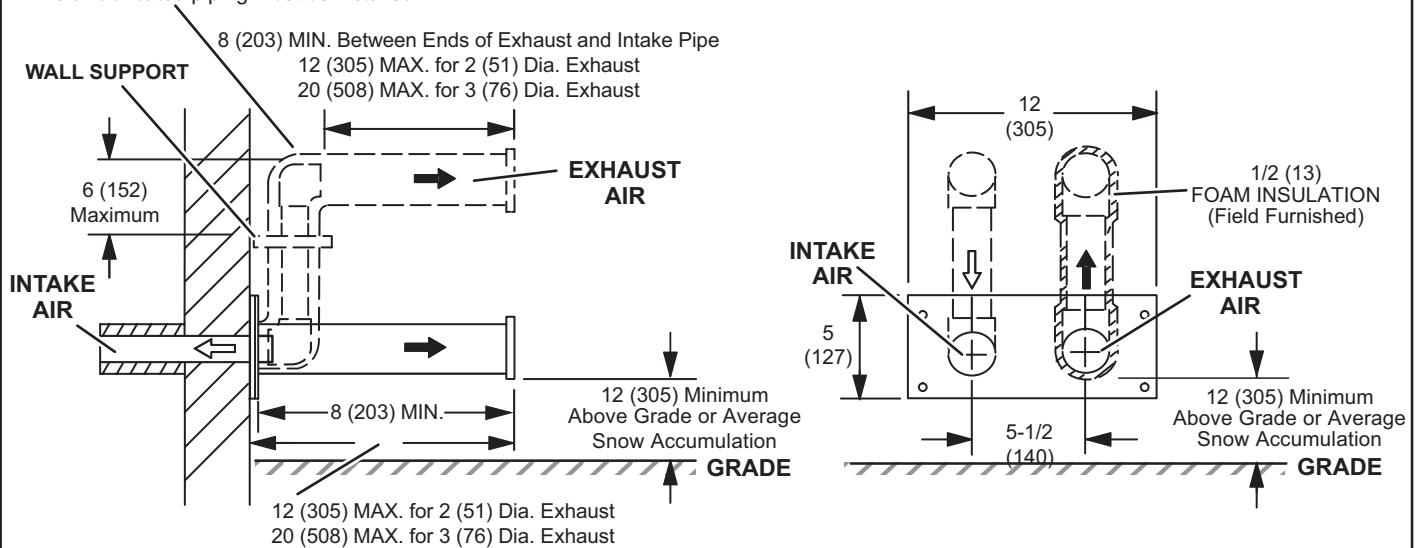

### WALL TERMINATION KITS (CLOSE-COUPLE) EXTENDED VENT FOR GRADE CLEARANCE 2 inch (51 mm) 30G28 (WTK Canada) 3 inch (76 mm) 81J20 (WTK Canada)

See Installation Instructions for additional information.

Note - Field provided reducer may be required to adapt larger vent pipe size to termination.

If Intake and Exhaust Pipe is less than 12 in. (305 mm) above snow accumulation or other obstructions, field fabricated piping must be installed.

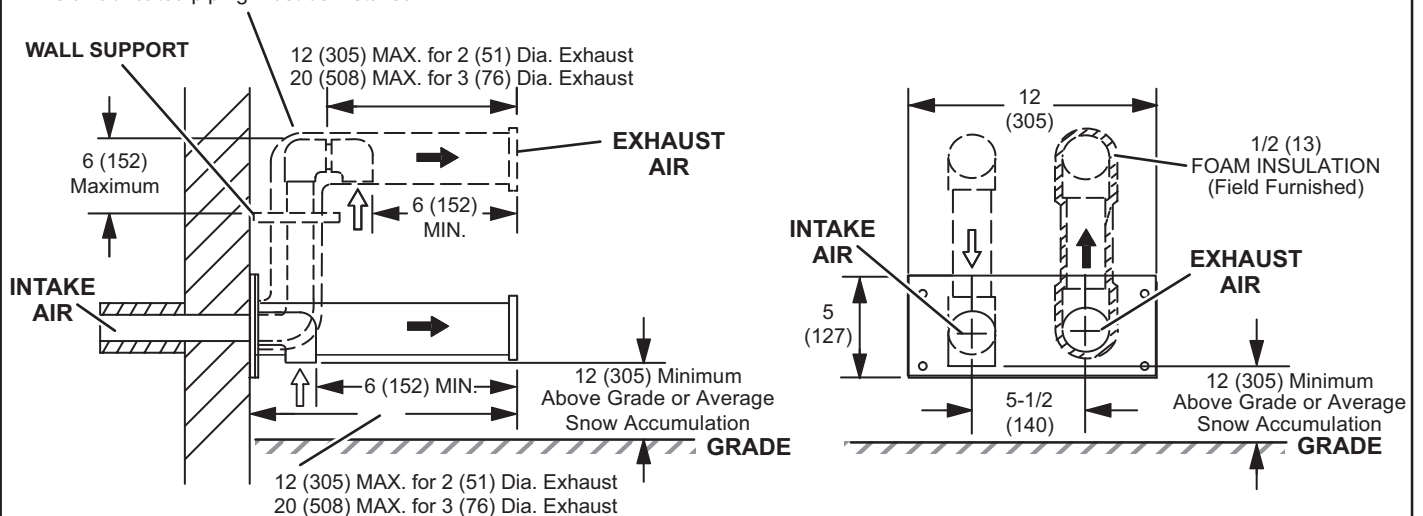

## BLOWER DATA

**ML193UH045XP24B PERFORMANCE (Less Filter)**

External Static Pressure in. w.g.	Air Volume / Watts at Various Blower Speeds							
	High		Medium-High		Medium-Low		Low	
	cfm	Watts	cfm	Watts	cfm	Watts	cfm	Watts
0.00	1140	455	920	365	765	295	710	265
0.10	1135	445	900	360	765	290	690	255
0.20	1125	430	895	350	755	285	680	255
0.30	1090	415	870	340	725	280	660	250
0.40	1065	405	870	325	715	270	635	245
0.50	1020	390	825	315	675	260	605	235
0.60	945	365	780	300	640	250	555	225
0.70	910	350	740	295	585	240	505	220
0.80	790	325	670	275	510	225	455	205
0.90	735	310	575	255	460	220	390	195

**ML193UH090XP36C PERFORMANCE (Less Filter)**

External Static Pressure in. w.g.	Air Volume / Watts at Various Blower Speeds							
	High		Medium-High		Medium-Low		Low	
	cfm	Watts	cfm	Watts	cfm	Watts	cfm	Watts
0.00	1620	745	1340	620	1130	500	965	405
0.10	1610	720	1335	595	1135	490	975	395
0.20	1565	695	1335	565	1145	465	970	385
0.30	1525	665	1300	555	1135	455	970	370
0.40	1485	635	1295	520	1110	435	960	355
0.50	1431	600	1260	495	1090	405	940	345
0.60	1365	570	1210	475	1035	390	900	330
0.70	1295	535	1155	445	995	365	860	305
0.80	1200	505	1065	415	930	340	745	270
0.90	1060	460	955	375	820	305	695	260

**ML193UH045XP36B PERFORMANCE (Less Filter)**

External Static Pressure in. w.g.	Air Volume / Watts at Various Blower Speeds							
	High		Medium-High		Medium-Low		Low	
	cfm	Watts	cfm	Watts	cfm	Watts	cfm	Watts
0.00	1600	700	1370	590	1160	475	1005	400
0.10	1600	685	1355	565	1155	465	1015	390
0.20	1550	650	1330	540	1150	445	1000	380
0.30	1480	625	1295	515	1140	430	975	365
0.40	1425	590	1280	490	1105	415	975	350
0.50	1355	565	1190	460	1085	395	940	335
0.60	1320	545	1165	435	1030	375	900	315
0.70	1225	500	1110	425	975	355	855	310
0.80	1135	480	1050	395	920	330	780	280
0.90	1025	445	950	360	800	295	700	255

**ML193UH090XP48C PERFORMANCE (Less Filter)**

External Static Pressure in. w.g.	Air Volume / Watts at Various Blower Speeds							
	High		Medium-High		Medium-Low		Low	
	cfm	Watts	cfm	Watts	cfm	Watts	cfm	Watts
0.00	2025	900	1690	780	1395	645	1200	540
0.10	1995	880	1705	760	1390	635	1205	525
0.20	1925	835	1675	715	1405	605	1205	505
0.30	1850	795	1640	680	1400	580	1170	490
0.40	1790	760	1575	645	1395	560	1170	475
0.50	1700	725	1540	625	1350	535	1140	450
0.60	1610	690	1455	580	1295	505	1100	430
0.70	1540	645	1365	550	1225	480	1030	405
0.80	1415	615	1265	510	1125	445	980	385
0.90	1270	565	1165	470	1060	420	900	350

**ML193UH070XP24B PERFORMANCE (Less Filter)**

External Static Pressure in. w.g.	Air Volume / Watts at Various Blower Speeds							
	High		Medium-High		Medium-Low		Low	
	cfm	Watts	cfm	Watts	cfm	Watts	cfm	Watts
0.00	1140	455	920	365	765	295	710	265
0.10	1135	445	900	360	765	290	690	255
0.20	1125	430	895	350	755	285	680	255
0.30	1090	415	870	340	725	280	660	250
0.40	1065	405	870	325	715	270	635	245
0.50	1020	390	825	315	675	260	605	235
0.60	945	365	780	300	640	250	555	225
0.70	910	350	740	295	585	240	505	220
0.80	790	325	670	275	510	225	455	205
0.90	735	310	575	255	460	220	390	195

**ML193UH110XP48C PERFORMANCE (Less Filter)**

External Static Pressure in. w.g.	Air Volume / Watts at Various Blower Speeds							
	High		Medium-High		Medium-Low		Low	
	cfm	Watts	cfm	Watts	cfm	Watts	cfm	Watts
0.00	2030	905	1750	805	1425	665	1225	530
0.10	1950	865	1755	770	1430	630	1215	515
0.20	1935	840	1675	735	1455	610	1230	505
0.30	1885	810	1660	685	1410	585	1200	485
0.40	1830	780	1585	645	1385	570	1190	470
0.50	1750	740	1565	630	1320	535	1165	455
0.60	1660	695	1485	585	1280	505	1105	425
0.70	1540	665	1380	555	1230	485	1060	405
0.80	1420	615	1290	520	1140	445	945	375
0.90	1290	575	1175	470	1045	410	850	350

**ML193UH070XP36B PERFORMANCE (Less Filter)**

External Static Pressure in. w.g.	Air Volume / Watts at Various Blower Speeds							
	High		Medium-High		Medium-Low		Low	
	cfm	Watts	cfm	Watts	cfm	Watts	cfm	Watts
0.00	1615	680	1355	570	1140	480	1030	400
0.10	1565	660	1365	545	1150	465	1020	385
0.20	1535	630	1340	525	1150	440	1025	375
0.30	1440	600	1300	500	1110	420	1000	350
0.40	1405	570	1255	470	1075	400	975	345
0.50	1340	535	1200	445	1045	380	945	330
0.60	1255	500	1125	420	995	355	875	310
0.70	1165	475	1080	395	935	335	820	290
0.80	1060	455	990	365	870	315	750	265
0.90	955	425	895	345	750	285	660	245

## BLOWER DATA

### ML193UH110XP60C PERFORMANCE (Less Filter)

External Static Pressure in. w.g.	Air Volume / Watts at Different Blower Speeds															
	Bottom Return Air, Side Return Air with Return Air from Both Sides or Return Air from Bottom and One Side.								Single Side Return Air – Air volumes in <b>bold</b> require Optional Return Air Base <u>and</u> field fabricated transition to accommodate 20 x 25 x 1 in. air filter in order to maintain proper air velocity.							
	High		Medium-High		Medium-Low		Low		High		Medium-High		Medium-Low		Low	
	cfm	Watts	cfm	Watts	cfm	Watts	cfm	Watts	cfm	Watts	cfm	Watts	cfm	Watts	cfm	Watts
0.00	2525	1560	2175	1165	1820	905	1465	725	<b>2520</b>	<b>1545</b>	<b>2135</b>	<b>1150</b>	1750	905	1445	720
0.10	2585	1545	2200	1135	1860	900	1475	710	<b>2555</b>	<b>1545</b>	<b>2135</b>	<b>1115</b>	1775	890	1470	715
0.20	2515	1505	2150	1110	1840	890	1490	705	<b>2465</b>	<b>1480</b>	<b>2105</b>	<b>1085</b>	1775	875	1465	705
0.30	2445	1445	2135	1065	1790	870	1500	690	<b>2370</b>	<b>1430</b>	<b>2045</b>	<b>1055</b>	1750	855	1460	690
0.40	2340	1385	2065	1035	1770	845	1500	675	<b>2275</b>	<b>1375</b>	<b>1990</b>	<b>1010</b>	1730	830	1460	680
0.50	2230	1350	1985	985	1755	810	1470	665	<b>2185</b>	<b>1345</b>	<b>1930</b>	<b>970</b>	1690	800	1460	655
0.60	2130	1295	1920	950	1685	785	1425	640	<b>2060</b>	<b>1290</b>	<b>1850</b>	<b>935</b>	1650	780	1420	635
0.70	2030	1250	1815	905	1640	760	1405	625	<b>1930</b>	<b>1230</b>	1760	900	1580	750	1355	610
0.80	1920	1190	1735	865	1560	725	1350	605	<b>1825</b>	<b>1180</b>	1660	855	1505	710	1290	585
0.90	1735	1135	1620	830	1450	685	1270	575	1665	1130	1520	810	1415	675	1210	560

### ML193UH135XP60D PERFORMANCE (Less Filter)

External Static Pressure in. w.g.	Air Volume / Watts at Different Blower Speeds															
	Bottom Return Air, Side Return Air with Return Air from Both Sides or Return Air from Bottom and One Side.								Single Side Return Air – Air volumes in <b>bold</b> require Optional Return Air Base <u>and</u> field fabricated transition to accommodate 20 x 25 x 1 in. air filter in order to maintain proper air velocity.							
	High		Medium-High		Medium-Low		Low		High		Medium-High		Medium-Low		Low	
	cfm	Watts	cfm	Watts	cfm	Watts	cfm	Watts	cfm	Watts	cfm	Watts	cfm	Watts	cfm	Watts
0.00	2800	1715	2155	1160	1730	900	1375	695	<b>2720</b>	<b>1685</b>	<b>2110</b>	<b>1135</b>	1670	905	1355	705
0.10	2770	1665	2170	1145	1740	895	1415	700	<b>2660</b>	<b>1650</b>	<b>2110</b>	<b>1115</b>	1725	895	1390	700
0.20	2690	1635	2150	1110	1770	890	1450	700	<b>2600</b>	<b>1585</b>	<b>2125</b>	<b>1090</b>	1750	885	1450	695
0.30	2590	1560	2140	1080	1785	870	1455	695	<b>2535</b>	<b>1525</b>	<b>2075</b>	<b>1065</b>	1750	865	1465	685
0.40	2500	1535	2105	1055	1785	855	1475	690	<b>2400</b>	<b>1490</b>	<b>2055</b>	<b>1030</b>	1715	845	1460	680
0.50	2420	1465	2050	1025	1770	835	1465	665	<b>2335</b>	<b>1420</b>	<b>2000</b>	<b>1005</b>	1725	825	1455	660
0.60	2330	1410	2015	995	1720	810	1460	655	<b>2270</b>	<b>1385</b>	<b>1950</b>	<b>970</b>	1720	800	1445	650
0.70	2225	1370	1965	960	1690	785	1450	650	<b>2175</b>	<b>1335</b>	<b>1895</b>	<b>950</b>	1665	780	1430	635
0.80	2150	1335	1875	925	1655	755	1435	630	<b>2075</b>	<b>1295</b>	<b>1840</b>	<b>910</b>	1605	745	1400	620
0.90	2025	1290	1830	890	1575	720	1375	605	<b>1975</b>	<b>1255</b>	1755	875	1540	725	1340	590







## REVISIONS

Sections	Description of Change
Controls	Added iComfort® M30 Smart Thermostat and Remote Outdoor Temperature Sensor.
Optional Accessories	Added Flue Coupling.



Visit us at [www.lennox.com](http://www.lennox.com)

For the latest technical information, [www.LennoxPROs.com](http://www.LennoxPROs.com)

Contact us at 1-800-4-LENNOX

NOTE - Due to Lennox' ongoing commitment to quality, Specifications, Ratings and Dimensions subject to change without notice and without incurring liability. Improper installation, adjustment, alteration, service or maintenance can cause property damage or personal injury. Installation and service must be performed by a qualified installer and servicing agency.

©2019 Lennox Industries, Inc.