



# GAS FURNACES

## ML193UHE

### MERIT® SERIES

Upflow / Horizontal - Constant Torque Blower - 60Hz

#### RESIDENTIAL PRODUCT SPECIFICATIONS

Bulletin No. 210867  
April 2021  
Supersedes July 2020



## MERIT® SERIES



**QUALIFIED ONLY IN**  
**U.S. SOUTH:** AL, AZ, AR, CA, DC, DE, FL, GA, HI, KY, LA, MD, MS, NV, NM, NC, OK, SC, TN, TX, VA



QUALIFIED

**AFUE - 93%**  
**Input - 30,000 to 110,000 Btuh**  
**Nominal Add-on Cooling - 3 to 5 Tons**

#### MODEL NUMBER IDENTIFICATION

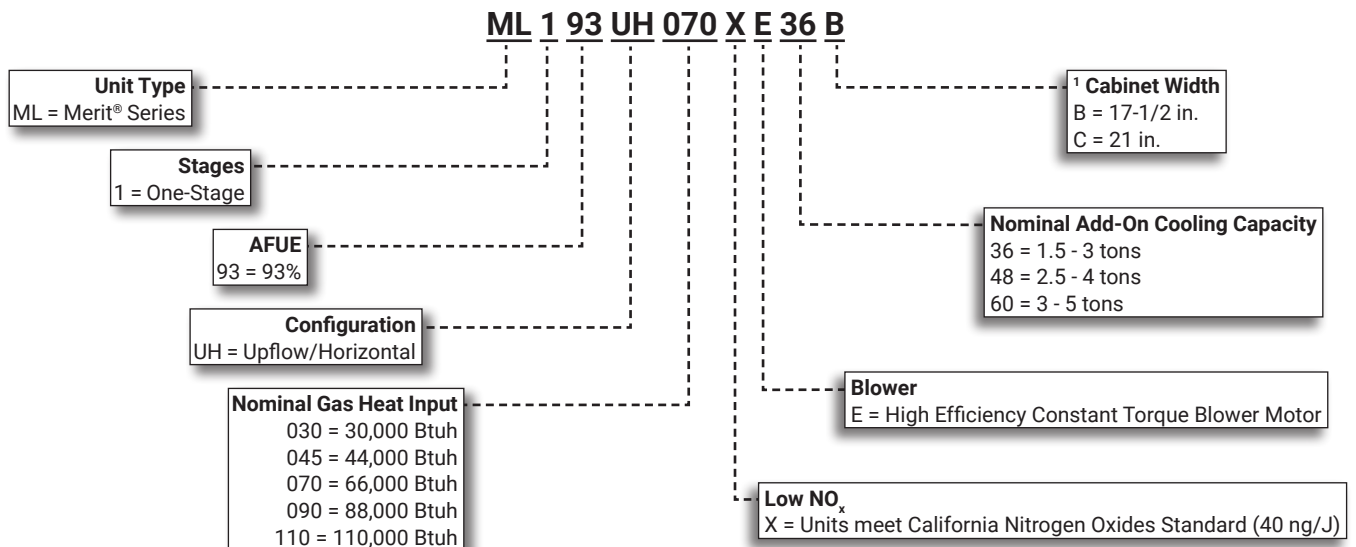

<sup>1</sup> Indoor coils with the same letter designation will physically match the furnace.

## FEATURE HIGHLIGHTS

1. Lennox Duralok Plus™ Heat Exchanger
2. Secondary Heat Exchanger
3. Inshot Burners
4. Gas Control Valve
5. Flame Rollout Switch
6. Combustion Air Inducer
7. SureLight® Integrated Furnace Control
8. Power Saver™ Constant Torque Blower
9. Insulated Cabinet
10. Safety Interlock Switch
11. Gas Piping And Electrical Inlets



## CONTENTS

Blower Data . . . . .	21
Approvals And Warranty . . . . .	3
Dimensions . . . . .	14
- Unit - Upflow Position . . . . .	14
- Unit - Horizontal Position . . . . .	15
- Optional Accessories . . . . .	16
- Optional Accessories - Venting. . . . .	17
- Furnace/Coil Combined Dimensions . . . . .	20
Features . . . . .	3
Gas Heat Accessories . . . . .	10
High Altitude Derate . . . . .	10
Installation Clearances . . . . .	10
Model Number Identification. . . . .	1
Optional Accessories . . . . .	11
Specifications . . . . .	9
Vent Lengths . . . . .	13

## APPROVALS AND WARRANTY

### APPROVALS

- AHRI Certified
- Tested and rated according to US DOE test procedures and FTC labeling regulations
- Approved by the California Energy Commission and meets California Nitrogen Oxides Standard (NOx) limits of 40 ng/J
- ENERGY STAR® units are certified only in the U.S. South in certain states and are designed to use less energy, help save money on utility bills, and help protect the environment
- ISO 9001 Registered Manufacturing Quality System
- Blower data from unit tests conducted in Lennox Laboratory air test chamber

### California Only

- These furnaces **do not meet** the South Coast Air Quality Management District (SCAQMD) Rule 1111 and San Joaquin Valley Air Pollution Control District (SJVAPCD) Rule 4905 NOx emission limit (14 ng/J) and cannot be installed within the SCAQMD and SJVAPCD areas
- These furnaces are approved by the California Energy Commission and meets California Nitrogen Oxides Standard (NOx) limits of 40 ng/J

### WARRANTY

- Duralok Plus™ Aluminized Steel Heat Exchanger:
  - Limited twenty year in residential applications
  - Limited ten years in non-residential applications
- All other covered components:
  - Limited five years in residential installations
  - Limited one year in non-residential installations

**NOTE** - Refer to Lennox Equipment Limited Warranty certificate included with unit for specific details.

## FEATURES

### APPLICATIONS

- Input capacities of 30,000, 44,000, 66,000, 88,000 and 110,000 Btuh
- Energy efficiency (AFUE) - 93%
- Compact cabinet for upflow, horizontal-left or horizontal-right applications without any modifications
- Lennox add-on indoor coils, high-efficiency air cleaners and humidifiers can easily be added to furnace
- Shipped factory assembled with all controls installed and wired
- Factory test operated to ensure proper operation.

### HEATING SYSTEM

- 1 **Lennox Duralok Plus™ Heat Exchanger Assembly**
  - Lennox developed heat exchanger assembly consists of primary heat exchanger and secondary condenser coil assembly
  - Main multi-pass crimped seam design clamshell type
  - Constructed of heavy-gauge, aluminized steel
  - Designed for normal expansion and contraction with maximum efficiency and minimum resistance to air flow

- 2
  - Secondary heat exchanger condenser coil constructed of aluminum fins fitted to stainless steel tubes
  - Coil is factory tested for leaks
  - Condensate drain header box assembly located on front of coil
  - Compact size permits low overall design of furnace cabinet
  - Laboratory life cycle tested in excess of industry standards

### **Lennox Designed Header Box**

- Header box on end of condenser coil collects flue condensate for disposal through condensate drains
- Drains are located on each side of the cabinet for easy field installation of condensate drain trap
- Only one drain is used, the other drain is sealed
- Condensate drain trap is included with the unit for field installation

## FEATURES

### HEATING SYSTEM (continued)

#### Lennox Designed Flue Condensate Trap Assembly

- Field installed outside the conditioned air stream
- Assembly can be mounted on either side of cabinet in upflow applications
- Assembly is mounted below the cabinet in horizontal applications
- Can also be mounted remotely (up to 5 ft. away) from unit
- See Dimension Drawing and Installation Instructions
- 90° street elbow furnished for ease of drain trap installation
- Drain connection can be made with field provided PVC pipe or PVC coupling
- Drain cap on trap allows easy cleaning and winterizing

### 3 Inshot Burners

- Aluminized steel inshot burners provide efficient, trouble-free operation
- Burner venturi mixes air and gas in correct proportion for proper combustion
- Burner assembly can be removed from the unit as a single component for ease of service

#### SureLight® Hot Surface Ignitor

- Tough, reliable, long-life, trouble-free performance
- Silicon nitride ignitor
- Cemented to steatite block for protection against current leakage
- Ignition leads are constructed of nickel plated copper and are enclosed in high temperature Teflon® insulation for dependable operation

### 4 Gas Control Valve

- 24 volt redundant combination gas control valve combines manual shut off switch (On-Off), automatic electric valve (dual) and gas pressure regulation into a compact combination control

### 5 Flame Rollout Switches (2)

- Factory installed on the front of the burner box
- Switch provides protection from abnormal operating conditions
- Manual reset

#### Limit Control

- Primary limit is accurately located on header box on all units
- Automatic reset

### 6 Combustion Air Inducer

- Shaded pole heavy duty blower prepurges heat exchanger and safely vents flue products
- Operates only during heating cycle

#### Pressure Switch

- Proves Combustion Air Inducer operation before allowing gas valve to open

### Optional Accessories

#### High Altitude Orifice Kits

- Required on all units for proper operation at altitudes from 7501 to 10,000 ft.
- Kits are available for natural gas and LPG/propane

#### High Altitude Pressure Switch Kit

- Required for proper unit operation on installations above 4500 ft.

#### Natural Gas to LPG/Propane Conversion Kit

- Required for field changeover from natural gas to LPG/Propane

#### LPG/Propane to Natural Gas Conversion Kit

- Required for field changeover from LPG/Propane to natural gas

#### Muffler (US Only)

- Significantly reduces outdoor operating sound levels
- Two-inch diameter muffler is optional for 030 through 110 input models

**NOTE** - Two-inch muffler is optional for the 110 input model with a maximum vent pipe length of up to 29 ft.  
Three-inch diameter muffler is optional for 110 input model.

**NOTE** - Three-inch muffler is optional for the 110 input model with a minimum vent pipe length of 30 ft.

- Installed vertically in the exhaust piping
- See Optional Accessory Dimension Drawing

### DIRECT VENT / NON-DIRECT VENT SEALED COMBUSTION SYSTEM

- Furnace features a "sealed combustion" system and can be installed in either Direct Vent or Non-Direct applications
- In Direct Vent applications, combustion air is supplied from outdoors and flue gases are discharged outdoors
- In Non-Direct Vent applications, combustion air is supplied from indoors and flue gases are discharged outdoors

**NOTE** - Lennox has approved the use of DuraVent® PolyPro® and Centrotherm InnoFlue® manufactured vent pipe and terminations as an alternative to PVC vent pipe. Must be ordered separately.  
Tested and listed to the ULC S636 standard in Canada.

- The polypropylene venting system must follow the uninsulated and unconditioned space vent lengths listed in the table on Page 12
- Refer to the Installation Instructions for additional details

## FEATURES

### **DIRECT VENT / NON-DIRECT VENT SEALED COMBUSTION SYSTEM (continued)**

#### **Flue Coupling**

- Assists with exhaust flue piping connection and servicing
- Includes flexible one 2-inch rubber coupling and two adjustable bands
- Approved for all Lennox 90% furnaces

#### **Vent Termination Kits**

- Facilitates installation of combustion air intake pipe and flue exhaust pipe
- Refer to venting table in this bulletin to determine pipe size needed and proper termination kit required
- See Optional Accessories table and dimension drawings

#### **Concentric Termination Kit - Direct Vent Applications**

- 2 or 3 inch kit contains concentric termination assembly, reducer bushing and 45° elbow
- 2 inch kit for -030-045-070 models contains an outdoor exhaust accelerator
- Kit requires single hole penetration of roof or wall for installation
- Roof Termination Flashing Kit is available for use with 2 inch Kits
- CSA certified

#### **Flush-Mount Termination Kit**

- Kit contains flush-mount termination, accelerator, mounting template and hardware
- Kit may be used with 2, 2-1/2 or 3 in. pipe

#### **Wall Assembly Termination Kits**

##### **Close Couple (US Only) - Direct Vent Applications**

- 2 or 3 inch kit consists of close-couple, side-by-side PVC piping with galvanized steel wall cover plate
- Seals and isolates intake and exhaust piping penetration of wall
- Piping spacing and length is sized for proper wall installations
- CSA certified

##### **Close Couple WTK (Canada Only) - Direct Vent Applications**

- 2 or 3 inch kit contains one insulated faceplate, one insulated exhaust pipe, elbow and fittings

**NOTE** - Maintain a maximum of 6 inches between the inlet and outlet openings in the installation of the pipes.

#### **Roof Termination Flashing Kit**

- For vertical venting through a roof
- 2 or 3 inch kit contains two neoprene rubber roof flashings
- Vent pipe and insulation not furnished
- Flashing Kit can also be used with Concentric Vent Termination Kits used in vertical venting rooftop applications

### **CONTROLS**

#### **7 SureLight® Integrated Furnace Control**

- Contains all necessary controls and relays to operate furnace
- Combustion air inducer is operated by the integrated furnace control
- Prior to ignition, a pre-purge cycle for 15 seconds is initiated
- After the main burners are turned off, a post-purge cycle for 5 seconds is run
- Flame sensor assures safe and reliable operation
- Should loss of flame occur, the integrated furnace control will initiate 4 re-attempts at ignition before locking out unit operation for 60 minutes
- Watchguard type circuit automatically resets ignition controls after one hour of continuous thermostat demand after unit lockout, eliminating nuisance calls for service
- Fan control consists of adjustable blower timed-off delay (60, 90, 120, 180 seconds - factory setting 90 seconds) and fixed blower timed-on delay (30 seconds heating, 2 seconds cooling)
- For air-conditioning applications, blower is automatically energized on thermostat demand for cooling
- Two accessory terminals furnished for additional power supply requirements for 120 volt (less than 1 amp) power humidifiers and powered air cleaners
- One additional terminal is furnished for power supply requirements for 24V (less than 0.5 amp) low voltage accessories
- Ignition control has a single red LED to indicate status and as an aid in troubleshooting
- Last ten codes are stored in non-volatile memory (accessible by recall button on control) for servicing

#### **24 Volt Transformer (40VA)**

- Fuse wired in series
- Furnished and factory installed in control box

#### **Field Wiring Make-Up Box**

- Furnished for line voltage wiring
- Factory installed internally on left side of furnace
- Box may be installed internally or externally on either side of furnace

## FEATURES

### CONTROLS (continued)

#### Optional Accessories

#### iComfort® M30 Smart Wi-Fi Thermostat

- Wi-Fi-enabled, electronic 7-day, universal, multi-stage, programmable, touchscreen thermostat
- 4 Heat/2 Cool
- Auto-changeover
- Dual-fuel control with optional outdoor sensor
- Controls dehumidification during cooling mode and humidification during heating mode
- Offers enhanced capabilities including humidification / dehumidification / dewpoint measurement and control, Humiditol® control, and equipment maintenance reminders
- Easy to read 4.3 in. color touchscreen (measured diagonally)
- LCD display with backlight shows the current and set temperature, time, inside relative humidity, system status (operating mode and schedules) and outside temperature (optional outdoor sensor required)
- Smooth Setback Recovery starts system early to achieve setpoint at start of program period
- Compressor short-cycle protection (5 minutes)
- Up to four separate schedules are available plus Schedule IQ™
- One-Touch Away Mode - A quick and easy way to set the cooling and heating setpoints while away
- Smart Away™ - Uses geo-fencing technology to determine when the homeowner is within a predetermined distance from the home to operate the system when leaving, away and arriving
- Wi-Fi remote monitoring and adjustment through a home wireless network for desktop PCs, laptops and apps for smartphones or tablets
- Smart home automation compatible with Amazon Alexa®, Google Assistant and IFTTT
- Service Dashboard features online real-time monitoring of installed iComfort® thermostats

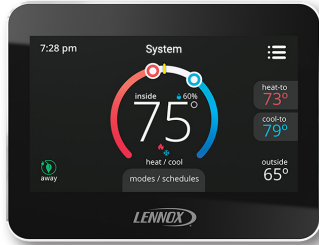

#### Thermostat

- Thermostat is not furnished with unit
- See Lennox Price Book for selection

#### Blower Relay Kit (For Use With Two-Stage Outdoor Units)

- Allows furnace blower speed changes when matched with two-stage air conditioners or heat pumps

#### Furnace Twinning Kit

- Required to operate two furnaces simultaneously
- Kit consists of twinning relays, quick connect terminals and mounting hardware
- Used for single-stage heating/single-stage cooling with a single-stage thermostat

#### Night Service Kit

- Contains most commonly used service parts:
  - Furnace Control
  - Igniter
  - Flame Sensor
  - Gas Valve
  - Transformer
  - Service Manual

#### **BLOWER**

- Direct drive blower
- Statically and dynamically balanced
- Resiliently mounted
- Blower assembly easily removed for servicing

#### 8 Power Saver™ Constant Torque Blower Motor

- DC Brushless Motor
- High Efficiency Constant Torque
- ECM (Electronically Commutated Motor)
- Motor is programmed to provide constant torque at each of the selectable speeds
- Motor is controlled by the Integrated Furnace Control
- Blower speeds are easily changed on the integrated furnace control
- See Blower Data tables

**NOTE** - See the iComfort® M30 Smart Wi-Fi Thermostat Product Specifications bulletin in the Controls section for more information.

#### Remote Outdoor Temperature Sensor

- Used with the iComfort® M30 Smart Thermostat
- Outdoor sensor allows thermostat to display outdoor temperature

**NOTE** - Sensor is required for the Enhanced Dehumidification Accessory (EDA).





## FEATURES

### CABINET

- Low-profile, narrow width allows easy installation
- Heavy-gauge, cold rolled steel construction
- Pre-painted cabinet finish
- Flanges provided on supply air opening for ease of plenum connection or alignment with indoor coil
- 9 • Insulated with foil faced insulation on sides and back of heating compartment
- Sealed blower compartment
- Complete service access
- 10 • Safety interlock switch automatically shuts off power to unit when blower compartment access door is removed
- 11 • Gas piping and electrical inlets are provided in both sides of cabinet

### Low Leakage Cabinet

- All models have less than 2% air leakage
- Meets ANSI/ASHRAE Standard 193-2010 "Method of Test for Determining the Air Tightness of HVAC Equipment"

### Bottom/Side Return Air Entry:

- Upflow/horizontal with bottom return air entry:
  - Remove furnished bottom seal panel from cabinet
- Upflow only with side return-air entry:
  - Corners are marked on either side of cabinet for return air cut-out
- See dimension drawings

**NOTE** - 60C size units that require air volumes over 1800 cfm must have one of the following:

- Single side return air and Optional Return Air Base with transition that must accommodate required 20 x 25 x 1 inch air filter to maintain proper velocity
- Bottom return air
- Return air from both sides
- Bottom and one side return air
- See Blower Performance Tables for additional information

### Coil Match-Up

- All furnaces exactly match Lennox cased upflow indoor coils and horizontal indoor coils with same letter designation (A, B, C, D) in model number
- No adaptor required
- Engaging holes furnished on cabinet for alignment
- Lennox uncased coils match furnaces without any overhang but require an optional adaptor base or field fabricated transition to match furnace opening
- See coil bulletin for additional information

### Optional Accessories

#### Condensate Drain Heat Cable Kits

- Self-limiting wattage heat cable prevents condensate drain from freezing in unconditioned areas
- Available in 6 or 24 ft. lengths

#### Horizontal Suspension Kit

- Provides suspension of unit and indoor coil in horizontal applications
- Allows complete service access
- Consists of corner mounted hanging brackets with vibration isolators, return air end support rail and hardware for assembly
- Metal hanging straps must be field provided

#### Crawl Space Vent Drain Kit

- Allows venting through a crawl space for upflow and horizontal applications
- Includes 2 or 3 in. sanitary tee, 2 in. PVC assembly, PVC boot and clamp
- Kit for Canada is certified to ULC S636

#### Return Air Base

**NOTE** - On furnaces with side return air and condensate trap on the same side of the cabinet, a field fabricated transition or Return Air Base is required when using an IAQ product higher than 14-3/16 inches installed next to the unit and serviced from the front. IAQ products higher than 20 inches require a field fabricated transition.

**NOTE** - Must be used for 60C size models with air volumes over 1800 cfm in upflow applications when only one side return is required.

- Cabinet is shipped flat for easy field assembly
- Pre-painted steel to match the furnace
- See Dimension Drawing

#### High Performance Economizer (Commercial Applications Only)

- Designed for applications requiring outdoor air to be utilized in a commercial HVAC system
- Allows the entry of fresh outdoor air for free cooling, reducing the requirement for mechanical cooling
- Heavy gauge galvanized steel cabinet lined with thick fiberglass insulation
- Mixed air sensor, outdoor air sensor and 24VAC transformer furnished
- Approved for California Title 24 building standards
- ASHRAE 90.1-2010 compliant
- See separate Product Specifications bulletin for additional information and available control and sensor options.

## FEATURES

### **FILTER (not furnished)**

- Filter and provisions for external mounting must be field provided

### **Optional Accessories**

#### **Air Filter and Rack Kit for Horizontal Return Air (End)**

##### **Applications**

- Washable or vacuum cleanable polyurethane frame type filter and external end return air rack
- Rack has filter door for servicing
- Flanges on rack for duct connection
- Field installed
- See dimension drawing

#### **Air Filter and Rack Kit for Upflow Side Return Air**

##### **NOTE** - Not for use with Return Air Base

- Washable or vacuum cleanable polyurethane frame type filter and external side return air rack available for field installation
- Available in single and ten pack kits
- Rack has filter door for servicing
- Flanges on rack for duct connection
- Field installs on either side of unit cabinet
- See dimension drawing



## SPECIFICATIONS

Gas	Model No.	ML193UH030XE36B	ML193UH045XE36B	ML193UH070XE36B	ML193UH090XE36C
<b>Heating Performance</b>	AHRI Reference No.	20256877	20256878	20256879	20256880
	<sup>1</sup> AFUE	93%	93%	93%	93%
	Input - Btuh	30,000	44,000	66,000	88,000
	Output - Btuh	29,000	42,000	63,000	84,000
	Temperature rise range - °F	25 - 55	30 - 60	40 - 70	50 - 80
	Gas Manifold Pressure (in. w.g.) Nat. Gas / LPG/Propane	3.5 / 10	3.5 / 10.0	3.5 / 10.0	3.5 / 10
	High static - in. w.g.	0.5	0.5	0.5	0.5
	<b>Connections in.</b>	Intake / Exhaust Pipe (PVC)	2 / 2	2 / 2	2 / 2
Gas pipe size IPS		1/2	1/2	1/2	1/2
Condensate Drain Trap (PVC pipe) - i.d.		3/4	3/4	3/4	3/4
with furnished 90° street elbow		3/4 slip x 3/4 Mipt	3/4 slip x 3/4 Mipt	3/4 slip x 3/4 Mipt	3/4 slip x 3/4 Mipt
with field supplied (PVC coupling) - o.d.		3/4 slip x 3/4 MPT	3/4 slip x 3/4 MPT	3/4 slip x 3/4 MPT	3/4 slip x 3/4 MPT
<b>Indoor Blower</b>	Wheel nom. dia. x width - in.	10 x 8	10 x 8	10 x 8	10 x 8
	Motor Type	DC Brushless	DC Brushless	DC Brushless	DC Brushless
	Motor output - hp	1/2	1/2	1/2	1/2
	Tons of add-on cooling	1.5 - 3	1.5 - 3	1.5 - 3	1.5 - 3
	Air Volume Range - cfm	175 - 1435	355 - 1420	355 - 1430	405 - 1410
<b>Electrical Data</b>	Voltage	120 volts - 60 hertz - 1 phase			
	Blower motor full load amps	6.8	6.8	6.8	6.8
	Maximum overcurrent protection	15	15	15	15
<b>Shipping Data</b>	lbs. - 1 package	120	120	127	144

NOTE - Filters and provisions for mounting are not furnished and must be field provided.

<sup>1</sup> Annual Fuel Utilization Efficiency based on DOE test procedures and according to FTC labeling regulations. Isolated combustion system rating for non-weatherized furnaces.

## SPECIFICATIONS

Gas	Model No.	ML193UH090XE48C	ML193UH110XE48C	ML193UH110XE60C
<b>Heating Performance</b>	AHRI Reference No.	20256881	20256882	20256883
	<sup>1</sup> AFUE	93%	93%	93%
	Input - Btuh	88,000	110,000	110,000
	Output - Btuh	84,000	104,000	105,000
	Temperature rise range - °F	45 - 75	50 - 80	45 - 75
	Gas Manifold Pressure (in. w.g.) Nat. Gas / LPG/Propane	3.5 / 10.0	3.5 / 10	3.5 / 10
	High static - in. w.g.	0.5	0.5	0.5
	<b>Connections in.</b>	Intake / Exhaust Pipe (PVC)	2 / 2	2 / 2
Gas pipe size IPS		1/2	1/2	1/2
Condensate Drain Trap (PVC pipe) - i.d.		3/4	3/4	3/4
with furnished 90° street elbow		3/4 slip x 3/4 Mipt	3/4 slip x 3/4 Mipt	3/4 slip x 3/4 Mipt
with field supplied (PVC coupling) - o.d.		3/4 slip x 3/4 MPT	3/4 slip x 3/4 MPT	3/4 slip x 3/4 MPT
<b>Indoor Blower</b>	Wheel nom. dia. x width - in.	10 x 10	10 x 10	11-1/2 x 10
	Motor Type	DC Brushless	DC Brushless	DC Brushless
	Motor output - hp	3/4	3/4	1
	Tons of add-on cooling	2.5 - 4	2.5 - 4	3 - 5
	Air Volume Range - cfm	830 - 1710	850 - 1750	1085 - 2150
<b>Electrical Data</b>	Voltage	120 volts - 60 hertz - 1 phase		
	Blower motor full load amps	8.4	8.4	10.9
	Maximum overcurrent protection	15	15	15
<b>Shipping Data</b>	lbs. - 1 package	144	156	158

NOTE - Filters and provisions for mounting are not furnished and must be field provided.

<sup>1</sup> Annual Fuel Utilization Efficiency based on DOE test procedures and according to FTC labeling regulations. Isolated combustion system rating for non-weatherized furnaces.

## INSTALLATION CLEARANCES

Sides	<sup>1</sup> 0 inches (0 mm)
Rear	0 inches (0 mm)
Top/Plenum	1 inch (25 mm)
Front	0 inches (0 mm)
Front (service/alcove)	24 inches (610 mm)
Floor	<sup>2</sup> Combustible

NOTE – Air for combustion must conform to the methods outlined in the National Fuel Gas Code (NFPA 54/ANSI-Z223.1) or the National Standard of Canada CAN/CSA-B149.1 Natural Gas and Propane Installation Code\*.

NOTE – In the U.S. flue sizing must conform to the methods outlined in the current National Fuel Gas Code (NFPA 54/ANSI-Z223.1) or applicable provisions of local building codes. In Canada flue sizing must conform to the methods outlined in National Standard of Canada CAN/CSA-B149.1.

<sup>1</sup> Allow proper clearances to accommodate condensate trap and vent pipe installation.

<sup>2</sup> Do not install the furnace directly on carpeting, tile, or other combustible materials other than wood flooring.

## GAS HEAT ACCESSORIES

Input	High Altitude Pressure Switch Kit		Natural Gas to LPG/Propane Kit	LPG/Propane to Natural Gas Kit	Natural Gas High Altitude Orifice Kit	LPG/Propane High Altitude Orifice Kit	Muffler (US Only)
	4501 - 7500 ft.	7501 - 10,000 ft.	0 - 7500 ft.	0 - 7500 ft.	7501 - 10,000 ft.	7501 - 10,000 ft.	
030	11U65	11U66	17H63	N/A	14C90	17H66	15Y66 (2-inch)
045	11U65	11U66	11K49	73W81	73W37	11K44	15Y66 (2-inch)
070	11U65	11U66	11K49	73W81	73W37	11K44	15Y66 (2-inch)
090	11U65	11U66	11K49	73W81	73W37	11K44	15Y66 (2-inch)
110	11U65	11U66	11K49	73W81	73W37	11K44	<sup>2</sup> 15Y66 (2-inch) 16A56 (3-inch)

<sup>2</sup> Two-inch diameter muffler (15Y66) is optional for 110 input model with a maximum vent pipe length of up to 29 ft. Three-inch diameter muffler (16A56) is optional for 110 input model with a minimum vent pipe length of 30 ft.

## HIGH ALTITUDE DERATE

NOTE - Units may be installed at altitudes up to 10,000 ft.

At altitudes above 4501 ft. the unit must be derated to match the manifold pressure information shown below.

Units installed at altitudes of 4501 to 10,000 ft. require a pressure switch change.

Units installed at altitudes of 7501 to 10,000 ft. require an orifice change.

See the Gas Heat Accessories table for ordering information.

NOTE - This is the only permissible derate for these units.

NOTE - In Canada, certification for installations at elevations over 4500 feet is the jurisdiction of local authorities.

Input	Gas	Manifold Pressure in. w.g.					Supply Line Pressure in. w.g.	
		0 - 4500 ft.	4501 - 5500 ft.	5501 - 6500 ft.	6501 - 7500 ft.	7501 - 10,000 ft.	0 - 10,000 ft.	
All Sizes	Natural	3.5	3.3	3.2	3.1	3.5	4.5	13.0
	LPG/Propane	10.0	9.4	9.1	8.9	10.0	11.0	13.0

## OPTIONAL ACCESSORIES

			"B" Width Models	"C" Width Models	
<b>CABINET ACCESSORIES</b>					
Horizontal Suspension Kit - Horizontal only			51W10	51W10	
Return Air Base - Upflow only			50W98	50W99	
High Performance Economizer (Commercial Only)			10U53	10U53	
<b>CONDENSATE DRAIN KITS</b>					
Condensate Drain Heat Cable	6 ft.		26K68	26K68	
	24 ft.		26K69	26K69	
Crawl Space Vent Drain Kit	US		51W18	51W18	
	Canada		15Z70	15Z70	
<b>CONTROLS</b>					
Blower Relay Kit (for two-stage outdoor units)			85W66	85W66	
iComfort® M30 Smart Wi-Fi Thermostat			15Z69	15Z69	
Remote Outdoor Temperature Sensor			X2658	X2658	
Twinning Kit			16W72	16W72	
<b>FILTER KITS</b>					
¹ Air Filter and Rack Kit	Horizontal (end)	Size of filter - in.	87L96 - 18 x 25 x 1	87L97 - 20 x 25 x 1	
	Side Return	Single	44J22	44J22	
		Ten Pack	66K63	66K63	
		Size of filter - in.	16 x 25 x 1	16 x 25 x 1	
<b>NIGHT SERVICE KIT</b>					
Night Service Kit			84W48	84W48	
<b>TERMINATION KITS</b>					
See Installation Instructions for specific venting information.					
Direct Vent	Concentric	US - 2 in.	71M80	69M29	
		3 in.	---	60L46	
		Canada - 2 in.	44W92	44W92	
		3 in.	---	44W93	
		Flush-Mount	US - 2, 2-1/2 or 3 in.	51W11	51W11
			Canada - 2, 2-1/2 or 3 in.	51W12	51W12
	Wall - Close Couple	US - 2 in.	22G44	---	
		3 in.	44J40	44J40	
	Wall - Close Couple WTK	Canada - 2 in.	30G28	---	
		3 in.	81J20	81J20	
	Roof Termination Flashing Kit (no vent pipe - 2 flashings)	2 in.	15F75	15F75	
		3 in.	44J41	44J41	
<b>VENTING</b>					
Flue Coupling		2 in.	17H92	17H92	

¹ Cleanable polyurethane frame type filter.

NOTE - Termination Kits (44W92, 44W93, 30G28, 51W12, 81J20) and Crawl Space Vent Drain Kit (15Z70) are certified to ULC S636 standard for use in Canada only.

## OUTDOOR TERMINATION KIT USAGE

Input Size	Vent Pipe Diameter (in.)	Standard Terminations				Concentric Terminations			
		Flush Mount Kit	Wall Kit		Field Fabricated Exhaust Accelerator Size Required	Concentric Kit			
			2 inch	3 inch		1-1/2 inch	2 inch	3 inch	
		51W11 (US) 5 51W12 (CA)	22G44 (US) 5 30G28 (CA)	44J40 (US) 5 81J20 (CA)		71M80 (US) 5 44W92 (CA)	69M29 (US) 5 44W92 (CA)	60L46 (US) 5 44W93 (CA)	
030/ 045	1 1-1/2	4 YES	YES	2 YES	1-1/2 in.	3 YES	---	---	
	2	4 YES	YES	2 YES	1-1/2 in.	3 YES	---	---	
	2-1/2	4 YES	YES	2 YES	1-1/2 in.	3 YES	---	---	
	3	4 YES	YES	2 YES	1-1/2 in.	3 YES	---	---	
070	1 1-1/2	4 YES	YES	2 YES	1-1/2 in.	3 YES	---	---	
	2	4 YES	YES	2 YES	1-1/2 in.	3 YES	---	---	
	2-1/2	4 YES	YES	2 YES	1-1/2 in.	3 YES	---	---	
	3	4 YES	YES	2 YES	1-1/2 in.	3 YES	---	---	
090	2	4 YES	---	YES	2 in.	---	YES	YES	
	2-1/2	4 YES	---	YES	2 in.	---	YES	YES	
	3	4 YES	---	YES	2 in.	---	YES	YES	
110	2	YES	---	YES	2 in.	---	YES	YES	
	2-1/2	YES	---	YES	2 in.	---	YES	YES	
	3	YES	---	YES	2 in.	---	YES	YES	

NOTE - Standard Terminations do not include any vent pipe or elbows external to the structure.

Any vent pipe or elbows external to the structure must be included in total vent length calculations. See Vent Length Tables.

<sup>1</sup> 2 inch to 1-1/2 inch reducer required, must be field provided.

<sup>2</sup> Requires field provided 1-1/2 in. outdoor exhaust accelerator.

<sup>3</sup> Concentric Kits **71M80** and **44W92** include 1-1/2 in. outdoor exhaust accelerator, required when used with 030, 045 and 070 input models. Accelerator is not used with 090 or 110 input models. When using 1-1/2 in. piping, the pipe must be transitioned to 2 in. pipe when used with the Concentric Kit.

<sup>4</sup> Flush Mount Kit **51W11** and **51W12** includes 1-1/2 in. outdoor exhaust accelerator, required when used with 030, 045, 070 and 090 input models. Accelerator is not used with 110 input models. When using 1-1/2 in. piping, the pipe must be transitioned to 2 in. pipe when used with the Flush Mount Kit.

<sup>5</sup> Termination Kits **30G28**, **44W92**, **44W93**, **51W12** and **81J20** are certified to ULC S636 standard for use in Canada only.

## VENT LENGTHS - UNINSULATED EXHAUST PIPE IN UNCONDITIONED SPACE

1 Winter Design Temperatures	Vent Pipe Diameter	Unit Input Size									
		030		045		070		090		110	
		Maximum Uninsulated Exhaust Vent Length (ft.)									
		PVC	PolyPro InnoFlue	PVC	PolyPro InnoFlue	PVC	PolyPro InnoFlue	PVC	PolyPro InnoFlue	PVC	PolyPro InnoFlue
32 to 21°F	1-1/2 in.	N/A	N/A	25	N/A	25	N/A	N/A	N/A	N/A	N/A
	2 in.	N/A	N/A	18	16	31	28	50	48	30	30
	2-1/2 in.	N/A	N/A	13	N/A	24	N/A	42	N/A	56	N/A
	3 in.	N/A	N/A	9	9	18	18	35	35	47	47
20 to 1°F	1-1/2 in.	N/A	N/A	15	N/A	20	N/A	N/A	N/A	N/A	N/A
	2 in.	N/A	N/A	9	8	18	16	32	29	30	30
	2-1/2 in.	N/A	N/A	5	N/A	13	N/A	24	N/A	34	N/A
	3 in.	N/A	N/A	N/A	N/A	8	8	19	19	26	26
0 to -20°F	1-1/2 in.	N/A	N/A	10	N/A	15	N/A	N/A	N/A	N/A	N/A
	2 in.	N/A	N/A	5	N/A	12	10	22	19	30	27
	2-1/2 in.	N/A	N/A	N/A	N/A	7	N/A	15	N/A	22	N/A
	3 in.	N/A	N/A	N/A	N/A	N/A	N/A	10	10	16	16

NOTE - Concentric terminations are equivalent to 5 ft. of straight pipe and should be included when measuring total pipe length.

<sup>1</sup> Refer to 99% Minimum Design Temperature table provided in the current edition of the ASHRAE Handbook-Fundamentals.

PolyPro® poly-propylene vent pipe is a registered trademark of DuraVent®.

InnoFlue® is a registered trademark of Centrotherm Eco Systems.

## VENT LENGTHS

### STANDARD TERMINATION AT ELEVATION 0 - 10,000 ft.

Pipe Size	1-1/2 in.				2 in.				2-1/2 in.				3 in.				
	Input	030/045	070	090	110	030/045	070	090	110	030/045	070	090	110	030/045	070	090	110
No. of 90 ELL	1	25	20	N/A	N/A	81	66	44	24	115	100	68	43	137	137	118	118
	2	20	15	N/A	N/A	76	61	39	19	110	95	63	38	132	132	113	113
	3	15	10	N/A	N/A	71	56	34	14	105	90	58	33	127	127	108	108
	4	10	N/A	N/A	N/A	66	51	29	N/A	100	85	53	28	122	122	103	103
	5	N/A	N/A	N/A	N/A	61	46	24	N/A	95	80	48	23	117	117	98	98
	6	N/A	N/A	N/A	N/A	56	41	19	N/A	90	75	43	18	112	112	93	93
	7	N/A	N/A	N/A	N/A	51	36	14	N/A	85	70	38	13	107	107	88	88
	8	N/A	N/A	N/A	N/A	46	31	N/A	N/A	80	65	33	N/A	102	102	83	83
	9	N/A	N/A	N/A	N/A	41	26	N/A	N/A	75	60	28	N/A	97	97	78	78
	10	N/A	N/A	N/A	N/A	36	21	N/A	N/A	70	55	23	N/A	92	92	73	73

### CONCENTRIC TERMINATION ELEVATION 0 - 10,000 ft.

Pipe Size	1-1/2 in.				2 in.				2-1/2 in.				3 in.				
	Input	030/045	070	090	110	030/045	070	090	110	030/045	070	090	110	030/045	070	090	110
No. of 90 ELL	1	20	15	N/A	N/A	73	58	42	22	105	90	64	39	121	121	114	114
	2	15	10	N/A	N/A	68	53	37	17	100	85	59	34	116	116	109	109
	3	10	N/A	N/A	N/A	63	48	32	12	95	80	54	29	111	111	104	104
	4	N/A	N/A	N/A	N/A	58	43	27	N/A	90	75	49	24	106	106	99	99
	5	N/A	N/A	N/A	N/A	53	38	22	N/A	85	70	44	19	101	101	94	94
	6	N/A	N/A	N/A	N/A	48	33	17	N/A	80	65	39	14	96	96	89	89
	7	N/A	N/A	N/A	N/A	43	28	12	N/A	75	60	34	N/A	91	91	84	84
	8	N/A	N/A	N/A	N/A	38	23	N/A	N/A	70	55	29	N/A	86	86	79	79
	9	N/A	N/A	N/A	N/A	33	18	N/A	N/A	65	50	24	N/A	81	81	74	74
	10	N/A	N/A	N/A	N/A	28	13	N/A	N/A	60	45	19	N/A	76	76	69	69

NOTES - Additional vent pipe and elbows used to terminate vent pipe outside the structure must be included in the total vent length calculation.  
 Intake and exhaust pipes are sized separately.  
 Values in table are for separate intake or exhaust pipe lengths.  
 Both intake and exhaust pipe must be the same size diameter.

## VENT LENGTHS (EXHAUST) - VENTILATED ATTIC OR CRAWLSPACE INTAKE AIR - FEET

### STANDARD TERMINATION AT ELEVATION 0 - 10,000 ft.

Pipe Size	1-1/2 in.				2 in.				2-1/2 in.				3 in.				
	Input	030/045	070	090	110	030/045	070	090	110	030/045	070	090	110	030/045	070	090	110
No. of 90 ELL	1	20	15	N/A	N/A	71	56	34	14	100	100	78	43	118	117	98	98
	2	15	10	N/A	N/A	66	51	29	9	95	95	73	38	113	112	93	93
	3	10	N/A	N/A	N/A	61	46	24	4	90	90	68	33	108	107	88	88
	4	N/A	N/A	N/A	N/A	56	41	19	N/A	85	85	63	28	103	102	83	83
	5	N/A	N/A	N/A	N/A	51	36	14	N/A	80	80	58	23	98	97	78	78
	6	N/A	N/A	N/A	N/A	46	31	9	N/A	85	75	63	18	93	92	73	73
	7	N/A	N/A	N/A	N/A	41	26	4	N/A	70	70	48	13	88	87	68	68
	8	N/A	N/A	N/A	N/A	36	21	N/A	N/A	65	65	43	8	83	82	63	63
	9	N/A	N/A	N/A	N/A	31	16	N/A	N/A	60	60	38	3	78	77	58	58
	10	N/A	N/A	N/A	N/A	26	11	N/A	N/A	55	55	33	N/A	73	72	53	53

NOTES - Additional vent pipe and elbows used to terminate vent pipe outside the structure must be included in the total vent length calculation.

# DIMENSIONS

# UNIT - UPFLOW POSITION

- <sup>1</sup> NOTE - 60C size units that require air volumes over 1800 cfm must have one of the following:
1. Single side return air and Optional Return Air Base with transition that must accommodate required 20 x 25 x 1 inch (508 x 635 x 25 mm) air filter to maintain proper velocity.
  2. Bottom return air.
  3. Return air from both sides.
  4. Bottom and one side return air.
- See Blower Performance Tables for additional information.

<sup>2</sup> Optional Side Return Air Filter Kit is not for use with the Optional Return Air Base.

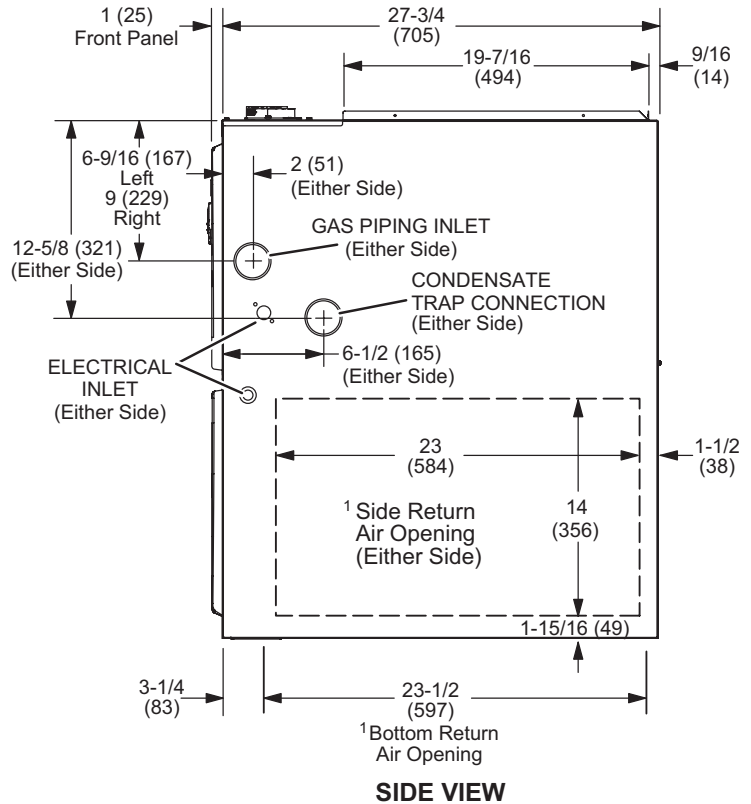
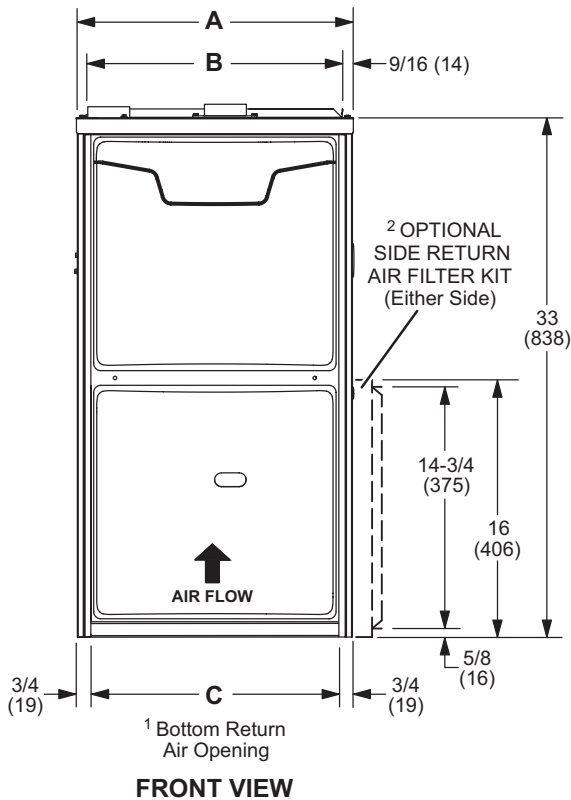
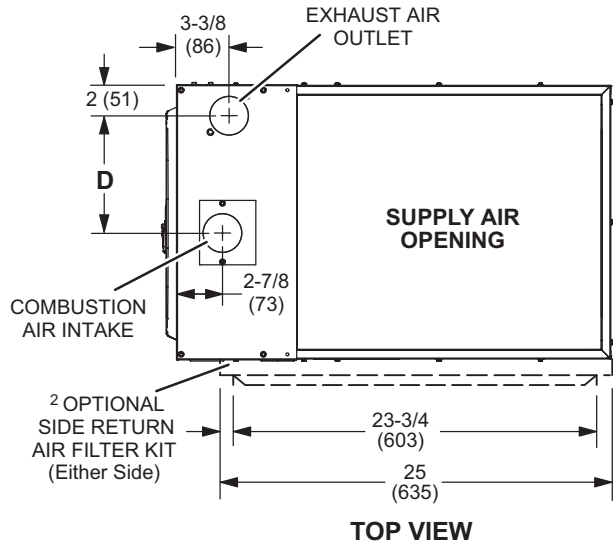
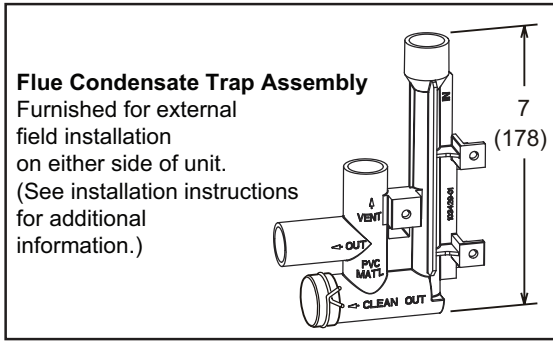

Model No.	A		B		C		D	
	in.	mm	in.	mm	in.	mm	in.	mm
ML193UH030XE36B ML193UH045XE36B ML193UH070XE36B	17-1/2	446	16-3/8	416	16	406	7-5/8	194
ML193UH090XE36C ML193UH090XE48C ML193UH110XE48C ML193UH110XE60C	21	533	19-7/8	505	19-1/2	495	9-3/8	238



**LEFT-HAND AIR DISCHARGE**

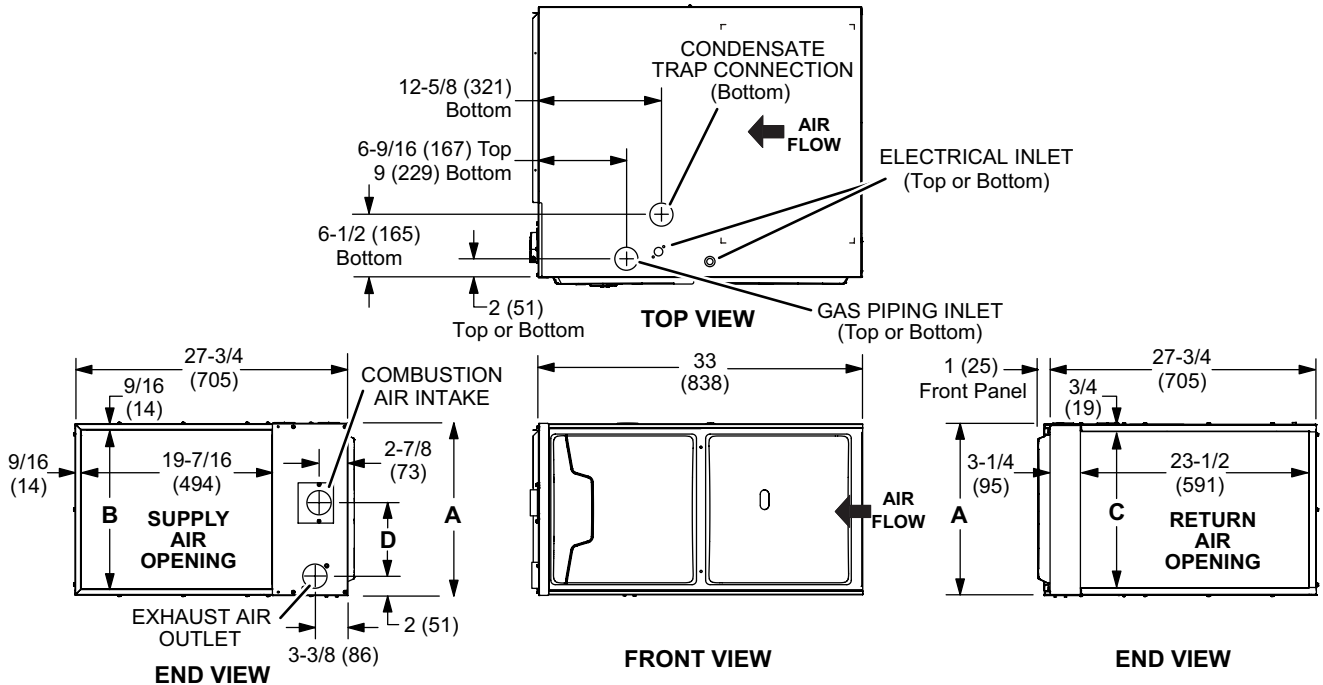

**RIGHT-HAND AIR DISCHARGE**

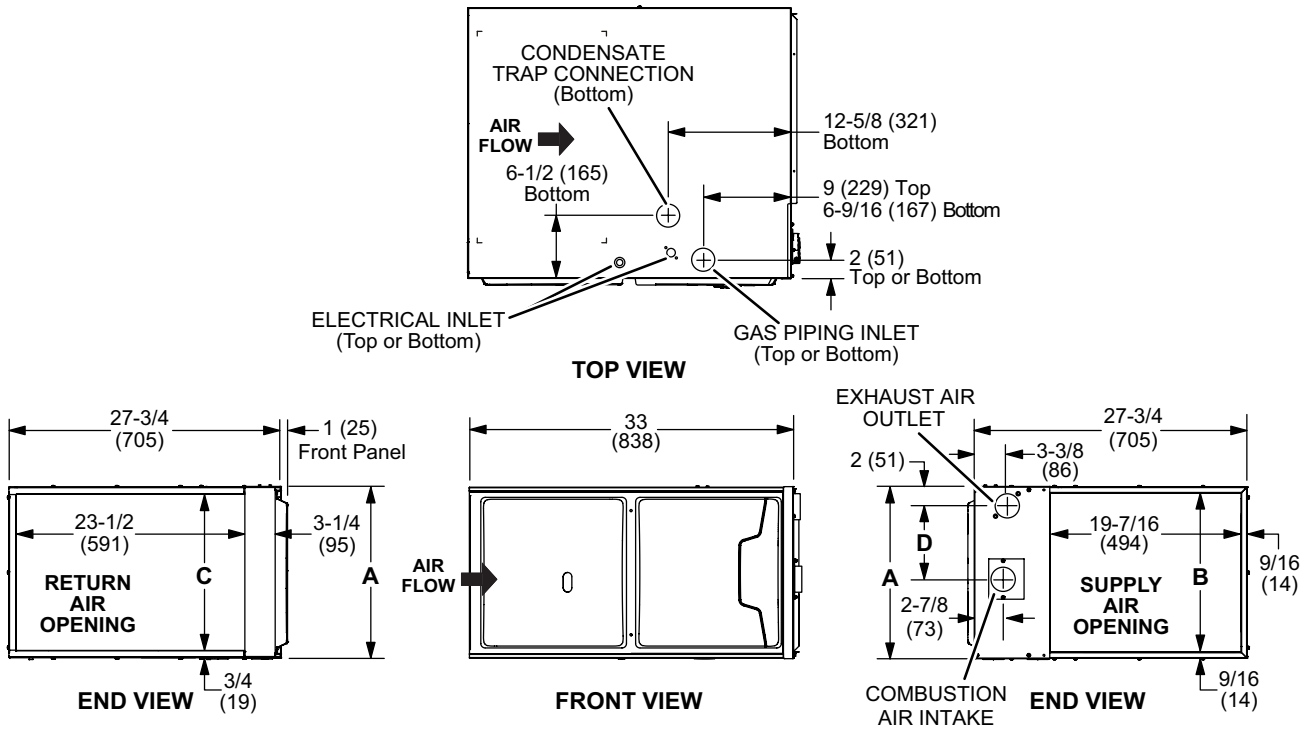

Model No.	A		B		C		D	
	in.	mm	in.	mm	in.	mm	in.	mm
ML193UH030XE36B	17-1/2	446	16-3/8	416	16	406	7-5/8	194
ML193UH045XE36B								
ML193UH070XE36B								
ML193UH090XE36C	21	533	19-7/8	505	19-1/2	495	9-3/8	238
ML193UH090XE48C								
ML193UH110XE48C								
ML193UH110XE60C								

**HORIZONTAL (END) FILTER KIT**

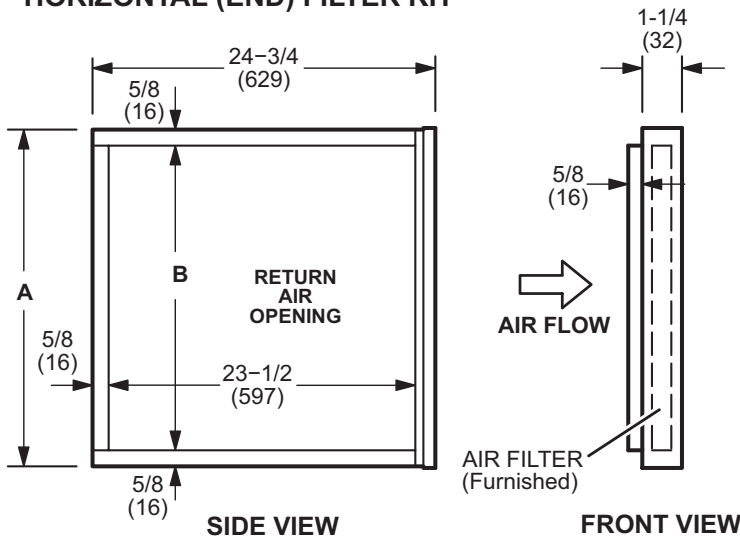

Furnace Cabinet Width	Catalog Number	A		B	
		in.	mm	in.	mm
B	87L96	18	457	16-3/4	425
C	87L97	21	533	18-3/4	476

**OPTIONAL RETURN AIR BASE**  
(Upflow Applications Only - For use with B and C width cabinets)

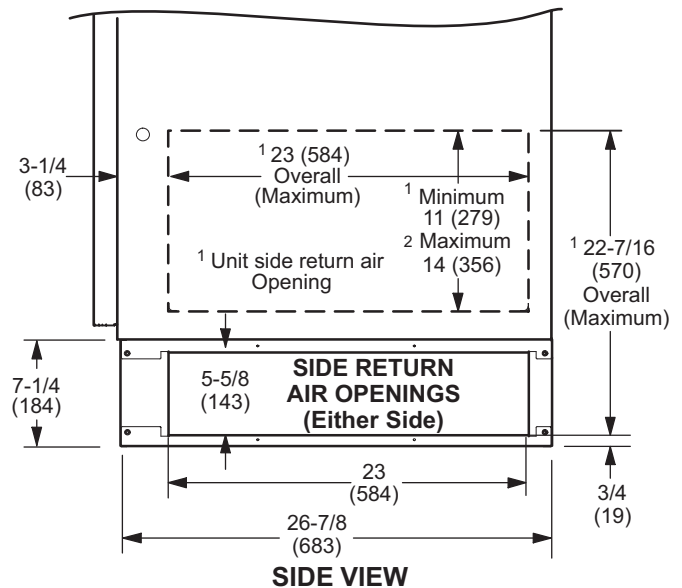
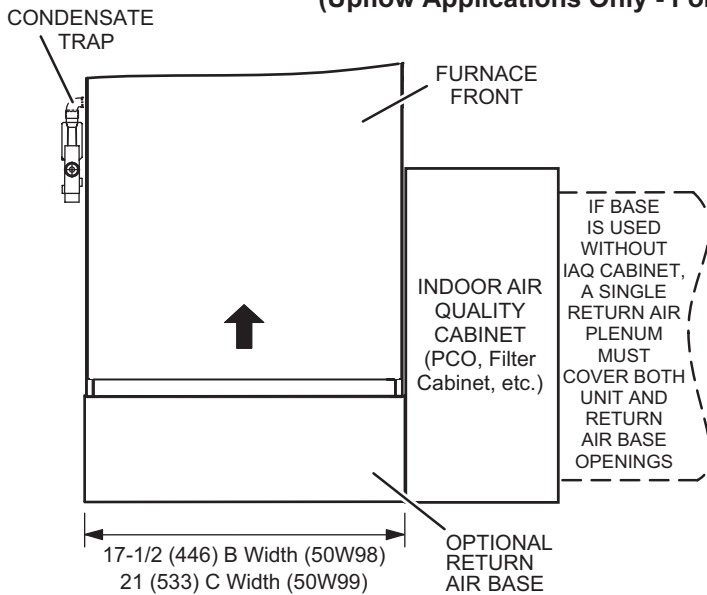

**NOTE-** Optional Side Return Air Filter Kits are not for use with Optional Return Air Base.

- <sup>1</sup> Both the unit return air opening and the base return air opening must be covered by a single plenum or IAQ cabinet. Minimum unit side return air opening dimensions for units requiring 1800 cfm or more of air (W x H): 23 x 11 in. (584 x 279 mm). The opening can be cut as needed to accommodate plenum or IAQ cabinet while maintaining dimensions shown. Side return air openings must be cut in the field. There are cutting guides stenciled on the cabinet for the side return air opening. The size of the opening must not extend beyond the markings on the furnace cabinet.
- <sup>2</sup> To minimize pressure drop, the largest opening height possible, up to 14 in. (356 mm), is preferred.

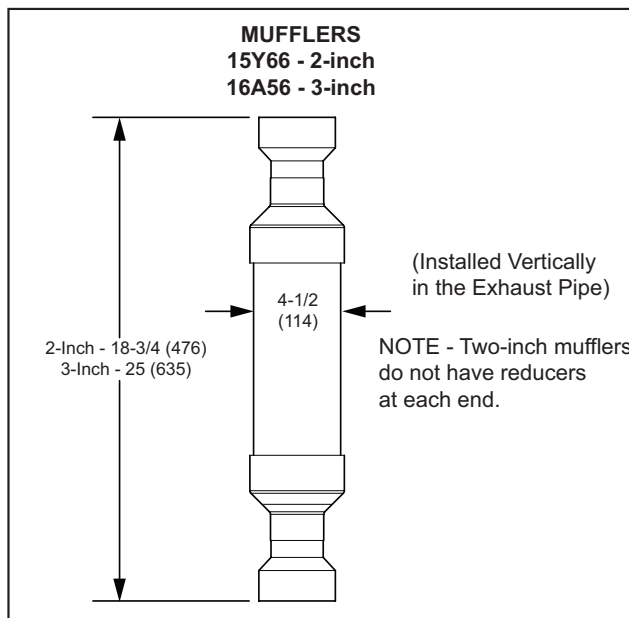
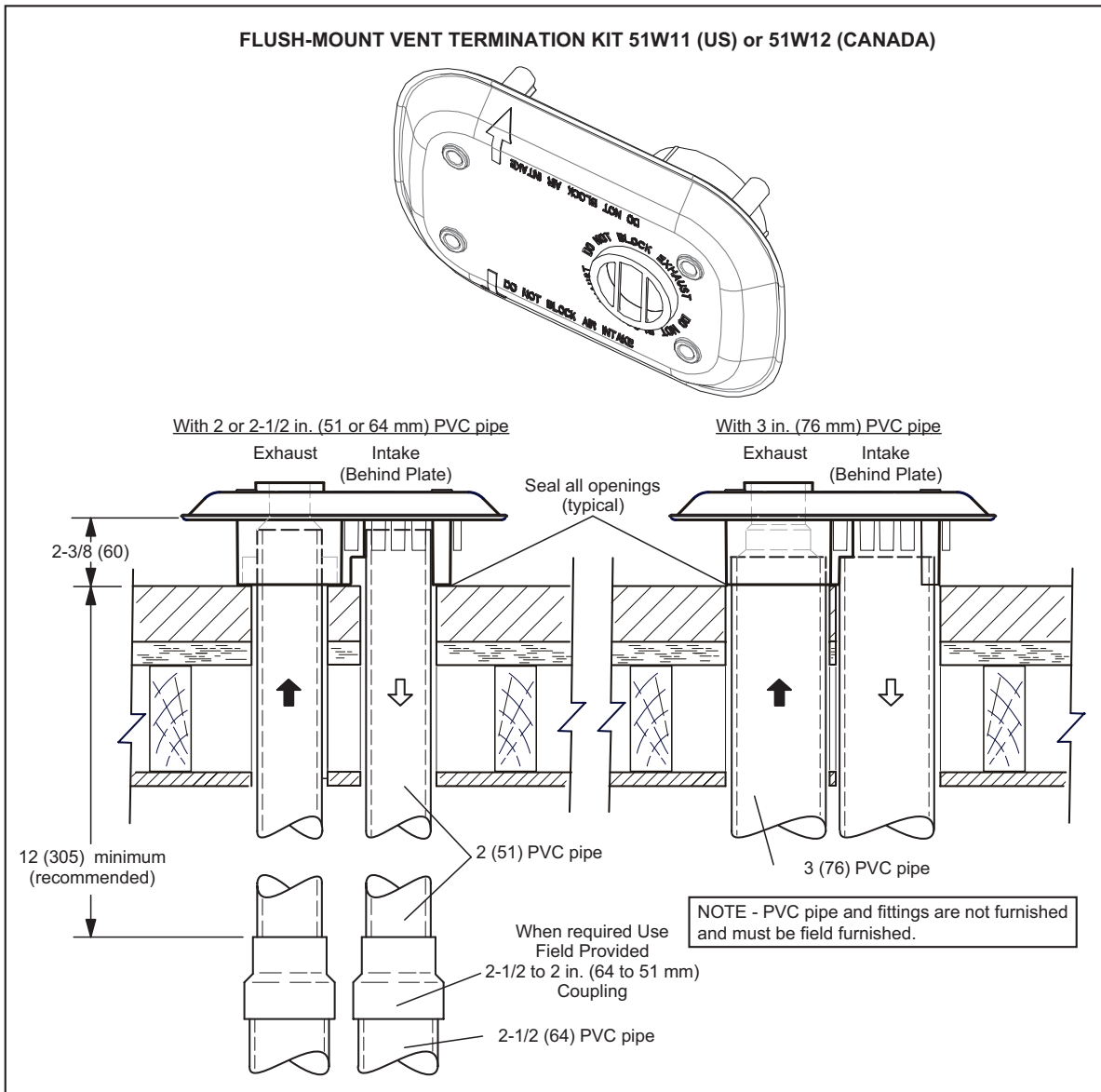

**CONCENTRIC WALL  
TERMINATION APPLICATIONS**

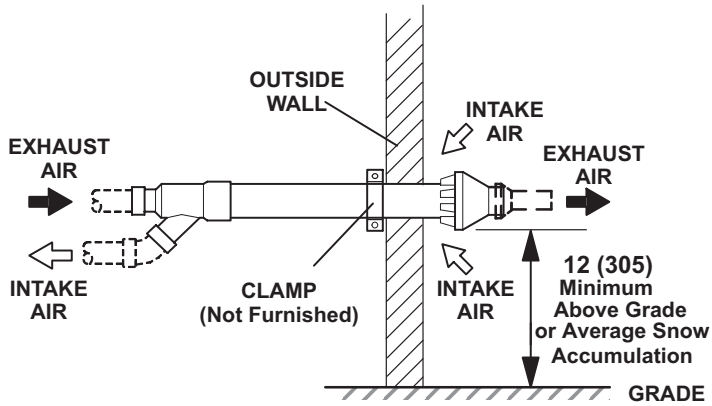

**CONCENTRIC ROOF  
TERMINATION APPLICATIONS**

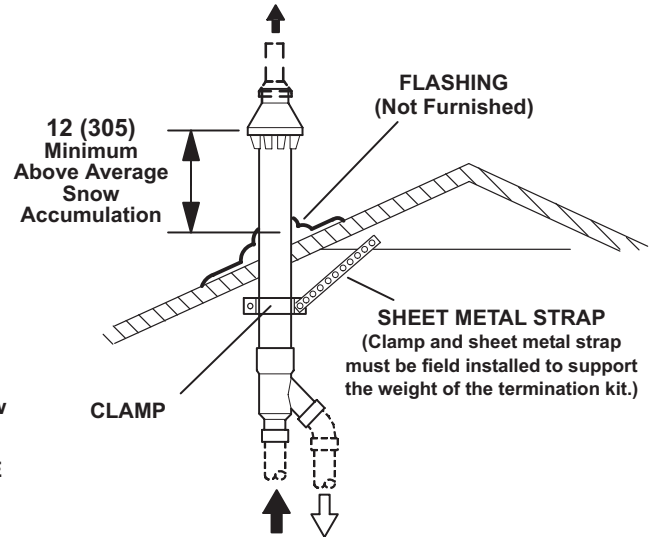

**71M80 / 69M29 / 44W92 – 2 inch kits**

**60L46 / 44W93 – 3 inch kits**

**See Installation Instructions for additional information.**

Note - Field provided reducer may be required to adapt different vent pipe sizes to termination.

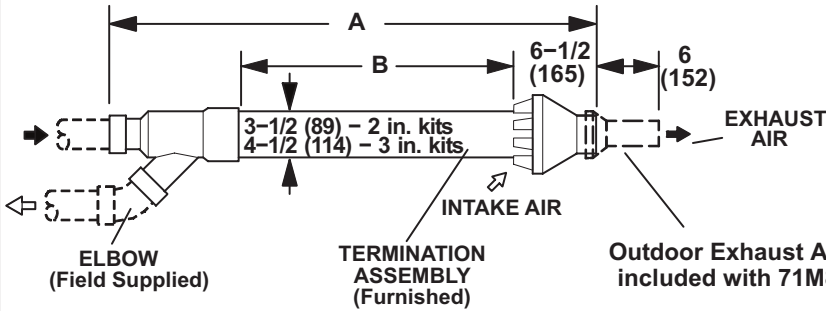

Cat. No.	A		B	
	in.	mm	in.	mm
71M80 69M29	33-3/8	848	16-3/4	425
44W92 (Canada)	29	737	15-1/2	394
60L46	38-7/8	987	21-3/16	538
44W93 (Canada)	36-1/8	918	19-1/2	495

**NOTE - Typical illustration for dimensions only. Design may vary depending on kit ordered.**

**WALL TERMINATION KITS (CLOSE-COUPLE)  
EXTENDED VENT FOR GRADE CLEARANCE  
2 inch (51 mm) 22G44 (US)  
3 inch (76 mm) 44J40 (US)**

**See Installation Instructions for additional information.**

Note - Field provided reducer may be required to adapt different vent pipe sizes to termination.

If Intake and Exhaust Pipe is less than 12 in. (305 mm) above snow accumulation or other obstructions, field fabricated piping must be installed.

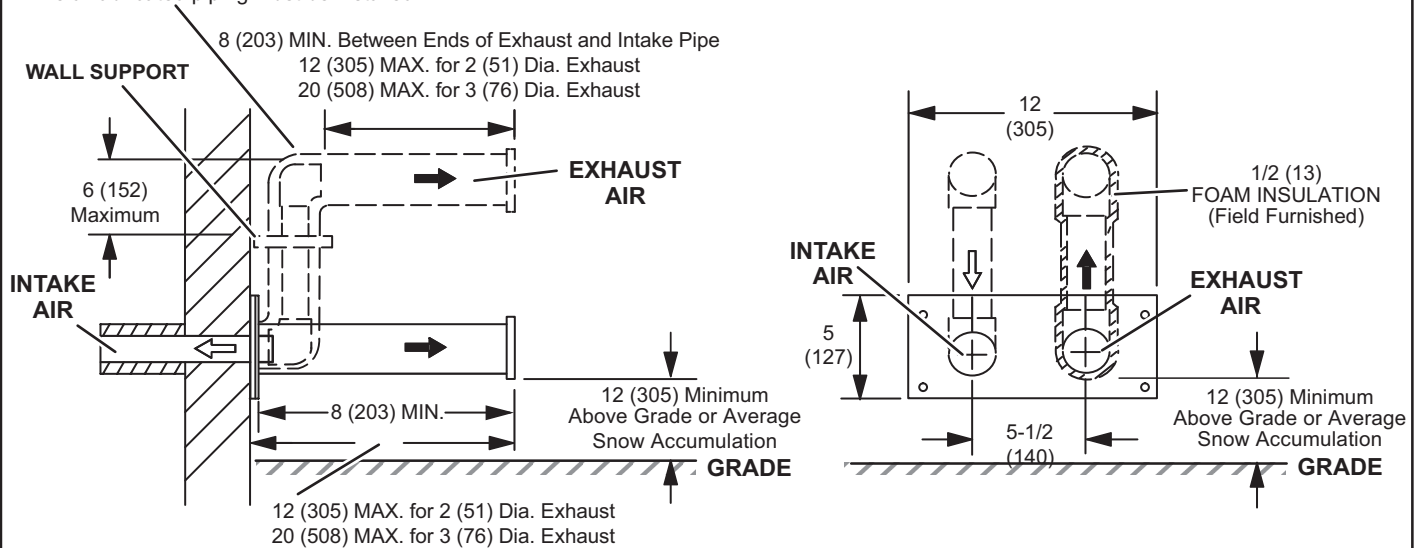

**WALL TERMINATION KITS (CLOSE-COUPLE)  
EXTENDED VENT FOR GRADE CLEARANCE  
2 inch (51 mm) 30G28 (WTK Canada)  
3 inch (76 mm) 81J20 (WTK Canada)**

**See Installation Instructions for additional information.**

Note - Field provided reducer may be required to adapt different vent pipe sizes to termination.

If Intake and Exhaust Pipe is less than 12 in. (305 mm) above snow accumulation or other obstructions, field fabricated piping must be installed.

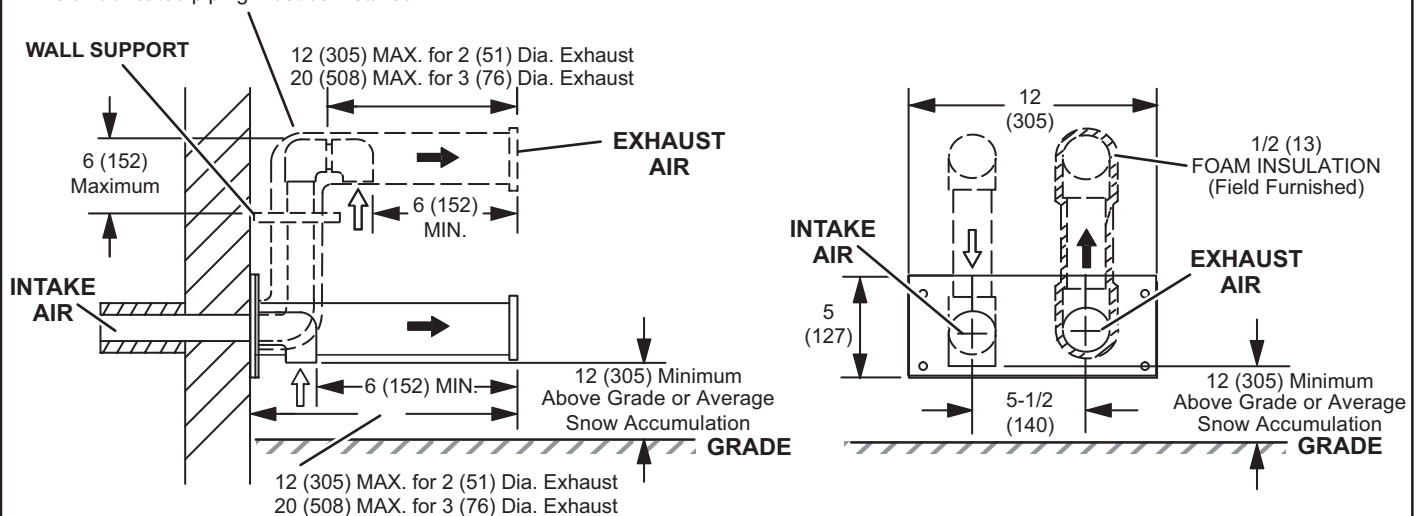

**UPFLOW POSITION**

Model No	C35/CX35 Cased				C35 Uncased			
	A		B		A		B	
C35/CX35	in.	mm	in.	mm	in.	mm	in.	mm
C35/CX35-18/24A C35/CX35-18/24B	16-1/2	419	49-1/2	1257	14-1/8	359	47-1/8	1197
C35/CX35-24A C35/CX35-24B	18-1/2	470	51-1/2	1308	16-3/8	416	49-3/8	1254
C35/CX35-30A C35/CX35-30B	22-1/2	572	55-1/2	1410	20-3/4	527	53-3/4	1365
C35/CX35-30/36A C35/CX35-30/36B C35/CX35-30/36C	24-1/2	622	57-1/2	1461	22-1/4	565	55-1/4	1403
C35/CX35-36A C35/CX35-36B	24-1/2	622	57-1/2	1461	22-3/8	568	55-3/8	1407
C35/CX35-48B C35/CX35-48C	27-1/2	699	60-1/2	1537	26-1/4	667	59-1/4	1505
C35/CX35-49C	29-1/2	749	62-1/2	1588	28-1/2	724	61-1/2	1562
C35/CX35-50/60C	27-1/2	699	60-1/2	1537	25-7/8	657	58-7/8	1495
CX35-60C	31-1/2	800	64-1/2	1638	30-5/8	778	63-5/8	1616

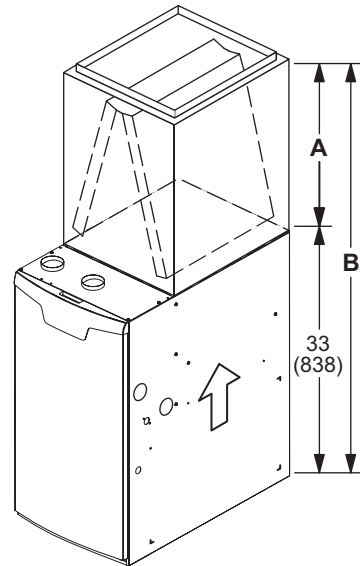

**HORIZONTAL POSITION**

Model No.	A		B		
	in.	mm	in.	mm	
<b>CH35</b>					
CH35-18A, CH35-24A, CH35-24B, CH35-30B,	CH35-36A, CH35-36B, CH35-36C, CH35-42C, CH35-48C	26-1/2	673	59-1/2	1511
CH35-30A, CH35-42B, CH35-48B,	CH35-51C	31-1/2	880	64-1/2	1638
<b>CHX35</b>					
CHX35-18A, CHX35-24A, CHX35-24B, CHX35-30B,	CHX35-36A, CHX35-36B, CHX35-36C, CHX35-42C, CHX35-48C	26-1/2	673	59-1/2	1511
CHX35-30A, CHX35-42B, CHX35-48B,	CHX35-51/61C	31-1/2	880	64-1/2	1638

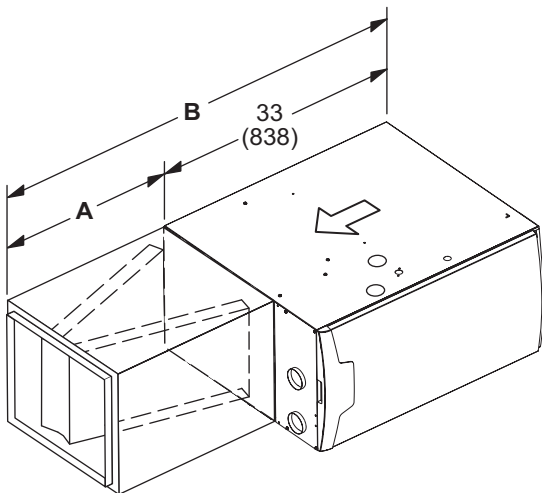



## BLOWER DATA

### ML193UH030XE36B PERFORMANCE (Less Filter)

External Static Pressure in. w.g.	Air Volume / Watts at Various Blower Speeds									
	High (Black)		Medium-High (Brown)		Medium (Blue)		Medium-Low (Yellow)		Low (Red)	
	cfm	Watts	cfm	Watts	cfm	Watts	cfm	Watts	cfm	Watts
0.00	1435	346	1170	191	1000	127	775	62	705	45
0.10	1400	351	1130	199	955	132	735	71	635	48
0.20	1360	358	1085	207	905	137	680	81	515	50
0.30	1325	370	1055	217	865	148	625	84	445	55
0.40	1300	382	1020	227	815	157	570	91	380	61
0.50	1265	387	990	231	785	161	515	95	310	66
0.60	1235	402	945	244	735	168	475	104	265	68
0.70	1200	411	910	253	710	175	425	107	215	72
0.80	1160	420	885	260	660	183	355	114	175	75

### ML193UH045XE36B PERFORMANCE (Less Filter)

External Static Pressure in. w.g.	Air Volume / Watts at Various Blower Speeds									
	High (Black)		Medium-High (Brown)		Medium (Blue)		Medium-Low (Yellow)		Low (Red)	
	cfm	Watts	cfm	Watts	cfm	Watts	cfm	Watts	cfm	Watts
0.00	1420	343	1305	264	1170	191	930	102	780	66
0.10	1390	348	1270	271	1135	199	885	109	735	71
0.20	1355	349	1230	280	1100	207	850	119	680	81
0.30	1330	368	1205	291	1060	220	795	126	625	84
0.40	1295	378	1180	298	1025	226	755	134	570	91
0.50	1265	386	1140	310	995	233	720	140	515	95
0.60	1240	402	1100	316	955	242	670	148	475	104
0.70	1210	411	1065	331	920	253	615	157	425	107
0.80	1160	420	1030	340	880	262	580	160	355	114

### ML193UH070XE36B PERFORMANCE (Less Filter)

External Static Pressure in. w.g.	Air Volume / Watts at Various Blower Speeds									
	High (Black)		Medium-High (Brown)		Medium (Blue)		Medium-Low (Yellow)		Low (Red)	
	cfm	Watts	cfm	Watts	cfm	Watts	cfm	Watts	cfm	Watts
0.00	1430	330	1300	249	1170	185	955	101	750	67
0.10	1395	337	1270	256	1145	192	910	107	705	71
0.20	1365	344	1245	269	1100	199	865	115	655	76
0.30	1340	357	1215	275	1080	210	815	123	600	82
0.40	1305	367	1180	285	1040	219	760	133	550	93
0.50	1270	377	1145	296	1005	230	720	139	505	95
0.60	1250	393	1110	305	970	237	685	147	455	100
0.70	1210	401	1080	316	930	247	635	152	405	109
0.80	1185	412	1045	325	885	255	600	158	355	114

### ML193UH090XE36C PERFORMANCE (Less Filter)

External Static Pressure in. w.g.	Air Volume / Watts at Various Blower Speeds									
	High (Black)		Medium-High (Brown)		Medium (Blue)		Medium-Low (Yellow)		Low (Red)	
	cfm	Watts	cfm	Watts	cfm	Watts	cfm	Watts	cfm	Watts
0.00	1410	280	1340	230	1160	160	835	90	770	64
0.10	1375	289	1315	239	1125	168	885	95	730	70
0.20	1340	301	1285	249	1090	175	840	104	685	74
0.30	1310	314	1260	261	1055	180	780	112	645	81
0.40	1275	326	1225	269	1015	195	730	117	590	87
0.50	1240	340	1190	279	965	201	675	126	535	91
0.60	1210	347	1160	288	920	211	620	133	495	98
0.70	1170	362	1130	299	885	221	580	138	455	102
0.80	1135	368	1105	304	855	229	535	144	405	107

## BLOWER DATA

### ML193UH090XE48C PERFORMANCE (Less Filter)

External Static Pressure in. w.g.	Air Volume / Watts at Various Blower Speeds									
	High (Black)		Medium-High (Brown)		Medium (Blue)		Medium-Low (Yellow)		Low (Red)	
	cfm	Watts	cfm	Watts	cfm	Watts	cfm	Watts	cfm	Watts
0.00	1710	373	1500	256	1395	200	1315	164	1205	129
0.10	1675	381	1475	263	1365	206	1275	173	1160	135
0.20	1655	392	1460	273	1315	219	1230	185	1110	142
0.30	1615	408	1410	282	1290	225	1195	192	1065	151
0.40	1595	416	1365	295	1245	236	1155	203	1010	160
0.50	1560	429	1335	308	1200	246	1105	214	965	167
0.60	1525	439	1295	315	1160	255	1060	221	915	176
0.70	1490	453	1260	325	1105	268	1015	229	875	184
0.80	1445	464	1230	332	1085	275	980	240	830	195

### ML193UH110XE48C PERFORMANCE (Less Filter)

External Static Pressure in. w.g.	Air Volume / Watts at Various Blower Speeds									
	High (Black)		Medium-High (Brown)		Medium (Blue)		Medium-Low (Yellow)		Low (Red)	
	cfm	Watts	cfm	Watts	cfm	Watts	cfm	Watts	cfm	Watts
0.00	1750	372	1535	254	1410	200	1330	169	1220	128
0.10	1715	380	1495	262	1380	208	1295	176	1175	135
0.20	1680	391	1470	272	1355	220	1255	184	1135	145
0.30	1640	405	1425	284	1300	230	1220	194	1085	154
0.40	1615	418	1395	296	1260	239	1170	206	1025	162
0.50	1580	433	1345	305	1225	249	1130	212	975	170
0.60	1540	445	1315	315	1180	258	1080	223	935	179
0.70	1515	450	1285	325	1135	268	1035	230	895	186
0.80	1470	467	1230	334	1095	278	995	240	850	192

### ML193UH110XE60C PERFORMANCE (Less Filter)

External Static Pressure in. w.g.	Air Volume / Watts at Different Blower Speeds																			
	Bottom Return Air, Side Return Air with Return Air from Both Sides or Return Air from Bottom and One Side.										Single Side Return Air – Air volumes in <b>bold</b> (over 1800 cfm) require Optional Return Air Base <u>and</u> field fabricated transition to accommodate 20 x 25 x 1 in. air filter in order to maintain proper air velocity.									
	High (Black)		Medium-High (Brown)		Medium (Blue)		Medium-Low (Yellow)		Low (Red)		High (Black)		Medium-High (Brown)		Medium (Blue)		Medium-Low (Yellow)		Low (Red)	
	cfm	Watts	cfm	Watts	cfm	Watts	cfm	Watts	cfm	Watts	cfm	Watts	cfm	Watts	cfm	Watts	cfm	Watts	cfm	Watts
0.00	2150	624	1915	436	1755	345	1650	280	1480	201	<b>2175</b>	<b>607</b>	<b>1930</b>	<b>412</b>	1760	330	1645	271	1475	199
0.10	2120	633	1880	441	1715	353	1605	288	1435	210	<b>2135</b>	<b>614</b>	<b>1885</b>	<b>421</b>	1705	342	1595	280	1415	207
0.20	2085	648	1830	455	1665	362	1560	298	1360	220	<b>2085</b>	<b>628</b>	<b>1830</b>	<b>437</b>	1670	351	1545	293	1370	218
0.30	2040	663	1795	468	1630	374	1515	317	1325	229	<b>2035</b>	<b>647</b>	1790	451	1625	364	1500	308	1315	227
0.40	2005	675	1760	482	1585	386	1470	327	1270	244	<b>1995</b>	<b>657</b>	1755	469	1590	378	1460	319	1275	240
0.50	1965	688	1710	496	1540	399	1425	336	1230	251	<b>1985</b>	<b>674</b>	1725	478	1545	391	1410	329	1225	250
0.60	1935	705	1680	507	1510	408	1390	347	1180	263	<b>1925</b>	<b>687</b>	1675	494	1495	401	1375	343	1170	257
0.70	1885	715	1635	521	1485	425	1345	359	1140	271	<b>1900</b>	<b>698</b>	1635	506	1450	413	1330	351	1125	270
0.80	1855	735	1600	534	1440	426	1305	367	1085	279	<b>1850</b>	<b>711</b>	1605	520	1415	430	1285	363	1075	281



## REVISIONS

Sections	Description of Change
Optional Accessories	Removed Wall Ring Kit (discontinued).



Visit us at [www.lennox.com](http://www.lennox.com)

For the latest technical information, [www.LennoxPros.com](http://www.LennoxPros.com)

Contact us at 1-800-4-LENNOX

NOTE - Due to Lennox' ongoing commitment to quality, Specifications, Ratings and Dimensions subject to change without notice and without incurring liability. Improper installation, adjustment, alteration, service or maintenance can cause property damage or personal injury. Installation and service must be performed by a qualified installer and servicing agency.

©2021 Lennox Industries, Inc.