



**PRODUCT SPECIFICATIONS**

Bulletin No. 210522  
November 2017  
Supersedes December 2015



**072-090-120-150 Models**

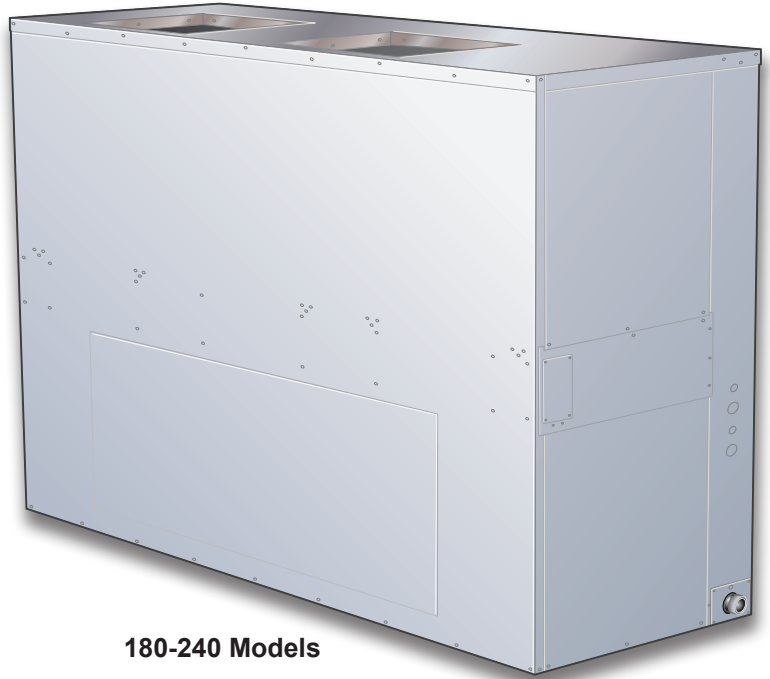

**180-240 Models**

**Nominal Capacity - 6 to 20 Tons  
Optional Electric Heat - 10 to 50 kW**

**MODEL NUMBER IDENTIFICATION**

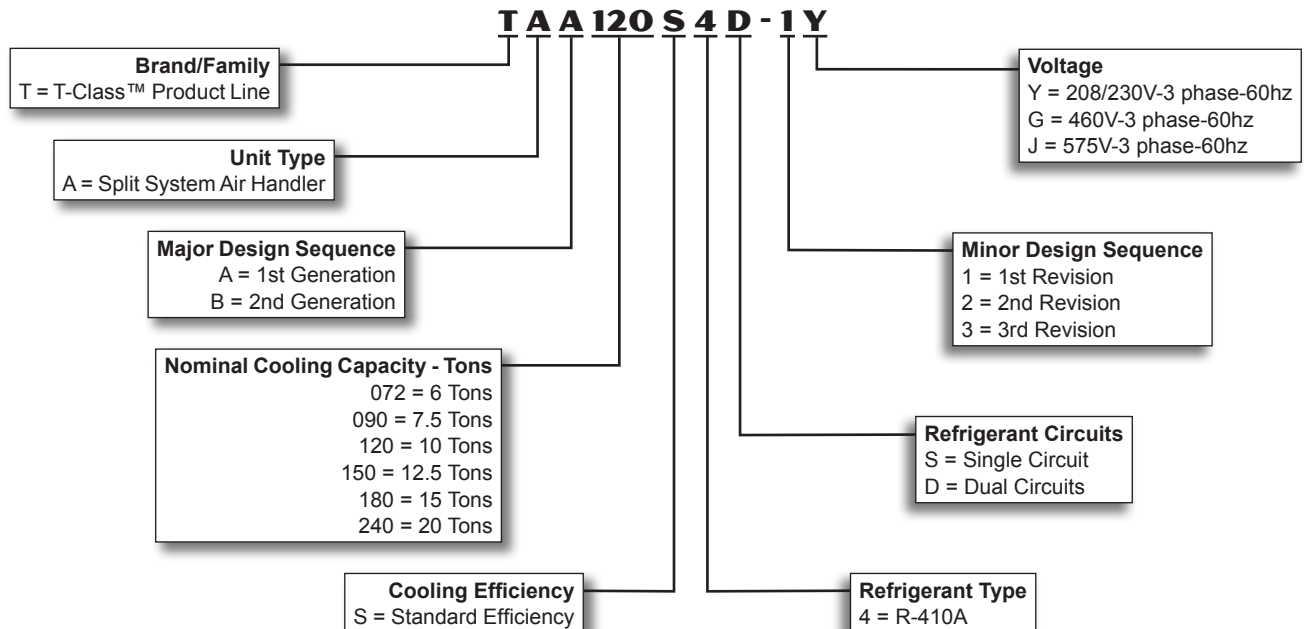

## FEATURES AND BENEFITS

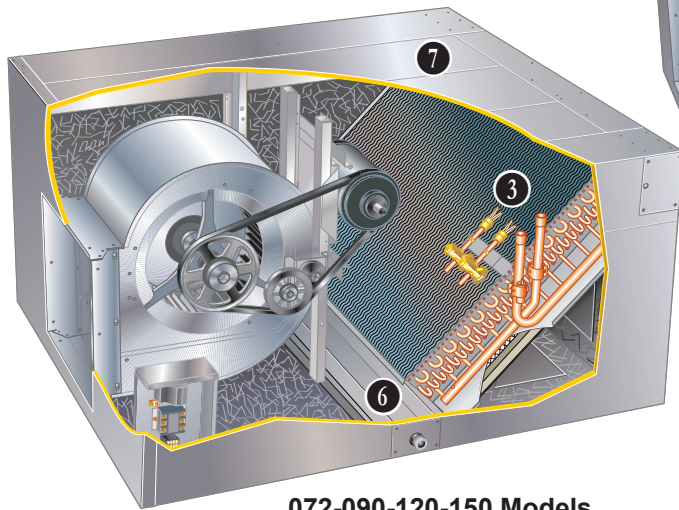

072-090-120-150 Models

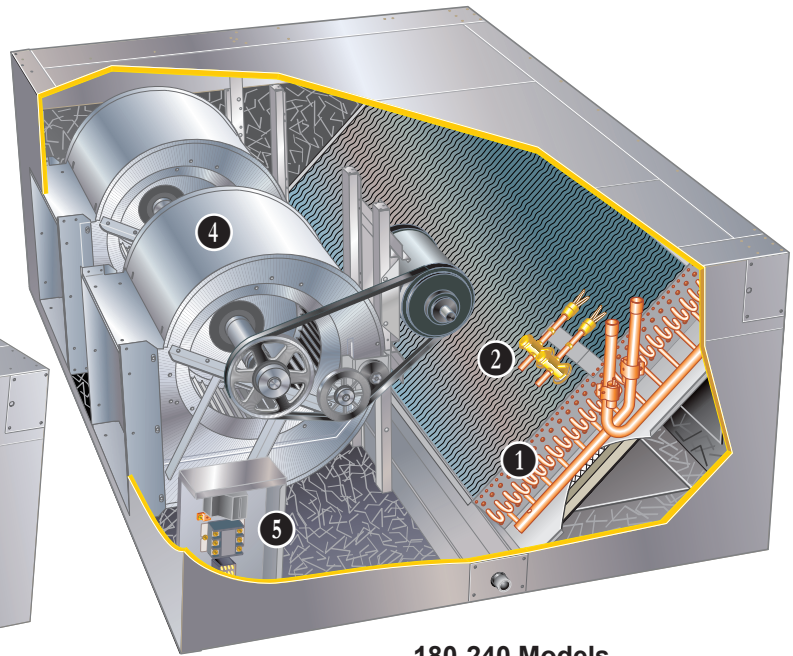

180-240 Models

### **CONTENTS**

Accessory Dimensions .....	35
Blower Data .....	10
Dimensions .....	31
Features And Benefits .....	2
Hot Water Coil Capacities.....	26
Model Number Identification .....	1
Options / Accessories .....	8
Optional Electric Heat Data .....	19
Specifications.....	8
Unit Clearances .....	7
Weight Data .....	30

### **WARRANTY**

All covered components have a limited warranty for one year.

Limited five years on high performance economizers.

Refer to Lennox Equipment Limited Warranty certificate for specific details.

### **APPROVALS**

Tested with matching air conditioner and heat pump units in the Lennox Research Laboratory environmental test room in accordance with AHRI Standard 340/360-2007.

Blower data is from unit tests conducted in the Lennox Laboratory air test chamber.

Units and components within are bonded for grounding to meet safety standards for servicing required by CSA, NEC and CEC.

All units are ETL listed.

Units manufactured in accordance with ISO 9001 quality standards.

### **APPLICATIONS**

Provides installation versatility and maximum efficiency in cooling performance, air handling and filtering in cooling or heat pump applications.

Convertible upflow or horizontal design.

Equipped with single circuit (072) or dual-circuit (090-240) indoor coils, suitable for application with Lennox 6 to 20 ton TSA air conditioners or 7.5 to 10 ton TPA heat pump outdoor units.

Each refrigerant circuit has a dedicated expansion valve.

090-240 models have a dual distribution system for two stage capacity control during cooling cycles.

Air handlers are shipped factory assembled ready to install. Standard static blower drive is furnished factory installed. Low or high static drive options are available as factory installed options. See Blower Drive Specifications Table for selections.

See air conditioners bulletins in Air Conditioners section for cooling capacities and ratings.

See heat pump bulletins in Heat Pump Outdoor Units section for cooling and heating capacities and ratings.

## FEATURES AND BENEFITS

### REFRIGERANT SYSTEM

#### 1 Multi-Circuit, Copper Tube Coil

Extra large surface area of Lennox designed coil provides maximum cooling efficiency, excellent heat transfer and low air resistance.

Coils on 090-240 models are face split with separate circuits, each circuit has its own expansion valve.

Precise circuiting gives uniform refrigerant distribution.

Lennox fabricated coil is constructed of precisely spaced ripple edged aluminum fins fitted to durable seamless, rifled copper tubes.

Rifled tubing provides enhanced heat transfer which results in maximum coil performance when combined with the Lennox fin design.

Fins are strengthened to resist bending and are equipped with collars that grip tubing for maximum contact area.

Flared tubing connections and silver soldering provide tight, leakproof joints.

Long life copper tubing is corrosion-resistant and easy to field service.

Coil is thoroughly factory tested under high pressure to ensure leakproof construction.

#### 2 Expansion Valve

For use with R-410A systems.

Factory installed and piped.

Multi-circuit coils are equipped with one thermal expansion valve per circuit.

Valves are sized for best performance.

090 and 120 models have internal check valves for use with heat pump systems.



#### 3 Refrigerant Piping and Drain Connections

Refrigerant line inlets (knockouts) are provided on both sides of the cabinet.

Refrigerant lines require sweat connections and are made internal to the cabinet.

Condensate drain outlet extends outside the cabinet for ease of connection. Condensate drain can be relocated to other side of cabinet and can be repositioned for horizontal air flow applications.

### Options/Accessories

#### Field Installed

##### Freezestat

Protects the evaporator coil from damaging ice build-up due to conditions such as low/no air flow, or low refrigerant charge.

##### Heat Pump Check Valve Kit (180-240 Models Only)

Field installed kit contains valve assemblies that field convert the coil to allow it to be matched with two smaller heat pump outdoor units.

### INDOOR AIR QUALITY

#### Filters

2 inch thick, throwaway fiberglass media filters are furnished as standard.

Filter rack design permits quick and easy removal of filters for servicing.

### Options/Accessories

#### Field Installed

##### Healthy Climate® High Efficiency Air Filters

Disposable MERV 11 or MERV 16 (Minimum Efficiency Reporting Value based on ASHRAE 52.2) efficiency 5 inch pleated filters.

5 inch pleated filters offer longer filter life and better filtration efficiency compared to standard 2 inch filters.

##### 5 Inch Filter Mounting Kits

Required for use with Health Climate MERV 11 or MERV 16 filters. Kit includes filter rack for 5 inch filters.

##### Healthy Climate® UVC Germicidal Light Kits

*Healthy Climate®* UVC light kits are specifically designed for the TA air handlers and attach directly to the indoor coil air shields without tools or fasteners at the optimal distance and location required. The UVC lights are sized to optimize the reduction of mold and other bioaerosols (bacteria and viruses) on the coil surface. In addition, the lights are equipped with unique (patent pending) directional honeycomb shields to focus the UVC light on the coil surface where it is needed and reduce the exposure of light on other components and access panels for improved safety and overall effectiveness.

Enhanced rapid start ballast provides UVC lamp operation at a full range of operating conditions.

LEDs on ballast show lamp operation status.

“Green” LED indicates power on”.

“Blue” LED indicates lamp operation.

Germicidal lamps emit ultra-violet (UVC) energy, which has been proven to be effective in reducing microbes such as viruses, bacteria, yeasts, and molds. This process either destroys the organism or controls its ability to reproduce.

Lamps operate on 208/230V/1ph power supply.

Step-down transformer is available for models used with 460V and 575V air handlers. Order separately.

Lamps may be operated from separate 208/230V/1ph power source.

All necessary hardware for installation is furnished.

Approved by ETL.

## FEATURES AND BENEFITS

### 4 BELT DRIVE BLOWERS

072-090-120-150 models are equipped with a single blower wheel, 180 and 240 models have dual blower wheels.

Centrifugal belt driven blowers deliver large air volumes quietly and with low power consumption.

Blower wheels are heavy-duty, with forward curved blades and double inlet.

Wheels are statically and dynamically balanced to eliminate vibration and designed to give maximum air delivery.

Bearings are heavy-duty, permanently sealed and lubricated.

Belt tension is automatically controlled by auto tensioning device.

Adjustable motor pulley allows speed adjustments.

Standard static drive is furnished factory installed. See Blower Drive Specifications table for optional factory installed low and high static drives available.

### Options/Accessories

#### Factory Installed

##### Low or High Static Drives

A choice of optional low or high static drives are available for factory installation. See Blower Drive Specifications table.

#### Field Installed

##### MSAV® (Multi-Stage Air Volume) Kit

Externally mounted enclosure houses a variable frequency drive (VFD) and a control that stages the supply air blower airflow. Designed for use on dual-stage split systems ranging from 7.5 to 20 ton capacity (TAA090 - TAA240), the VFD alters the frequency and voltage of the power supply to control blower motor speed and airflow. Split dual-stage systems equipped with this option comply with California Code of Regulations Title 24 and ASHRAE 90.1-2010 Section 6.4.3.10 requirements for staged indoor airflow.



The supply air blower has two speeds:

1. Low speed for part-load cooling operation.  
NOTE - Low speed is 66% of high speed.
2. High speed for full load cooling and all heat modes.

Full speed blower operation is set by adjusting the motor pulley to deliver the desired air volume.

The ventilation speed is selectable between high and low speed.

*NOTE - Part load airflow in cooling mode on MSAV® units should not be set below 220 cfm/nominal full load ton to reduce the risk of evaporator coil freeze-up.*

*NOTE - The VFD has an operational range of -40 to 125°F outdoor air ambient air temperature. Attic temperatures may exceed the 125°F operating range. If the air handler is installed in an attic the MSAV® kit must be mounted remotely away from the air handler in a location where the maximum operating temperature range is not exceeded.*

Lower operating costs are obtained when the blower is operated on lower speeds.

Mounting brackets are furnished for different mounting applications. See the Installation Instructions for details.

#### MSAV® Sequence of Operation

Ventilation speed is determined by the VENT SPEED switch setting on VFD control board (LO or HI).

Blower operates in low speed for mechanical cooling (Y1).

Blower operates in high speed for any other mode (free cooling, mechanical cooling Y1+Y2, and heating).

Economizer damper minimum position is fully closed in unoccupied mode.

In occupied mode, the economizer damper minimum position is determined by the setting of the two potentiometers on VFD control board.

- LO SPD MIN POS potentiometer sets the minimum position when blower is operating at low speed.
- HI SPD MIN POS potentiometer sets the minimum position when blower is operating at high speed.

### CONTROLS

#### 5 Control Box

Control box located in separate compartment in unit cabinet.

Box may be relocated to alternate location for easier access depending on application. See dimension drawings.

Low voltage terminal strip factory installed.

Blower contactor furnished and factory installed in control box.

All controls are pre-wired at the factory.

### OPTIONS

#### Field Installed

##### Commercial Control Systems L Connection® Network

Complete building automation control system for single or multi-zone applications.

Options include local interface, software for local or remote communication, and hardware for networking other control functions.

See L Connection Network Product Specifications Bulletin for details.

## OPTIONS / ACCESSORIES

### 6 CABINET

Cabinet is constructed of heavy-gauge, galvanized steel.

Cabinet is completely lined with thick fiberglass insulation resulting in quiet and efficient operation due to the excellent sound deadening and insulating qualities of fiberglass.

Supply and return air duct flanges are furnished for field installation. See dimension drawings.

Service access is provided on three sides (072-150) and four sides (180-240) of unit.

Large removable panels provide complete service access on one side of unit.

Electrical inlets are conveniently located in the cabinet. See dimension drawings

### 7 Drain Pan

Deep, corrosion resistant plastic drain pan.

Reversible drain pan allows for drain outlets on either end of cabinet and can be repositioned for horizontal air flow applications.

Drain pan is removable from either side in both horizontal and vertical applications.

## Options/Accessories

### Factory Installed

#### **Corrosion Protection**

Polymeric epoxy coating that is deposited by electrical transport (electrophoresis), using a process known as electrocoat (e-coat). Available for enhanced coil corrosion protection. Factory installed on the indoor coil. Blower housing is painted when this option is ordered.

### Field Installed

#### **Float Switch**

Prevents condensate overflow by turning the unit off when the condensate level is abnormally high.

#### **Return Air Grilles**

Anodized aluminum grille field installs in return air opening of air handler.

##### **Return Air Grille Free Area**

T2GARD30L-1 - 4.1 sq. ft.

T2GARD30M-1 - 5.9 sq. ft.

T2GARD30N-1 - 7.6 sq. ft.

### ELECTRIC HEAT SECTION

Furnished in a separate add-on matching cabinet.

Mounting hardware is furnished to secure cabinets together.

Pre-punched mounting holes are furnished for aligning electric heat section to air handler supply air flange.

Removable panel permits service access.

Electrical inlet provides wiring entry.

Field installed electric heaters are available in several kW sizes, see Electric Heat Data table.

Helix wound, nichrome heating elements are exposed directly in the air stream resulting in instant heat transfer, lower coil temperatures and long service life.

Elements are accurately located and insulated from the heavy-gauge steel support frame by high quality insulators.

Elements are equipped with individual limit controls providing positive protection in case of overheating.

Sub-fusing, contactors, control relays, 24V transformer are furnished.

Certain electric heat sizes may be two-stage controlled (with field provided control) with each stage being energized only when required. See Electric Heat Tables.

### HOT WATER COIL

Furnished in a separate add-on matching cabinet.

Mounting hardware is furnished to secure cabinets together.

Pre-punched mounting holes are furnished for aligning cabinet to air handler.

Cabinet is constructed of heavy-gauge galvanized steel.

Completely insulated with thick, foil-faced fiberglass insulation.

Removable panel permits service access.

Cabinet is reversible to allow piping on either side of unit.

Lennox designed and built coil has large face area, excellent heat transfer and low air resistance.

Constructed of precisely spaced ripple-edged aluminum fins fitted to durable copper tubes.

Fins are equipped with collars that grip tubing for maximum contact area.

Flared shoulder tubing connections and silver soldering provide tight, leakproof joints.

Long life copper tubing is easy to field service.

Coil is thoroughly factory tested under high pressure to ensure leakproof construction.

Valves and pumps must be furnished by installer.

## OPTIONS / ACCESSORIES

### ECONOMIZER OPTIONS

Factory assembled and wired economizer dampers and controls are available for field installation.

Heavy-gauge galvanized steel cabinet is completely insulated with thick, matte-faced fiberglass insulation.

Large removable panels on both sides of cabinet provide complete service access.

Mounting flanges provide ease of connection to air handler unit.

Flanges on outdoor air opening and return air opening permit easy duct connection.

Damper linkage and shafts are plated.

#### Factory or Field Installed

#### Standard Economizer Features (Not for Title 24)

Gear-driven action, return air and outdoor air dampers, plug-in connections to unit, neoprene seals, 24-volt, fully-modulating spring return motor, adjustable minimum damper position.

#### Standard Economizer Control Module

The Standard Economizer Control Module can be adjusted to operate based on outdoor air temperatures.



#### Economizer Controls:

- Damper Minimum Position - Can be set lower than traditional minimum air requirements resulting in cost savings.
- IAQ Sensor - Signals dampers to modulate and maintain 55°F when CO<sub>2</sub> is higher than the CO<sub>2</sub> setpoint.
- Demand Control Ventilation (DCV) LED - A steady green Demand Control Ventilation LED indicates the IAQ reading is higher than setpoint and requires more fresh air.
- Free Cool LED - A steady green LED indicates outdoor air is suitable for free cooling.

Free Cooling runs when outdoor air temperature is lower than the set temperature on the economizer control.

*NOTE: The Free Cooling default setting for outdoor air temperature sensor is 55°F.*

#### High Performance Economizer Features

Approved for California Title 24 building standards. ASHRAE 90.1-2010 compliant.

*Gear-driven action, high torque 24-volt fully-modulating spring return damper motor, return air and outdoor air dampers, plug-in connections to unit, nylon bearings, enhanced neoprene blade edge seals and flexible stainless steel jamb seals to minimize air leakage.*

*NOTE - High Performance Economizers are not approved for use with enthalpy controls in Title 24 applications.*

#### High Performance

#### Economizer Control Module

Module provides inputs and outputs to control economizer based on parameter settings.

Module automatically detects sensors by polling to determine which sensors are installed in system.

Module displays any alarm messages (fault detection and diagnostics) as an aid in troubleshooting.

Non-volatile memory retains parameter settings in case of power failure.

Keypad with four navigation buttons and LCD screen is furnished for setting economizer parameters.



- Menu Up/Exit (⬆) button returns to the main menu.
- Arrow Up (▲) button moves to the previous or next parameter within the selected menu.
- Arrow Down (▼) button moves to the next parameter within the selected menu.
- Select (enter) (↵) button confirms parameter selection.

#### Main Menu Structure:

- STATUS (economizer and system operation status)
- SETPOINTS (settings for various setpoint parameters)
- SYSTEM SETUP (settings/information about the system)
- ADVANCED SETUP (freeze protection, CO<sub>2</sub> settings, stage 3 delay and additional calibration settings)
- CHECKOUT (damper positions)
- ALARMS (output signal that can be configured for remote alarm monitoring)

*NOTE - The free cooling setpoint for Title 24 applications must be set based on the Climate Zone where the system is installed. See Section 140.4 "Prescriptive Requirements for Space Conditioning Systems" of the California Energy Commission's 2013 Building Energy Efficiency Standards.*

Refer to Installation Instructions for complete setup information and menu parameters available.

#### Field Installed

#### Differential Enthalpy Control (Not for Title 24)

Allows the outdoor air enthalpy control to select between outdoor air or return air, whichever has lower enthalpy. Field installed in economizer damper section.

## UNIT CLEARANCES - INCHES (MM)

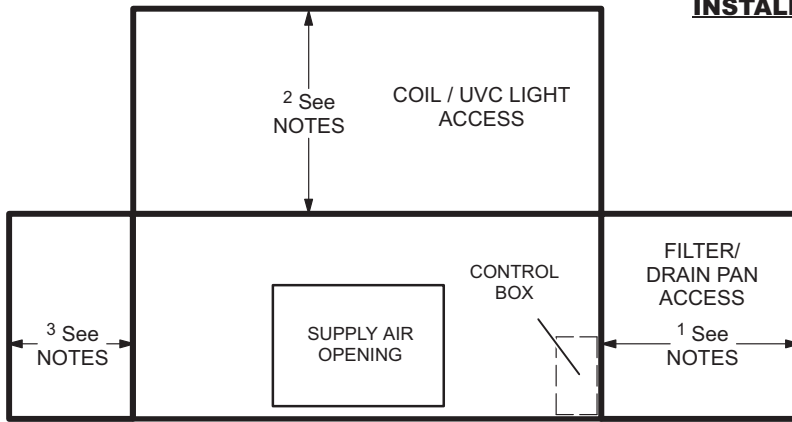

**TOP OR END VIEW**  
(Depending on Application)

### **INSTALLATION CLEARANCES (WITH ELECTRIC HEAT)**

**Cabinet** – 0 in. (0 mm)  
**To Plenum** – 0 in. (0 mm)  
**To Outlet Duct within 3 feet (914 mm)** – 0 in. (0 mm)

### **RECOMMENDED SERVICE CLEARANCES**

**<sup>1</sup> Filter Removal and Routine Maintenance:**  
 36 in. (914 mm)

**<sup>1</sup> Service Clearance for Drain Pan Removal:**  
 TAA072, TAA090 – 57 in. (1448 mm)  
 TAA120, TAA150 – 73 in. (1854 mm)  
 TAA180, TAA240 – 102 in. (2590 mm)

**<sup>2</sup> Coil Cleaning / UVC Light Access (Upflow):**  
 All models – 36 in. (914 mm)

**<sup>3</sup> Alternate Coil Cleaning / UVC Light Access:**  
 Provide 36 in. (914 mm) on this side if top/rear access is obstructed

**<sup>3</sup> Alternate Drain/Refrigerant Line Location:**  
 Allow additional clearance if refrigerant or drain lines are routed from this side of cabinet.

<b>SPECIFICATIONS</b>			
General Data	Model No.	TAA072S4S	TAA090S4D
	<b>Nominal Tonnage</b>	<b>6</b>	<b>7.5</b>
<b>Connections</b>	Liquid line o.d. - in. (sweat)	(1) 5/8	(2) 5/8
	Suction/Vapor line o.d. - in. (sweat)	(1) 1-1/8	(2) 7/8
	Condensate drain - in. (fpt)	1 (NPT)	1 (NPT)
<b>Refrigerant</b>	Not Furnished	R-410A	R-410A
<b>Evaporator Coil</b>	Net face area - sq. ft.	8.2	8.2
	Coil (Face) Split - 1st stage / 2nd stage (%)	---	50 / 50
	Tube diameter - in.	3/8	3/8
	Number of rows	3	4
	Fins per inch	17	17
<b>Blower and Drive</b>		See Blower Drive Specifications Table on page 16.	
	Wheel nominal diameter & width - in.	(1) 15 x 15	(1) 15 x 15
<b>Filter</b>	Number and size - in.	(3) 16 x 25 x 2	(3) 16 x 25 x 2

<b>SPECIFICATIONS</b>					
General Data	Model No.	TAA120S4D	TAA150S4D	TAA180S4D	TAA240S4D
	<b>Nominal Tonnage</b>	<b>10</b>	<b>12.5</b>	<b>15</b>	<b>20</b>
<b>Connections</b>	Liquid line o.d. - in. (sweat)	(2) 5/8	(2) 5/8	(2) 5/8	(2) 5/8
	Suction/Vapor line o.d. - in. (sweat)	(2) 7/8	(2) 7/8	(2) 1-1/8	(2) 1-1/8
	Condensate drain - in. (fpt)	1 (NPT)	1 (NPT)	1 (NPT)	1 (NPT)
<b>Refrigerant</b>	Not Furnished	R-410A	R-410A	R-410A	R-410A
<b>Evaporator Coil</b>	Net face area - sq. ft.	11.3	11.3	16.9	16.9
	Coil (Face) Split - 1st stage / 2nd stage (%)	50 / 50	50 / 50	50 / 50	50 / 50
	Tube diameter - in.	3/8	3/8	3/8	3/8
	Number of rows	4	4	3	4
	Fins per inch	17	17	17	17
<b>Blower and Drive</b>		See Blower Drive Specifications Table on page 16.			
	Wheel nominal diameter & width - in.	(1) 15 x 15	(1) 15 x 15	(2) 15 x 15	(2) 15 x 15
<b>Filter</b>	Number and size - in.	(4) 16 x 25 x 2	(4) 16 x 25 x 2	(6) 16 x 25 x 2	(6) 16 x 25 x 2

<b>OPTIONS / ACCESSORIES</b>								
Item	Catalog No.	072	090	120	150	180	240	
<b>BLOWER</b>								
<b>Blower Drives</b>		See Blower Drive Specifications Table on page 16.						
<b>MSAV® (MULTI-STAGE AIR VOLUME) SUPPLY AIR BLOWER VFD KIT</b>								
<b>2 HP</b>	208/240V-3ph - T2MSAV20LM1Y	<b>92W63</b>	X	X				
	460V-3ph - T2MSAV20LM1G	<b>92W64</b>	X	X				
	575V-3ph - T2MSAV20LM1J	<b>92W65</b>	X	X				
<b>3 HP</b>	208/240V-3ph - T2MSAV20LN1Y	<b>92W66</b>	X	X	X	X		
	460V-3ph - T2MSAV20LN1G	<b>92W67</b>	X	X	X	X		
	575V-3ph - T2MSAV20LN1J	<b>92W68</b>	X	X	X	X		
<b>5 HP</b>	208/240V-3ph - T2MSAV20MN1Y	<b>92W69</b>			X	X	X	
	460V-3ph - T2MSAV20MN1G	<b>92W70</b>			X	X	X	
	575V-3ph - T2MSAV20MN1J	<b>92W71</b>			X	X	X	
<b>7.5 HP</b>	208/240V-3ph - T2MSAV20N-1Y	<b>92W72</b>						X
	460V-3ph - T2MSAV20N-1G	<b>92W73</b>						X
	575V-3ph - T2MSAV20N-1J	<b>92W74</b>						X
<b>CABINET</b>								
<b>Corrosion Protection</b>	<b>Factory</b>	O	O	O	O	O	O	O
<b>Float Switch</b>	T2SNSR71LN1-	<b>91W69</b>	X	X	X	X	X	X
<b>Return Air Grille</b>	T2GARD30L-1	<b>47W49</b>	X	X				
	T2GARD30M-1	<b>47W50</b>			X	X		
	T2GARD30N-1	<b>47W51</b>					X	X
<b>CONTROLS</b>								
<b>L Connection® Network</b>	See separate bulletin	X	X	X	X	X	X	X

NOTE - The catalog and model numbers that appear here are for ordering field installed accessories only.

O - Factory Installed with extended lead time.

X - Field Installed.



## OPTIONS / ACCESSORIES

Item	Catalog No.	072	090	120	150	180	240
<b>ELECTRIC HEAT</b>							
10 kW	208/240V-3ph - T3EH0010LM1Y	46W50	X	X	X	X	
	460V-3ph - T3EH0010LM1G	46W55	X	X	X	X	
	575V-3ph - T3EH0010LM1J	46W60	X	X	X	X	
15 kW	208/240V- 3ph - T3EH0015LM1Y	46W51	X	x	X	X	
	460V-3ph - T3EH0015LM1G	46W56	X	X	X	X	
	575V-3ph - T3EH0015LM1J	46W61	X	X	X	X	
25 kW	208/240V-3ph - T3EH0025LM1Y	46W52	X	X	X	X	
	460V-3ph - T3EH0025LM1G	46W57	X	X	X	X	
	575V-3ph - T3EH0025LM1J	46W62	X	X	X	X	
35 kW	208/240V-3ph - T3EH0035LM1Y	46W53		X	X	X	
	460V-3ph - T3EH0035LM1G	46W58		X	X	X	
	575V-3ph - T3EH0035LM1J	46W63		X	X	X	
20 kW	208/240V-3ph - T3EH0020N-1Y	46W65				X	X
	460V-3ph - T3EH0020N-1G	46W69				X	X
	575V-3ph - T3EH0020N-1J	46W73				X	X
30 kW	208/240V-3ph - T3EH0030N-1Y	46W66				X	X
	460V-3ph - T3EH0030N-1G	46W70				X	X
	575V-3ph - T3EH0030N-1J	46W74				X	X
40 kW	208/240V-3ph - T3EH0040N-1Y	49W39				X	X
	460V-3ph - T3EH0040N-1G	49W40				X	X
	575V-3ph - T3EH0040N-1J	49W41				X	X
50 kW	208/240V-3ph - T3EH0050N-1Y	46W67				X	X
	460V-3ph - T3EH0050N-1G	46W71				X	X
	575V-3ph - T3EH0050N-1J	46W75				X	X
<b>ECONOMIZER</b>							
<b>Standard Economizers (Not for Title 24)</b>							
	T2ECON31L-1-	44W94	X	X			
	T2ECON31M-1-	44W95			X	X	
	T2ECON31N-1-	44W96				X	X
<b>High Performance Economizers (Approved for California Title 24 Building Standards)</b>							
	T2ECON34L-1	10U48	X	X			
	T2ECON34M-1	10U49			X	X	
	T2ECON34N-1	10U50				X	X
<b>Economizer Controls (Not for Title 24)</b>							
Single Enthalpy Control (Standard Economizer)	T1SNSR60AN1	17W71	X	X	X	X	X
Single Enthalpy Control (High Performance Economizer)	C1NSR61FF1	11G21	X	X	X	X	X
<b>NOTE - FOR DIFFERENTIAL ENTHALPY CONTROL ORDER TWO OF THE SAME CONTROLS ABOVE.</b>							
<b>HOT WATER COIL</b>							
	T2HWCL10LM1-	44W20	X	X	X	X	
	T2HWCL10N-1-	44W21				X	X
<b>INDOOR AIR QUALITY</b>							
<b>Air Filters</b>							
<sup>1</sup> Healthy Climate® High Efficiency Air Filters (16 x 25 x 5)	MERV 11 - HCF16-11	X6670	X	X	X	X	X
	MERV 16 - HCF16-16	X6672	X	X	X	X	X
5 Inch Filter Mounting Kits	T2FLTR70L-1-	47W71	X	X			
	T2FLTR70M-1-	47W72			X	X	
	T2FLTR70N-1-	47W73				X	X
Healthy Climate® UVC Light Kit (208/230V-1ph)	208/230V - T2UVCL10LM1	46W43	X	X	X	X	
	208/230V - T2UVCL10N-1	46W44				X	X
	<sup>2</sup> 460V/230V Step-Down Transformer	96M07	X	X	X	X	X
	<sup>2</sup> 575V/230V Step-Down Transformer	96M08	X	X	X	X	X
<b>REFRIGERANT SYSTEM</b>							
Freezestat	T2SNSR70N1-	91W70	X	X	X	X	X
Heat Pump Check Valve Kit	T2CVLV10N-1-	47W48				X	
	T2CVLV11N-1-	50W73					X

NOTE - The catalog and model numbers that appear here are for ordering field installed accessories only.

X - Field Installed.

<sup>1</sup> Order 5 in. Filter Mounting Kit and required number of MERV 11 or MERV 16 filters: - (3) 072-090, (4) 120-150, (6) 180-240.

<sup>2</sup> Step-down transformer (460V or 575V to 208/230V-1ph) or separate power supply is required.

## BLOWER DATA

### TAA072 BLOWER PERFORMANCE

All data is measured external to the unit with dry coil and standard 2 in. air filters in place.

FOR ALL UNITS ADD:

1 - Wet indoor coil air resistance of selected unit.

2 - Any field installed accessories air resistance (electric heat, economizer, etc.) See page 17.

Then determine from table the blower motor hp and drive rpm required. See page 16 for blower drive specifications.

Air Volume cfm	STATIC PRESSURE EXTERNAL TO UNIT - Inches Water Gauge															
	0.1		0.2		0.3		0.4		0.5		0.6		0.7		0.8	
	RPM	BHP	RPM	BHP	RPM	BHP	RPM	BHP	RPM	BHP	RPM	BHP	RPM	BHP	RPM	BHP
1900	428	0.57	479	0.66	531	0.74	581	0.81	629	0.88	675	0.94	718	1.01	758	1.07
2000	434	0.59	486	0.69	538	0.77	589	0.84	637	0.91	682	0.98	725	1.05	765	1.11
2100	441	0.62	493	0.72	545	0.8	596	0.88	644	0.95	689	1.02	732	1.09	771	1.15
2200	448	0.65	501	0.75	553	0.83	604	0.91	652	0.98	696	1.06	738	1.13	778	1.2
2300	456	0.68	508	0.78	561	0.86	612	0.94	659	1.02	704	1.1	746	1.17	785	1.24
2400	463	0.71	516	0.81	569	0.9	620	0.98	667	1.06	711	1.14	753	1.22	792	1.29
2500	470	0.74	524	0.84	578	0.94	629	1.02	675	1.1	719	1.19	760	1.27	798	1.34
2600	478	0.77	533	0.88	587	0.98	637	1.06	683	1.15	726	1.24	767	1.32	805	1.39
2700	486	0.81	542	0.92	596	1.02	646	1.11	692	1.2	734	1.29	775	1.37	812	1.45
2800	495	0.85	552	0.96	606	1.07	655	1.16	700	1.25	742	1.34	782	1.42	819	1.5
2900	504	0.89	561	1.01	616	1.11	665	1.2	708	1.3	750	1.39	789	1.48	826	1.56
3000	514	0.93	572	1.05	626	1.16	674	1.26	717	1.35	758	1.45	797	1.54	833	1.62

Air Volume cfm	STATIC PRESSURE EXTERNAL TO UNIT - Inches Water Gauge															
	0.9		1		1.1		1.2		1.3		1.4		1.5			
	RPM	BHP	RPM	BHP	RPM	BHP	RPM	BHP	RPM	BHP	RPM	BHP	RPM	BHP		
1900	796	1.13	830	1.19	862	1.25	893	1.32	922	1.39	950	1.46	978	1.54		
2000	802	1.17	836	1.23	868	1.3	898	1.37	928	1.44	956	1.52	983	1.6		
2100	808	1.22	842	1.28	874	1.35	904	1.42	933	1.5	961	1.58	988	1.66		
2200	814	1.26	848	1.33	879	1.4	909	1.48	938	1.56	966	1.64	993	1.73		
2300	820	1.31	854	1.38	885	1.46	915	1.53	943	1.62	971	1.7	998	1.79		
2400	827	1.36	860	1.43	891	1.51	920	1.59	949	1.68	976	1.77	1003	1.86		
2500	833	1.41	866	1.49	897	1.57	926	1.66	954	1.75	981	1.84	1008	1.93		
2600	840	1.47	872	1.55	902	1.63	932	1.72	960	1.81	987	1.91	1013	2.01		
2700	846	1.53	878	1.61	908	1.7	937	1.79	965	1.88	992	1.98	1018	2.08		
2800	853	1.58	884	1.67	914	1.76	943	1.86	970	1.96	997	2.06	1023	2.16		
2900	859	1.65	890	1.74	920	1.83	948	1.93	975	2.03	1002	2.14	1028	2.24		
3000	866	1.71	896	1.8	926	1.9	954	2	981	2.11	1007	2.22	1032	2.33		

## BLOWER DATA

### TAA090 BLOWER PERFORMANCE

All data is measured external to the unit with dry coil and standard 2 in. air filters in place.

FOR ALL UNITS ADD:

1 - Wet indoor coil air resistance of selected unit.

2 - Any field installed accessories air resistance (electric heat, economizer, etc.) See page 17.

Then determine from table the blower motor hp and drive rpm required. See page 16 for blower drive specifications.

Air Volume cfm	STATIC PRESSURE EXTERNAL TO UNIT - Inches Water Gauge															
	0.1		0.2		0.3		0.4		0.5		0.6		0.7		0.8	
	RPM	BHP	RPM	BHP	RPM	BHP	RPM	BHP	RPM	BHP	RPM	BHP	RPM	BHP	RPM	BHP
1600	430	0.52	485	0.62	539	0.71	590	0.77	636	0.83	680	0.88	721	0.94	758	0.99
1700	439	0.55	494	0.65	548	0.74	599	0.80	645	0.86	688	0.91	729	0.97	766	1.03
1800	448	0.58	503	0.68	558	0.77	608	0.83	654	0.89	697	0.95	737	1.01	774	1.08
1900	457	0.62	513	0.72	567	0.80	617	0.86	663	0.93	705	0.99	745	1.06	781	1.12
2000	467	0.65	523	0.75	577	0.83	627	0.90	672	0.96	714	1.03	753	1.10	789	1.17
2100	477	0.68	533	0.78	587	0.86	637	0.93	681	1.00	723	1.08	762	1.15	797	1.22
2200	487	0.72	543	0.82	597	0.90	646	0.97	691	1.05	732	1.12	770	1.20	805	1.27
2300	497	0.75	554	0.85	608	0.94	657	1.01	700	1.09	741	1.17	779	1.25	813	1.32
2400	508	0.79	565	0.89	619	0.98	667	1.06	710	1.14	750	1.23	787	1.30	822	1.38
2500	519	0.83	577	0.94	630	1.02	677	1.10	720	1.19	759	1.28	796	1.36	830	1.43
2600	531	0.87	588	0.98	641	1.07	688	1.16	729	1.25	769	1.34	805	1.42	839	1.49
2700	543	0.92	600	1.03	653	1.12	698	1.21	739	1.31	778	1.40	814	1.48	848	1.55
2800	555	0.97	613	1.08	664	1.17	709	1.27	749	1.37	788	1.46	824	1.54	857	1.62
2900	568	1.02	625	1.13	676	1.22	719	1.32	759	1.43	797	1.52	833	1.60	866	1.68
3000	581	1.07	638	1.18	687	1.28	730	1.39	769	1.49	807	1.58	842	1.67	875	1.75
3100	595	1.12	651	1.24	699	1.34	740	1.45	779	1.56	817	1.65	852	1.73	883	1.82
3200	609	1.18	664	1.30	710	1.41	751	1.52	789	1.63	827	1.72	861	1.80	892	1.89
3300	624	1.24	677	1.36	722	1.48	761	1.59	799	1.70	836	1.79	870	1.88	901	1.97
3400	639	1.30	690	1.43	733	1.55	772	1.67	810	1.77	846	1.86	879	1.95	909	2.05
3500	653	1.37	703	1.50	745	1.62	782	1.75	820	1.85	856	1.94	888	2.03	917	2.14
3600	668	1.44	715	1.57	756	1.70	793	1.83	830	1.93	865	2.02	897	2.12	925	2.24

Air Volume cfm	STATIC PRESSURE EXTERNAL TO UNIT - Inches Water Gauge													
	0.9		1		1.1		1.2		1.3		1.4		1.5	
	RPM	BHP	RPM	BHP	RPM	BHP	RPM	BHP	RPM	BHP	RPM	BHP	RPM	BHP
1600	793	1.05	826	1.10	859	1.15	891	1.21	923	1.27	952	1.34	981	1.42
1700	800	1.09	833	1.15	866	1.20	899	1.26	930	1.33	959	1.40	987	1.48
1800	807	1.13	840	1.19	873	1.25	906	1.31	936	1.38	966	1.46	994	1.54
1900	815	1.18	848	1.24	881	1.30	913	1.36	943	1.44	972	1.52	1000	1.60
2000	823	1.23	856	1.29	889	1.35	921	1.42	951	1.50	979	1.58	1007	1.67
2100	830	1.28	863	1.34	896	1.40	928	1.48	958	1.56	986	1.65	1013	1.74
2200	838	1.33	871	1.39	904	1.46	935	1.54	965	1.63	993	1.72	1020	1.81
2300	846	1.39	880	1.45	912	1.52	943	1.61	972	1.70	999	1.79	1026	1.88
2400	855	1.44	888	1.51	920	1.59	950	1.67	979	1.77	1006	1.86	1033	1.96
2500	863	1.50	896	1.57	928	1.65	958	1.74	986	1.84	1013	1.94	1039	2.04
2600	872	1.56	904	1.64	936	1.72	965	1.82	993	1.92	1019	2.02	1045	2.12
2700	880	1.62	913	1.70	943	1.79	972	1.89	1000	2.00	1026	2.10	1052	2.20
2800	889	1.69	921	1.77	951	1.87	979	1.97	1006	2.08	1033	2.18	1058	2.29
2900	898	1.76	929	1.85	959	1.95	987	2.05	1013	2.16	1039	2.26	1064	2.37
3000	906	1.83	937	1.93	966	2.03	994	2.13	1020	2.24	1046	2.35	1070	2.46
3100	914	1.91	944	2.01	973	2.11	1001	2.22	1027	2.33	1052	2.44	1077	2.55
3200	922	1.99	952	2.09	980	2.20	1008	2.30	1033	2.41	1058	2.53	1083	2.64
3300	930	2.07	959	2.18	987	2.29	1014	2.39	1040	2.50	1065	2.62	1089	2.73
3400	938	2.16	966	2.27	994	2.38	1021	2.49	1046	2.60	1071	2.71	1095	2.83
3500	945	2.26	973	2.37	1001	2.48	1028	2.58	1053	2.69	1077	2.81	1101	2.93
3600	953	2.35	980	2.47	1008	2.58	1034	2.68	1059	2.79	1084	2.91	1107	3.03

## BLOWER DATA

### TAA120 BLOWER PERFORMANCE

All data is measured external to the unit with dry coil and standard 2 in. air filters in place.

FOR ALL UNITS ADD:

1 - Wet indoor coil air resistance of selected unit.

2 - Any field installed accessories air resistance (electric heat, economizer, etc.) See page 17.

Then determine from table the blower motor hp and drive rpm required. See page 16 for blower drive specifications.

Air Volume cfm	STATIC PRESSURE EXTERNAL TO UNIT - Inches Water Gauge															
	0.1		0.2		0.3		0.4		0.5		0.6		0.7		0.8	
	RPM	BHP	RPM	BHP	RPM	BHP	RPM	BHP	RPM	BHP	RPM	BHP	RPM	BHP	RPM	BHP
2200	441	0.11	483	0.27	524	0.42	565	0.55	605	0.65	643	0.74	678	0.80	713	0.85
2400	452	0.20	494	0.36	536	0.51	576	0.63	616	0.73	653	0.81	688	0.87	722	0.92
2600	463	0.30	505	0.45	547	0.60	588	0.72	627	0.82	664	0.89	699	0.95	731	1.00
2800	475	0.39	517	0.55	559	0.69	600	0.81	638	0.90	675	0.98	709	1.04	742	1.09
3000	487	0.49	529	0.65	571	0.79	612	0.91	650	1.00	687	1.07	721	1.13	752	1.19
3200	500	0.60	542	0.75	584	0.89	624	1.01	663	1.10	699	1.17	732	1.23	764	1.30
3400	513	0.71	555	0.86	597	1.00	638	1.11	676	1.20	711	1.28	745	1.35	775	1.42
3600	526	0.82	569	0.98	611	1.12	651	1.23	689	1.32	725	1.40	757	1.47	788	1.55
3800	540	0.93	583	1.10	626	1.24	666	1.36	704	1.45	739	1.53	771	1.61	801	1.69
4000	554	1.05	598	1.23	641	1.38	682	1.50	719	1.60	753	1.68	785	1.76	814	1.85
4200	569	1.18	614	1.37	658	1.53	698	1.65	735	1.75	768	1.84	799	1.92	828	2.02
4400	585	1.33	631	1.53	675	1.69	715	1.82	751	1.93	784	2.01	814	2.10	843	2.20
4600	603	1.50	650	1.71	694	1.88	733	2.01	769	2.11	800	2.20	829	2.29	858	2.40
4800	622	1.68	670	1.90	714	2.07	752	2.20	786	2.30	816	2.39	845	2.48	873	2.61
5000	643	1.89	691	2.11	734	2.28	771	2.40	804	2.50	833	2.59	860	2.69	888	2.82

Air Volume cfm	STATIC PRESSURE EXTERNAL TO UNIT - Inches Water Gauge													
	0.9		1		1.1		1.2		1.3		1.4		1.5	
	RPM	BHP	RPM	BHP	RPM	BHP	RPM	BHP	RPM	BHP	RPM	BHP	RPM	BHP
2200	746	0.89	780	0.95	814	1.01	847	1.07	880	1.14	912	1.21	941	1.29
2400	754	0.97	787	1.03	821	1.10	854	1.17	887	1.25	918	1.32	947	1.40
2600	763	1.06	796	1.12	829	1.20	862	1.28	895	1.36	926	1.45	955	1.53
2800	773	1.15	805	1.22	838	1.30	871	1.39	904	1.48	935	1.58	964	1.67
3000	783	1.26	815	1.34	848	1.43	881	1.52	914	1.62	944	1.72	973	1.82
3200	794	1.37	826	1.46	858	1.56	892	1.66	924	1.76	955	1.87	983	1.98
3400	806	1.50	837	1.60	870	1.70	903	1.81	935	1.92	965	2.04	994	2.15
3600	818	1.64	849	1.74	882	1.86	915	1.97	947	2.09	977	2.21	1004	2.33
3800	831	1.79	862	1.91	895	2.03	928	2.15	959	2.28	988	2.40	1015	2.52
4000	844	1.96	876	2.08	908	2.21	941	2.34	972	2.47	1000	2.60	1026	2.72
4200	858	2.14	890	2.27	922	2.40	954	2.54	984	2.68	1012	2.81	1037	2.94
4400	873	2.33	904	2.47	936	2.61	968	2.75	997	2.89	1024	3.03	1048	3.16
4600	887	2.53	919	2.68	950	2.83	981	2.97	1010	3.12	1035	3.26	1058	3.39
4800	902	2.75	934	2.90	965	3.06	995	3.21	1022	3.36	1046	3.51	1068	3.64
5000	918	2.98	948	3.14	979	3.30	1008	3.46	1034	3.61	1057	3.76	1077	3.89

## BLOWER DATA

### TAA150 BLOWER PERFORMANCE

All data is measured external to the unit with dry coil and standard 2 in. air filters in place.

FOR ALL UNITS ADD:

1 - Wet indoor coil air resistance of selected unit.

2 - Any field installed accessories air resistance (electric heat, economizer, etc.) See page 17.

Then determine from table the blower motor hp and drive rpm required. See page 16 for blower drive specifications.

Air Volume cfm	STATIC PRESSURE EXTERNAL TO UNIT - Inches Water Gauge															
	0.1		0.2		0.3		0.4		0.5		0.6		0.7		0.8	
	RPM	BHP	RPM	BHP	RPM	BHP	RPM	BHP	RPM	BHP	RPM	BHP	RPM	BHP	RPM	BHP
2800	475	0.39	517	0.55	559	0.69	600	0.81	638	0.90	675	0.98	709	1.04	742	1.09
3000	487	0.49	529	0.65	571	0.79	612	0.91	650	1.00	687	1.07	721	1.13	752	1.19
3200	500	0.60	542	0.75	584	0.89	624	1.01	663	1.10	699	1.17	732	1.23	764	1.30
3400	513	0.71	555	0.86	597	1.00	638	1.11	676	1.20	711	1.28	745	1.35	775	1.42
3600	526	0.82	569	0.98	611	1.12	651	1.23	689	1.32	725	1.40	757	1.47	788	1.55
3800	540	0.93	583	1.10	626	1.24	666	1.36	704	1.45	739	1.53	771	1.61	801	1.69
4000	554	1.05	598	1.23	641	1.38	682	1.50	719	1.60	753	1.68	785	1.76	814	1.85
4200	569	1.18	614	1.37	658	1.53	698	1.65	735	1.75	768	1.84	799	1.92	828	2.02
4400	585	1.33	631	1.53	675	1.69	715	1.82	751	1.93	784	2.01	814	2.10	843	2.20
4600	603	1.50	650	1.71	694	1.88	733	2.01	769	2.11	800	2.20	829	2.29	858	2.40
4800	622	1.68	670	1.90	714	2.07	752	2.20	786	2.30	816	2.39	845	2.48	873	2.61
5000	643	1.89	691	2.11	734	2.28	771	2.40	804	2.50	833	2.59	860	2.69	888	2.82
5200	666	2.12	714	2.34	756	2.49	791	2.61	822	2.70	849	2.79	876	2.91	903	3.05
5400	691	2.37	738	2.57	777	2.72	810	2.82	839	2.91	865	3.01	891	3.13	919	3.29
5600	718	2.63	762	2.82	799	2.94	829	3.04	856	3.13	881	3.23	907	3.37	934	3.53
5800	746	2.91	786	3.06	820	3.17	848	3.26	872	3.36	896	3.47	922	3.62	949	3.80
6000	774	3.18	810	3.31	840	3.40	865	3.49	888	3.59	911	3.72	936	3.88	963	4.08

Air Volume cfm	STATIC PRESSURE EXTERNAL TO UNIT - Inches Water Gauge													
	0.9		1		1.1		1.2		1.3		1.4		1.5	
	RPM	BHP	RPM	BHP	RPM	BHP	RPM	BHP	RPM	BHP	RPM	BHP	RPM	BHP
2800	773	1.15	805	1.22	838	1.30	871	1.39	904	1.48	935	1.58	964	1.67
3000	783	1.26	815	1.34	848	1.43	881	1.52	914	1.62	944	1.72	973	1.82
3200	794	1.37	826	1.46	858	1.56	892	1.66	924	1.76	955	1.87	983	1.98
3400	806	1.50	837	1.60	870	1.70	903	1.81	935	1.92	965	2.04	994	2.15
3600	818	1.64	849	1.74	882	1.86	915	1.97	947	2.09	977	2.21	1004	2.33
3800	831	1.79	862	1.91	895	2.03	928	2.15	959	2.28	988	2.40	1015	2.52
4000	844	1.96	876	2.08	908	2.21	941	2.34	972	2.47	1000	2.60	1026	2.72
4200	858	2.14	890	2.27	922	2.40	954	2.54	984	2.68	1012	2.81	1037	2.94
4400	873	2.33	904	2.47	936	2.61	968	2.75	997	2.89	1024	3.03	1048	3.16
4600	887	2.53	919	2.68	950	2.83	981	2.97	1010	3.12	1035	3.26	1058	3.39
4800	902	2.75	934	2.90	965	3.06	995	3.21	1022	3.36	1046	3.51	1068	3.64
5000	918	2.98	948	3.14	979	3.30	1008	3.46	1034	3.61	1057	3.76	1077	3.89
5200	933	3.21	963	3.38	993	3.55	1020	3.72	1045	3.88	1067	4.02	1086	4.15
5400	948	3.46	978	3.64	1006	3.82	1033	3.99	1056	4.15	1077	4.30	1095	4.43
5600	963	3.72	992	3.91	1019	4.09	1044	4.27	1067	4.43	1086	4.58	1104	4.71
5800	977	3.99	1005	4.19	1032	4.38	1056	4.56	1077	4.73	1096	4.88	1114	5.01
6000	991	4.28	1019	4.49	1044	4.69	1067	4.87	1087	5.04	1106	5.19	1123	5.33

## BLOWER DATA

### TAA180 BLOWER PERFORMANCE

All data is measured external to the unit with dry coil and standard 2 in. air filters in place.

FOR ALL UNITS ADD:

1 - Wet indoor coil air resistance of selected unit.

2 - Any field installed accessories air resistance (electric heat, economizer, etc.) See page 17.

Then determine from table the blower motor hp and drive rpm required. See page 16 for blower drive specifications.

Air Volume cfm	STATIC PRESSURE EXTERNAL TO UNIT - Inches Water Gauge															
	0.1		0.2		0.3		0.4		0.5		0.6		0.7		0.8	
	RPM	BHP	RPM	BHP	RPM	BHP	RPM	BHP	RPM	BHP	RPM	BHP	RPM	BHP	RPM	BHP
3400	393	0.60	439	0.81	486	1.00	533	1.16	579	1.28	624	1.41	667	1.56	708	1.71
3600	398	0.66	444	0.87	491	1.06	538	1.21	583	1.33	628	1.47	671	1.62	711	1.79
3800	403	0.72	449	0.92	496	1.11	542	1.26	587	1.39	632	1.53	675	1.69	715	1.86
4000	408	0.78	454	0.98	501	1.17	547	1.32	592	1.45	636	1.60	679	1.76	718	1.94
4200	413	0.84	459	1.04	506	1.23	552	1.38	597	1.52	641	1.67	683	1.84	722	2.03
4400	419	0.90	465	1.10	512	1.29	558	1.44	602	1.58	645	1.74	687	1.92	726	2.12
4600	424	0.97	470	1.17	517	1.35	563	1.50	607	1.65	651	1.82	692	2.01	730	2.21
4800	430	1.03	476	1.23	523	1.42	569	1.57	613	1.73	656	1.90	697	2.10	735	2.31
5000	436	1.09	482	1.30	530	1.49	575	1.64	619	1.81	661	1.99	702	2.19	739	2.42
5200	442	1.15	489	1.37	536	1.56	582	1.72	625	1.89	667	2.08	707	2.29	744	2.52
5400	448	1.21	495	1.44	543	1.64	588	1.80	631	1.98	673	2.18	712	2.40	749	2.63
5600	454	1.28	502	1.52	550	1.72	595	1.89	638	2.08	679	2.28	718	2.51	754	2.75
5800	460	1.35	510	1.60	558	1.80	602	1.98	645	2.18	686	2.39	724	2.62	759	2.87
6000	467	1.43	517	1.68	566	1.89	610	2.07	652	2.28	692	2.50	729	2.74	764	2.99
6200	475	1.51	526	1.78	574	1.98	617	2.17	659	2.39	699	2.61	735	2.86	770	3.12
6400	483	1.60	534	1.87	582	2.08	625	2.28	666	2.50	705	2.73	741	2.99	775	3.25
6600	491	1.70	544	1.97	591	2.18	633	2.39	674	2.62	712	2.86	747	3.12	781	3.38
6800	501	1.81	553	2.08	600	2.29	642	2.51	682	2.74	719	2.99	753	3.26	786	3.52
7000	511	1.92	563	2.19	609	2.40	650	2.63	689	2.87	725	3.13	759	3.40	792	3.66
7200	521	2.04	573	2.30	618	2.52	659	2.76	697	3.01	732	3.27	765	3.54	798	3.80

Air Volume cfm	STATIC PRESSURE EXTERNAL TO UNIT - Inches Water Gauge															
	0.9		1		1.1		1.2		1.3		1.4		1.5			
	RPM	BHP	RPM	BHP	RPM	BHP	RPM	BHP	RPM	BHP	RPM	BHP	RPM	BHP		
3400	746	1.87	783	2.02	819	2.16	857	2.31	897	2.48	936	2.65	976	2.83		
3600	749	1.95	786	2.11	822	2.26	860	2.42	900	2.58	939	2.76	979	2.93		
3800	752	2.04	789	2.21	825	2.36	863	2.52	903	2.69	943	2.86	983	3.04		
4000	756	2.13	792	2.30	829	2.47	867	2.63	906	2.80	946	2.97	986	3.15		
4200	759	2.22	795	2.40	832	2.57	870	2.74	910	2.91	950	3.08	990	3.26		
4400	763	2.32	799	2.51	836	2.68	874	2.85	913	3.02	953	3.19	993	3.37		
4600	767	2.42	803	2.61	840	2.79	878	2.96	917	3.13	957	3.31	997	3.48		
4800	771	2.53	807	2.72	844	2.91	882	3.08	921	3.25	961	3.42	1001	3.59		
5000	775	2.63	811	2.84	848	3.02	886	3.20	925	3.37	965	3.54	1005	3.71		
5200	780	2.75	815	2.95	852	3.14	890	3.32	929	3.49	969	3.67	1009	3.84		
5400	784	2.86	820	3.07	857	3.26	895	3.44	934	3.62	974	3.80	1014	3.97		
5600	789	2.98	824	3.19	861	3.38	900	3.57	939	3.75	978	3.93	1018	4.11		
5800	794	3.10	829	3.32	866	3.51	905	3.70	944	3.88	983	4.07	1023	4.25		
6000	799	3.23	834	3.44	871	3.64	910	3.83	949	4.02	988	4.21	1028	4.40		
6200	804	3.36	839	3.57	876	3.77	915	3.97	954	4.16	994	4.35	1033	4.55		
6400	809	3.49	844	3.70	881	3.90	920	4.10	960	4.30	999	4.50	1039	4.70		
6600	815	3.62	850	3.83	887	4.04	926	4.24	965	4.45	1005	4.65	1044	4.85		
6800	820	3.76	855	3.97	892	4.18	931	4.39	971	4.59	1011	4.80	1050	5.01		
7000	826	3.89	861	4.11	898	4.32	937	4.53	977	4.74	1016	4.95	1056	5.16		
7200	831	4.03	866	4.25	904	4.46	943	4.67	982	4.89	1022	5.10	1062	5.32		

# BLOWER DATA

## TAA240 BLOWER PERFORMANCE

All data is measured external to the unit with dry coil and standard 2 in. air filters in place.

FOR ALL UNITS ADD:

1 - Wet indoor coil air resistance of selected unit.

2 - Any field installed accessories air resistance (electric heat, economizer, etc.) See page 17.

Then determine from table the blower motor hp and drive rpm required. See page 16 for blower drive specifications.

Air Volume cfm	STATIC PRESSURE EXTERNAL TO UNIT - Inches Water Gauge															
	0.1		0.2		0.3		0.4		0.5		0.6		0.7		0.8	
	RPM	BHP	RPM	BHP	RPM	BHP	RPM	BHP	RPM	BHP	RPM	BHP	RPM	BHP	RPM	BHP
4400	449	1.05	493	1.22	539	1.38	584	1.52	628	1.68	670	1.85	711	2.04	748	2.24
4600	456	1.11	501	1.29	546	1.45	591	1.60	635	1.76	677	1.94	717	2.14	754	2.35
4800	463	1.17	509	1.36	554	1.53	599	1.68	642	1.85	684	2.03	723	2.24	760	2.46
5000	471	1.24	517	1.44	563	1.60	607	1.76	650	1.94	691	2.14	729	2.35	766	2.58
5200	479	1.32	525	1.52	571	1.69	615	1.85	657	2.04	698	2.24	736	2.47	772	2.70
5400	487	1.40	534	1.60	580	1.77	623	1.95	665	2.14	705	2.36	743	2.59	778	2.82
5600	496	1.48	544	1.69	589	1.87	632	2.05	674	2.25	713	2.48	749	2.72	785	2.95
5800	506	1.58	554	1.79	599	1.96	641	2.16	682	2.37	720	2.60	756	2.85	791	3.08
6000	516	1.68	564	1.89	608	2.07	650	2.27	691	2.49	728	2.73	763	2.98	798	3.22
6200	527	1.78	574	1.99	618	2.18	660	2.39	699	2.62	736	2.87	771	3.12	805	3.36
6400	538	1.89	585	2.09	628	2.29	669	2.51	708	2.75	743	3.01	778	3.26	812	3.50
6600	550	2.00	596	2.21	638	2.41	679	2.64	716	2.89	751	3.15	785	3.41	819	3.65
6800	562	2.12	607	2.33	649	2.54	688	2.78	725	3.04	759	3.30	793	3.56	826	3.79
7000	574	2.24	619	2.45	659	2.68	698	2.93	733	3.19	767	3.46	800	3.71	834	3.95
7200	587	2.36	630	2.59	670	2.83	707	3.08	742	3.34	775	3.61	808	3.87	841	4.10
7400	600	2.50	642	2.73	680	2.98	717	3.23	750	3.50	783	3.77	815	4.03	849	4.25
7600	612	2.64	653	2.88	691	3.13	726	3.40	759	3.67	791	3.94	823	4.19	856	4.41
7800	625	2.79	664	3.03	701	3.29	735	3.56	767	3.84	799	4.10	831	4.35	864	4.56
8000	638	2.94	676	3.20	711	3.46	744	3.73	776	4.01	807	4.27	839	4.51	872	4.72
8200	650	3.11	687	3.36	721	3.63	753	3.91	784	4.18	815	4.44	847	4.67	880	4.88
8400	662	3.27	698	3.54	731	3.81	762	4.08	793	4.36	823	4.61	855	4.84	888	5.04
8600	674	3.45	708	3.72	740	3.99	771	4.26	801	4.54	832	4.79	863	5.00	896	5.20
8800	685	3.63	719	3.90	750	4.17	780	4.45	809	4.72	840	4.96	871	5.17	904	5.36
9000	697	3.81	729	4.09	759	4.36	788	4.63	818	4.90	848	5.13	880	5.34	913	5.52
9200	708	4.00	739	4.28	768	4.55	797	4.82	826	5.08	857	5.30	888	5.50	921	5.69
9400	718	4.20	748	4.47	777	4.74	806	5.01	835	5.26	865	5.48	897	5.67	929	5.85
9600	729	4.39	758	4.67	786	4.94	814	5.20	843	5.44	874	5.65	905	5.84	938	6.01

Air Volume cfm	STATIC PRESSURE EXTERNAL TO UNIT - Inches Water Gauge													
	0.9		1		1.1		1.2		1.3		1.4		1.5	
	RPM	BHP	RPM	BHP	RPM	BHP	RPM	BHP	RPM	BHP	RPM	BHP	RPM	BHP
4400	785	2.44	821	2.61	858	2.78	897	2.93	936	3.09	977	3.24	1017	3.40
4600	790	2.55	826	2.73	864	2.90	902	3.06	942	3.21	982	3.37	1022	3.53
4800	796	2.66	832	2.85	869	3.02	908	3.18	948	3.34	988	3.50	1028	3.66
5000	801	2.79	837	2.97	875	3.14	914	3.31	954	3.48	994	3.64	1034	3.81
5200	807	2.91	843	3.10	881	3.27	920	3.45	960	3.62	1000	3.79	1040	3.96
5400	813	3.04	850	3.23	888	3.41	927	3.58	967	3.76	1007	3.94	1047	4.11
5600	820	3.17	856	3.36	894	3.54	934	3.73	974	3.91	1014	4.09	1053	4.27
5800	826	3.30	863	3.49	901	3.68	941	3.87	981	4.06	1021	4.24	1060	4.43
6000	833	3.43	869	3.63	908	3.82	948	4.01	988	4.21	1028	4.40	1068	4.59
6200	840	3.57	876	3.77	915	3.96	955	4.16	995	4.36	1035	4.55	1075	4.75
6400	847	3.71	883	3.91	922	4.11	962	4.31	1002	4.51	1042	4.71	1082	4.91
6600	854	3.86	890	4.06	929	4.25	969	4.45	1009	4.66	1049	4.86	1089	5.06
6800	861	4.00	898	4.20	936	4.40	976	4.60	1016	4.80	1056	5.00	1096	5.20
7000	868	4.15	905	4.35	943	4.54	983	4.74	1023	4.94	1063	5.14	1103	5.34
7200	876	4.30	912	4.50	950	4.69	990	4.88	1030	5.08	1070	5.28	1110	5.48
7400	883	4.45	920	4.64	958	4.83	997	5.03	1037	5.22	1077	5.42	1117	5.62
7600	891	4.61	927	4.79	965	4.98	1004	5.17	1044	5.37	1084	5.56	1124	5.76
7800	899	4.76	935	4.95	973	5.13	1012	5.32	1051	5.51	1091	5.71	1131	5.90
8000	907	4.91	943	5.10	980	5.28	1019	5.47	1059	5.66	1098	5.85	1138	6.04
8200	914	5.07	950	5.25	988	5.43	1027	5.62	1066	5.80	1106	5.99	1145	6.18
8400	922	5.23	958	5.41	996	5.58	1034	5.77	1073	5.95	1113	6.14	1153	6.33
8600	930	5.38	966	5.56	1003	5.74	1042	5.92	1081	6.10	1120	6.28	1160	6.47
8800	938	5.54	974	5.71	1011	5.89	1049	6.07	1088	6.25	1128	6.43	1167	6.62
9000	947	5.70	982	5.87	1019	6.04	1057	6.22	1096	6.40	1135	6.58	1175	6.76
9200	955	5.86	990	6.03	1027	6.20	1065	6.37	1104	6.54	1143	6.72	1182	6.91
9400	963	6.02	998	6.18	1035	6.35	1073	6.52	1111	6.69	1150	6.87	1190	7.05
9600	971	6.18	1007	6.34	1043	6.50	1081	6.67	1119	6.84	1158	7.02	1197	7.20

## BLOWER DATA

### BLOWER DRIVE SPECIFICATIONS

Static	RPM Range	Motor HP		072	090	120	150	180	240
		Nominal	Maximum						
Low	552 - 782	1.5	1.72	O	---	---	---	---	---
Standard	690 - 936	1.5	1.72	S	---	---	---	---	---
High	906 - 1121	2	2.3	O	---	---	---	---	---
Low	644 - 874	2	2.3	---	O	---	---	---	---
Standard	782 - 1012	2	2.3	---	S	---	---	---	---
High	966 - 1196	3	3.45	---	O	---	---	---	---
Low	690 - 893	2	2.3	---	---	O	---	---	---
Standard	852 - 1055	2	2.3	---	---	S	---	---	---
High	986 - 1232	3	3.45	---	---	O	---	---	---
Low	782 - 1012	3	3.45	---	---	---	O	---	---
Standard	920 - 1150	3	3.45	---	---	---	S	---	---
High	1134 - 1380	5	5.75	---	---	---	O	---	---
Low	591 - 838	3	3.45	---	---	---	---	O	---
Standard	782 - 1012	5	5.75	---	---	---	---	S	---
High	920 - 1150	5	5.75	---	---	---	---	O	---
Low	679 - 863	5	5.75	---	---	---	---	---	O
Standard	808 - 1026	7.5	8.63	---	---	---	---	---	S
High	1002 - 1282	7.5	8.63	---	---	---	---	---	O

NOTE - Using total air volume and system static pressure requirements, determine from blower performance tables rpm and motor horsepower required.

Maximum usable horsepower of motors furnished by Lennox are shown. In Canada, nominal motor horsepower is also maximum usable motor horsepower. If motors of comparable horsepower are used, be sure to keep within the service factor limitations outlined on the motor nameplate.

S - Factory installed standard

O - Factory Installed with extended lead time.

### BLOWER MOTOR ELECTRICAL DATA

		Model No.	072	090	120	150	180	240
<b>1.5 HP Blower Motor</b>	Maximum Overcurrent Protection / Minimum Circuit Ampacity	208/230/-60hz-3ph	15 / 8	---	---	---	---	---
		460V-60hz-3ph	15 / 4	---	---	---	---	---
		575V-60hz-3ph	15 / 3	---	---	---	---	---
	Blower Motor Full Load Amps	208/230/-60hz-3ph	5.7	---	---	---	---	---
		460V-60hz-3ph	3	---	---	---	---	---
		575V-60hz-3ph	2.4	---	---	---	---	---
<b>2 HP Blower Motor</b>	Maximum Overcurrent Protection / Minimum Circuit Ampacity	208/230/-60hz-3ph	15 / 10	15 / 10	15 / 10	---	---	---
		460V-60hz-3ph	15 / 5	15 / 5	15 / 5	---	---	---
		575V-60hz-3ph	15 / 4	15 / 4	15 / 4	---	---	---
	Blower Motor Full Load Amps	208/230/-60hz-3ph	7.5	7.5	7.5	---	---	---
		460V-60hz-3ph	3.4	3.4	3.4	---	---	---
		575V-60hz-3ph	2.7	2.7	2.7	---	---	---
<b>3 HP Blower Motor</b>	Maximum Overcurrent Protection / Minimum Circuit Ampacity	208/230/-60hz-3ph	---	20 / 14	20 / 14	20 / 14	20 / 14	---
		460V-60hz-3ph	---	15 / 6	15 / 6	15 / 6	15 / 6	---
		575V-60hz-3ph	---	15 / 5	15 / 5	15 / 5	15 / 5	---
	Blower Motor Full Load Amps	208/230/-60hz-3ph	---	10.6	10.6	10.6	10.6	---
		460V-60hz-3ph	---	4.8	4.8	4.8	4.8	---
		575V-60hz-3ph	---	3.9	3.9	3.9	3.9	---
<b>5 HP Blower Motor</b>	Maximum Overcurrent Protection / Minimum Circuit Ampacity	208/230/-60hz-3ph	---	---	---	35 / 21	35 / 21	35 / 21
		460V-60hz-3ph	---	---	---	15 / 10	15 / 10	15 / 10
		575V-60hz-3ph	---	---	---	15 / 8	15 / 8	15 / 8
	Blower Motor Full Load Amps	208/230/-60hz-3ph	---	---	---	16.7	16.7	16.7
		460V-60hz-3ph	---	---	---	7.6	7.6	7.6
		575V-60hz-3ph	---	---	---	6.1	6.1	6.1
<b>7.5 HP Blower Motor</b>	Maximum Overcurrent Protection / Minimum Circuit Ampacity	208/230/-60hz-3ph	---	---	---	---	---	50 / 31
		460V-60hz-3ph	---	---	---	---	---	20 / 14
		575V-60hz-3ph	---	---	---	---	---	20 / 12
	Blower Motor Full Load Amps	208/230/-60hz-3ph	---	---	---	---	---	24.2
		460V-60hz-3ph	---	---	---	---	---	11
		575V-60hz-3ph	---	---	---	---	---	9



## BLOWER DATA

### TAA072-090 ACCESSORY AIR RESISTANCE

Air Volume (cfm)	Total Resistance - in. w.g.						
	Wet Coil		5 Inch Filters		Economizer	Electric Heat	Hot Water Coil
	072	090	MERV 11	MERV 16			
1600	0.05	0.07	0.02	0.04	0.02	0.00	0.08
1700	0.06	0.08	0.02	0.04	0.03	0.00	0.09
1800	0.06	0.09	0.02	0.04	0.03	0.00	0.10
1900	0.07	0.09	0.03	0.04	0.04	0.02	0.12
2000	0.07	0.10	0.03	0.04	0.04	0.02	0.13
2100	0.08	0.11	0.03	0.04	0.04	0.02	0.14
2200	0.08	0.11	0.03	0.05	0.05	0.02	0.15
2300	0.09	0.12	0.03	0.05	0.05	0.03	0.16
2400	0.10	0.13	0.04	0.06	0.05	0.03	0.17
2500	0.10	0.14	0.04	0.06	0.06	0.03	0.18
2600	0.11	0.15	0.04	0.06	0.06	0.03	0.19
2700	0.12	0.16	0.05	0.06	0.07	0.04	0.20
2800	0.12	0.17	0.05	0.06	0.07	0.04	0.21
2900	0.13	0.18	0.05	0.07	0.08	0.04	0.23
3000	0.14	0.19	0.05	0.07	0.08	0.05	0.24
3100	0.14	0.20	0.06	0.07	0.09	0.05	0.25
3200	0.15	0.21	0.06	0.07	0.09	0.05	0.27
3300	0.16	0.22	0.06	0.08	0.10	0.06	0.28
3400	0.17	0.23	0.06	0.08	0.10	0.06	0.29
3500	0.18	0.24	0.07	0.08	0.11	0.06	0.31
3600	0.18	0.25	0.07	0.08	0.12	0.06	0.32

### TAA120-150 ACCESSORY AIR RESISTANCE

Air Volume (cfm)	Total Resistance - in. w.g.						
	Wet Coil		5 Inch Filters		Economizer	Electric Heat	Hot Water Coil
	120	150	MERV 11	MERV 16			
2200	0.07	0.07	0.02	0.04	0.03	0.03	0.15
2400	0.08	0.08	0.03	0.04	0.03	0.03	0.17
2600	0.09	0.09	0.03	0.05	0.03	0.04	0.20
2800	0.10	0.10	0.03	0.05	0.04	0.04	0.22
3000	0.11	0.11	0.03	0.05	0.04	0.05	0.24
3200	0.12	0.12	0.04	0.05	0.04	0.05	0.27
3400	0.14	0.14	0.04	0.06	0.05	0.06	0.29
3600	0.15	0.15	0.05	0.06	0.05	0.06	0.32
3800	0.16	0.16	0.05	0.07	0.05	0.06	0.35
4000	0.18	0.18	0.06	0.07	0.06	0.08	0.38
4200	0.19	0.19	0.06	0.07	0.06	0.08	0.41
4400	0.20	0.20	0.06	0.08	0.07	0.09	0.44
4600	0.22	0.22	0.07	0.08	0.07	0.09	0.47
4800	0.23	0.23	0.07	0.08	0.08	0.10	0.51
5000	0.25	0.25	0.07	0.08	0.08	0.10	0.54
5200	0.27	0.27	0.08	0.09	0.09	0.11	0.58
5400	0.28	0.28	0.08	0.09	0.09	0.11	0.61
5600	0.30	0.30	0.08	0.09	0.10	0.13	0.65
5800	0.32	0.32	0.09	0.10	0.10	0.13	0.69
6000	0.33	0.33	0.09	0.10	0.11	0.14	0.72

## BLOWER DATA

### TAA180-240 ACCESSORY AIR RESISTANCE

Air Volume (cfm)	Total Resistance - in. w.g.						
	Wet Coil		5 Inch Filters		Economizer	Electric Heat	Hot Water Coil
	180	240	MERV 11	MERV 16			
3250	0.07	0.06	0.01	0.04	0.02	0.04	0.16
3500	0.07	0.07	0.01	0.04	0.02	0.05	0.18
3750	0.08	0.08	0.01	0.04	0.03	0.06	0.20
4000	0.08	0.09	0.01	0.04	0.03	0.06	0.22
4250	0.09	0.09	0.02	0.05	0.03	0.07	0.23
4500	0.08	0.11	0.03	0.05	0.05	0.06	0.24
4750	0.09	0.12	0.04	0.05	0.06	0.08	0.26
5000	0.10	0.13	0.04	0.06	0.07	0.09	0.28
5250	0.11	0.14	0.04	0.06	0.07	0.09	0.31
5500	0.11	0.15	0.05	0.06	0.08	0.11	0.33
5750	0.12	0.16	0.05	0.06	0.08	0.11	0.35
6000	0.13	0.18	0.05	0.07	0.10	0.12	0.38
6250	0.14	0.19	0.06	0.07	0.11	0.14	0.40
6500	0.15	0.20	0.06	0.07	0.11	0.14	0.43
6750	0.16	0.21	0.06	0.08	0.12	0.15	0.46
7000	0.17	0.22	0.07	0.08	0.12	0.15	0.48
7250	0.18	0.24	0.07	0.08	0.13	0.17	0.51
7500	0.19	0.25	0.07	0.08	0.13	0.17	0.54
7750	0.19	0.26	0.08	0.09	0.14	0.18	0.57
8000	0.21	0.28	0.08	0.09	0.16	0.20	0.60
8250	0.22	0.29	0.08	0.09	0.16	0.20	0.63
8500	0.23	0.31	0.09	0.10	0.17	0.21	0.66
8750	0.24	0.32	0.09	0.10	0.17	0.21	0.69
9000	0.25	0.33	0.09	0.10	0.18	0.23	0.72
9250	0.26	0.35	0.10	0.11	0.19	0.24	0.76
9500	0.27	0.36	0.10	0.11	0.20	0.26	0.79
9750	0.28	0.38	0.10	0.11	0.22	0.27	0.82
10,000	0.29	0.40	0.11	0.12	0.23	0.29	0.86

## TAA072 OPTIONAL ELECTRIC HEAT DATA

Electric Heat Size	No. of Steps	Volts Input	kW Input	1 Btuh Output	2 Total Unit + Electric Heat Minimum Circuit Ampacity		Total Unit + Electric Heat Maximum Overcurrent Protection	
					1.5 hp	2 hp	1.5 hp	2 hp
10 kW	1	208	7.5	25,600	34	36	35	40
	1	220	8.4	28,700	38	40	40	40
		230	9.2	31,400				
		240	10	34,100				
	1	440	8.4	28,700	19	20	20	20
		460	9.2	31,400				
		480	10	34,100				
	1	550	8.4	28,700	15	16	15	20
		575	9.2	31,400				
600		10	34,100					
15 kW	1	208	11.3	38,400	47	49	50	50
	1	220	12.6	43,000	53	55	60	60
		230	13.5	47,000				
		240	15	51,200				
	1	440	12.6	43,000	27	27	30	30
		460	13.5	47,000				
		480	15	51,200				
	1	550	12.6	43,000	21	22	25	25
		575	13.5	47,000				
600		15	51,200					
25 kW	<sup>3</sup> 2	208	18.8	64,100	73	75	80	80
	<sup>3</sup> 2	220	21	71,700	83	85	90	90
		230	23	78,300				
		240	25	85,300				
	1	440	21	71,700	42	42	45	45
		460	23	78,300				
		480	25	85,300				
	1	550	21	71,700	34	34	35	35
		575	23	78,300				
600		25	85,300					

<sup>1</sup> Electric heater capacity only - does not include additional blower motor heat capacity.

<sup>2</sup> Refer to National or Canadian Electrical Code manual to determine wire, fuse and disconnect size requirements. Use wires suitable for at least 167°F.

<sup>3</sup> May be used with two stage control (field provided).

## TAA090 OPTIONAL ELECTRIC HEAT DATA

Electric Heat Size	No. of Steps	Volts Input	kW Input	1 Btuh Output	<sup>2</sup> Total Unit + Electric Heat Minimum Circuit Ampacity		Total Unit + Electric Heat Maximum Overcurrent Protection	
					2 hp	3 hp	2 hp	3 hp
<b>10 kW</b>	1	208	7.5	25,600	36	40	40	40
	1	220	8.4	28,700	40	44	40	45
		230	9.2	31,400				
		240	10	34,100				
	1	440	8.4	28,700	20	21	20	25
		460	9.2	31,400				
		480	10	34,100				
	1	550	8.4	28,700	16	17	20	20
		575	9.2	31,400				
600		10	34,100					
<b>15 kW</b>	1	208	11.3	38,400	49	53	50	60
	1	220	12.6	43,000	55	59	60	60
		230	13.5	47,000				
		240	15	51,200				
	1	440	12.6	43,000	27	29	30	30
		460	13.5	47,000				
		480	15	51,200				
	1	550	12.6	43,000	22	23	25	25
		575	13.5	47,000				
600		15	51,200					
<b>25 kW</b>	<sup>3</sup> 2	208	18.8	64,100	75	79	80	80
	<sup>3</sup> 2	220	21	71,700	85	89	90	90
		230	23	78,300				
		240	25	85,300				
	1	440	21	71,700	42	44	45	45
		460	23	78,300				
		480	25	85,300				
	1	550	21	71,700	34	35	35	35
		575	23	78,300				
600		25	85,300					
<b>35 kW</b>	<sup>3</sup> 2	208	25	85,300	97	100	100	100
	<sup>3</sup> 2	220	28	95,500	110	114	110	125
		230	30.6	104,400				
		240	33.3	113,700				
	1	440	28	95,500	55	57	60	60
		460	30.6	104,400				
		480	33.3	113,700				
	1	550	28	95,500	44	45	45	45
		575	30.6	104,400				
600		33.3	113,700					

<sup>1</sup> Electric heater capacity only - does not include additional blower motor heat capacity.

<sup>2</sup> Refer to National or Canadian Electrical Code manual to determine wire, fuse and disconnect size requirements. Use wires suitable for at least 167°F.

<sup>3</sup> May be used with two stage control (field provided).

## TAA120 OPTIONAL ELECTRIC HEAT DATA

Electric Heat Size	No. of Steps	Volts Input	kW Input	1 Btuh Output	2 Total Unit + Electric Heat Minimum Circuit Ampacity		Total Unit + Electric Heat Maximum Overcurrent Protection	
					2 hp	3 hp	2 hp	3 hp
10 kW	1	208	7.5	25,600	36	40	40	40
	1	220	8.4	28,700	40	44	40	45
		230	9.2	31,400				
		240	10	34,100				
	1	440	8.4	28,700	20	21	20	25
		460	9.2	31,400				
		480	10	34,100				
	1	550	8.4	28,700	16	17	20	20
		575	9.2	31,400				
600		10	34,100					
15 kW	1	208	11.3	38,400	49	53	50	60
	1	220	12.6	43,000	55	59	60	60
		230	13.5	47,000				
		240	15	51,200				
	1	440	12.6	43,000	27	29	30	30
		460	13.5	47,000				
		480	15	51,200				
	1	550	12.6	43,000	22	23	25	25
		575	13.5	47,000				
600		15	51,200					
25 kW	<sup>3</sup> 2	208	18.8	64,100	75	79	80	80
	<sup>3</sup> 2	220	21	71,700	85	89	90	90
		230	23	78,300				
		240	25	85,300				
	1	440	21	71,700	42	44	45	45
		460	23	78,300				
		480	25	85,300				
	1	550	21	71,700	34	35	35	35
		575	23	78,300				
600		25	85,300					
35 kW	<sup>3</sup> 2	208	25	85,300	97	100	100	100
	<sup>3</sup> 2	220	28	95,500	110	114	110	125
		230	30.6	104,400				
		240	33.3	113,700				
	1	440	28	95,500	55	57	60	60
		460	30.6	104,400				
		480	33.3	113,700				
	1	550	28	95,500	44	45	45	45
		575	30.6	104,400				
600		33.3	113,700					

<sup>1</sup> Electric heater capacity only - does not include additional blower motor heat capacity.

<sup>2</sup> Refer to National or Canadian Electrical Code manual to determine wire, fuse and disconnect size requirements. Use wires suitable for at least 167°F.

<sup>3</sup> May be used with two stage control (field provided).

## TAA150 OPTIONAL ELECTRIC HEAT DATA

Electric Heat Size	No. of Steps	Volts Input	kW Input	1 Btuh Output	2 Total Unit + Electric Heat Minimum Circuit Ampacity		Total Unit + Electric Heat Maximum Overcurrent Protection		
					3 hp	5 hp	3 hp	5 hp	
10 kW	1	208	7.5	25,600	40	47	40	50	
	1	220	8.4	28,700	44	51	45	60	
		230	9.2	31,400					
		240	10	34,100					
			440	8.4	28,700	21	25	25	25
	1	460	9.2	31,400					
		480	10	34,100					
	1	550	8.4	28,700	17	20	20	20	
575		9.2	31,400						
		600	10	34,100					
15 kW	1	208	11.3	38,400	53	60	60	60	
	1	220	12.6	43,000	59	66	60	70	
		230	13.5	47,000					
		240	15	51,200					
			440	12.6	43,000	29	32	30	35
	1	460	13.5	47,000					
		480	15	51,200					
	1	550	12.6	43,000	23	26	25	30	
575		13.5	47,000						
600		15	51,200						
25 kW	<sup>3</sup> 2	208	18.8	64,100	79	86	80	90	
	<sup>3</sup> 2	220	21	71,700	89	96	90	100	
		230	23	78,300					
		240	25	85,300					
			440	21	71,700	44	48	45	50
	1	460	23	78,300					
		480	25	85,300					
	1	550	21	71,700	35	38	35	40	
575		23	78,300						
600		25	85,300						
35 kW	<sup>3</sup> 2	208	25	85,300	100	108	100	110	
	<sup>3</sup> 2	220	28	95,500	114	121	125	125	
		230	30.6	104,400					
		240	33.3	113,700					
			440	28	95,500	57	60	60	60
	1	460	30.6	104,400					
		480	33.3	113,700					
	1	550	28	95,500	45	48	45	50	
575		30.6	104,400						
600		33.3	113,700						

<sup>1</sup> Electric heater capacity only - does not include additional blower motor heat capacity.

<sup>2</sup> Refer to National or Canadian Electrical Code manual to determine wire, fuse and disconnect size requirements. Use wires suitable for at least 167°F.

<sup>3</sup> May be used with two stage control (field provided).

## TAA180 OPTIONAL ELECTRIC HEAT DATA

Electric Heat Size	No. of Steps	Volts Input	kW Input	1 Btuh Output	2 Total Unit + Electric Heat Minimum Circuit Ampacity		Total Unit + Electric Heat Maximum Overcurrent Protection	
					3 hp	5 hp	3 hp	5 hp
20 kW	1	208	14.8	50,600	65	73	70	80
	1	220	16.5	56,500	73	81	80	90
		230	18.1	61,800				
		240	19.7	67,300				
	1	440	16.8	57,500	37	40	40	40
		460	18.4	62,900				
		480	20	68,300				
	1	550	16.8	57,300	29	32	30	35
		575	18.4	62,600				
600		20	68,300					
30 kW	2	208	22.5	76,900	92	99	100	100
	2	220	25.2	86,100	104	112	110	125
		230	27.5	94,100				
		240	30	102,500				
	1	440	25.2	86,100	52	55	60	60
		460	27.5	94,100				
		480	30	102,500				
	1	550	25.2	86,200	41	44	45	45
		575	27.5	94,200				
600		30	102,500					
40 kW	2	208	29.3	100,000	115	123	125	125
	2	220	32.8	112,000	131	139	150	150
		230	35.8	122,300				
		240	39	133,200				
	1	440	32.8	112,000	65	69	70	70
		460	35.9	122,400				
		480	39	133,200				
	1	550	33.6	114,800	53	56	60	60
		575	36.7	125,500				
600		40	136,600					
50 kW	2	208	36.1	123,200	114	121	125	125
	2	220	40.3	137,700	129	137	150	150
		230	44.1	150,600				
		240	48	163,900				
	2	440	42	143,400	74	81	80	90
		460	45.9	156,700				
		480	50	170,800				
	2	550	42	143,500	62	69	70	70
		575	45.9	156,800				
600		50	170,800					

<sup>1</sup> Electric heater capacity only - does not include additional blower motor heat capacity.

<sup>2</sup> Refer to National or Canadian Electrical Code manual to determine wire, fuse and disconnect size requirements. Use wires suitable for at least 167°F.

## TAA240 OPTIONAL ELECTRIC HEAT DATA

Electric Heat Size	No. of Steps	Volts Input	kW Input	1 Btuh Output	2 Total Unit + Electric Heat Minimum Circuit Ampacity		Total Unit + Electric Heat Maximum Overcurrent Protection	
					5 hp	7.5 hp	5 hp	7.5 hp
20 kW	1	208	14.8	50,600	73	82	80	90
	1	220	16.5	56,500	81	90	90	90
		230	18.1	61,800				
		240	19.7	67,300				
	1	440	16.8	57,500	40	44	40	45
		460	18.4	62,900				
		480	20	68,300				
	1	550	16.7	57,300	32	36	35	40
		575	18.4	62,600				
600		20	68,300					
30 kW	2	208	22.5	76,900	99	109	100	110
	2	220	25.2	86,100	112	121	125	125
		230	27.6	94,100				
		240	30	102,500				
	1	440	25.2	86,100	55	59	60	60
		460	27.6	94,100				
		480	30	102,500				
	1	550	25.2	86,100	44	48	45	50
		575	27.6	94,200				
600		30	102,500					
40 kW	2	208	29.3	100,000	123	132	125	150
	2	220	32.8	112,000	139	148	150	150
		230	35.8	122,300				
		240	39	133,200				
	1	440	32.8	112,000	69	73	70	80
		460	35.9	122,400				
		480	39	133,200				
	1	550	33.6	114,800	56	60	60	60
		575	36.7	125,500				
600		40	136,600					
50 kW	2	208	36.1	123,200	121	131	125	150
	2	220	40.3	137,700	137	146	150	150
		230	44.1	150,600				
		240	48	163,900				
	2	440	42	143,400	81	91	90	100
		460	45.9	156,700				
		480	50	170,800				
	2	550	42	143,500	69	79	70	80
		575	45.9	156,800				
600		50	170,800					

<sup>1</sup> Electric heater capacity only - does not include additional blower motor heat capacity.

<sup>2</sup> Refer to National or Canadian Electrical Code manual to determine wire, fuse and disconnect size requirements. Use wires suitable for at least 167°F.



## SPECIFICATIONS - HOT WATER COIL

General Data	Hot Water Coil Model No.	T2HWCL10LM1-	T2HWCL10N-1-
	Air Handler Model No.	TAA072 TAA090 TAA120 TAA150	TAA180 TAA240
Water Line Connections	Inlet o.d. - in. (sweat)	1-3/8	1-3/8
	Outlet o.d. - in. (sweat)	1-3/8	1-3/8
Hot Water Coil	Net face area - sq. ft.	6.00	9.00
	Tube diameter - in.	3/8	3/8
	Fins per inch	14	14

## HOT WATER COIL - WATER PRESSURE DROP

Model No.	Flow Rate (gpm)																	
	2	4	6	8	10	12	14	16	18	20	22	24	26	28	30	32	34	36
	Water Pressure Drop (ft. of water)																	
TAA072 TAA090 TAA120 TAA150	0.02	0.10	0.20	0.33	0.49	0.67	0.87	1.10	1.35	1.62	1.91	2.23	2.57	2.92	3.30	3.70	4.11	4.55
TAA180 TAA240	0.03	0.15	0.30	0.50	0.73	1.00	1.30	1.65	2.02	2.43	2.87	3.34	3.85	4.38	4.95	5.55	6.17	6.83

Model No.	Flow Rate (gpm)																
	38	40	42	44	46	48	50	52	54	56	58	60	62	64	66	68	70
	Water Pressure Drop (ft. of water)																
TAA072 TAA090 TAA120 TAA150	5.01	5.48	5.98	6.49	7.02	7.57	8.14	8.73	9.33	9.96	10.60	11.26	11.93	12.63	13.34	14.07	14.82
TAA180 TAA240	7.51	8.22	8.97	9.74	10.53	11.36	12.21	13.09	14.00	14.94	15.90	16.89	17.90	18.94	20.01	21.10	22.22

**HOT WATER COIL CAPACITIES - 072-150**

Model No.	Air Flow (cfm)	Enter- ing Air Temp (°F)	Entering Water Temperature (°F)																																																																																																																																																																																																																																																																																																																																																																																																																																																																																																																																																																																																																																																																																																																																																																																																																																																																																																																																																																																																																																																																																																																																																																																																																																																																			
			140						160						180																																																																																																																																																																																																																																																																																																																																																																																																																																																																																																																																																																																																																																																																																																																																																																																																																																																																																																																																																																																																																																																																																																																																																																																																																																																							
			20		30		40		20		30		40		20		30		40																																																																																																																																																																																																																																																																																																																																																																																																																																																																																																																																																																																																																																																																																																																																																																																																																																																																																																																																																																																																																																																																																																																																																																																																																																																			
			GPM	LAT	GPM	MBh	LAT	MBh	GPM	LAT	GPM	MBh	LAT	MBh	GPM	LAT	GPM	MBh	LAT	MBh	GPM	LAT	GPM	MBh	LAT																																																																																																																																																																																																																																																																																																																																																																																																																																																																																																																																																																																																																																																																																																																																																																																																																																																																																																																																																																																																																																																																																																																																																																																																																																													
072	1920	40	12.8	126.5	100	7.8	115.8	95	5.3	104.4	90	15.9	156.9	115	9.9	146.6	110	6.9	136.0	105	19.1	186.9	129	12.1	177.2	125	8.5	167.1	120	9.8	96.7	107	5.8	85.9	101	3.7	74.0	96	12.9	126.9	121	7.9	116.7	116	5.4	105.8	111	16.1	156.9	136	10.0	147.2	131	7.0	137.0	126	6.8	67.1	113	3.7	55.7	107	2.2	42.6	101	9.9	97.3	127	5.9	86.9	122	3.8	75.5	117	13.0	127.2	142	8.0	117.4	137	5.5	107.0	132	14.9	147.7	96	9.0	134.6	91	6.1	120.8	86	18.6	183.4	110	11.6	170.9	105	8.6	160.6	101	22.4	218.8	124	14.1	207.0	119	10.2	194.4	115	11.4	112.8	103	6.7	99.5	98	4.3	85.3	93	15.1	148.3	117	9.2	135.8	112	6.2	122.6	107	18.8	183.6	131	11.7	171.7	126	8.1	158.8	121	7.9	78.0	110	4.3	64.2	105	2.5	48.7	99	11.5	113.5	124	6.8	100.8	119	4.4	87.2	114	15.2	148.7	138	9.3	136.7	133	6.3	124.1	128	16.9	166.9	93	10.2	151.6	88	6.8	135.7	83	21.1	207.5	106	13.1	192.9	101	9.0	177.8	97	25.4	247.9	119	15.9	233.8	114	11.2	219.4	110	12.9	127.3	101	7.5	111.9	96	4.8	95.4	91	17.0	167.7	114	10.4	153.2	109	7.0	137.8	104	21.3	207.9	127	13.2	193.9	122	9.2	179.5	118	8.9	87.8	108	4.8	71.9	103	2.7	54.1	98	13.0	128.2	121	7.7	113.4	117	4.9	97.6	112	17.2	168.2	134	10.5	154.2	130	7.1	139.5	125	14.9	147.7	96	9.0	134.6	91	6.1	120.8	86	18.6	183.4	110	11.6	170.9	105	8.6	160.6	101	22.4	218.8	124	14.1	207.0	119	10.2	194.4	115	11.4	112.8	103	6.7	99.5	98	4.3	85.3	93	15.1	148.3	117	9.2	135.8	112	6.2	122.6	107	18.8	183.6	131	11.7	171.7	126	8.1	158.8	121	7.9	78.0	110	4.3	64.2	105	2.5	48.7	99	11.5	113.5	124	6.8	100.8	119	4.4	87.2	114	15.2	148.7	138	9.3	136.7	133	6.3	124.1	128	17.3	171.4	92	10.5	155.7	88	7.0	139.1	83	21.7	213.2	105	13.4	198.1	101	9.2	182.5	96	26.1	254.9	118	16.4	240.2	113	11.5	225.4	109	13.2	130.7	100	7.7	114.8	95	4.9	97.8	90	17.5	172.3	113	10.6	157.2	108	7.2	141.4	104	21.9	213.6	126	13.6	199.3	121	9.4	184.2	117	9.1	90.2	108	5.0	73.7	103	2.8	55.4	97	13.4	131.6	121	7.9	116.4	116	5.1	100.0	111	17.7	172.9	134	10.8	158.3	129	7.3	143.2	124	19.5	193.0	89	11.7	174.6	84	7.8	155.6	80	24.4	240.2	101	15.1	222.6	97	10.4	204.6	92	29.4	287.2	113	18.4	270.2	109	12.9	253.2	104	14.8	146.9	98	8.6	128.5	93	5.5	109.0	88	19.7	193.9	110	11.9	176.4	105	8.0	158.2	101	24.7	240.8	122	15.3	223.9	118	10.5	206.6	113	10.2	101.1	106	5.5	82.2	101	3.1	61.3	96	15.0	148.0	118	8.8	130.3	114	5.7	111.6	109	19.9	194.6	130	12.1	177.8	126	8.2	160.2	121	18.1	178.8	91	10.9	162.3	87	7.3	144.8	82	22.6	222.5	104	14.0	206.5	99	9.6	190.2	95	27.2	266.0	116	17.1	250.5	112	12.0	235.0	107	13.8	136.3	99	8.0	119.5	95	5.1	101.7	89	18.3	179.7	112	11.1	163.8	107	7.5	147.2	103	22.8	223.0	124	14.2	207.7	120	9.8	191.9	115	9.5	93.9	107	5.2	76.6	102	2.9	57.5	97	14.0	137.3	120	8.2	121.2	115	5.3	104.0	110	18.5	180.3	133	11.2	165.0	128	7.6	149.0	123	20.8	206.1	87	12.5	186.3	83	8.3	165.7	78	26.1	256.9	99	16.1	237.9	95	10.4	204.6	92	31.5	307.2	110	19.7	288.8	106	13.8	270.1	102	15.4	201.6	98	15.8	156.9	96	9.2	136.9	92	5.8	115.9	87	21.1	207.3	108	12.7	188.3	104	8.0	158.2	101	26.4	257.6	120	16.3	239.3	115	11.2	220.4	111	10.9	107.8	105	5.9	87.3	100	3.3	64.9	95	16.1	158.1	117	9.4	138.9	112	5.7	111.6	109	21.3	208.1	129	12.9	189.8	124	8.7	170.9	120	23.3	230.6	84	14.0	207.7	80	9.3	184.2	75	29.2	287.5	95	18.0	265.7	91	9.6	190.2	95	35.2	344.2	106	22.0	323.1	102	15.4	301.6	98	17.7	175.3	94	10.2	152.4	89	6.5	128.4	85	23.6	232.0	105	14.2	210.2	101	7.5	147.2	103	29.5	288.4	116	18.2	267.4	112	12.5	246.0	107	12.1	120.2	103	6.5	96.8	99	3.6	71.5	94	18.0	176.7	114	10.5	154.8	110	5.3	104.0	110	23.9	232.9	125	14.4	211.9	121	9.7	190.2	117	20.8	206.1	87	12.5	186.3	83	8.3	165.7	78	26.1	256.9	99	16.1	237.9	95	10.4	204.6	92	31.5	307.2	110	19.7	288.8	106	13.8	270.1	102	15.4	201.6	98	15.8	156.9	96	9.2	136.9	92	5.8	115.9	87	21.1	207.3	108	12.7	188.3	104	8.0	158.2	101	26.4	257.6	120	16.3	239.3	115	11.2	220.4	111	10.9	107.8	105	5.9	87.3	100	3.3	64.9	95	16.1	158.1	117	9.4	138.9	112	5.7	111.6	109	21.3	208.1	129	12.9	189.8	124	8.7	170.9	120	23.9	232.9	125	14.4	211.9	121	9.7	190.2	117	20.8	206.1	87	12.5	186.3	83	8.3	165.7	78	26.1	256.9	99	16.1	237.9	95	10.4	204.6	92	31.5	307.2	110	19.7	288.8	106	13.8	270.1	102	15.4	201.6	98	15.8	156.9	96	9.2	136.9	92	5.8	115.9	87	21.1	207.3	108	12.7	188.3	104	8.0	158.2	101	26.4	257.6	120	16.3	239.3	115	11.2	220.4	111	10.9	107.8	105	5.9	87.3	100	3.3	64.9	95	16.1	158.1	117	9.4	138.9	112	5.7	111.6	109	21.3	208.1	129	12.9	189.8	124	8.7	170.9	120	23.9	232.9	125	14.4	211.9	121	9.7	190.2	117	20.8	206.1	87	12.5	186.3	83	8.3	165.7	78	26.1	256.9	99	16.1	237.9	95	10.4	204.6	92	31.5	307.2	110	19.7	288.8	106	13.8	270.1	102	15.4	201.6	98	15.8	156.9	96	9.2	136.9	92	5.8	115.9	87	21.1	207.3	108	12.7	188.3	104	8.0	158.2	101	26.4	257.6	120	16.3	239.3	115	11.2	220.4	111	10.9	107.8	105	5.9	87.3	100	3.3	64.9	95	16.1	158.1	117	9.4	138.9	112	5.7	111.6	109	21.3	208.1	129	12.9	189.8	124	8.7	170.9	120	23.9	232.9	125	14.4	211.9	121	9.7	190.2	117	20.8	206.1	87	12.5	186.3	83	8.3	165.7	78	26.1	256.9	99	16.1	237.9	95	10.4	204.6	92	31.5	307.2	110	19.7	288.8	106	13.8	270.1	102	15.4	201.6	98	15.8	156.9	96	9.2	136.9	92	5.8	115.9	87	21.1	207.3	108	12.7	188.3	104	8.0	158.2	101	26.4	257.6	120	16.3	239.3	115	11.2	220.4	111	10.9	107.8	105	5.9	87.3	100	3.3	64.9	95	16.1	158.1	117	9.4	138.9	112	5.7	111.6	109	21.3	208.1	129	12.9	189.8	124	8.7	170.9	120	23.9	232.9	125	14.4	211.9	121	9.7	190.2	117	20.8	206.1	87	12.5	186.3	83	8.3	165.7	78	26.1	256.9	99	16.1	237.9	95	10.4	204.6	92	31.5	307.2	110	19.7	288.8	106	13.8	270.1	102	15.4	201.6	98	15.8	156.9	96	9.2	136.9	92	5.8	115.9	87	21.1	207.3	108	12.7	188.3	104	8.0	158.2	101	26.4	257.6	120	16.3	239.3	115	11.2	220.4	111	10.9	107.8	105	5.9	87.3	100	3.3	64.9	95	16.1	158.1	117	9.4	138.9	112	5.7	111.6	109	21.3	208.1	129	12.9	189.8	124	8.7	170.9	120	23.9	232.9	125	14.4	211.9	121	9.7	190.2	117	20.8	206.1	87	12.5	186.3	83	8.3	165.7	78	26.1	256.9	99	16.1	237.9	95	10.4	204.6	92	31.5	307.2	110	19.7	288.8

# HOT WATER COIL CAPACITIES - 072-150

Model No.	Air Flow (cfm)	Enter-ing Air Temp (°F)	200						210											
			20		30		40		20		30		40							
			GPM	LAT	GPM	LAT	GPM	LAT	GPM	LAT	GPM	LAT	GPM	LAT						
072	1920	40	22.4	217.0	144	14.3	207.6	139	10.2	197.9	135	24.0	231.9	151	15.4	222.6	146	11.0	213.1	142
		60	19.3	186.8	150	12.2	177.5	145	8.6	167.7	141	20.9	201.7	157	13.3	192.5	153	9.4	183.0	148
		80	16.2	156.9	156	10.1	147.6	152	7.1	137.7	147	17.8	171.8	163	11.2	162.6	159	7.9	152.9	154
072	2400	40	26.2	254.2	137	16.9	241.6	133	12.7	241.6	134	28.2	270.3	144	18.6	259.9	140	13.0	247.6	135
		60	22.6	218.8	144	14.2	207.3	140	10.2	194.7	137	24.5	236.3	151	15.6	224.8	147	11.5	214.5	146
		80	19.0	183.7	151	11.8	172.2	147	8.2	160.3	142	20.9	201.2	158	13.1	189.8	154	9.2	178.5	149
072	2880	40	29.7	288.0	132	18.9	274.5	127	13.4	260.6	123	31.9	308.1	138	20.3	294.8	134	14.5	281.0	129
		60	25.6	247.9	140	16.1	234.4	135	11.3	220.5	131	27.8	267.8	146	17.6	254.5	142	12.4	240.9	137
		80	21.5	208.0	147	13.4	194.5	143	9.3	180.6	138	23.6	227.9	154	14.8	214.6	149	10.4	200.9	145
090	2400	40	26.2	254.2	137	16.9	241.6	133	12.7	241.6	134	28.2	270.3	144	18.6	259.9	140	13.0	247.6	135
		60	22.6	218.8	144	14.2	207.3	140	10.2	194.7	137	24.5	236.3	151	15.6	224.8	147	11.5	214.5	146
		80	19.0	183.7	151	11.8	172.2	147	8.2	160.3	142	20.9	201.2	158	13.1	189.8	154	9.2	178.5	149
090	3000	40	30.6	296.0	131	19.4	282.1	126	13.8	267.6	122	32.8	316.7	137	20.9	302.7	133	14.9	288.6	128
		60	26.3	254.8	139	16.5	240.8	134	11.6	226.5	130	28.5	275.3	145	18.0	261.5	141	12.8	247.4	136
		80	22.1	213.8	146	13.7	199.9	142	9.5	185.4	138	24.3	234.3	153	15.2	220.5	149	10.7	206.3	144
120	3600	40	34.5	334.0	125	21.8	317.5	121	15.5	301.0	117	37.1	357.3	131	23.5	341.1	127	16.8	324.8	123
		60	29.7	287.4	134	18.6	271.0	130	13.1	254.5	125	32.2	310.6	140	20.3	294.5	136	14.4	278.2	131
		80	24.9	241.0	142	15.4	224.8	138	10.7	208.1	134	27.4	264.2	148	17.1	248.1	144	12.0	231.8	140
120	3200	40	31.9	309.1	129	20.2	294.2	124	14.3	279.1	120	34.3	330.6	135	21.8	316.0	131	15.5	301.0	126
		60	27.5	266.1	137	17.3	251.2	133	12.1	236.1	128	29.8	287.6	143	18.8	272.8	139	13.3	258.1	135
		80	23.0	223.2	145	14.3	208.5	141	9.9	193.2	136	25.4	244.6	151	15.9	230.0	147	11.1	215.1	143
150	4000	40	36.9	357.4	122	23.3	339.7	118	16.5	321.5	114	39.7	382.6	128	25.2	364.8	124	17.9	346.9	120
		60	31.7	307.5	131	19.9	289.7	127	14.0	271.6	123	34.5	332.4	137	21.7	315.1	133	15.3	297.1	129
		80	26.6	258.0	140	16.5	240.2	136	11.4	222.0	132	29.3	282.8	146	18.3	265.2	142	12.8	247.4	138
150	4800	40	41.4	400.8	117	26.1	380.0	113	18.5	359.3	109	44.5	428.8	122	28.2	408.4	118	20.0	387.9	114
		60	35.6	344.7	126	22.3	324.2	122	15.6	303.4	118	38.7	372.8	132	24.3	352.4	128	17.1	331.9	124
		80	29.8	288.9	136	18.5	268.6	132	12.7	247.8	128	32.9	316.9	142	20.5	296.9	138	14.3	276.2	134
150	4000	40	36.9	357.4	122	23.3	339.7	118	16.5	321.5	114	39.7	382.6	128	25.2	364.8	124	17.9	346.9	120
		60	31.7	307.5	131	19.9	289.7	127	14.0	271.6	123	34.5	332.4	137	21.7	315.1	133	15.3	297.1	129
		80	26.6	258.0	140	16.5	240.2	136	11.4	222.0	132	29.3	282.8	146	18.3	265.2	142	12.8	247.4	138
150	5000	40	42.4	411.0	115	26.8	389.5	111	18.9	368.2	108	45.6	439.7	121	28.9	418.7	117	20.5	397.5	113
		60	36.5	353.4	125	22.8	332.2	121	16.0	311.0	118	39.6	382.2	131	24.9	361.2	127	17.6	340.1	123
		80	30.6	296.3	135	18.9	275.3	131	13.1	253.9	127	33.7	325.0	141	21.0	304.1	137	14.6	283.0	133
150	6000	40	47.3	458.4	110	29.8	434.0	106	21.1	409.5	103	50.9	490.7	115	32.2	466.5	111	22.8	442.4	108
		60	40.7	394.2	121	25.4	370.1	117	17.8	345.5	113	44.2	426.5	126	27.8	402.5	122	19.5	378.3	118
		80	34.1	330.4	131	21.0	306.3	128	14.5	281.7	124	37.6	362.4	136	23.4	338.6	133	16.2	314.5	129

# HOT WATER COIL CAPACITIES - 180-240

Model No.	Air Flow (cfm)	Enter- ing Air Temp (°F)	Entering Water Temperature (°F)																										
			140				160				180																		
			20			30			40			20			30			40											
Water Temperature Drop (°F)			30			40			20			30			40														
			GPM	LAT	MBh	GPM	LAT	MBh	GPM	LAT	MBh	GPM	LAT	MBh	GPM	LAT	MBh	GPM	LAT	MBh	GPM	LAT	MBh	GPM	LAT	MBh	GPM	LAT	MBh
180	4800	40	27.8	275.7	93	17.1	253.8	88	11.6	230.7	84	34.6	340.8	105	21.6	319.9	101	15.1	298.2	97	41.6	405.9	118	26.3	385.7	114	18.6	364.9	110
		60	21.4	211.5	101	12.7	189.3	96	8.3	165.2	92	28.1	276.4	113	17.3	255.3	109	11.8	233.1	105	34.9	341.1	126	21.9	320.9	122	15.3	299.9	118
		80	14.9	147.5	109	8.4	124.2	104	4.9	97.8	99	21.6	212.4	121	12.9	191.0	117	8.5	167.7	113	28.3	276.8	134	17.5	256.5	130	12.0	235.0	126
180	6000	40	32.1	318.2	89	19.6	292.0	85	13.3	264.7	80	40.0	394.0	100	24.9	368.7	96	17.4	342.7	92	48.0	469.1	112	30.3	445.0	108	21.4	419.9	104
		60	24.6	243.8	98	14.6	217.4	94	9.5	188.9	89	32.4	319.2	109	19.9	293.9	105	13.6	267.6	101	40.4	394.4	121	25.2	370.0	117	17.6	345.0	113
		80	17.1	169.7	106	9.6	142.0	102	5.6	111.0	97	24.9	244.9	118	14.8	219.4	114	9.7	191.9	110	32.7	319.8	130	20.1	295.6	126	13.8	269.8	122
180	7200	40	36.0	356.1	85	21.9	326.2	82	14.8	294.8	78	44.8	441.1	96	27.9	412.3	93	19.4	382.4	89	53.8	525.9	107	33.9	497.9	103	23.9	469.3	100
		60	27.5	272.6	95	16.3	242.2	91	10.6	209.9	87	36.3	357.3	106	22.2	328.5	102	15.1	298.2	98	45.2	441.8	117	28.2	414.0	113	19.6	385.2	109
		80	19.1	189.4	105	10.6	157.9	100	6.2	122.7	96	27.9	274.2	116	16.6	244.8	112	10.8	213.3	108	36.7	358.2	126	22.5	330.2	123	15.3	300.8	119
180	6400	40	33.4	331.2	87	20.4	303.9	84	13.9	275.1	79	41.7	410.1	99	26.0	383.9	95	18.1	356.5	91	50.0	488.7	110	31.6	463.1	106	22.3	437.0	103
		60	25.6	253.7	97	15.2	226.0	93	9.9	196.3	88	33.8	332.3	108	20.7	306.0	104	14.1	278.2	100	42.0	410.6	119	26.3	385.3	116	18.3	358.8	112
		80	17.8	176.4	106	9.9	147.6	102	5.8	115.0	97	25.9	254.9	117	15.4	228.2	113	10.1	199.4	109	34.1	333.0	129	21.0	307.5	125	14.3	280.5	121
240	8000	40	38.3	379.4	84	23.3	347.0	80	15.8	313.2	76	47.8	470.4	94	29.7	439.0	90	20.6	406.9	87	57.4	560.8	104	36.1	530.5	101	25.5	499.5	97
		60	29.3	290.3	94	17.3	257.6	90	11.2	222.6	86	38.7	380.9	104	23.6	349.6	100	16.1	317.0	97	48.2	471.0	114	30.0	440.6	111	20.9	409.7	107
		80	20.3	201.4	103	11.3	167.6	100	6.5	129.8	95	29.7	291.8	114	17.6	260.2	110	11.5	226.5	106	39.1	381.9	125	23.9	351.5	121	16.3	319.9	117
240	9600	40	42.6	422.1	80	25.9	385.2	77	17.5	346.7	73	53.2	523.6	90	33.0	488.0	87	22.9	451.3	83	64.0	624.7	100	40.2	590.2	96	28.3	554.8	93
		60	32.6	322.8	91	19.2	285.3	87	12.4	246.0	84	43.1	423.9	101	26.3	388.2	97	17.8	351.1	94	53.7	524.7	111	33.4	490.2	107	23.2	454.7	104
		80	22.6	223.5	102	12.5	185.2	98	7.2	142.6	94	33.0	324.5	112	19.5	288.5	108	12.7	250.3	104	43.5	425.1	121	26.6	390.5	118	18.1	354.5	114

## HOT WATER COIL CAPACITIES - 180-240

Model No.	Air Flow (cfm)	Entering Air Temp (°F)	200						210											
			20		30		40		20		30		40							
			GPM	LAT	GPM	MBh	LAT	MBh	GPM	MBh	LAT	MBh	GPM	MBh	LAT	MBh				
180	4800	40	48.6	470.3	130	31.0	450.7	126	22.4	428.6	123	52.1	502.7	136	33.3	483.3	132	24.0	460.6	128
		60	41.9	405.6	138	26.5	386.0	134	18.8	365.8	130	45.4	437.5	144	28.8	418.2	141	20.6	397.6	137
		80	35.2	341.0	146	22.1	321.4	142	15.5	301.0	138	38.7	373.1	152	24.4	353.8	149	17.2	333.7	145
	6000	40	56.2	544.1	123	35.8	520.5	120	25.5	496.6	116	60.3	581.5	129	38.5	558.2	125	27.6	534.5	122
	60	48.4	469.0	132	30.6	445.6	129	21.7	421.3	125	52.5	506.3	138	33.3	483.1	134	23.7	459.2	131	
	80	40.7	394.5	141	25.5	370.8	138	17.8	346.5	134	44.8	431.6	147	28.2	408.2	143	19.8	384.4	140	
240	7200	40	63.0	610.3	118	40.0	583.0	114	28.5	555.3	111	67.6	652.0	123	43.1	625.4	120	30.9	598.1	116
		60	54.3	525.9	128	34.3	498.7	124	24.2	471.0	120	58.9	568.0	133	37.3	541.0	129	26.5	513.7	126
		80	45.6	442.1	137	28.5	415.1	134	19.9	387.0	130	50.2	484.0	143	31.5	457.1	139	22.2	429.7	136
	6400	40	58.5	566.9	121	37.2	542.1	118	26.6	516.9	114	62.8	605.9	127	40.1	581.3	123	28.7	556.4	120
	60	50.4	488.7	131	31.9	464.0	127	22.5	438.5	123	54.7	527.5	136	34.7	503.1	133	24.7	478.0	129	
	80	42.4	410.8	140	26.5	386.1	136	18.5	360.4	133	46.6	449.7	146	29.3	425.1	142	20.7	400.1	138	
8000	40	67.2	651.0	115	42.7	621.4	111	30.4	591.4	108	72.2	695.9	120	46.0	666.7	116	32.9	637.1	113	
60	57.9	561.0	125	36.5	531.6	121	25.8	501.4	118	62.8	605.8	130	39.8	576.7	127	28.2	547.0	123		
80	48.7	471.4	135	30.4	442.0	132	21.2	411.7	128	53.5	516.2	140	33.6	487.2	137	23.6	457.3	133		
9600	40	73.9	720.7	108	47.5	691.7	106	33.8	657.5	103	78.0	762.4	112	51.2	742.0	111	36.6	708.6	108	
	60	64.5	625.1	120	40.6	591.5	117	28.6	557.2	114	70.0	675.2	125	44.3	641.9	122	31.4	608.2	119	
	80	54.2	525.2	131	33.8	491.6	128	23.5	457.2	124	59.6	575.2	136	37.4	542.0	133	26.2	508.0	129	

**WEIGHT DATA**

Model Number	Net		Shipping	
	lbs.	kg	lbs.	kg
072	330	150	380	172
090	350	159	400	181
120	435	197	495	225
150	455	206	515	234
180	680	308	760	345
240	720	327	800	363

**OPTIONS / ACCESSORIES**

	Net		Shipping	
	lbs.	kg	lbs.	kg

**MSAV® (MULTI-STAGE AIR VOLUME) SUPPLY AIR BLOWER VFD KITMSAV® (MULTI-STAGE AIR VOLUME) SUPPLY AIR BLOWER VFD KIT**

	T2MSAV20LM1Y	3	2	23	11
	T2MSAV20LM1G	3	2	23	11
	T2MSAV20LM1J	5	3	24	11
	T2MSAV20LN1Y	3	2	23	11
	T2MSAV20LN1G	4	2	23	11
	T2MSAV20LN1J	5	3	24	11
	T2MSAV20MN1Y	4	2	24	11
	T2MSAV20MN1G	4	2	23	11
	T2MSAV20MN1J	9	5	28	13
	T2MSAV20N-1Y	8	4	28	13
	T2MSAV20N-1G	8	4	27	13
	T2MSAV20N-1J	8	4	28	13

**ELECTRIC HEAT**

072-150	10 kW	65	29	75	34
	15 kW	65	29	75	34
	25 kW	65	29	75	34
	35 kW	65	29	75	34
180-240	20 kW	100	45	120	54
	30 kW	100	45	120	54
	40 kW	100	45	120	54
	50 kW	100	45	120	54

**ECONOMIZER**

Standard Economizers	T2ECON31L-1-	71	32	165	75
	T2ECON31M-1-	114	52	265	120
	T2ECON31N-1-	160	73	370	168
High Performance Economizers	T2ECON34L-1	108	49	202	92
	T2ECON34M-1	144	65	295	134
	T2ECON34N-1	188	85	398	181

**5 INCH FILTER MOUNTING KIT**

	T2FLTR70L-1-	7	3	10	5
	T2FLTR70M-1-	10	5	14	6
	T2FLTR70N-1-	15	7	20	9

**HOT WATER COIL**

	T2HWCL10LM1-	65	29	80	36
	T2HWCL10N-1-	80	36	100	45

**RETURN AIR GRILLE**

	T2GARD30L-1	4	2	20	9
	T2GARD30M-1	5	2	30	14
	T2GARD30N-1	6	3	35	16

**UVC LIGHT KITS**

	T2UVCL10LM1Y	17	8	20	9
	T2UVCL10N-1Y	23	10	26	12

# DIMENSIONS - INCHES (MM) - TAA072 AND TAA090

## UPFLOW POSITION SHOWN

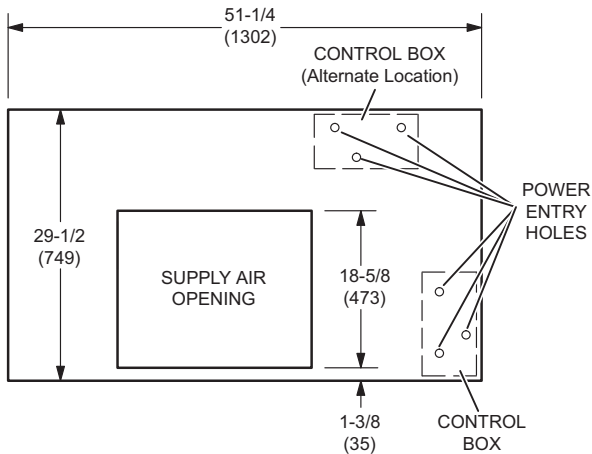

**SUPPLY END VIEW**

**NOTE:**  
072 models only use one Suction and Liquid Line. Cabinet has knockouts for two. Either opening may be used.

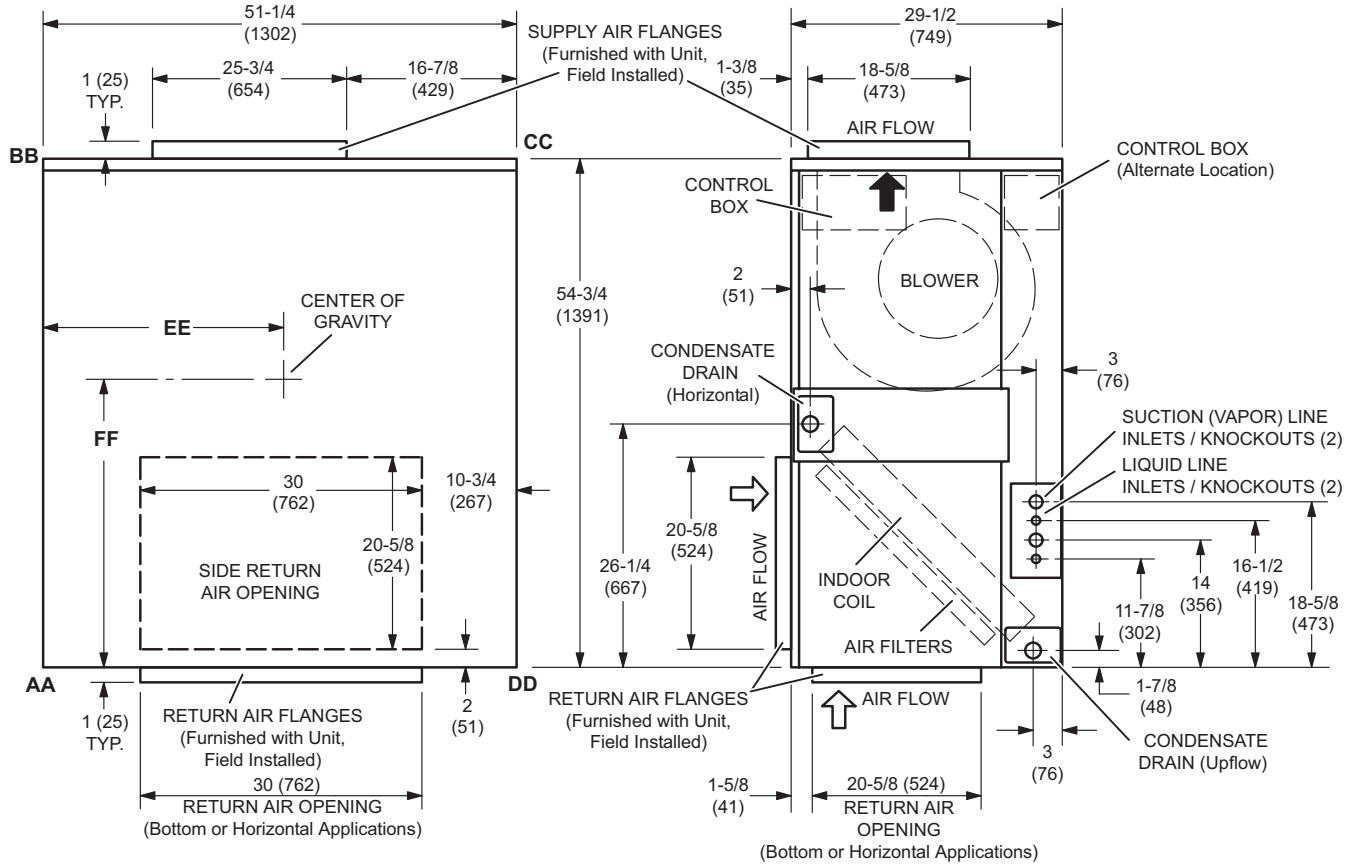

**INLET VIEW**

**DRIVE END VIEW**

Model No.	CORNER WEIGHTS								CENTER OF GRAVITY			
	AA		BB		CC		DD		EE		FF	
	lbs.	kg	lbs.	kg	lbs.	kg	lbs.	kg	in.	mm	in.	mm
TAA072	88	40	88	40	88	40	88	40	25-1/2	648	25-1/2	648
TAA090	88	40	88	40	88	40	88	40	25-1/2	648	25-1/2	648

# DIMENSIONS - INCHES (MM) - TAA120 AND TAA150

UPFLOW POSITION SHOWN

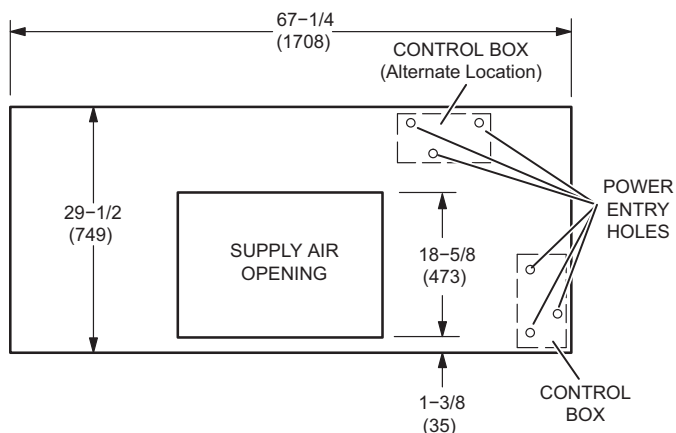

SUPPLY END VIEW

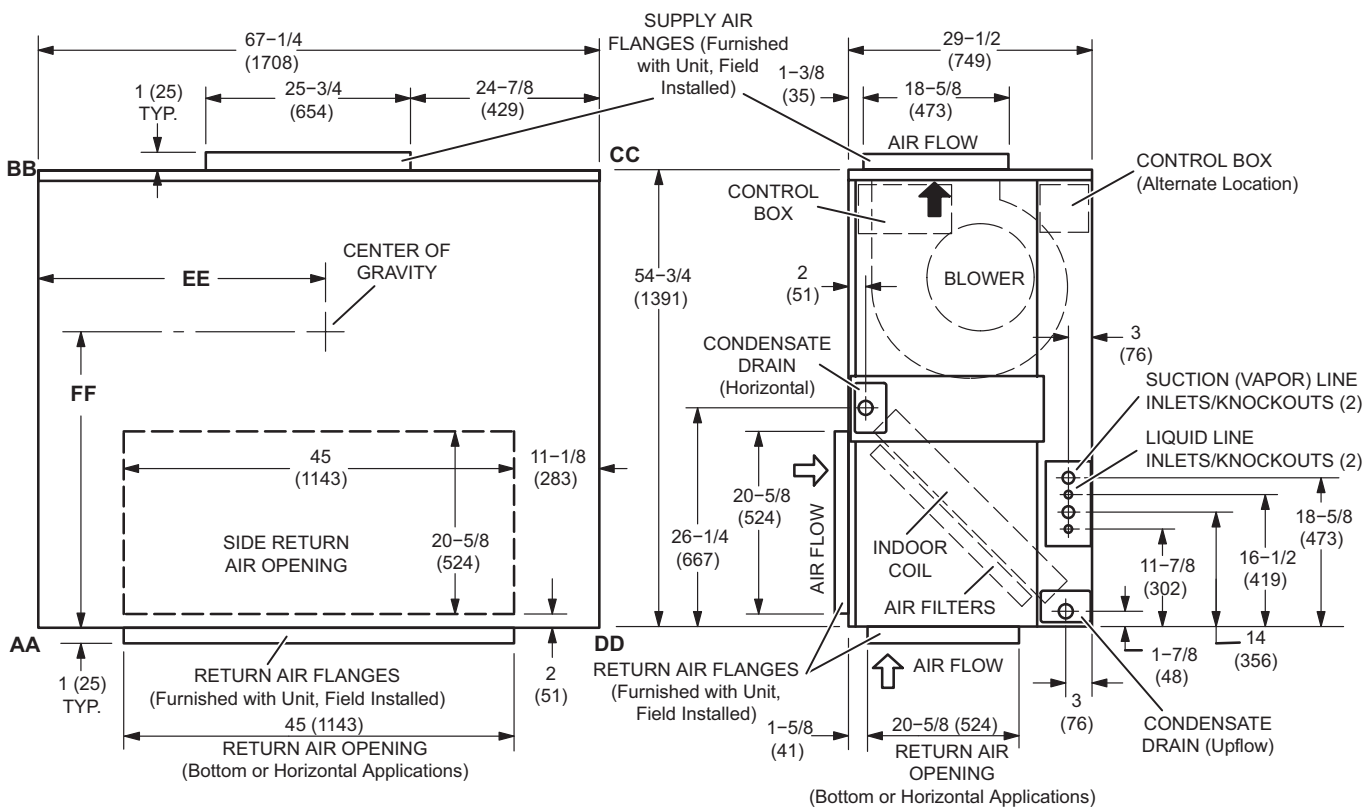

INLET VIEW

DRIVE END VIEW

CORNER WEIGHTS				CENTER OF GRAVITY			
AA	BB	CC	DD	EE		FF	
lbs.	kg	lbs.	kg	in.	mm	in.	mm
126	57	101	46	101	46	33-1/2	851
				24-1/2	622		



**DIMENSIONS - INCHES (MM) - TAA180 AND TAA240**

**UPFLOW POSITION SHOWN**

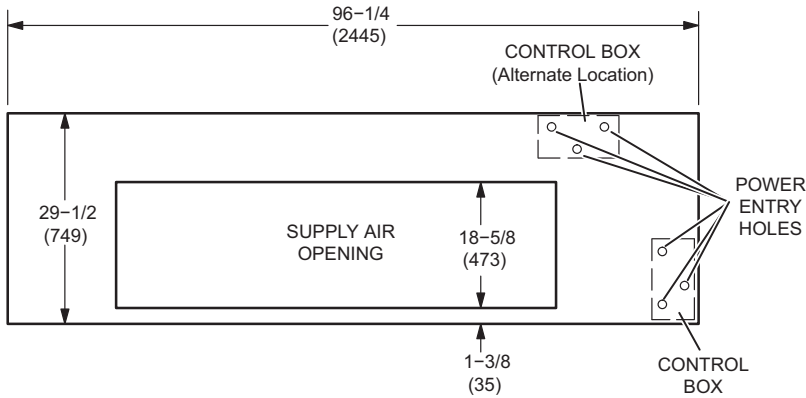

**SUPPLY END VIEW**

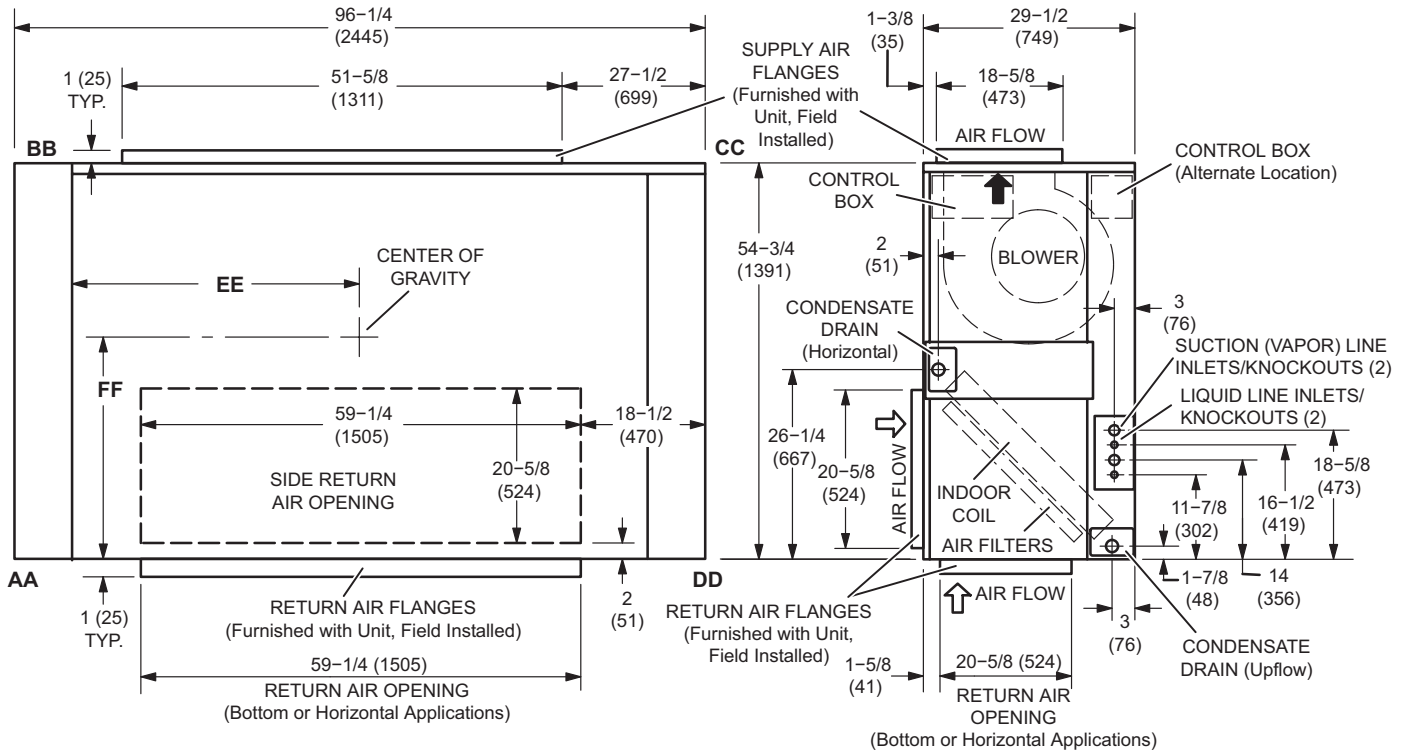

**INLET VIEW**

**DRIVE END VIEW**

CORNER WEIGHTS				CENTER OF GRAVITY			
AA	BB	CC	DD	EE		FF	
lbs. kg	lbs. kg	lbs. kg	lbs. kg	in. mm	in. mm	in. mm	in. mm
110 50	99 45	116 53	130 59	52 1321	25-3/4 654		

**TYPICAL SUPPORT METHOD FOR AIR HANDLER WITH HEAT SECTION IN HORIZONTAL POSITION**

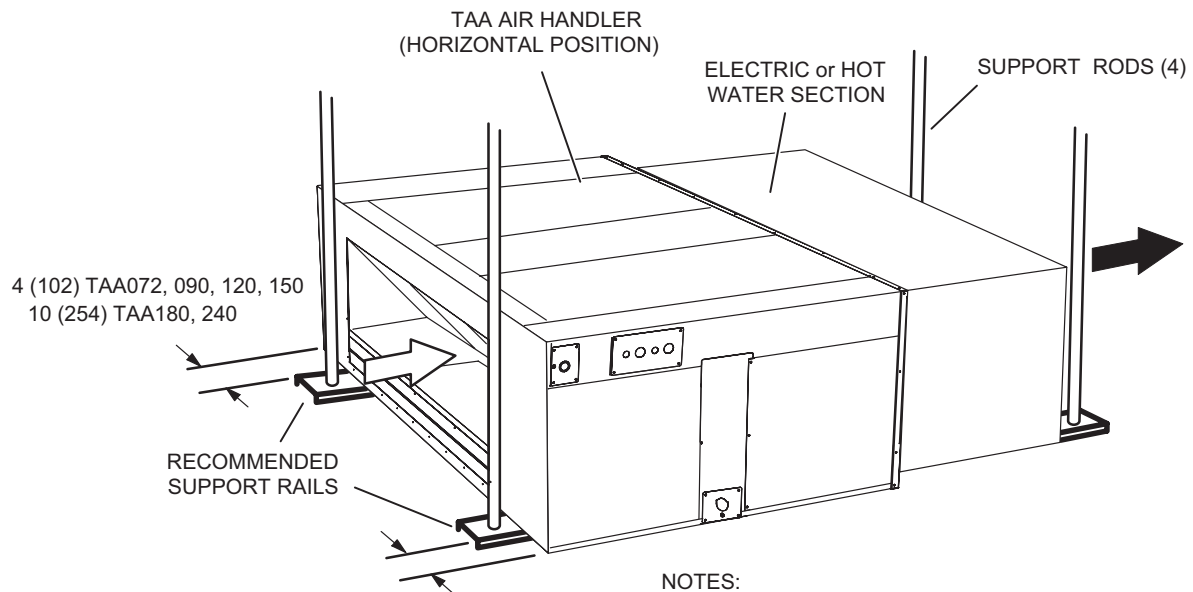

**NOTES:**

- 4 (102) TAA072, 090, 120, 150  
10 (254) TAA180, 240
1. Ensure support rails do not interfere with ducting, plumbing or electrical connections.
  2. When hot water or electric heat section is installed, additional support underneath these accessories will be required.
  3. Support rods and rails are field supplied.

**ACCESSORY DIMENSIONS - INCHES (MM) - ELECTRIC HEAT**

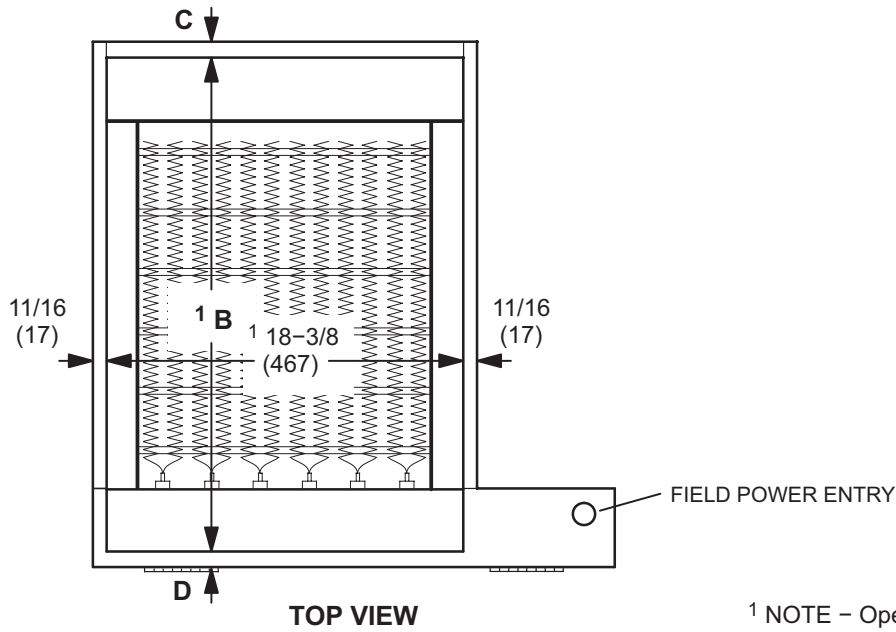

<sup>1</sup> NOTE - Openings same size top and bottom.

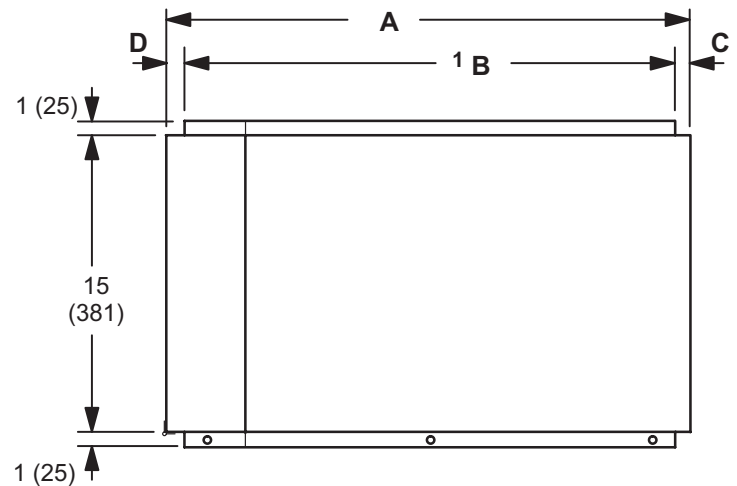
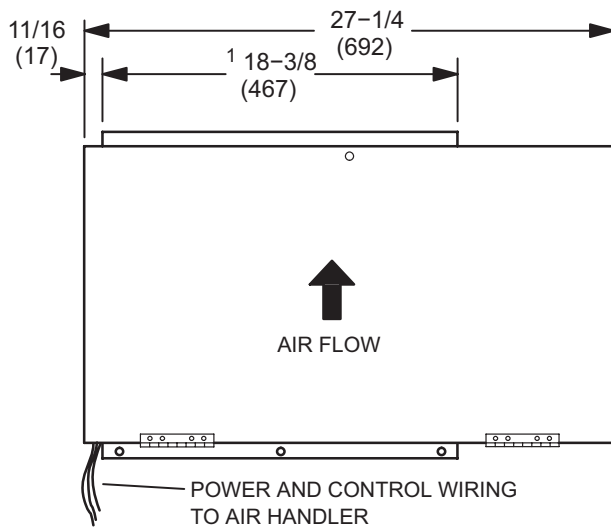

Air Handler Usage	A		B		C		D	
	in.	mm	in.	mm	in.	mm	in.	mm
TAA072 Thru TAA150	27-1/8	689	25-1/2	648	13/16	21	13/16	21
TAA180 Thru TAA240	56-3/4	1441	51-1/4	1302	1-1/2	38	4	102

**ACCESSORY DIMENSIONS - INCHES (MM) - HOT WATER COIL**

<sup>1</sup> NOTE - Openings same size top and bottom.

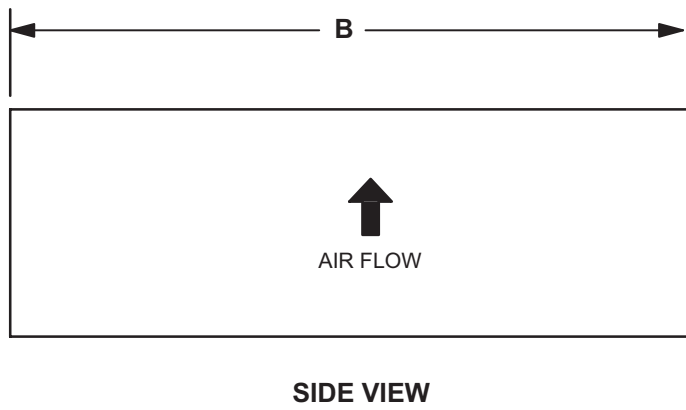
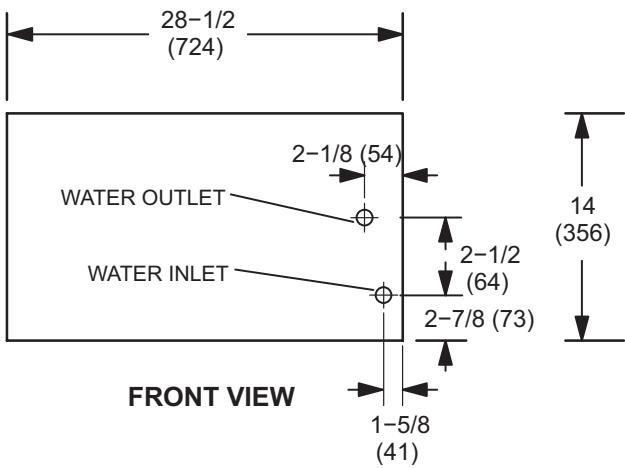
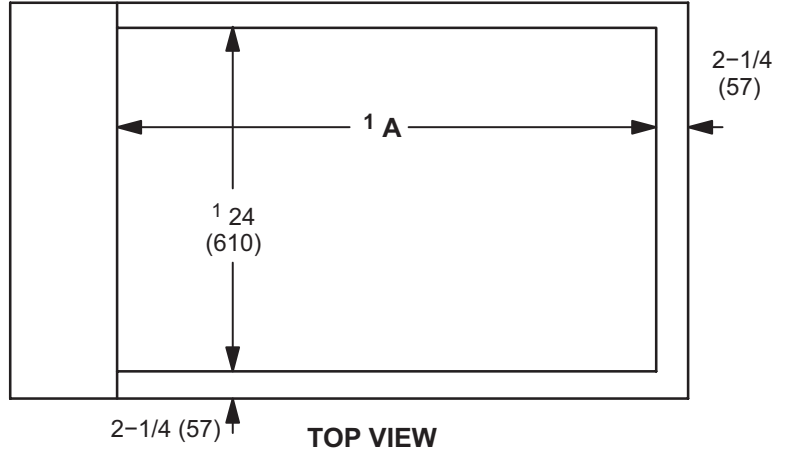

Air Handler Usage	A		B	
	in.	mm	in.	mm
TAA072 Thru TAA150	36	914	48	1219
TAA180 Thru TAA240	54	1372	66	1676

## ACCESSORY DIMENSIONS - INCHES (MM) - ECONOMIZER

NOTE- Economizer section may be rotated 180° for bottom return air connection.

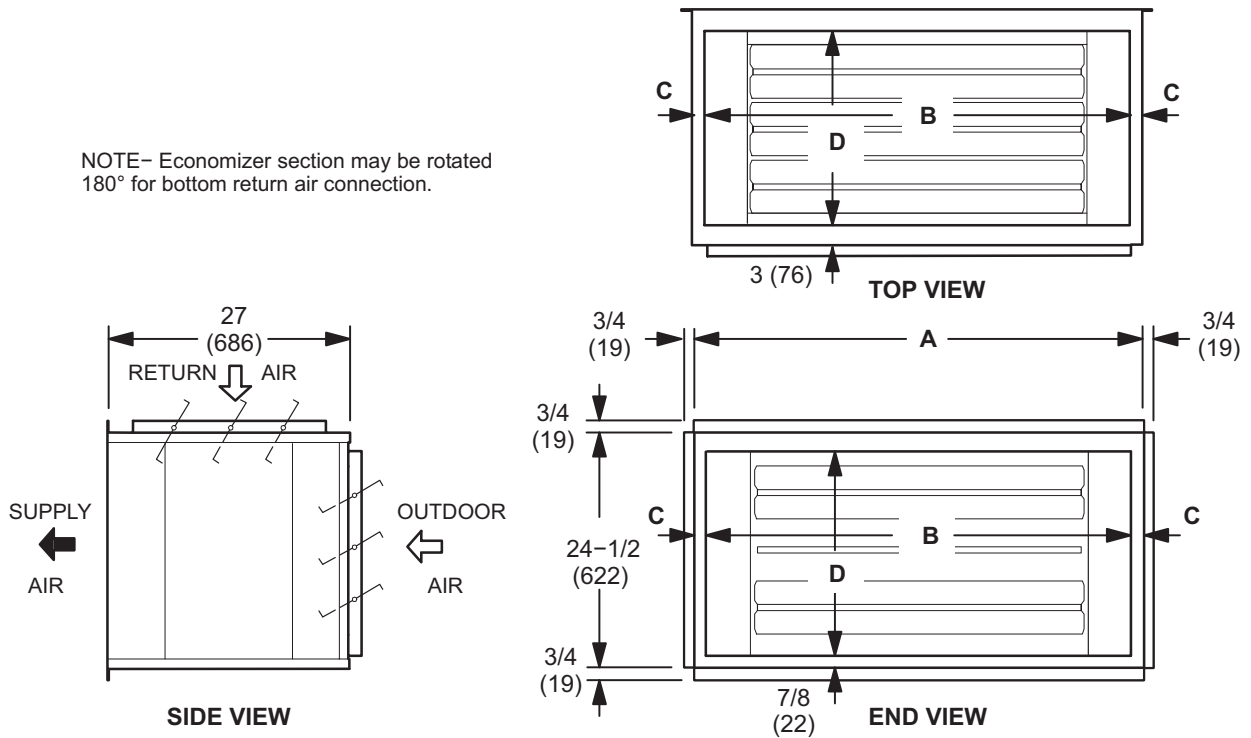

Model No. (Air Handler Usage)		A		B		C		D	
		in.	mm	in.	mm	in.	mm	in.	mm
Standard Economizers	T2ECON31L-1- (072-090)	32	813	30	762	1	25	20-1/2	521
	T2ECON31M-1- (120-150)	51-1/2	1308	45	1143	3-1/4	83	20-1/2	521
	T2ECON31N-1- (180-240)	72	1829	60	1524	6	152	20-1/2	521
High Performance Economizers	T2ECON34L-1 (072-090)	32	813	30	762	1	25	20-1/4	514
	T2ECON34M-1 (120-150)	51-1/2	1308	45	1143	3-1/4	83	20-1/4	514
	T2ECON34N-1 (180-240)	72	1829	60	1524	6	152	20-1/4	514

## ACCESSORY DIMENSIONS - INCHES (MM) - MSAV® VFD KIT

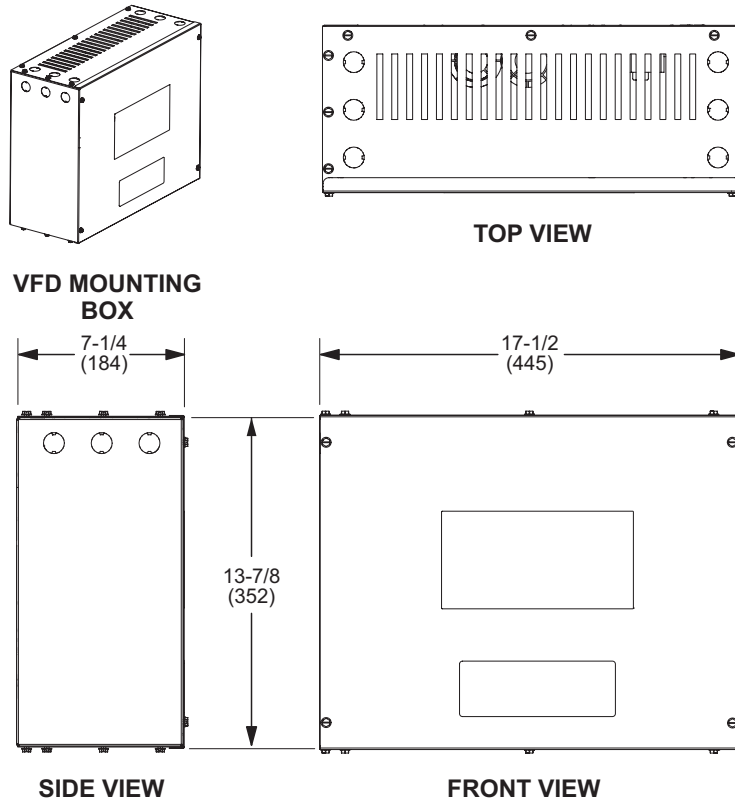

**ACCESSORY DIMENSIONS - INCHES (MM)**

**AIR HANDLER WITH OPTIONAL ELECTRIC HEAT/HOT WATER COIL AND ECONOMIZER**

**UPFLOW**

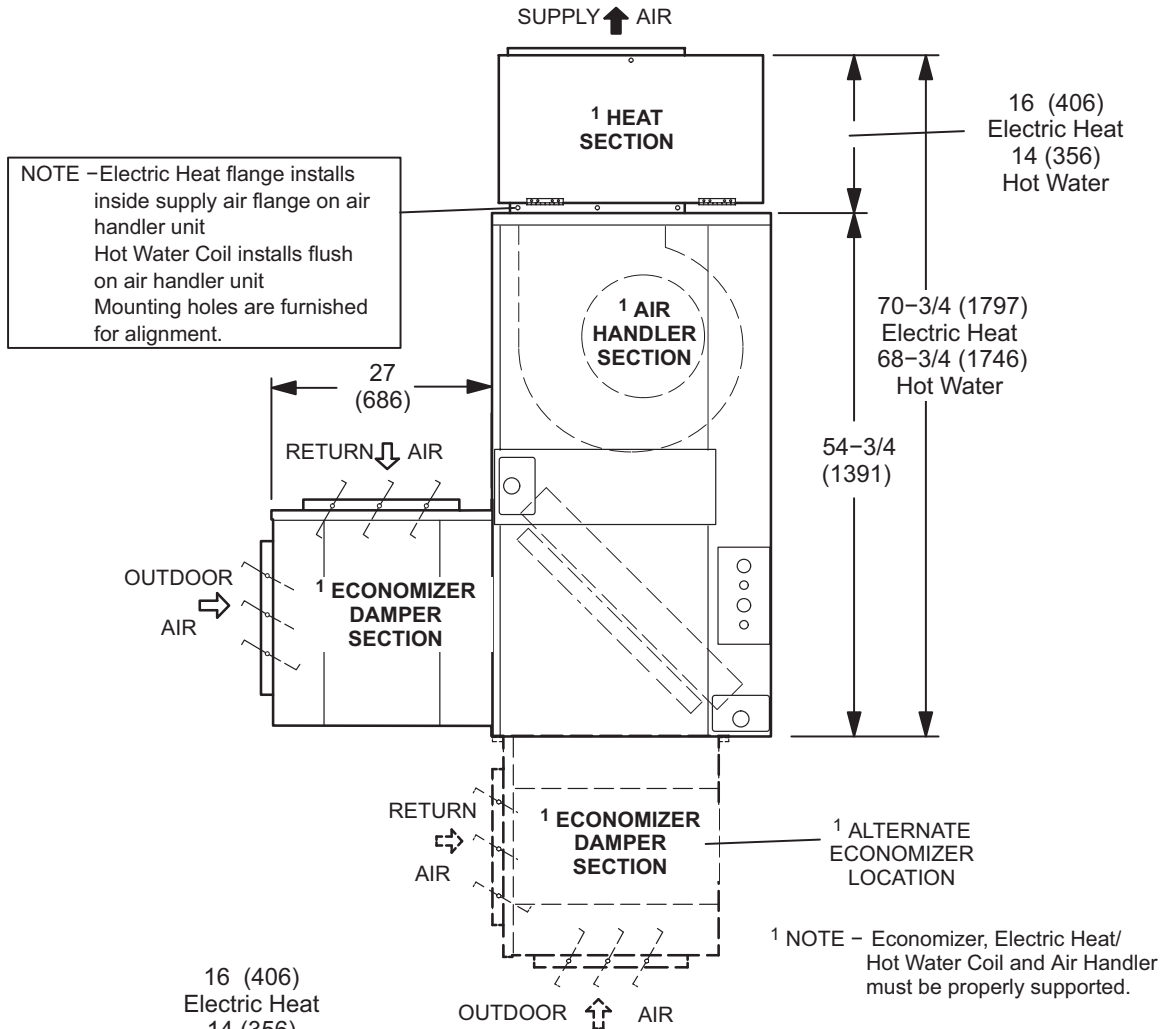

**HORIZONTAL**

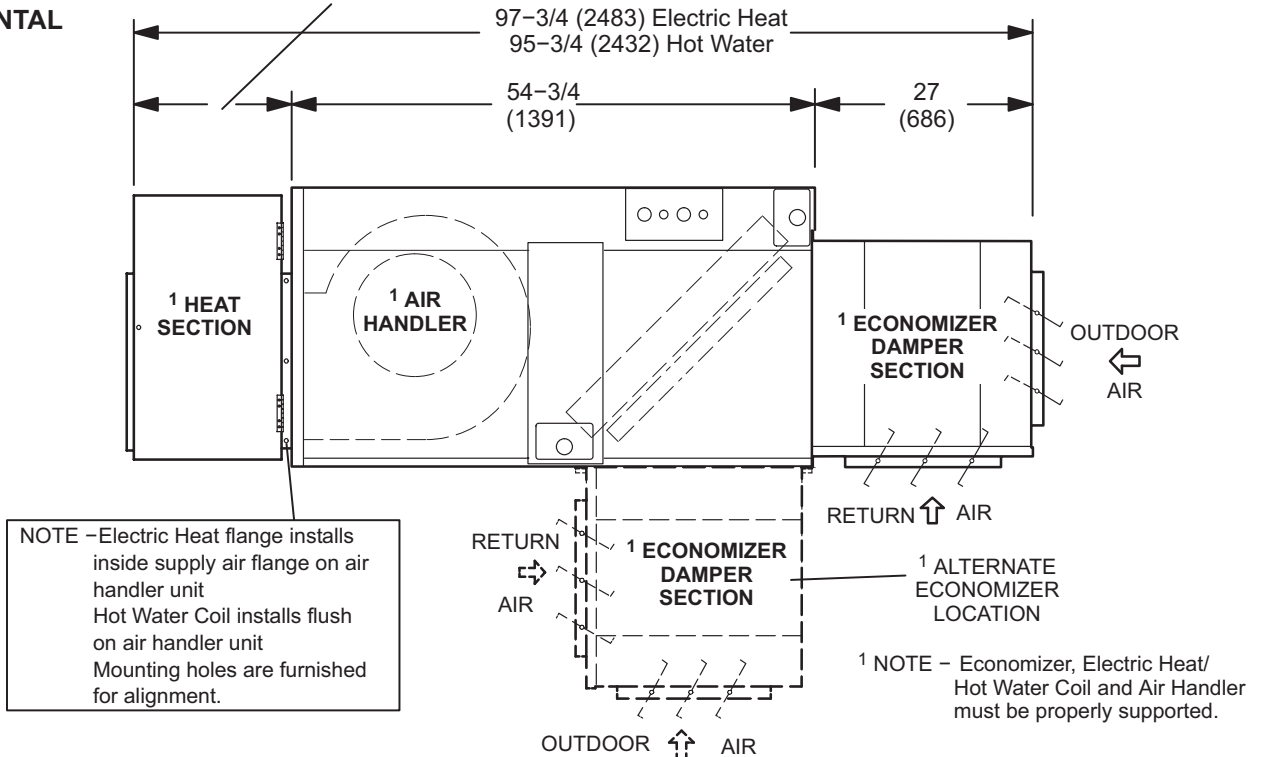



## REVISIONS

Sections	Description of Change
Optional Accessories	Updated catalog numbers for Enthalpy Controls.



**Intertek**



Visit us at [www.lennox.com](http://www.lennox.com)

For the latest technical information, [www.lennoxcommercial.com](http://www.lennoxcommercial.com)

Contact us at 1-800-4-LENNOX

NOTE - Due to Lennox' ongoing commitment to quality, Specifications, Ratings and Dimensions subject to change without notice and without incurring liability. Improper installation, adjustment, alteration, service or maintenance can cause property damage or personal injury. Installation and service must be performed by a qualified installer and servicing agency.

©2017 Lennox Industries, Inc.