



ENGINEERING DATA

TC
T-CLASS™ ROOFTOP UNITS
60 HZ

Bulletin No. 210416
 July 2008
 Supersedes August 2007



ASHRAE 90.1
 COMPLIANT



15 to 25 Tons
Net Cooling Capacity - 180,000 to 286,000 Btuh
Optional Electric Heat - 15 to 90 kW

MODEL NUMBER IDENTIFICATION

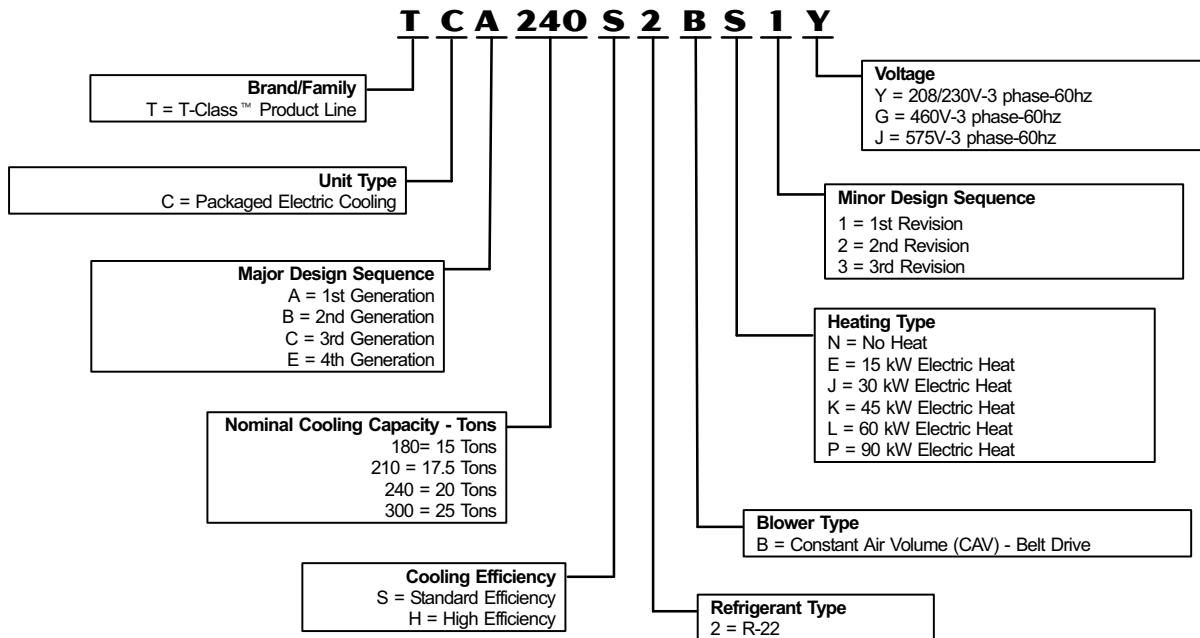

TABLE OF CONTENTS

Blower Data	Pages 15-20
Cooling Ratings	Pages 11-14
Dimensions	Pages 30-36
Electric Heat Capacities	Page 21
Electrical/ Electric Heat Data	Pages 21-27
Features and Benefits	Pages 2-4
Guide Specifications	Pages 37-43
Installation Clearances	Page 20
Model Number Identification	Page 1
Options / Accessories	Pages 5-8
Specifications	Pages 9-10
Sound Data	Page 20
Temperature Control Systems	Page 28
Weight Data	Page 29

FEATURES AND BENEFITS

APPROVALS

ETL and CSA listed.

Components bonded for grounding to meet safety standards for servicing required by UL, CSA and National and Canadian Electrical Codes.

180 thru 240 models are certified in accordance with the ULE certification program, which is based on ARI Standard 340/360-2000.

300S models are tested at conditions included in ARI Standard 340/360-2000. ENERGY STAR® certified units are designed to use less energy, help save money on utility bills, and help protect the environment.

The ENERGY STAR® Partner of the Year Award signifies that Lennox has made outstanding contributions to design energy efficient units that will lower energy bills, while meeting industry standards for comfort and indoor air quality. Lennox was the first HVAC manufacturer to win this award and has been a four-time recipient since 2003. ISO 9001 Registered Manufacturing Quality System.

WARRANTY

Limited five years on compressors.

Limited one year all other covered components.

COOLING SYSTEM

Designed to maximize sensible and latent cooling performance at design conditions.

Two efficiency levels provide flexibility. System can operate from 30°F to 125°F without any additional controls.

1 Compressors

Resiliently mounted on rubber grommets for quiet operation. Scroll compressors on all models for high performance, reliability and quiet operation.

2 Thermal Expansion Valves

Assures optimal performance throughout the application range. Removable element head.

3 Filter/Driers

High capacity filter/driers protect the system from dirt and moisture.

Freezestats

Protects the evaporator coil from damaging ice build-up due to conditions such as low/no air flow, or low/no refrigerant charge.

4 Coil Construction

Copper tube construction, enhanced rippled-edge aluminum fins, flared shoulder tubing connections, silver soldered construction for improved heat transfer. Factory leak tested.

Evaporator Coil

Cross row circuiting with rifled copper tubing optimizes both sensible and latent cooling capacity. Low fin per inch count minimizes air pressure drop. Face-split evaporator coils are designed to keep condensate water off of an inactive part of the coil so the condensate will not re-enter the air stream.

Condenser Coil

Formed type coil.

Condensate Drain Pan

Painted, galvanized pan with positive slope. Drain connection extends outside unit.

5 Outdoor Coil Fan Motors

Thermal overload protected, totally enclosed, permanently lubricated ball bearings, shaft up, independent motor mount.

Outdoor Coil Fan

PVC coated fan guard furnished.

REQUIRED SELECTIONS

Cooling Capacity

Specify the nominal cooling capacity of the unit.

Cooling Efficiency

Specify either standard or high efficiency.

OPTIONS/ACCESSORIES

Field Installed

Compressor Crankcase Heaters

Protects against refrigerant migration that can occur during low ambient operation.

Condensate Drain Trap

Available in copper or PVC.

High Pressure Switches

Protects the compressor from overload conditions such as dirty condenser coils, blocked refrigerant flow, or loss of outdoor fan operation. Manual reset.

Low Ambient Kit

Cycles the outdoor fan while allowing compressor operation in the cooling cycle. This intermittent fan operation allows the system to operate without icing the evaporator coil and losing capacity. Designed for use in ambient temperatures no lower than 0°F.

6 BLOWER

Supply air fan provides a wide range of air flow capability. Stocked models (units typically in-stock at warehouses) are equipped with standard static motor/drive combinations. Special order high and low static motor and drive options are available CTO (configure to order) offering an even wider range of capability.

Supply Air Motor

Overload protected with permanently lubricated ball bearings ensures durable operation. Belt drive motors that meet EPACT efficiency requirements maximize air performance and save energy. Special order high and low static motors provide a higher level of air performance for demanding applications.

Supply Air Blower

A double inlet wheel with forward curve blades provide maximum air performance and quiet operation. Dynamically balanced with permanently lubricated ball bearings assure long, reliable operation. Adjustable pulleys allow air to be precisely tuned to the needs of the application.

REQUIRED SELECTIONS

Supply Air Blower

Specify Blower motor / Drive Kit (See Blower Data Tables for specifications).

FEATURES AND BENEFITS

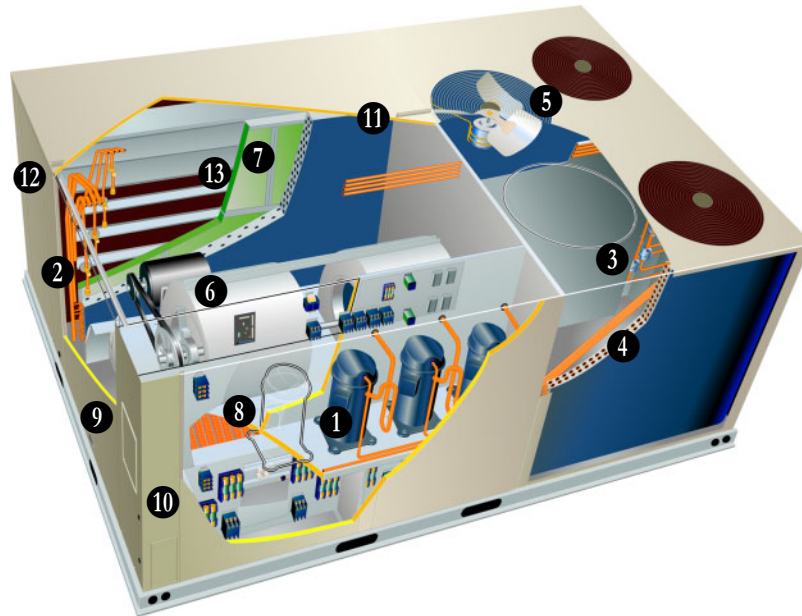

CONTROLS

Unit Controller

Microprocessor-based control board provides flexible control of cooling functions. All control voltage is provided via a 24V (secondary) transformer with built-in circuit breaker protection. Built-in functions include:

Blower On/Off Delay - Time delay between blower on and off cycles provides a more even supply air temperature during heating.

Built-in Control Parameters - Saves installation time as no programming is required.

Minimum Compressor Run Time - Ensures proper oil return to the compressor.

Night Setback Mode - Saves energy by closing outdoor air dampers and operating supply fan on thermostat demand only.

Heat/Cool Staging - Capable of up to 2 heat / 2 cool staging with a third party DDC control system or compatible thermostat.

Thermostat Bounce Delay - Protects compressor from short cycling when a mechanical thermostat is used.

OPTIONS/ACCESSORIES

Field Installed

Blower Proving Switch

Uses a static pressure sensor to monitor blower operation and shuts down unit if blower fails.

Dirty Filter Switch

Senses static pressure increase indicating dirty filter condition.

Smoke Detector

Photoelectric type, installed in supply air section or return air section or both sections

Commercial Control Systems

L Connection® Network

Complete building automation control system for single or multi-zone applications. Options include local interface, software for local or remote communication, and hardware for networking other control functions. See L Connection Network Engineering Handbook Bulletin for details.

Thermostats

Control system and thermostat options. Aftermarket unit controller options. See See Page 28.

INDOOR AIR QUALITY

7 Air Filters

Disposable 2 inch filters furnished as standard.

OPTIONS/ACCESSORIES

Field Installed

Indoor Air Quality (CO₂) Sensor

Monitors CO₂ levels.

Replaceable Media Filter Kit With Frame

Permanent, metal frame filters with 2 inch polyester replaceable media.

ELECTRICAL

REQUIRED SELECTIONS

Voltage Choice

Specify 208/230V, 460V or 575V 3-phase-60hz when ordering base unit.

OPTIONS/ACCESSORIES

Factory or Field Installed

8 Electric Heat

Helix wound nichrome elements, time delay for element staging, individual element limit controls, wiring harness, may be two-stage controlled. When electric heat is factory installed, all required components are included. The following must be ordered extra when field installed electric heat is used: Unit Fuse Block and Electric Heat Control Module. See Electric Heat tables for ordering information, Pages 21-27.

Field Installed

Circuit Breakers up to 175 Amp

HACR circuit breaker without power distribution lugs. Accessible from outside of unit, spring-loaded weatherproof cover furnished. Main power to the unit is field connected to the circuit breaker which allows all power to be shutoff for service. Circuit breaker is sized to the unit maximum overcurrent protection (MOCP) size.

Disconnect Switch up to 250 Amp

Accessible from outside of unit, spring loaded weatherproof cover furnished. Main power to the unit is field connected to the disconnect which allows all power to be shut off for service. See Optional Electric Heat Accessories tables, Pages 21-27 for field installed disconnect switches.

GFI Service Outlets (2)

115v ground fault circuit interrupter (GFCI) type, field wired.

FEATURES AND BENEFITS

CABINET

9 Construction

Heavy-gauge steel panels and full perimeter heavy-gauge galvanized steel base rail provides structural integrity for transportation, handling, and installation.

Base rails have rigging holes. Three sides of the base rail have fork slots.

Raised edges around duct and power entry openings in the bottom of the unit provide additional protection against water entering the building.

Air-Flow Choice

Units are available in down-flow (vertical) or horizontal return air flow configuration.

Horizontal air flow requires Horizontal Roof Curb.

Horizontal Return Air Panel Kit is also required if converting a down-flow configured unit to horizontal air flow.

Power Entry

Electrical lines can be brought through the unit base or through horizontal access knock-outs.

10 Exterior Panels

Constructed of heavy-gauge, galvanized steel with a two-layer enamel paint finish.

11 Insulation

All panels adjacent to conditioned air are fully insulated with non-hygroscopic fiberglass insulation.

Unit base is fully insulated. The insulation also serves as an air seal to the roof curb, eliminating the need to add a seal during installation.

12 Access Panels

Access panels are provided for the compressor/controls/heating section and the blower access and air filter/economizer section.

REQUIRED SELECTIONS

Air Flow Configuration

Specify horizontal or down-flow (vertical).

OPTIONS/ACCESSORIES

Factory Installed

Corrosion Protection

A completely flexible immersed coating with an electrodeposited dry film process. (AST ElectroFin E-Coat) Meets Mil Spec MIL-P-53084, ASTM B117 Standard Method Salt Spray Testing, ASTM 1153 Standard Specification for Methyl Isobutyl Ketone.

Hinged Access Panels

Large access panels are hinged and have quarter-turn latches for quick and easy access to maintenance areas (economizer / filter, compressor / controls, heating / blower).

OPTIONS/ACCESSORIES

Field Installed

Coil Guards

Painted, galvanized steel wire guards to protect outdoor coil. Not used with Hail Guards.

Hail Guards

Constructed of heavy gauge steel, painted to match cabinet, helps protect outdoor coils from hail damage. Not used with Coil Guards.

Horizontal Return Air Panel Kit

Required for horizontal applications with Horizontal Roof Curb, contains panel with return air opening for field replacement of existing unit panel and panel to cover bottom return air opening in unit, see dimension drawings.

SERVICEABILITY

Designed to streamline general maintenance and decrease troubleshooting time.

Marked & Color-Coded Wiring

All electrical wiring is color-coded and marked to identify which components it is connecting.

Electrical Plugs

Positive connection electrical plugs are used to connect common accessories or maintenance parts for easy removal or installation.

Access Panels

Large access panels are provided for quick and easy access to maintenance areas.

Blower Access

Blower assembly slides out of the unit for easy access.

TXV Access

Thermal expansion valves are located near the perimeter of the unit for easier access.

Thermal Expansion Valves

Removable element head allows change out of element and bulb without removing the TXV.

Coil Cleaning

Independently formed condenser coils allow separation for easier cleaning.

Standard Components

A large number of common maintenance parts are standard throughout the entire range of sizes (15 - 25 tons), reducing the need to carry a lot of different parts to the job or in inventory.

Compressor Access

Compressors are located near the perimeter of the unit for easier access.

Compressor Compartment

Compressors are isolated from the condenser air flow allowing system operation checks to be done without changing the air flow across the outdoor coils.

OPTIONS/ACCESSORIES

ECONOMIZER/OUTDOOR AIR/EXHAUST ACCESSORIES

Factory or Field Installed

13 Economizer

Parallel, gear-driven action return air and outdoor air dampers, plug-in connections to unit, nylon bearings, neoprene seals, 24 volt, spring return motor, adjustable minimum damper position, damper assembly slides in unit, outdoor air hood must be ordered separately, choice of economizer controls. Economizer modulates dampers to maintain a 55°F discharge air temperature.

Economizer Enthalpy Control

Senses outdoor air enthalpy and enables economizer if the enthalpy is less than the setpoint of the control.

Down-Flow Barometric Relief Dampers

Allows relief of excess return air static when economizer is near full open. Aluminum blade dampers prevent blow back and outdoor air infiltration during off cycle. Bird screen furnished.

Outdoor Air Damper Section

25% Manual Outdoor Air Dampers - Parallel blade dampers are manually adjustable to a fixed position.

25% Automatic Outdoor Air Damper - Parallel blade, gear-driven dampers are automatically adjusted with a two-position damper motor.

Economizer and Outdoor Air Damper Application Note: Minimum mixed air temperature in heating mode 30°F

Maximum mixed air temperature in cooling mode: 90°F

Power Exhaust Fans

C1PWRE20C-1 models have two, 1/3 hp motors with 20 in., five blade propeller-type fans with a total power input of 750 Watts and a total air volume of 8630 cfm at 0 in. w.g..

Motor is inherently protected and enclosed for maximum protection from weather, dust and corrosion. Installs internal to unit for down-flow applications only with economizer option, provides exhaust air pressure relief, interlocked to run when return air dampers are closed and supply air blower is operating, fan runs when outdoor air dampers are 50% open (adjustable), motor is overload protected, steel cabinet and hood painted to match unit, requires optional Down-flow Economizer Barometric Relief Dampers.

See Power Exhaust Blower Tables.

Field Installed

Economizer Control

Sensible Temperature Control - Senses outdoor air temperature and enables the economizer if the temperature is less than the set point of the control. Order two kits for differential control.

Single Outdoor Enthalpy Control - Senses outdoor air enthalpy and enables economizer if the enthalpy is less than the setpoint of the control.

Differential Enthalpy (Dual) Control - Two solid-state enthalpy sensors allow the control to select between outdoor air or return air, whichever has lower enthalpy.

Outdoor Air Hood

Required with Economizer, Outdoor Air Damper Sections, cleanable aluminum mesh fresh air filters furnished.

Down-Flow Barometric Relief Damper Hood

Protects exhaust air from recirculating into outdoor air stream.

Horizontal Barometric Relief Dampers

Allows relief of excess air when economizer is near full open. Aluminum blade dampers prevent blow back and outdoor air infiltration during off cycle. Field installed in return air duct. Bird screen furnished.

CEILING DIFFUSERS

OPTIONS/ACCESSORIES

Field Installed

Ceiling Diffusers

Aluminum grilles, large center grille, insulated diffuser box with flanges, hanging rings furnished, interior transition (even air flow), internally sealed (prevents recirculation), adapts to T-bar ceiling grids or plaster ceilings.

Transitions (Supply and Return)

Used with diffusers, installs in roof curb, galvanized steel construction, flanges furnished for duct connection to diffusers, fully insulated.

ROOF CURBS

OPTIONS/ACCESSORIES

Field Installed

Down-Flow

Nailer strip furnished, mates to unit, US National Roofing Contractors Approved, shipped knocked down. Available in 8, 14, 18, and 24 inch heights.

Horizontal

Converts unit from down-flow to horizontal (side) air flow, return air is on unit, supply air is on curb, see dimension drawings. Curbs for rooftop applications meet National Roofing Code requirements. Available in cliplock and standard versions.

Requires Horizontal Return Air Panel. Available in 26, 30, 37, and 41 inch heights.

Optional Insulation Kit is available to help prevent sweating.

Fastening Systems

Cliplock curbs use interlocking tabs to fasten together. No tools required. Standard roof curb corners fasten together with furnished hardware.

OPTIONS / ACCESSORIES

Item	Catalog No.	180	210	240	300S	
COOLING SYSTEM						
Compressor Crankcase Heater	208/230V - TACHK10/15-Y	76M34	x	x	x	x
	460V - TACHK10/15-G	76M35	x	x	x	x
	575V - TACHK10/15-J	76M76	x	x	x	x
Condensate Drain Trap	PVC - LTACDKP09/36	76M18	x	x	x	x
	Copper - LTACDKC09/36	76M19	x	x	x	x
Efficiency	Standard		○	○	○	○
	High		○	○	○	
High Pressure Switches	T1SNSR11C-2	43W00	x	x	x	x
Low Ambient Kit	T1SNSR12C-2	43W01	x	x	x	x
Refrigerant Type	R-22		○	○	○	○
BLOWER - SUPPLY AIR						
	Low Static Motor/Drive Combination		○	○	○	○
	Standard Static Motor/Drive Combination (stock unit)		○	○	○	○
	High Static Motor/Drive Combination		○	○	○	○
¹ Standard to Low Static Conversion Kit	Drive Kit #A - C1DRKT044-1	90M53	x			
	Drive Kit #2 - C1DRKT004-1	87M04		x		
	Drive Kit #9 - C1DRKT045-1	90M54			x	
	Drive Kit #7 - C1DRKT042-1	90M51				x
² High to Standard Static Conversion Kit	Drive Kit #3 - C1DRKT038-1	90M47	x			
	Drive Kit #7 - C1DRKT042-1	90M51		x		
CABINET						
Coil Guards	C1GARD20C-1	88K55	x	x	x	x
Corrosion Protection			○	○	○	○
Hail Guards	C1GARD10C-1	88K28	x	x	x	x
Hinged Access Panels			○	○	○	○
³ Horizontal Return Air Panel Kit	C1HRAP10C-1-	87M00	x	x	x	x
CONTROLS						
Blower Proving Switch	C0SWCH01AE-1	30K49	x	x	x	x
Dirty Filter Switch	C0SWCH00AE-1	30K48	x	x	x	x
Smoke Detector - Supply	LTASASDK10/36	70K87	x	x	x	x
Smoke Detector - Return	LTARASDK10/36	70K86	x	x	x	x
ECONOMIZER						
Economizer						
Economizer - Order Hood Separately	T1ECON10C-1	86M31	⊗	⊗	⊗	⊗
Hood for Economizer	C1HOOD10C	85M25	x	x	x	x
Economizer Controls						
Differential Enthalpy (dual)	C1SNSR07AE	86M33	x	x	x	x
Sensible (order two kits for Differential)	TASEK10/15	76M37	⊗	⊗	⊗	⊗
Single Outdoor Enthalpy	C1SNSR06AE	86M32	x	x	x	x
Barometric Relief						
Down-Flow Barometric Relief Dampers Order Hood Separately	LAGED18/24	16K98	⊗	⊗	⊗	⊗
Hood for Down-Flow LAGED	C1HOOD20C	85M26	x	x	x	x
Horizontal Barometric Relief Dampers - Hood Furnished	LAGEDH18/24	16K99	x	x	x	x

NOTE - The catalog and part numbers that appear here are for ordering field installed accessories only.

○ - Configure to Order (Factory Installed)

X - Field Installed.

¹ Standard static drive can be converted to low static drive with field installed kit.

² High static drive can be converted to standard static drive with field installed kit.

³ Required for horizontal applications with Horizontal Roof Curb.

OPTIONS / ACCESSORIES

Item	Catalog No.	180	210	240	300S
ELECTRICAL					
Voltage 60 hz	208/230V - 3 phase	○	○	○	○
	460V - 3 phase	○	○	○	○
	575V - 3 phase	○	○	○	○
HACR Circuit Breakers	30 to 150 Amp size available	x	x	x	x
Disconnect Switch	See Electrical/Electric Heat Tables for selection	x	x	x	x
GFI Service Outlets	LTAGFIK10/15 74M70	x	x	x	x
ELECTRIC HEAT					
15 kW	208/230V-3ph - ¹ EHA240-7.5-Y 99J16	⊗	⊗	⊗	⊗
	¹ EHA240S-7.5-Y 99J17	⊗	⊗	⊗	⊗
	460V-3ph - ¹ EHA240-7.5-G 99J18	⊗	⊗	⊗	⊗
	¹ EHA240S-7.5-G 99J19	⊗	⊗	⊗	⊗
	575V-3ph - ¹ EHA240-7.5-J 99J20	⊗	⊗	⊗	⊗
	¹ EHA240S-7.5-J 99J21	⊗	⊗	⊗	⊗
30 kW	208/230V-3ph - ¹ EHA360-15-Y 99J22	⊗	⊗	⊗	⊗
	¹ EHA360S-15-Y 99J23	⊗	⊗	⊗	⊗
	460V-3ph - ¹ EHA360-15-G 99J24	⊗	⊗	⊗	⊗
	¹ EHA360S-15-G 99J25	⊗	⊗	⊗	⊗
	208/230V-3ph - ¹ EHA360-15-J 99J26	⊗	⊗	⊗	⊗
	¹ EHA360S-15-J 99J27	⊗	⊗	⊗	⊗
45 kW	208/230V-3ph - ² EHA360-22.5-Y 99J28	⊗	⊗	⊗	⊗
	460V-3ph - ² EHA360-22.5-G 99J29	⊗	⊗	⊗	⊗
	575V-3ph - ² EHA360-22.5-J 99J30	⊗	⊗	⊗	⊗
60 kW	208/230V-3ph - ² EHA150-30-Y 99J07	⊗	⊗	⊗	⊗
	460V-3ph - ² EHA150-30-G 99J08	⊗	⊗	⊗	⊗
	575V-3ph - ² EHA150-30-J 99J09	⊗	⊗	⊗	⊗
90 kW	208/230V-3ph - ² EHA360-45-Y 99J31		⊗	⊗	⊗
	460V-3ph - ² EHA360-45-G 99J32		⊗	⊗	⊗
	575V-3ph - ² EHA360-45-J 99J33		⊗	⊗	⊗
ELECTRIC HEAT ACCESSORIES/OPTIONS - See Electrical/Electric Heat Tables for selection					
	LTB2 Terminal Block	⊗	⊗	⊗	⊗
	Electric Heat Control Kit	⊗	⊗	⊗	⊗
	Unit Fuse Block	⊗	⊗	⊗	⊗
OUTDOOR AIR					
Outdoor Air Dampers					
Damper Section - Order Hood Separately	Motorized -T1DAMP20C-1 86M30	⊗	⊗	⊗	⊗
	Manual - LAOAD18/24 16K93	⊗	⊗	⊗	⊗
Outdoor Air Hoods for Economizers and Outdoor Air Dampers					
Outdoor Air Hood (No. of Filters) 16 x 25 x 1 in.	C1HOOD10C-1 85M25	⊗	⊗	⊗	⊗
POWER EXHAUST FANS					
Standard Static	208/230V - C1PWRE20C-1Y 85M37	x	x	x	x
	460V - C1PWRE20C-1G 85M38	x	x	x	x
	575V - C1PWRE20C-1J 85M39	x	x	x	x

NOTE - The catalog and part numbers that appear here are for ordering field installed accessories only.

⊗ - Field Installed or Configure to Order (factory installed)

○ - Configure to Order (Factory Installed)

x - Field Installed.

¹ Order one of each.

² Order two of each

OPTIONS / ACCESSORIES

Item	Catalog No.	180	210	240	300S	
INDOOR AIR QUALITY						
Air Filters						
Replaceable Media Filter Kit with Frame 24 x 24 x 2 order 6 per unit	C1FLTR30C-1	44N61	x	x	x	x
Indoor Air Quality (CO₂) Sensors						
CO ₂ Sensor Duct Mounting Kit	COMISC19AE1-	85L43	x	x	x	x
Sensor - white case CO ₂ display	C0SNSR50AE1L	77N39	x	x	x	x
Sensor - white case no display	C0SNSR52AE1L	87N53	x	x	x	x
Sensor - black case CO ₂ display	C0SNSR51AE1L	87N52	x	x	x	x
Sensor - black case, no display	C0SNSR53AE1L	87N54	x	x	x	x
Aspiration Box for duct mounting	C0MISC16AE-1	90N43	x	x	x	x
Handheld CO ₂ Monitor	LTAIQSHM03/36	70N93	x	x	x	x
CEILING DIFFUSERS						
Step-Down - Order one	RTD11-185	29G06	x			
(Canada Only)	RTD11-150/180S	13K63	x			
	RTD11-275	29G07		x	x	x
(Canada Only)	RTD11-275S	13K64		x	x	x
Flush - Order one	FD11-185	29G10	x			
(Canada Only)	FD11-150/180S	13K58	x			
	FD11-275-R	29G11		x	x	x
(Canada Only)	FD11-275S	13K59		x	x	x
Transitions (Supply and Return) Order one	LASRT18	19K01	x			
(Canada Only)	LASRT18S	33K48	x			
	LASRT21/24	19K02		x	x	x
(Canada Only)	LASRT21/24S	33K49		x	x	x
ROOF CURBS - CLIPLOCK 1000						
Down-Flow						
8 in. height	C1CURB40C1-	26W32	x	x	x	x
14 in. height	LARMF18/30S-14	33K44	x	x	x	x
18 in. height	LARMF18/30S-18	33K45	x	x	x	x
24 in. height	LARMF18/30S-24	33K46	x	x	x	x
Horizontal						
26 in. height	LARMFH18/24S-26	33K47	x	x	x	x
37 in. height	LARMFH18/24S-37	45K70	x	x	x	x
ROOF CURBS - STANDARD						
Down-Flow						
14 in. height	LARMF18/36-14	16K87	x	x	x	x
24 in. height	LARMF18/36-24	16K88	x	x	x	x
Horizontal						
26 in. height	LARMFH18/24-26	97J33	x	x	x	x
37 in. height	LARMFH18/24-37	38K53	x	x	x	x
Insulation Kits						
for LARMFH18/24-26		73K32	x	x	x	x
for LARMFH18/24-37		73K34	x	x	x	x

NOTE - The catalog and part numbers that appear here are for ordering field installed accessories only.

⊗ - Field Installed or Configure to Order (factory installed)

X - Field Installed.

SPECIFICATIONS

15 - 17.5 TON

General Data	Nominal Tonnage Model No.	15 Ton		17.5 Ton		
		TCA180S2B Standard	TCA180H2B High	TCA210S2B Standard	TCA210H2B High	
Cooling Performance	Efficiency Type					
	Gross Cooling Capacity - Btuh	186,000	186,000	218,000	219,000	
	¹ Net Cooling Capacity - Btuh	180,000	180,000	210,000	210,000	
	ARI Rated Air Flow - cfm	6000	6000	6700	7000	
	Total Unit Power - kW	18.6	16.7	21.6	19.4	
	¹ EER (Btuh/Watt)	9.7	10.8	9.7	10.8	
	² Integrated Part Load Value (Btuh/Watt)	10.1	11.2	10.1	11.2	
Refrigerant Type		R-22	R-22	R-22	R-22	
Refrigerant Charge Furnished	Circuit 1	9 lbs. 0 oz.	11 lbs. 8 oz.	8 lbs. 0 oz.	11 lbs. 0 oz.	
	Circuit 2	9 lbs. 0 oz.	11 lbs. 8 oz.	8 lbs. 0 oz.	11 lbs. 0 oz.	
	Circuit 3	9 lbs. 0 oz.	11 lbs. 8 oz.	8 lbs. 0 oz.	11 lbs. 0 oz.	
	Circuit 4	---	---	---	11 lbs. 0 oz.	
Electric Heat Available - See page 18 for capacities		15, 30, 45 or 60 kW		15, 30, 45, 60 or 90 kW		
Compressor Type (no.)		Scroll (3)	Scroll (3)	Scroll (3)	Scroll (4)	
Outdoor Coils	Net face area - sq. ft. total	56.0	56.0	56.0	56.0	
	Tube diameter - in.	3/8	3/8	3/8	3/8	
	Number of rows	1	2	1	2	
	Fins per inch	20	20	20	20	
Outdoor Coil Fans	Motor horsepower	(4) 1/3	(4) 1/3	(4) 1/2	(4) 1/3	
	Motor rpm	1075	1075	1075	1075	
	Total Motor watts	1370	1395	1800	1395	
	Diameter - in. - No. of blades	(4) 24 - 3	(4) 24 - 3	(4) 24 - 3	(4) 24 - 3	
	Total Air volume - cfm	15,850	15,450	16,000	15,450	
Indoor Coils	Net face area - sq. ft. total	22.3	22.3	22.3	22.3	
	Tube diameter - in.	3/8	3/8	3/8	3/8	
	No. of rows	3	3	3	3	
	Fins per inch	14	14	14	14	
	Drain connection - number and size	(1) 1 in. NPT coupling				
Expansion device type		Balanced Port Thermostatic Expansion Valve, removeable power head				
^{3,4} Indoor Blower and Drive Selection	Nominal motor HP	Low Static	3 hp	3 hp	5 hp	5 hp
		Standard Static	3 hp	3 hp	5 hp	5 hp
		High Static	5 hp	5 hp	7.5 hp	7.5 hp
	Max. usable motor output (US Only)	Low Static	3.45 hp	3.45 hp	5.75 hp	5.75 hp
		Standard Static	3.45 hp	3.45 hp	5.75 hp	5.75 hp
		High Static	5.75 hp	5.75 hp	8.63 hp	8.63 hp
	Drive Kit	Low Static	#A - 535-725 rpm	#A - 535-725 rpm	#2 - 685-865 rpm	#2 - 685-865 rpm
		Standard Static	#1 - 710-965 rpm	#1 - 710-965 rpm	#3 - 850-1045 rpm	#3 - 850-1045 rpm
		High Static	#4 - 945-1185 rpm	#4 - 945-1185 rpm	#6 - 1045-1285 rpm	#6 - 1045-1285 rpm
	Field Installed Drive Kits	Standard to Low Static	#A - 535-725 rpm	#A - 535-725 rpm	#2 - 685-865 rpm	#2 - 685-865 rpm
High to Standard Static		#3 - 850-1045 rpm	#3 - 850-1045 rpm	#7 - 850-1045 rpm	#7 - 850-1045 rpm	
Blower wheel nominal diameter x width		(2) 15 x 15 in.				
Filters	Type of filter	Disposable				
	No. and size - in.	(6) 24 x 24 x 2				
Electrical characteristics		208/230V, 460V or 575V - 60 hertz - 3 phase				

NOTE - Net capacity includes evaporator blower motor heat deduction. Gross capacity does not include evaporator blower motor heat deduction.
¹ Certified in accordance with the ULE certification program, which is based on ARI Standard 340/360; 95°F outdoor air temperature and 80°F db/67°F wb entering evaporator air; minimum external duct static pressure.
² Integrated Part Load Value tested at 80°F outdoor air temperature.
³ Using total air volume and system static pressure requirements determine from blower performance tables rpm and motor output required. Maximum usable output of motors furnished are shown. In Canada, nominal motor output is also maximum usable motor output. If motors of comparable output are used, be sure to keep within the service factor limitations outlined on the motor nameplate.
⁴ Stocked models are available with standard static drives. High static drives are factory installed (configure to order). Low static drive can be factory installed (configure to order) or standard static drives can be converted to low static with field installed kit. High static models can be converted to standard static with field installed kit.

SPECIFICATIONS

20 - 25 TON

General Data	Nominal Tonnage Model No.	20 Ton		25 Ton	
		TCA240S2B Standard	TCA240H2B High	TCA300S2B Standard	
Cooling Performance	Gross Cooling Capacity - Btuh	243,000	251,000	302,000	
	Net Cooling Capacity - Btuh	232,000	240,000	286,000	
	ARI Rated Air Flow - cfm	8000	7500	9000	
	Total Unit Power - kW	24.4	22.2	30.1	
	¹ EER (Btuh/Watt)	9.7	10.8	9.5	
	³ Integrated Part Load Value (Btuh/Watt)	9.9	11.2	9.7	
	Refrigerant Type	R-22	R-22	R-22	
Refrigerant Charge Furnished	Circuit 1	11 lbs. 8 oz.	11 lbs. 8 oz.	11 lbs. 0 oz.	
	Circuit 2	11 lbs. 8 oz.	11 lbs. 8 oz.	11 lbs. 0 oz.	
	Circuit 3	11 lbs. 8 oz.	11 lbs. 8 oz.	11 lbs. 0 oz.	
	Circuit 4	- - -	11 lbs. 8 oz.	11 lbs. 0 oz.	
Compressor Type (no.)		Scroll (3)	Scroll (4)	Scroll (4)	
Electric Heat Available - See page 18 for capacities		15, 30, 45, 60 or 90 kW			
Outdoor Coils	Net face area - sq. ft. total	56.0	56.0	56.0	
	Tube diameter - in.	3/8	3/8	3/8	
	Number of rows	2	2	2	
	Fins per inch	20	20	20	
Outdoor Coil Fans	Motor horsepower	(4) 1/3	(4) 1/3	(4) 1/2	
	Motor rpm	1075	1075	1075	
	Total Motor watts	1395	1395	1800	
	Diameter - in. - No. of blades	(4) 24 - 3	(4) 24 - 3	(4) 24 - 3	
	Total Air volume - cfm	15,450	15,450	16,000	
Indoor Coils	Net face area - sq. ft. total	22.3	22.3	22.3	
	Tube diameter - in.	3/8	3/8	3/8	
	No. of rows	3	4	4	
	Fins per inch	14	14	14	
	Drain connection - number & size	(1) 1 in. NPT coupling	(1) 1 in. NPT coupling	(1) 1 in. NPT coupling	
Expansion device type		Balanced Port Thermostatic Expansion Valve, removeable power head			
^{4, 5} Indoor Blower and Drive Selection	Nominal motor HP	Low Static	5 hp	5 hp	7.5 hp
		Standard Static	7.5 hp	7.5 hp	10 hp
		High Static	10 hp	10 hp	N/A
	Max. usable motor output (US Only)	Low Static	5.75 hp	5.75 hp	8.63 hp
		Standard Static	8.63 hp	8.63 hp	11.5 hp
		High Static	11.5 hp	11.5 hp	N/A
	Drive Kit	Low Static	#2 - 685- 865 rpm	#2 - 685-865 rpm	#7 - 850-1045 rpm
		Standard Static	#7 - 850-1045 rpm	#7 - 850-1045 rpm	#6 - 1045-1285 rpm
		High Static	#6 - 1045-1285 rpm	#6 - 1045-1285 rpm	N/A
	Field Installed Low Static Drive Kit		#9 - 685-865 rpm	#9 - 685-865 rpm	#7 - 850-1045 rpm
Blower wheel nominal diameter x width		(2) 15 x 15 in.			
Filters	Type of filter	Disposable			
	No. and size - in.	(6) 24 x 24 x 2			
Electrical characteristics		208/230V, 460V or 575V - 60 hertz - 3 phase			

NOTE - Net capacity includes evaporator blower motor heat deduction. Gross capacity does not include evaporator blower motor heat deduction.

¹ Certified in accordance with the ULE certification program, which is based on ARI Standard 340/360; 95°F outdoor air temperature and 80°F db/67°F wb entering evaporator air; minimum external duct static pressure.

² Tested at conditions included in with ARI Standard 340/360; 95°F outdoor air temperature and 80°F db/67°F wb entering evaporator air; minimum external duct static pressure.

³ Integrated Part Load Value tested at 80°F outdoor air temperature.

⁴ Using total air volume and system static pressure requirements determine from blower performance tables rpm and motor output required. Maximum usable output of motors furnished are shown. In Canada, nominal motor output is also maximum usable motor output. If motors of comparable output are used, be sure to keep within the service factor limitations outlined on the motor nameplate.

⁵ Stocked models are available with standard static drives. High static drives are factory installed (configure to order). Low static drive can be factory installed (configure to order) or standard static drives can be converted to low static with field installed kit.

COOLING RATINGS

NOTE - For Temperatures and Capacities not shown in tables, see bulletin — Cooling Unit Rating Table Correction Factor Data in Miscellaneous Engineering Data section.

25 TON STANDARD EFFICIENCY - TWO COMPRESSORS OPERATING

TCA300S

Entering Wet Bulb Temperature	Total Air Volume		Outdoor Air Temperature Entering Outdoor Coil																							
			65°F (18°C)						75°F (24°C)						85°F (29°C)						95°F (35°C)					
			Total Cooling Capacity		Comp Motor kW Input	Sensible To Total Ratio (S/T) Dry Bulb			Total Cooling Capacity		Comp Motor kW Input	Sensible To Total Ratio (S/T) Dry Bulb			Total Cooling Capacity		Comp Motor kW Input	Sensible To Total Ratio (S/T) Dry Bulb			Total Cooling Capacity		Comp Motor kW Input	Sensible To Total Ratio (S/T) Dry Bulb		
			kBtuh	kW		75°F 24°C	80°F 27°C	85°F 29°C	kBtuh	kW		75°F 24°C	80°F 27°C	85°F 29°C	kBtuh	kW		75°F 24°C	80°F 27°C	85°F 29°C	kBtuh	kW		75°F 24°C	80°F 27°C	85°F 29°C
63°F (17°C)	8000	3775	149.4	43.8	8.28	.57	.74	.93	144.8	42.4	9.28	.58	.76	.95	140.0	41.0	10.36	.59	.78	.97	135.0	39.6	11.58	.60	.81	.99
	10000	4720	155.2	45.5	8.38	.62	.85	1.00	150.2	44.0	9.40	.64	.87	1.00	145.2	42.6	10.48	.66	.90	1.00	140.0	41.0	11.70	.68	.93	1.00
	12000	5665	159.8	46.8	8.46	.69	.94	1.00	154.8	45.4	9.48	.71	.97	1.00	149.8	43.9	10.58	.74	.98	1.00	144.8	42.4	11.82	.76	1.00	1.00
67°F (19°C)	8000	3775	158.4	46.4	8.42	.45	.55	.69	153.4	45.0	9.44	.45	.56	.71	148.2	43.4	10.54	.46	.57	.73	142.8	41.9	11.76	.46	.58	.76
	10000	4720	163.4	47.9	8.52	.47	.60	.80	158.0	46.3	9.54	.48	.60	.82	152.6	44.7	10.66	.49	.62	.85	146.8	43.0	11.88	.49	.64	.88
	12000	5665	167.0	48.9	8.58	.50	.66	.90	161.4	47.3	9.62	.51	.68	.93	155.8	45.7	10.72	.51	.71	.95	149.8	43.9	11.96	.52	.73	.97
71°F (22°C)	8000	3775	168.6	49.4	8.60	.34	.44	.53	163.2	47.8	9.66	.34	.44	.54	157.6	46.2	10.78	.34	.45	.55	151.6	44.4	12.00	.34	.45	.56
	10000	4720	173.4	50.8	8.70	.35	.46	.58	167.6	49.1	9.74	.35	.47	.59	161.8	47.4	10.86	.35	.48	.60	155.6	45.6	12.12	.35	.48	.61
	12000	5665	176.6	51.8	8.76	.36	.49	.63	170.6	50.0	9.80	.36	.50	.66	164.6	48.2	10.94	.36	.51	.68	158.2	46.4	12.20	.37	.52	.70

25 TON STANDARD EFFICIENCY - ALL COMPRESSORS OPERATING

TCA300S

Entering Wet Bulb Temperature	Total Air Volume		Outdoor Air Temperature Entering Outdoor Coil																							
			85°F (29°C)						95°F (35°C)						105°F (41°C)						115°F (46°C)					
			Total Cooling Capacity		Comp Motor kW Input	Sensible To Total Ratio (S/T) Dry Bulb			Total Cooling Capacity		Comp Motor kW Input	Sensible To Total Ratio (S/T) Dry Bulb			Total Cooling Capacity		Comp Motor kW Input	Sensible To Total Ratio (S/T) Dry Bulb			Total Cooling Capacity		Comp Motor kW Input	Sensible To Total Ratio (S/T) Dry Bulb		
			kBtuh	kW		75°F 24°C	80°F 27°C	85°F 29°C	kBtuh	kW		75°F 24°C	80°F 27°C	85°F 29°C	kBtuh	kW		75°F 24°C	80°F 27°C	85°F 29°C	kBtuh	kW		75°F 24°C	80°F 27°C	85°F 29°C
63°F (17°C)	8000	3775	291.6	85.5	20.84	.69	.85	1.00	281.2	82.4	23.30	.70	.87	1.00	270.0	79.1	26.04	.71	.90	1.00	257.8	75.6	29.16	.73	.92	1.00
	10000	4720	302.4	88.6	21.08	.74	.95	1.00	291.8	85.5	23.54	.76	.97	1.00	280.2	82.1	26.32	.78	1.00	1.00	268.0	78.5	29.46	.81	1.00	1.00
	12000	5665	311.8	91.4	21.28	.81	1.00	1.00	301.4	88.3	23.78	.84	1.00	1.00	290.0	85.0	26.60	.86	1.00	1.00	278.0	81.5	29.80	.89	1.00	1.00
67°F (19°C)	8000	3775	308.6	90.4	21.22	.54	.67	.81	297.4	87.2	23.68	.54	.68	.83	285.2	83.6	26.48	.55	.69	.85	272.0	79.7	29.60	.56	.70	.88
	10000	4720	317.8	93.1	21.46	.57	.72	.91	306.0	89.7	23.92	.58	.73	.93	293.2	85.9	26.68	.59	.76	.96	279.4	81.9	29.88	.60	.78	.99
	12000	5665	324.6	95.1	21.58	.60	.79	.99	312.4	91.6	24.06	.61	.81	1.00	299.2	87.7	26.90	.62	.83	1.00	285.0	83.5	30.10	.64	.87	1.00
71°F (22°C)	8000	3775	328.2	96.2	21.68	.40	.52	.64	316.0	92.6	24.16	.40	.53	.65	303.0	88.8	27.00	.41	.54	.67	288.8	84.6	30.22	.41	.55	.68
	10000	4720	337.0	98.8	21.86	.41	.56	.70	324.2	95.0	24.40	.42	.57	.71	310.6	91.0	27.22	.42	.58	.73	295.8	86.7	30.40	.43	.59	.75
	12000	5665	342.8	100.5	22.02	.43	.59	.76	329.6	96.6	24.54	.43	.60	.78	315.6	92.5	27.38	.44	.62	.81	300.2	88.0	30.58	.44	.63	.84

BLOWER DATA

15 TON

**BLOWER TABLE INCLUDES RESISTANCE FOR BASE UNIT WITH WET INDOOR COIL & AIR FILTERS IN PLACE.
FOR ALL UNITS ADD:**

- 1 - Any factory installed options air resistance (electric heat, economizer, etc.). See table below
- 2 - Any field installed accessories air resistance (duct resistance, diffuser, etc.). See page 19

Then determine from table the blower motor output and drive required.

0.40 to 1.50 in. w.g.

TCA180

Air Volume cfm	External Static (in. w.g.)																							
	0.40		0.50		0.60		0.70		0.80		0.90		1.00		1.10		1.20		1.30		1.40		1.50	
	RPM	BHP	RPM	BHP	RPM	BHP	RPM	BHP	RPM	BHP	RPM	BHP	RPM	BHP	RPM	BHP	RPM	BHP	RPM	BHP	RPM	BHP	RPM	BHP
	Low Static - 3 HP, Drive Kit A						Standard Static - 3 HP, Drive Kit 1																	
4800	577	1.13	620	1.31	662	1.48	702	1.66	742	1.83	777	2.01	811	2.18	842	2.36	872	2.54	902	2.72	932	2.89	960	3.07
5000	585	1.25	628	1.43	670	1.60	710	1.78	750	1.95	783	2.13	815	2.30	848	2.50	880	2.70	910	2.88	940	3.05	968	3.23
5500	605	1.45	648	1.65	690	1.85	728	2.05	765	2.25	800	2.45	835	2.65	865	2.85	895	3.05	925	3.25	955	3.45	983	3.65
6000	630	1.75	670	1.95	710	2.15	748	2.38	785	2.60	818	2.83	850	3.05	880	3.25	910	3.45	940	3.68	970	3.90	998	4.13
6500	650	2.05	690	2.28	730	2.50	768	2.75	805	3.00	838	3.23	870	3.45	900	3.70	930	3.95	958	4.18	985	4.40	1013	4.63
7000	675	2.35	715	2.63	755	2.90	790	3.15	825	3.40	858	3.68	890	3.95	920	4.20	950	4.45	978	4.70	1005	4.95	1030	5.18
7200	687	2.55	725	2.81	763	3.06	798	3.33	833	3.60	866	3.86	898	4.11	926	4.36	954	4.61	984	4.90	1013	5.19	1038	5.44

NOTE - Bold - To operate in this range, unit must be ordered with High Static Drive and drive kit #3 must be ordered separately for field installation.

1.60 to 2.60 in. w.g.

TCA180

Air Volume cfm	External Static (in. w.g.)																					
	1.60		1.70		1.80		1.90		2.00		2.10		2.20		2.30		2.40		2.50		2.60	
	RPM	BHP	RPM	BHP	RPM	BHP	RPM	BHP	RPM	BHP	RPM	BHP	RPM	BHP	RPM	BHP	RPM	BHP	RPM	BHP	RPM	BHP
	High Static - 5 HP, Drive Kit 4										Field Furnished Drive											
4800	987	3.24	1014	3.42	1041	3.60	1064	3.78	1087	3.95	1112	4.13	1136	4.30	1159	4.50	1181	4.70	1204	4.88	1226	5.06
5000	995	3.40	1020	3.60	1045	3.80	1070	3.98	1095	4.15	1118	4.33	1140	4.50	1163	4.70	1185	4.90	1208	5.10	1230	5.30
5500	1010	3.85	1035	4.05	1060	4.25	1085	4.48	1110	4.70	1133	4.90	1155	5.10	1178	5.30	1200	5.50	1220	5.70	1240	5.90
6000	1025	4.35	1050	4.58	1075	4.80	1098	5.00	1120	5.20	1145	5.43	1170	5.65	1193	5.88	1215	6.10	1235	6.33	1255	6.55
6500	1040	4.85	1065	5.10	1090	5.35	1115	5.60	1140	5.85	1163	6.08	1185	6.30	1205	6.53	1225	6.75	1248	7.00	1270	7.25
7000	1055	5.40	1080	5.68	1105	5.95	1130	6.20	1155	6.45	1178	6.70	1200	6.95	1220	7.20	1240	7.45	1263	7.73	1285	8.00
7200	1063	5.68	1088	5.94	1113	6.19	1136	6.44	1159	6.69	1182	6.96	1204	7.23	1226	7.50	1248	7.77	1269	8.03	1289	8.28

NOTE - Bold, italics - drive is capable of the values noted but will exceed motor horsepower.

OPTIONS / ACCESSORIES AIR RESISTANCE (in. w.g.)

Air Volume - cfm	Electric Heat	Economizer	Horizontal Roof Curb
4800	---	---	.08
5000	---	---	.08
5500	---	---	.10
6000	.01	---	.11
6500	.01	.02	.13
7000	.01	.04	.15
7200	.01	.05	.16

BLOWER DATA

17.5 TON

**BLOWER TABLE INCLUDES RESISTANCE FOR BASE UNIT WITH WET INDOOR COIL & AIR FILTERS IN PLACE.
FOR ALL UNITS ADD:**

- 1 - Any factory installed options air resistance (electric heat, economizer, etc.). See table below
 - 2 - Any field installed accessories air resistance (duct resistance, diffuser, etc.). See page 19
- Then determine from table the blower motor output and drive required.

0.30 to 1.30 in. w.g.

TCA210

Air Volume cfm	External Static (in. w.g.) Covered By Drive At Nominal Air With Economizer, Standard Filters And Wet Indoor Coil																						
	0.30		0.40		0.50		0.60		0.70		0.80		0.90		1.00		1.10		1.20		1.30		
	RPM	BHP	RPM	BHP	RPM	BHP	RPM	BHP	RPM	BHP	RPM	BHP	RPM	BHP	RPM	BHP	RPM	BHP	RPM	BHP	RPM	BHP	RPM
	Field Furnished				Low Static - 5 HP, Drive Kit 2								Standard Static - 5 HP, Drive Kit 3										
5600	609	1.51	652	1.71	694	1.91	732	2.12	769	2.33	803	2.53	837	2.73	868	2.93	899	3.13	928	3.33	957	3.53	
6000	630	1.75	670	1.95	710	2.15	748	2.38	785	2.60	818	2.83	850	3.05	880	3.25	910	3.45	940	3.68	970	3.90	
6500	650	2.05	690	2.28	730	2.50	768	2.75	805	3.00	838	3.23	870	3.45	900	3.70	930	3.95	958	4.18	985	4.40	
7000	675	2.35	715	2.63	755	2.90	790	3.15	825	3.40	858	3.68	890	3.95	920	4.20	950	4.45	978	4.70	1005	4.95	
7500	700	2.75	738	3.03	775	3.30	810	3.58	845	3.85	878	4.15	910	4.45	938	4.70	965	4.95	993	5.23	1020	5.50	
8000	725	3.20	763	3.50	800	3.80	833	4.08	865	4.35	898	4.65	930	4.95	958	5.23	985	5.50	1013	5.80	1040	6.10	
8400	746	3.55	783	3.87	819	4.18	853	4.49	886	4.80	916	5.12	946	5.43	974	5.73	1001	6.03	1029	6.35	1056	6.66	

NOTE - Bold - To operate in this range, unit must be ordered with High Static Drive and drive kit #7 must be ordered separately for field installation.

1.40 to 2.50 in. w.g.

TCA210

Air Volume cfm	External Static (in. w.g.) Covered By Drive At Nominal Air With Economizer, Standard Filters And Wet Indoor Coil																								
	1.40		1.50		1.60		1.70		1.80		1.90		2.00		2.10		2.20		2.30		2.40		2.50		
	RPM	BHP	RPM	BHP	RPM	BHP	RPM	BHP	RPM	BHP	RPM	BHP	RPM	BHP	RPM	BHP	RPM	BHP	RPM	BHP	RPM	BHP	RPM	BHP	RPM
	Standard Static - 5 HP, Drive Kit 3							High Static - 7.5 HP, Drive Kit 6																	
5600	985	3.74	1012	3.95	1037	4.15	1062	4.35	1087	4.58	1112	4.80	1135	5.00	1157	5.20	1180	5.41	1202	5.62	1223	5.83	1244	6.04	
6000	998	4.13	1025	4.35	1050	4.58	1075	4.80	1098	5.00	1120	5.20	1145	5.43	1170	5.65	1193	5.88	1215	6.10	1235	6.33	1255	6.55	
6500	1013	4.63	1040	4.85	1065	5.10	1090	5.35	1115	5.60	1140	5.85	1163	6.08	1185	6.30	1205	6.53	1225	6.75	1248	7.00	1270	7.25	
7000	1030	5.18	1055	5.40	1080	5.68	1105	5.95	1130	6.20	1155	6.45	1178	6.70	1200	6.95	1220	7.20	1240	7.45	1263	7.73	1285	8.00	
7500	1048	5.78	1075	6.05	1100	6.33	1125	6.60	1148	6.88	1170	7.15	1193	7.40	1215	7.65	1238	7.95	1260	8.25	1280	8.50	1300	8.75	
8000	1065	6.40	1090	6.70	1115	6.98	1140	7.25	1163	7.55	1185	7.85	1208	8.13	1230	8.40	1253	8.70	1275	9.00	1295	9.30	1315	9.60	
8400	1081	6.96	1106	7.26	1131	7.58	1156	7.89	1179	8.19	1201	8.49	1224	8.79	1246	9.09	1266	9.38	1286	9.67	1307	9.98	1328	10.29	

NOTE - Bold, italics - drive is capable of the values noted but will exceed motor horsepower.
Italics - field furnished drive

OPTIONS / ACCESSORIES AIR RESISTANCE (in. w.g.)

Air Volume - cfm	Electric Heat	Economizer	Horizontal Roof Curb
5600	---	---	.10
6000	.01	---	.11
6500	.01	.02	.13
7000	.01	.04	.15
7500	.01	.06	.17
8000	.02	.09	.19
8400	.02	.11	.21

BLOWER DATA

20 TON

**BLOWER TABLE INCLUDES RESISTANCE FOR BASE UNIT WITH WET INDOOR COIL & AIR FILTERS IN PLACE.
FOR ALL UNITS ADD:**

- 1 - Any factory installed options air resistance (electric heat, economizer, etc.). See table below
 - 2 - Any field installed accessories air resistance (duct resistance, diffuser, etc.). See page 19
- Then determine from table the blower motor output and drive required.

0.30 to 1.30 in. w.g.

TCA240

Air Volume cfm	External Static (in. w.g.) Covered By Drive At Nominal Air With Economizer, Standard Filters And Wet Indoor Coil																						
	0.30		0.40		0.50		0.60		0.70		0.80		0.90		1.00		1.10		1.20		1.30		
	RPM	BHP	RPM	BHP	RPM	BHP	RPM	BHP	RPM	BHP	RPM	BHP	RPM	BHP	RPM	BHP	RPM	BHP	RPM	BHP	RPM	BHP	RPM
	Low Static - 5 HP, Drive Kit 2										Standard Static - 7.5 HP, Drive Kit 7												
6400	648	1.99	688	2.22	727	2.46	764	2.69	801	2.92	834	3.15	866	3.39	896	3.62	926	3.85	954	4.08	981	4.30	
7000	675	2.35	715	2.63	755	2.90	790	3.15	825	3.40	858	3.68	890	3.95	920	4.20	950	4.45	978	4.70	1005	4.95	
7500	700	2.75	738	3.03	775	3.30	810	3.58	845	3.85	878	4.15	910	4.45	938	4.70	965	4.95	993	5.23	1020	5.50	
8000	725	3.20	763	3.50	800	3.80	833	4.08	865	4.35	898	4.65	930	4.95	958	5.23	985	5.50	1013	5.80	1040	6.10	
8500	750	3.65	788	3.98	825	4.30	858	4.60	890	4.90	920	5.23	950	5.55	978	5.85	1005	6.15	1033	6.48	1060	6.80	
9000	780	4.20	815	4.53	850	4.85	880	5.18	910	5.50	940	5.83	970	6.15	998	6.48	1025	6.80	1053	7.15	1080	7.50	
9600	811	4.87	845	5.22	879	5.57	910	5.94	941	6.31	970	6.67	999	7.02	1027	7.38	1054	7.74	1079	8.08	1104	8.41	

1.40 to 2.50 in. w.g.

TCA240

Air Volume cfm	External Static (in. w.g.) Covered By Drive At Nominal Air With Economizer, Standard Filters And Wet Indoor Coil																								
	1.40		1.50		1.60		1.70		1.80		1.90		2.00		2.10		2.20		2.30		2.40		2.50		
	RPM	BHP	RPM	BHP	RPM	BHP	RPM	BHP	RPM	BHP	RPM	BHP	RPM	BHP	RPM	BHP	RPM	BHP	RPM	BHP	RPM	BHP	RPM	BHP	RPM
	Standard Static						High Static - 10 HP, Drive Kit 6																		
6400	1008	4.53	1035	4.75	1060	4.98	1085	5.22	1110	5.45	1135	5.68	1157	5.91	1180	6.15	1202	6.40	1225	6.65	1246	6.88	1268	7.11	
7000	1030	5.18	1055	5.40	1080	5.68	1105	5.95	1130	6.20	1155	6.45	1178	6.70	1200	6.95	1220	7.20	1240	7.45	1263	7.73	1285	8.00	
7500	1048	5.78	1075	6.05	1100	6.33	1125	6.60	1148	6.88	1170	7.15	1193	7.40	1215	7.65	1238	7.95	1260	8.25	1280	8.50	1300	8.75	
8000	1065	6.40	1090	6.70	1115	6.98	1140	7.25	1163	7.55	1185	7.85	1208	8.13	1230	8.40	1253	8.70	1275	9.00	1295	9.30	1315	9.60	
8500	1085	7.10	1110	7.40	1135	7.73	1160	8.05	1183	8.35	1205	8.65	1228	8.95	1250	9.25	1270	9.55	1290	9.85	1310	10.15	1330	10.45	
9000	1105	7.83	1130	8.15	1153	8.45	1175	8.75	1198	9.08	1220	9.40	1243	9.75	1265	10.10	1288	10.45	1310	10.80	1330	11.10	1350	11.40	
9600	1129	8.77	1154	9.13	1177	9.46	1199	9.78	1222	10.14	1244	10.50	1267	10.87	1289	11.23	---	---	---	---	---	---			

NOTE - *italics* - field furnished drive.

OPTIONS / ACCESSORIES AIR RESISTANCE (in. w.g.)

Air Volume - cfm	Electric Heat	Economizer	Horizontal Roof Curb
6400	.01	.02	.13
7000	.01	.04	.15
7500	.01	.06	.17
8000	.02	.09	.19
8500	.02	.11	.21
9000	.04	.14	.24
9600	.05	.16	.26

BLOWER DATA

25 TON

**BLOWER TABLE INCLUDES RESISTANCE FOR BASE UNIT WITH WET INDOOR COIL & AIR FILTERS IN PLACE.
FOR ALL UNITS ADD:**

1 - Any factory installed options air resistance (electric heat, economizer, etc.). See table below

2 - Any field installed accessories air resistance (duct resistance, diffuser, etc.). See page 19

Then determine from table the blower motor output and drive required.

0.0 to 1.10 in. w.g.

TCA300S

Air Volume cfm	External Static (in. w.g.) Covered By Drive At Nominal Air With Economizer, Standard Filters And Wet Indoor Coil																									
	0.0		0.10		0.20		0.30		0.40		0.50		0.60		0.70		0.80		0.90		1.00		1.10			
	RPM	BHP	RPM	BHP	RPM	BHP	RPM	BHP	RPM	BHP	RPM	BHP	RPM	BHP	RPM	BHP	RPM	BHP	RPM	BHP	RPM	BHP	RPM	BHP	RPM	BHP
	Field Furnished Drive						Low Static - 7.5 HP, Drive Kit 7												Standard Static							
8000	725	3.20	763	3.50	800	3.80	833	4.08	865	4.35	898	4.65	930	4.95	958	5.23	985	5.50	1013	5.80	1040	6.310	1065	6.40		
8500	750	3.65	788	3.98	825	4.30	858	4.60	890	4.90	920	5.23	950	5.55	978	5.85	1005	6.15	1033	6.48	1060	6.80	1085	7.10		
9250	790	4.45	825	4.80	860	5.15	893	5.50	925	5.85	955	6.20	985	6.55	1013	6.88	1040	7.20	1065	7.53	1090	7.85	1115	8.20		
10000	835	5.40	868	5.78	900	6.15	930	6.50	960	6.85	988	7.23	1015	7.60	1043	7.98	1070	8.35	1095	8.70	1120	9.05	1145	9.43		
10750	875	6.40	908	6.83	940	7.25	970	7.65	1000	8.05	1028	8.45	1055	8.85	1080	9.25	1105	9.65	1130	10.05	1155	10.45	1178	10.83		
11500	915	7.40	948	7.88	980	8.35	1010	8.80	1040	9.25	1068	9.68	1095	10.10	1118	10.53	1140	10.95	1165	11.40	1190	11.85	1210	12.23		
12000	935	7.95	963	8.35	990	8.75	1020	9.23	1050	9.70	1075	10.15	1100	10.60	1125	10.98	1150	11.35	1173	11.80	1195	12.25				

NOTE - Bold, italics - drive is capable of the values noted but will exceed motor horsepower.

Bold - To operate in this range, unit must be ordered with Standard Static Drive and drive kit #7 must be ordered separately for field installation.

1.20 to 2.20 in. w.g.

TCA300S

Air Volume cfm	External Static (in. w.g.) Covered By Drive At Nominal Air With Economizer, Standard Filters And Wet Indoor Coil																							
	1.20		1.30		1.40		1.50		1.60		1.70		1.80		1.90		2.00		2.10		2.20			
	RPM	BHP	RPM	BHP	RPM	BHP	RPM	BHP	RPM	BHP	RPM	BHP	RPM	BHP	RPM	BHP	RPM	BHP	RPM	BHP	RPM	BHP	RPM	BHP
	Standard Static - 10 HP, Drive Kit 6										Field Furnished Drive													
8000	1090	6.70	1115	6.98	1140	7.25	1163	7.55	1185	7.85	1208	8.13	1230	8.40	1253	8.70	1275	9.00	1295	9.30	1315	9.60		
8500	1110	7.40	1135	7.73	1160	8.05	1183	8.35	1205	8.65	1228	8.95	1250	9.25	1270	9.25	1290	9.85	1310	10.15	1330	10.45		
9250	1140	8.55	1163	8.88	1185	9.20	1208	9.53	1230	9.85	1253	10.20	1275	10.55	1295	10.55	1315	11.20	---	---	---	---		
10000	1170	9.80	1193	10.15	1215	10.50	1238	10.88	1260	11.25	1283	11.62	---	---	---	---	---	---	---	---	---	---		
10750	1200	11.20	1222	11.57	---	---	---	---	---	---	---	---	---	---	---	---	---	---	---	---	---	---		
11500	1230	12.60	---	---	---	---	---	---	---	---	---	---	---	---	---	---	---	---	---	---	---	---		

OPTIONS / ACCESSORIES AIR RESISTANCE (in. w.g.)

Air Volume - cfm	Electric Heat	Economizer	Horizontal Roof Curb
8000	.02	.09	.13
8500	.02	.11	.15
9250	.04	.15	.18
10,000	.06	.19	.21
10,750	.10	.23	.25
11,000	.11	.25	.27

BLOWER DATA

CEILING DIFFUSER AIR RESISTANCE - in. w.g.

Air Volume cfm	Step-Down Diffuser						Flush Diffuser	
	RTD11-185			RTD11-275			FD11-185	FD11-275
	2 Ends Open	1 Side/2 Ends Open	All Ends & Sides Open	2 Ends Open	1 Side/2 Ends Open	All Ends & Sides Open		
5000	.51	.44	.39	---	---	---	.27	---
5200	.56	.48	.42	---	---	---	.30	---
5400	.61	.52	.45	---	---	---	.33	---
5600	.66	.56	.48	---	---	---	.36	---
5800	.71	.59	.51	---	---	---	.39	---
6000	.76	.63	.55	.36	.31	.27	.42	.29
6200	.80	.68	.59	---	---	---	.46	---
6400	.86	.72	.63	---	---	---	.50	---
6500	---	---	---	.42	.36	.31	---	.34
6600	.92	.77	.67	---	---	---	.54	---
6800	.99	.83	.72	---	---	---	.58	---
7000	1.03	.87	.76	.49	.41	.36	.62	.40
7200	1.09	.92	.80	---	---	---	.66	---
7400	1.15	.97	.84	---	---	---	.70	---
7500	---	---	---	.51	.46	.41	---	.45
7600	1.20	1.02	.88	---	---	---	.74	---
8000	---	---	---	.59	.49	.43	---	.50
8500	---	---	---	.69	.58	.50	---	.57
9000	---	---	---	.79	.67	.58	---	.66
9500	---	---	---	.89	.75	.65	---	.74
10,000	---	---	---	1.00	.84	.73	---	.81
10,500	---	---	---	1.10	.92	.80	---	.89
11,000	---	---	---	1.21	1.01	.88	---	.96

POWER EXHAUST FANS

Return Duct Negative Static Pressure		Air Volume Exhausted	
in. w.g.	Pa	cfm	L/s
0	0	8630	4070
0.05	12	8210	3875
0.10	25	7725	3645
0.15	37	7110	3355
0.20	50	6470	3055
0.25	62	5790	2730
0.30	75	5060	2390
0.35	87	4300	2030
0.40	100	3510	1655
0.45	112	2690	1270
0.50	125	1840	870

BLOWER DATA

CEILING DIFFUSER AIR THROW DATA

Model No.	Air Volume cfm	¹ Effective Throw Range -ft.	
		Step-Down	Flush
180 Models	Diffuser Model	RTD11-185	FD11-185
	5600	39 - 49	28 - 37
	5800	42 - 51	29 - 38
	6000	44 - 54	40 - 50
	6200	45 - 55	42 - 51
	6400	46 - 55	53 - 52
	6600	57 - 56	45 - 56

Model No.	Air Volume cfm	¹ Effective Throw Range -ft.	
		Step-Down	Flush
210, 240, 300S Models	Diffuser Model	RTD11-185	FD11-185
	7200	33 - 38	26 - 35
	7400	35 - 40	28 - 37
	7600	36 - 41	29 - 38
	7800	38 - 43	40 - 50
	8000	39 - 44	42 - 51
	8200	41 - 46	43 - 52
	8400	43 - 49	44 - 54
	8600	44 - 50	46 - 57
	8800	47 - 55	48 - 59

¹ Throw is the horizontal or vertical distance an airstream travels on leaving the outlet or diffuser before the maximum velocity is reduced to 50 ft. (15 m) per minute. Four sides open.

UNIT CLEARANCES - INCHES (MM)

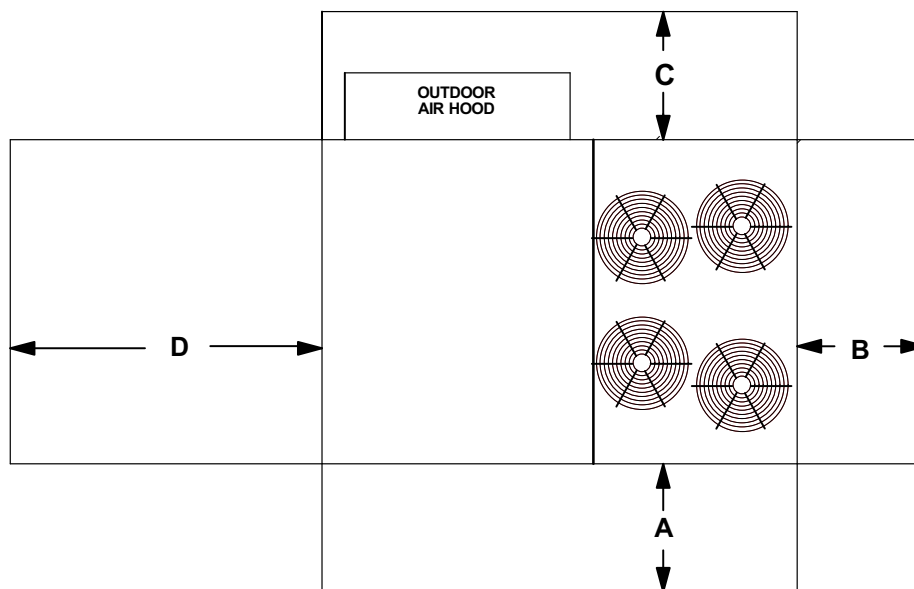

¹ Unit Clearance	A		B		C		D		Top Clearance
	in.	mm	in.	mm	in.	mm	in.	mm	
Service Clearance	60	1524	36	914	36	914	66	1676	Unobstructed
Minimum Operation Clearance	45	1143	36	914	36	914	41	1041	

NOTE - Entire perimeter of unit base requires support when elevated above the mounting surface.

¹ **Service Clearance** - Required for removal of serviceable parts.

Minimum Operation Clearance - Required clearance for proper unit operation.

OUTDOOR SOUND DATA

Unit Model No.	Octave Band Sound Power Levels dBA, re 10 ⁻¹² Watts							¹ Sound Rating Number (dB)
	Center Frequency - HZ							
	125	250	500	1000	2000	4000	8000	
180	80	83	87	88	84	80	71	93
210, 240	77	83	87	87	84	80	71	92
300S	80	84	87	87	83	77	64	93

Note - The octave sound power data does not include tonal corrections.

¹ Tested according to ARI Standard 370-2001 test conditions.

ELECTRIC HEAT CAPACITIES

Volts Input	15 kW			30 kW			45 kW			60 kW			90 kW		
	kW Input	Btuh Output	No. of Steps	kW Input	Btuh Output	No. of Steps	kW Input	Btuh Output	No. of Steps	kW Input	Btuh Output	No. of Steps	kW Input	Btuh Output	No. of Steps
208	11.3	38,600	1	22.5	76,800	1	33.8	115,300	2	45.0	153,600	2	67.6	230,700	2
220	12.6	43,000	1	25.2	86,000	1	37.8	129,000	2	50.4	172,000	2	75.6	258,000	2
230	13.8	47,100	1	27.5	93,900	1	41.3	141,000	2	55.1	188,000	2	82.7	282,200	2
240	15.0	51,200	1	30.0	102,400	1	45.0	153,600	2	60.0	204,800	2	90.0	307,100	2
440	12.6	43,000	1	25.2	86,000	1	37.8	129,000	2	50.4	172,000	2	75.6	258,000	2
460	13.8	47,100	1	27.5	93,900	1	41.3	141,000	2	55.1	188,000	2	82.7	282,200	2
480	15.0	51,200	1	30.0	102,400	1	45.0	153,600	2	60.0	204,800	2	90.0	307,100	2
550	12.6	43,000	1	25.2	86,000	1	37.8	129,000	2	50.4	172,000	2	75.6	258,000	2
575	13.8	47,100	1	27.5	93,900	1	41.3	141,000	2	55.1	188,000	2	82.7	282,200	2
600	15.0	51,200	1	30.0	102,400	1	45.0	153,600	2	60.0	204,800	2	90.0	307,100	2

ELECTRICAL/ELECTRIC HEAT DATA

TCA180S

Voltage - 60hz - 3 phase		208/230V			460V			575V		
Compressors (3)	Rated Load Amps each (total)	15.6 (46.8)			7.5 (22.5)			6 (18)		
	Locked Rotor Amps each (total)	124 (372)			59.6 (178.8)			49.4 (148.2)		
Outdoor Fan Motors (4)	Full Load Amps each (total)	2.4 (9.6)			1.3 (5.2)			1.0 (4.0)		
	Locked Rotor Amps each (total)	4.7 (18.8)			2.4 (9.6)			1.9 (7.6)		
Optional Power Exhaust Fan (2)	Horsepower	1/3			1/3			1/3		
	Full Load Amps each (total)	4.8 (9.6)			2.6 (5.2)			2.0 (4.0)		
	Locked Rotor Amps each (total)	9.4 (18.8)			4.8 (9.6)			3.8 (7.2)		
Service Outlet 115V GFI		15 Amps			15 Amps			15 Amps		
Indoor Blower Motor	Horsepower	3	5	7.5	3	5	7.5	3	5	7.5
	Rated Load Amps	10.6	16.7	24.2	4.8	7.6	11	3.9	6.1	9
	Locked Rotor Amps	66	105	152	26.8	45.6	66	23.4	36.6	54
¹ Maximum Overcurrent Protection	Unit Only	80	90	110	40	40	50	30	35	40
	with power exhaust 0 kW	90	90	110	40	45	50	35	35	40
	15 kW	90	90	110	40	45	50	35	35	40
	30 kW	110	125	150	60	60	70	45	50	50
	45 kW	175	175	175	80	90	90	70	70	70
	60 kW	175	175	³ 200	90	90	90	70	70	80
² Minimum Circuit Ampacity	Unit Only	71	77	85	35	38	41	28	30	33
	with power exhaust 0 kW	76	82	90	37	40	44	30	32	35
	15 kW	76	82	90	37	40	44	30	32	35
	30 kW	110	118	127	55	58	63	44	47	50
	45 kW	155	163	172	77	81	85	62	65	68
	60 kW	164	172	181	82	85	90	66	68	72
⁴ Unit Fuse Block	Unit Only	56K96	25K15	25K18	25K10	25K10	25K13	25K08	25K09	25K10
	with power exhaust	25K15	25K15	25K18	25K10	25K11	25K13	25K09	25K09	25K10
Disconnect	0-30 kW	80M01	80M01	80M01	80M00	80M00	80M00	80M00	80M00	80M00
	45 kW	80M01	80M01	80M02	80M00	80M00	80M00	80M00	80M00	80M00
	60 kW	80M02	80M02	80M02	80M01	80M01	80M01	80M00	80M00	80M00
⁴ Electric Heat Control Kit		85M32	85M32	85M32	85M33	85M33	85M33	85M334	85M334	85M334

NOTE - Extremes of operating range are plus and minus 10% of line voltage.

¹ HACR type breaker or fuse.

² Refer to National or Canadian Electrical Code manual to determine wire, fuse and disconnect size requirements.

³ Circuit breaker must be field provided.

⁴ Only used with electric heat.

ELECTRICAL/ELECTRIC HEAT DATA
TCA180H

Voltage - 60hz - 3 phase		208/230V			460V			575V		
Compressors (3)	Rated Load Amps each (total)	15.4 (46.2)			7.4 (22.2)			5.9 (17.7)		
	Locked Rotor Amps each (total)	124 (372)			59.6 (178.8)			49.4 (148.2)		
Outdoor Fan Motors (4)	Full Load Amps each (total)	2.4 (9.6)			1.3 (5.2)			1.0 (4.0)		
	Locked Rotor Amps each (total)	4.7 (18.8)			2.4 (9.6)			1.9 (7.6)		
Optional Power Exhaust Fan (2)	Horsepower	1/3			1/3			1/3		
	Full Load Amps each (total)	4.8 (9.6)			2.6 (5.2)			2.0 (4.0)		
	Locked Rotor Amps each (total)	9.4 (18.8)			4.8 (9.6)			3.8 (7.2)		
Service Outlet 115V GFI		15 Amps			15 Amps			15 Amps		
Indoor Blower Motor	Horsepower	3	5	7.5	3	5	7.5	3	5	7.5
	Rated Load Amps	10.6	16.7	24.2	4.8	7.6	11	3.9	6.1	9
	Locked Rotor Amps	66	105	152	26.8	45.6	66	23.4	36.6	54
¹ Maximum Overcurrent Protection	Unit Only	80	90	110	40	40	50	30	35	40
	with power exhaust 0 kW	90	90	110	40	45	50	35	35	40
	15 kW	90	90	110	40	45	50	35	35	40
	30 kW	110	125	150	60	60	70	45	50	50
	45 kW	175	175	175	80	90	90	70	70	70
	60 kW	175	175	³ 200	90	90	90	70	70	80
² Minimum Circuit Ampacity	Unit Only	71	77	84	35	37	41	28	30	33
	with power exhaust 0 kW	76	82	89	37	40	43	30	32	35
	15 kW	76	82	89	37	40	43	30	32	35
	30 kW	110	118	127	55	58	63	44	47	50
	45 kW	155	163	172	77	81	85	62	65	68
	60 kW	164	172	181	82	85	90	66	68	72
⁴ Unit Fuse Block	Unit Only	56K96	25K15	25K18	25K10	25K10	25K13	25K08	25K09	25K10
	with power exhaust	25K15	25K15	25K18	25K10	25K11	25K13	25K09	25K09	25K10
Disconnect	0-30 kW	80M01	80M01	80M01	80M00	80M00	80M00	80M00	80M00	80M00
	45 kW	80M01	80M01	80M02	80M00	80M00	80M00	80M00	80M00	80M00
	60 kW	80M02	80M02	80M02	80M01	80M01	80M01	80M00	80M00	80M00
⁴ Electric Heat Control Kit		85M32	85M32	85M32	85M33	85M33	85M33	85M34	85M34	85M34

NOTE - Extremes of operating range are plus and minus 10% of line voltage.

¹ HACR type breaker or fuse.

² Refer to National or Canadian Electrical Code manual to determine wire, fuse and disconnect size requirements.

³ Circuit breaker must be field provided.

⁴ Only used with electric heat.

ELECTRICAL/ELECTRIC HEAT DATA

TCA210S

Voltage - 60hz - 3 phase		208/230V			460V			575V		
Compressors (3)	Rated Load Amps each (total)	20.2 (60.6)			9.7 (29.1)			8 (24)		
	Locked Rotor Amps each (total)	156 (468)			75 (225)			54 (162)		
Outdoor Fan Motors (4)	Full Load Amps each (total)	3 (12)			1.5 (6)			1.2 (4.8)		
	Locked Rotor Amps each (total)	6 (24)			3 (12)			2.9 (11.6)		
Optional Power Exhaust Fan (2)	Horsepower	1/3			1/3			1/3		
	Full Load Amps each (total)	4.8 (9.6)			2.6 (5.2)			2.0 (4.0)		
	Locked Rotor Amps each (total)	9.4 (18.8)			4.8 (9.6)			3.8 (7.2)		
Service Outlet 115V GFI		15 Amps			15 Amps			15 Amps		
Indoor Blower Motor	Horsepower	3	5	7.5	3	5	7.5	3	5	7.5
	Rated Load Amps	10.6	16.7	24.2	4.8	7.6	11	3.9	6.1	9
	Locked Rotor Amps	66	105	152	26.8	45.6	66	23.4	36.6	54
1 Maximum Overcurrent Protection	Unit Only	100	110	125	50	50	50	40	40	45
	with power exhaust									
	0 kW	110	110	125	50	50	60	40	45	50
	15 kW	110	110	125	50	50	60	40	45	50
	30 kW	110	125	150	60	60	70	45	50	50
	45 kW	175	175	175	80	90	90	70	70	70
	60 kW	175	175	³ 200	90	90	90	70	70	80
90 kW	³ 250	³ 250	³ 300	125	125	150	100	100	110	
2 Minimum Circuit Ampacity	Unit Only	89	95	102	43	46	49	35	37	40
	with power exhaust									
	0 kW	94	100	107	45	48	52	37	39	42
	15 kW	94	100	107	45	48	52	37	39	42
	30 kW	110	118	127	55	58	63	44	47	50
	45 kW	155	163	172	77	81	85	62	65	68
	60 kW	164	172	181	82	85	90	66	68	72
90 kW	236	244	253	118	122	126	94	97	101	
4 Unit Fuse Block	Unit Only	25K17	25K18	25K19	25K13	25K13	25K13	25K10	25K10	25K11
	with power exhaust	25K18	25K18	25K19	25K13	25K13	25K14	25K10	25K11	25K13
Disconnect	0-30 kW	80M01	80M01	80M01	80M00	80M00	80M00	80M00	80M00	80M00
	45 kW	80M01	80M01	80M02	80M00	80M00	80M00	80M00	80M00	80M00
	60 kW	80M02	80M02	80M02	80M01	80M01	80M01	80M00	80M00	80M00
	90 kW	N/A	N/A	N/A	80M01	80M01	80M01	80M01	80M01	80M01
4 Electric Heat Control Kit		85M32	85M32	85M32	85M33	85M33	85M33	85M34	85M34	85M34

NOTE - Extremes of operating range are plus and minus 10% of line voltage.

¹ HACR type breaker or fuse.

² Refer to National or Canadian Electrical Code manual to determine wire, fuse and disconnect size requirements.

³ Circuit breaker must be field provided.

⁴ Only used with electric heat.

ELECTRICAL/ELECTRIC HEAT DATA

TCA210H

Voltage - 60hz - 3 phase		208/230V			460V			575V		
Compressors (4)	Rated Load Amps each (total)	14.7 (58.8)			7.1 (28.4)			5.1 (20.4)		
	Locked Rotor Amps each (total)	91 (364)			50 (200)			37 (148)		
Outdoor Fan Motors (4)	Full Load Amps each (total)	2.4 (9.6)			1.3 (5.2)			1.0 (4.0)		
	Locked Rotor Amps each (total)	4.7 (18.8)			2.4 (9.6)			1.9 (7.6)		
Optional Power Exhaust Fan (2)	Horsepower	1/3			1/3			1/3		
	Full Load Amps each (total)	4.8 (9.6)			2.6 (5.2)			2.0 (4.0)		
	Locked Rotor Amps each (total)	9.4 (18.8)			4.8 (9.6)			3.8 (7.2)		
Service Outlet 115V GFI		15 Amps			15 Amps			15 Amps		
Indoor Blower Motor	Horsepower	3	5	7.5	3	5	7.5	3	5	7.5
	Rated Load Amps	10.6	16.7	24.2	4.8	7.6	11	3.9	6.1	9
	Locked Rotor Amps	66	105	152	26.8	45.6	66	23.4	36.6	54
¹ Minimum Circuit Ampacity	Unit Only	83	89	97	41	43	47	30	32	35
	with power exhaust									
	0 kW	88	94	102	43	46	49	32	34	37
	15 kW	88	94	102	43	46	49	32	34	37
	30 kW	110	118	127	55	58	63	44	47	50
	45 kW	155	163	172	77	81	85	62	65	68
	60 kW	164	172	181	82	85	90	66	68	72
90 kW	236	244	253	118	122	126	94	97	101	
² Maximum Overcurrent Protection	Unit Only	90	110	110	45	50	50	30	35	40
	with power exhaust									
	0 kW	100	110	125	45	50	60	35	40	45
	15 kW	100	110	125	45	50	60	35	40	45
	30 kW	110	125	150	60	60	70	45	50	50
	45 kW	175	175	175	80	90	90	70	70	70
	60 kW	175	175	³ 200	90	90	90	70	70	80
90 kW	³ 250	³ 250	³ 300	125	125	150	100	100	110	
⁴ Unit Fuse Block	Unit Only	25K17	25K18	25K18	25K11	25K13	25K13	25K08	25K09	25K10
	with power exhaust	25K17	25K18	25K19	25K11	25K13	25K14	25K09	25K10	25K11
Disconnect	0-30 kW	80M01	80M01	80M01	80M00	80M00	80M00	80M00	80M00	80M00
	45 kW	80M01	80M01	80M02	80M00	80M00	80M00	80M00	80M00	80M00
	60 kW	80M02	80M02	80M02	80M01	80M01	80M01	80M00	80M00	80M00
	90 kW	N/A	N/A	N/A	80M01	80M01	80M01	80M01	80M01	80M01
⁴ Electric Heat Control Kit		85M32	85M32	85M32	85M33	85M33	85M33	85M34	85M34	85M34

NOTE - Extremes of operating range are plus and minus 10% of line voltage.

¹ HACR type breaker or fuse.

² Refer to National or Canadian Electrical Code manual to determine wire, fuse and disconnect size requirements.

³ Circuit breaker must be field provided.

⁴ Only used with electric heat.

ELECTRICAL/ELECTRIC HEAT DATA

TCA240S

Voltage - 60hz - 3 phase		208/230V			460V			575V		
Compressors (3)	Rated Load Amps each (total)	22.4 (67.2)			10.9 (32.7)			8.3 (24.9)		
	Locked Rotor Amps each (total)	164 (492)			100 (300)			78 (234)		
Outdoor Fan Motors (4)	Full Load Amps each (total)	2.4 (9.6)			1.3 (5.2)			1 (4)		
	Locked Rotor Amps each (total)	4.7 (18.8)			2.4 (9.6)			7.9 (7.6)		
Optional Power Exhaust Fan (2)	Horsepower	1/3			1/3			1/3		
	Full Load Amps each (total)	4.8 (9.6)			2.6 (5.2)			2.0 (4.0)		
	Locked Rotor Amps each (total)	9.4 (18.8)			4.8 (9.6)			3.8 (7.2)		
Service Outlet 115V GFI		15 Amps			15 Amps			15 Amps		
Indoor Blower Motor	Horsepower	5	7.5	10	5	7.5	10	5	7.5	10
	Rated Load Amps	16.7	24.2	30.8	7.6	11	14	6.1	9	11
	Locked Rotor Amps	105	152	193	45.6	66	84	36.6	54	66
1 Maximum Overcurrent Protection	Unit Only	110	125	125	50	60	60	45	45	50
	with power exhaust									
	0 kW	125	125	150	60	60	70	45	50	50
	15 kW	125	125	150	60	60	70	45	50	50
	30 kW	125	150	150	60	70	70	50	50	60
	45 kW	175	175	³ 200	90	90	90	70	70	80
	60 kW	175	³ 200	³ 200	90	90	100	70	80	80
90 kW	³ 250	³ 300	³ 300	125	150	150	100	110	110	
2 Minimum Circuit Ampacity	Unit Only	100	107	114	49	52	55	38	40	42
	with power exhaust									
	0 kW	104	112	118	51	55	58	40	42	44
	15 kW	104	112	118	51	55	58	40	42	44
	30 kW	117	127	135	58	63	66	47	50	53
	45 kW	163	172	180	81	85	89	65	68	71
	60 kW	172	181	189	85	90	93	68	72	74
90 kW	244	253	261	122	126	130	97	101	103	
4 Unit Fuse Block	Unit Only	25K18	25K19	25K19	25K13	25K14	25K14	25K11	25K11	25K13
	with power exhaust	25K19	25K19	35K01	25K14	25K14	35K03	25K11	25K13	25K13
Disconnect	0-30 kW	80M01	80M01	80M01	80M00	80M00	80M00	80M00	80M00	80M00
	45 kW	80M01	80M02	80M02	80M00	80M00	80M01	80M00	80M00	80M00
	60 kW	80M02	80M02	80M02	80M01	80M01	80M01	80M00	80M00	80M01
	90 kW	N/A	N/A	N/A	80M01	80M01	80M01	80M01	80M01	80M01
4 Electric Heat Control Kit		85M32	85M32	85M32	85M33	85M33	85M33	85M34	85M34	85M34

NOTE - Extremes of operating range are plus and minus 10% of line voltage.

¹ HACR type breaker or fuse.

² Refer to National or Canadian Electrical Code manual to determine wire, fuse and disconnect size requirements.

³ Circuit breaker must be field provided.

⁴ Only used with electric heat.

ELECTRICAL/ELECTRIC HEAT DATA

TCA240H

Voltage - 60hz - 3 phase		208/230V			460V			575V		
Compressors (4)	Rated Load Amps each (total)	17.3 (69.2)			9 (36)			7.1 (28.4)		
	Locked Rotor Amps each (total)	123 (492)			62 (248)			50 (200)		
Outdoor Fan Motors (4)	Full Load Amps each (total)	2.4 (9.6)			1.3 (5.2)			1 (4)		
	Locked Rotor Amps each (total)	4.7 (18.8)			2.4 (9.6)			1.9 (7.6)		
Optional Power Exhaust Fan (2)	Horsepower	1/3			1/3			1/3		
	Full Load Amps each (total)	4.8 (9.6)			2.6 (5.2)			2.0 (4.0)		
	Locked Rotor Amps each (total)	9.4 (18.8)			4.8 (9.6)			3.8 (7.2)		
Service Outlet 115V GFI		15 Amps			15 Amps			15 Amps		
Indoor Blower Motor	Horsepower	5	7.5	10	5	7.5	10	5	7.5	10
	Rated Load Amps	16.7	24.2	30.8	7.6	11	14	6.1	9	11
	Locked Rotor Amps	105	152	193	45.6	66	84	36.6	54	66
¹ Maximum Overcurrent Protection	Unit Only	110	125	125	60	60	70	45	50	50
	with power exhaust	0 kW	110	125	150	60	60	70	45	50
	15 kW	110	125	150	60	60	70	45	50	50
	30 kW	125	150	150	60	70	70	50	50	60
	45 kW	175	175	³ 200	90	90	90	70	70	80
	60 kW	175	³ 200	³ 200	90	90	100	70	80	80
	90 kW	³ 250	³ 300	³ 300	125	150	150	100	110	110
² Minimum Circuit Ampacity	Unit Only	100	108	114	52	55	58	41	44	46
	with power exhaust	0 kW	105	113	119	54	58	61	43	46
	15 kW	105	113	119	54	58	61	43	46	48
	30 kW	117	127	135	58	63	66	47	50	53
	45 kW	163	172	180	81	85	89	65	68	71
	60 kW	172	181	189	85	90	93	68	72	74
	90 kW	244	253	261	122	126	130	97	101	103
⁴ Unit Fuse Block	Unit Only	25K18	25K19	25K19	25K14	25K14	35K03	25K11	25K13	25K13
	with power exhaust	25K18	25K19	35K01	25K14	25K14	35K03	25K11	25K13	25K13
Disconnect	0-30 kW	80M01	80M01	80M01	80M00	80M00	80M00	80M00	80M00	80M00
	45 kW	80M01	80M02	80M02	80M00	80M00	80M01	80M00	80M00	80M00
	60 kW	80M02	80M02	80M02	80M01	80M01	80M01	80M00	80M00	80M01
	90 kW	N/A	N/A	N/A	80M01	80M01	80M01	80M01	80M01	80M01
⁴ Electric Heat Control Kit		85M32	85M32	85M32	85M33	85M33	85M33	85M34	85M34	85M34

NOTE - Extremes of operating range are plus and minus 10% of line voltage.

¹ HACR type breaker or fuse.

² Refer to National or Canadian Electrical Code manual to determine wire, fuse and disconnect size requirements.

³ Circuit breaker must be field provided.

⁴ Only used with electric heat.

ELECTRICAL/ELECTRIC HEAT DATA

TCA300

Voltage - 60hz - 3 phase		208/230V			460V			575V		
Compressors (4)	Rated Load Amps each (total)	18.6 (74.4)			9.6 (38.4)			7.8 (31.2)		
	Locked Rotor Amps each (total)	156 (624)			75 (300)			54 (216)		
Outdoor Fan Motors (4)	Full Load Amps each (total)	3 (12)			1.5 (6)			1.2 (4.8)		
	Locked Rotor Amps each (total)	6 (24)			3 (12)			2.9 (11.6)		
Optional Power Exhaust Fan (2)	Horsepower	1/3			1/3			1/3		
	Full Load Amps each (total)	4.8 (9.6)			2.6 (5.2)			2.0 (4.0)		
	Locked Rotor Amps each (total)	9.4 (18.8)			4.8 (9.6)			3.8 (7.2)		
Service Outlet 115V GFI		15 Amps			15 Amps			15 Amps		
Indoor Blower Motor	Horsepower	5	7.5	10	5	7.5	10	5	7.5	10
	Rated Load Amps	16.7	24.2	30.8	7.6	11	14	6.1	9	11
	Locked Rotor Amps	105	152	193	45.6	66	84	36.6	54	66
1 Maximum Overcurrent Protection	Unit Only	125	125	150	60	60	70	50	50	60
	with power exhaust									
	0 kW	125	150	150	60	70	70	50	50	60
	15 kW	125	150	150	60	70	70	50	50	60
	30 kW	125	150	150	60	70	70	50	50	60
	45 kW	175	175	³ 200	90	90	90	70	70	80
	60 kW	175	³ 200	³ 200	90	90	100	70	80	80
90 kW	³ 250	³ 300	³ 300	125	150	150	100	110	110	
2 Minimum Circuit Ampacity	Unit Only	108	116	127	55	58	61	45	47	49
	with power exhaust									
	0 kW	113	121	132	57	61	64	47	49	51
	15 kW	118	126	132	57	61	64	47	49	51
	30 kW	118	127	135	58	63	66	47	50	53
	45 kW	163	172	180	81	85	89	65	68	71
	60 kW	172	181	189	85	90	93	68	72	74
90 kW	244	253	261	122	126	130	97	101	103	
4 Unit Fuse Block	Unit Only	25K19	25K19	35K01	25K14	25K14	35K03	25K13	25K13	25K14
	with power exhaust	25K19	35K01	35K01	25K14	35K03	35K03	25K13	25K13	25K14
Disconnect	0-30 kW	80M01	80M01	80M01	80M00	80M00	80M00	80M00	80M00	80M00
	45 kW	80M01	80M02	80M02	80M00	80M00	80M01	80M00	80M00	80M00
	60 kW	80M02	80M02	80M02	80M01	80M01	80M01	80M00	80M00	80M01
	90 kW	N/A	N/A	N/A	80M01	80M01	80M01	80M01	80M01	80M01
4 Electric Heat Control Kit		85M32	85M32	85M32	85M33	85M33	85M33	85M34	85M34	85M34

NOTE - Extremes of operating range are plus and minus 10% of line voltage.

¹ HACR type breaker or fuse.

² Refer to National or Canadian Electrical Code manual to determine wire, fuse and disconnect size requirements.

³ Circuit breaker must be field provided.

⁴ Only used with electric heat.

OPTIONAL CONVENTIONAL TEMPERATURE CONTROL SYSTEMS - FIELD INSTALLED

COMMERCIAL TOUCHSCREEN THERMOSTAT



Intuitive Touchscreen Interface - **Two Stage Heating / Two Stage Cooling Conventional or Heat Pump** - Seven Day Programmable - Four Time Periods/Day - Economizer Output - Title 24 Compliant - ENERGY STAR® Qualified - Backlit Display - Automatic Changeover

C0STAT02AE1L

Sensors For Touchscreen Thermostat

1 Remote non-adjustable wall mount 20k temperature sensor	C0SNZN01AE1-
1 Remote non-adjustable wall mount 10k averaging temperature sensor	C0SNZN73AE1-
1 Remote non-adjustable duct mount temperature sensor	C0SNDC00AE1-
Outdoor temperature sensor	C0SNSR03AE1-

Accessories For Touchscreen Thermostat

Locking cover (clear)	C0MISC15AE1-
-----------------------------	--------------

¹ Remote sensors for C0STAT02AE1L can be applied in the following combinations: (1) C0SNZN01AE1-, (2) C0SNZN73AE1-, (2) C0SNZN01AE1- and (1) C0SNZN73AE1-, (4) C0SNZN01AE1-, (3) C0SNZN01AE1- and (2) C0SNZN73AE1.

DIGITAL NON-PROGRAMMABLE THERMOSTATS



Intuitive Interface - Automatic Changeover - Simple Up and Down Temperature Control

Two-stage heating / cooling conventional systems	C0STAT10AE1L
---------------------------------------------------------------	--------------

Sensor For Digital Non-Programmable Thermostats Above

Remote wall mounted temperature sensor	C0SNZN00AE1-
----------------------------------------------	--------------



Intuitive Interface - Automatic Changeover - Backlit Display - Simple Up and Down Temperature Control

One-stage heating / cooling conventional systems	C0STAT12AE1L
---------------------------------------------------------------	--------------

Sensor For Digital Non-Programmable Thermostats Above

Outdoor temperature sensor	C0SNSR04AE1-
----------------------------------	--------------

Accessories For Digital Non-Programmable Thermostats Above

Optional wall mounting plate	C0MISC17AE1-
------------------------------------	--------------

WEIGHT DATA

Model Number	Net		Shipping	
	lbs.	kg	lbs.	kg
180S/210S Base Unit	2101	953	2301	1044
180S/210S Max. Unit	2306	1046	2506	1137
180H/240S Base Unit	2195	996	2395	1086
180H/240S Max. Unit	2400	1089	2600	1179
210H/240H/300S Base Unit	2320	1052	2520	1143
210H/240H/300S Max. Unit	2525	1145	2725	1236

OPTIONS / ACCESSORIES

		Weight	
		lbs.	kg.
CEILING DIFFUSERS			
Step-Down	RTD11-185	392	178
	RTD11-275	403	183
Flush	FD11-185	289	135
	FD11-275	363	165
Transitions	LASRT18	80	36
	LASRT21/24	75	34

ECONOMIZER / OUTDOOR AIR / EXHAUST

Economizer	T1ECON10C-1	86	39
Barometric Relief			
Down-Flow Barometric Relief Dampers	LAGED18/24	30	14
Horizontal Barometric Relief Dampers	LAGEDH18/24	20	9
Outdoor Air Dampers			
Damper Section (down-flow) - Automatic	T1DAMP20C-1	52	24
Damper Section (down-flow) - Manual	LAOAD18/24	49	22
Outdoor Air Hood (down-flow)	C1HOOD10C-1	65	29
Power Exhaust	C1-PWRE20C-1	62	28

ELECTRIC HEAT

15 kW		59	27
30 kW		59	27
45 kW		76	35
60 kW		76	35
90 kW		84	38

PACKAGING

LTL Packaging (less than truck load)		280	127
--------------------------------------	--	-----	-----

ROOF CURBS - CLIPLOCK 1000

Down-Flow			
14 in. height	LARMF18/30S-14	164	74
18 in. height	LARMF18/30S-18	187	85
24 in. height	LARMF18/30S-24	222	101
Horizontal			
26 in. height	LARMFH18/24S-26	335	152
37 in. height	LARMFH18/24S-37	445	202

ROOF CURBS - STANDARD

Down-Flow			
14 in. height	LARMF18/36-14	160	73
24 in. height	LARMF18/36-24	220	100
Horizontal			
26 in. height	LARMFH18/24-26	420	191
37 in. height	LARMFH18/24-37	580	263

Base Unit - The unit with NO OPTIONS.

Max. Unit - The unit with ALL OPTIONS Installed. (Electric Heat, Economizer, Power Exhaust Fans, Controls)

DIMENSIONS - INCHES (MM)

Model Number	AA		CORNER WEIGHTS				DD		CENTER OF GRAVITY			
	lbs.	kg	lbs. BB	kg	lbs. CC	kg	lbs.	kg	inch EE	mm	inch FF	mm
180S Base Unit	546	248	455	206	490	222	611	277	55	1397	39-1/4	997
180S Max. Unit	618	280	510	231	527	239	650	295	55	1397	42-3/4	1086
180H Base Unit	574	260	466	211	504	229	651	295	53-1/2	1359	38-3/4	984
180H Max. Unit	649	294	520	236	541	245	690	313	53-1/2	1359	42-1/4	1073
210S Base Unit	560	254	441	200	472	214	628	285	52	1321	39-1/2	1003
210S Max. Unit	636	288	494	224	508	230	668	303	52	1321	43	1092
210H Base Unit	607	275	492	223	533	242	688	312	53-1/2	1359	38-3/4	984
210H Max. Unit	683	310	548	250	569	258	726	329	53-1/2	1359	42-1/4	1073
240S Base Unit	571	259	476	216	511	232	637	289	55	1397	39-1/2	1003
240S Max. Unit	653	296	518	235	537	244	692	314	53	1346	42-1/2	1080
240H/300S Base Unit	595	270	506	230	549	249	670	304	56	1422	38-3/4	984
240H/300S Max. Unit	672	305	546	248	576	261	730	331	54	1372	41	1041

Base Unit - Unit with NO OPTIONS.

Max. Unit - Unit with ALL OPTIONS Installed. (Economizer, Power Exhaust Fans, Controls)

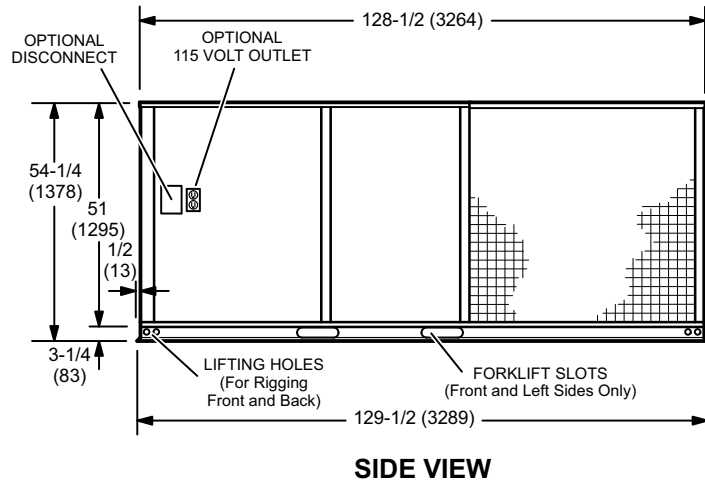
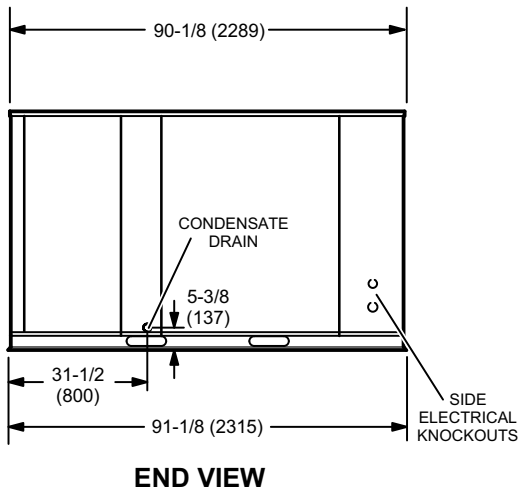
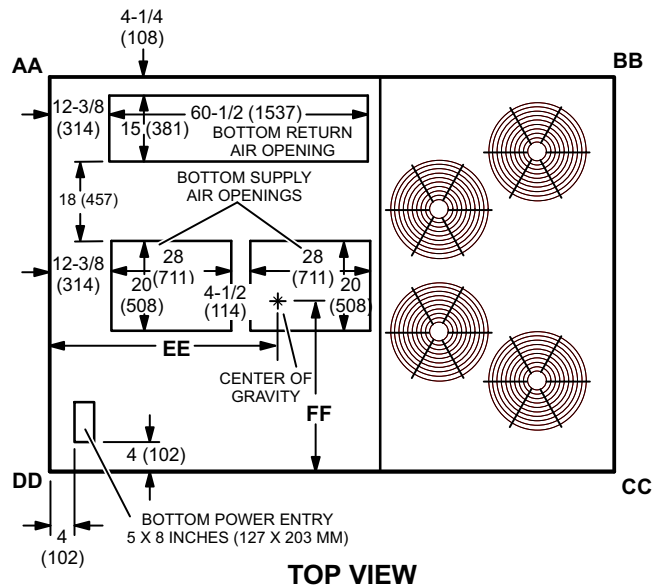

ACCESSORY DIMENSIONS - INCHES (MM)

OPTIONAL OUTDOOR AIR HOOD DETAIL WITH STANDARD STATIC POWER EXHAUST FANS

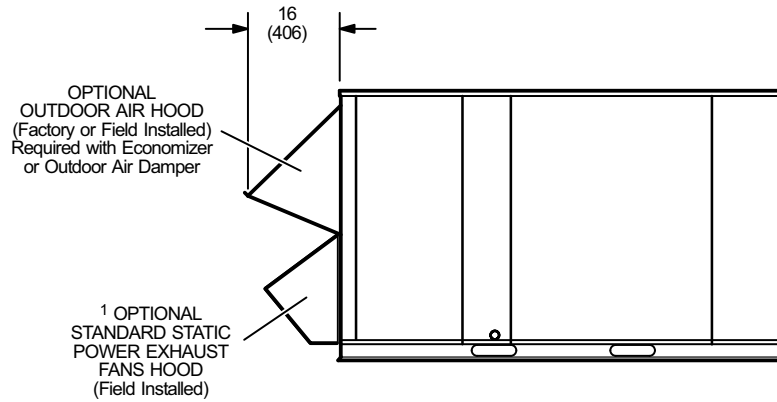

¹ Field Installed in Return Air Duct for Horizontal Applications.

HORIZONTAL BAROMETRIC RELIEF DAMPERS

(Field installed in horizontal return air duct adjacent to unit)

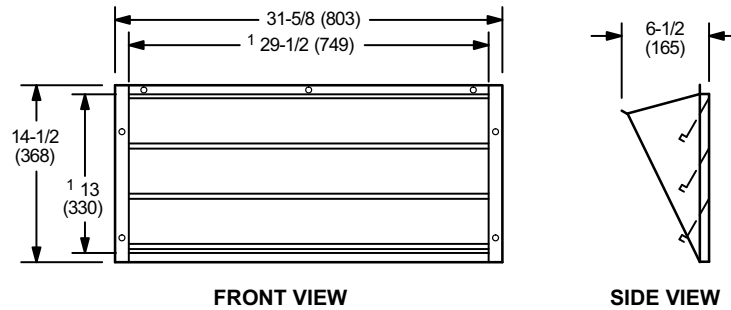

FRONT VIEW

SIDE VIEW

NOTE - Two furnished per order no.

¹ NOTE - Opening size required in return air duct.

ACCESSORY DIMENSIONS - INCHES (MM)

CLIPLOCK 1000 ROOF CURBS - DOUBLE DUCT OPENING

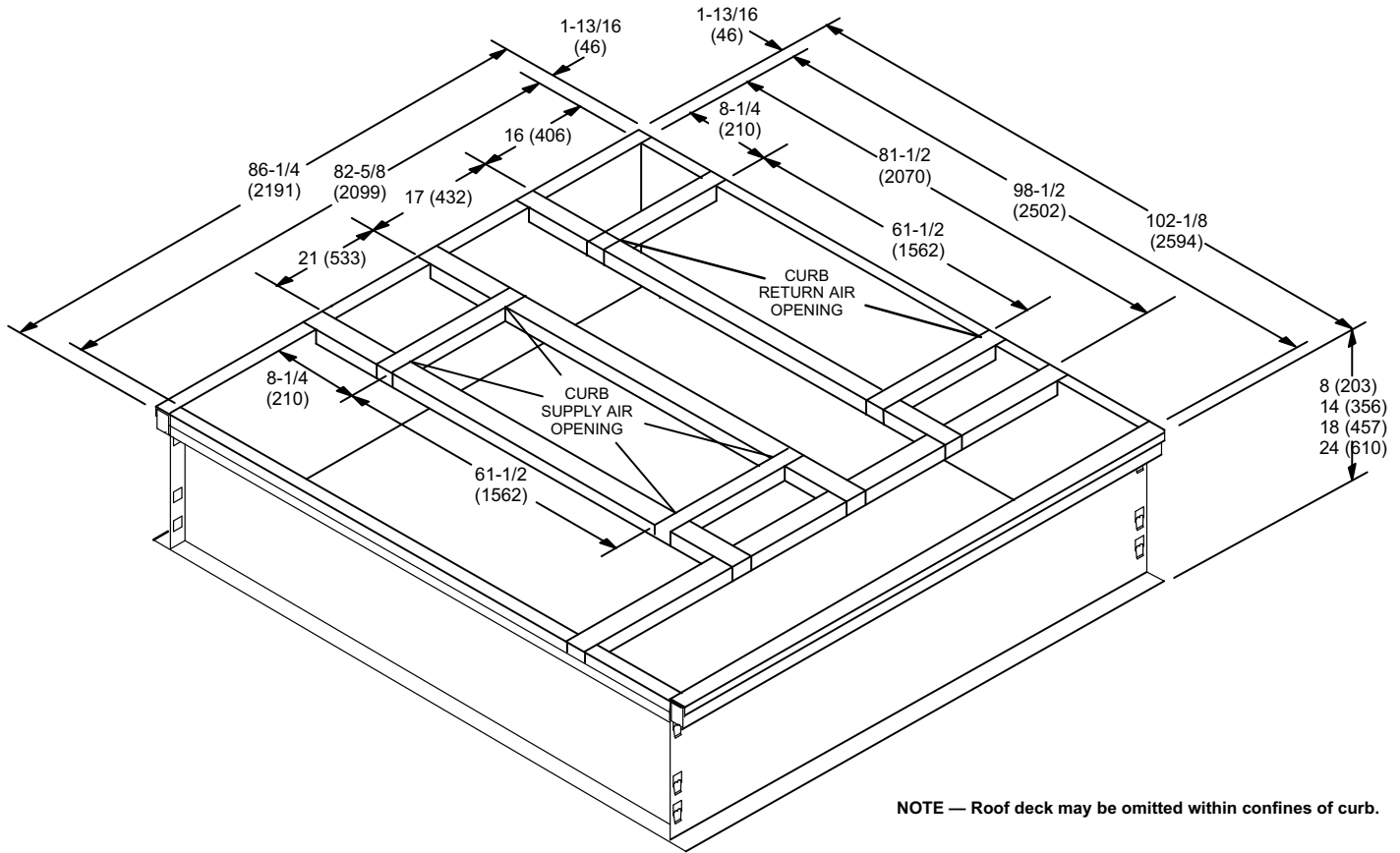

NOTE — Roof deck may be omitted within confines of curb.

TYPICAL FLASHING DETAIL FOR ROOF CURB

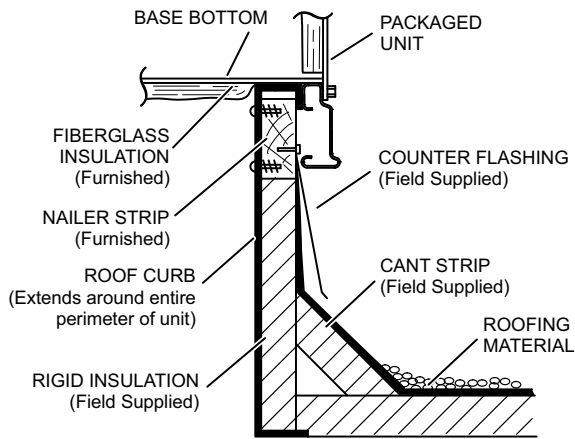

DETAIL ROOF CURB

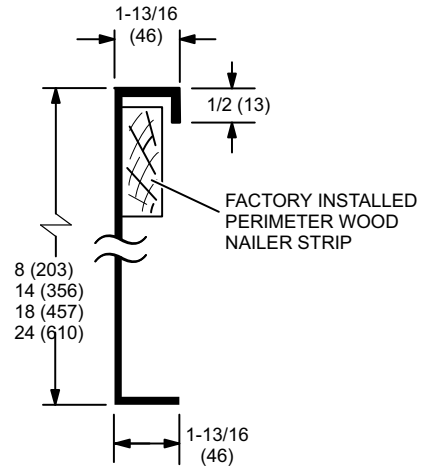

ACCESSORY DIMENSIONS - INCHES (MM)

STANDARD ROOF CURBS - DOUBLE DUCT OPENING

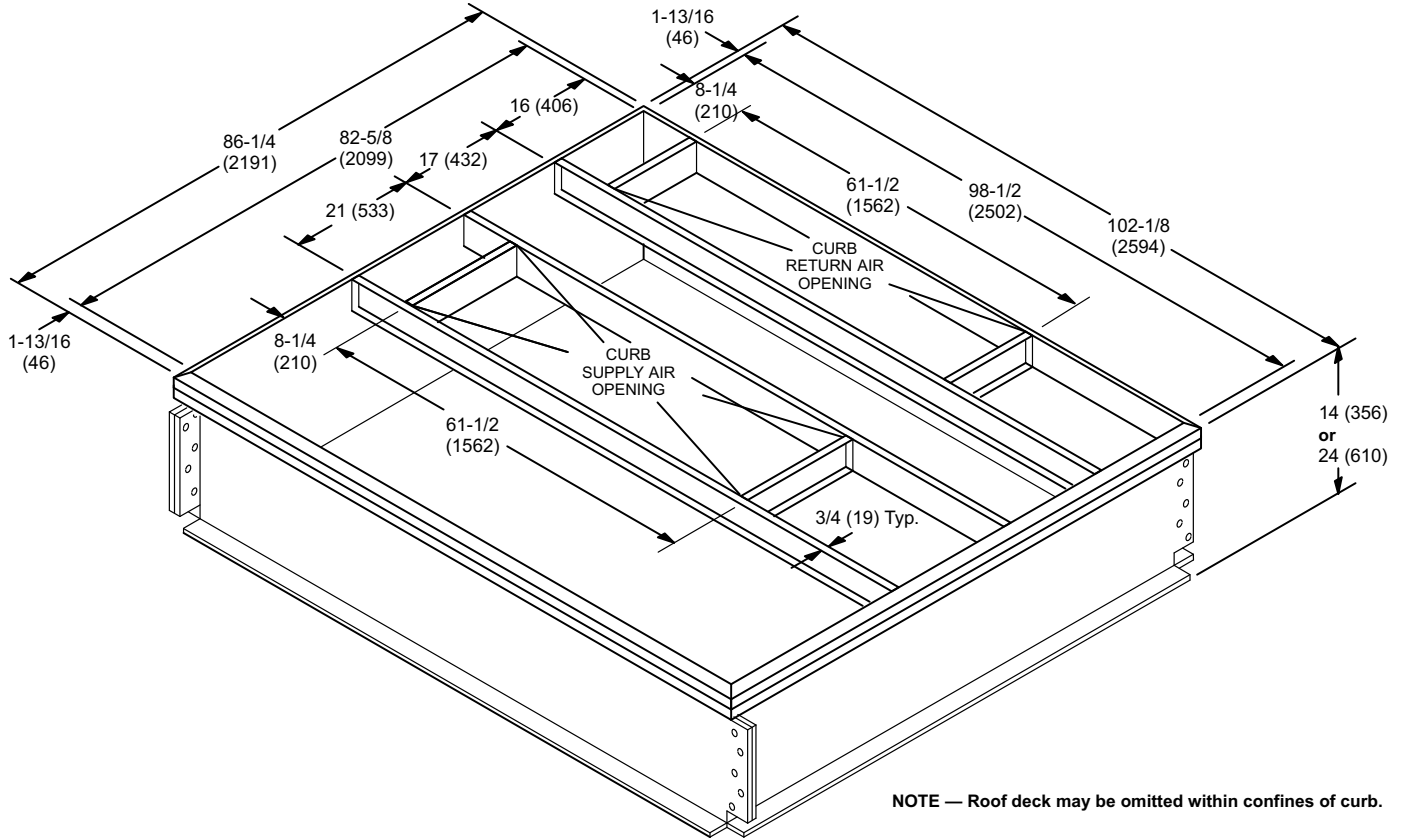

NOTE — Roof deck may be omitted within confines of curb.

TYPICAL FLASHING DETAIL FOR ROOF CURB

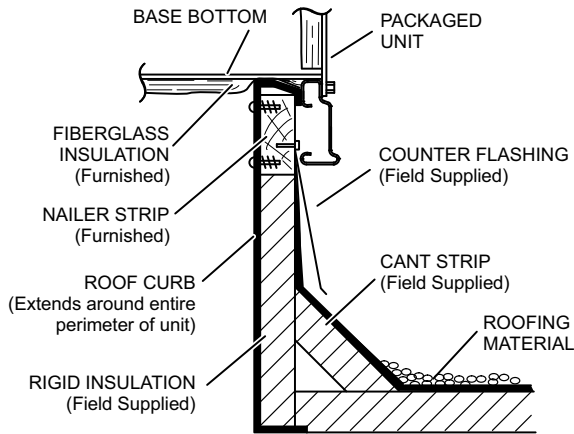

DETAIL ROOF CURB

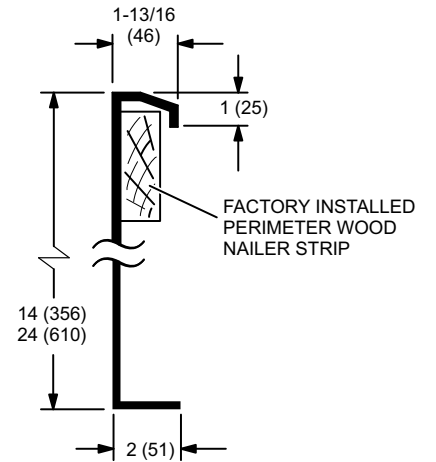

ACCESSORY DIMENSIONS - INCHES (MM)

ROOF CURBS WITH SUPPLY & RETURN AIR TRANSITIONS FOR CEILING DIFFUSERS

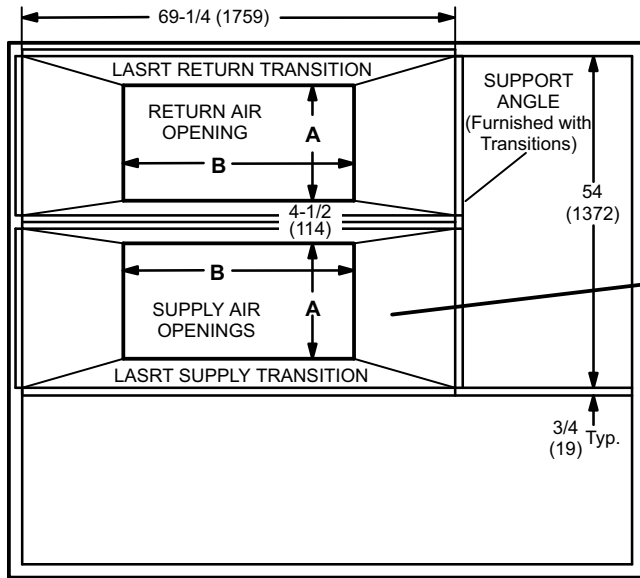

TOP VIEW

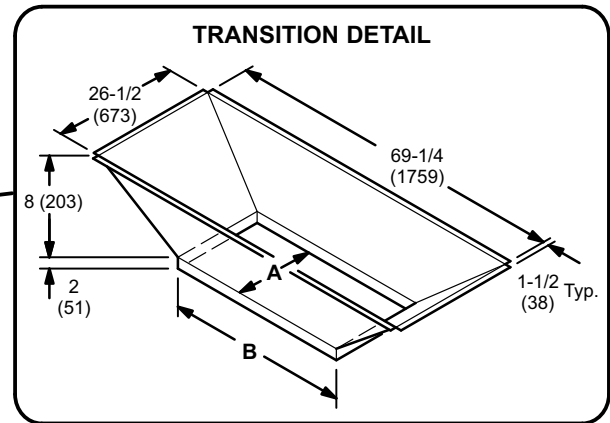

TRANSITION OPENING SIZES

Model Number	A		B	
	inch	mm	inch	mm
LASRT18	18	457	36	914
LASRT21/24	24	610	48	1219

ACCESSORY DIMENSIONS - INCHES (MM)

HORIZONTAL ROOF CURBS - Requires Optional Horizontal Return Air Panel Kit

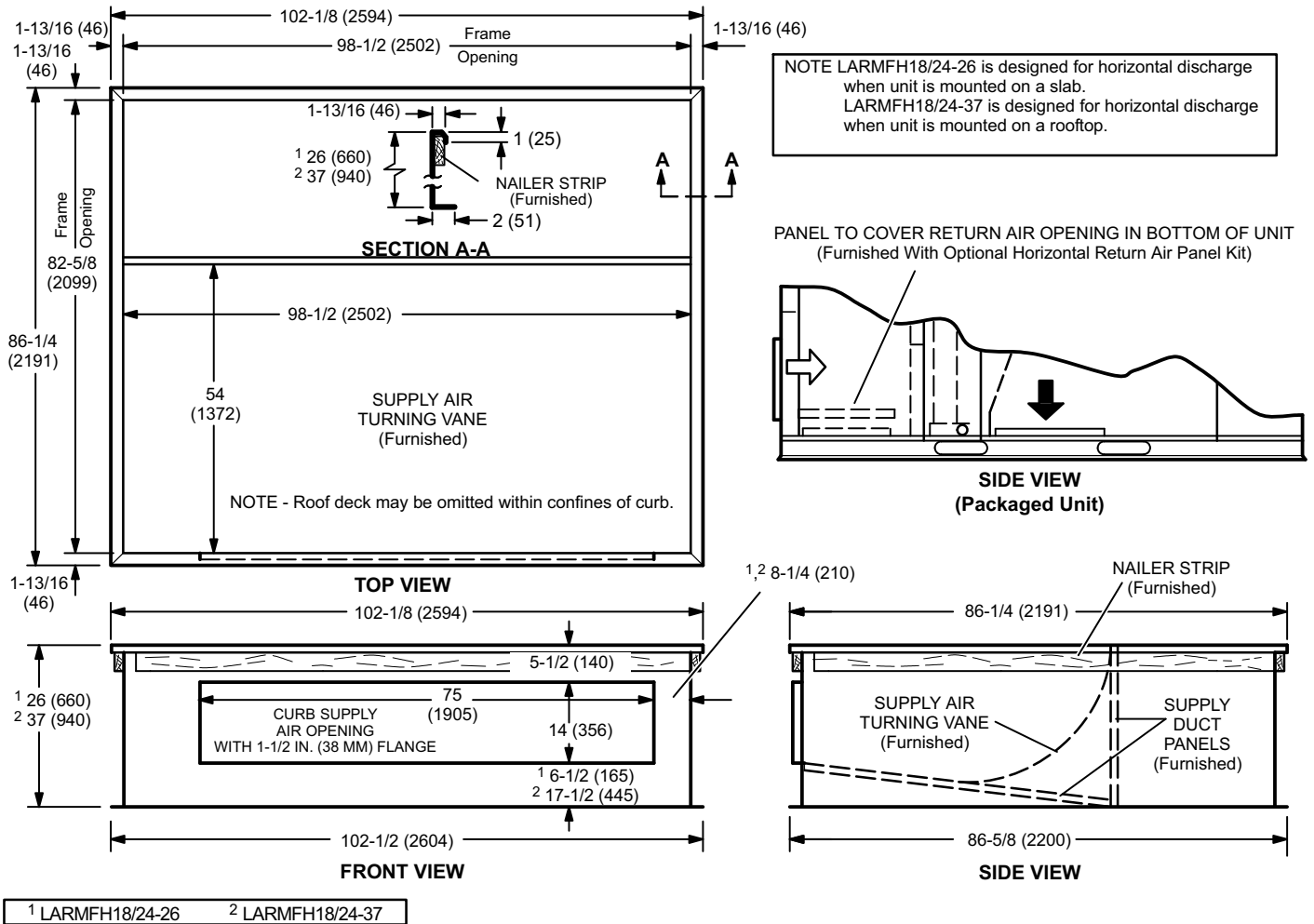

HORIZONTAL SUPPLY AND RETURN AIR OPENINGS WITH HORIZONTAL ROOF CURB

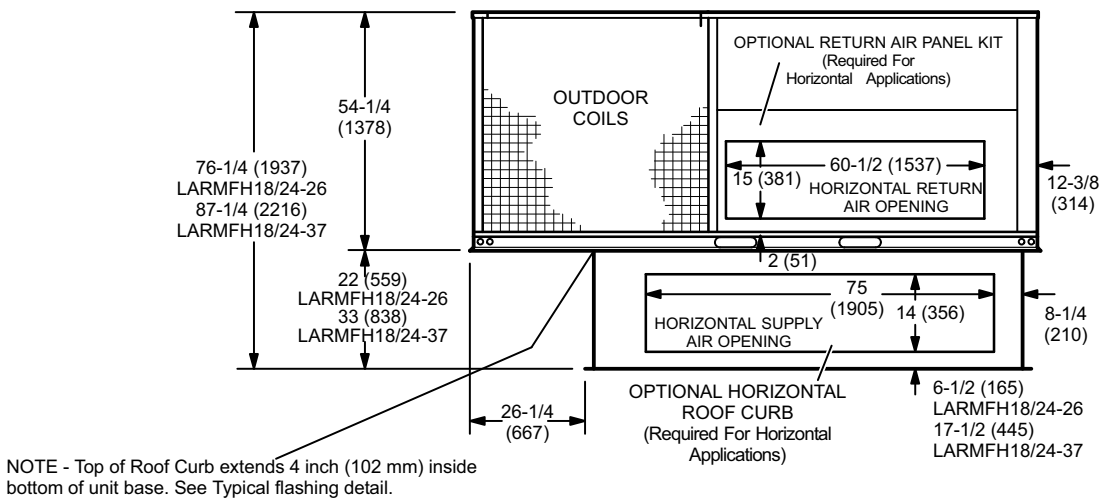

ACCESSORY DIMENSIONS - INCHES (MM)

COMBINATION CEILING SUPPLY AND RETURN DIFFUSERS

STEP-DOWN CEILING DIFFUSER

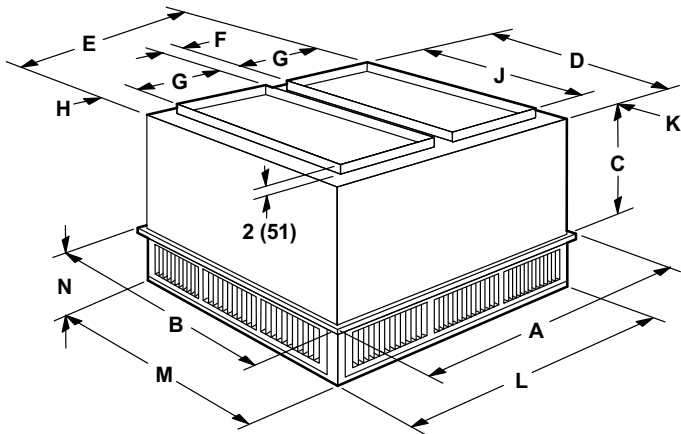

FLUSH CEILING DIFFUSER

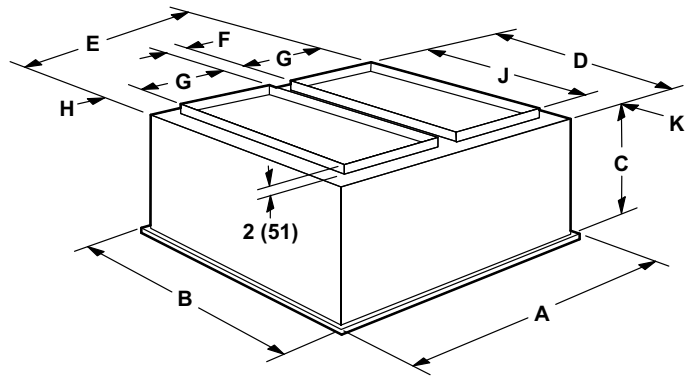

Model Number		RTD11-185	RTD11-275
A	in.	47-5/8	59-5/8
	mm	1210	1514
B	in.	47-5/8	59-5/8
	mm	1210	1514
C	in.	24-5/8	30-5/8
	mm	625	778
D	in.	45-1/2	57-1/2
	mm	1156	1461
E	in.	45-1/2	57-1/2
	mm	1156	1461
F	in.	4-1/2	4-1/2
	mm	114	114
G	in.	18	24
	mm	457	610
H	in.	2-1/2	2-1/2
	mm	64	64
J	in.	36	48
	mm	914	1219
K	in.	4-3/4	4-3/4
	mm	121	121
L	in.	45-1/2	57-1/2
	mm	1156	1461
M	in.	45-1/2	57-1/2
	mm	1156	1461
N	in.	10-1/8	11-1/8
	mm	257	283
Duct Size	in.	18 x 36	24 x 48
	mm	457 x 914	610 x 1219

Model Number		FD11-185	FD11-275
A	in.	47-5/8	59-5/8
	mm	1210	1514
B	in.	47-5/8	59-5/8
	mm	1210	1514
C	in.	29-1/4	35-1/4
	mm	743	895
D	in.	45	57
	mm	1143	1148
E	in.	45	57
	mm	1143	1448
F	in.	4-1/2	4-1/2
	mm	114	114
G	in.	18	24
	mm	457	610
H	in.	2-1/4	2-1/4
	mm	57	57
J	in.	36	48
	mm	914	1219
K	in.	4-1/2	4-1/2
	mm	114	114
Duct Size	in.	18 x 36	24 x 48
	mm	457 x 914	610 x 1219

SECTION 15730**UNITARY AIR CONDITIONING EQUIPMENT****PART 1 GENERAL****PART 1.01 SUMMARY**

- A. Section Includes: Packaged rooftop units and commercial packaged, gas/electric, electric/electric and electric/heat pumps.

Specifier Note: Revise paragraph below to suit project requirements. Add section numbers and titles per CSI *MasterFormat* and specifier's practice.

- B. Related Sections:

Specifier Note: Article below may be omitted when specifying manufacturer's proprietary products and recommended installation. Retain Reference Article when specifying products and installation by an industry reference standard. If retained, list standard(s) referenced in this section. Indicate issuing authority name, acronym, standard designation and title. Establish policy for indicating edition date of standard referenced. Conditions of the Contract or Division 1 References Section may establish the edition date of standards. This article does not require compliance with standard, but is merely a listing of references used. Article below should list only those industry standards referenced in this section. Retain only those reference standards to be used within the text of this Section. Add and delete as required for specific project.

PART 1.02 REFERENCES

- A. Agency Listings:
1. Intertek ETL.
 2. Canadian Standards Association (CSA).
- B. Safety Standards:
1. Underwriters Laboratories (UL).
 2. Underwriters Laboratories of Canada (ULC).
 3. National Electric Code (NEC).
 4. Canadian Electric Code (CEC).
- C. Air-Conditioning and Refrigerating Institute (ARI):
1. ARI 340/360 Commercial and Industrial Unitary Air-Conditioning and Heat Pump Equipment.
 2. ARI 370 Sound Rating of Large Outdoor Refrigerating and Air Conditioning Equipment.
 3. ARI 210/240 Performance Rating of Unitary Air Conditioning and Air-Source Heat Pump Equipment.
- D. American Society for Testing and Materials (ASTM):
1. ASTM B117 – Standard Practice for Operating Salt Spray.
 2. ASTM 1153 – Standard Method for Methyl Isobutyl Ketone.
- E. ISO 9001, Quality Management Systems.
- F. Meet Military Specification MIL-P-53084

Specifier Note: Article below should be restricted to statements describing design or performance requirements and functional (not dimensional) tolerances of a complete system. Limit descriptions to composite and operational properties required to link components of a system together and to interface with other systems.

PART 1.03 SYSTEM DESCRIPTION

- A. Performance Requirements:

Specifier Note: Article below should be restricted to T-Class (TH), heat pumps packaged roof top units only.

1. [2, 2.5, 3, 4, 5, 6, 7.5, 8.5, 10, 12.5, 15 and 20 ton capacity.]

Specifier Note: Article below should be restricted to T-Class (TG) gas/electric packaged roof top units or T-Class (TC) electric/electric packaged roof top units.

2. [2, 2.5, 3, 4, 5, 6, 7.5, 8.5, 10, 12.5, 15, 17.5, 20 and 25 ton capacity.]
3. Electrical Characteristics:
 - a. 60 Hz

Specifier Note: 208/230 volt 1 phase is only available on 2, 2.5, 3, 4 and 5 ton standard efficiency models. All other voltages are available on 3-25 ton T-Class RTU's.

- b. [208/230 v – 1 Phase] [208/230 v – 3 Phase] [460 v – 3 Phase] [575 v – 3 Phase]

Specifier Note: Article below includes submittal of relevant data to be furnished by Contractor before, during or after construction. Coordinate this article with Architect's and Contractor's duties and responsibilities in Conditions of the Contract and Division 1 Submittal Procedures Section.

PART 1.04 SUBMITTALS

- A. General: Submit listed submittals in accordance with Conditions of the Contract and Division 1 Submittal Procedures.
- B. Product Data: Submit product data for specified products.

GUIDE SPECIFICATIONS

- C. Shop Drawings:
1. Submit shop drawings in accordance with Section 01330 - Submittal Procedures.
 2. Indicate:
 - a. Equipment, piping and connections, together with valves, strainers, control assemblies, thermostatic controls, auxiliaries and hardware, and recommended ancillaries which are mounted, wired and piped ready for final connection to building system, its size and recommended bypass connections.
 - b. Piping, valves and fittings shipped loose showing final location in assembly.
 - c. Control equipment shipped loose, showing final location in assembly.
 - d. Dimensions, internal and external construction details, recommended method of installation with proposed structural steel support, mounting curb details, sizes and location of mounting bolt holes; include mass distribution drawings showing point loads.
 - e. Detailed composite wiring diagrams for control systems showing factory installed wiring and equipment on packaged equipment or required for controlling devices or ancillaries, accessories and controllers.
 - f. Fan performance curves.
 - g. Details of vibration isolation.
 - h. Estimate of sound levels to be expected across individual octave bands in dB.
 - i. Type of refrigerant used.
 - j. Plan view, front view end view, back view and curb detail with dimensions.
- D. Quality Assurance:
1. Test Reports: Certified test reports showing compliance with specified performance characteristics and physical properties.
 2. Certificates: Product certificates signed by manufacturer certifying materials comply with specified performance characteristics and criteria and physical requirements.
 3. Manufacturer's Instructions: Manufacturer's installation instructions.

Specifier Note: Coordinate paragraph below with Part 3 Field Quality Requirements Article herein. Retain or delete as applicable.

- E. Manufacturer's Field Reports: Manufacturer's field reports specified.
- F. Closeout Submittals: Submit following:
1. Warranty: Warranty documents specified.
 2. Operation and Maintenance Data: Operation and maintenance data for installed products in accordance with Division 1 Closeout Submittals (Maintenance Data and Operation Data) Section. Include methods for maintaining installed products and precautions against cleaning materials and methods detrimental to finishes and performance. Include names and addresses of spare part suppliers.
 3. Provide brief description of unit, with details of function, operation, control and component service.
 4. Provide equipment inspection report and equipment operation test report.
 5. Commissioning Report: Submit commissioning reports, report forms and schematics in accordance with Section 01810 - Commissioning.

PART 1.05 QUALITY ASSURANCE

- A. Qualifications:
1. Installer experienced in performing work of this section who has specialized in installation of work similar to that required for this project.

PART 1.06 DELIVERY, STORAGE & HANDLING

- A. General: Comply with Division 1 Product Requirements.
- B. Ordering: Comply with manufacturer's ordering instructions and lead time requirements to avoid construction delays.
- C. Packing, Shipping, Handling and Delivery:
1. Deliver materials in manufacturer's original, unopened, undamaged containers with identification labels intact.
 2. Ship, handle and unload units according to manufacturer's instructions.
- D. Storage and Protection:
1. Store materials protected from exposure to harmful weather conditions.
 2. Factory shipping covers to remain in place until installation.

PART 1.07 PROJECT CONDITIONS

- A. Installation Location: **[Confirm design conditions and temperature.]**

Specifier Note: Coordinate article below with Conditions of the Contract and with Division 1 Closeout Submittals (Warranty).

PART 1.08 WARRANTY

- A. Project Warranty: Refer to Conditions of the Contract for project warranty provisions.
- B. Manufacturer's Warranty: Submit, for Owner's acceptance, manufacturer's standard warranty document executed by authorized company official. Manufacturer's warranty is in addition to, and not a limitation of, other rights Owner may have under Contract Documents.

GUIDE SPECIFICATIONS

Specifier Note: “Aluminized Heat Exchanger” and “Stainless steel Heat Exchanger” limited warranty is only available on T-Class (TG) Gas/Electric models. “Compressor” and “Other System Components” are covered on all T-Class units.

- C. Warranty: Commencing on Date of Installation.
 - 1. Compressors: 5 years (limited).
 - 2. Other Covered System Components: 1 year (limited).
 - 3. [Aluminized Heat Exchangers: 10 years (limited).] [Stainless Steel Heat Exchangers: 15 years (limited).]

PART 2 PRODUCTS

Specifier Note: Retain article below for proprietary method specification. Add product attributes, performance characteristics, material standards and descriptions as applicable. Use of such phrases as “or equal” or “or approved equal” or similar phrases may cause ambiguity in specifications. Such phrases require verification (procedural, legal and regulatory) and assignment of responsibility for determining “or equal” products.

PART 2.01 ROOFTOP UNITS

- A. Manufacturer: Lennox Industries.
 - 1. Contact: 2100 Lake Park Blvd., Richardson, TX 75080; Telephone: (800) 453-6669; website: www.lennox.com.
- B. Proprietary Products/Systems: Lennox T-Class Packaged Rooftop Units, including the following equipment:
 - 1. Cabinet:
 - a. Heavy gauge steel panels.
 - b. Pre-painted steel panels.
 - c. Heavy Gauge galvanized steel base rail.
 - d. Rigging holes on all four corners.
 - e. Forklift slots (on three sides, not directly below condenser coil) on base rail.
 - f. Raised or flanged edges around duct and power entry openings.

Specifier Note: “Down Flow” is the standard configuration that all T-Class units are shipped as.

Specifier Note: “Horizontal Flow” is an option for all T-Class models. T-Class TH, TG and TC models of tonnages 2, 2.5, 3, 4, 5 and 6 can be converted, in the field, to horizontal flow without the need of a conversion kit. If applied horizontally with an economizer, a conversion kit is required.

Specifier Note: “Horizontal Flow” is an option for all T-Class models. T-Class TH, TG and TC models of tonnages 7.5, 8.5, 10 and 12.5 can be converted, in the field, with a separate to Horizontal Conversion Kit.

Specifier Note: “Horizontal Flow” is an option for all T-Class models. T-Class TH, TG and TC models of tonnages 15, 17.5, 20 and 25 require a roof curb that allows for horizontal air flow. A Horizontal Air Panel Kit is also required if converting a down-flow configured unit to horizontal air flow.

- g. [Down-Flow] [Horizontal] Air Flow configuration

Specifier Note: add the “and gas lines” only if using a T-Class (TG) gas/electric model.

- h. Electrical lines [and gas lines] can be brought through the base of the unit or through horizontal knockouts.
- i. Insulation:
 - 1) All panels adjacent to conditioned air are fully insulated with non-hygroscopic fiberglass insulation.
 - 2) Unit base is fully insulated.
 - 3) Unit base insulation also serves as a roof curb seal.
- j. Access Panels:
 - 1) Provided for economizer/filter section.
 - 2) Provided for Heating/blower section.
- k. Condensate Drain Pan.

Specifier Note: “Factory Installed Options” are options that can be selected for the T-Class roof top units. The “Factory Installed Options” are installed at the Lennox manufacturing facility.

- l. [Factory Installed Options:]
 - 1) [Corrosion Protection, meets standards:
 - a) Military Specification MIL-P-53084.
 - b) ASTM B117
 - c) ASTM 1153]
 - 2) [Hinged Access panels]
 - 3) [GFI Service Outlets (field wired)]

Specifier Note: “Field Installed Accessories” are options that can be selected for the T-Class roof top units. The “Field Installed Accessories” are shipped separately and installed in the field.

- m. [Field Installed Accessories:]

GUIDE SPECIFICATIONS

Specifier Note: Of the selections below, [Coil Guards] [Hail Guards], only one can be selected.

- 1) [Coil Guards] [Hail Guards].
- 2) [Horizontal Return Air Panel Kit].

Specifier Note: "Circuit Breakers(up to 175 amps)" is not available on 2-6 ton models.

- 3) [Circuit Breakers (up to 175 amps)]
 - 4) [Disconnect Switch (up to 250 amps)]
 - 5) [Condensate drain trap]
2. Cooling System:
- a. Capable of operating from 30 - 125 degrees F (-1 - 52 degrees C) without installation of additional controls.
 - b. Compressors:

Specifier Note: The TG/TC036B unit uses a reciprocating compressor instead of a scroll type.

- 1) Scroll Type.
 - 2) Resiliently mounted on rubber mounts for vibration isolation.
 - 3) Overload Protected
 - 4) Internal excessive current and temperature protection.
 - 5) Isolated from condenser fan air stream.
 - 6) Refrigerant cooled.
- c. TXV
 - d. Freezestat
 - e. High capacity filter driers

Specifier Note: Include following 2 articles for T-Class (TH) packaged heat pumps models.

- f. Reversing Valves: Four-way interchange reversing valve.
- g. Defrost Control.

Specifier Note: 2-2.5 ton models are only available in Standard efficiency, 3-6 ton models are available in Basic or Standard efficiencies only, and 7.5-20 ton models are available in Standard or High efficiencies only.

Specifier Note: The 12.5 ton model is available in standard efficiency only.

- h. Efficiency: [Basic] [and]/[or] [Standard] [and]/[or] [High].
- i. [Low ambient kit: Field installed]

Specifier Note: High pressure switch is available to be field installed on all units except the T-Class model TH on tonnages 15-20.

- j. [High pressure switch: Field installed]

Specifier Note: Crankcase heater is available to be field installed on all units except the T-Class model TH on tonnages 2-6 and 15-20.

- k. [Crankcase heater: field installed]
3. Coil Construction:
- a. Condensing/evaporator coil general construction:
 - 1) Aluminum Rippled and Lanced fins.
 - 2) Copper tube construction.
 - 3) Aluminum fins mechanically bonded to copper tubes.
 - 4) All coils are high pressure leak tested at manufacturing facility.
 - b. Evaporator Coils:
 - 1) With balanced port thermal expansion valves, freeze protection on each compressor circuit, pressure and leak tested to 500 psi, and maximum 14 fins per inch.
 - 2) Each compressor circuit on coil divided across face of coil and active through full depth of coil.
 - 3) [With flexible immersed coating electrodeposited by dry film process].
 - c. Condenser Coils:
 - 1) [With flexible immersed coating electrodeposited by dry film process] on corrosion hardened units only.

GUIDE SPECIFICATIONS

4. Wiring:
 - a. Color coded and continuously marked to identify point-to-point component connections.
 - b. Not in contact with hot-gas refrigerant lines or sharp metal edges.
5. Cooling Controls:
 - a. Provide minimum compressor on time of 4 minutes.

Specifier Note: “4 Stages of cooling from thermostat” is only available for models that have 4 independent refrigerant circuits. 2-6 ton models have 1 circuit, 7.5-12.5 ton models have 2 circuits, and 15-25 ton models have several models with 4 circuits.

- b. Support up to 4 stages of cooling from thermostat or external DDC controller. (4 independent refrigerant circuits required.)

Specifier Note: T-Class units with Gas Heating Systems are TG models.

6. Gas Heating System:
 - a. Induced draft
 - b. Natural gas fired system with direct spark ignition
 - c. Electronic flame sensors
 - d. Flame rollout switches
 - e. High heat limit switches
 - f. Induced draft failure switch and capable of operating to altitude of 2000 feet (610 m) with no derate to manifold pressure.
 - g. Service access for controls, burners and heat exchanger.
 - h. Heat Exchanger:
 - 1) Tubular Design
 - 2) **[Aluminized steel] [Stainless steel].**
 - i. Gas piping system tight and free of leaks when pressurized to maximum supply pressure.
 - j. Gas Valve: Two-stage, redundant type gas heat valve with manual shutoff.

Specifier Note: One Stage Gas valve only available on 2-6 ton models.

- k. Gas Valve: Single-stage.
 - l. Gas Burners: Aluminized steel inshot-type gas burners.
 - m. Direct spark pilot ignition.
 - n. Fan and Limit Controls.
 - o. Safety Switches.
 - p. Gas piping system tight and free of leaks when.

Specifier Note: “Cold Weather Kit” is only available for field mounting on the T-Class (TG) Gas/Electric models of tonnages 15 – 25 or factory mounting on the T-Class (TG) Gas/Electric models of tonnages 7.5 – 12.

- q. **[Cold Weather Kit:] [field] [factory]**

Specifier Note: “Field Installed Accessories” are options that can be selected for the T-Class TG Gas/Electric models. The “Field Installed Accessories” are shipped separately and installed in the field.

- r. **[Field Installed Accessories:]**
 - 1) **[Combustion Air Intake Extensions].**
 - 2) **[Vertical Vent Extension Kit].**
 - 3) **[LPG/Propane Kit].**

Specifier Note: “Low Temperature Vestibule Heater” is only available for the T-Class (TG) Gas/Electric models of tonnages 2, 2.5, 3, 4, 5 and 6.

- 4) **[Low Temperature Vestibule Heater].**

Specifier Note: The “Electric Heating System” is an option for T-Class (TH), heat pump, and T-Class (TC), electric/electric models only. The “Electric Heating System” can be either factory or field installed.

7. Electric Heating System:
 - a. Electrical resistance heater.
 - b. **[Factory] [Field] installed.**
 - c. **[Factory] [Field] installed Fuse Block.**
 - d. Reset thermal limit protection.
 - e. Single point power supply.
 - f. Heater Element:
 - 1) Nickel chromium wire.
 - 2) Individually fused.

GUIDE SPECIFICATIONS

- g. Electric heater slides out of unit for service.
- 8. Heating Controls:

Specifier Note: 2 stages of heating control are only available on T-Class (TG) gas/electric models of tonnages 4-6, on two stage units.

- a. Support 2 stages of heating control from thermostat or DDC.
- b. With delay time of 30 seconds between low and high heat stages.
- 9. Supply Air Fan Motor and Drives:
 - a. Permanently lubricated ball bearings (for belt drive motors).
 - b. Thermal overload protected motors with automatic reset.

Specifier Note: Slide out accessibility is only available on T-Class models of tonnages 7.5-25.

- c. Adjustable sheaves on belt drive motors for blower speed adjustment.
- d. Optional low and high static motor/drive combinations and optional drive kits.
- 10. Supply Air Fan:
 - a. Double inlet type, G90 (Z275) galvanized steel with forward curved blades.
 - b. Statically and dynamically balanced.
 - c. Slide-out accessibility unit for servicing and belt tension adjustment.
 - d. Continuous or automatic control for occupied periods.
- 11. Supply Air Filters:
 - a. Disposable 2 inch.

Specifier Note: Permanent metal frame filters with 2 inch polyester replaceable media are only available on T-Class models of tonnages 15-25 tons.

- b. [Permanent metal frame filters with 2 inch polyester replaceable media].
- 12. Condenser Fan Motor:

Specifier Note: T-Class 2-4 ton models have sleeve bearings.

- a. Direct drive with permanently lubricated ball bearings.
- b. Watertight with thermal overload protection and automatic reset.
- c. Motor mount isolated from fan safety guard.
- 13. Condenser Fans:
 - a. Corrosion resistant propeller type with vertical discharge and finger safety guard.
- 14. Microprocessor Based Unit Controller System:
 - a. Solid state, microprocessor based control board to control unit cooling operations.
 - b. Green blinking LED to indicate normal operation.
 - c. Pushbutton reset.
 - d. Four-position DIP switch to select unit operating mode/unit type.
 - e. Test mode for quick operation checks.
 - f. Up to 2-stage heat/4-stage cool thermostat or DDC capable thermostat operation.
 - g. Digital Inputs:
 - 1) Low cool demand
 - 2) High cool demand
 - 3) Low heat demand
 - 4) Supply fan demand
 - 5) Primary heat limit (2)
 - 6) Flame rollout switch (2)
 - 7) Induced draft motor switch (2)
 - 8) Gas valve sense switch (2)

Specifier Note: T-Class models of tonnages 15-25 have four Freeze protection switches. 7.5 - 12 ton models have two. 2-6 ton models have one.

- 9) Freeze protection switch (2), (4).
- h. Digital Outputs:
 - 1) Supply air fan motor
 - 2) compressor 1
 - 3) compressor 2
 - 4) condenser fans
 - 5) inducer fan motor 1

Specifier Note: T-Class 7.5 - 25 ton models only.

GUIDE SPECIFICATIONS

- 6) heat 1
- 7) critical diagnostic fault code occurrence.

i. **[Control Options:]**

- 1) **[Single Enthalpy Control] : [Field] [Factory]**
- 2) **[Differential Enthalpy Control : Field]**

Specifier Note: The factory mounted CO2 sensor is only available T-Class models of tonnages 15 - 25. All other models can be field mounted only.

- 3) **[CO2 Sensor:] [Field] [Factory]**

Specifier Note: Economizer Control: Field is only available for T-Class models of tonnages 7.5 - 25.

- 4) **[Economizer Control: Field]**

15. **[Accessories:]**

- a. **[Economizer]: [Field] [Factory]**

Specifier Note: Motorized outdoor air damper is only available in a field mounted version for the T-Class models of tonnages 2, 2.5, 3, 4, 5 and 6. All other models can be factory or field.

- b. **[Motorized outdoor air damper]: [Field] [Factory]**

Specifier Note: Manual outdoor air damper is only available in a field mounted version for the T-Class models of tonnages 2, 2.5, 3, 4, 5 and 6. All other models can be factory or field.

- c. **[Manual outdoor air damper]: [Field] [Factory]**

Specifier Note: Barometric relief damper is included with factory or field installed economizer on 2-6 ton models. All other models can be factory or field installed separately.

- d. **[Barometric relief damper]: [Field] [Factory]**

Specifier Note: The factory mounted Power Exhaust Fan is only available on the versions of T-Class models of tonnages 15-25. All other models can be field mounted.

- e. **[Power exhaust fan]: [Field] [Factory]**

- f. **[Dirty filter switch: Field]**

Specifier Note: The field mounted Blower Proving Switch is only available on T-Class models of tonnages 7.5-25.

- g. **[Blower proving switch]: [Field] [Factory]**

- h. **[Smoke detectors: Field]**

- i. **[Roof curb: Field]**

- j. **[Outdoor air hood: Field]**

- k. **[Barometric relief damper hood: Field]**

Specifier Note: Edit article below to suit project requirements. If substitutions are permitted, edit text below. Add text to refer to Division 1 Project Requirements (Product Substitutions Procedures) Section.

PART 2.02 PRODUCT SUBSTITUTIONS

- A. Substitutions: No substitutions permitted.

PART 3 EXECUTION

PART 3.01 MANUFACTURER'S INSTRUCTIONS

Specifier Note: Revise article below to suit project requirements and specifier's practice.

- A. Compliance: Comply with manufacturer's written data, including product technical bulletins, product catalog installation instructions, product carton installation instructions and manufacturer's SPEC-DATA® sheets.

PART 3.02 EXAMINATION

- A. Site Verification of Conditions: Verify substrate conditions, which have been previously installed under other sections, are acceptable for product installation in accordance with manufacturer's instructions

PART 3.03 INSTALLATION

- A. Install **[Packaged rooftop units] [And] [Commercial packaged, gas/electric, electric/electric and electric/heat pumps]** in accordance with manufacturer's instructions **[On roof curbs provided by manufacturer] [As indicated]**.

END OF SECTION

REVISIONS

Sections	Description of Change
Dimensions	Updated Diffuser dimension drawings.
Optional Accessories	Updated Information - High Pressure Switches, Low Ambient Kit and Horizontal 37 in. Roof Curb.
Sound Data	Octave Band Sound Power Levels updated.



VERIFIED
ENERGY
PERFORMANCE



VERIFIE
RENDEMENT
ENERGETIQUE



Visit us at www.lennox.com

For the latest technical information, www.lennoxcommercial.com

Contact us at 1-800-4-LENNOX

NOTE - Due to Lennox' ongoing commitment to quality, Specifications, Ratings and Dimensions subject to change without notice and without incurring liability. Improper installation, adjustment, alteration, service or maintenance can cause property damage or personal injury. Installation and service must be performed by a qualified installer and servicing agency.

©2008 Lennox Industries Inc.