



Bulletin No. 210392
July 2008
Supersedes August 2007



ASHRAE 90.1
COMPLIANT



7.5 to 12.5 Tons
Net Cooling Capacity - 90,000 to 138,000 Btuh
Gas Input Heat Capacity - 84,500 to 240,000 Btuh

MODEL NUMBER IDENTIFICATION

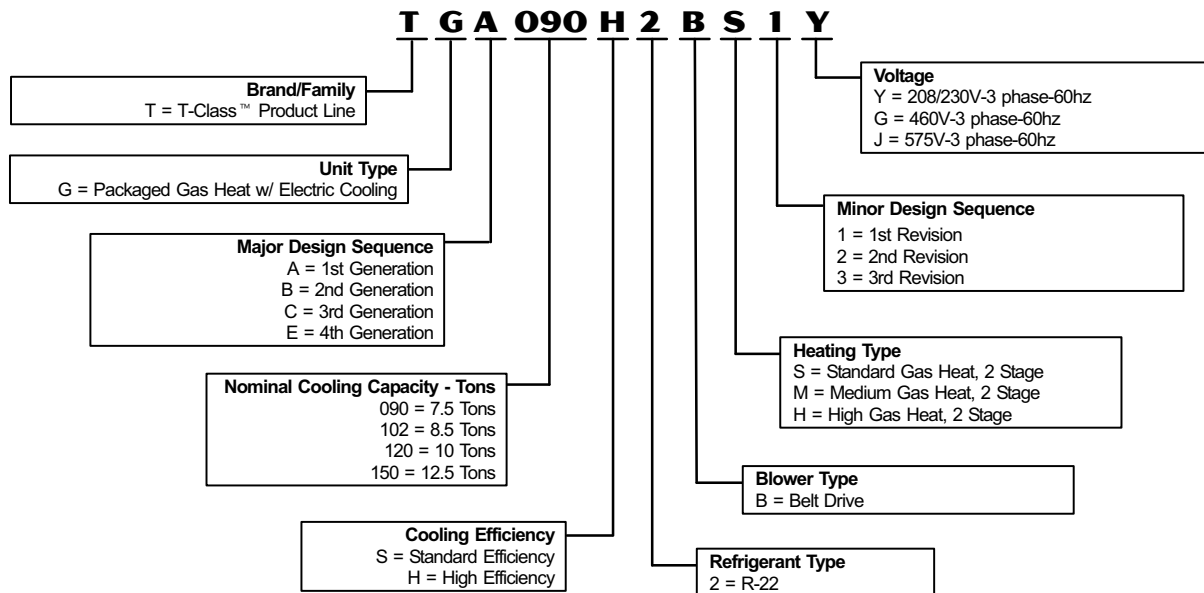

TABLE OF CONTENTS

Blower Performance	Page 16-18
Cooling Ratings	Pages 12-15
Dimensions	Pages 23-28
Electrical Data	Pages 18-20
Features and Benefits	Pages 2-4
Guide Specifications	Pages 29-35
High Altitude Information	Page 11
Installation Clearances	Page 20
Model Number Identification	Page 1
Optional Accessories	Pages 5-8
Specifications	Pages 9-10
Sound Data	Page 15
Temperature Control Systems	Page 21
Weights	Page 22

FEATURES AND BENEFITS

APPROVALS

ETL and CSA listed. Components bonded for grounding to meet safety standards for servicing required by UL, CSA and National and Canadian Electrical Codes. Gas efficiency ratings verified by CSA. Cooling performance certified in accordance with the ULE certification program, which is based on ARI Standard 340/360-2000.

ENERGY STAR® certified units are designed to use less energy, help save money on utility bills, and help protect the environment.

The ENERGY STAR® Partner of the Year Award signifies that Lennox has made outstanding contributions to design energy efficient units that will lower energy bills, while meeting industry standards for comfort and indoor air quality. Lennox was the first HVAC manufacturer to win this award and has been a four-time recipient since 2003. ISO 9001 Registered Manufacturing Quality System.

WARRANTY

Limited ten years on aluminized steel heat exchanger.

Limited five years on compressors.

Limited one year all other covered components.

HEATING SYSTEM

- Aluminized steel inshot burners, direct spark ignition, electronic flame sensor, combustion air inducer, redundant automatic dual-stage gas valve with manual shut-off.

Heat Exchanger

Tubular construction, aluminized steel, life cycle tested.

Stainless Steel Heat Exchanger is required if mixed air temperature is less than 45°F.

Fan & Limit Controls

Factory installed with fixed temperature setting.

Heat limit controls protect against overheating.

Safety Switches

Flame roll-out switches, flame sensors and combustion air inducer proving switches protect system operation. All safety switches are monitored by the ignition control board.

Electronic Ignition

Solid-state electronic spark igniter provides positive direct ignition of burners on each operating cycle. The system permits main gas valve to stay open only when the burners are proven to be lit. Should a loss of flame occur, the gas valve closes, shutting off the gas to the burners. Ignition module has LED to indicate status and aid in troubleshooting.

Watchguard circuit on module automatically resets ignition controls after one hour of continuous thermostat demand after unit lockout, eliminating nuisance service calls. Ignition control is factory installed in the controls section.

REQUIRED SELECTIONS

Gas Input - Order one (see Specification table for available sizes):

84,500/130,000 Btuh Standard Heat Gas Input.

117,000/180,000 Btuh Medium Heat Gas Input

156,000/240,000 Btuh High Heat Gas Input.

OPTIONS/ACCESSORIES

Factory Installed

Stainless Steel Heat Exchanger

Required if mixed air temperature is below 45°F.

Optional Heat Size

Extends heat input beyond standard offering.

Cold Weather Kit

Electric heater automatically controls minimum temperature in gas burner compartment when temperature is below -40°F CSA certified to allow operation of unit down to -60°F.

Field Installed

Combustion Air Intake Extensions

Recommended for use with existing flue extension kits in areas where high snow drifts can block intake air.

LPG/Propane Kits

Conversion kit to field change over units from Natural Gas to LPG/Propane.

Vertical Vent Extension Kit

Exhausts flue gases vertically above unit.

Through Mullion Gas Piping Kit

The gas piping kit is used to make gas piping connections from the unit mullion to the gas valve.

Unit Base Gas Piping Kit

The gas piping kit is used to make gas piping connections through the unit base up to the mullion.

NOTE - For gas piping from the unit base to the gas valve, both kits are required and must be ordered separately.

FEATURES AND BENEFITS

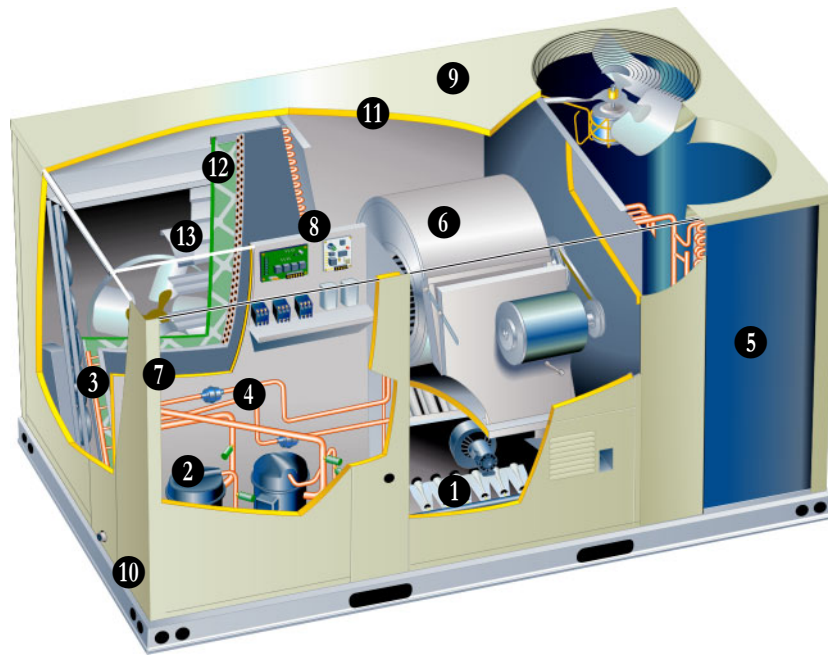

COOLING SYSTEM

Designed to maximize sensible and latent cooling performance at design conditions. Two efficiency levels provide flexibility. System can operate from 30°F to 125°F without any additional controls.

2 Compressors

Resiliently mounted on rubber grommets for quiet operation. Scroll compressors on all models for high performance, reliability and quiet operation.

3 Thermal Expansion Valves

Assures optimal performance throughout the application range. Removable element head.

4 Filter/Driers

High capacity filter/driers protect the system from dirt and moisture.

Freezestats

Protects the evaporator coil from damaging ice build-up due to conditions such as low/no air flow, or low/no refrigerant charge.

5 Coil Construction

Copper tube construction, enhanced rippled-edge aluminum fins, flared shoulder tubing connections, silver soldered construction for improved heat transfer. Factory leak tested.

Evaporator Coil

Face split with separate circuits. Each circuit has its separate expansion valve, compressor and refrigerant charge. Enhanced aluminum fins and copper tube coils with cross row circuiting optimizes both sensible and latent cooling capacity.

Condenser Coil

Formed type on all models. Ripple-edged, enhanced aluminum fin and copper tube construction maximizes heat transfer capability.

Condensate Drain Pan

Painted, galvanized pan with positive slope. Drain connection extends outside unit.

Outdoor Coil Fan Motors

Thermal overload protected, totally enclosed, permanently lubricated ball bearings, shaft up, independent motor mount.

Outdoor Coil Fan

PVC coated fan guard furnished.

REQUIRED SELECTIONS

Cooling Capacity

Specify the nominal cooling capacity of the unit.

Cooling Efficiency

Specify either standard or high efficiency.

OPTIONS/ACCESSORIES

Field Installed

Condensate Drain Trap

Available in copper or PVC.

Compressor Crankcase Heaters

Protects against refrigerant migration that can occur during low ambient operation.

High Pressure Switches

Protects the compressor from overload conditions such as dirty condenser coils, blocked refrigerant flow, or loss of outdoor fan operation. Manual reset.

Low Ambient Kit

Cycles the outdoor fan while allowing compressor operation in the cooling cycle. This intermittent fan operation allows the system to operate without icing the evaporator coil and losing capacity. Designed for use in ambient temperatures no lower than 0°F.

6 BLOWER

Supply air fan provides a wide range of air flow capability. Special order high and low static motor and drive options are available offering an even wider range of capability.

Supply Air Motor

Overload protected with permanently lubricated ball bearings ensures durable operation. Belt drive motors that meet EPACT efficiency requirements maximize air performance and save energy. Special order high and low static motors provide a higher level of air performance for demanding applications.

Supply Air Blower

A double inlet wheel with forward curve blades provide maximum air performance and quiet operation. Dynamically balanced with permanently lubricated ball bearings assure long, reliable operation. Adjustable pulleys allow air to be precisely tuned to the needs of the application.

REQUIRED SELECTIONS

Supply Air Blower

Specify Blower motor and drive kit (See Blower Data Table for specifications).

OPTIONS/ACCESSORIES

Factory Installed

High and Low Static Supply Fan

Extends air flow external static range.

FEATURES AND BENEFITS

ELECTRICAL

REQUIRED SELECTIONS

Voltage Choice

Specify 208/230V, 460V or 575V 3-phase-60hz when ordering base unit.

OPTIONS/ACCESSORIES

Field Installed

7 Circuit Breakers up to 175 Amp

HACR circuit breaker without power distribution lugs. Accessible from outside of unit, spring-loaded weatherproof cover furnished. Main power to the unit is field connected to the circuit breaker which allows all power to be shutoff for service. Circuit breaker is sized to the unit maximum overcurrent protection (MOCP) size.

Disconnect Switch up to 250 Amp

Accessible from outside of unit, spring loaded weatherproof cover furnished. Main power to the unit is field connected to the disconnect which allows all power to be shut off for service.

GFI Service Outlets (2)

115v ground fault circuit interrupter (GFCI) type, field wired.

CONTROLS

8 Unit Controller

Microprocessor-based control board provides flexible control of cooling functions. All control voltage is provided via a 24V (secondary) transformer with built-in circuit breaker protection. Built-in functions include:

Blower On/Off Delay - Time delay between blower on and off cycles provides a more even supply air temperature during heating.

Built-in Control Parameters - Saves installation time as no programming is required.

Minimum Compressor Run Time - Ensures proper oil return to the compressor.

Night Setback Mode - Saves energy by closing outdoor air dampers and operating supply fan on thermostat demand only.

Heat/Cool Staging - Capable of up to 2 heat / 2 cool staging with a third party DDC control system or compatible thermostat.

Thermostat Bounce Delay - Protects compressor from short cycling when a mechanical thermostat is used.

OPTIONS/ACCESSORIES

Field Installed

Blower Proving Switch

Uses a static pressure sensor to monitors blower operation and shuts down unit if blower fails.

Dirty Filter Switch

Senses static pressure increase indicating dirty filter condition.

Smoke Detector

Photoelectric type, installed in supply air section or return air section or both sections

Commercial Control Systems

L Connection® Network

Complete building automation control system for single or multi-zone applications. Options include local interface, software for local or remote communication, and hardware for networking other control functions. See L Connection Network Engineering Handbook Bulletin for details.

Thermostats

Control system and thermostat options. Aftermarket unit controller options. See See Page 21.

CABINET

9 Construction

Heavy-gauge steel panels and full perimeter heavy-gauge galvanized steel base rail provides structural integrity for transportation, handling, and installation. Base rails have rigging holes. Three sides of the base rail have fork slots. Raised edges around duct and power entry openings in the bottom of the unit provide additional protection against water entering the building.

Air-Flow Choice

Units are available in down-flow (vertical) or horizontal air flow configuration with optional field installed Horizontal Conversion Kit.

Duct Flanges

Horizontal supply duct flange is standard on all units.

10 Power/Gas Entry

Electrical and gas lines can be brought through the unit base or through horizontal access knock-outs.

Exterior Panels

Constructed of heavy-gauge, galvanized steel with a two-layer enamel paint finish. Large removable panels provide service access.

11 Insulation

All panels adjacent to conditioned air are fully insulated with non-hygroscopic fiberglass insulation. Unit base is fully insulated. The insulation also serves as an air seal to the roof curb, eliminating the need to add a seal during installation.

Access Panels

Access panels are provided for the economizer/filter section, blower section, heating section and the compressor/controls section.

REQUIRED SELECTIONS

Air Flow Configuration

Specify horizontal or down-flow (vertical).

OPTIONS/ACCESSORIES

Factory Installed

Corrosion Protection

A completely flexible immersed coating with an electrodeposited dry film process. (AST ElectroFin E-Coat) Meets Mil Spec MIL-P-53084, ASTM B117 Standard Method Salt Spray Testing, ASTM 1153 Standard Specification for Methyl Isobutyl Ketone.

Hinged Access Panels

Large access panels are hinged and have quarter-turn latches for quick and easy access to maintenance areas (economizer / filter, compressor / controls, heating / blower).

Field Installed

Coil Guards

Painted, galvanized steel wire guards to protect outdoor coil. Not used with Hail Guards.

Hail Guards

Constructed of heavy gauge steel, painted to match cabinet, helps protect outdoor coils from hail damage. Not used with Coil Guards.

Horizontal Return Air Panel Kit

Required for horizontal applications with Horizontal Roof Curb, contains panel with return air opening for field replacement of existing unit panel and panel to cover bottom return air opening in unit, see dimension drawings.

FEATURES AND BENEFITS

INDOOR AIR QUALITY

12 Air Filters

Disposable 2 inch filters furnished as standard.

OPTIONS/ACCESSORIES

Field Installed

Indoor Air Quality (CO₂) Sensor

Monitors CO₂ levels.

SERVICEABILITY

Designed to streamline general maintenance and decrease troubleshooting time.

Marked & Color-Coded Wiring

All electrical wiring is color-coded and marked to identify which components it is connecting.

Electrical Plugs

Positive connection electrical plugs are used to connect common accessories or maintenance parts for easy removal or installation.

Access Panels

Large access panels are provided for quick and easy access to maintenance areas.

Blower Access

Blower assembly slides out of the unit for easy access.

TXV Access

Thermal expansion valves are located near the perimeter of the unit for easier access.

Thermal Expansion Valves

Removable element head allows change out of element and bulb without removing the TXV.

Coil Cleaning

Independently formed condenser coils allow separation for easier cleaning.

Standard Components

A large number of common maintenance parts are standard throughout the entire range of sizes (7.5 - 12.5 tons), reducing the need to carry a lot of different parts to the job or in inventory.

Compressor Access

Compressors are located near the perimeter of the unit for easier access.

Compressor Compartment

Compressors are isolated from the condenser air flow allowing system operation checks to be done without changing the air flow across the outdoor coils.

OPTIONS / ACCESSORIES

ECONOMIZER/OUTDOOR AIR/EXHAUST ACCESSORIES

Factory or Field Installed

13 Economizer

Parallel, gear-driven action return air and outdoor air dampers, plug-in connections to unit, nylon bearings, neoprene seals, 24 volt, spring return motor, adjustable minimum damper position, damper assembly slides in unit, outdoor air hood must be ordered separately, choice of economizer controls. Economizer modulates dampers to maintain a 55°F discharge air temperature.

Economizer Enthalpy Control

Senses outdoor air enthalpy and enables economizer if the enthalpy is less than the setpoint of the control.

Down-Flow Barometric Relief Dampers

Allows relief of excess return air static when economizer is near full open. Aluminum blade dampers prevent blow back and outdoor air infiltration during off cycle. Bird screen furnished.

Outdoor Air Damper Section

25% Manual Outdoor Air Dampers - Parallel blade dampers are manually adjustable to a fixed position.

25% Automatic Outdoor Air Damper - Parallel blade, gear-driven dampers are automatically adjusted with a two-position damper motor.

Economizer and Outdoor Air Damper

Application Note - Minimum mixed air temperature in heating mode 30°F
Maximum mixed air temperature in cooling mode: 90°F

Power Exhaust Fans

Installs internal to unit for down-flow applications with economizer option. Provides exhaust air pressure relief. Interlocked to run when supply air blower is operating. Fan runs when outdoor air dampers are 50% open (adjustable). Motor is overload protected. Galvanized steel cabinet and hood painted to match unit. Total air volume is 4200 cfm at 0 in. wg. 1/3 hp motor. 300 Watts total input. See Power Exhaust Blower Tables.

Field Installed

Economizer Control

Sensible Temperature Control - Senses outdoor air temperature and enables the economizer if the temperature is less than the set point of the control. Order two kits for differential control.

Single Outdoor Enthalpy Control - Senses outdoor air enthalpy and enables economizer if the enthalpy is less than the setpoint of the control.

Differential Enthalpy (Dual) Control - Two solid-state enthalpy sensors allow the control to select between outdoor air or return air, whichever has lower enthalpy.

Outdoor Air Hood

Required with Economizer, Outdoor Air Damper Sections, cleanable aluminum mesh fresh air filters furnished.

Down-Flow Barometric Relief Damper Hood

Protects exhaust air from recirculating into outdoor air stream.

Horizontal Barometric Relief Dampers

Allows relief of excess air when economizer is near full open. Aluminum blade dampers prevent blow back and outdoor air infiltration during off cycle. Field installed in return air duct. Bird screen furnished.

CEILING DIFFUSERS

OPTIONS/ACCESSORIES

Field Installed

Ceiling Diffusers

Aluminum grilles, large center grille, insulated diffuser box with flanges, hanging rings furnished, interior transition (even air flow), internally sealed (prevents recirculation), adapts to T-bar ceiling grids or plaster ceilings.

Transitions (Supply and Return) - Used with diffusers, installs in roof curb, galvanized steel construction, flanges furnished for duct connection to diffusers, fully insulated.

ROOF CURBS

OPTIONS/ACCESSORIES

Field Installed

Nailer strip furnished, mates to unit, US National Roofing Contractors Approved, shipped knocked down. Available in 8, 14, 18, and 24 inch heights.

Cliplock curbs use interlocking tabs to fasten together. No tools required.

Standard roof curb corners fasten together with furnished hardware.

OPTIONS / ACCESSORIES

Item	Catalog No.	090	102	120	150	
COOLING SYSTEM						
Compressor Crankcase Heater	208/230V - TACHK10/15-Y	76M34	x	x	x	x
	460V - TACHK10/15-G	76M35	x	x	x	x
	575V - TACHK10/15-J	76M36	x	x	x	x
Condensate Drain Trap	PVC - LTACDKP09/36	37K90	x	x	x	x
	Copper - LTACDKC09/36	48K14	x	x	x	x
Efficiency	Standard		○	○	○	○
	High		○	○	○	
High Pressure Switch	T1SNSR11B-2	42W97	x	x	x	x
Low Ambient Kit	T1SNSR12B-2	42W98	x	x	x	x
Refrigerant Type	R-22		○	○	○	○
HEATING SYSTEM						
Cold Weather Kit	Factory		○	○	○	○
Combustion Air Intake Extensions	LTACA1K10/15	89L97	x	x	x	x
Gas Heat Input	Standard - 130 kBtuh input		○	○	○	○
	Medium - 180 kBtuh input		○	○	○	○
	High - 240 kBtuh input		○	○	○	○
Gas Piping Kit 1 Order one of each	Through Mullion - LTAGPSK10/15	76M16	x	x	x	x
	Through Unit Base - LTAGPB10/15	76M17	x	x	x	x
LPG/Propane Kit	130 kBtuh input - LTALPGK-130	72M94	x	x	x	x
	180 kBtuh input - LTALPGK-180	72M95	x	x	x	x
	240 kBtuh input - LTALPGK-240	72M96	x	x	x	x
Stainless Steel Heat Exchanger			○	○	○	○
Vertical Vent Extension	LTAWEK10/15	73M72	x	x	x	x
BLOWER - SUPPLY AIR						
Constant Air Volume	2 hp Standard or High Efficiency		○	○	○	
	3 hp Standard Efficiency		○	○	○	○
	3 hp High Efficiency		○	○	○	○
	5 hp Standard or High Efficiency				○	○
CABINET						
Coil Guards	TACGKC10/15	69M44	x	x	x	x
Corrosion Protection			○	○	○	○
Hail Guards	TAHGKGC10/15	69M45	x	x	x	x
Hinged Access Panels			○	○	○	○
Horizontal Discharge Conversion Kit	LTHSDKGC10/15	56K53	x	x	x	x

NOTE - The catalog and part numbers that appear here are for ordering field installed accessories only.

○ - Configure to Order (Factory Installed)

x - Field Installed.

¹ For gas piping from the unit base to the gas valve, both kits are required and must be ordered separately.

OPTIONS / ACCESSORIES

Item	Catalog No.	090	102	120	150
CONTROLS					
Blower Proving Switch	C0SWCH01AE1- 30K49	x	x	x	x
Dirty Filter Switch	C0SWCH00AE1- 30K48	x	x	x	x
Smoke Detector - Supply	LTASASDK10/36 70K87	x	x	x	x
Smoke Detector - Return	LTRASDK-10/30 70K86	x	x	x	x
ELECTRICAL					
Voltage 60 hz	208/230V - 3 phase	○	○	○	○
	460V - 3 phase	○	○	○	○
	575V - 3 phase	○	○	○	○
HACR Circuit Breakers	25 to 80 Amp size available	x	x	x	x
Disconnect Switch	T1DISC080-1 (80 Amp) 80M00	x	x	x	x
GFI Service Outlets	LTAGFIK10/15 74M70	⊗	⊗	⊗	⊗
ECONOMIZER					
Economizer					
Economizer - Order LAOAH Hood Separately	TAREMD10/15 94M02	⊗	⊗	⊗	⊗
Economizer Controls					
Differential Enthalpy (dual)	C1SNSR07AE 86M33	x	x	x	x
Sensible (order two kits for Differential)	TASEK10/15 76M37	⊗	⊗	⊗	⊗
Single Outdoor Enthalpy	C1SNSR06AE 86M32	x	x	x	x
Barometric Relief					
Down-Flow Barometric Relief Dampers - Order Hood Separately	LAGED10/15 53K03	⊗	⊗	⊗	⊗
Hood for Down-Flow LAGED	LAGEH09/15 88K79	x	x	x	x
Horizontal Barometric Relief Dampers - Hood Furnished	LAGEDH03/15 53K04	x	x	x	x
OUTDOOR AIR					
Outdoor Air Dampers					
Damper Section - Order Hood Separately	Motorized - TAOADM10/15 73M74	⊗	⊗	⊗	⊗
	Manual - LAOAD10/15 66K69	⊗	⊗	⊗	⊗
Outdoor Air Hoods for Economizers and Outdoor Air Dampers					
Outdoor Air Hood (No. of Filters) - 16 x 25 x 1 in.	LAOAH10/15 (2) 53K05	⊗	⊗	⊗	⊗
POWER EXHAUST FANS					
Standard Static	208/230V - LAPEF10/15 73M32	⊗	⊗	⊗	⊗
	460V - LAPEF10/15 73M33	⊗	⊗	⊗	⊗
	575V - LAPEF10/15 73M35	⊗	⊗	⊗	⊗
INDOOR AIR QUALITY					
Indoor Air Quality (CO₂) Sensors					
CO ₂ Sensor Duct Mounting Kit	C0MISC19AE1- 85L43	x	x	x	x
Sensor - off- white case CO ₂ display	C0SNSR50AS1L 77N39	x	x	x	x
Sensor - off-white case no display	C0SNSR52AS1L 87N53	x	x	x	x
Sensor - black case CO ₂ display	C0SNSR51AS1L 87N52	x	x	x	x
Sensor - black case, no display	C0SNSR53AS1L 87N54	x	x	x	x
Aspiration Box for duct mounting	C0MISC16AE1- 90N43	x	x	x	x
Handheld CO ₂ Monitor	LTAIAQSHM03/36 70N93	x	x	x	x

NOTE - The catalog and part numbers that appear here are for ordering field installed accessories only.

⊗ - Field Installed or Configure to Order (factory installed)

○ - Configure to Order (Factory Installed)

X - Field Installed.

OPTIONS / ACCESSORIES

Item	Catalog No.	090	102	120	150
CEILING DIFFUSERS					
Step-Down Order one	RTD11-95	29G04	x		
	RTD11-135	29G05		x	x
	RTD11-185	29G06			x
	(Canada Only) RTD11-150/180S	13K63			x
Flush Order one	FD11-95	29G08	x		
	FD11-135	29G09		x	x
	FD11-185	29G10			x
	(Canada Only) FD11-150/180S	13K58			x
Transitions - (Supply and Return) Order one	LASRT10/12	49K55	x	x	x
	LASRT15	49K56			x
ROOF CURBS - CLIPLOCK 1000					
Down-Flow					
8 in. height	C1CURB40B	26W31	x	x	x
14 in. height	LARMF10/15S-14	65K34	x	x	x
18 in. height	LARMF10/15S-18	65K35	x	x	x
24 in. height	LARMF10/15S-24	65K36	x	x	x
ROOF CURBS - STANDARD					
Down-Flow					
14 in. height	LARMF10/15-14	53K50	x	x	x
24 in. height	LARMF10/15-24	49K54	x	x	x

NOTE - The catalog and part numbers that appear here are for ordering field installed accessories only.

⊗ - Field Installed or Configure to Order (factory installed)

X - Field Installed.

SPECIFICATIONS

7.5 AND 8.5 TON

General Data	Nominal Tonnage Model No. Efficiency Type	7.5 Ton		8.5 Ton	
		TGA090S2B	TGA090H2B	TGA102S2B	TGA102H2B
		Standard	High	Standard	High
Cooling Performance	Gross Cooling Capacity - Btuh	93,000	93,000	104,000	106,000
	¹ Net Cooling Capacity - Btuh	90,000	90,000	100,000	102,000
	ARI Rated Airflow - cfm	3000	3000	3400	3400
	Total Unit Power	8.9	8.0	9.9	9.2
	¹ EER (Btuh/Watt)	10.1	11.0	10.1	11.0
	² Integrated Part Load Value (Btuh/Watt)	10.5	11.4	10.5	11.4
	Refrigerant Charge Furnished (R-22)	Circuit 1 Circuit 2	7 lbs. 0 oz. 6 lbs. 8 oz.	8 lbs. 8 oz. 8 lbs. 8 oz.	7 lbs. 8 oz. 7 lbs. 0 oz.
³ Sound Rating Number (dB)		88	88	88	88
Gas Heating Options Available - See Page 11		Standard (S), Medium (M) or High (H)			
Compressor - Number & Type		(2) Scroll	(2) Scroll	(2) Scroll	(2) Scroll
Condenser Coil	Net face area - sq. ft.	29.3 total	29.3 total	29.3 (2.72) total	29.3 total
	Tube diameter - in.	3/8	3/8	3/8	3/8
	Number of rows	1	2	1	2
	Fins per inch	20	20	20	20
Condenser Fans	Motor horsepower	(2) 1/3	(2) 1/3	(2) 1/3	(2) 1/3
	Motor rpm	1075	1075	1075	1075
	Total Motor watts	700	700	700	700
	Diameter - in. - no. of blades	(2) 24 - 3	(2) 24 - 3	(2) 24 - 3	(2) 24 - 3
	Total air volume - cfm	8000	8000	8000	8000
Evaporator Coil	Net face area - sq. ft.	10.5 total	10.5 total	10.5 total	10.5 total
	Tube diameter - in.	3/8	3/8	3/8	3/8
	Number of rows	3	3	3	3
	Fins per inch	14	14	14	14
	Drain Connection - no. & size	(1) 1 in. NPT cplg	(1) 1 in. NPT cplg	(1) 1 in. NPT cplg	(1) 1 in. NPT cplg
	Expansion device type	Balanced Port Thermostatic Expansion Valve, removeable power head			
Standard Indoor Blower and Drive	⁴ Belt Drive - Nominal motor output	2 hp	2 hp	2 hp	2 hp
	Maximum usable output (US Only)	2.3 hp	2.3 hp	2.3 hp	2.3 hp
	Drive kit	kit #1 680 - 925 rpm	kit #1 680 - 925 rpm	kit #1 680 - 925 rpm	kit #1 680 - 925 rpm
	Wheel nom. diameter x width - in. (mm)	(1) 15 x 15	(1) 15 x 15	(1) 15 x 15	(1) 15 x 15
Filters	Type of filter	Disposable, pleated MERV 7 (standard) or MERV 11 (optional)			
	Number and size - in. (mm)	(4) 18 x 24 x 2	(4) 18 x 24 x 2	(4) 18 x 24 x 2	(4) 18 x 24 x 2
Electrical characteristics		208/230V, 460V or 575V - 60 hertz - 3 phase			

NOTE - Net capacity includes evaporator blower motor heat deduction. Gross capacity does not include evaporator blower motor heat deduction.

¹ Certified in accordance with the ULE certification program, which is based on ARI Standard 340/360, 95°F outdoor air temperature and 80°F db/67°F wb entering evaporator air; minimum external duct static pressure.

² Integrated Part Load Value rated at 80°F outdoor air temperature, 80°F db/67°F wb indoor air temperature.

³ Sound Rating Number rated in accordance with test conditions included in ARI Standard 270.

⁴ Maximum usable output of motors furnished by Lennox are shown. In Canada, nominal motor output is also maximum usable motor output. If motors of comparable output are used, be sure to keep within the service factor limitations outlined on the motor nameplate.

SPECIFICATIONS
10 AND 12.5 TON

General Data		Nominal Tonnage	10 Ton	10 Ton	12.5 Ton
		Model No.	TGA120S2B	TGA120H2B	TGA150S2B
		Efficiency Type	Standard	High	Standard
Cooling Performance	Gross Cooling Capacity - Btuh		126,000	126,000	145,000
	¹ Net Cooling Capacity - Btuh		120,000	120,000	138,000
	ARI Rated Airflow - cfm		3800	3800	4250
	Total Unit Power		11.8	10.9	14.5
	¹ EER (Btuh/Watt)		10.1	11.0	9.5
	² Integrated Part Load Value (Btuh/Watt)		10.5	11.4	9.2
	Refrigerant Charge Furnished (R-22)	Circuit 1	10 lbs. 0 oz.	10 lbs. 0 oz.	13 lbs. 0 oz.
		Circuit 2	10 lbs. 0 oz.	10 lbs. 0 oz.	12 lbs. 0 oz.
³ Sound Rating Number (dB)			88	88	88
Gas Heating Options Available - See Page 11			Medium (M) or High (H)		
Compressor - Number and Type			(2) Scroll	(2) Scroll	(2) Scroll
Condenser Coil	Net face area - sq. ft.		29.3 total	29.3 total	29.3 total
	Tube diameter - in.		3/8	3/8	3/8
	Number of rows		2	2	3
	Fins per inch		20	20	20
Condenser Fans	Motor horsepower		(2) 1/3	(2) 1/3	(2) 1/2
	Motor rpm		1075	1075	1075
	Total Motor watts		700	700	1150
	Diameter - in. - no. of blades		(2) 24 - 3	(2) 24 - 3	(2) 24 - 3
	Total air volume - cfm		8000	8000	9000
Evaporator Coil	Net face area - sq. ft.		10.5 total	10.5 total	10.5 total
	Tube diameter - in.		3/8	3/8	3/8
	Number of rows		4	4	4
	Fins per inch		14	14	14
	Drain Connection - no. & size		(1) 1 in. NPT coupling	(1) 1 in. NPT coupling	(1) 1 in. NPT coupling
Expansion device type			Balanced Port Thermostatic Expansion Valve, removeable power head		
Standard Indoor Blower and Drive	⁴ Belt Drive - Nominal motor output		3 hp	3 hp	5 hp
	Maximum usable output (US Only)		3.45 hp	3.45 hp	5.75 hp
	Motor - Drive kit		kit #3 - 895 - 1120 rpm	kit #3 - 895 - 1120 rpm	kit #6 - 1100 - 1395 rpm
	Wheel nominal diameter x width - in.		(1) 15 x 15	(1) 15 x 15	(1) 15 x 15
Filters	Type of filter		Disposable, pleated MERV 7 (standard) or MERV 11 (optional)		
	Number and size - in.		(4) 18 x 24 x 2	(4) 18 x 24 x 2	(4) 18 x 24 x 2
Electrical characteristics			208/230V, 460V or 575V - 60 hertz - 3 phase		

NOTE - Net capacity includes evaporator blower motor heat deduction. Gross capacity does not include evaporator blower motor heat deduction.

¹ Certified in accordance with the ULE certification program, which is based on ARI Standard 340/360, 95°F outdoor air temperature and 80°F db/67°F wb entering evaporator air; minimum external duct static pressure.

² Integrated Part Load Value rated at 80°F outdoor air temperature, 80°F db/67°F wb indoor air temperature.

³ Sound Rating Number rated in accordance with test conditions included in ARI Standard 270.

⁴ Maximum usable output of motors furnished by Lennox are shown. In Canada, nominal motor output is also maximum usable motor output. If motors of comparable output are used, be sure to keep within the service factor limitations outlined on the motor nameplate.

SPECIFICATIONS - GAS HEAT
7.5 - 12.5 TON

Usage Data		Used on Model No.	TGA090 TGA102	TGA090 TGA102 TGA120 TGA150	TGA090 TGA102 TGA120 TGA150
Gas Heating Performance	Heat Input Type		Standard (S)	Medium (M)	High (H)
	Input - Btuh	First Stage	84,500	117,000	156,000
		Second Stage	130,000	180,000	240,000
	Output - Btuh	Second Stage	104,000	144,000	192,000
	Temperature Rise Range - °F		15 - 45	30 - 60	40 - 70
	Thermal Efficiency			80%	
	Gas Supply Connections			3/4 in. npt	
	Gas Supply Pressure		7 in. w.c. Natural Gas / 11 in. w.c. LPG/Propane		

HIGH ALTITUDE DERATE

NOTE - Units may be installed at altitudes up to 2000 ft. above sea level without any modifications.
 At altitudes above 2000 ft. units must be derated to match information in the table shown.
 At altitudes above 4500 ft. unit must be derated 2% for each 1000 ft. above sea level.

NOTE - This is the only permissible derate for these units.

Heat Input Type	Altitude Feet	Gas Manifold Pressure in. w.g.		Input Rate (Btuh)
		Natural Gas	LPG/Propane	
Standard (2 stage)	2001 - 4500	3.4/1.6	9.6/5.5	84,500/ 124,000
Medium (2 stage)	2001 - 4500	3.4/1.6	9.6/5.5	117,000/ 172,000/
High (2 stage)	2001 - 4500	3.4/1.6	9.6/5.5	156,000/ 230,000/

COOLING RATINGS

NOTE - For Temperatures and Capacities not shown in tables, see bulletin - Cooling Unit Rating Table Correction Factor Data in Miscellaneous Engineering Data section.

12.5 TON STANDARD EFFICIENCY - COOLING CAPACITY - ONE COMPRESSOR OPERATING

TGA150S

Entering Wet Bulb Temperature	Total Air Volume		Outdoor Air Temperature Entering Outdoor Coil																							
			65°F (18°C)						75°F (24°C)						85°F (29°C)						95°F (35°C)					
			Total Cooling Capacity		Comp Motor kW Input	Sensible To Total Ratio (S/T) Dry Bulb			Total Cooling Capacity		Comp Motor kW Input	Sensible To Total Ratio (S/T) Dry Bulb			Total Cooling Capacity		Comp Motor kW Input	Sensible To Total Ratio (S/T) Dry Bulb			Total Cooling Capacity		Comp Motor kW Input	Sensible To Total Ratio (S/T) Dry Bulb		
			kBtuh	kW		75°F 24°C	80°F 27°C	85°F 29°C	kBtuh	kW		75°F 24°C	80°F 27°C	85°F 29°C	kBtuh	kW		75°F 24°C	80°F 27°C	85°F 29°C	kBtuh	kW		75°F 24°C	80°F 27°C	85°F 29°C
63°F (17°C)	3800	1795	71.7	21.0	3.91	.60	.76	.92	69.5	20.4	4.40	.61	.77	.94	67.3	19.7	4.93	.61	.79	.95	65.0	19.0	5.51	.63	.81	.97
	4400	2075	73.5	21.5	3.93	.63	.81	.98	71.2	20.9	4.44	.64	.83	.99	68.9	20.2	4.97	.66	.85	1.00	66.6	19.5	5.55	.67	.87	1.00
	5000	2360	75.1	22.0	3.96	.67	.87	1.00	72.8	21.3	4.46	.68	.89	1.00	70.4	20.6	4.99	.70	.91	1.00	68.0	19.9	5.58	.71	.93	1.00
67°F (19°C)	3800	1795	76.1	22.3	3.97	.47	.58	.71	73.7	21.6	4.47	.48	.58	.73	71.3	20.9	5.01	.48	.59	.74	68.8	20.2	5.59	.49	.60	.76
	4400	2075	77.8	22.8	3.99	.49	.60	.77	75.3	22.1	4.50	.49	.61	.79	72.8	21.3	5.04	.50	.63	.81	70.2	20.6	5.63	.50	.64	.83
	5000	2360	79.1	23.2	4.01	.50	.64	.82	76.6	22.4	4.52	.51	.65	.84	74.0	21.7	5.06	.51	.67	.87	71.3	20.9	5.66	.52	.69	.89
71°F (22°C)	3800	1795	81.0	23.7	4.04	.36	.46	.56	78.5	23.0	4.56	.36	.46	.56	75.9	22.2	5.10	.36	.47	.57	73.2	21.5	5.69	.36	.47	.58
	4400	2075	82.7	24.2	4.06	.36	.47	.58	80.0	23.4	4.58	.37	.48	.59	77.3	22.7	5.13	.37	.48	.60	74.5	21.8	5.73	.37	.49	.61
	5000	2360	84.0	24.6	4.08	.37	.49	.61	81.2	23.8	4.60	.37	.50	.63	78.5	23.0	5.15	.37	.50	.64	75.6	22.2	5.76	.38	.51	.66

12.5 TON STANDARD EFFICIENCY - COOLING CAPACITY - ALL COMPRESSORS OPERATING

TGA150S

Entering Wet Bulb Temperature	Total Air Volume		Outdoor Air Temperature Entering Outdoor Coil																							
			85°F (29°C)						95°F (35°C)						105°F (41°C)						115°F (46°C)					
			Total Cooling Capacity		Comp Motor kW Input	Sensible To Total Ratio (S/T) Dry Bulb			Total Cooling Capacity		Comp Motor kW Input	Sensible To Total Ratio (S/T) Dry Bulb			Total Cooling Capacity		Comp Motor kW Input	Sensible To Total Ratio (S/T) Dry Bulb			Total Cooling Capacity		Comp Motor kW Input	Sensible To Total Ratio (S/T) Dry Bulb		
			kBtuh	kW		75°F 24°C	80°F 27°C	85°F 29°C	kBtuh	kW		75°F 24°C	80°F 27°C	85°F 29°C	kBtuh	kW		75°F 24°C	80°F 27°C	85°F 29°C	kBtuh	kW		75°F 24°C	80°F 27°C	85°F 29°C
63°F (17°C)	3800	1795	139.4	40.9	9.95	.66	.81	.95	134.8	39.5	11.12	.67	.83	.97	129.7	38.0	12.43	.68	.85	.99	124.3	36.4	13.92	.70	.87	1.00
	4400	2075	142.8	41.9	10.02	.70	.87	.99	138.1	40.5	11.20	.71	.88	1.00	132.9	38.9	12.51	.72	.90	1.00	127.5	37.4	13.99	.74	.93	1.00
	5000	2360	145.9	42.8	10.08	.73	.91	1.00	141.0	41.3	11.26	.75	.93	1.00	135.9	39.8	12.58	.77	.95	1.00	130.2	38.2	14.07	.79	.97	1.00
67°F (19°C)	3800	1795	147.8	43.3	10.11	.52	.64	.77	142.7	41.8	11.29	.53	.65	.79	137.3	40.2	12.62	.53	.66	.81	131.5	38.5	14.12	.54	.67	.83
	4400	2075	150.9	44.2	10.17	.54	.67	.83	145.7	42.7	11.36	.55	.68	.85	140.0	41.0	12.69	.55	.70	.87	134.0	39.3	14.20	.56	.72	.89
	5000	2360	153.4	45.0	10.22	.56	.71	.88	148.0	43.4	11.42	.56	.72	.90	142.3	41.7	12.75	.57	.74	.92	136.2	39.9	14.24	.58	.76	.94
71°F (22°C)	3800	1795	157.3	46.1	10.29	.39	.51	.62	151.9	44.5	11.49	.40	.51	.63	146.1	42.8	12.84	.40	.52	.64	139.9	41.0	14.35	.40	.53	.65
	4400	2075	160.3	47.0	10.36	.40	.53	.65	154.6	45.3	11.56	.40	.53	.66	148.7	43.6	12.90	.40	.54	.67	142.3	41.7	14.42	.41	.55	.69
	5000	2360	162.7	47.7	10.40	.41	.55	.68	156.9	46.0	11.62	.41	.55	.70	150.7	44.2	12.96	.41	.56	.72	144.2	42.3	14.47	.42	.57	.74

OUTDOOR SOUND DATA

Unit Model No.	Octave Band Sound Power Levels dBA, re 10 ⁻¹² Watts							1 st Sound Rating Number (dB)
	Center Frequency - HZ							
	125	250	500	1000	2000	4000	8000	
090, 102, and 120S	76	79	84	83	79	73	66	88
120H and 150	77	80	85	84	79	74	66	88

NOTE - The octave sound power data shown does not include tonal correction.

¹ Tested according to ARI Standard 270-95 test conditions.

BLOWER DATA

BELT DRIVE BLOWER - BASE UNIT

BLOWER TABLE INCLUDES RESISTANCE FOR BASE UNIT ONLY (NO HEAT SECTION) WITH DRY INDOOR COIL AND AIR FILTERS IN PLACE. FOR ALL UNITS ADD:

- 1 - Wet indoor coil air resistance of selected unit.
- 2 - Any factory installed options air resistance (heat section, economizer, etc.)
- 3 - Any field installed accessories air resistance (duct resistance, diffuser, etc.)

Then determine from blower table blower motor output and drive required.

See below for blower motors and drives. See page 17 for wet coil and option/accessory air resistance data.

BOLD INDICATES FIELD FURNISHED DRIVE.

Air Volume cfm (L/s)	Total Static Pressure - in. w.g. (Pa)													
	.20 (50) RPM BHP (kW)	.40 (100) RPM BHP (kW)	.60 (150) RPM BHP (kW)	.80 (200) RPM BHP (kW)	1.00 (250) RPM BHP (kW)	1.20 (300) RPM BHP (kW)	1.40 (350) RPM BHP (kW)	1.60 (400) RPM BHP (kW)	1.80 (450) RPM BHP (kW)	2.00 (495) RPM BHP (kW)	2.20 (545) RPM BHP (kW)	2.40 (595) RPM BHP (kW)	2.60 (645) RPM BHP (kW)	
2250 (1060)	455 0.30 (0.22)	555 0.45 (0.34)	640 0.60 (0.45)	720 0.80 (0.60)	790 1.00 (0.75)	855 1.20 (0.90)	915 1.40 (1.04)	975 1.60 (1.19)	1030 1.85 (1.38)	1080 2.05 (1.53)	1130 2.30 (1.72)	1175 2.55 (1.90)	1220 2.80 (2.09)	
2500 (1180)	475 0.40 (0.30)	575 0.55 (0.41)	660 0.70 (0.52)	735 0.90 (0.67)	805 1.10 (0.82)	870 1.30 (0.97)	930 1.55 (1.16)	985 1.75 (1.31)	1040 2.00 (1.49)	1090 2.25 (1.68)	1140 2.50 (1.87)	1185 2.75 (2.05)	1230 3.00 (2.24)	
2750 (1300)	495 0.45 (0.34)	595 0.65 (0.48)	675 0.85 (0.63)	750 1.05 (0.78)	820 1.25 (0.93)	885 1.45 (1.08)	940 1.70 (1.27)	995 1.90 (1.42)	1050 2.20 (1.64)	1100 2.45 (1.83)	1145 2.65 (1.98)	1195 2.95 (2.20)	1240 3.25 (2.42)	
3000 (1415)	525 0.55 (0.41)	615 0.75 (0.56)	695 0.95 (0.71)	770 1.20 (0.90)	835 1.40 (1.04)	895 1.60 (1.19)	955 1.85 (1.38)	1010 2.10 (1.57)	1060 2.35 (1.75)	1110 2.65 (1.98)	1160 2.90 (2.16)	1205 3.20 (2.39)	1250 3.45 (2.57)	
3250 (1535)	550 0.65 (0.48)	640 0.90 (0.67)	715 1.10 (0.82)	790 1.35 (1.01)	855 1.60 (1.19)	915 1.80 (1.34)	970 2.05 (1.53)	1025 2.35 (1.75)	1075 2.60 (1.94)	1125 2.85 (2.13)	1170 3.15 (2.35)	1215 3.40 (2.54)	1260 3.70 (2.76)	
3500 (1650)	580 0.80 (0.60)	665 1.05 (0.78)	740 1.25 (0.93)	810 1.50 (1.12)	870 1.75 (1.31)	930 2.00 (1.49)	985 2.25 (1.68)	1040 2.55 (1.90)	1090 2.85 (2.13)	1135 3.10 (2.31)	1185 3.40 (2.54)	1230 3.70 (2.76)	1270 4.00 (2.98)	
3750 (1770)	605 0.95 (0.71)	690 1.20 (0.90)	760 1.45 (1.08)	830 1.70 (1.27)	890 1.95 (1.45)	950 2.25 (1.68)	1005 2.50 (1.87)	1055 2.80 (2.09)	1105 3.10 (2.31)	1150 3.35 (2.50)	1195 3.65 (2.72)	1240 3.95 (2.95)	1285 4.30 (3.21)	
4000 (1890)	635 1.10 (0.82)	715 1.40 (1.04)	785 1.65 (1.23)	850 1.90 (1.42)	910 2.20 (1.64)	965 2.45 (1.83)	1020 2.75 (2.05)	1070 3.05 (2.28)	1120 3.35 (2.50)	1165 3.65 (2.72)	1210 3.95 (2.95)	1255 4.30 (3.21)	1295 4.60 (3.43)	
4250 (2005)	665 1.30 (0.97)	740 1.60 (1.19)	810 1.85 (1.38)	870 2.15 (1.60)	930 2.45 (1.83)	985 2.75 (2.05)	1040 3.05 (2.28)	1090 3.35 (2.50)	1135 3.65 (2.72)	1185 4.00 (2.98)	1225 4.30 (3.21)	1270 4.65 (3.47)	1310 4.95 (3.69)	
4500 (2125)	695 1.50 (1.12)	770 1.80 (1.34)	835 2.10 (1.57)	895 2.40 (1.79)	955 2.70 (2.01)	1005 3.00 (2.24)	1060 3.35 (2.50)	1105 3.65 (2.72)	1155 4.00 (2.98)	1200 4.30 (3.21)	1245 4.65 (3.47)	1285 5.00 (3.73)	1325 5.30 (3.95)	
4750 (2240)	725 1.75 (1.31)	795 2.05 (1.53)	860 2.40 (1.79)	920 2.70 (2.01)	975 3.00 (2.24)	1030 3.35 (2.50)	1080 3.65 (2.72)	1125 3.95 (2.95)	1175 4.35 (3.25)	1215 4.65 (3.47)	1260 5.00 (3.73)	1300 5.35 (3.99)	1340 5.70 (4.25)	
5000 (2360)	760 2.05 (1.53)	825 2.35 (1.75)	885 2.65 (1.98)	945 3.00 (2.24)	1000 3.35 (2.50)	1050 3.65 (2.72)	1100 4.00 (2.98)	1145 4.35 (3.25)	1190 4.70 (3.51)	1235 5.05 (3.77)	1280 5.45 (4.07)	---	---	
5250 (2475)	790 2.30 (1.72)	855 2.65 (1.98)	910 2.95 (2.20)	970 3.35 (2.50)	1020 3.65 (2.72)	1070 4.00 (2.98)	1120 4.35 (3.25)	1165 4.70 (3.51)	1210 5.10 (3.80)	1255 5.45 (4.07)	---	---	---	
5500 (2595)	820 2.60 (1.94)	880 2.95 (2.20)	940 3.30 (2.46)	995 3.70 (2.76)	1045 4.05 (3.02)	1095 4.40 (3.28)	1145 4.80 (3.58)	1190 5.15 (3.84)	1230 5.50 (4.10)	---	---	---	---	
5750 (2715)	850 2.95 (2.20)	910 3.30 (2.46)	965 3.70 (2.76)	1020 4.05 (3.02)	1070 4.45 (3.32)	1120 4.80 (3.58)	1165 5.20 (3.88)	1210 5.60 (4.18)	---	---	---	---	---	
6000 (2830)	885 3.35 (2.50)	940 3.70 (2.76)	995 4.10 (3.06)	1045 4.45 (3.32)	1095 4.85 (3.62)	1145 5.25 (3.92)	1190 5.65 (4.21)	---	---	---	---	---	---	

FACTORY INSTALLED DRIVE KIT SPECIFICATIONS

Motor Horsepower		RPM Range				
Nominal	Maximum	Drive 1	Drive 3	Drive 4	Drive 5	Drive 6
2	2.3	680 - 925	895 - 1120	---	---	---
3	3.45	680 - 925	895 - 1120	---	1110 - 1395	---
5	5.75	---	---	895 - 1120	---	1110 - 1395

NOTE - Using total air volume and system static pressure requirements determine from blower performance tables rpm and motor output required. Maximum usable output of motors furnished by Lennox are shown. In Canada, nominal motor output is also maximum usable motor output. If motors of comparable output are used, be sure to keep within the service factor limitations outlined on the motor nameplate.

BLOWER DATA

OPTIONS / ACCESSORY AIR RESISTANCE - in. w.g.

Air Volume cfm	Wet Indoor Coil		Gas Heat Exchanger			Economizer
	090, 102	120S, 120H, 150S	Standard Heat	Medium Heat	High Heat	
2250	0.06	0.10	0.05	0.07	0.09	0.035
2500	0.08	0.12	0.05	0.09	0.11	0.04
2750	0.09	0.14	0.06	0.10	0.13	0.045
3000	0.10	0.16	0.07	0.12	0.16	0.05
3250	0.11	0.19	0.08	0.15	0.19	0.06
3500	0.13	0.21	0.09	0.17	0.22	0.07
3750	0.14	0.23	0.10	0.20	0.26	0.075
4000	0.16	0.26	0.11	0.22	0.30	0.08
4250	0.17	0.28	0.12	0.25	0.34	0.09
4500	0.18	0.31	0.13	0.28	0.38	0.10
4750	0.20	0.33	0.14	0.31	0.42	0.11
5000	0.22	0.36	0.16	0.35	0.47	0.12
5250	0.24	0.39	0.18	0.38	0.52	0.13
5500	0.26	0.42	0.20	0.42	0.57	0.14
5750	0.28	0.45	0.22	0.46	0.62	0.15
6000	0.30	0.48	0.24	0.50	0.68	0.16

AIR RESISTANCE (in. w.g.) - CEILING DIFFUSERS

Unit Size	Air Volume cfm	RTD11 Step-Down Diffuser			FD11 Flush Diffuser
		2 Ends Open	1 Side, 2 Ends Open	All Ends & Sides Open	
090 Models	2400	0.21	0.18	0.15	0.14
	2600	0.24	0.21	0.18	0.17
	2800	0.27	0.24	0.21	0.20
	3000	0.32	0.29	0.25	0.25
	3200	0.41	0.37	0.32	0.31
	3400	0.50	0.45	0.39	0.37
	3600	0.61	0.54	0.48	0.44
102 & 120 Models	3800	0.73	0.63	0.57	0.51
	3600	0.36	0.28	0.23	0.15
	3800	0.40	0.32	0.26	0.18
	4000	0.44	0.36	0.29	0.21
	4200	0.49	0.40	0.33	0.24
	4400	0.54	0.44	0.37	0.27
	4600	0.60	0.49	0.42	0.31
150 Models	4800	0.65	0.53	0.46	0.35
	5000	0.69	0.58	0.50	0.39
	5200	0.75	0.62	0.54	0.43
	4200	0.22	0.19	0.16	0.10
	4400	0.28	0.24	0.20	0.12
	4600	0.34	0.29	0.24	0.15
	4800	0.40	0.34	0.29	0.19
150 Models	5000	0.46	0.39	0.34	0.23
	5200	0.52	0.44	0.39	0.27
	5400	0.58	0.49	0.43	0.31
	5600	0.64	0.54	0.47	0.35
	5800	0.70	0.59	0.51	0.39

BLOWER DATA

CEILING DIFFUSER AIR THROW DATA

Model No.	Air Volume cfm	¹ Effective Throw Range - ft.	
		RTD11 Step-Down	FD11 Flush
090	2600	24 - 29	19 - 24
	2800	25 - 30	20 - 28
	3000	27 - 33	21 - 29
	3200	28 - 35	22 - 29
	3400	30 - 37	22 - 30
102 120	3600	25 - 33	22 - 29
	3800	27 - 35	22 - 30
	4000	29 - 37	24 - 33
	4200	32 - 40	26 - 35
	4400	34 - 42	28 - 37
150	5600	39 - 49	28 - 37
	5800	42 - 51	29 - 38
	6000	44 - 54	40 - 50
	6200	45 - 55	42 - 51
	6400	46 - 55	43 - 52
	6600	47 - 56	45 - 56

POWER EXHAUST FANS PERFORMANCE

Return Air System Static Pressure - in. w.g.	Air Volume Exhausted - cfm
0	4200
0.05	3970
0.10	3750
0.15	3520
0.20	3300
0.25	3080
0.30	2860
0.35	2640

¹ Throw is the horizontal or vertical distance an air stream travels on leaving the outlet or diffuser before the maximum velocity is reduced to 50 ft. (15 m) per minute. Four sides open.

ELECTRICAL DATA

7.5 TON STANDARD / HIGH EFFICIENCY (R-22)

TGA090

Model No.	TGA090S						TGA090H							
	208/230V		460V		575V		208/230V		460V		575V			
Line voltage data - 60 Hz - 3 phase	208/230V		460V		575V		208/230V		460V		575V			
Compressors (2)	Rated load amps - each (total)		12.8 (25.6)		6.4 (12.8)		5.1 (10.2)		12.4 (24.9)		6.4 (12.8)		4.8 (9.6)	
	Locked rotor amps - each (total)		91 (182)		46 (92)		37 (74)		88 (176)		44 (88)		34 (68)	
Condenser Fan Motor	Number of motors		2		2		2		2		2		2	
	Full load amps - each (total)		2.4 (4.8)		1.3 (2.6)		1.0 (2.0)		2.4 (4.8)		1.3 (2.6)		1.0 (2.0)	
	Locked rotor amps - each (total)		4.7 (9.4)		2.4 (4.8)		1.9 (3.8)		4.7 (9.4)		2.4 (4.8)		1.9 (3.8)	
Evaporator Blower Motor	Horsepower		2 3		2 3		2 3		2 3		2 3		2 3	
	Full load amps		7.5 10.6		3.4 4.8		2.7 3.9		7.5 10.6		3.4 4.8		2.7 3.9	
	Locked rotor amps		46.9 66		20.4 26.8		16.2 23.4		46.9 66		20.4 26.8		16.2 23.4	
¹ Maximum Overcurrent Protection (amps)	Unit Only		50 50		25 25		20 20		50 50		25 25		20 20	
	With Exhaust Fan		50 50		25 25		20 20		50 50		25 25		20 20	
² Minimum Circuit Ampacity	Unit Only		42 45		21 22		17 18		41 44		21 22		16 17	
	With Exhaust Fan		44 47		22 24		18 19		43 46		22 24		17 18	
Optional Power Exhaust Fan	(Number) Horsepower		(1) 1/3		(1) 1/3		(1) 1/3		(1) 1/3		(1) 1/3		(1) 1/3	
	Full load amps		2.4		1.3		1.0		2.4		1.3		1.0	
	Locked rotor amps		4.7		2.4		1.9		4.7		2.4		1.9	
Service Outlet (2) 115 volt GFCI (amp rating)			15		15		15		15		15		15	

NOTE - Extremes of operating range are plus and minus 10 % of line voltage.

¹ HACR type breaker or fuse.

² Refer to National or Canadian Electrical Code manual to determine wire, fuse and disconnect size requirements.

ELECTRICAL DATA

8.5 TON STANDARD / HIGH EFFICIENCY (R-22)

TGA102

Model No.		TGA102S						TGA102H					
Line voltage data - 60 Hz - 3 phase		208/230V		460V		575V		208/230V		460V		575V	
Compressors (2)	Rated load amps - each (total)	14.7 (29.4)		7.1 (14.2)		5.8 (11.6)		14.7 (29.4)		7.1 (14.2)		5.1 (10.2)	
	Locked rotor amps - each (total)	91 (182)		50 (100)		37 (74)		91 (182)		46 (92)		37 (74)	
Condenser Fan Motors (2)	Full load amps - each (total)	2.4 (4.8)		1.3 (2.6)		1.0 (2.0)		2.4 (4.8)		1.3 (2.6)		1.0 (2.0)	
	Locked rotor amps - each (total)	4.7 (9.4)		2.4 (4.8)		1.9 (3.8)		4.7 (9.4)		2.4 (4.8)		1.9 (3.8)	
Evaporator Blower Motor	Horsepower	2	3	2	3	2	3	2	3	2	3	2	3
	Full load amps	7.5	10.6	3.4	4.8	2.7	3.9	7.5	10.6	3.4	4.8	2.7	3.9
	Locked rotor amps	46.9	66	20.4	26.8	16.2	23.4	46.9	66	20.4	26.8	16.2	23.4
¹ Maximum Overcurrent Protection (amps)	Unit Only	60	60	25	30	20	20	60	60	25	30	20	20
	With Exhaust Fan	60	60	30	30	20	25	60	60	30	30	20	20
² Minimum Circuit Ampacity	Unit Only	46	49	22	24	18	19	46	49	22	24	17	18
	With Exhaust Fan	48	51	24	25	19	20	48	51	24	25	18	19
Optional Power Exhaust Fan	(Number) Horsepower	(1) 1/3		(1) 1/3		(1) 1/3		(1) 1/3		(1) 1/3		(1) 1/3	
	Full load amps	2.4		1.3		1.0		2.4		1.3		1.0	
	Locked rotor amps	4.7		2.4		1.9		4.7		2.4		1.9	
Service Outlet (2) 115 volt GFCI (amp rating)		15		15		15		15		15		15	

10 TON STANDARD EFFICIENCY

TGA120

Model No.		TGA120S								
Line voltage data - 60 Hz - 3 phase		208/230V			460V			575V		
Compressors (2)	Rated load amps - each (total)	15.4 (30.8)			7.4 (14.8)			5.9 (11.8)		
	Locked rotor amps - each (total)	124 (248)			59.6 (119.2)			49.4 (98.8)		
Condenser Fan Motors (2)	Full load amps - each (total)	2.4 (4.8)			1.3 (2.6)			1.0 (2.0)		
	Locked rotor amps - each (total)	4.7 (9.4)			2.4 (4.8)			1.9 (3.8)		
Evaporator Blower Motor	Horsepower	2	3	5	2	3	5	2	3	5
	Full load amps	7.5	10.6	16.7	3.4	4.8	7.6	2.7	3.9	6.1
	Locked rotor amps	46.9	66	105	20.4	26.8	45.6	16.2	23.4	36.6
¹ Maximum Overcurrent Protection (amps)	Unit Only	60	60	70	30	30	30	20	25	25
	With Exhaust Fan	60	60	70	30	30	35	20	25	25
² Minimum Circuit Ampacity	Unit Only	47	51	57	23	25	27	18	20	22
	With Exhaust Fan	50	53	59	24	26	29	19	21	23
Optional Power Exhaust Fan	(Number) Horsepower	(1) 1/3			(1) 1/3			(1) 1/3		
	Full load amps	2.4			1.3			1.0		
	Locked rotor amps	4.7			2.4			1.9		
Service Outlet (2) 115 volt GFCI (amp rating)		15			15			15		

10 TON HIGH EFFICIENCY

TGA120

Model No.		TGA120H								
Line voltage data - 60 Hz - 3 phase		208/230V			460V			575V		
Compressors (2)	Rated load amps - each (total)	17.3 (34.6)			9.0 (18.0)			7.1 (14.2)		
	Locked rotor amps - each (total)	123 (246)			62 (124)			50 (100)		
Condenser Fan Motors (2)	Full load amps - each (total)	2.4 (4.8)			1.3 (2.6)			1.0 (2.0)		
	Locked rotor amps - each (total)	4.7 (9.4)			2.4 (4.8)			1.9 (3.8)		
Evaporator Blower Motor	Horsepower	2	3	5	2	3	5	2	3	5
	Full load amps	7.5	10.6	16.7	3.4	4.8	7.6	2.7	3.9	6.1
	Locked rotor amps	46.9	66	105	20.4	26.8	45.6	16.2	23.4	36.6
¹ Maximum Overcurrent Protection (amps)	Unit Only	60	70	70	35	35	35	25	25	30
	With Exhaust Fan	70	70	80	35	35	40	25	30	30
² Minimum Circuit Ampacity	Unit Only	52	55	61	27	28	31	21	22	25
	With Exhaust Fan	54	57	63	28	29	32	22	23	26
Optional Power Exhaust Fan	(Number) Horsepower	(1) 1/3			(1) 1/3			(1) 1/3		
	Full load amps	2.4			1.3			1.0		
	Locked rotor amps	4.7			2.4			1.9		
Service Outlet (2) 115 volt GFCI (amp rating)		15			15			15		

NOTE - Extremes of operating range are plus and minus 10 % of line voltage.

¹ HACR type breaker or fuse.

² Refer to National or Canadian Electrical Code manual to determine wire, fuse and disconnect size requirements.

ELECTRICAL DATA

12.5 TON STANDARD EFFICIENCY

TGA150

Model No.		TGA150S					
Line voltage data - 60 Hz - 3 phase		208/230V		460V		575V	
Compressors (2)	Rated load amps - each (total)	18.6 (37.2)		9 (18)		7.4 (14.8)	
	Locked rotor amps - each (total)	156 (312)		75 (150)		54 (108)	
Condenser Fan Motors (2)	Full load amps - each (total)	3.0 (6.0)		1.5 (3.0)		1.2 (2.4)	
	Locked rotor amps - each (total)	6.0 (12.0)		3.0 (6.0)		2.9 (5.8)	
Evaporator Blower Motor	Horsepower	3	5	3	5	3	5
	Full load amps	10.6	16.7	4.8	7.6	3.9	6.1
	Locked rotor amps	66	105	26.8	45.6	23.4	36.6
¹ Maximum Overcurrent Protection (amps)	Unit Only	70	80	35	35	30	30
	With Exhaust Fan	70	80	35	40	30	30
² Minimum Circuit Ampacity	Unit Only	59	65	29	31	23	26
	With Exhaust Fan	61	67	30	33	24	27
Optional Power Exhaust Fan	(Number) Horsepower	(1) 1/3		(1) 1/3		(1) 1/3	
	Full load amps	2.4		1.3		1.0	
	Locked rotor amps	4.7		2.4		1.9	
Service Outlet (2) 115 volt GFCI (amp rating)		15		15		15	

NOTE - Extremes of operating range are plus and minus 10 % of line voltage.

¹ HACR type breaker or fuse.

² Refer to National or Canadian Electrical Code manual to determine wire, fuse and disconnect size requirements.

UNIT CLEARANCES - INCHES (MM)

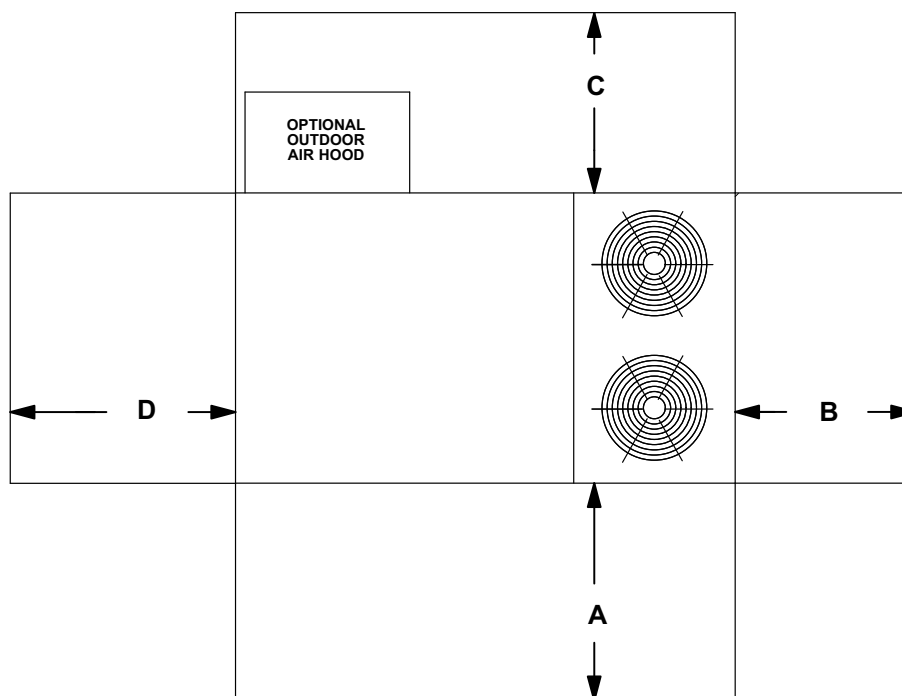

1 Unit Clearance	A		B		C		D		Top Clearance
	in.	mm	in.	mm	in.	mm	in.	mm	
Service Clearance	60	1524	36	914	36	914	36	914	Unobstructed
Clearance to Combustibles	36	914	1	25	1	25	1	25	
Minimum Operation Clearance	36	914	36	914	36	914	36	914	

NOTE - Entire perimeter of unit base requires support when elevated above the mounting surface.

¹ Service Clearance - Required for removal of serviceable parts.

Clearance to Combustibles - Required clearance to combustible material.

Minimum Operation Clearance - Required clearance for proper unit operation.

OPTIONAL CONVENTIONAL TEMPERATURE CONTROL SYSTEMS - FIELD INSTALLED

COMMERCIAL TOUCHSCREEN THERMOSTAT



Intuitive Touchscreen Interface - **Two Stage Heating / Two Stage Cooling Conventional or Heat Pump** - Seven Day Programmable - Four Time Periods/Day - Economizer Output - Title 24 Compliant - ENERGY STAR® Qualified - Backlit Display - Automatic Changeover

C0STAT02AE1L

Sensors For Touchscreen Thermostat

1 Remote non-adjustable wall mount 20k temperature sensor	C0SNZN01AE2-
1 Remote non-adjustable wall mount 10k averaging temperature sensor	C0SNZN73AE2-
1 Remote non-adjustable duct mount temperature sensor	C0SNDC00AE1-
Outdoor temperature sensor	C0SNSR03AE1-

Accessories For Touchscreen Thermostat

Locking cover (clear)	C0MISC15AE1-
-----------------------------	--------------

¹ Remote sensors for C0STAT02AE1L can be applied in the following combinations: (1) C0SNZN01AE1-, (2) C0SNZN73AE1-, (2) C0SNZN01AE1- and (1) C0SNZN73AE1-, (4) C0SNZN01AE1-, (3) C0SNZN01AE1- and (2) C0SNZN73AE1.

DIGITAL NON-PROGRAMMABLE THERMOSTATS



Intuitive Interface - Automatic Changeover - Simple Up and Down Temperature Control

Two-stage heating / cooling conventional systems	C0STAT10AE1L
---------------------------------------------------------------	--------------

Sensor For Digital Non-Programmable Thermostats Above

Remote wall mounted temperature sensor	C0SNZN00AE1-
----------------------------------------------	--------------

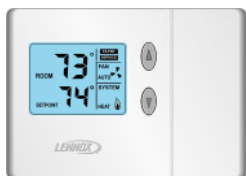

Intuitive Interface - Automatic Changeover - Backlit Display - Simple Up and Down Temperature Control

One-stage heating / cooling conventional systems	C0STAT12AE1L
---------------------------------------------------------------	--------------

Sensor For Digital Non-Programmable Thermostats Above

Outdoor temperature sensor	C0SNSR04AE1-
----------------------------------	--------------

Accessories For Digital Non-Programmable Thermostats Above

Optional wall mounting plate	C0MISC17AE1-
------------------------------------	--------------

WEIGHT DATA

Model Number	Net				Shipping			
	Base		Max.		Base		Max.	
	lbs.	kg	lbs.	kg	lbs.	kg	lbs.	kg
090/102	1300	590	1525	692	1385	628	1610	730
120	1355	615	1580	717	1440	653	1665	755
150	1390	630	1615	733	1475	669	1700	771

Base Unit - The unit with NO OPTIONS.

Max. Unit - The unit with ALL OPTIONS installed (Economizer, etc.).

OPTIONS / ACCESSORIES

			Shipping Weights	
			lbs.	kg
ECONOMIZER / OUTDOOR AIR				
Economizer				
Economizer		TAREMD10/15	131	59
Outdoor Air Hood				
Outdoor Air Hood		LAOAH10/15	30	14
OUTDOOR AIR				
Outdoor Air Dampers				
Outdoor Air Damper Motorized Kit		TAOADM10/15	117	53
		LAOAD10/15	11	5
Power Exhaust				
Standard Static		LAPEF10/15	82	37
ROOF CURBS - STANDARD				
Down-Flow				
14 in. height		LARMF10/15-14	126	57
24 in. height		LARMF10/15-24	174	79
ROOF CURBS - CLIPLOCK 1000				
Down-Flow				
14 in. height		LARMF10/15S-14	115	52
18 in. height		LARMF10/15S-28	156	71
24 in. height		LARMF10/15S-24	189	86
CEILING DIFFUSERS				
Step-Down		RTD11-95	88	40
		RTD11-135	205	93
		RTD11-185	392	178
Flush		FD11-95	75	34
		FD11-135	174	79
		FD11-185	289	131
Transitions		LASRT08/10	30	14
		LASRT10/12	32	15
		LASRT15	36	16
PACKAGING				
LTL Packaging (less than truck load)			105	48

DIMENSIONS - INCHES (MM)

Model Number	WEIGHTS				CORNER WEIGHTS								CENTER OF GRAVITY			
	Net		Shipping		AA		BB		CC		DD		EE		FF	
	lbs.	kg	lbs.	kg	lbs.	kg	lbs.	kg	lbs.	kg	lbs.	kg	inch	mm	inch	mm
090/102 Base Unit	1300	590	1385	628	314	142	289	131	329	149	368	167	47	1194	21-1/2	546
090/102 Max. Unit	1525	692	1610	730	381	173	339	154	374	170	431	195	46	1168	23-1/2	597
120 Base Unit	1355	615	1440	653	328	149	300	136	343	156	384	174	47	1194	21-1/2	546
120 Max. Unit	1580	717	1665	755	394	179	352	160	387	176	447	203	46	1168	23-1/2	597
150 Base Unit	1390	630	1475	669	336	152	312	152	353	160	389	176	47-1/2	1207	22	559
150 Max. Unit	1615	733	1700	771	403	183	364	165	398	181	450	204	46-1/2	1181	24	610

Base Unit - The unit with low fire heat exchanger NO OPTIONS.

Max. Unit - The unit with ALL OPTIONS Installed. (Economizer, High Input Heating and Controls)

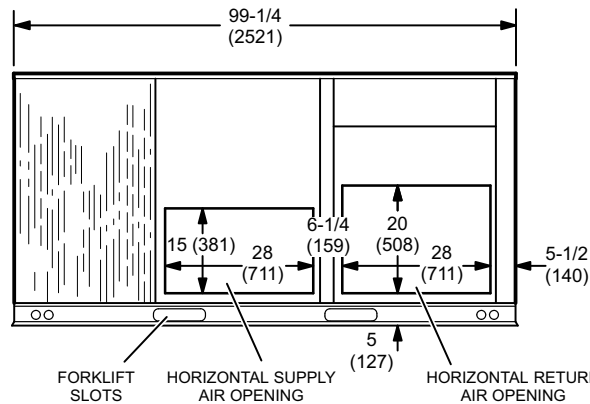
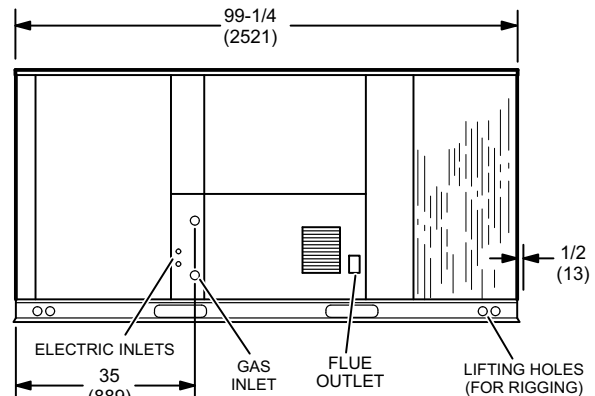
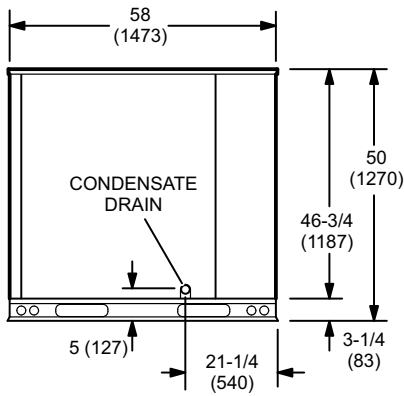
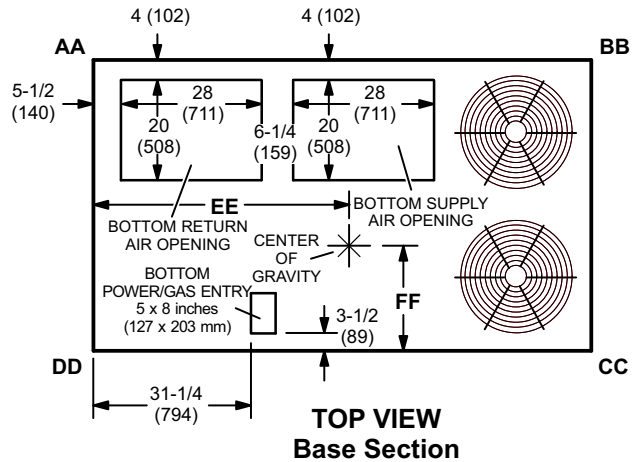

OPTIONAL OUTDOOR AIR HOOD DETAIL

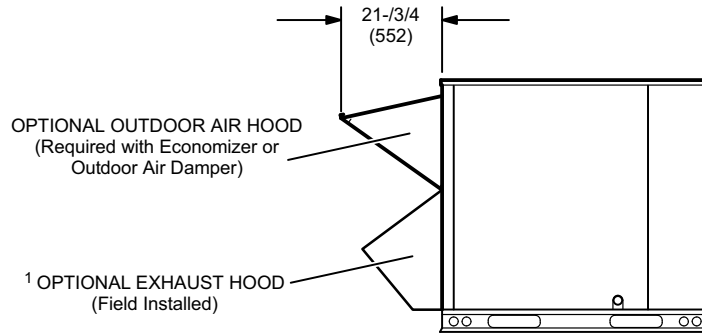

¹ NOTE — Field Installed in Return Air Duct for Horizontal Applications.

HORIZONTAL BAROMETRIC RELIEF DAMPERS
(Field installed in horizontal return air duct adjacent to unit)

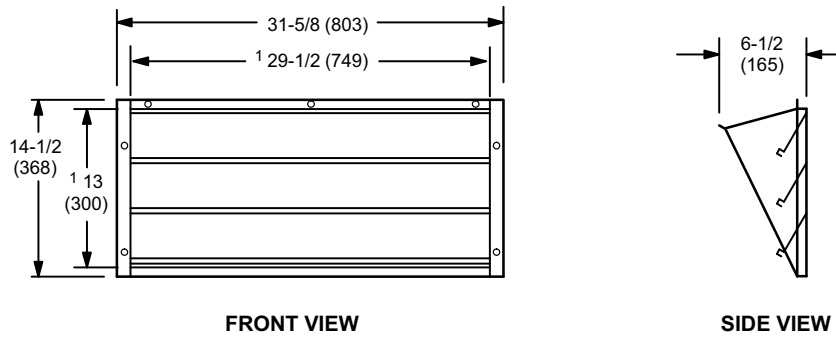

¹ NOTE - Opening size required in return air duct.

ACCESSORY DIMENSIONS - INCHES (MM)

STANDARD ROOF CURBS - DOUBLE DUCT OPENING

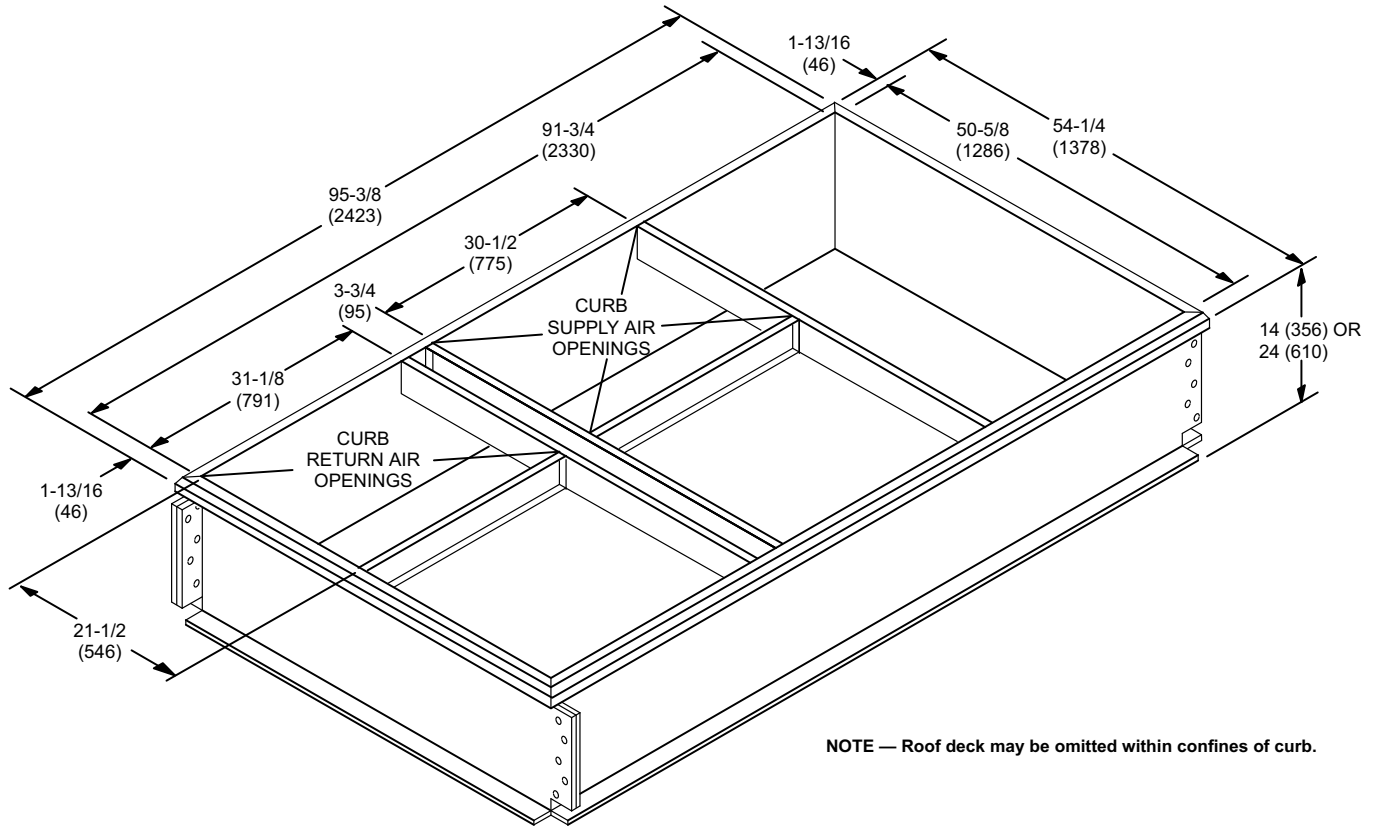

NOTE — Roof deck may be omitted within confines of curb.

TYPICAL FLASHING DETAIL FOR ROOF CURB

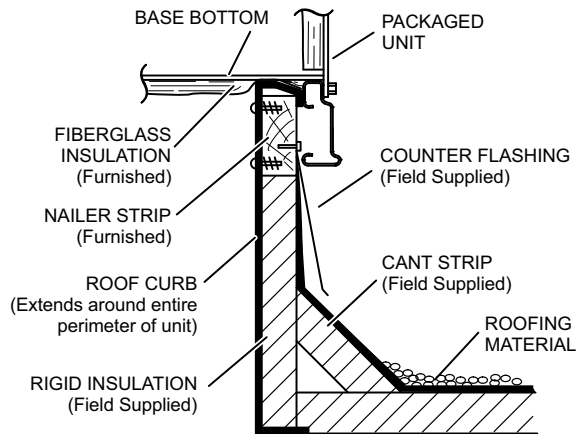

DETAIL ROOF CURB

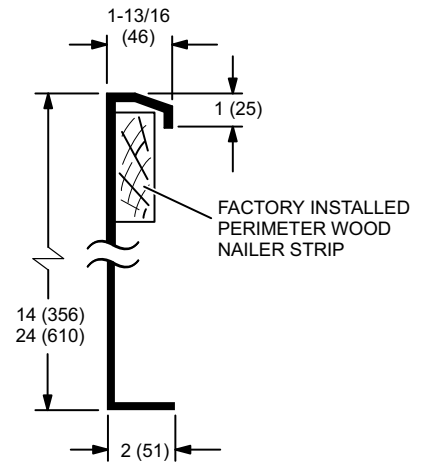

ACCESSORY DIMENSIONS - INCHES (MM)

CLIPLOCK 1000 ROOF CURBS - DOUBLE DUCT OPENING

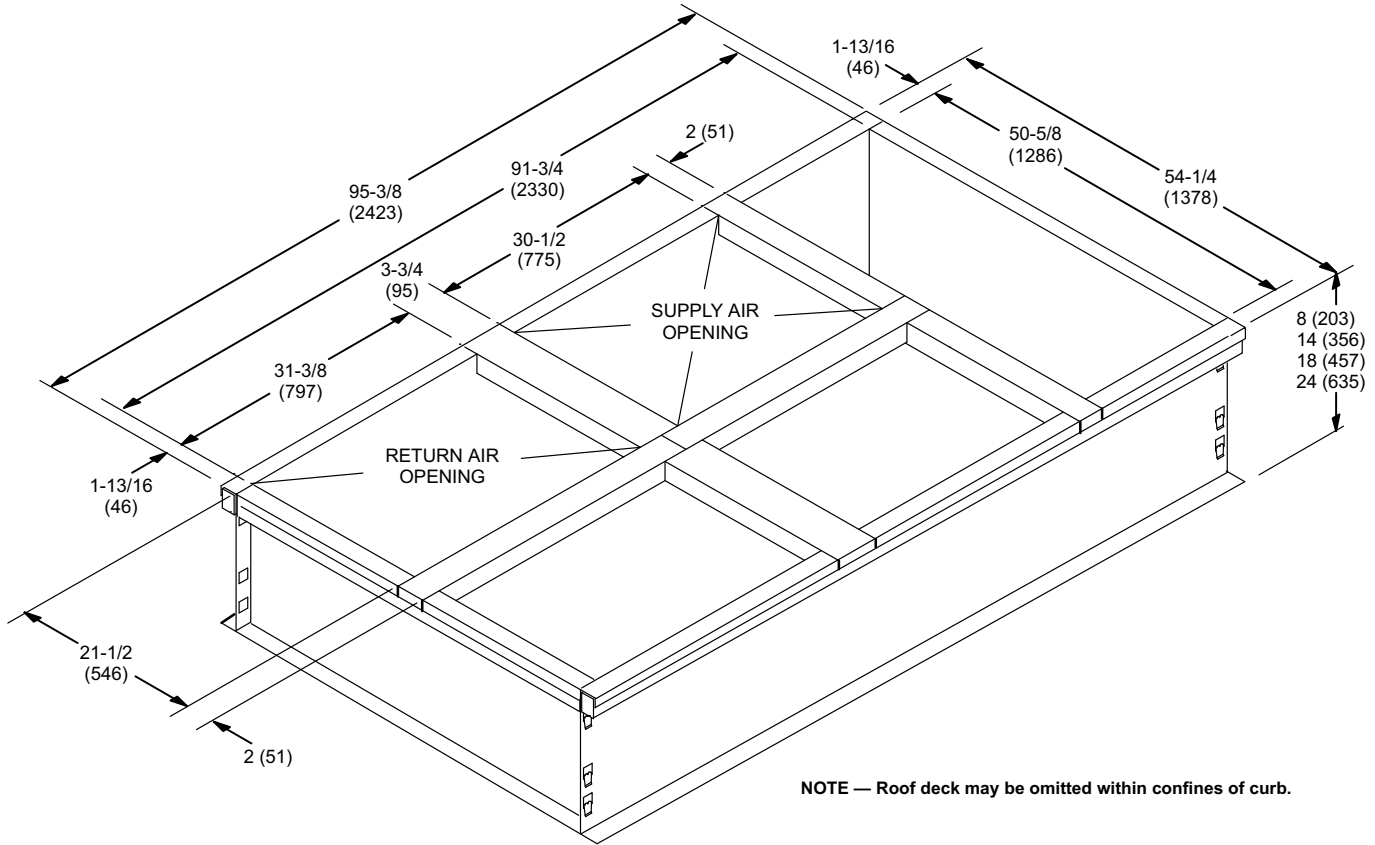

TYPICAL FLASHING DETAIL FOR ROOF CURB

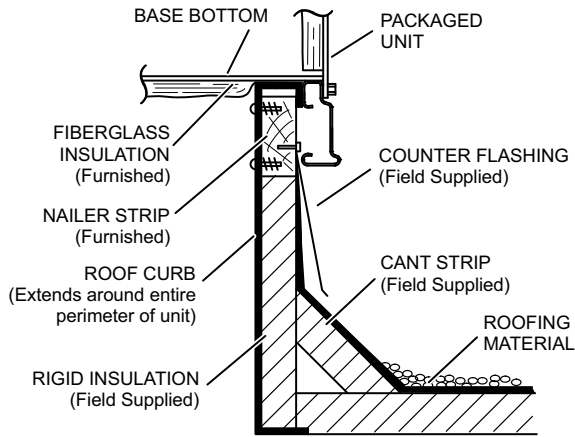

DETAIL ROOF CURB

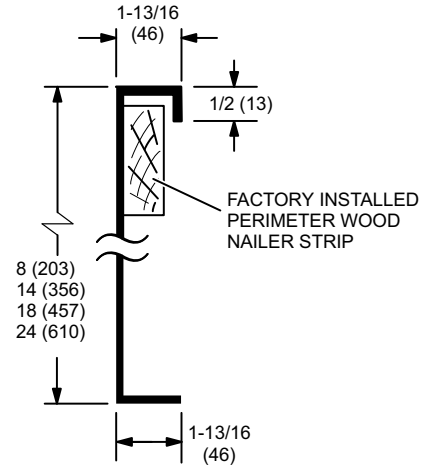

ACCESSORY DIMENSIONS - INCHES (MM)

ROOF CURBS WITH SUPPLY & RETURN AIR TRANSITIONS FOR CEILING DIFFUSERS

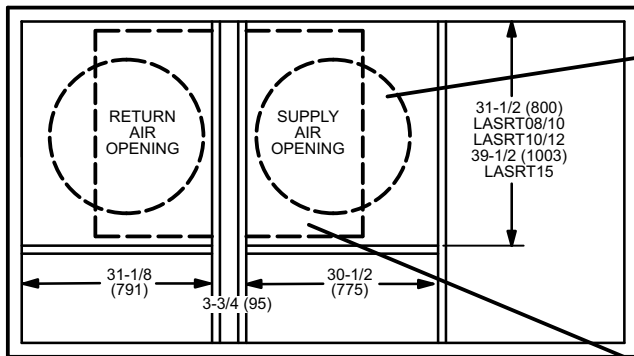

TOP VIEW

LASRT08/10 ROUND TRANSITIONS
(for 090 models with FD11-95, RTD11-95 Diffusers)

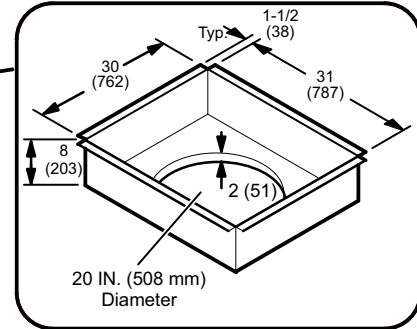

LASRT10/12 & LASRT15 RECTANGULAR TRANSITIONS
(for 102 thru 150 models with FD11-135-185, RTD11-135-185 Diffusers)

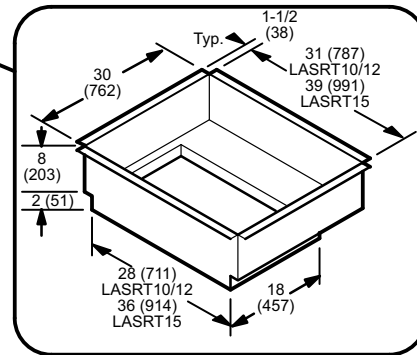

ACCESSORY DIMENSIONS - INCHES (MM)

COMBINATION CEILING SUPPLY AND RETURN DIFFUSERS

RTD11-95 STEP-DOWN CEILING DIFFUSER

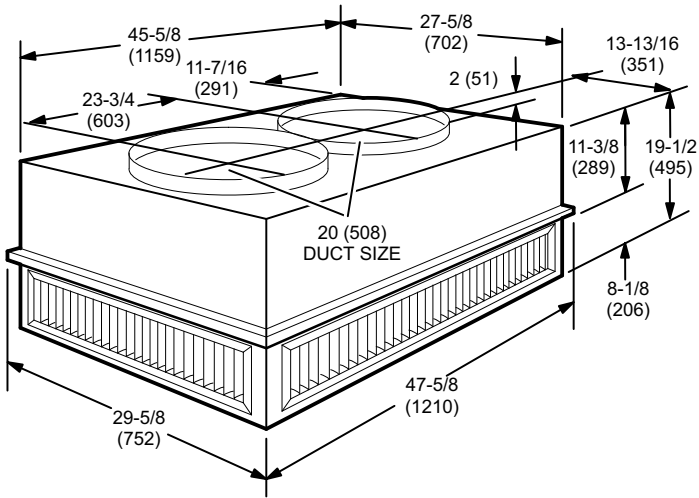

FD11-95 FLUSH CEILING DIFFUSER

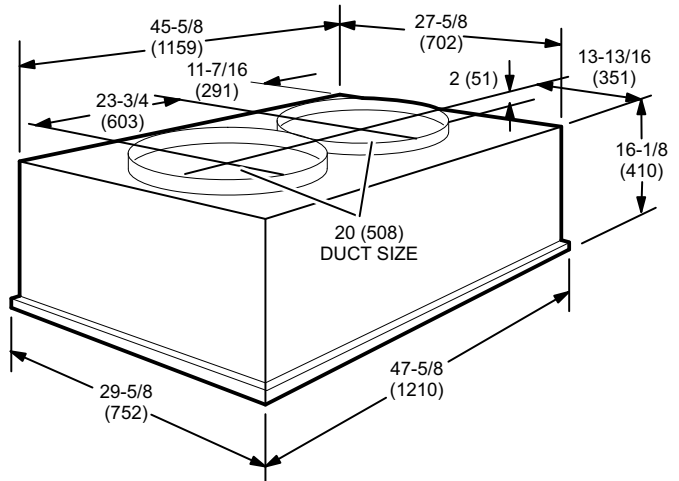

**RTD11-135 & RTD11-185
STEP-DOWN CEILING DIFFUSER**

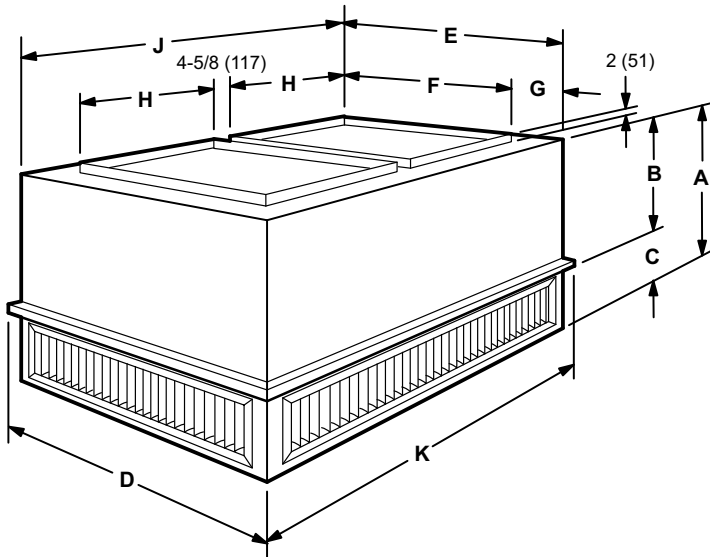

**FD11-135 & FD11-185
FLUSH CEILING DIFFUSER**

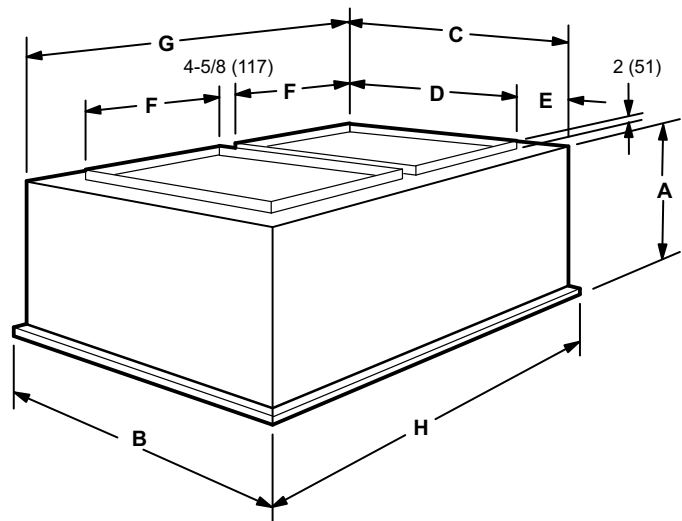

Model Number	A		B		C		D		E	
	inch	mm	inch	mm	inch	mm	inch	mm	inch	mm
RTD11-135	28	711	18-7/8	479	9-1/8	232	35-5/8	905	33-5/8	854
RTD11-185	34	864	23-7/8	606	10-1/8	257	47-5/8	1210	45-5/8	1159

Model Number	A		B		C		D	
	inch	mm	inch	mm	inch	mm	inch	mm
FD11-135	24-1/8	613	35-5/8	905	33-5/8	854	28	711
FD11-185	30-1/8	613	47-5/8	1210	45-5/8	1159	36	914

Model Number	F		G		H		J		K	
	inch	mm	inch	mm	inch	mm	inch	mm	inch	mm
RTD11-135	28	711	2-13/16	71	18	457	45-5/8	1159	47-5/8	1210
RTD11-185	36	914	4-13/16	122	18	457	45-5/8	1159	47-5/8	1210

Model Number	E		F		G		H	
	inch	mm	inch	mm	inch	mm	inch	mm
FD11-135	2-13/16	71	18	457	45-5/8	1159	47-5/8	1210
FD11-185	4-13/16	122	18	457	45-5/8	1159	47-5/8	1210

SECTION 15730**UNITARY AIR CONDITIONING EQUIPMENT****PART 1 GENERAL****PART 1.01 SUMMARY**

- A. Section Includes: Packaged rooftop units and commercial packaged, gas/electric, electric/electric and electric/heat pumps.

Specifier Note: Revise paragraph below to suit project requirements. Add section numbers and titles per CSI *MasterFormat* and specifier's practice.

- B. Related Sections:

Specifier Note: Article below may be omitted when specifying manufacturer's proprietary products and recommended installation. Retain Reference Article when specifying products and installation by an industry reference standard. If retained, list standard(s) referenced in this section. Indicate issuing authority name, acronym, standard designation and title. Establish policy for indicating edition date of standard referenced. Conditions of the Contract or Division 1 References Section may establish the edition date of standards. This article does not require compliance with standard, but is merely a listing of references used. Article below should list only those industry standards referenced in this section. Retain only those reference standards to be used within the text of this Section. Add and delete as required for specific project.

PART 1.02 REFERENCES

- A. Agency Listings:
1. Intertek ETL.
 2. Canadian Standards Association (CSA).
- B. Safety Standards:
1. Underwriters Laboratories (UL).
 2. Underwriters Laboratories of Canada (ULC).
 3. National Electric Code (NEC).
 4. Canadian Electric Code (CEC).
- C. Air-Conditioning and Refrigerating Institute (ARI):
1. ARI 340/360 Commercial and Industrial Unitary Air-Conditioning and Heat Pump Equipment.
 2. ARI 370 Sound Rating of Large Outdoor Refrigerating and Air Conditioning Equipment.
 3. ARI 210/240 Performance Rating of Unitary Air Conditioning and Air-Source Heat Pump Equipment.
- D. American Society for Testing and Materials (ASTM):
1. ASTM B117 – Standard Practice for Operating Salt Spray.
 2. ASTM 1153 – Standard Method for Methyl Isobutyl Ketone.
- E. ISO 9001, Quality Management Systems.
- F. Meet Military Specification MIL-P-53084

Specifier Note: Article below should be restricted to statements describing design or performance requirements and functional (not dimensional) tolerances of a complete system. Limit descriptions to composite and operational properties required to link components of a system together and to interface with other systems.

PART 1.03 SYSTEM DESCRIPTION

- A. Performance Requirements:

Specifier Note: Article below should be restricted to T-Class (TH), heat pumps packaged roof top units only.

1. [2, 2.5, 3, 4, 5, 6, 7.5, 8.5, 10, 12.5, 15 and 20 ton capacity.]

Specifier Note: Article below should be restricted to T-Class (TG) gas/electric packaged roof top units or T-Class (TC) electric/electric packaged roof top units.

2. [2, 2.5, 3, 4, 5, 6, 7.5, 8.5, 10, 12.5, 15, 17.5, 20 and 25 ton capacity.]
3. Electrical Characteristics:
 - a. 60 Hz

Specifier Note: 208/230 volt 1 phase is only available on 2, 2.5, 3, 4 and 5 ton standard efficiency models. All other voltages are available on 3-25 ton T-Class RTU's.

- b. [208/230 v – 1 Phase] [208/230 v – 3 Phase] [460 v – 3 Phase] [575 v – 3 Phase]

Specifier Note: Article below includes submittal of relevant data to be furnished by Contractor before, during or after construction. Coordinate this article with Architect's and Contractor's duties and responsibilities in Conditions of the Contract and Division 1 Submittal Procedures Section.

PART 1.04 SUBMITTALS

- A. General: Submit listed submittals in accordance with Conditions of the Contract and Division 1 Submittal Procedures.
- B. Product Data: Submit product data for specified products.

GUIDE SPECIFICATIONS

- C. Shop Drawings:
1. Submit shop drawings in accordance with Section 01330 - Submittal Procedures.
 2. Indicate:
 - a. Equipment, piping and connections, together with valves, strainers, control assemblies, thermostatic controls, auxiliaries and hardware, and recommended ancillaries which are mounted, wired and piped ready for final connection to building system, its size and recommended bypass connections.
 - b. Piping, valves and fittings shipped loose showing final location in assembly.
 - c. Control equipment shipped loose, showing final location in assembly.
 - d. Dimensions, internal and external construction details, recommended method of installation with proposed structural steel support, mounting curb details, sizes and location of mounting bolt holes; include mass distribution drawings showing point loads.
 - e. Detailed composite wiring diagrams for control systems showing factory installed wiring and equipment on packaged equipment or required for controlling devices or ancillaries, accessories and controllers.
 - f. Fan performance curves.
 - g. Details of vibration isolation.
 - h. Estimate of sound levels to be expected across individual octave bands in dB.
 - i. Type of refrigerant used.
 - j. Plan view, front view end view, back view and curb detail with dimensions.
- D. Quality Assurance:
1. Test Reports: Certified test reports showing compliance with specified performance characteristics and physical properties.
 2. Certificates: Product certificates signed by manufacturer certifying materials comply with specified performance characteristics and criteria and physical requirements.
 3. Manufacturer's Instructions: Manufacturer's installation instructions.

Specifier Note: Coordinate paragraph below with Part 3 Field Quality Requirements Article herein. Retain or delete as applicable.

- E. Manufacturer's Field Reports: Manufacturer's field reports specified.
- F. Closeout Submittals: Submit following:
1. Warranty: Warranty documents specified.
 2. Operation and Maintenance Data: Operation and maintenance data for installed products in accordance with Division 1 Closeout Submittals (Maintenance Data and Operation Data) Section. Include methods for maintaining installed products and precautions against cleaning materials and methods detrimental to finishes and performance. Include names and addresses of spare part suppliers.
 3. Provide brief description of unit, with details of function, operation, control and component service.
 4. Provide equipment inspection report and equipment operation test report.
 5. Commissioning Report: Submit commissioning reports, report forms and schematics in accordance with Section 01810 - Commissioning.

PART 1.05 QUALITY ASSURANCE

- A. Qualifications:
1. Installer experienced in performing work of this section who has specialized in installation of work similar to that required for this project.

PART 1.06 DELIVERY, STORAGE & HANDLING

- A. General: Comply with Division 1 Product Requirements.
- B. Ordering: Comply with manufacturer's ordering instructions and lead time requirements to avoid construction delays.
- C. Packing, Shipping, Handling and Delivery:
1. Deliver materials in manufacturer's original, unopened, undamaged containers with identification labels intact.
 2. Ship, handle and unload units according to manufacturer's instructions.
- D. Storage and Protection:
1. Store materials protected from exposure to harmful weather conditions.
 2. Factory shipping covers to remain in place until installation.

PART 1.07 PROJECT CONDITIONS

- A. Installation Location: **[Confirm design conditions and temperature.]**

Specifier Note: Coordinate article below with Conditions of the Contract and with Division 1 Closeout Submittals (Warranty).

PART 1.08 WARRANTY

- A. Project Warranty: Refer to Conditions of the Contract for project warranty provisions.
- B. Manufacturer's Warranty: Submit, for Owner's acceptance, manufacturer's standard warranty document executed by authorized company official. Manufacturer's warranty is in addition to, and not a limitation of, other rights Owner may have under Contract Documents.

GUIDE SPECIFICATIONS

Specifier Note: “Aluminized Heat Exchanger” and “Stainless steel Heat Exchanger” limited warranty is only available on T-Class (TG) Gas/Electric models. “Compressor” and “Other System Components” are covered on all T-Class units.

- C. Warranty: Commencing on Date of Installation.
 - 1. Compressors: 5 years (limited).
 - 2. Other Covered System Components: 1 year (limited).
 - 3. [Aluminized Heat Exchangers: 10 years (limited).] [Stainless Steel Heat Exchangers: 15 years (limited).]

PART 2 PRODUCTS

Specifier Note: Retain article below for proprietary method specification. Add product attributes, performance characteristics, material standards and descriptions as applicable. Use of such phrases as “or equal” or “or approved equal” or similar phrases may cause ambiguity in specifications. Such phrases require verification (procedural, legal and regulatory) and assignment of responsibility for determining “or equal” products.

PART 2.01 ROOFTOP UNITS

- A. Manufacturer: Lennox Industries.
 - 1. Contact: 2100 Lake Park Blvd., Richardson, TX 75080; Telephone: (800) 453-6669; website: www.lennox.com.
- B. Proprietary Products/Systems: Lennox T-Class Packaged Rooftop Units, including the following equipment:
 - 1. Cabinet:
 - a. Heavy gauge steel panels.
 - b. Pre-painted steel panels.
 - c. Heavy Gauge galvanized steel base rail.
 - d. Rigging holes on all four corners.
 - e. Forklift slots (on three sides, not directly below condenser coil) on base rail.
 - f. Raised or flanged edges around duct and power entry openings.

Specifier Note: “Down Flow” is the standard configuration that all T-Class units are shipped as.

Specifier Note: “Horizontal Flow” is an option for all T-Class models. T-Class TH, TG and TC models of tonnages 2, 2.5, 3, 4, 5 and 6 can be converted, in the field, to horizontal flow without the need of a conversion kit. If applied horizontally with an economizer, a conversion kit is required.

Specifier Note: “Horizontal Flow” is an option for all T-Class models. T-Class TH, TG and TC models of tonnages 7.5, 8.5, 10 and 12.5 can be converted, in the field, with a separate to Horizontal Conversion Kit.

Specifier Note: “Horizontal Flow” is an option for all T-Class models. T-Class TH, TG and TC models of tonnages 15, 17.5, 20 and 25 require a roof curb that allows for horizontal air flow. A Horizontal Air Panel Kit is also required if converting a down-flow configured unit to horizontal air flow.

- g. [Down-Flow] [Horizontal] Air Flow configuration

Specifier Note: add the “and gas lines” only if using a T-Class (TG) gas/electric model.

- h. Electrical lines [and gas lines] can be brought through the base of the unit or through horizontal knockouts.
- i. Insulation:
 - 1) All panels adjacent to conditioned air are fully insulated with non-hygroscopic fiberglass insulation.
 - 2) Unit base is fully insulated.
 - 3) Unit base insulation also serves as a roof curb seal.
- j. Access Panels:
 - 1) Provided for economizer/filter section.
 - 2) Provided for Heating/blower section.
- k. Condensate Drain Pan.

Specifier Note: “Factory Installed Options” are options that can be selected for the T-Class roof top units. The “Factory Installed Options” are installed at the Lennox manufacturing facility.

- l. [Factory Installed Options:]
 - 1) [Corrosion Protection, meets standards:
 - a) Military Specification MIL-P-53084.
 - b) ASTM B117
 - c) ASTM 1153]
 - 2) [Hinged Access panels]
 - 3) [GFI Service Outlets (field wired)]

Specifier Note: “Field Installed Accessories” are options that can be selected for the T-Class roof top units. The “Field Installed Accessories” are shipped separately and installed in the field.

- m. [Field Installed Accessories:]

GUIDE SPECIFICATIONS

Specifier Note: Of the selections below, [Coil Guards] [Hail Guards], only one can be selected.

- 1) [Coil Guards] [Hail Guards].
- 2) [Horizontal Return Air Panel Kit].

Specifier Note: "Circuit Breakers(up to 175 amps)" is not available on 2-6 ton models.

- 3) [Circuit Breakers (up to 175 amps)]
 - 4) [Disconnect Switch (up to 250 amps)]
 - 5) [Condensate drain trap]
2. Cooling System:
- a. Capable of operating from 30 - 125 degrees F (-1 - 52 degrees C) without installation of additional controls.
 - b. Compressors:

Specifier Note: The TG/TC036B unit uses a reciprocating compressor instead of a scroll type.

- 1) Scroll Type.
 - 2) Resiliently mounted on rubber mounts for vibration isolation.
 - 3) Overload Protected
 - 4) Internal excessive current and temperature protection.
 - 5) Isolated from condenser fan air stream.
 - 6) Refrigerant cooled.
- c. TXV
 - d. Freezestat
 - e. High capacity filter driers

Specifier Note: Include following 2 articles for T-Class (TH) packaged heat pumps models.

- f. Reversing Valves: Four-way interchange reversing valve.
- g. Defrost Control.

Specifier Note: 2-2.5 ton models are only available in Standard efficiency, 3-6 ton models are available in Basic or Standard efficiencies only, and 7.5-20 ton models are available in Standard or High efficiencies only.

Specifier Note: The 12.5 ton model is available in standard efficiency only.

- h. Efficiency: [Basic] [and]/[or] [Standard] [and]/[or] [High].
- i. [Low ambient kit: Field installed]

Specifier Note: High pressure switch is available to be field installed on all units except the T-Class model TH on tonnages 15-20.

- j. [High pressure switch: Field installed]

Specifier Note: Crankcase heater is available to be field installed on all units except the T-Class model TH on tonnages 2-6 and 15-20.

- k. [Crankcase heater: field installed]
3. Coil Construction:
- a. Condensing/evaporator coil general construction:
 - 1) Aluminum Rippled and Lanced fins.
 - 2) Copper tube construction.
 - 3) Aluminum fins mechanically bonded to copper tubes.
 - 4) All coils are high pressure leak tested at manufacturing facility.
 - b. Evaporator Coils:
 - 1) With balanced port thermal expansion valves, freeze protection on each compressor circuit, pressure and leak tested to 500 psi, and maximum 14 fins per inch.
 - 2) Each compressor circuit on coil divided across face of coil and active through full depth of coil.
 - 3) [With flexible immersed coating electrodeposited by dry film process].
 - c. Condenser Coils:
 - 1) [With flexible immersed coating electrodeposited by dry film process] on corrosion hardened units only.

GUIDE SPECIFICATIONS

4. Wiring:
 - a. Color coded and continuously marked to identify point-to-point component connections.
 - b. Not in contact with hot-gas refrigerant lines or sharp metal edges.
5. Cooling Controls:
 - a. Provide minimum compressor on time of 4 minutes.

Specifier Note: “4 Stages of cooling from thermostat” is only available for models that have 4 independent refrigerant circuits. 2-6 ton models have 1 circuit, 7.5-12.5 ton models have 2 circuits, and 15-25 ton models have several models with 4 circuits.

- b. Support up to 4 stages of cooling from thermostat or external DDC controller. (4 independent refrigerant circuits required.)

Specifier Note: T-Class units with Gas Heating Systems are TG models.

6. Gas Heating System:
 - a. Induced draft
 - b. Natural gas fired system with direct spark ignition
 - c. Electronic flame sensors
 - d. Flame rollout switches
 - e. High heat limit switches
 - f. Induced draft failure switch and capable of operating to altitude of 2000 feet (610 m) with no derate to manifold pressure.
 - g. Service access for controls, burners and heat exchanger.
 - h. Heat Exchanger:
 - 1) Tubular Design
 - 2) **[Aluminized steel] [Stainless steel].**
 - i. Gas piping system tight and free of leaks when pressurized to maximum supply pressure.
 - j. Gas Valve: Two-stage, redundant type gas heat valve with manual shutoff.

Specifier Note: One Stage Gas valve only available on 2-6 ton models.

- k. Gas Valve: Single-stage.
 - l. Gas Burners: Aluminized steel inshot-type gas burners.
 - m. Direct spark pilot ignition.
 - n. Fan and Limit Controls.
 - o. Safety Switches.
 - p. Gas piping system tight and free of leaks when.

Specifier Note: “Cold Weather Kit” is only available for field mounting on the T-Class (TG) Gas/Electric models of tonnages 15 – 25 or factory mounting on the T-Class (TG) Gas/Electric models of tonnages 7.5 – 12.

- q. **[Cold Weather Kit:] [field] [factory]**

Specifier Note: “Field Installed Accessories” are options that can be selected for the T-Class TG Gas/Electric models. The “Field Installed Accessories” are shipped separately and installed in the field.

- r. **[Field Installed Accessories:]**
 - 1) **[Combustion Air Intake Extensions].**
 - 2) **[Vertical Vent Extension Kit].**
 - 3) **[LPG/Propane Kit].**

Specifier Note: “Low Temperature Vestibule Heater” is only available for the T-Class (TG) Gas/Electric models of tonnages 2, 2.5, 3, 4, 5 and 6.

- 4) **[Low Temperature Vestibule Heater].**

Specifier Note: The “Electric Heating System” is an option for T-Class (TH), heat pump, and T-Class (TC), electric/electric models only. The “Electric Heating System” can be either factory or field installed.

7. Electric Heating System:
 - a. Electrical resistance heater.
 - b. **[Factory] [Field]** installed.
 - c. **[Factory] [Field]** installed Fuse Block.
 - d. Reset thermal limit protection.
 - e. Single point power supply.
 - f. Heater Element:
 - 1) Nickel chromium wire.
 - 2) Individually fused.

GUIDE SPECIFICATIONS

- g. Electric heater slides out of unit for service.
- 8. Heating Controls:

Specifier Note: 2 stages of heating control are only available on T-Class (TG) gas/electric models of tonnages 4-6, on two stage units.

- a. Support 2 stages of heating control from thermostat or DDC.
- b. With delay time of 30 seconds between low and high heat stages.
- 9. Supply Air Fan Motor and Drives:
 - a. Permanently lubricated ball bearings (for belt drive motors).
 - b. Thermal overload protected motors with automatic reset.

Specifier Note: Slide out accessibility is only available on T-Class models of tonnages 7.5-25.

- c. Adjustable sheaves on belt drive motors for blower speed adjustment.
- d. Optional low and high static motor/drive combinations and optional drive kits.
- 10. Supply Air Fan:
 - a. Double inlet type, G90 (Z275) galvanized steel with forward curved blades.
 - b. Statically and dynamically balanced.
 - c. Slide-out accessibility unit for servicing and belt tension adjustment.
 - d. Continuous or automatic control for occupied periods.
- 11. Supply Air Filters:
 - a. Disposable 2 inch.

Specifier Note: Permanent metal frame filters with 2 inch polyester replaceable media are only available on T-Class models of tonnages 15-25 tons.

- b. [Permanent metal frame filters with 2 inch polyester replaceable media].
- 12. Condenser Fan Motor:

Specifier Note: T-Class 2-4 ton models have sleeve bearings.

- a. Direct drive with permanently lubricated ball bearings.
- b. Watertight with thermal overload protection and automatic reset.
- c. Motor mount isolated from fan safety guard.
- 13. Condenser Fans:
 - a. Corrosion resistant propeller type with vertical discharge and finger safety guard.
- 14. Microprocessor Based Unit Controller System:
 - a. Solid state, microprocessor based control board to control unit cooling operations.
 - b. Green blinking LED to indicate normal operation.
 - c. Pushbutton reset.
 - d. Four-position DIP switch to select unit operating mode/unit type.
 - e. Test mode for quick operation checks.
 - f. Up to 2-stage heat/4-stage cool thermostat or DDC capable thermostat operation.
 - g. Digital Inputs:
 - 1) Low cool demand
 - 2) High cool demand
 - 3) Low heat demand
 - 4) Supply fan demand
 - 5) Primary heat limit (2)
 - 6) Flame rollout switch (2)
 - 7) Induced draft motor switch (2)
 - 8) Gas valve sense switch (2)

Specifier Note: T-Class models of tonnages 15-25 have four Freeze protection switches. 7.5 - 12 ton models have two. 2-6 ton models have one.

- 9) Freeze protection switch (2), (4).
- h. Digital Outputs:
 - 1) Supply air fan motor
 - 2) compressor 1
 - 3) compressor 2
 - 4) condenser fans
 - 5) inducer fan motor 1

Specifier Note: T-Class 7.5 - 25 ton models only.

GUIDE SPECIFICATIONS

- 6) heat 1
- 7) critical diagnostic fault code occurrence.

i. **[Control Options:]**

- 1) **[Single Enthalpy Control] : [Field] [Factory]**
- 2) **[Differential Enthalpy Control : Field]**

Specifier Note: The factory mounted CO2 sensor is only available T-Class models of tonnages 15 - 25. All other models can be field mounted only.

- 3) **[CO2 Sensor:] [Field] [Factory]**

Specifier Note: Economizer Control: Field is only available for T-Class models of tonnages 7.5 - 25.

- 4) **[Economizer Control: Field]**

15. **[Accessories:]**

- a. **[Economizer]: [Field] [Factory]**

Specifier Note: Motorized outdoor air damper is only available in a field mounted version for the T-Class models of tonnages 2, 2.5, 3, 4, 5 and 6. All other models can be factory or field.

- b. **[Motorized outdoor air damper]: [Field] [Factory]**

Specifier Note: Manual outdoor air damper is only available in a field mounted version for the T-Class models of tonnages 2, 2.5, 3, 4, 5 and 6. All other models can be factory or field.

- c. **[Manual outdoor air damper]: [Field] [Factory]**

Specifier Note: Barometric relief damper is included with factory or field installed economizer on 2-6 ton models. All other models can be factory or field installed separately.

- d. **[Barometric relief damper]: [Field] [Factory]**

Specifier Note: The factory mounted Power Exhaust Fan is only available on the versions of T-Class models of tonnages 15-25. All other models can be field mounted.

- e. **[Power exhaust fan]: [Field] [Factory]**

- f. **[Dirty filter switch: Field]**

Specifier Note: The field mounted Blower Proving Switch is only available on T-Class models of tonnages 7.5-25.

- g. **[Blower proving switch]: [Field] [Factory]**

- h. **[Smoke detectors: Field]**

- i. **[Roof curb: Field]**

- j. **[Outdoor air hood: Field]**

- k. **[Barometric relief damper hood: Field]**

Specifier Note: Edit article below to suit project requirements. If substitutions are permitted, edit text below. Add text to refer to Division 1 Project Requirements (Product Substitutions Procedures) Section.

PART 2.02 PRODUCT SUBSTITUTIONS

- A. Substitutions: No substitutions permitted.

PART 3 EXECUTION

PART 3.01 MANUFACTURER'S INSTRUCTIONS

Specifier Note: Revise article below to suit project requirements and specifier's practice.

- A. Compliance: Comply with manufacturer's written data, including product technical bulletins, product catalog installation instructions, product carton installation instructions and manufacturer's SPEC-DATA® sheets.

PART 3.02 EXAMINATION

- A. Site Verification of Conditions: Verify substrate conditions, which have been previously installed under other sections, are acceptable for product installation in accordance with manufacturer's instructions

PART 3.03 INSTALLATION

- A. Install **[Packaged rooftop units] [And] [Commercial packaged, gas/electric, electric/electric and electric/heat pumps]** in accordance with manufacturer's instructions **[On roof curbs provided by manufacturer] [As indicated]**.

END OF SECTION

REVISIONS

Sections	Description of Change
Optional Accessories	Updated Information - Disconnect Switch, Economizer, Gas Piping Kit, High Pressure Switch, Low Ambient Kit.
Gas Heat	Added High Gas Heat to 090-120 model.
Sound Data	Octave Band Sound Power Levels updated.



VERIFIED
ENERGY
PERFORMANCE



VERIFIE
RENDEMENT
ENERGETIQUE



Visit us at www.lennox.com
For the latest technical information, www.lennoxcommercial.com
Contact us at 1-800-4-LENNOX

NOTE - Due to Lennox' ongoing commitment to quality, Specifications, Ratings and Dimensions subject to change without notice and without incurring liability. Improper installation, adjustment, alteration, service or maintenance can cause property damage or personal injury. Installation and service must be performed by a qualified installer and servicing agency.

©2008 Lennox Industries Inc.