

PACKAGED HEAT PUMP



ENGINEERING DATA

TH
T-CLASS™ ROOFTOP UNITS
60HZ

Bulletin No. 210396
July 2008
Supersedes August 2007



**ASHRAE 90.1
COMPLIANT**



7.5 to 12.5 Tons
Net Cooling Capacity - 89,000 - 138,000 Btuh
Optional Electric Heat - 7.5 to 60 kW

MODEL NUMBER IDENTIFICATION

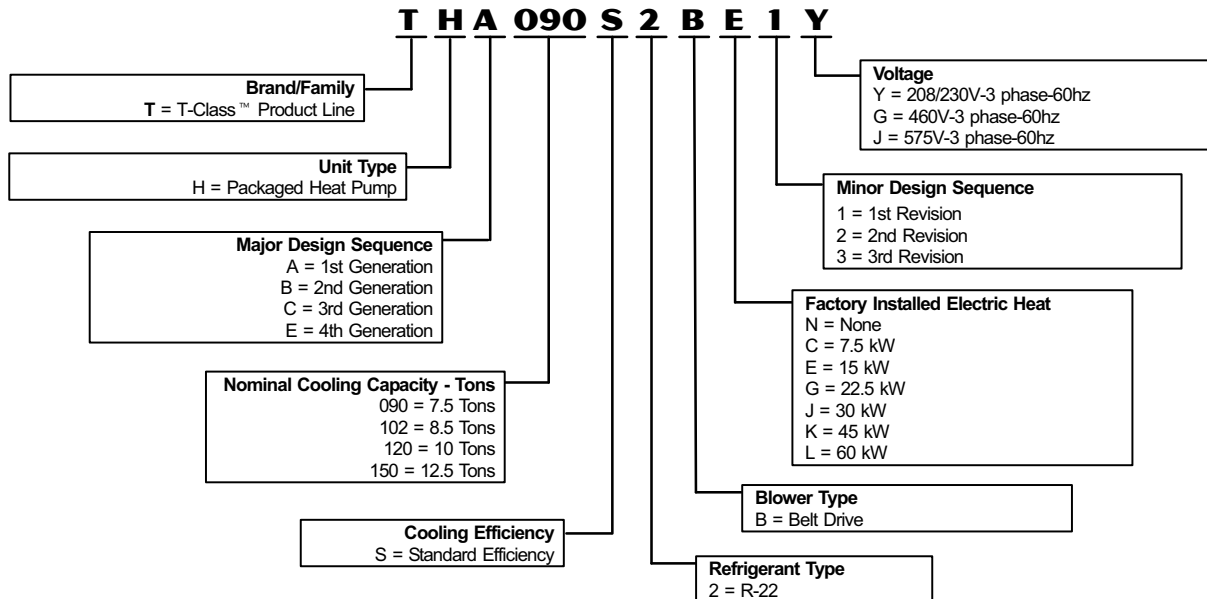

FEATURES AND BENEFITS

Blower Performance	Pages 14-16
Cooling/Heating Ratings	Pages 10-13
Dimensions	Pages 24-29
Electrical/Electric Heat Data	Pages 17-19
Features and Benefits	Pages 2-4
Guide Specifications	Pages 31-37
Installation Clearances	Page 21
Model Number Identification	Page 1
Optional Accessories	Pages 5-7
Specifications	Page 9
Sound Data	Page 21
Temperature Control Systems	Page 22
Weights	Page 23

CERTIFICATIONS

ETL and CSA listed. Components bonded for grounding to meet safety standards for servicing required by UL, CSA and National and Canadian Electrical Codes. Gas efficiency ratings verified by CSA. Cooling performance certified in accordance with the ULE certification program, which is based on ARI Standard 340/360-2000. ISO 9001 Registered Manufacturing Quality System.

ENERGY STAR® certified units are designed to use less energy, help save money on utility bills, and help protect the environment.

The ENERGY STAR® Partner of the Year Award signifies that Lennox has made outstanding contributions to design energy efficient units that will lower energy bills, while meeting industry standards for comfort and indoor air quality. Lennox was the first HVAC manufacturer to win this award and has received the award three years in a row.

WARRANTY

Limited five years on compressors.
Limited one year all other covered components.

COOLING / HEATING SYSTEM

Designed to maximize sensible and latent cooling performance at design conditions. Two efficiency levels provide flexibility. System can operate from 30°F to 125°F without any additional controls.

1 Compressors

Resiliently mounted on rubber grommets for quiet operation. Scroll compressors on all models for high performance, reliability and quiet operation.

Compressor Crankcase Heaters

Protects against refrigerant migration that can occur during low ambient operation.

Thermal Expansion Valves

Assures optimal performance throughout the application range. Removable element head.

Filter/Driers

High capacity filter/driers protect the system from dirt and moisture.

T-Class Packaged Heat Pump 7.5 to 12 tons / Page 2

Freezestats

Protects the evaporator coil from damaging ice build-up due to conditions such as low/no air flow, or low/no refrigerant charge.

2 Coil Construction

Copper tube construction, enhanced rippled-edge aluminum fins, flared shoulder tubing connections, silver soldered construction for improved heat transfer. Factory leak tested.

Evaporator Coil

Face split with separate circuits. Each circuit has its separate expansion valve, compressor and refrigerant charge. Enhanced aluminum fins and copper tube coils with cross row circuiting optimizes both sensible and latent cooling capacity.

Condenser Coil

Formed type on all models. Ripple-edged, enhanced aluminum fin and copper tube construction maximizes heat transfer capability.

Condensate Drain Pan

Painted, galvanized pan with positive slope.

Drain connection extends outside unit.

Outdoor Coil Fan Motors

Thermal overload protected, totally enclosed, permanently lubricated ball bearings, shaft up, independent motor mount.

Outdoor Coil Fan

PVC coated fan guard furnished.

Defrost Control

Provides a defrost cycle, if needed, every 30 or 60 or 90 minutes (adjustable) of compressor "on" time at outdoor coil temperature below 35°F. Pressure switch mounted on outdoor coil vapor line terminates defrost cycle.

3 Reversing Valves

4-way interchange reversing valve effects a rapid change in direction of refrigerant flow resulting in quick changeover from cooling to heating and vice versa.

REQUIRED SELECTIONS

Cooling Capacity

Specify the nominal cooling capacity of the unit.

Cooling Efficiency

Specify either standard or high efficiency.

OPTIONS/ACCESSORIES

Field Installed

Condensate Drain Trap

Available in copper or PVC.

High Pressure Switches

Protects the compressor from overload conditions such as dirty condenser coils, blocked refrigerant flow, or loss of outdoor fan operation. Manual reset.

Low Ambient Kit

Cycles the outdoor fan while allowing compressor operation in the cooling cycle. This intermittent fan operation allows the system to operate without icing the evaporator coil and losing capacity. Designed for use in ambient temperatures no lower than 0°F.

4 BLOWER

Supply air fan provides a wide range of air flow capability. Special order high and low static motor and drive options are available offering an even wider range of capability.

Supply Air Motor

Overload protected with permanently lubricated ball bearings ensures durable operation. Belt drive motors that meet EPACT efficiency requirements maximize air performance and save energy. Special order high and low static motors provide a higher level of air performance for demanding applications.

Supply Air Blower

A double inlet wheel with forward curve blades provide maximum air performance and quiet operation. Dynamically balanced with permanently lubricated ball bearings assure long, reliable operation. Adjustable pulleys allow air to be precisely tuned to the needs of the application.

REQUIRED SELECTIONS

Supply Air Blower

Specify Blower motor and drive kit (See Blower Data Table for specifications).

OPTIONS/ACCESSORIES

Factory Installed

High and Low Static Supply Fan

Extends air flow external static range.

FEATURES AND BENEFITS

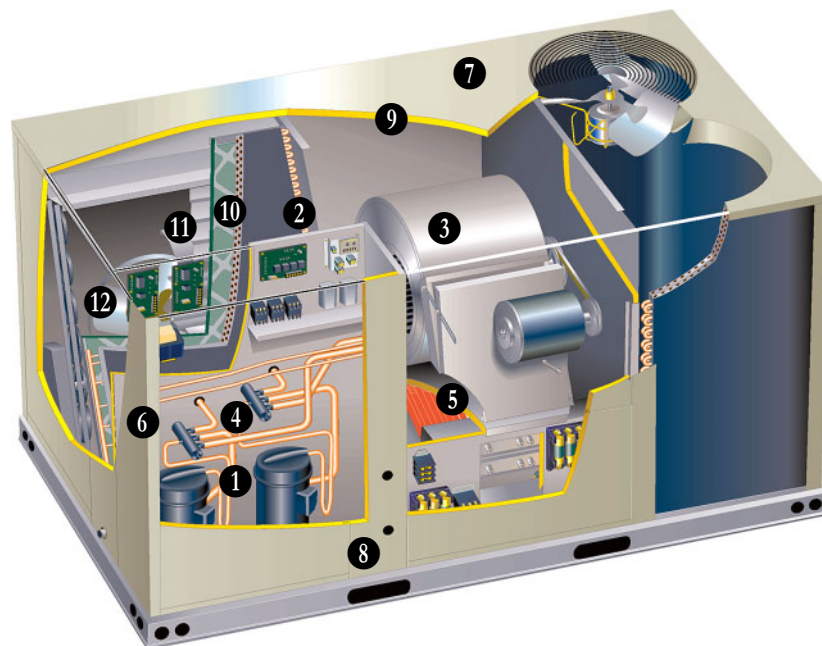

CONTROLS

Unit Controller

Solid-state microprocessor-based control board that provides flexible control of cooling functions. All control voltage is provided via a 24V (secondary) transformer with built-in circuit breaker protection. Built-in functions include:

Blower On/Off Delay - Time delay between blower on and off cycles provides a more even supply air temperature during heating.

Built-in Control Parameters - Saves installation time as no programming is required.

Minimum Compressor Run Time - Ensures proper oil return to the compressor.

Night Setback Mode - Saves energy by closing outdoor air dampers and operating supply fan on thermostat demand only.

Heat/Cool Staging - Capable of up to 2 heat / 2 cool staging with a third party DDC control system or compatible thermostat.

Thermostat Bounce Delay - Protects compressor from short cycling when a mechanical thermostat is used.

OPTIONS/ACCESSORIES

Field Installed

Blower Proving Switch

Uses a static pressure sensor to monitor blower operation and shuts down unit if blower fails.

Dirty Filter Switch

Senses static pressure increase indicating dirty filter condition.

Smoke Detector

Photoelectric type, installed in supply air section or return air section or both sections

Commercial Control Systems

L Connection® Network

Complete building automation control system for single or multi-zone applications. Options include local interface, software for local or remote communication, and hardware for networking other control functions. See L Connection Network Engineering Handbook Bulletin for details.

Thermostats

Control system and thermostat options. Aftermarket unit controller options. See Page 22.

ELECTRICAL

REQUIRED SELECTIONS

Voltage Choice

Specify 208/230V, 460V or 575V 3-phase-60hz when ordering base unit.

OPTIONS/ACCESSORIES

Factory or Field Installed

5 Electric Heat

Helix wound nichrome elements, individual element limit controls, wiring harness. Unit Fuse Block must be ordered extra. See Electrical/Electric Heat tables for ordering information, Pages 17-19.

GFI Service Outlets (2)

115v ground fault circuit interrupter (GFCI) type, field wired.

Field Installed

6 Circuit Breakers up to 175 Amp

HACR circuit breaker without power distribution lugs. Accessible from outside of unit, spring-loaded weatherproof cover furnished. Main power to the unit is field connected to the circuit breaker which allows all power to be shutoff for service. Circuit breaker is sized to the unit maximum overcurrent protection (MOCP) size.

Disconnect Switch up to 250 Amp

Accessible from outside of unit, spring loaded weatherproof cover furnished. Main power to the unit is field connected to the disconnect which allows all power to be shut off for service.

FEATURES AND BENEFITS

CABINET

7 Construction

Heavy-gauge steel panels and full perimeter heavy-gauge galvanized steel base rail provides structural integrity for transportation, handling, and installation. Base rails have rigging holes. Three sides of the base rail have fork slots. Raised edges around duct and power entry openings in the bottom of the unit provide additional protection against water entering the building.

Air-Flow Choice

Units are available in down-flow (vertical) or horizontal air flow configuration with optional field installed Horizontal Conversion Kit.

Duct Flanges

Horizontal supply duct flange is standard on all units.

8 Power Entry

Electrical lines can be brought through the unit base or through horizontal access knock-outs.

Exterior Panels

Constructed of heavy-gauge, galvanized steel with a two-layer enamel paint finish. Large removable panels provide service access.

9 Insulation

All panels adjacent to conditioned air are fully insulated with non-hygroscopic fiberglass insulation. Unit base is fully insulated. The insulation also serves as an air seal to the roof curb, eliminating the need to add a seal during installation.

Access Panels

Access panels are provided for the economizer/filter section, blower section, heating section and the compressor/controls section.

REQUIRED SELECTIONS

Air Flow Configuration

Specify horizontal or down-flow (vertical).

OPTIONS/ACCESSORIES

Factory Installed

Corrosion Protection

A completely flexible immersed coating with an electrodeposited dry film process. (AST ElectroFin E-Coat) Meets Mil Spec MIL-P-53084, ASTM B117 Standard Method Salt Spray Testing, ASTM 1153 Standard Specification for Methyl Isobutyl Ketone.

Hinged Access Panels

Large access panels are hinged and have quarter-turn latches for quick and easy access to maintenance areas (economizer / filter, compressor / controls, heating / blower).

Field Installed

Coil Guards

Painted, galvanized steel wire guards to protect outdoor coil. Not used with Hail Guards.

Hail Guards

Constructed of heavy gauge steel, painted to match cabinet, helps protect outdoor coils from hail damage. Not used with Coil Guards.

Horizontal Return Air Panel Kit

Required for horizontal applications with Horizontal Roof Curb, contains panel with return air opening for field replacement of existing unit panel and panel to cover bottom return air opening in unit, see dimension drawings.

INDOOR AIR QUALITY

10 Air Filters

Disposable 2 inch filters furnished as standard.

OPTIONS/ACCESSORIES

Field Installed

Indoor Air Quality (CO₂) Sensor

Monitors CO₂ levels.

SERVICEABILITY

Designed to streamline general maintenance and decrease troubleshooting time.

Marked & Color-Coded Wiring

All electrical wiring is color-coded and marked to identify which components it is connecting.

Electrical Plugs

Positive connection electrical plugs are used to connect common accessories or maintenance parts for easy removal or installation.

Access Panels

Large access panels are provided for quick and easy access to maintenance areas.

Blower Access

Blower assembly slides out of the unit for easy access.

TXV Access

Thermal expansion valves are located near the perimeter of the unit for easier access.

Thermal Expansion Valves

Removable element head allows change out of element and bulb without removing the TXV.

Coil Cleaning

Independently formed condenser coils allow separation for easier cleaning.

Standard Components

A large number of common maintenance parts are standard throughout the entire range of sizes (7.5 - 12.5 tons), reducing the need to carry a lot of different parts to the job or in inventory.

Compressor Access

Compressors are located near the perimeter of the unit for easier access.

Compressor Compartment

Compressors are isolated from the condenser air flow allowing system operation checks to be done without changing the air flow across the outdoor coils.

OPTIONS / ACCESSORIES

ECONOMIZER/OUTDOOR AIR/EXHAUST ACCESSORIES

Factory or Field Installed

11 Economizer

Parallel, gear-driven action return air and outdoor air dampers, plug-in connections to unit, nylon bearings, neoprene seals, 24 volt, spring return motor, adjustable minimum damper position, damper assembly slides in unit, outdoor air hood must be ordered separately, choice of economizer controls. Economizer modulates dampers to maintain a 55°F discharge air temperature.

Economizer Enthalpy Control

Senses outdoor air enthalpy and enables economizer if the enthalpy is less than the setpoint of the control.

Down-Flow Barometric Relief Dampers

Allows relief of excess return air static when economizer is near full open. Aluminum blade dampers prevent blow back and outdoor air infiltration during off cycle. Bird screen furnished.

Outdoor Air Damper Section

25% Manual Outdoor Air Dampers - Parallel blade dampers are manually adjustable to a fixed position.

25% Automatic Outdoor Air Damper - Parallel blade, gear-driven dampers are automatically adjusted with a two-position damper motor.

Economizer and Outdoor Air Damper

Application Note - Minimum mixed air temperature in heating mode 30°F
Maximum mixed air temperature in cooling mode: 90°F

12 Power Exhaust Fans

Installs internal to unit for down-flow applications with economizer option. Provides exhaust air pressure relief. Interlocked to run when supply air blower is operating. Fan runs when outdoor air dampers are 50% open (adjustable). Motor is overload protected. Galvanized steel cabinet and hood painted to match unit. Total air volume is 4200 cfm at 0 in. wg. 1/3 hp motor. 300 Watts total input. See Power Exhaust Blower Tables.

Field Installed

Economizer Control

Sensible Control - Senses outdoor air temperature and enables the economizer if the temperature is less than the set point of the control.

Differential Sensible Control - Two temperature sensors allow the control to select between outdoor air or return air, whichever has lower temperature.

Enthalpy Control - Senses outdoor air enthalpy and enables economizer if the enthalpy is less than the setpoint of the control.

Differential Enthalpy Control - Two solid-state enthalpy sensors allow the control to select between outdoor air or return air, whichever has lower enthalpy.

Economizer Modulating Sensor Kit - Sensor that allows the economizer damper to modulate to maintain 55°F discharge air temperature, while in free-cooling.

Outdoor Air Hood

Required with Economizer, Outdoor Air Damper Sections, cleanable aluminum mesh fresh air filters furnished.

Down-Flow Barometric Relief Damper Hood

Protects exhaust air from recirculating into outdoor air stream.

Horizontal Barometric Relief Dampers

Allows relief of excess air when economizer is near full open. Aluminum blade dampers prevent blow back and outdoor air infiltration during off cycle. Field installed in return air duct. Bird screen furnished.

CEILING DIFFUSERS

OPTIONS/ACCESSORIES

Field Installed

Ceiling Diffusers

Aluminum grilles, large center grille, insulated diffuser box with flanges, hanging rings furnished, interior transition (even air flow), internally sealed (prevents recirculation), adapts to T-bar ceiling grids or plaster ceilings.

Transitions (Supply and Return) - Used with diffusers, installs in roof curb, galvanized steel construction, flanges furnished for duct connection to diffusers, fully insulated.

ROOF CURBS

OPTIONS/ACCESSORIES

Field Installed

Nailer strip furnished, mates to unit, US National Roofing Contractors Approved, shipped knocked down. Available in 8, 14, 18, and 24 inch heights.

Cliplock curbs use interlocking tabs to fasten together. No tools required.

Standard roof curb corners fasten together with furnished hardware.

OPTIONS / ACCESSORIES

Item	Catalog No.	090	102	120	150	
COOLING / HEATING SYSTEM						
Condensate Drain Trap	PVC - LTACDKP09-36	37K90	x	x	x	x
	Copper - LTACDKC09-36	48K14	x	x	x	x
Corrosion Protection			○	○	○	○
Efficiency	Standard		○	○	○	○
High Pressure Switch	T1SNSR11B-2	42W97	x	x	x	x
Low Ambient Kit	T1SNSR13B-2	42W99	x	x	x	x
Refrigerant Type	R-22		○	○	○	○
BLOWER - SUPPLY AIR						
Constant Air Volume	2 hp Standard or High Efficiency		○	○	○	
	3 hp Standard Efficiency		○	○	○	○
	3 hp High Efficiency		○	○	○	○
	5 hp Standard or High Efficiency				○	○
CABINET						
Coil Guards	TACGKGC10/15	69M44	x	x	x	x
Hail Guards	TAHGKGC10/15	69M45	x	x	x	x
Hinged Access Panels			○	○	○	○
Horizontal Discharge Conversion Kit	LTHSDKGC10/15	56K53	x	x	x	x
CONTROLS						
Blower Proving Switch	C0SWCH01AE1-	30K49	x	x	x	x
Dirty Filter Switch	C0SWCH00AE1-	30K48	x	x	x	x
Smoke Detector - Supply	LTSASDK10/36	70K87	x	x	x	x
Smoke Detector - Return	LTARSDK10/30	70K86	x	x	x	x
ECONOMIZER						
Economizer						
Economizer - Order LAOAH Hood Separately	TAREMD10/15	94M02	⊗	⊗	⊗	⊗
Economizer Controls						
Differential Enthalpy (dual)	C1SNSR07AE	86M33	x	x	x	x
Sensible (order two kits for Differential)	TASEK10/15	76M37	⊗	⊗	⊗	⊗
Single Outdoor Enthalpy	C1SNSR06AE	86M32	x	x	x	x
Barometric Relief						
Down-Flow Barometric Relief Dampers - Order Hood Separately	LAGED10/15	53K03	⊗	⊗	⊗	⊗
Hood for Down-Flow LAGED	LAGEH09/15	88K79	x	x	x	x
Horizontal Barometric Relief Dampers Hood Furnished	LAGEDH03/15	53K04	x	x	x	x
OUTDOOR AIR						
Outdoor Air Dampers						
Damper Section (down-flow) Order Hood Separately	Motorized - TAOADM10/15	73M74	⊗	⊗	⊗	⊗
	Manual - LAOAD10/15	66K69	⊗	⊗	⊗	⊗
Outdoor Air Hoods for Economizers and Outdoor Air Dampers						
Outdoor Air Hood (2 each) 16 x 25 x 1 in.	LAOAH10/15	53K05	⊗	⊗	⊗	⊗
POWER EXHAUST FANS						
Standard Static	208/230V - LAPEF10/15	73M32	⊗	⊗	⊗	⊗
	460V - LAPEF10/15	73M33	⊗	⊗	⊗	⊗
	575V - LAPEF10/15	73M35	⊗	⊗	⊗	⊗

NOTE - The catalog and part numbers that appear here are for ordering field installed accessories only.

⊗ - Field Installed or Configure to Order (factory installed)

○ - Configure to Order (Factory Installed)

X - Field Installed.

OPTIONS / ACCESSORIES

Item	Catalog No.	090	102	120	150
ELECTRICAL					
Voltage 60 hz	208/230V - 3 phase	○	○	○	○
	460V - 3 phase	○	○	○	○
	575V - 3 phase	○	○	○	○
HACR Circuit Breakers	25 to 80 Amp size available	x	x	x	x
Disconnect Switch	See Electrical/Electric Heat Tables for selection	x	x	x	x
GFI Service Outlets	LTAGFIK10/15 74M70	⊗	⊗	⊗	⊗
ELECTRIC HEAT					
7.5 kW	EHA102-7.5 - 208/230V-3ph 99J01	⊗	⊗		
	460V-3ph 99J02	⊗	⊗		
	575V-3ph 99J03	⊗	⊗		
15 kW	EHA150-15 - 208/230V-3ph 99J04	⊗	⊗	⊗	⊗
	460V-3ph 99J05	⊗	⊗	⊗	⊗
	575V-3ph 99J06	⊗	⊗	⊗	⊗
22.5 kW	EHA360-22.5 - 208/230V-3ph 99J28	⊗	⊗	⊗	⊗
	460V-3ph 99J29	⊗	⊗	⊗	⊗
	575V-3ph 99J30	⊗	⊗	⊗	⊗
30 kW	EHA150-30 - 208/230V-3ph 99J07	⊗	⊗	⊗	⊗
	460V-3ph 99J08	⊗	⊗	⊗	⊗
	575V-3ph 99J09	⊗	⊗	⊗	⊗
45 kW	EHA150-45 - 208/230V-3ph 99J10	⊗	⊗	⊗	⊗
	460V-3ph 99J11	⊗	⊗	⊗	⊗
	575V-3ph 99J12	⊗	⊗	⊗	⊗
60 kW	EHA150-60 - 208/230V-3ph 99J13			⊗	⊗
	460V-3ph 99J14			⊗	⊗
	575V-3ph 99J15			⊗	⊗
ELECTRIC HEAT ACCESSORIES/OPTIONS - See Electrical/Electric Heat Tables for selection					
LTB2 Terminal Block	LTB2-175 30K75	⊗	⊗	⊗	⊗
	LTB2-335 30K76	⊗	⊗	⊗	⊗
¹ Electric Heat Control Module	TAEK10/15 73M79	⊗	⊗	⊗	⊗
Unit Fuse Block		⊗	⊗	⊗	⊗
INDOOR AIR QUALITY					
Indoor Air Quality (CO₂) Sensors					
CO ₂ Sensor Duct Mounting Kit	C0MISC19AE1- 85L43	x	x	x	x
Sensor - white case CO ₂ display	C0SNSR50AS1L 77N39	x	x	x	x
Sensor - white case no display	C0SNSR52AS1L 87N53	x	x	x	x
Sensor - black case CO ₂ display	C0SNSR51AS1L 87N52	x	x	x	x
Sensor - black case, no display	C0SNSR53AS1L 87N54	x	x	x	x
Aspiration Box for duct mounting	C0MISC16AE1- 90N43	x	x	x	x
Handheld CO ₂ Monitor	LTIAIQSHM03/36 70N93	x	x	x	x

NOTE - The catalog and part numbers that appear here are for ordering field installed accessories only.

⊗ - Field Installed or Configure to Order (factory installed)

○ - Configure to Order (Factory Installed)

x - Field Installed.

¹ Required with all models.

OPTIONS / ACCESSORIES

Item	Item	Catalog No.	090	102	120	150
CEILING DIFFUSERS						
Step-Down Order one	RTD11-95	29G04	x			
	RTD11-135	29G05		x	x	
	RTD11-185	29G06				x
	(Canada Only) RTD11-150/180S	13K63				x
Flush Order one	FD11-95	29G08	x			
	FD11-135	29G09		x	x	
	FD11-185	29G10				x
	(Canada Only) FD11-150/180S	13K58				x
Transitions (Supply and Return) Order one	LASRT10/12	49K55	x	x	x	
	LASRT15	49K56				x
ROOF CURBS - CLIPLOCK 1000						
Down-Flow						
8 in. height	C1CURB40B	26W31	x	x	x	x
14 in. height	LARMF10/15S-14	65K34	x	x	x	x
18 in. height	LARMF10/15S-18	65K35	x	x	x	x
24 in. height	LARMF10/15S-24	65K36	x	x	x	x
ROOF CURBS - STANDARD						
Down-Flow						
14 in. height	LARMF10/15-14	53K50	x	x	x	x
24 in. height	LARMF10/15-24	49K54	x	x	x	x

NOTE - The catalog and part numbers that appear here are for ordering field installed accessories only.

⊗ - Field Installed or Configure to Order (factory installed)

X - Field Installed.

SPECIFICATIONS

General Data		Nominal Tonnage	7.5 Ton	8.5 Ton	10 Ton	12.5 Ton
		Model No.	THA090S2B	THA102S2B	THA120S2B	THA150S2B
		Efficiency Type	Standard	Standard	Standard	Standard
Cooling Performance	Gross Cooling Capacity - Btuh		93,000	104,000	126,000	145,000
	¹ Net Cooling Capacity - Btuh		89,000	100,000	118,000	138,000
	ARI Rated Airflow - cfm		3000	3500	4200	4400
	Total Unit Power		8.8	9.9	11.8	14.8
	¹ EER (Btuh/Watt)		10.1	10.1	10.1	9.3
	² Integrated Part Load Value (Btuh/Watt)		10.5	10.5	10.5	10.5
	Refrigerant Charge	Circuit 1	12 lbs. 0 oz.	11 lbs. 0 oz.	12 lbs. 8 oz.	11 lbs. 8 oz.
	Furnished (HCFC-22)	Circuit 2	10 lbs. 10 oz.	11 lbs. 0 oz.	12 lbs. 8 oz.	11 lbs. 8 oz.
³ Sound Rating Number (dB)			88	88	88	88
Heating Performance	¹ Total High Heating Capacity - Btuh		90,000	102,000	120,000	136,000
	Total Unit Power		8.3	9.3	11.0	13.2
	¹ C.O.P.		3.2	3.2	3.2	3.1
	¹ Total Low Heating Capacity - Btuh		52,000	56,000	72,000	80,000
	Total Unit Power		7.1	7.5	9.5	11.7
	¹ C.O.P.		2.2	2.2	2.2	2.0
Compressor - Number & Type			(2) Scroll	(2) Scroll	(2) Scroll	(2) Scroll
Outdoor Coil	Net face area - sq. ft.		29.3 total	29.3 total	29.3 total	29.3 total
	Tube diameter - in.		3/8	3/8	3/8	3/8
	Number of rows		2	2	2	2
	Fins per inch		20	20	20	20
Outdoor Coil Fans	Motor horsepower		(2) 1/3	(2) 1/3	(2) 1/3	(2) 1/2
	Motor rpm		1075	1075	1075	1075
	Total Motor watts		700	700	700	1050
	Diameter - in. - no. of blades		(2) 24 - 3	(2) 24 - 3	(2) 24 - 3	(2) 24 - 3
	Total air volume - cfm		8000	8000	8000	10,000
Indoor Coil	Net face area - sq. ft.		10.5 total	10.5 total	10.5 total	10.5 total
	Tube diameter - in.		3/8	3/8	3/8	3/8
	Number of rows		3	3	4	4
	Fins per inch		14	14	14	14
	Drain Connection - no. & size		(1) 1 in. NPT cplg	(1) 1 in. NPT cplg	(1) 1 in. NPT cplg	(1) 1 in. NPT cplg
Expansion device type			Balanced Port Thermostatic Expansion Valve, removeable power head			
Standard Indoor Blower and Drive	⁴ Belt Drive - Nominal motor output		2 hp	2 hp	3 hp	5 hp
	Maximum usable output (US Only)		2.3 hp	2.3 hp	3.45 hp	5.75 hp
	Drive kit		kit #1 680 - 925 rpm	kit #1 680 - 925 rpm	kit #3 895 - 1120 rpm	kit #6 1100 - 1395 rpm
	Wheel nominal diameter x width - in.		(1) 15 x 15	(1) 15 x 15	(1) 15 x 15	(1) 15 x 15
Filters	Type of filter		Disposable			
	Number and size - in.		(4) 18 x 24 x 2	(4) 18 x 24 x 2	(4) 18 x 24 x 2	(4) 18 x 24 x 2
Electrical characteristics			208/230V, 460V or 575V - 60 hertz - 3 phase			

NOTE - Net capacity includes evaporator blower motor heat deduction. Gross capacity does not include evaporator blower motor heat deduction.

¹ Certified in accordance with the ULE certification program, which is based on ARI Standard 340/360.

Cooling Ratings - 95°F outdoor air temperature and 80°F db/67°F wb entering indoor coil air.

High Temperature Heating Ratings - 47°F db/43°F wb outdoor air temperature and 70°F entering indoor coil air.

Low Temperature Heating Ratings - 17°F db/15°F wb outdoor air temperature and 70°F entering indoor coil air.

² Integrated Part Load Value rated at 80°F outdoor air temperature, 80°F db/67°F wb indoor air temperature.

³ Sound Rating Number rated in accordance with test conditions included in ARI Standard 270.

⁴ Maximum usable output of motors furnished by Lennox are shown. In Canada, nominal motor output is also maximum usable motor output. If motors of comparable output are used, be sure to keep within the service factor limitations outlined on the motor nameplate.

COOLING & HEATING RATINGS

7.5 TON

NOTE - For Temperatures and Capacities not shown in tables, see bulletin - Cooling Unit Rating Table Correction Factor Data in Miscellaneous Engineering Data section.

7.5 TON STANDARD EFFICIENCY - COOLING CAPACITY - ONE COMPRESSOR OPERATING

THA090S

Entering Wet Bulb Temperature	Total Air Volume		Outdoor Air Temperature Entering Outdoor Coil																							
			65°F (18°C)						75°F (24°C)						85°F (29°C)						95°F (35°C)					
	cfm	L/s	Total Cooling Capacity		Comp Motor kW Input	Sensible To Total Ratio (S/T) Dry Bulb			Total Cooling Capacity		Comp Motor kW Input	Sensible To Total Ratio (S/T) Dry Bulb			Total Cooling Capacity		Comp Motor kW Input	Sensible To Total Ratio (S/T) Dry Bulb			Total Cooling Capacity		Comp Motor kW Input	Sensible To Total Ratio (S/T) Dry Bulb		
			kBtuh	kW		75°F 24°C	80°F 27°C	85°F 29°C	kBtuh	kW		75°F 24°C	80°F 27°C	85°F 29°C	kBtuh	kW		75°F 24°C	80°F 27°C	85°F 29°C	kBtuh	kW		75°F 24°C	80°F 27°C	85°F 29°C
63°F (17°C)	2400	1135	47.1	13.8	2.47	.67	.81	.95	45.8	13.4	2.80	.68	.83	.97	44.3	13.0	3.17	.69	.84	.98	42.8	12.5	3.58	.70	.86	.99
	3000	1415	49.0	14.4	2.49	.72	.89	1.00	47.6	14.0	2.81	.73	.91	1.00	46.1	13.5	3.17	.75	.92	1.00	44.5	13.0	3.59	.76	.94	1.00
	3600	1700	50.5	14.8	2.50	.78	.96	1.00	49.1	14.4	2.82	.79	.97	1.00	47.5	13.9	3.18	.81	.98	1.00	46.0	13.5	3.60	.82	1.00	1.00
67°F (19°C)	2400	1135	50.2	14.7	2.49	.53	.65	.78	48.7	14.3	2.82	.53	.66	.79	47.2	13.8	3.18	.54	.66	.80	45.5	13.3	3.60	.54	.68	.82
	3000	1415	51.9	15.2	2.50	.56	.70	.85	50.3	14.7	2.83	.56	.71	.87	48.7	14.3	3.19	.57	.72	.89	47.0	13.8	3.60	.57	.73	.91
	3600	1700	53.0	15.5	2.51	.58	.75	.93	51.4	15.1	2.83	.59	.77	.94	49.8	14.6	3.20	.60	.78	.96	48.0	14.1	3.61	.61	.80	.97
71°F (22°C)	2400	1135	53.6	15.7	2.51	.40	.51	.62	52.0	15.2	2.84	.40	.52	.63	50.4	14.8	3.20	.40	.52	.64	48.6	14.2	3.62	.41	.53	.65
	3000	1415	55.2	16.2	2.53	.41	.54	.67	53.6	15.7	2.85	.41	.55	.68	51.8	15.2	3.21	.41	.55	.70	50.0	14.7	3.62	.42	.56	.71
	3600	1700	56.4	16.5	2.54	.42	.57	.73	54.6	16.0	2.86	.42	.58	.74	52.8	15.5	3.22	.43	.59	.76	51.0	14.9	3.63	.43	.60	.77

7.5 TON STANDARD EFFICIENCY - COOLING CAPACITY - ALL COMPRESSORS OPERATING

THA090S

Entering Wet Bulb Temperature	Total Air Volume		Outdoor Air Temperature Entering Outdoor Coil																							
			85°F (29°C)						95°F (35°C)						105°F (41°C)						115°F (46°C)					
	cfm	L/s	Total Cooling Capacity		Comp Motor kW Input	Sensible To Total Ratio (S/T) Dry Bulb			Total Cooling Capacity		Comp Motor kW Input	Sensible To Total Ratio (S/T) Dry Bulb			Total Cooling Capacity		Comp Motor kW Input	Sensible To Total Ratio (S/T) Dry Bulb			Total Cooling Capacity		Comp Motor kW Input	Sensible To Total Ratio (S/T) Dry Bulb		
			kBtuh	kW		75°F 24°C	80°F 27°C	85°F 29°C	kBtuh	kW		75°F 24°C	80°F 27°C	85°F 29°C	kBtuh	kW		75°F 24°C	80°F 27°C	85°F 29°C	kBtuh	kW		75°F 24°C	80°F 27°C	85°F 29°C
63°F (17°C)	2400	1135	87.1	25.5	6.24	.70	.84	.97	84.1	24.6	7.06	.71	.86	.99	80.9	23.7	7.97	.72	.88	1.00	77.4	22.7	9.02	.74	.90	1.00
	3000	1415	90.6	26.6	6.26	.75	.92	1.00	87.4	25.6	7.08	.77	.94	1.00	84.1	24.6	7.99	.78	.96	1.00	80.7	23.7	9.04	.80	.97	1.00
	3600	1700	93.4	27.4	6.28	.81	.98	1.00	90.4	26.5	7.10	.82	.99	1.00	87.1	25.5	8.01	.84	1.00	1.00	83.9	24.6	9.07	.87	1.00	1.00
67°F (19°C)	2400	1135	92.8	27.2	6.27	.55	.68	.81	89.5	26.2	7.09	.55	.69	.82	86.1	25.2	8.01	.56	.70	.84	82.4	24.1	9.06	.57	.71	.86
	3000	1415	95.8	28.1	6.29	.58	.73	.88	92.4	27.1	7.11	.58	.74	.90	88.7	26.0	8.03	.59	.76	.92	84.9	24.9	9.08	.60	.78	.94
	3600	1700	97.9	28.7	6.31	.61	.78	.95	94.4	27.7	7.12	.62	.80	.97	90.7	26.6	8.05	.63	.82	.98	86.7	25.4	9.09	.64	.84	1.00
71°F (22°C)	2400	1135	99.1	29.0	6.31	.41	.53	.65	95.6	28.0	7.14	.41	.54	.66	92.0	27.0	8.05	.42	.54	.67	88.1	25.8	9.10	.42	.55	.69
	3000	1415	102.0	29.9	6.33	.42	.56	.70	98.4	28.8	7.15	.42	.57	.72	94.6	27.7	8.08	.43	.58	.73	90.5	26.5	9.12	.43	.59	.75
	3600	1700	104.0	30.5	6.35	.43	.60	.76	100.3	29.4	7.16	.44	.61	.78	96.4	28.3	8.09	.44	.62	.80	92.1	27.0	9.14	.45	.63	.82

7.5 TON STANDARD EFFICIENCY - HEATING CAPACITY

THA090S

Indoor Coil Air Volume 70°F db (21°C db)	Air Temperature Entering Outdoor Coil															
	65°F (18°C)			45°F (7°C)			25°F (-4°C)			5°F (-15°C)			-15°F (-26°C)			
	cfm	L/s	Total Heating Capacity kBtuh	kW	Comp. Motor kW Input	Total Heating Capacity kBtuh	kW	Comp. Motor kW Input	Total Heating Capacity kBtuh	kW	Comp. Motor kW Input	Total Heating Capacity kBtuh	kW	Comp. Motor kW Input	Total Heating Capacity kBtuh	kW
2400	1135	111.2	32.6	8.26	84.4	24.7	7.15	56.6	16.6	6.03	36.9	10.8	4.97	18.6	5.5	3.89
3000	1415	112.8	33.1	7.66	86.0	25.2	6.55	58.2	17.1	5.43	38.5	11.3	4.37	20.2	5.9	3.29
3600	1700	114.4	33.5	7.36	87.6	25.7	6.25	59.8	17.5	5.13	40.1	11.8	4.07	21.8	6.4	2.99

7.5 TON STANDARD EFFICIENCY - THA090S - HEATING PERFORMANCE at 3000 cfm (1415 L/s) Indoor Coil Air Volume

*Outdoor Temperature		Compressor Motor kW Input	Total Output	
°F	°C		kBtuh	kW
65	18	7.66	112.8	33.1
60	16	7.39	106.5	31.2
55	13	7.11	100.1	29.3
50	10	6.84	93.8	27.5
47	8	6.67	90.0	26.4
45	7	6.55	86.0	25.2
40	4	6.25	76.0	22.3
35	2	5.94	66.0	19.3
30	-1	5.69	62.1	18.2
25	-4	5.43	58.2	17.1
20	-7	5.18	54.3	15.9
17	-8	5.02	52.0	15.2
15	-9	4.91	49.5	14.5
10	-12	4.64	43.1	12.6
5	-15	4.37	38.5	11.3
0	-18	4.10	34.0	10.0
-5	-21	3.83	29.4	8.6
-10	-23	3.56	24.8	7.3
-15	-26	3.29	20.2	5.9
-20	-29	3.01	15.6	4.6

*Outdoor temperature 70% relative humidity. Indoor temperature 70°F (21°C).

COOLING & HEATING RATINGS

8.5 TON

NOTE - For Temperatures and Capacities not shown in tables, see bulletin - Cooling Unit Rating Table Correction Factor Data in Miscellaneous Engineering Data section.

8.5 TON STANDARD EFFICIENCY - COOLING CAPACITY - ONE COMPRESSOR OPERATING

THA102S

Entering Wet Bulb Temperature	Total Air Volume		Outdoor Air Temperature Entering Outdoor Coil																							
			65°F (18°C)						75°F (24°C)						85°F (29°C)						95°F (35°C)					
			Total Cooling Capacity		Comp Motor kW Input	Sensible To Total Ratio (S/T) Dry Bulb			Total Cooling Capacity		Comp Motor kW Input	Sensible To Total Ratio (S/T) Dry Bulb			Total Cooling Capacity		Comp Motor kW Input	Sensible To Total Ratio (S/T) Dry Bulb			Total Cooling Capacity		Comp Motor kW Input	Sensible To Total Ratio (S/T) Dry Bulb		
			kBtuh	kW		75°F 24°C	80°F 27°C	85°F 29°C	kBtuh	kW		75°F 24°C	80°F 27°C	85°F 29°C	kBtuh	kW		75°F 24°C	80°F 27°C	85°F 29°C	kBtuh	kW		75°F 24°C	80°F 27°C	85°F 29°C
63°F (17°C)	2720	1285	51.6	15.1	2.76	.65	.80	.95	50.0	14.7	3.11	.65	.81	.97	48.4	14.2	3.51	.66	.83	.98	46.6	13.7	3.96	.67	.85	1.00
	3400	1605	53.5	15.7	2.78	.70	.88	1.00	51.9	15.2	3.14	.71	.90	1.00	50.2	14.7	3.53	.72	.92	1.00	48.4	14.2	3.98	.74	.94	1.00
	4080	1925	55.1	16.1	2.80	.76	.96	1.00	53.4	15.6	3.16	.77	.97	1.00	51.7	15.2	3.55	.79	.99	1.00	50.0	14.7	4.01	.74	1.00	1.00
67°F (19°C)	2720	1285	54.8	16.1	2.80	.51	.62	.76	53.1	15.6	3.15	.51	.63	.77	51.3	15.0	3.55	.52	.64	.79	49.4	14.5	4.01	.52	.65	.81
	3400	1605	56.5	16.6	2.82	.53	.67	.84	54.7	16.0	3.18	.54	.68	.86	52.8	15.5	3.58	.55	.70	.88	50.8	14.9	4.03	.55	.72	.91
	4080	1925	57.7	16.9	2.84	.56	.73	.92	55.8	16.4	3.19	.57	.75	.94	53.9	15.8	3.59	.58	.77	.96	51.9	15.2	4.04	.59	.78	.98
71°F (22°C)	2720	1285	58.3	17.1	2.84	.38	.49	.60	56.5	16.6	3.20	.38	.50	.61	54.6	16.0	3.60	.39	.50	.62	52.6	15.4	4.06	.39	.51	.63
	3400	1605	60.0	17.6	2.87	.39	.52	.65	58.1	17.0	3.23	.39	.53	.66	56.1	16.4	3.63	.40	.53	.67	54.0	15.8	4.08	.40	.54	.69
	4080	1925	61.2	17.9	2.89	.40	.55	.70	59.2	17.3	3.24	.41	.56	.72	57.1	16.7	3.64	.41	.57	.74	54.9	16.1	4.10	.41	.58	.76

8.5 TON STANDARD EFFICIENCY - COOLING CAPACITY - ALL COMPRESSORS OPERATING

THA102S

Entering Wet Bulb Temperature	Total Air Volume		Outdoor Air Temperature Entering Outdoor Coil																							
			85°F (29°C)						95°F (35°C)						105°F (41°C)						115°F (46°C)					
			Total Cooling Capacity		Comp Motor kW Input	Sensible To Total Ratio (S/T) Dry Bulb			Total Cooling Capacity		Comp Motor kW Input	Sensible To Total Ratio (S/T) Dry Bulb			Total Cooling Capacity		Comp Motor kW Input	Sensible To Total Ratio (S/T) Dry Bulb			Total Cooling Capacity		Comp Motor kW Input	Sensible To Total Ratio (S/T) Dry Bulb		
			kBtuh	kW		75°F 24°C	80°F 27°C	85°F 29°C	kBtuh	kW		75°F 24°C	80°F 27°C	85°F 29°C	kBtuh	kW		75°F 24°C	80°F 27°C	85°F 29°C	kBtuh	kW		75°F 24°C	80°F 27°C	85°F 29°C
63°F (17°C)	2720	1285	98.6	28.9	6.95	.69	.84	.98	95.0	27.8	7.84	.70	.86	.99	91.3	26.8	8.87	.71	.88	1.00	87.2	25.6	10.06	.73	.90	1.00
	3500	1650	102.6	30.1	7.00	.75	.93	1.00	99.0	29.0	7.90	.77	.95	1.00	95.1	27.9	8.94	.79	.97	1.00	91.2	26.7	10.11	.81	.99	1.00
	4280	2020	106.2	31.1	7.05	.82	.99	1.00	102.6	30.1	7.96	.84	1.00	1.00	98.8	29.0	8.99	.86	1.00	1.00	94.8	27.8	10.18	.88	1.00	1.00
67°F (19°C)	2720	1285	104.5	30.6	7.03	.54	.67	.80	100.7	29.5	7.94	.55	.68	.82	96.6	28.3	8.96	.55	.69	.84	92.3	27.1	10.15	.56	.71	.87
	3500	1650	108.0	31.7	7.09	.58	.73	.90	104.0	30.5	7.99	.58	.74	.92	99.7	29.2	9.00	.59	.76	.94	95.1	27.9	10.19	.61	.78	.96
	4280	2020	110.5	32.4	7.12	.61	.80	.97	106.3	31.2	8.02	.62	.82	.99	101.9	29.9	9.05	.63	.84	1.00	97.2	28.5	10.24	.65	.86	1.00
71°F (22°C)	2720	1285	111.3	32.6	7.13	.41	.53	.65	107.2	31.4	8.04	.41	.53	.66	102.9	30.2	9.07	.41	.54	.67	98.3	28.8	10.24	.41	.55	.68
	3500	1650	114.6	33.6	7.19	.42	.56	.71	110.3	32.3	8.09	.42	.57	.72	105.8	31.0	9.12	.43	.58	.74	101.0	29.6	10.30	.43	.60	.76
	4280	2020	116.9	34.3	7.22	.43	.60	.77	112.5	33.0	8.12	.44	.61	.79	107.7	31.6	9.16	.44	.63	.82	102.7	30.1	10.32	.45	.64	.84

8.5 TON STANDARD EFFICIENCY - HEATING CAPACITY

THA102S

Indoor Coil Air Volume 70°F db (21°C db)	Total Air Volume		Air Temperature Entering Outdoor Coil														
			65°F (18°C)			45°F (7°C)			25°F (-4°C)			5°F (-15°C)			-15°F (-26°C)		
			Total Heating Capacity		Comp. Motor kW Input	Total Heating Capacity		Comp. Motor kW Input	Total Heating Capacity		Comp. Motor kW Input	Total Heating Capacity		Comp. Motor kW Input	Total Heating Capacity		Comp. Motor kW Input
kBtuh	kW	kBtuh	kW	kBtuh		kW	kBtuh		kW	kBtuh		kW	kBtuh		kW		
2720	1285	128.5	37.7	6.85	95.3	27.9	5.54	61.0	17.9	4.17	37.1	10.9	3.27	19.1	5.6	2.10	
3400	1605	130.2	38.2	8.30	97.0	28.4	6.99	62.7	18.4	5.62	38.8	11.4	4.72	20.8	6.1	3.55	
4080	1925	133.0	39.0	9.74	99.8	29.2	8.43	65.5	19.2	7.06	41.6	12.2	6.16	23.6	6.9	4.99	

8.5 TON STANDARD EFFICIENCY - THA102S - HEATING PERFORMANCE at 3400 cfm (1605 L/s) Indoor Coil Air Volume

*Outdoor Temperature		Compressor Motor kW Input	Total Output	
°F	°C		kBtuh	kW
65	18	8.30	130.2	38.2
60	16	8.00	122.3	35.8
55	13	7.70	114.4	33.5
50	10	7.40	106.5	31.2
47	8	7.22	101.8	29.8
45	7	6.99	97.0	28.4
40	4	6.42	85.0	24.9
35	2	5.85	73.0	21.4
30	-1	5.74	67.8	19.9
25	-4	5.62	62.7	18.4
20	-7	5.50	57.5	16.9
17	-8	5.43	54.4	15.9
15	-9	5.31	51.2	15.0
10	-12	5.01	43.3	12.7
5	-15	4.72	38.8	11.4
0	-18	4.43	34.3	10.1
-5	-21	4.14	29.8	8.7
-10	-23	3.85	25.3	7.4
-15	-26	3.55	20.8	6.1
-20	-29	3.26	16.3	4.8

*Outdoor temperature 70% relative humidity. Indoor temperature 70°F(21°C).

COOLING & HEATING RATINGS

10 TON

NOTE - For Temperatures and Capacities not shown in tables, see bulletin - Cooling Unit Rating Table Correction Factor Data in Miscellaneous Engineering Data section.

10 TON STANDARD EFFICIENCY - COOLING CAPACITY - ONE COMPRESSOR OPERATING

THA120S

Entering Wet Bulb Temperature	Total Air Volume		Outdoor Air Temperature Entering Outdoor Coil																							
			65°F (18°C)						75°F (24°C)						85°F (29°C)						95°F (35°C)					
			Total Cooling Capacity		Comp Motor kW Input	Sensible To Total Ratio (S/T) Dry Bulb			Total Cooling Capacity		Comp Motor kW Input	Sensible To Total Ratio (S/T) Dry Bulb			Total Cooling Capacity		Comp Motor kW Input	Sensible To Total Ratio (S/T) Dry Bulb			Total Cooling Capacity		Comp Motor kW Input	Sensible To Total Ratio (S/T) Dry Bulb		
			kBtuh	kW		75°F 24°C	80°F 27°C	85°F 29°C	kBtuh	kW		75°F 24°C	80°F 27°C	85°F 29°C	kBtuh	kW		75°F 24°C	80°F 27°C	85°F 29°C	kBtuh	kW		75°F 24°C	80°F 27°C	85°F 29°C
63°F (17°C)	3200	1510	63.4	18.6	3.17	.66	.81	.96	61.6	18.1	3.56	.67	.83	.97	59.6	17.5	4.02	.68	.84	.99	57.5	16.9	4.54	.69	.86	1.00
	4000	1890	66.0	19.3	3.19	.72	.90	1.00	64.0	18.8	3.58	.73	.91	1.00	62.0	18.2	4.04	.74	.93	1.00	59.8	17.5	4.56	.76	.95	1.00
	4800	2265	68.1	20.0	3.21	.78	.97	1.00	66.1	19.4	3.60	.79	.98	1.00	64.1	18.8	4.06	.81	.99	1.00	61.9	18.1	4.59	.78	1.00	1.00
67°F (19°C)	3200	1510	67.4	19.8	3.20	.52	.64	.77	65.4	19.2	3.60	.53	.65	.79	63.3	18.6	4.06	.53	.66	.80	61.0	17.9	4.58	.54	.67	.82
	4000	1890	69.6	20.4	3.23	.55	.69	.86	67.5	19.8	3.62	.56	.70	.88	65.3	19.1	4.07	.56	.72	.90	62.9	18.4	4.60	.57	.73	.92
	4800	2265	71.2	20.9	3.24	.58	.75	.94	69.1	20.3	3.63	.59	.77	.96	66.7	19.5	4.09	.60	.79	.97	64.2	18.8	4.62	.61	.81	.99
71°F (22°C)	3200	1510	71.9	21.1	3.25	.39	.51	.62	69.8	20.5	3.64	.39	.51	.63	67.5	19.8	4.10	.40	.52	.64	65.0	19.0	4.63	.40	.52	.65
	4000	1890	74.1	21.7	3.27	.40	.54	.67	71.8	21.0	3.67	.41	.54	.68	69.4	20.3	4.12	.41	.55	.69	66.8	19.6	4.65	.41	.56	.71
	4800	2265	75.6	22.2	3.29	.41	.57	.73	73.2	21.5	3.68	.42	.58	.74	70.7	20.7	4.14	.42	.59	.76	68.0	19.9	4.67	.43	.60	.78

10 TON STANDARD EFFICIENCY - COOLING CAPACITY - ALL COMPRESSORS OPERATING

THA120S

Entering Wet Bulb Temperature	Total Air Volume		Outdoor Air Temperature Entering Outdoor Coil																							
			85°F (29°C)						95°F (35°C)						105°F (41°C)						115°F (46°C)					
			Total Cooling Capacity		Comp Motor kW Input	Sensible To Total Ratio (S/T) Dry Bulb			Total Cooling Capacity		Comp Motor kW Input	Sensible To Total Ratio (S/T) Dry Bulb			Total Cooling Capacity		Comp Motor kW Input	Sensible To Total Ratio (S/T) Dry Bulb			Total Cooling Capacity		Comp Motor kW Input	Sensible To Total Ratio (S/T) Dry Bulb		
			kBtuh	kW		75°F 24°C	80°F 27°C	85°F 29°C	kBtuh	kW		75°F 24°C	80°F 27°C	85°F 29°C	kBtuh	kW		75°F 24°C	80°F 27°C	85°F 29°C	kBtuh	kW		75°F 24°C	80°F 27°C	85°F 29°C
63°F (17°C)	3200	1510	117.4	34.4	7.94	.70	.85	.98	113.2	33.2	8.98	.71	.86	.99	108.7	31.9	10.15	.72	.88	1.00	104.0	30.5	11.50	.73	.91	1.00
	4000	1890	122.1	35.8	7.99	.75	.93	1.00	117.7	34.5	9.02	.77	.95	1.00	113.1	33.1	10.21	.78	.97	1.00	108.4	31.8	11.56	.81	.99	1.00
	4800	2265	126.1	37.0	8.03	.81	.99	1.00	121.8	35.7	9.07	.83	1.00	1.00	117.4	34.4	10.27	.85	1.00	1.00	112.8	33.1	11.62	.88	1.00	1.00
67°F (19°C)	3200	1510	124.7	36.5	8.02	.55	.67	.81	120.2	35.2	9.06	.55	.68	.82	115.3	33.8	10.25	.56	.70	.84	110.3	32.3	11.59	.57	.71	.87
	4000	1890	128.7	37.7	8.06	.58	.73	.89	124.0	36.3	9.10	.58	.74	.91	118.8	34.8	10.29	.59	.76	.94	113.5	33.3	11.66	.61	.78	.96
	4800	2265	131.5	38.5	8.09	.61	.79	.96	126.6	37.1	9.14	.62	.81	.98	121.4	35.6	10.33	.63	.83	.99	115.9	34.0	11.69	.64	.85	1.00
71°F (22°C)	3200	1510	133.0	39.0	8.11	.41	.53	.65	128.1	37.5	9.16	.41	.54	.66	122.9	36.0	10.34	.41	.54	.67	117.6	34.5	11.70	.42	.55	.69
	4000	1890	136.8	40.1	8.16	.42	.56	.71	131.7	38.6	9.21	.42	.57	.72	126.3	37.0	10.40	.43	.58	.74	120.6	35.3	11.75	.43	.59	.76
	4800	2265	139.4	40.9	8.19	.43	.60	.77	134.1	39.3	9.24	.44	.61	.79	128.5	37.7	10.44	.44	.62	.81	122.7	36.0	11.78	.45	.64	.83

10 TON STANDARD EFFICIENCY - HEATING CAPACITY

THA120S

Indoor Coil Air Volume 70°F db (21°C db)	Air Temperature Entering Outdoor Coil															
	65°F (18°C)			45°F (7°C)			25°F (-4°C)			5°F (-15°C)			-15°F (-26°C)			
	cfm	L/s	Total Heating Capacity kBtuh	kW	Comp. Motor kW Input	Total Heating Capacity kBtuh	kW	Comp. Motor kW Input	Total Heating Capacity kBtuh	kW	Comp. Motor kW Input	Total Heating Capacity kBtuh	kW	Comp. Motor kW Input	Total Heating Capacity kBtuh	kW
3200	1510	145.7	42.7	10.23	112.2	32.9	9.17	77.2	22.6	8.12	53.0	15.5	6.87	26.7	7.8	5.29
4000	1890	147.2	43.1	9.45	113.7	33.3	8.39	78.7	23.1	7.34	54.5	16.0	6.09	28.2	8.3	4.51
4800	2265	150.7	44.2	9.03	117.2	34.3	7.97	82.2	24.1	6.92	58.0	17.0	5.67	31.7	9.3	4.09

10 TON STANDARD EFFICIENCY - THA120S - HEATING PERFORMANCE at 4000 cfm (1890 L/s) Indoor Coil Air Volume

*Outdoor Temperature		Compressor Motor kW Input	Total Output	
°F	°C		kBtuh	kW
65	18	9.45	147.2	43.1
60	16	9.18	139.4	40.9
55	13	8.91	131.5	38.5
50	10	8.64	123.7	36.3
47	8	8.48	119.0	34.9
45	7	8.39	113.7	33.3
40	4	8.16	100.3	29.4
35	2	7.93	87.0	25.5
30	-1	7.64	82.8	24.3
25	-4	7.34	78.7	23.1
20	-7	7.04	74.5	21.8
17	-8	6.86	72.0	21.1
15	-9	6.75	68.9	20.2
10	-12	6.48	61.0	17.9
5	-15	6.09	54.5	16.0
0	-18	5.70	47.9	14.0
-5	-21	5.30	41.3	12.1
-10	-23	4.91	34.7	10.2
-15	-26	4.51	28.2	8.3
-20	-29	4.12	21.6	6.3

*Outdoor temperature 70% relative humidity. Indoor temperature 70°F (21°C).

COOLING & HEATING RATINGS

12.5 TON

NOTE - For Temperatures and Capacities not shown in tables, see bulletin - Cooling Unit Rating Table Correction Factor Data in Miscellaneous Engineering Data section.

12.5 TON STANDARD EFFICIENCY - COOLING CAPACITY - ONE COMPRESSOR OPERATING

THA150S

Entering Wet Bulb Temperature	Total Air Volume		Outdoor Air Temperature Entering Outdoor Coil																							
			65°F (18°C)						75°F (24°C)						85°F (29°C)						95°F (35°C)					
			Total Cooling Capacity		Comp Motor kW Input	Sensible To Total Ratio (S/T) Dry Bulb			Total Cooling Capacity		Comp Motor kW Input	Sensible To Total Ratio (S/T) Dry Bulb			Total Cooling Capacity		Comp Motor kW Input	Sensible To Total Ratio (S/T) Dry Bulb			Total Cooling Capacity		Comp Motor kW Input	Sensible To Total Ratio (S/T) Dry Bulb		
			kBtuh	kW		75°F 24°C	80°F 27°C	85°F 29°C	kBtuh	kW		75°F 24°C	80°F 27°C	85°F 29°C	kBtuh	kW		75°F 24°C	80°F 27°C	85°F 29°C	kBtuh	kW		75°F 24°C	80°F 27°C	85°F 29°C
63°F (17°C)	3800	1795	69.4	20.3	4.97	.61	.77	.93	67.2	19.7	5.59	.61	.79	.95	65.0	19.0	6.26	.62	.80	.97	62.7	18.4	6.99	.63	.82	.99
	4400	2075	71.1	20.8	5.01	.64	.83	.99	68.9	20.2	5.63	.65	.85	1.00	66.6	19.5	6.30	.67	.87	1.00	64.3	18.8	7.03	.68	.89	1.00
	5000	2360	72.6	21.3	5.04	.68	.89	1.00	70.4	20.6	5.67	.69	.90	1.00	68.1	20.0	6.33	.71	.93	1.00	65.7	19.3	7.07	.73	.95	1.00
67°F (19°C)	3800	1795	73.6	21.6	5.05	.48	.58	.72	71.3	20.9	5.68	.48	.59	.74	68.9	20.2	6.36	.48	.60	.76	66.4	19.5	7.10	.49	.61	.78
	4400	2075	75.2	22.0	5.08	.49	.61	.78	72.7	21.3	5.71	.50	.62	.80	70.3	20.6	6.39	.50	.64	.83	67.7	19.8	7.14	.51	.65	.85
	5000	2360	76.4	22.4	5.10	.51	.65	.84	73.9	21.7	5.74	.51	.67	.86	71.4	20.9	6.43	.52	.68	.89	68.7	20.1	7.17	.53	.70	.91
71°F (22°C)	3800	1795	78.3	22.9	5.14	.36	.46	.56	75.8	22.2	5.78	.36	.47	.57	73.3	21.5	6.47	.36	.47	.58	70.6	20.7	7.22	.36	.48	.59
	4400	2075	79.9	23.4	5.17	.36	.48	.59	77.2	22.6	5.81	.37	.48	.60	74.6	21.9	6.51	.37	.49	.61	71.8	21.0	7.27	.37	.50	.62
	5000	2360	81.0	23.7	5.19	.37	.50	.62	78.4	23.0	5.84	.37	.50	.64	75.6	22.2	6.54	.38	.51	.65	72.8	21.3	7.30	.38	.52	.67

12.5 TON STANDARD EFFICIENCY - COOLING CAPACITY - ALL COMPRESSORS OPERATING

THA150S

Entering Wet Bulb Temperature	Total Air Volume		Outdoor Air Temperature Entering Outdoor Coil																							
			85°F (29°C)						95°F (35°C)						105°F (41°C)						115°F (46°C)					
			Total Cooling Capacity		Comp Motor kW Input	Sensible To Total Ratio (S/T) Dry Bulb			Total Cooling Capacity		Comp Motor kW Input	Sensible To Total Ratio (S/T) Dry Bulb			Total Cooling Capacity		Comp Motor kW Input	Sensible To Total Ratio (S/T) Dry Bulb			Total Cooling Capacity		Comp Motor kW Input	Sensible To Total Ratio (S/T) Dry Bulb		
			kBtuh	kW		75°F 24°C	80°F 27°C	85°F 29°C	kBtuh	kW		75°F 24°C	80°F 27°C	85°F 29°C	kBtuh	kW		75°F 24°C	80°F 27°C	85°F 29°C	kBtuh	kW		75°F 24°C	80°F 27°C	85°F 29°C
63°F (17°C)	3800	1795	139.1	40.8	10.24	.66	.81	.96	134.4	39.4	11.44	.67	.83	.98	129.3	37.9	12.79	.68	.85	.99	123.7	36.3	14.34	.69	.87	1.00
	4400	2075	142.7	41.8	10.30	.69	.87	1.00	137.8	40.4	11.51	.70	.89	1.00	132.5	38.8	12.87	.72	.91	1.00	126.7	37.1	14.42	.74	.94	1.00
	5000	2360	145.6	42.7	10.37	.73	.92	1.00	140.7	41.2	11.57	.75	.94	1.00	135.3	39.7	12.94	.76	.96	1.00	129.7	38.0	14.49	.79	.98	1.00
67°F (19°C)	3800	1795	147.5	43.2	10.40	.52	.63	.77	142.3	41.7	11.61	.52	.64	.79	136.7	40.1	12.98	.53	.65	.81	130.8	38.3	14.53	.53	.67	.83
	4400	2075	150.5	44.1	10.46	.53	.67	.83	145.2	42.6	11.68	.54	.68	.85	139.4	40.9	13.05	.55	.69	.87	133.3	39.1	14.61	.56	.71	.90
	5000	2360	152.9	44.8	10.51	.55	.70	.88	147.5	43.2	11.73	.56	.72	.91	141.6	41.5	13.11	.57	.74	.93	135.4	39.7	14.66	.58	.76	.95
71°F (22°C)	3800	1795	157.0	46.0	10.58	.39	.50	.61	151.4	44.4	11.81	.39	.51	.62	145.4	42.6	13.20	.39	.51	.63	139.1	40.8	14.77	.39	.52	.65
	4400	2075	159.9	46.9	10.64	.39	.52	.64	154.1	45.2	11.89	.40	.53	.66	148.1	43.4	13.28	.40	.53	.67	141.4	41.4	14.84	.40	.54	.69
	5000	2360	162.2	47.5	10.69	.40	.54	.68	156.4	45.8	11.93	.40	.55	.69	150.1	44.0	13.32	.41	.56	.71	143.2	42.0	14.90	.41	.57	.74

12.5 TON STANDARD EFFICIENCY - HEATING CAPACITY

THA150S

Indoor Coil Air Volume 70°F db (21°C db)	Total Air Volume		Air Temperature Entering Outdoor Coil														
			65°F (18°C)			45°F (7°C)			25°F (-4°C)			5°F (-15°C)			-15°F (-26°C)		
			Total Heating Capacity		Comp. Motor kW Input	Total Heating Capacity		Comp. Motor kW Input	Total Heating Capacity		Comp. Motor kW Input	Total Heating Capacity		Comp. Motor kW Input	Total Heating Capacity		Comp. Motor kW Input
kBtuh	kW	kBtuh	kW	kBtuh		kW	kBtuh		kW	kBtuh		kW	kBtuh		kW		
3800	1795	167.6	49.1	10.89	127.3	37.3	10.10	85.1	24.9	9.29	57.8	16.9	8.27	29.2	8.6	6.16	
4400	2075	169.6	49.7	10.39	129.3	37.9	9.60	87.1	25.5	8.79	59.8	17.5	7.77	31.2	9.1	5.66	
5000	2360	172.8	50.6	9.97	132.5	38.8	9.18	90.3	26.5	8.37	63.0	18.5	7.35	34.4	10.1	5.24	

12.5 TON STANDARD EFFICIENCY - THA150S - HEATING PERFORMANCE at 4400 cfm (2075 L/s) Indoor Coil Air Volume

*Outdoor Temperature		Compressor Motor kW Input	Total Output	
°F	°C		kBtuh	kW
65	18	10.39	169.6	49.7
60	16	10.20	160.3	47.0
55	13	10.01	150.9	44.2
50	10	9.82	141.6	41.5
47	8	9.70	136.0	39.9
45	7	9.60	129.3	37.9
40	4	9.34	112.7	33.0
35	2	9.07	96.0	28.1
30	-1	8.93	91.6	26.8
25	-4	8.79	87.1	25.5
20	-7	8.65	82.7	24.2
17	-8	8.56	80.0	23.4
15	-9	8.49	76.3	22.4
10	-12	8.30	66.9	19.6
5	-15	7.77	59.8	17.5
0	-18	7.24	52.6	15.4
-5	-21	6.72	45.5	13.3
-10	-23	6.19	38.3	11.2
-15	-26	5.66	31.2	9.1
-20	-29	5.14	24.0	7.0

*Outdoor temperature 70% relative humidity. Indoor temperature 70°F(21°C).

BLOWER DATA

BELT DRIVE BLOWER - BASE UNIT

BLOWER TABLE INCLUDES RESISTANCE FOR BASE UNIT ONLY (NO HEAT SECTION) WITH DRY INDOOR COIL AND AIR FILTERS IN PLACE. FOR ALL UNITS ADD:

- 1 - Wet indoor coil air resistance of selected unit.
- 2 - Any factory installed options air resistance (heat section, economizer, etc.)
- 3 - Any field installed accessories air resistance (duct resistance, diffuser, etc.)

Then determine from blower table blower motor output and drive required.

See below for blower motors and drives. See page NO TAG for wet coil and option/accessory air resistance data.

MINIMUM AIR VOLUME REQUIRED FOR USE WITH OPTIONAL ELECTRIC HEAT

3000 cfm (1415 L/s) minimum air with electric heat for THA090/102 models.

4000 cfm (1890 L/s) minimum air with electric heat for THA120/150 models.

BOLD INDICATES FIELD FURNISHED DRIVE.

Air Volume cfm (L/s)	Total Static Pressure - in. w.g. (Pa)																													
	.20 (50)		.40 (100)		.60 (150)		.80 (200)		1.00 (250)		1.20 (300)		1.40 (350)		1.60 (400)		1.80 (450)		2.00 (495)		2.20 (545)		2.40 (595)		2.60 (645)					
	RPM	BHP (kW)	RPM	BHP (kW)	RPM	BHP (kW)	RPM	BHP (kW)	RPM	BHP (kW)	RPM	BHP (kW)	RPM	BHP (kW)	RPM	BHP (kW)	RPM	BHP (kW)	RPM	BHP (kW)	RPM	BHP (kW)	RPM	BHP (kW)	RPM	BHP (kW)	RPM	BHP (kW)	RPM	BHP (kW)
2250 (1060)	455	0.30	555	0.45	640	0.60	720	0.80	790	1.00	855	1.20	915	1.40	975	1.60	1030	1.85	1080	2.05	1130	2.30	1175	2.55	1220	2.80				
2500 (1180)	475	0.40	575	0.55	660	0.70	735	0.90	805	1.10	870	1.30	930	1.55	985	1.75	1040	2.00	1090	2.25	1140	2.50	1185	2.75	1230	3.00				
2750 (1300)	495	0.45	595	0.65	675	0.85	750	1.05	820	1.25	885	1.45	940	1.70	995	1.90	1050	2.20	1100	2.45	1145	2.65	1195	2.95	1240	3.25				
3000 (1415)	525	0.55	615	0.75	695	0.95	770	1.20	835	1.40	895	1.60	955	1.85	1010	2.10	1060	2.35	1110	2.65	1160	2.90	1205	3.20	1250	3.45				
3250 (1535)	550	0.65	640	0.90	715	1.10	790	1.35	855	1.60	915	1.80	970	2.05	1025	2.35	1075	2.60	1125	2.85	1170	3.15	1215	3.40	1260	3.70				
3500 (1650)	580	0.80	665	1.05	740	1.25	810	1.50	870	1.75	930	2.00	985	2.25	1040	2.55	1090	2.85	1135	3.10	1185	3.40	1230	3.70	1270	4.00				
3750 (1770)	605	0.95	690	1.20	760	1.45	830	1.70	890	1.95	950	2.25	1005	2.50	1055	2.80	1105	3.10	1150	3.35	1195	3.65	1240	3.95	1285	4.30				
4000 (1890)	635	1.10	715	1.40	785	1.65	850	1.90	910	2.20	965	2.45	1020	2.75	1070	3.05	1120	3.35	1165	3.65	1210	3.95	1255	4.30	1295	4.60				
4250 (2005)	665	1.30	740	1.60	810	1.85	870	2.15	930	2.45	985	2.75	1040	3.05	1090	3.35	1135	3.65	1185	4.00	1225	4.30	1270	4.65	1310	4.95				
4500 (2125)	695	1.50	770	1.80	835	2.10	895	2.40	955	2.70	1005	3.00	1060	3.35	1105	3.65	1155	4.00	1200	4.30	1245	4.65	1285	5.00	1325	5.30				
4750 (2240)	725	1.75	795	2.05	860	2.40	920	2.70	975	3.00	1030	3.35	1080	3.65	1125	3.95	1175	4.35	1215	4.65	1260	5.00	1300	5.35	1340	5.70				
5000 (2360)	760	2.05	825	2.35	885	2.65	945	3.00	1000	3.35	1050	3.65	1100	4.00	1145	4.35	1190	4.70	1235	5.05	1280	5.45	---	---	---	---				
5250 (2475)	790	2.30	855	2.65	910	2.95	970	3.35	1020	3.65	1070	4.00	1120	4.35	1165	4.70	1210	5.10	1255	5.45	---	---	---	---						
5500 (2595)	820	2.60	880	2.95	940	3.30	995	3.70	1045	4.05	1095	4.40	1145	4.80	1190	5.15	1230	5.50	---	---	---	---	---	---						
5750 (2715)	850	2.95	910	3.30	965	3.70	1020	4.05	1070	4.45	1120	4.80	1165	5.20	1210	5.60	---	---	---	---	---	---	---	---						
6000 (2830)	885	3.35	940	3.70	995	4.10	1045	4.45	1095	4.85	1145	5.25	1190	5.65	---	---	---	---	---	---	---	---	---	---						

FACTORY INSTALLED DRIVE KIT SPECIFICATIONS

Motor Outputs		RPM Range				
Nominal hp	Maximum hp	Drive 1	Drive 3	Drive 4	Drive 5	Drive 6
2	2.3	680 - 925	895 - 1120	---	---	---
3	3.45	680 - 925	895 - 1120	---	1110 - 1395	---
5	5.75	---	---	895 - 1120	---	1110 - 1395

NOTE - Using total air volume and system static pressure requirements determine from blower performance tables rpm and motor output required. Maximum usable output of motors furnished by Lennox are shown. In Canada, nominal motor output is also maximum usable motor output. If motors of comparable output are used, be sure to keep within the service factor limitations outlined on the motor nameplate.

BLOWER DATA

OPTIONS / ACCESSORY AIR RESISTANCE - in. w.g.

Air Volume cfm	Wet Indoor Coil		Electric Heat	Economizer
	090/102	120/150		
2250	0.06	0.10	0.01	0.035
2500	0.08	0.12	0.01	0.04
2750	0.09	0.14	0.01	0.045
3000	0.10	0.16	0.02	0.05
3250	0.11	0.19	0.02	0.06
3500	0.13	0.21	0.03	0.07
3750	0.14	0.23	0.03	0.075
4000	0.16	0.26	0.04	0.08
4250	0.17	0.28	0.04	0.09
4500	0.18	0.31	0.05	0.10
4750	0.20	0.33	0.05	0.11
5000	0.22	0.36	0.06	0.12
5250	0.24	0.39	0.06	0.13
5500	0.26	0.42	0.07	0.14
5750	0.28	0.45	0.07	0.15
6000	0.30	0.48	0.08	0.16

AIR RESISTANCE - CEILING DIFFUSERS - in. w.g.

Unit Size	Air Volume - cfm	RTD11 Step-Down Diffuser			FD11 Flush Diffuser
		2 Ends Open	1 Side, 2 Ends Open	All Ends & Sides Open	
090 Models	2400	0.21	0.18	0.15	0.14
	2600	0.24	0.21	0.18	0.17
	2800	0.27	0.24	0.21	0.20
	3000	0.32	0.29	0.25	0.25
	3200	0.41	0.37	0.32	0.31
	3400	0.50	0.45	0.39	0.37
	3600	0.61	0.54	0.48	0.44
102 & 120 Models	3800	0.73	0.63	0.57	0.51
	3600	0.36	0.28	0.23	0.15
	3800	0.40	0.32	0.26	0.18
	4000	0.44	0.36	0.29	0.21
	4200	0.49	0.40	0.33	0.24
	4400	0.54	0.44	0.37	0.27
	4600	0.60	0.49	0.42	0.31
	4800	0.65	0.53	0.46	0.35
150 Models	5000	0.69	0.58	0.50	0.39
	5200	0.75	0.62	0.54	0.43
	4200	0.22	0.19	0.16	0.10
	4400	0.28	0.24	0.20	0.12
	4600	0.34	0.29	0.24	0.15
	4800	0.40	0.34	0.29	0.19
	5000	0.46	0.39	0.34	0.23
	5200	0.52	0.44	0.39	0.27
150 Models	5400	0.58	0.49	0.43	0.31
	5600	0.64	0.54	0.47	0.35
	5800	0.70	0.59	0.51	0.39

BLOWER DATA

CEILING DIFFUSER AIR THROW DATA - ft.

Model No.	Air Volume cfm	¹ Effective Throw Range	
		RTD11 Step-Down	FD11 Flush
090	2600	24 - 29	19 - 24
	2800	25 - 30	20 - 28
	3000	27 - 33	21 - 29
	3200	28 - 35	22 - 29
	3400	30 - 37	22 - 30
102 120	3600	25 - 33	22 - 29
	3800	27 - 35	22 - 30
	4000	29 - 37	24 - 33
	4200	32 - 40	26 - 35
	4400	34 - 42	28 - 37
150	5600	39 - 49	28 - 37
	5800	42 - 51	29 - 38
	6000	44 - 54	40 - 50
	6200	45 - 55	42 - 51
	6400	46 - 55	43 - 52
	6600	47 - 56	45 - 56

POWER EXHAUST FANS PERFORMANCE

Return Air System Static Pressure - in. w.g.	Air Volume Exhausted - cfm
0	4200
0.05	3970
0.10	3750
0.15	3520
0.20	3300
0.25	3080
0.30	2860
0.35	2640

¹ Throw is the horizontal or vertical distance an air stream travels on leaving the outlet or diffuser before the maximum velocity is reduced to 50 ft. per minute. Four sides open.

ELECTRICAL/ELECTRIC HEAT DATA

7.5 TON HIGH EFFICIENCY (R-22)

THA090S

Voltage - 60hz - 3 phase		208/230V-3ph		460V-3ph		575V-3ph		
Compressors (2)	Rated Load Amps (total)	12.4 (24.9)		6.4 (12.8)		4.8 (9.6)		
	Locked Rotor Amps (total)	88 (176)		44 (88)		34 (68)		
Outdoor Fan Motors (2)	Full Load Amps (total)	2.4 (4.8)		1.3 (2.6)		1.0 (2.0)		
	Locked Rotor Amps (total)	4.7 (9.4)		2.4 (4.8)		1.9 (3.8)		
Optional Power Exhaust Fan	(Number) Horsepower	(1) 1/3		(1) 1/3		(1) 1/3		
	Full load amps	2.4		1.3		1.0		
	Locked rotor amps	4.7		2.4		1.9		
Service Outlet (2) 115 volt GFCI (amp rating)		15		15		15		
Indoor Blower Motor	Horsepower	2	3	2	3	2	3	
	Rated Load Amps	7.5	10.6	3.4	4.8	2.7	3.9	
	Locked Rotor Amps	46.9	66	20.4	26.8	16.2	23.4	
¹ Minimum Circuit Ampacity	Unit Only	41	44	21	22	16	17	
	with power exhaust	0 kW	43	46	22	24	17	18
		7.5 kW	66	69	33	35	26	27
		15 kW	88	91	45	46	35	36
		22.5 kW	111	114	56	57	44	45
		30 kW	133	136	67	69	53	54
		45 kW	178	182	90	71	71	72
² Maximum Overcurrent Protection	Unit Only	50	50	25	25	20	20	
	with power exhaust	0 kW	50	50	25	25	20	20
		7.5 kW	70	70	35	35	30	30
		15 kW	90	100	45	50	35	40
		22.5 kW	125	125	60	60	45	45
		30 kW	150	150	70	70	60	60
		45 kW	200	200	100	100	80	80
Unit Fuse Block	Unit Only	56K93	56K93	56K52	56K52	56K51	56K51	
	with power exhaust	56K93	56K93	56K52	56K52	56K51	56K51	
Disconnect	0-15 kW	84M13	84M13	84M13	84M13	84M13	84M13	
	22.5 kW	84M13	84M13	84M13	84M13	84M13	84M13	
	30-45 kW	Factory	Factory	84M13	84M13	84M13	84M13	
Terminal Block		LTB2-175		LTB2-175		LTB2-175		

NOTE - Extremes of operating range are plus and minus 10% of line voltage.

¹ HACR type breaker or fuse.

² Refer to National or Canadian Electrical Code manual to determine wire, fuse and disconnect size requirements.

ELECTRICAL/ELECTRIC HEAT DATA

8.5 TON HIGH EFFICIENCY (R-22)

THA102S

Voltage - 60hz - 3 phase		208/230V-3ph		460V-3ph		575V-3ph		
Compressors (2)	Rated Load Amps (total)	14.7 (29.4)		7.1 (14.2)		5.1 (10.2)		
	Locked Rotor Amps (total)	91 (182)		50 (100)		37 (74)		
Outdoor Fan Motors (2)	Full Load Amps (total)	2.4 (4.8)		1.3 (2.6)		1.0 (2.0)		
	Locked Rotor Amps (total)	4.7 (9.4)		2.4 (4.8)		1.9 (3.8)		
Optional Power Exhaust Fan	(Number) Horsepower	(1) 1/3		(1) 1/3		(1) 1/3		
	Full load amps	2.4		1.3		1.0		
	Locked rotor amps	4.7		2.4		1.9		
Service Outlet (2) 115 volt GFCI (amp rating)		15		15		15		
Indoor Blower Motor	Horsepower	2	3	2	3	2	3	
	Rated Load Amps	7.5	10.6	3.4	4.8	2.7	3.9	
	Locked Rotor Amps	46.9	66	20.4	26.8	16.2	23.4	
¹ Maximum Overcurrent Protection	Unit Only	60	60	25	30	20	20	
	with power exhaust	0 kW	60	60	30	30	20	20
		7.5 kW	80	80	35	40	30	30
		15 kW	100	100	50	50	40	40
		22.5 kW	125	125	60	60	45	50
		30 kW	150	150	70	70	60	60
		45 kW	200	200	100	100	80	80
² Minimum Circuit Ampacity	Unit Only	46	49	22	24	17	18	
	with power exhaust	0 kW	48	51	24	25	18	19
		7.5 kW	71	74	35	36	27	28
		15 kW	93	96	46	48	36	37
		22.5 kW	116	119	58	59	45	46
		30 kW	138	4142	69	70	54	55
		45 kW	184	187	91	93	72	73
Unit Fuse Block	Unit Only	56K94	56K94	56K52	25K08	56K51	56K51	
	with power exhaust	56K94	56K94	25K08	25K08	56K51	56K52	
Disconnect	0-15 kW	84M13	84M13	84M13	84M13	84M13	84M13	
	22.5 kW	84M13	84M13	84M13	84M13	84M13	84M13	
	30-45 kW	Factory	Factory	84M13	84M13	84M13	84M13	
Terminal Block		LTB2-175		LTB2-175		LTB2-175		

NOTE - Extremes of operating range are plus and minus 10% of line voltage.

¹ HACR type breaker or fuse.

² Refer to National or Canadian Electrical Code manual to determine wire, fuse and disconnect size requirements.

ELECTRICAL/ELECTRIC HEAT DATA

10 TON HIGH EFFICIENCY (R-22)

THA120S

Voltage - 60hz - 3 phase		208/230V-3ph			460V-3ph			575V-3ph			
Compressors (2)	Rated Load Amps (total)	17.3 (34.6)			9.0 (18.0)			7.1 (14.2)			
	Locked Rotor Amps (total)	123 (246)			62 (124)			50 (100)			
Outdoor Fan Motors (2)	Full Load Amps (total)	2.4 (4.8)			1.3 (2.6)			1.0 (2.0)			
	Locked Rotor Amps (total)	4.7 (9.4)			2.4 (4.8)			1.9 (3.8)			
Optional Power Exhaust Fan	(Number) Horsepower	(1) 1/3			(1) 1/3			(1) 1/3			
	Full load amps	2.4			1.3			1.0			
	Locked rotor amps	4.7			2.4			1.9			
Service Outlet (2) 115 volt GFCI (amp rating)		15	15		15	15		15	15		
Indoor Blower Motor	Horsepower	2	3	5	2	3	5	2	3	5	
	Rated Load Amps	7.5	10.6	16.7	3.4	4.8	7.6	2.7	3.9	6.1	
	Locked Rotor Amps	46.9	66	105	20.4	26.88	45.6	16.2	23.4	36.6	
¹ Maximum Overcurrent Protection	Unit Only	60	70	70	35	35	35	25	25	30	
	with power exhaust	0 kW	70	70	80	35	35	40	25	25	30
		15 kW	100	110	110	60	60	60	40	45	45
		22.5 kW	125	125	150	70	70	70	50	50	60
		30 kW	150	150	175	80	80	80	60	60	70
		45 kW	200	200	200	100	100	100	80	80	80
		60 kW	200	225	225	100	110	110	80	90	90
² Minimum Circuit Ampacity	Unit Only	52	55	61	27	28	31	21	22	25	
	with power exhaust	0 kW	54	57	63	28	29	32	22	23	26
		15 kW	99	102	108	51	52	55	40	41	44
		22.5 kW	122	125	131	62	63	66	49	50	53
		30 kW	144	147	154	73	75	77	58	59	62
		45 kW	189	193	199	96	97	100	76	78	80
		60 kW	198	202	208	100	102	104	80	81	83
Unit Fuse Block	Unit Only	56K94	56K94	56K95	25K08	25K08	25K08	56K51	56K52	56K52	
	with power exhaust	56K94	56K94	56K95	25K08	25K08	25K09	56K51	56K52	56K52	
Disconnect	0 kW	84M13	84M13	84M13	84M13	84M13	84M13	84M13	84M13	84M13	
	15-22.5 kW	Factory	Factory	Factory	84M13	84M13	84M13	84M13	84M13	84M13	
	30 kW	Factory	Factory	N/A	84M13	84M13	84M13	84M13	84M13	84M13	
	45 kW	N/A	N/A	N/A	Factory	Factory	Factory	84M13	84M13	84M13	
	60 kW	N/A	N/A	N/A	Factory	Factory	Factory	Factory	Factory	Factory	
Terminal Block	15-45 kW	LTB2-175			LTB2-175			LTB2-175			
	60 kW	LTB2-335			LTB2-175			LTB2-175			

NOTE - Extremes of operating range are plus and minus 10% of line voltage.

¹ HACR type breaker or fuse.

² Refer to National or Canadian Electrical Code manual to determine wire, fuse and disconnect size requirements.

ELECTRICAL/ELECTRIC HEAT DATA

12.5 TON STANDARD EFFICIENCY (R-22)

THA150S2

Voltage - 60hz - 3 phase		208/230V-3ph		460V-3ph		575V-3ph		
Compressors (2)	Rated Load Amps (total)	19.3 (38.6)		9.0 (18.0)		7.4 (14.8)		
	Locked Rotor Amps (total)	156 (312)		75 (150)		54 (108)		
Outdoor Fan Motors (2)	Full Load Amps (total)	2.4 (4.8)		1.3 (2.6)		1.0 (2.0)		
	Locked Rotor Amps (total)	4.7 (9.4)		2.4 (4.8)		1.9 (3.8)		
Optional Power Exhaust Fan	(Number) Horsepower	(1) 1/3		(1) 1/3		(1) 1/3		
	Full load amps	2.4		1.3		1.0		
	Locked rotor amps	4.7		2.4		1.9		
Service Outlet (2) 115 volt GFCI (amp rating)		15		15		15		
Indoor Blower Motor	Horsepower	3	5	3	5	3	5	
	Rated Load Amps	10.6	16.7	4.8	7.6	3.9	6.1	
	Locked Rotor Amps	66	105	26.8	45.6	23.4	36.6	
¹ Maximum Overcurrent Protection	Unit Only	70	80	35	35	25	30	
	with power exhaust	0 kW	110	125	35	60	45	45
		15 kW	110	125	60	60	45	45
		22.5 kW	150	150	70	70	60	60
		30 kW	175	175	80	80	70	70
		45 kW	200	225	100	110	80	90
		60 kW	225	225	110	110	90	90
² Minimum Circuit Ampacity	Unit Only	59	65	28	31	23	25	
	with power exhaust	0 kW	109	115	31	56	43	45
		15 kW	109	115	54	56	43	45
		22.5 kW	131	137	65	68	52	54
		30 kW	154	160	76	79	61	63
		45 kW	199	205	99	101	79	81
		60 kW	208	214	103	106	83	85
Unit Fuse Block	Unit Only	56K95	56K96	25K09	25K09	56K52	25K08	
	with power exhaust	56K95	56K96	25K09	25K10	25K08	25K08	
Disconnect	0 kW	84M13	84M13	84M13	84M13	84M13	84M13	
	15-22.5 kW	Factory	Factory	84M13	84M13	84M13	84M13	
	30 kW	Factory	N/A	84M13	84M13	84M13	84M13	
	45 kW	N/A	N/A	Factory	Factory	84M13	84M13	
	60 kW	N/A	N/A	Factory	Factory	Factory	Factory	
Terminal Block	15-45 kW	LTB2-175		LTB2-175		LTB2-175		
	60 kW	LTB2-335		LTB2-175		LTB2-175		

NOTE - Extremes of operating range are plus and minus 10% of line voltage.

¹ HACR type breaker or fuse.

² Refer to National or Canadian Electrical Code manual to determine wire, fuse and disconnect size requirements.

UNIT CLEARANCES - INCHES (MM)

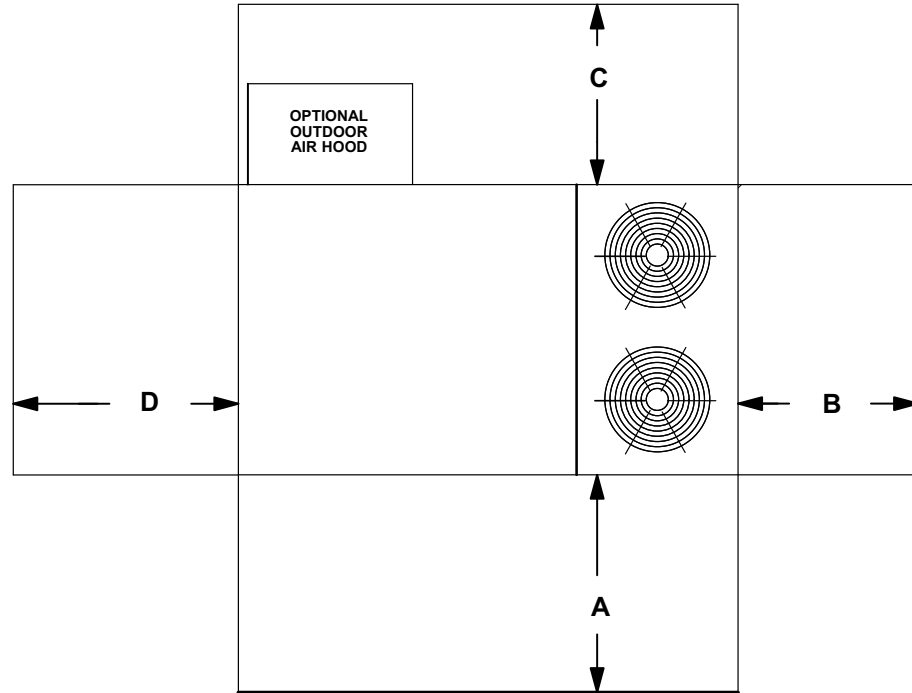

¹ Unit Clearance	A		B		C		D		Top Clearance
	in.	mm	in.	mm	in.	mm	in.	mm	
Service Clearance	60	1524	36	914	36	914	36	914	Unobstructed
Minimum Operation Clearance	36	914	36	914	36	914	36	914	

NOTE - Entire perimeter of unit base requires support when elevated above the mounting surface.

¹ **Service Clearance** - Required for removal of serviceable parts.

Minimum Operation Clearance - Required clearance for proper unit operation.

OUTDOOR SOUND DATA

Unit Model No.	Operating Mode	Octave Band Sound Power Levels dBA, re 10 ⁻¹² Watts							¹ Sound Rating Number (dB)
		Center Frequency - HZ							
		125	250	500	1000	2000	4000	8000	
THA090, THA102, THA120, and THA150	Cooling	70	75	80	80	76	71	64	88
	Heating	69	77	81	82	78	72	65	88

Note - The octave sound power data does not include tonal corrections.

¹ Tested according to ARI Standard 270-95 test conditions.

OPTIONAL CONVENTIONAL TEMPERATURE CONTROL SYSTEMS - FIELD INSTALLED

COMMERCIAL TOUCHSCREEN THERMOSTAT



Intuitive Touchscreen Interface - **Two Stage Heating / Two Stage Cooling Conventional or Heat Pump** - Seven Day Programmable - Four Time Periods/Day - Economizer Output - Title 24 Compliant - ENERGY STAR® Qualified - Backlit Display - Automatic Changeover

C0STAT02AE1L



Sensors For Touchscreen Thermostat

1 Remote non-adjustable wall mount 20k temperature sensor	C0SNZN01AE1-
1 Remote non-adjustable wall mount 10k averaging temperature sensor	C0SNZN73AE1-
1 Remote non-adjustable duct mount temperature sensor	C0SNDC00AE1-
Outdoor temperature sensor	C0SNSR03AE1-

Accessories For Touchscreen Thermostat

Locking cover (clear)	C0MISC15AE1-
-----------------------------	--------------

¹ Remote sensors for C0STAT02AE1L can be applied in the following combinations: (1) C0SNZN01AE1-, (2) C0SNZN73AE1-, (2) C0SNZN01AE1- and (1) C0SNZN73AE1-, (4) C0SNZN01AE1-, (3) C0SNZN01AE1- and (2) C0SNZN73AE1.

DIGITAL NON-PROGRAMMABLE THERMOSTATS



Intuitive Interface - Automatic Changeover - Simple Up and Down Temperature Control

Two-stage heating / cooling conventional systems	C0STAT10AE1L
---	--------------

Sensor For Digital Non-Programmable Thermostats Above

Remote wall mounted temperature sensor	C0SNZN00AE1-
--	--------------



Intuitive Interface - Automatic Changeover - Backlit Display - Simple Up and Down Temperature Control

One-stage heating / cooling conventional systems	C0STAT12AE1L
---	--------------

Sensor For Digital Non-Programmable Thermostats Above

Outdoor temperature sensor	C0SNSR04AE1-
----------------------------------	--------------

Accessories For Digital Non-Programmable Thermostats Above

Optional wall mounting plate	C0MISC17AE1-
------------------------------------	--------------

WEIGHT DATA

Model Number	Net		Shipping	
	lbs.	kg	lbs.	kg
090/102 Base Unit	1220	553	1305	592
090/102 Max. Unit	1450	658	1335	696
120 Base Unit	1275	578	1360	617
120 Max. Unit	1495	678	1580	717
150 Base Unit	1310	594	1395	633
150 Max. Unit	1530	694	1615	733

OPTIONS / ACCESSORIES

		Weight	
		lbs.	kg.
CEILING DIFFUSERS			
Step-Down	RTD11-95	88	40
	RTD11-135	205	93
	RTD11-185	392	178
Flush	FD11-95	75	34
	FD11-135	174	79
	FD11-185	289	131
Transitions	LASRT08/10	30	14
	LASRT10/12	32	15
	LASRT15	36	16

ECONOMIZER / OUTDOOR AIR / EXHAUST

Economizer	LAREMD10/15	47	21
Barometric Relief			
Down-Flow Barometric Relief Dampers	LAGED10/15	8	4
Horizontal Barometric Relief Dampers	LAGEDH18/24	20	9
Outdoor Air Dampers			
Damper Section (down-flow) - Automatic	LAOADM10/15	31	14
Damper Section (down-flow) - Manual	LAOAD10/15	26	12
Outdoor Air Hood (down-flow)	LAOAH10/15	11	5
Power Exhaust	LAPEF10/15	28	13

PACKAGING

LTL Packaging (less than truck load)		105	48
--------------------------------------	--	-----	----

ROOF CURBS - STANDARD

Down-Flow			
14 in. height	LARMF10/15-14	126	57
24 in. height	LARMF10/15-24	174	79

ROOF CURBS - CLIPLOCK 1000

Down-Flow			
14 in. height	LARMF10/15S-14	115	52
18 in. height	LARMF10/15S-28	156	71
24 in. height	LARMF10/15S-24	189	86

ELECTRIC HEAT

7.5 to 15 kW		31	14
22.5 to 30 kW		38	17
45 kW		42	19
60 kW		49	22

Base Unit - The unit with low fire heat exchanger NO OPTIONS.

Max. Unit - The unit with ALL OPTIONS Installed. (High Input Heat Exchanger, Economizer, Power Exhaust Fans, Controls)

DIMENSIONS - INCHES (MM)

Model Number	CORNER WEIGHTS								CENTER OF GRAVITY			
	AA		BB		CC		DD		EE		FF	
	lbs.	kg	lbs.	kg	lbs.	kg	lbs.	kg	inch	mm	inch	mm
090/102 Base Unit	302	137	278	126	316	143	354	161	47	1194	21-1/2	546
090/102 Max. Unit	358	162	329	149	374	170	419	190	47	1194	21-1/2	546
120 Base Unit	319	145	286	130	324	147	376	171	46	1168	21-1/2	546
120 Max. Unit	373	169	334	152	379	172	439	199	46	1168	21-1/2	546
150 Base Unit	314	142	299	136	337	153	359	163	48-1/2	1232	22-1/2	572
150 Max. Unit	382	173	344	156	377	171	427	194	46-1/2	1181	24	610

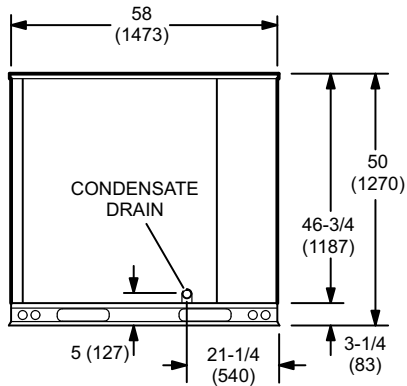
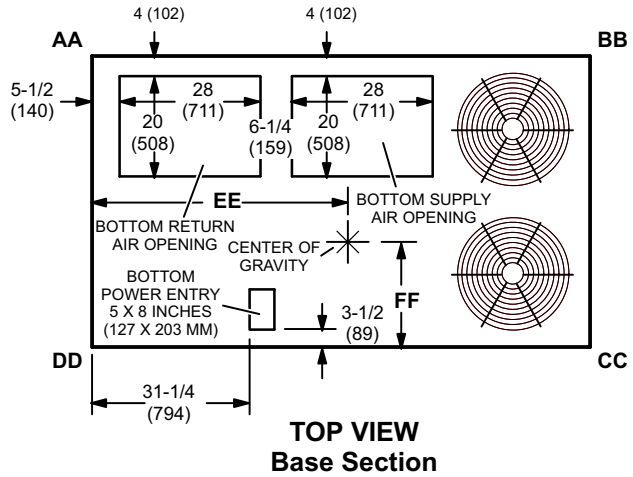

END VIEW

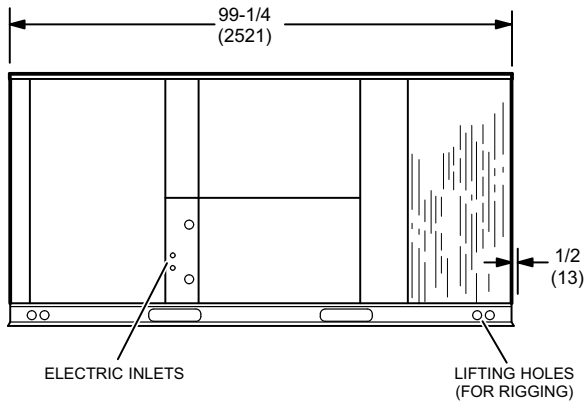

SIDE VIEW

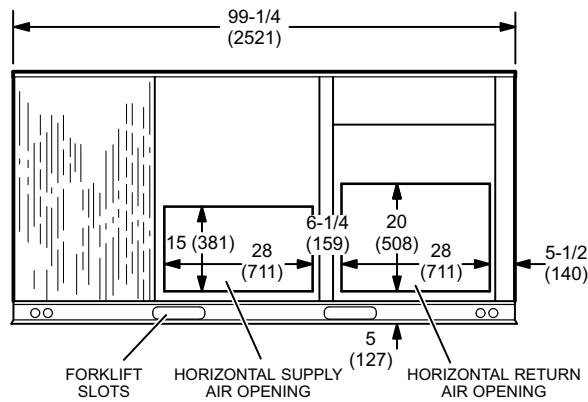

SIDE VIEW
(Horizontal Openings)

OPTIONAL OUTDOOR AIR HOOD DETAIL

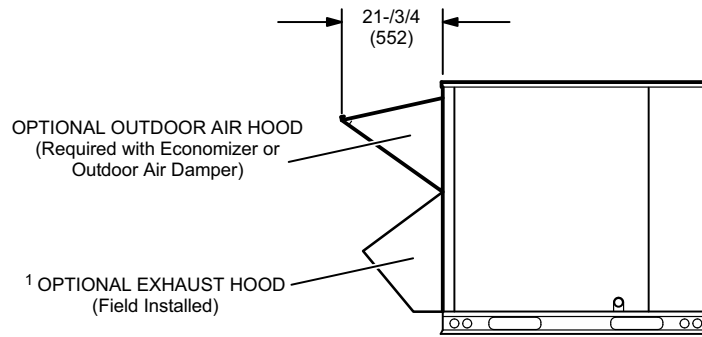

¹ NOTE — Field Installed in Return Air Duct for Horizontal Applications.

HORIZONTAL BAROMETRIC RELIEF DAMPERS
(Field installed in horizontal return air duct adjacent to unit)

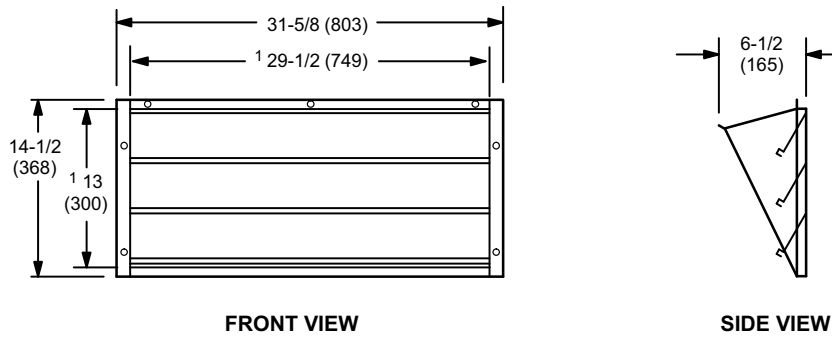

¹ NOTE - Opening size required in return air duct.

ACCESSORY DIMENSIONS - INCHES (MM)

CLIPLOCK 1000 ROOF CURBS - DOUBLE DUCT OPENING

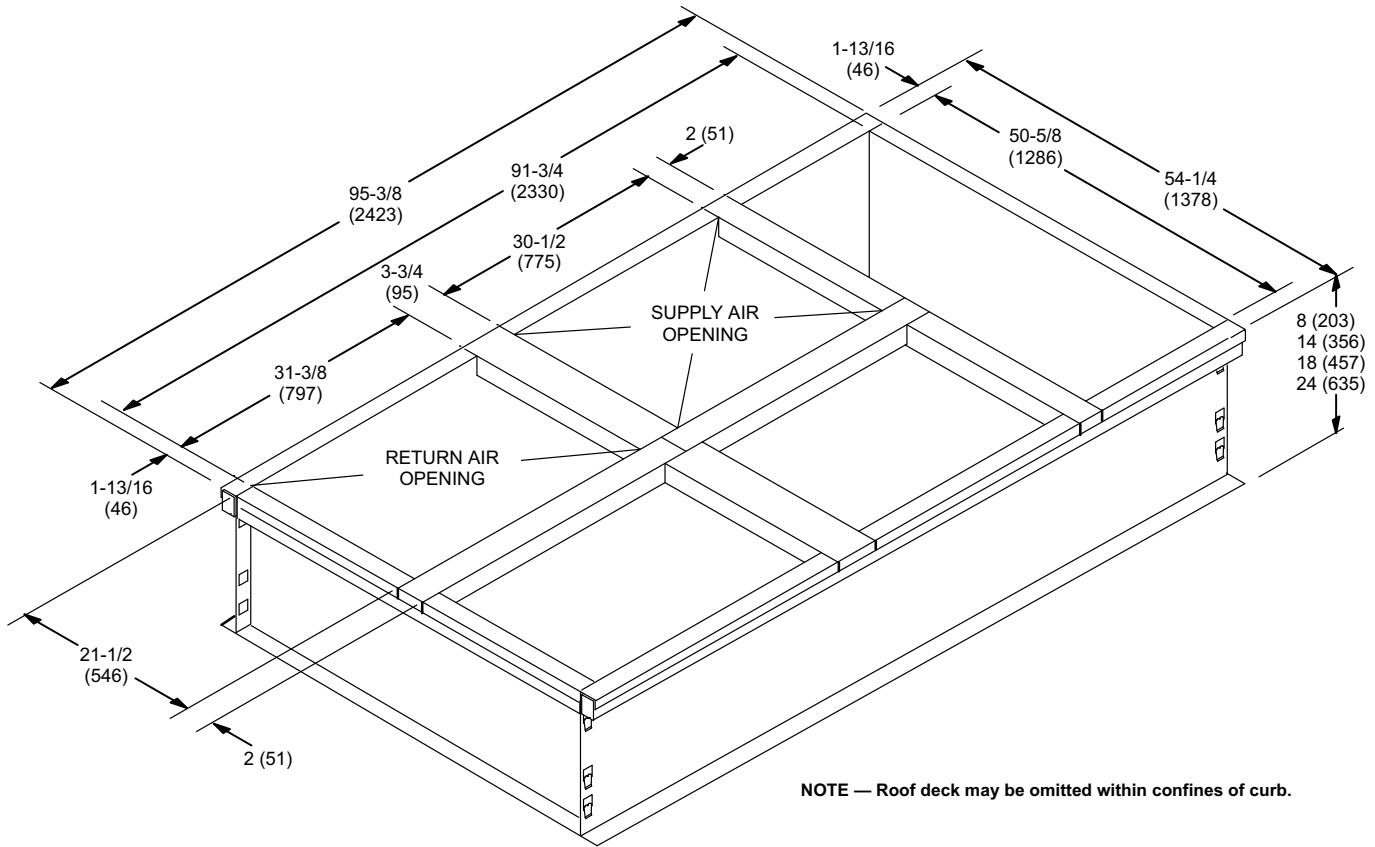

TYPICAL FLASHING DETAIL FOR ROOF CURB

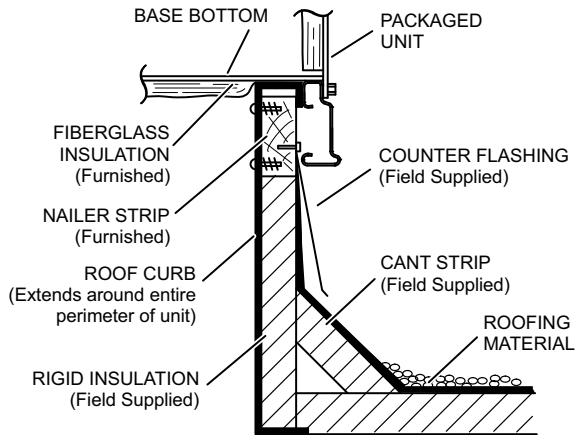

DETAIL ROOF CURB

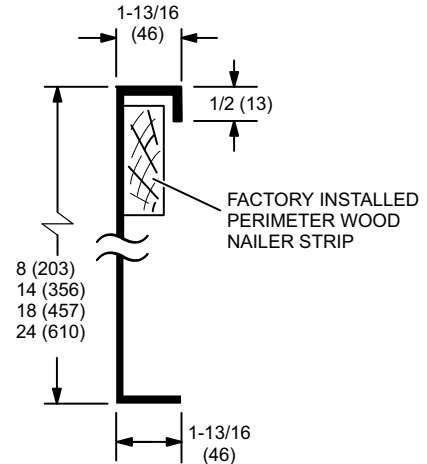

ACCESSORY DIMENSIONS - INCHES (MM)

STANDARD ROOF CURBS - DOUBLE DUCT OPENING

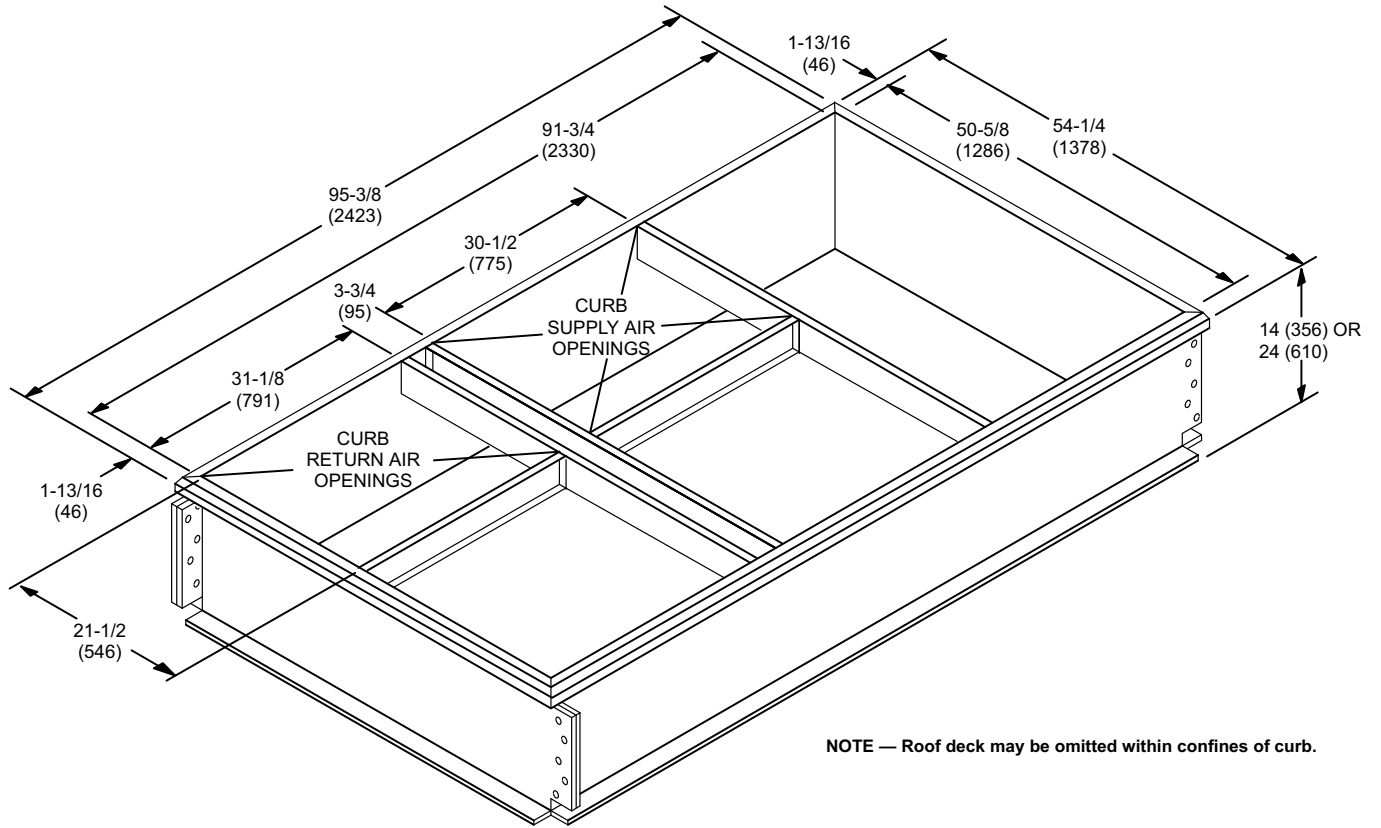

NOTE — Roof deck may be omitted within confines of curb.

TYPICAL FLASHING DETAIL FOR ROOF CURB

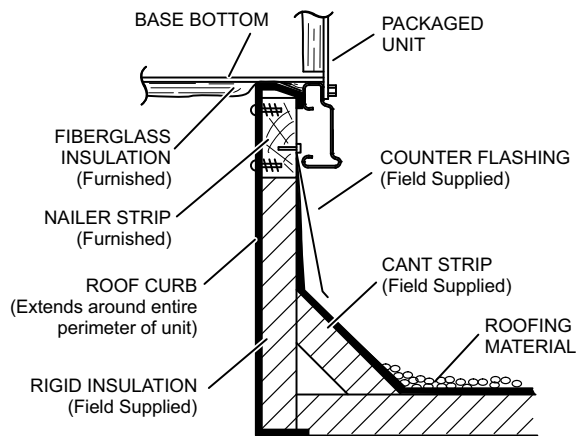

DETAIL ROOF CURB

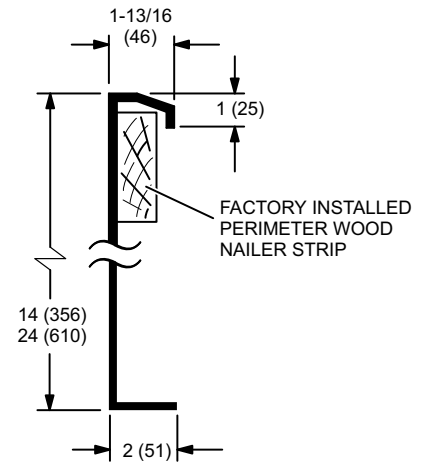

ACCESSORY DIMENSIONS - INCHES (MM)

ROOF CURBS WITH SUPPLY & RETURN AIR TRANSITIONS FOR CEILING DIFFUSERS

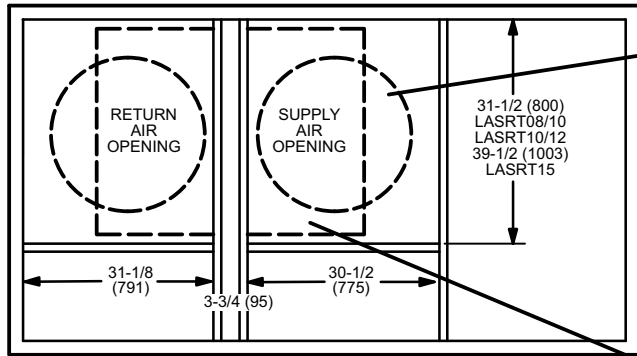

TOP VIEW

LASRT08/10 ROUND TRANSITIONS
(for 090 models with FD11-95, RTD11-95 Diffusers)

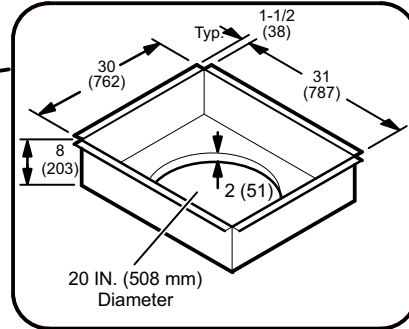

LASRT10/12 & LASRT15 RECTANGULAR TRANSITIONS
(for 102 thru 150 models with FD11-135-185, RTD11-135-185 Diffusers)

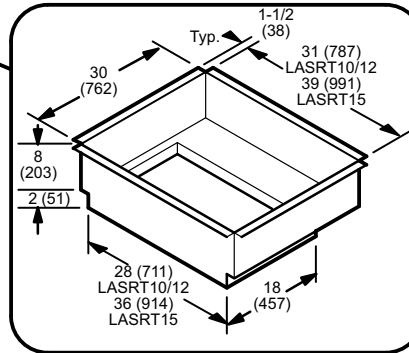

ACCESSORY DIMENSIONS - INCHES (MM)

COMBINATION CEILING SUPPLY AND RETURN DIFFUSERS

STEP-DOWN CEILING DIFFUSER

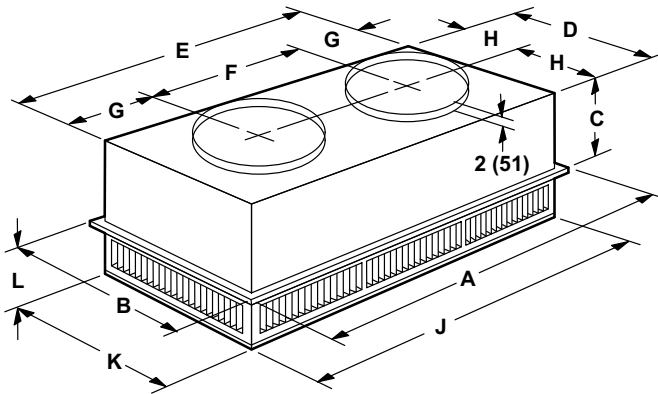

FLUSH CEILING DIFFUSER

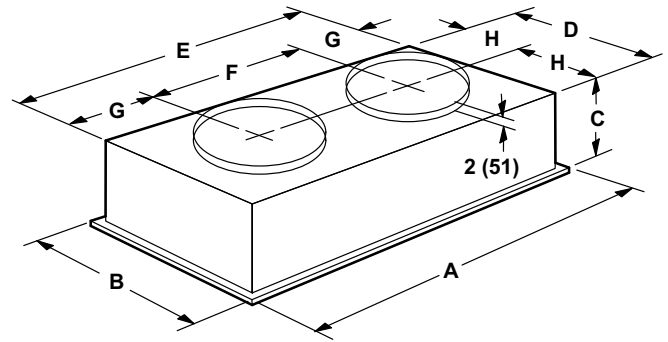

Model Number		RTD11-95
A	in.	47-5/8
	mm	1159
B	in.	29-5/8
	mm	752
C	in.	14-3/8
	mm	365
D	in.	27-1/2
	mm	699
E	in.	45-1/2
	mm	1158
F	in.	22-1/2
	mm	572
G	in.	11-1/2
	mm	292
H	in.	13-3/4
	mm	349
J	in.	45-1/2
	mm	1156
K	in.	27-1/2
	mm	699
L	in.	8-1/8
	mm	206
Duct Size	in.	20 round
	mm	508 round

Model Number		FD11-95
A	in.	47-5/8
	mm	1159
B	in.	29-5/8
	mm	752
C	in.	16-5/8
	mm	422
D	in.	27
	mm	686
E	in.	45
	mm	1143
F	in.	22-1/2
	mm	572
G	in.	11-1/4
	mm	286
H	in.	13-1/2
	mm	343
Duct Size	in.	20 round
	mm	508 round

ACCESSORY DIMENSIONS - INCHES (MM)

COMBINATION CEILING SUPPLY AND RETURN DIFFUSERS

STEP-DOWN CEILING DIFFUSER

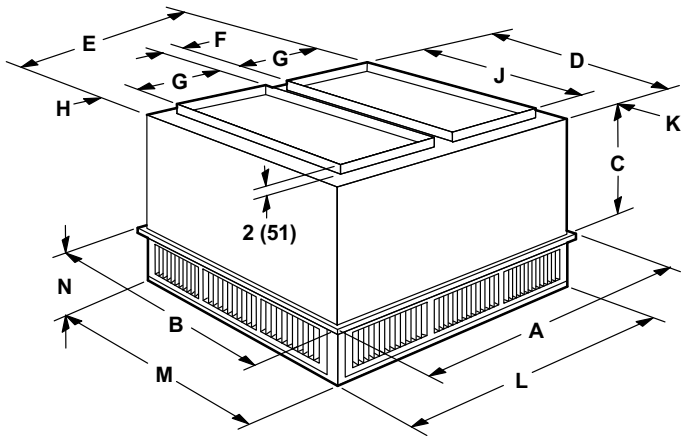

FLUSH CEILING DIFFUSER

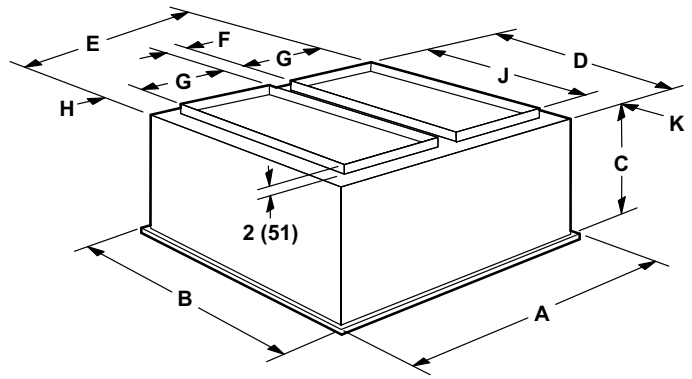

Model Number		RTD11-135	RTD11-185
A	in.	47-5/8	47-5/8
	mm	1210	1210
B	in.	35-5/8	47-5/8
	mm	905	1210
C	in.	20-5/8	24-5/8
	mm	524	625
D	in.	33-1/2	45-1/2
	mm	851	1156
E	in.	45-1/2	45-1/2
	mm	1156	1156
F	in.	4-1/2	4-1/2
	mm	114	114
G	in.	18	18
	mm	457	457
H	in.	2-1/2	2-1/2
	mm	64	64
J	in.	28	36
	mm	711	914
K	in.	2-3/4	4-3/4
	mm	70	121
L	in.	45-1/2	45-1/2
	mm	1156	1156
M	in.	33-1/2	45-1/2
	mm	851	1156
N	in.	9-1/8	10-1/8
	mm	232	257
Duct Size	in.	18 x 28	18 x 36
	mm	457 x 711	457 x 914

Model Number		FD11-135	FD11-185
A	in.	47-5/8	47-5/8
	mm	1210	1210
B	in.	35-5/8	47-5/8
	mm	905	1210
C	in.	23-1/4	29-1/4
	mm	591	743
D	in.	33	45
	mm	838	1143
E	in.	45	45
	mm	1143	1143
F	in.	4-1/2	4-1/2
	mm	114	114
G	in.	18	18
	mm	457	457
H	in.	2-1/4	2-1/4
	mm	57	57
J	in.	28	36
	mm	711	914
K	in.	2-1/2	4-1/2
	mm	64	114
Duct Size	in.	18 x 28	18 x 36
	mm	457 x 711	457 x 914

SECTION 15730**UNITARY AIR CONDITIONING EQUIPMENT****PART 1 GENERAL****PART 1.01 SUMMARY**

- A. Section Includes: Packaged rooftop units and commercial packaged, gas/electric, electric/electric and electric/heat pumps.

Specifier Note: Revise paragraph below to suit project requirements. Add section numbers and titles per CSI *MasterFormat* and specifier's practice.

- B. Related Sections:

Specifier Note: Article below may be omitted when specifying manufacturer's proprietary products and recommended installation. Retain Reference Article when specifying products and installation by an industry reference standard. If retained, list standard(s) referenced in this section. Indicate issuing authority name, acronym, standard designation and title. Establish policy for indicating edition date of standard referenced. Conditions of the Contract or Division 1 References Section may establish the edition date of standards. This article does not require compliance with standard, but is merely a listing of references used. Article below should list only those industry standards referenced in this section. Retain only those reference standards to be used within the text of this Section. Add and delete as required for specific project.

PART 1.02 REFERENCES

- A. Agency Listings:
1. Intertek ETL.
 2. Canadian Standards Association (CSA).
- B. Safety Standards:
1. Underwriters Laboratories (UL).
 2. Underwriters Laboratories of Canada (ULC).
 3. National Electric Code (NEC).
 4. Canadian Electric Code (CEC).
- C. Air-Conditioning and Refrigerating Institute (ARI):
1. ARI 340/360 Commercial and Industrial Unitary Air-Conditioning and Heat Pump Equipment.
 2. ARI 370 Sound Rating of Large Outdoor Refrigerating and Air Conditioning Equipment.
 3. ARI 210/240 Performance Rating of Unitary Air Conditioning and Air-Source Heat Pump Equipment.
- D. American Society for Testing and Materials (ASTM):
1. ASTM B117 – Standard Practice for Operating Salt Spray.
 2. ASTM 1153 – Standard Method for Methyl Isobutyl Ketone.
- E. ISO 9001, Quality Management Systems.
- F. Meet Military Specification MIL-P-53084

Specifier Note: Article below should be restricted to statements describing design or performance requirements and functional (not dimensional) tolerances of a complete system. Limit descriptions to composite and operational properties required to link components of a system together and to interface with other systems.

PART 1.03 SYSTEM DESCRIPTION

- A. Performance Requirements:

Specifier Note: Article below should be restricted to T-Class (TH), heat pumps packaged roof top units only.

1. [2, 2.5, 3, 4, 5, 6, 7.5, 8.5, 10, 12.5, 15 and 20 ton capacity.]

Specifier Note: Article below should be restricted to T-Class (TG) gas/electric packaged roof top units or T-Class (TC) electric/electric packaged roof top units.

2. [2, 2.5, 3, 4, 5, 6, 7.5, 8.5, 10, 12.5, 15, 17.5, 20 and 25 ton capacity.]
3. Electrical Characteristics:
 - a. 60 Hz

Specifier Note: 208/230 volt 1 phase is only available on 2, 2.5, 3, 4 and 5 ton standard efficiency models. All other voltages are available on 3-25 ton T-Class RTU's.

- b. [208/230 v – 1 Phase] [208/230 v – 3 Phase] [460 v – 3 Phase] [575 v – 3 Phase]

Specifier Note: Article below includes submittal of relevant data to be furnished by Contractor before, during or after construction. Coordinate this article with Architect's and Contractor's duties and responsibilities in Conditions of the Contract and Division 1 Submittal Procedures Section.

PART 1.04 SUBMITTALS

- A. General: Submit listed submittals in accordance with Conditions of the Contract and Division 1 Submittal Procedures.
- B. Product Data: Submit product data for specified products.

GUIDE SPECIFICATIONS

- C. Shop Drawings:
1. Submit shop drawings in accordance with Section 01330 - Submittal Procedures.
 2. Indicate:
 - a. Equipment, piping and connections, together with valves, strainers, control assemblies, thermostatic controls, auxiliaries and hardware, and recommended ancillaries which are mounted, wired and piped ready for final connection to building system, its size and recommended bypass connections.
 - b. Piping, valves and fittings shipped loose showing final location in assembly.
 - c. Control equipment shipped loose, showing final location in assembly.
 - d. Dimensions, internal and external construction details, recommended method of installation with proposed structural steel support, mounting curb details, sizes and location of mounting bolt holes; include mass distribution drawings showing point loads.
 - e. Detailed composite wiring diagrams for control systems showing factory installed wiring and equipment on packaged equipment or required for controlling devices or ancillaries, accessories and controllers.
 - f. Fan performance curves.
 - g. Details of vibration isolation.
 - h. Estimate of sound levels to be expected across individual octave bands in dB.
 - i. Type of refrigerant used.
 - j. Plan view, front view end view, back view and curb detail with dimensions.
- D. Quality Assurance:
1. Test Reports: Certified test reports showing compliance with specified performance characteristics and physical properties.
 2. Certificates: Product certificates signed by manufacturer certifying materials comply with specified performance characteristics and criteria and physical requirements.
 3. Manufacturer's Instructions: Manufacturer's installation instructions.

Specifier Note: Coordinate paragraph below with Part 3 Field Quality Requirements Article herein. Retain or delete as applicable.

- E. Manufacturer's Field Reports: Manufacturer's field reports specified.
- F. Closeout Submittals: Submit following:
1. Warranty: Warranty documents specified.
 2. Operation and Maintenance Data: Operation and maintenance data for installed products in accordance with Division 1 Closeout Submittals (Maintenance Data and Operation Data) Section. Include methods for maintaining installed products and precautions against cleaning materials and methods detrimental to finishes and performance. Include names and addresses of spare part suppliers.
 3. Provide brief description of unit, with details of function, operation, control and component service.
 4. Provide equipment inspection report and equipment operation test report.
 5. Commissioning Report: Submit commissioning reports, report forms and schematics in accordance with Section 01810 - Commissioning.

PART 1.05 QUALITY ASSURANCE

- A. Qualifications:
1. Installer experienced in performing work of this section who has specialized in installation of work similar to that required for this project.

PART 1.06 DELIVERY, STORAGE & HANDLING

- A. General: Comply with Division 1 Product Requirements.
- B. Ordering: Comply with manufacturer's ordering instructions and lead time requirements to avoid construction delays.
- C. Packing, Shipping, Handling and Delivery:
1. Deliver materials in manufacturer's original, unopened, undamaged containers with identification labels intact.
 2. Ship, handle and unload units according to manufacturer's instructions.
- D. Storage and Protection:
1. Store materials protected from exposure to harmful weather conditions.
 2. Factory shipping covers to remain in place until installation.

PART 1.07 PROJECT CONDITIONS

- A. Installation Location: **[Confirm design conditions and temperature.]**

Specifier Note: Coordinate article below with Conditions of the Contract and with Division 1 Closeout Submittals (Warranty).

PART 1.08 WARRANTY

- A. Project Warranty: Refer to Conditions of the Contract for project warranty provisions.
- B. Manufacturer's Warranty: Submit, for Owner's acceptance, manufacturer's standard warranty document executed by authorized company official. Manufacturer's warranty is in addition to, and not a limitation of, other rights Owner may have under Contract Documents.

GUIDE SPECIFICATIONS

Specifier Note: “Aluminized Heat Exchanger” and “Stainless steel Heat Exchanger” limited warranty is only available on T-Class (TG) Gas/Electric models. “Compressor” and “Other System Components” are covered on all T-Class units.

- C. Warranty: Commencing on Date of Installation.
 - 1. Compressors: 5 years (limited).
 - 2. Other Covered System Components: 1 year (limited).
 - 3. [Aluminized Heat Exchangers: 10 years (limited).] [Stainless Steel Heat Exchangers: 15 years (limited).]

PART 2 PRODUCTS

Specifier Note: Retain article below for proprietary method specification. Add product attributes, performance characteristics, material standards and descriptions as applicable. Use of such phrases as “or equal” or “or approved equal” or similar phrases may cause ambiguity in specifications. Such phrases require verification (procedural, legal and regulatory) and assignment of responsibility for determining “or equal” products.

PART 2.01 ROOFTOP UNITS

- A. Manufacturer: Lennox Industries.
 - 1. Contact: 2100 Lake Park Blvd., Richardson, TX 75080; Telephone: (800) 453-6669; website: www.lennox.com.
- B. Proprietary Products/Systems: Lennox T-Class Packaged Rooftop Units, including the following equipment:
 - 1. Cabinet:
 - a. Heavy gauge steel panels.
 - b. Pre-painted steel panels.
 - c. Heavy Gauge galvanized steel base rail.
 - d. Rigging holes on all four corners.
 - e. Forklift slots (on three sides, not directly below condenser coil) on base rail.
 - f. Raised or flanged edges around duct and power entry openings.

Specifier Note: “Down Flow” is the standard configuration that all T-Class units are shipped as.

Specifier Note: “Horizontal Flow” is an option for all T-Class models. T-Class TH, TG and TC models of tonnages 2, 2.5, 3, 4, 5 and 6 can be converted, in the field, to horizontal flow without the need of a conversion kit. If applied horizontally with an economizer, a conversion kit is required.

Specifier Note: “Horizontal Flow” is an option for all T-Class models. T-Class TH, TG and TC models of tonnages 7.5, 8.5, 10 and 12.5 can be converted, in the field, with a separate to Horizontal Conversion Kit.

Specifier Note: “Horizontal Flow” is an option for all T-Class models. T-Class TH, TG and TC models of tonnages 15, 17.5, 20 and 25 require a roof curb that allows for horizontal air flow. A Horizontal Air Panel Kit is also required if converting a down-flow configured unit to horizontal air flow.

- g. [Down-Flow] [Horizontal] Air Flow configuration

Specifier Note: add the “and gas lines” only if using a T-Class (TG) gas/electric model.

- h. Electrical lines [and gas lines] can be brought through the base of the unit or through horizontal knockouts.
- i. Insulation:
 - 1) All panels adjacent to conditioned air are fully insulated with non-hygroscopic fiberglass insulation.
 - 2) Unit base is fully insulated.
 - 3) Unit base insulation also serves as a roof curb seal.
- j. Access Panels:
 - 1) Provided for economizer/filter section.
 - 2) Provided for Heating/blower section.
- k. Condensate Drain Pan.

Specifier Note: “Factory Installed Options” are options that can be selected for the T-Class roof top units. The “Factory Installed Options” are installed at the Lennox manufacturing facility.

- l. [Factory Installed Options:]
 - 1) [Corrosion Protection, meets standards:
 - a) Military Specification MIL-P-53084.
 - b) ASTM B117
 - c) ASTM 1153]
 - 2) [Hinged Access panels]
 - 3) [GFI Service Outlets (field wired)]

Specifier Note: “Field Installed Accessories” are options that can be selected for the T-Class roof top units. The “Field Installed Accessories” are shipped separately and installed in the field.

- m. [Field Installed Accessories:]

GUIDE SPECIFICATIONS

Specifier Note: Of the selections below, [Coil Guards] [Hail Guards], only one can be selected.

- 1) [Coil Guards] [Hail Guards].
- 2) [Horizontal Return Air Panel Kit].

Specifier Note: "Circuit Breakers(up to 175 amps)" is not available on 2-6 ton models.

- 3) [Circuit Breakers (up to 175 amps)]
 - 4) [Disconnect Switch (up to 250 amps)]
 - 5) [Condensate drain trap]
2. Cooling System:
- a. Capable of operating from 30 - 125 degrees F (-1 - 52 degrees C) without installation of additional controls.
 - b. Compressors:

Specifier Note: The TG/TC036B unit uses a reciprocating compressor instead of a scroll type.

- 1) Scroll Type.
 - 2) Resiliently mounted on rubber mounts for vibration isolation.
 - 3) Overload Protected
 - 4) Internal excessive current and temperature protection.
 - 5) Isolated from condenser fan air stream.
 - 6) Refrigerant cooled.
- c. TXV
 - d. Freezestat
 - e. High capacity filter driers

Specifier Note: Include following 2 articles for T-Class (TH) packaged heat pumps models.

- f. Reversing Valves: Four-way interchange reversing valve.
- g. Defrost Control.

Specifier Note: 2-2.5 ton models are only available in Standard efficiency, 3-6 ton models are available in Basic or Standard efficiencies only, and 7.5-20 ton models are available in Standard or High efficiencies only.

Specifier Note: The 12.5 ton model is available in standard efficiency only.

- h. Efficiency: [Basic] [and]/[or] [Standard] [and]/[or] [High].
- i. [Low ambient kit: Field installed]

Specifier Note: High pressure switch is available to be field installed on all units except the T-Class model TH on tonnages 15-20.

- j. [High pressure switch: Field installed]

Specifier Note: Crankcase heater is available to be field installed on all units except the T-Class model TH on tonnages 2-6 and 15-20.

- k. [Crankcase heater: field installed]
3. Coil Construction:
- a. Condensing/evaporator coil general construction:
 - 1) Aluminum Rippled and Lanced fins.
 - 2) Copper tube construction.
 - 3) Aluminum fins mechanically bonded to copper tubes.
 - 4) All coils are high pressure leak tested at manufacturing facility.
 - b. Evaporator Coils:
 - 1) With balanced port thermal expansion valves, freeze protection on each compressor circuit, pressure and leak tested to 500 psi, and maximum 14 fins per inch.
 - 2) Each compressor circuit on coil divided across face of coil and active through full depth of coil.
 - 3) [With flexible immersed coating electrodeposited by dry film process].
 - c. Condenser Coils:
 - 1) [With flexible immersed coating electrodeposited by dry film process] on corrosion hardened units only.

GUIDE SPECIFICATIONS

4. Wiring:
 - a. Color coded and continuously marked to identify point-to-point component connections.
 - b. Not in contact with hot-gas refrigerant lines or sharp metal edges.
5. Cooling Controls:
 - a. Provide minimum compressor on time of 4 minutes.

Specifier Note: “4 Stages of cooling from thermostat” is only available for models that have 4 independent refrigerant circuits. 2-6 ton models have 1 circuit, 7.5-12.5 ton models have 2 circuits, and 15-25 ton models have several models with 4 circuits.

- b. Support up to 4 stages of cooling from thermostat or external DDC controller. (4 independent refrigerant circuits required.)

Specifier Note: T-Class units with Gas Heating Systems are TG models.

6. Gas Heating System:
 - a. Induced draft
 - b. Natural gas fired system with direct spark ignition
 - c. Electronic flame sensors
 - d. Flame rollout switches
 - e. High heat limit switches
 - f. Induced draft failure switch and capable of operating to altitude of 2000 feet (610 m) with no derate to manifold pressure.
 - g. Service access for controls, burners and heat exchanger.
 - h. Heat Exchanger:
 - 1) Tubular Design
 - 2) **[Aluminized steel] [Stainless steel].**
 - i. Gas piping system tight and free of leaks when pressurized to maximum supply pressure.
 - j. Gas Valve: Two-stage, redundant type gas heat valve with manual shutoff.

Specifier Note: One Stage Gas valve only available on 2-6 ton models.

- k. Gas Valve: Single-stage.
 - l. Gas Burners: Aluminized steel inshot-type gas burners.
 - m. Direct spark pilot ignition.
 - n. Fan and Limit Controls.
 - o. Safety Switches.
 - p. Gas piping system tight and free of leaks when.

Specifier Note: “Cold Weather Kit” is only available for field mounting on the T-Class (TG) Gas/Electric models of tonnages 15 – 25 or factory mounting on the T-Class (TG) Gas/Electric models of tonnages 7.5 – 12.

- q. **[Cold Weather Kit:] [field] [factory]**

Specifier Note: “Field Installed Accessories” are options that can be selected for the T-Class TG Gas/Electric models. The “Field Installed Accessories” are shipped separately and installed in the field.

- r. **[Field Installed Accessories:]**
 - 1) **[Combustion Air Intake Extensions].**
 - 2) **[Vertical Vent Extension Kit].**
 - 3) **[LPG/Propane Kit].**

Specifier Note: “Low Temperature Vestibule Heater” is only available for the T-Class (TG) Gas/Electric models of tonnages 2, 2.5, 3, 4, 5 and 6.

- 4) **[Low Temperature Vestibule Heater].**

Specifier Note: The “Electric Heating System” is an option for T-Class (TH), heat pump, and T-Class (TC), electric/electric models only. The “Electric Heating System” can be either factory or field installed.

7. Electric Heating System:
 - a. Electrical resistance heater.
 - b. **[Factory] [Field] installed.**
 - c. **[Factory] [Field] installed Fuse Block.**
 - d. Reset thermal limit protection.
 - e. Single point power supply.
 - f. Heater Element:
 - 1) Nickel chromium wire.
 - 2) Individually fused.

GUIDE SPECIFICATIONS

- g. Electric heater slides out of unit for service.
- 8. Heating Controls:

Specifier Note: 2 stages of heating control are only available on T-Class (TG) gas/electric models of tonnages 4-6, on two stage units.

- a. Support 2 stages of heating control from thermostat or DDC.
- b. With delay time of 30 seconds between low and high heat stages.
- 9. Supply Air Fan Motor and Drives:
 - a. Permanently lubricated ball bearings (for belt drive motors).
 - b. Thermal overload protected motors with automatic reset.

Specifier Note: Slide out accessibility is only available on T-Class models of tonnages 7.5-25.

- c. Adjustable sheaves on belt drive motors for blower speed adjustment.
- d. Optional low and high static motor/drive combinations and optional drive kits.
- 10. Supply Air Fan:
 - a. Double inlet type, G90 (Z275) galvanized steel with forward curved blades.
 - b. Statically and dynamically balanced.
 - c. Slide-out accessibility unit for servicing and belt tension adjustment.
 - d. Continuous or automatic control for occupied periods.
- 11. Supply Air Filters:
 - a. Disposable 2 inch.

Specifier Note: Permanent metal frame filters with 2 inch polyester replaceable media are only available on T-Class models of tonnages 15-25 tons.

- b. [Permanent metal frame filters with 2 inch polyester replaceable media].
- 12. Condenser Fan Motor:

Specifier Note: T-Class 2-4 ton models have sleeve bearings.

- a. Direct drive with permanently lubricated ball bearings.
- b. Watertight with thermal overload protection and automatic reset.
- c. Motor mount isolated from fan safety guard.
- 13. Condenser Fans:
 - a. Corrosion resistant propeller type with vertical discharge and finger safety guard.
- 14. Microprocessor Based Unit Controller System:
 - a. Solid state, microprocessor based control board to control unit cooling operations.
 - b. Green blinking LED to indicate normal operation.
 - c. Pushbutton reset.
 - d. Four-position DIP switch to select unit operating mode/unit type.
 - e. Test mode for quick operation checks.
 - f. Up to 2-stage heat/4-stage cool thermostat or DDC capable thermostat operation.
 - g. Digital Inputs:
 - 1) Low cool demand
 - 2) High cool demand
 - 3) Low heat demand
 - 4) Supply fan demand
 - 5) Primary heat limit (2)
 - 6) Flame rollout switch (2)
 - 7) Induced draft motor switch (2)
 - 8) Gas valve sense switch (2)

Specifier Note: T-Class models of tonnages 15-25 have four Freeze protection switches. 7.5 - 12 ton models have two. 2-6 ton models have one.

- 9) Freeze protection switch (2), (4).
- h. Digital Outputs:
 - 1) Supply air fan motor
 - 2) compressor 1
 - 3) compressor 2
 - 4) condenser fans
 - 5) inducer fan motor 1

Specifier Note: T-Class 7.5 - 25 ton models only.
T-Class Packaged Heat Pump 7.5 to 12.5 tons / Page 36

GUIDE SPECIFICATIONS

- 6) heat 1
- 7) critical diagnostic fault code occurrence.

i. **[Control Options:]**

- 1) **[Single Enthalpy Control] : [Field] [Factory]**
- 2) **[Differential Enthalpy Control : Field]**

Specifier Note: The factory mounted CO2 sensor is only available T-Class models of tonnages 15 - 25. All other models can be field mounted only.

- 3) **[CO2 Sensor:] [Field] [Factory]**

Specifier Note: Economizer Control: Field is only available for T-Class models of tonnages 7.5 - 25.

- 4) **[Economizer Control: Field]**

15. **[Accessories:]**

- a. **[Economizer]: [Field] [Factory]**

Specifier Note: Motorized outdoor air damper is only available in a field mounted version for the T-Class models of tonnages 2, 2.5, 3, 4, 5 and 6. All other models can be factory or field.

- b. **[Motorized outdoor air damper]: [Field] [Factory]**

Specifier Note: Manual outdoor air damper is only available in a field mounted version for the T-Class models of tonnages 2, 2.5, 3, 4, 5 and 6. All other models can be factory or field.

- c. **[Manual outdoor air damper]: [Field] [Factory]**

Specifier Note: Barometric relief damper is included with factory or field installed economizer on 2-6 ton models. All other models can be factory or field installed separately.

- d. **[Barometric relief damper]: [Field] [Factory]**

Specifier Note: The factory mounted Power Exhaust Fan is only available on the versions of T-Class models of tonnages 15-25. All other models can be field mounted.

- e. **[Power exhaust fan]: [Field] [Factory]**

- f. **[Dirty filter switch: Field]**

Specifier Note: The field mounted Blower Proving Switch is only available on T-Class models of tonnages 7.5-25.

- g. **[Blower proving switch]: [Field] [Factory]**

- h. **[Smoke detectors: Field]**

- i. **[Roof curb: Field]**

- j. **[Outdoor air hood: Field]**

- k. **[Barometric relief damper hood: Field]**

Specifier Note: Edit article below to suit project requirements. If substitutions are permitted, edit text below. Add text to refer to Division 1 Project Requirements (Product Substitutions Procedures) Section.

PART 2.02 PRODUCT SUBSTITUTIONS

- A. Substitutions: No substitutions permitted.

PART 3 EXECUTION

PART 3.01 MANUFACTURER'S INSTRUCTIONS

Specifier Note: Revise article below to suit project requirements and specifier's practice.

- A. Compliance: Comply with manufacturer's written data, including product technical bulletins, product catalog installation instructions, product carton installation instructions and manufacturer's SPEC-DATA® sheets.

PART 3.02 EXAMINATION

- A. Site Verification of Conditions: Verify substrate conditions, which have been previously installed under other sections, are acceptable for product installation in accordance with manufacturer's instructions

PART 3.03 INSTALLATION

- A. Install **[Packaged rooftop units] [And] [Commercial packaged, gas/electric, electric/electric and electric/heat pumps]** in accordance with manufacturer's instructions **[On roof curbs provided by manufacturer] [As indicated]**.

END OF SECTION

REVISIONS

Sections	Description of Change
Dimensions	Updated Diffuser dimension drawings.
Optional Accessories	Updated Information - Economizer, High Pressure Switch, Low Ambient Kit.
Sound Data	Octave Band Sound Power Levels updated.



VERIFIED
ENERGY
PERFORMANCE



VERIFIE
RENDEMENT
ENERGETIQUE



Visit us at www.lennox.com
For the latest technical information, www.lennoxcommercial.com
Contact us at 1-800-4-LENNOX

NOTE - Due to Lennox' ongoing commitment to quality, Specifications, Ratings and Dimensions subject to change without notice and without incurring liability. Improper installation, adjustment, alteration, service or maintenance can cause property damage or personal injury. Installation and service must be performed by a qualified installer and servicing agency.

©2008 Lennox Industries Inc.