

### Applications

- Applicable to most forced air installations.
- Installs on return air plenum or duct and connects to the supply plenum or duct with flexible pipe provided.
- Right or left hand air flow available.
- Humidifier shipped in one package. All components shipped loose and field installed.

### Sequence of Operation

- By-passed supply (warm) air flows through the cylindrical polyester foam filter media.
- Air is moistened as it rotates through the water reservoir.
- Air re-enters air stream on the return side.

### Cabinet

- Rugged one piece molded plastic.
- Water tight and corrosion resistant.
- Large front access door, permits total access when removed.
- Colored to match Lennox furnaces.
- Humidifier service instructions molded inside of door.

### Polyester Foam Filter Media

- Provides large evaporation capacity.
- Easy to clean.
- Cylindrical shaped media slips off and on plastic drum for servicing.
- Drum hub equipped with slip clutch to prevent damage to motor if drum assembly rotation is stopped during operation.
- Slip clutch will rotate in drum hub creating a signal indicating a need for service.

### Overflow Drain Furnished

- Molded drain fitting in bottom of cabinet.
- Drain hose and clamp provided.

### Damper Starting Collar

- 6 inch (152 mm) starting collar with damper/air scoop furnished for supply air connection in plenum or duct.
- Pull chain for manual closing.
- Flexible 6 inch (152 mm) pipe and clamps furnished for connection to inlet collar on humidifier.

### Motor

- Permanently lubricated with brass gears for long life.
- Factory installed in molded plastic housing for protection against moisture.
- Electrical inlet provided in housing for power supply.

### Teflon Seated Float Valve

- Corrosion proof.
- Shuts off water when water reservoir is filled to capacity.
- Water level is adjustable.

### Water Reservoir

- Constructed of polystyrene to resist corrosion.
- Easy to service.

### Saddle Valve Furnished

- All necessary fittings furnished as standard equipment.
- Field installs in the water supply line.

### Transformer Furnished

- 20VA (120/24 VAC) is furnished as standard equipment.
- Mounts in or near furnace wiring junction box.

### Humidistat Furnished

- Can be mounted on wall or duct.
- Provides automatic control of room relative humidity.
- Wired in series with the humidifier motor.
- Has adjustable setting.

### OPTIONAL ACCESSORIES (Must Be Ordered Extra)

#### Filter Media (21307)

- Replaces Polyester Foam Filter Media when necessary.

#### Deluxe Humidistat

- Can be mounted on wall or duct.
- Outdoor temperature and corresponding recommended humidity settings on face plate for reference.



### Typical Applications

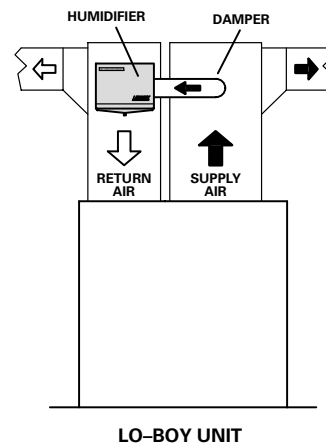
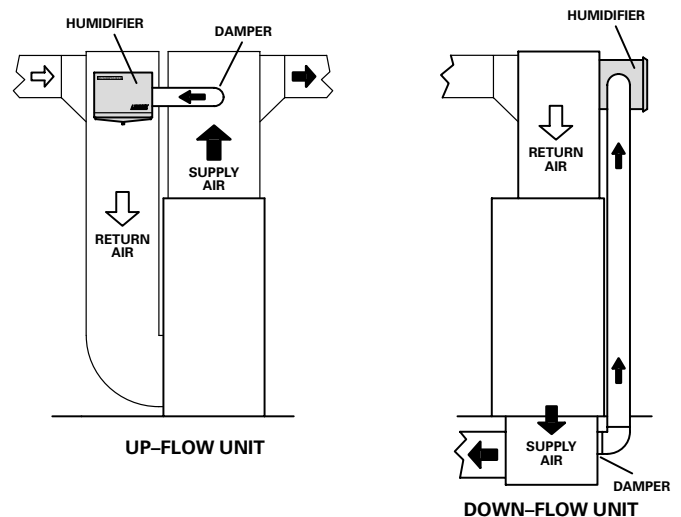
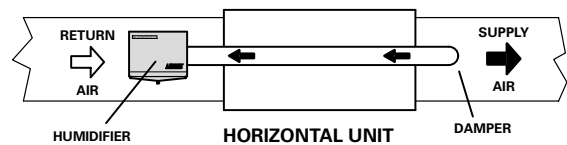

## SPECIFICATIONS

Model No.	*WD1-15
Filter media size – in. (mm)	6-3/4 x 8 x 1/2 (171 x 202 x 13)
Water supply connection – in. (mm)	1/4 (6) compression
Overflow connection – in. (mm)	3/4 (19) I.D.
Motor operating watts	5
Electrical characteristics	24v – 60hz – 1ph
Shipping weight – lbs. (kg) (1 pkg)	11 (5)

\*Rated at 18 U.S. gallons (68L) per day evaporation; 140°F (60°C) supply air temperature, .20 in. w.g. (50 Pa) static pressure and 30% return air relative humidity.

## DIMENSIONS – inches (mm)

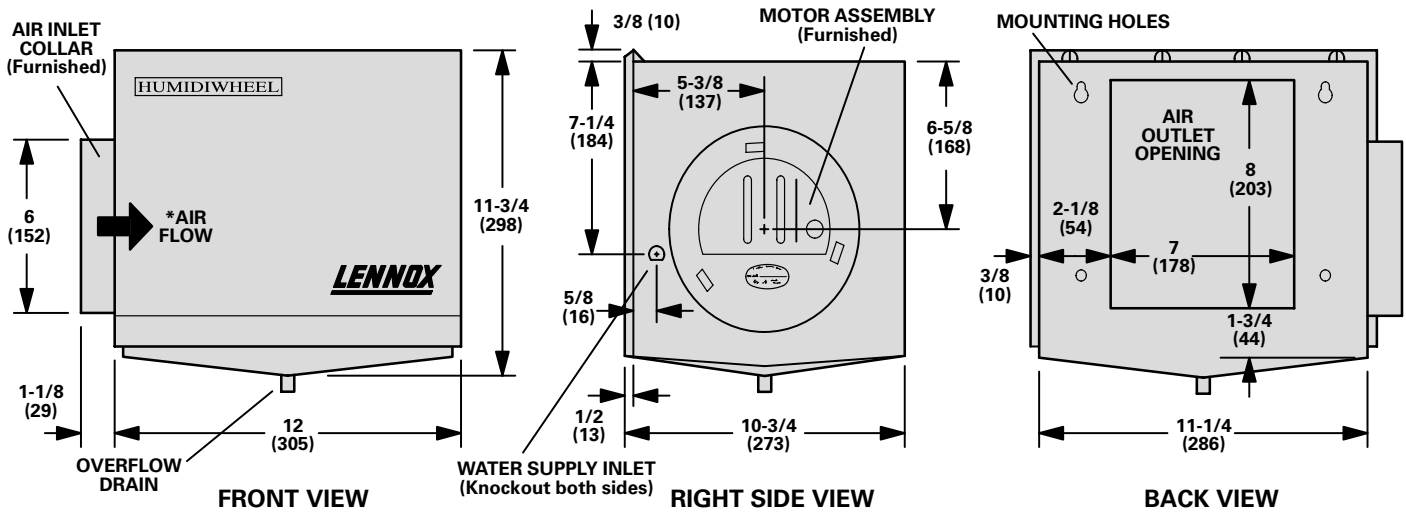

\*NOTE – Left hand inlet air shown. Relocate inlet collar and motor assembly to obtain right hand inlet air.

## PERFORMANCE DATA

