



SUBMITTAL DATA – OUTDOOR
UNIT MLA036S4M-1P
MULTI-ZONE MINI-SPLIT HEAT PUMP

Job: _____
Location: _____
Schedule No.: _____
System Designation: _____

Engineer: _____
Architect: _____
Date: _____
For: Reference Approval Review Construction

FEATURES

Outdoor Unit: MLA036S4M-1P

Indoor Unit Options: Ducted OR Non-Ducted



- Defrost Control
- DC Inverter Control
- Base Pan Heater
- Crankcase Heater

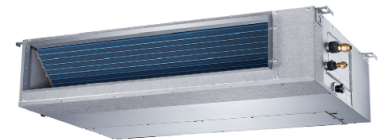

Piping

Line Set and Elevation Guidelines

Maximum Number of Indoor Units/Zones	4
Liquid + Gas pipe (flare)	(3) 1/4 liq. + (3) 3/8 gas (1) 1/4 liq. + (1) 1/2 gas
Maximum Pipe Length ft. (m)	262 ft. (80 m)
Maximum Line Set Length - Furthest Indoor Unit	115 ft. (35 m)
Maximum Elevation - Outdoor Unit Below/Above Indoor Unit ft. (m)	49 ft. (15m)
Pre-Charged (ft.)	25 ft.
Additional Charge of Refrigerant (oz/ft.)	0.32

PRODUCT WARRANTY

Compressor – Twelve year limited warranty*
 All other covered components - Twelve year limited warranty*
 *Product registration required

OPTIONAL ACCESSORIES

Hail Guards (M9GARD18Q-1)
 Mini-Split IDU Controls Wiring Harness (19P86)*
 *Required for BACnet & Lennox VRF Manager (LVM)



NOTE – Due to Lennox' ongoing commitment to quality, Specifications, Ratings, and Dimensions are subject to change without notice and without incurring liability. Improper installation, adjustment, alteration, service or maintenance can cause property damage or personal injury. Installation and service must be performed by a qualified installer and servicing agency.



SUBMITTAL DATA – OUTDOOR
UNIT MLA036S4M-1P
MULTI-ZONE MINI-SPLIT HEAT PUMP

OUTDOOR SPECIFICATIONS

PERFORMANCE

Cooling Capacity (Btu/h) ¹	Ducted	36,000
	Non-Ducted	36,000
EER	Ducted	11.3
	Non-Ducted	13.5
SEER	Ducted	19.0
	Non-Ducted	21.5
Heating Capacity (Btu/h) ¹	Ducted	37,000
	Non-Ducted	36,000
HSPF	Ducted	11.0
	Non-Ducted	10.5
Outdoor Fan Total Air Volume (CFM)		(2) 4470
Ambient Temperature Operating Range		
Cooling		-22 - 122°F
Heating		-22 - 86°F

ELECTRICAL DATA

Power Supply (V/Hz/φ)	208-230/60/1
Minimum Circuit Ampacity (A)	35.0
Maximum Overcurrent Protection (A)	50.0
Outdoor Fan Motor RLA (A)	1.0
Compressor RLA (A)	21
No. of Compressors	1

GENERAL DATA

Connection Ratio (%)	66% to 133%
Max. # of Indoor Units	Up to 4 units
Sound Data (dBA) - Cooling/Heating	64/64
Refrigerant type	R-410A
Factory refrigerant charge	10 lbs. 2 oz.

DIMENSIONS

Unit Dimensions (in)	Height	52-1/2
	Width	41-1/8
	Depth	16-3/8
Shipping Weight (lb)		255
Net Weight (lb)		224

NOTES

- Cooling and Heating Capacity data is rated at the following conditions:
Cooling: 80°FDB / 67°FWB Indoor, 95°FDB Outdoor
Heating: 70°FDB Indoor, 47°FDB / 43°FWB Outdoor

NOTE – Due to Lennox' ongoing commitment to quality, Specifications, Ratings, and Dimensions are subject to change without notice and without incurring liability. Improper installation, adjustment, alteration, service or maintenance can cause property damage or personal injury. Installation and service must be performed by a qualified installer and servicing agency.



SUBMITTAL DATA – OUTDOOR
UNIT MLA036S4M-1P
MULTI-ZONE MINI-SPLIT HEAT PUMP

Multi-Zone System Combinations

Outdoor Unit Model No.	Number of Zones	Indoor Unit Capacity				Nominal Cooling Capacity at Rated System Capacity (Btuh)				Nominal Heating Capacity at Rated System Capacity (Btuh)			
		#1	#2	#3	#4	#1	#2	#3	#4	#1	#2	#3	#4
MLA036S4M	2	009	018	---	---	9,500	17,500	---	---	10,000	18,000	---	---
		009	024	---	---	9,000	24,000	---	---	10,000	25,000	---	---
		012	012	---	---	12,000	12,000	---	---	13,000	13,000	---	---
		012	018	---	---	12,000	18,000	---	---	13,000	18,000	---	---
		012	024	---	---	11,000	23,000	---	---	12,000	24,000	---	---
		018	018	---	---	16,500	16,500	---	---	17,000	17,000	---	---
		018	024	---	---	16,000	22,000	---	---	16,500	22,500	---	---
		024	024	---	---	20,000	20,000	---	---	21,000	21,000	---	---
	3	009	009	009	---	9,333	9,333	9,333	---	9,667	9,667	9,667	---
		009	009	012	---	9,000	9,000	12,000	---	9,500	9,500	12,500	---
		009	009	018	---	8,000	8,000	16,000	---	8,500	8,500	17,000	---
		009	009	024	---	7,500	7,500	21,000	---	8,500	8,500	22,000	---
		009	012	012	---	8,500	11,500	11,500	---	9,000	12,000	12,000	---
		009	012	018	---	8,000	11,000	15,000	---	8,500	11,500	16,000	---
		009	012	024	---	7,500	10,500	19,000	---	8,000	11,000	19,500	---
		009	018	018	---	8,000	14,000	14,000	---	8,500	14,500	14,500	---
		012	012	012	---	11,333	11,333	11,333	---	12,000	12,000	12,000	---
		012	012	018	---	11,000	11,000	14,000	---	12,000	12,000	15,000	---
		012	012	024	---	10,000	10,000	18,000	---	10,500	10,500	18,500	---
		012	018	018	---	9,333	13,333	13,333	---	10,000	14,500	14,500	---
	4	009	009	009	009	9,000	9,000	9,000	9,000	9,500	9,500	9,500	9,500
		009	009	009	012	8,500	8,500	8,500	11,500	9,000	9,000	9,000	12,000
		009	009	009	018	8,000	8,000	8,000	14,000	8,500	8,500	8,500	14,000
		009	009	012	012	8,000	8,000	10,500	10,500	8,500	8,500	11,000	11,000
		009	009	012	018	7,500	7,500	9,000	14,000	8,000	8,000	9,500	14,500
		009	012	012	012	7,000	10,000	10,000	10,000	8,000	10,500	10,500	10,500
		012	012	012	012	9,500	9,500	9,500	9,500	10,000	10,000	10,000	10,000

NOTE – Due to Lennox' ongoing commitment to quality, Specifications, Ratings, and Dimensions are subject to change without notice and without incurring liability. Improper installation, adjustment, alteration, service or maintenance can cause property damage or personal injury. Installation and service must be performed by a qualified installer and servicing agency.



SUBMITTAL DATA - OUTDOOR
UNIT MLA036S4M-1P
MULTI-ZONE MINI-SPLIT HEAT PUMP

OUTDOOR DIMENSIONAL DRAWINGS - INCHES (MM)

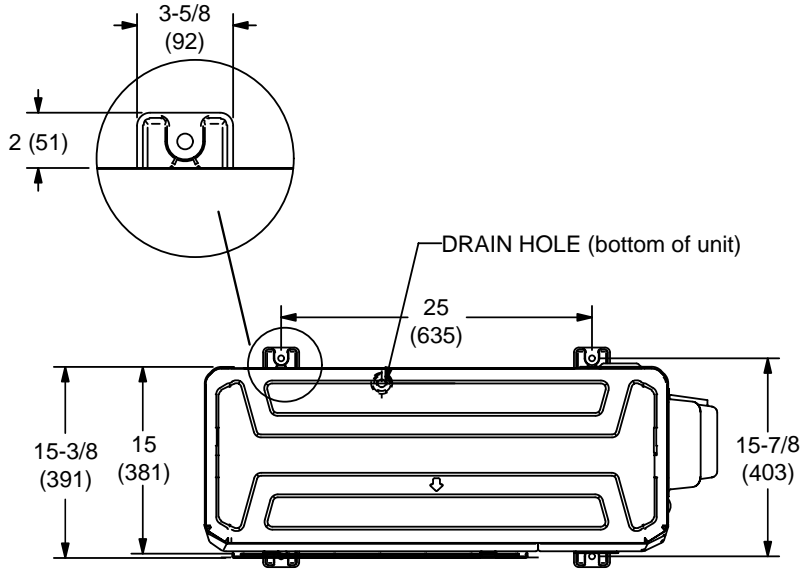

TOP VIEW

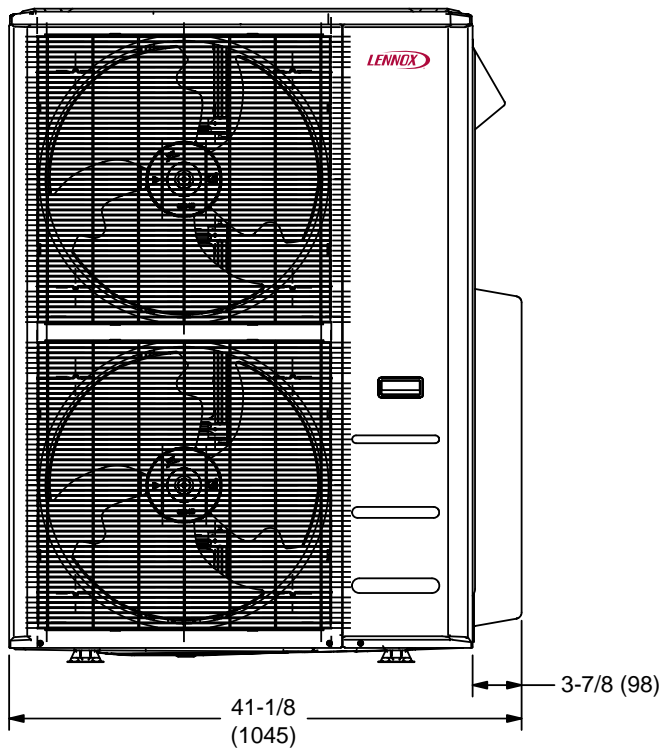

FRONT VIEW

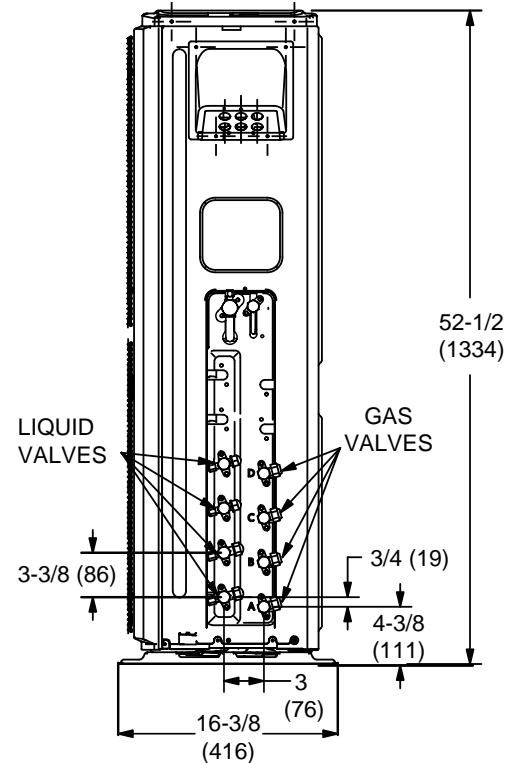

SIDE VIEW

NOTE - Due to Lennox' ongoing commitment to quality, Specifications, Ratings, and Dimensions are subject to change without notice and without incurring liability. Improper installation, adjustment, alteration, service or maintenance can cause property damage or personal injury. Installation and service must be performed by a qualified installer and servicing agency.