



**SUBMITTAL DATA – CEILING/FLOOR**  
**MLB018S4S-1P – MCFB018S4-1P**  
 SINGLE ZONE MINI-SPLIT HEAT PUMP

**Job:** \_\_\_\_\_  
**Location:** \_\_\_\_\_  
**Schedule No.:** \_\_\_\_\_  
**System Designation:** \_\_\_\_\_

**Engineer:** \_\_\_\_\_  
**Architect:** \_\_\_\_\_  
**Date:** \_\_\_\_\_  
**For:**  Reference  Approval  Review  Construction

**FEATURES**

**Outdoor Unit: MLB018S4S-1P**



- Low Ambient Heating/Cooling
- DC Inverter Control
- Compressor Overcurrent Protection
- Base Dancer
- Defrost Control

**Indoor Unit: MCFB018S4-1P**



- Pre Heat Function
- Auto Restart
- Three Selectable Fan Speeds
- Flare Connections
- LED Readout/Infrared Receiver Panel
- Wireless Remote Included

**PIPING**

**Line Set and Elevation Guidelines**

Maximum Line Set Length ft. (m)	98 ft. (30 m)
Maximum Elevation - Outdoor Unit Below/Above Indoor Unit ft. (m)	66 ft. (20m)
Liquid Line Set Diameter (in.)	1/4
Gas Line Set Diameter (in.)	1/2
Pre-Charged (ft.)	25 ft.
Additional Charge of Refrigerant (oz/ft.)	0.16

**PRODUCT WARRANTY**

Compressor – Twelve year limited warranty\*  
 All other covered components - Twelve year limited warranty\*  
 \*Product registration required

**OPTIONAL ACCESSORIES**

Non-Programmable Controller (M0STAT61Q-1)  
 Programmable Controller (M0STAT64Q-2)



NOTE – Due to Lennox' ongoing commitment to quality, Specifications, Ratings, and Dimensions are subject to change without notice and without incurring liability. Improper installation, adjustment, alteration, service or maintenance can cause property damage or personal injury. Installation and service must be performed by a qualified installer and servicing agency.



# SUBMITTAL DATA – CEILING/**FLOOR**

## ML**B018S4S-1P** – M**CFB018S4-1P**

### SINGLE ZONE MINI-SPLIT HEAT PUMP

#### OUTDOOR SPECIFICATIONS

##### PERFORMANCE

Cooling Capacity (Min/Max) (Btu/h) <sup>1</sup>	17,000 <del>17,000</del> <del>17,000</del> <del>17,000</del>
EER	12.5
SEER	20.2
Heating Capacity (Min/Max) (Btu/h) <sup>1</sup>	18,000 <del>18,000</del> <del>18,000</del> <del>18,000</del>
HSPF	10.5
Outdoor Fan Total Air Volume (CFM)	1,355
Ambient Temperature Operating Range	
Cooling	-22°F - 122°F
Heating	-22°F - 86°F

##### ELECTRICAL DATA

Power Supply (V/Hz/Φ)	208-230/60/1
Minimum Circuit Ampacity (A)	16
Maximum Overcurrent Protection (A)	25
Outdoor Fan Motor RLA (A)	0.76
No. of Compressors	1

##### GENERAL DATA

Connection Ratio (%)	100%
Max. # of Indoor Units	1 unit
Sound Data (dBA) - Cooling/Heating	59/59
Refrigerant type	R-410A
Factory refrigerant charge	4 lbs. 1 oz.

##### DIMENSIONS

Unit Dimensions (in)	Height	27-5/8
	Width	36
	Depth	14-3/4
Shipping Weight (lb)	108	
Net Weight (lb)	101	

##### NOTES

- Cooling and Heating Capacity data is rated at the following conditions:  
 Cooling: 80°FDB / 67°FWB Indoor, 95°FDB Outdoor  
 Heating: 70°FDB Indoor, 47°FDB / 43°FWB Outdoor

#### OUTDOOR DIMENSIONAL DRAWINGS - INCHES (MM)

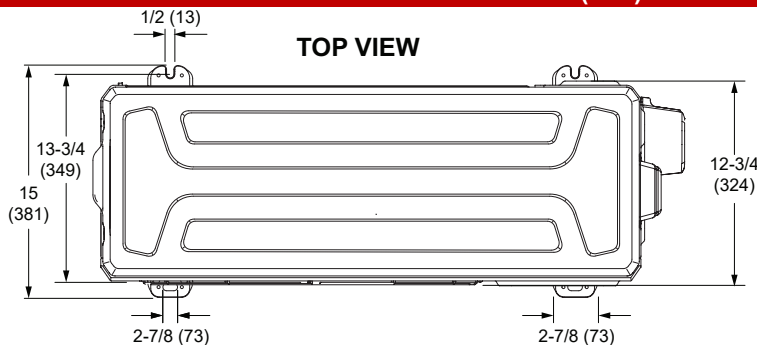

##### FRONT VIEW

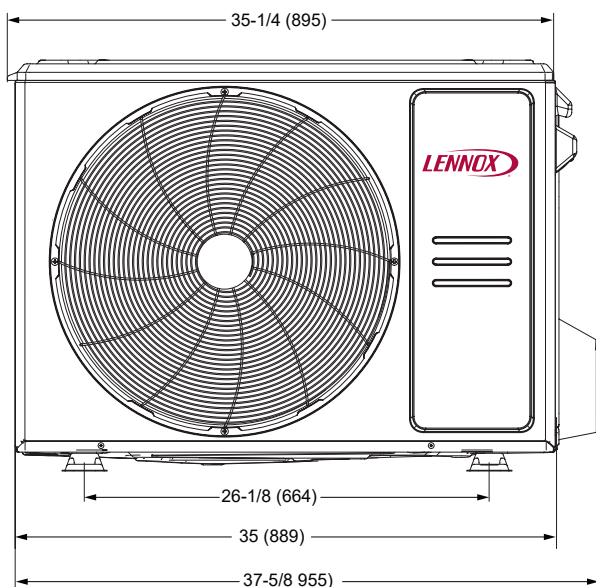

##### SIDE VIEW

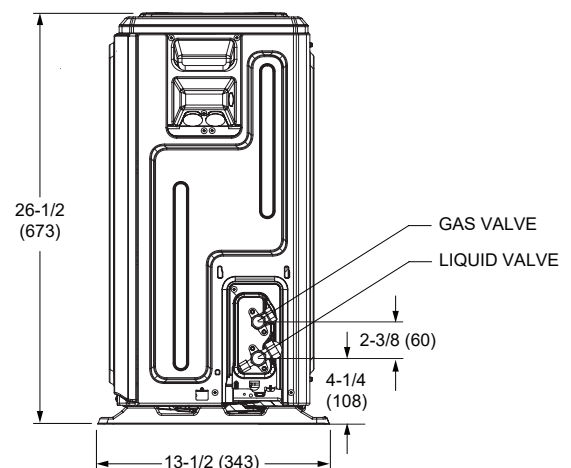

NOTE – Due to Lennox' ongoing commitment to quality, Specifications, Ratings, and Dimensions are subject to change without notice and without incurring liability. Improper installation, adjustment, alteration, service or maintenance can cause property damage or personal injury. Installation and service must be performed by a qualified installer and servicing agency.



# SUBMITTAL DATA – CEILING/FLOOR

## MLB018S4S-1P – MCFB018S4-1P

### SINGLE ZONE MINI-SPLIT HEAT PUMP

#### INDOOR SPECIFICATIONS

##### PERFORMANCE

Airflow (CFM)	High	580
	Medium	520
	Low	465
External Static Pressure (in. w.g.)		-
Sound Pressure (dBA)	High	46
	Medium	43
	Low	39

##### ELECTRICAL DATA

Power Supply (V/Hz/Φ)	Supplied by ODU
Rated load amps (RLA)	1.65
Power Output (W)	90

##### DIMENSIONS

Unit Dimensions (in)	Height	9-1/4
	Width	42
	Depth	26-5/8

Unit Net/Shipping Weight (lb)	58/69
-------------------------------	-------

##### PIPING

Liquid/Gas O.D. Flare (in.)	1/4 , 1/2
Drain Connection O.D. (in.)	1

#### INDOOR DIMENSIONAL DRAWINGS - INCHES (MM)

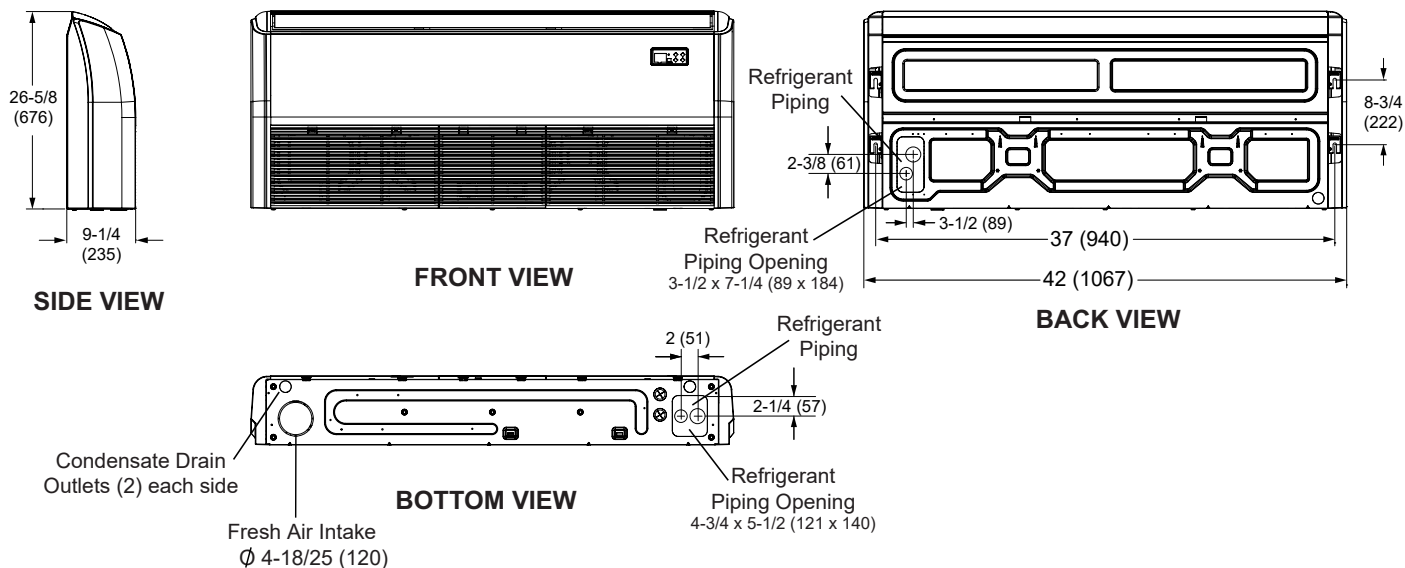

NOTE – Due to Lennox' ongoing commitment to quality, Specifications, Ratings, and Dimensions are subject to change without notice and without incurring liability. Improper installation, adjustment, alteration, service or maintenance can cause property damage or personal injury. Installation and service must be performed by a qualified installer and servicing agency.